

**IMMUNE FUNCTION AND STRUCTURAL ANALYSIS OF
RECOMBINANT BOVINE CONGLUTININ AND HUMAN
LUNG SURFACTANT PROTEIN-D**

**A thesis submitted in partial fulfilment of the requirement for the
degree of the Doctor of Philosophy**

TRINITY 2000

Alpana PRASAD

St. Hilda's College

MRC Immunochemistry Unit

Department of Biochemistry

University of Oxford

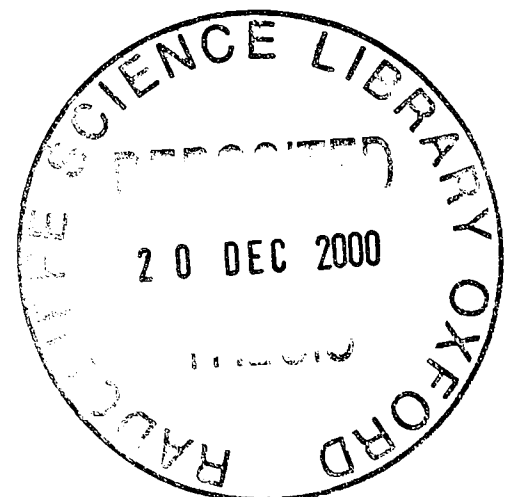

I would like to thank.....

My supervisor, Prof. Ken Reid, for his guidance and encouragement throughout the course of my study.

Felix Scholarship Trust, for awarding the Felix Scholarship, without which my D.Phil. at Oxford would not have been possible.

Radhakrishnan Trust and St. Hilda's college for the financial assistance.

Dr. S. Gulati (Boston, USA) and Dr S. Ram for the collaboration in the functional studies with Neisseria .

Dr. A. Dodds for his help with BIAcore studies, Dr. F. Poulain for Bacterial agglutination studies, Ms B. Moffat for her help with tissue culture, Dr. R. Jingshan (Churchill hospital) for his collaborative crystallisation studies and James for his help with cytospin.

To the members of F6 past and present especially Steve, Emma and Paul for very enjoyable tea sessions and making my D. Phil. a great learning experience.

To MRCICU members especially Tony W, Alison, Liz, Tan, Rob, and Andi for their help at various occasions.

Many thanks to all my friends for the good times and especially to Jayashree and Rachel for being there for me in rain or shine.

Above all, to my parents and sister for their endless support and motivation.

ABSTRACT

Alpana Prasad
St. Hilda's College

Submitted for the degree of D.Phil.
Trinity 2000

Recognition of sugar moieties on the surface of microorganisms is one of the ways the body distinguishes potential pathogens from self-cells. The sugar-binding proteins, lectins, mediate this recognition role of the first line of defence against infections, preceding the antibody-mediated (adaptive) immune response. Collectins are calcium-dependent carbohydrate-binding proteins that have been implicated in innate immunity. Bovine conglutinin (BC) and lung surfactant protein-D (SP-D), belong to the family of 'collectins' which are characterised by four domains: an N-terminal cysteine-rich region, a collagen-like region linked with the carbohydrate recognition domain (CRD) via an α -helical neck region. BC and SP-D show remarkable similarity in their amino acid sequence (79% identity), function and biological characteristics. They have been shown to mediate microbial clearance either by directly binding to bacteria leading to phagocytosis or interacting with complement system components.

The present study aims to elucidate the biological function of these proteins more precisely. Recombinant fragments (r) of BC and SP-D consisting of their CRDs and neck regions have been cloned in pET-21a and pMal-c2 vectors respectively, for expression in *Escherichia coli*. Recombinant conglutinin was expressed in BL21(DE3)pLysS and isolated by a denaturation-renaturing procedure. Binding of rBC(N/CRD) to mannan and complement component, iC3b, was assessed in real-time by BIAcore. The dissociation constants were calculated by Scatchard analysis.

The carbohydrate structures present on the surface of the microorganisms play an important role in mediating the interactions with the immune cells. The recombinant molecules showed calcium-dependent binding to lipopolysaccharides (LPS) from gram-negative bacteria *Pseudomonas aeruginosa*, *Klebsiella pneumoniae* and *Salmonella typhosa*, which was inhibited in presence of sugars. rBC(N/CRD) also bound to whole bacteria as assessed by ELISA and retained its capacity to recognise various complement system components and the carbohydrate moieties on the surface of various pathogenic microorganisms. The recombinant protein retained its ability to bind various sugar residues, although with lower affinity than that of the native molecule. rBC(N/CRD) is able to bind and aggregate bacteria and cause agglutination of bacterial cell suspensions.

A novel model has been used to describe the interactions of the collectins at the molecular level based on specificity of carbohydrate-recognition by the collectins. The pyocin mutant strain 1291 series of *Neisseria gonorrhoeae* has sequential deletions of the terminal sugars in their lipooligosaccharides (LOS). Conglutinin showed a preferential high affinity binding to 1291a mutant that expresses GlcNAc as the terminal hexose, in comparison to other mutants.

This provides a unique system to understand the specific cell-surface interactions in relevance to a particular lectin.

Further elucidation of the function of CRD and neck region at a structural level is in progress, using X-ray crystallography. Since the submission of the thesis, the structure of the monomeric CRD has been solved, which revealed a remarkable similarity to the SP-D and MBL structure. Trials are underway to get the structure of the trimeric CRDs

These studies aim to provide a better understanding of the collectin-pathogen interaction at the biological and structural levels. The ultimate aim is to determine if the recombinant forms of these proteins can be used therapeutically to enhance the uptake and killing of pathogens.

ABBREVIATIONS

Abs (A)	Absorbance
APCs	Antigen Presenting Cells
APS	Ammonium Persulphate
ATP	Adenosine Triphosphate
ATRA	All-trans retinoic acid
BC	Bovine Conglutinin
BIA	Biomolecular Interactions Analysis
bp	Base Pair
BSA	Bovine Serum Albumin
CD	Clusters of differentiation
cDNA	complementary DNA
CRD	Carbohydrate Recognition Domain
CTLD	C-type Lectin Domain
DMSO	Dimethyl Sulphoxide
DNA	Deoxyribonucleic acid
dNTPs	2'-deoxy Nucleotide Triphosphate
DTT	Dithiothreitol
EDTA	Ethylene Diamine tetra-acetic acid, disodium salt
ELISA	Enzyme-Linked Immunosorbent Assay
FACS	Fluorescence Activated Cell Sorting
FITC	Fluorescein-isothiocyanate
FPLC	Fast Protein Liquid Chromatography
Fuc	Fucose
Gal	Galactose
GC	Gonococci
Glc	Glucose
GlcNAc	N-acetyl Glucosamine
HIV	Human Immunodeficiency Virus

HPLC	High Performance Liquid Chromatography
IAV	Influenza-A virus
Ig	Immunoglobulin
IP3	Inositol Triphosphate
IPTG	Isopropyl thio- β -D Galatoside
kb	kilobase pair
kDa	kilo Dalton
LB	Luria-Bertani
LIC	Ligation-independent cloning
LOS	Lipooligosaccharide
LPS	Lipopolysaccharides
MASP	MBL-associated Serine Protease
MBL	Mannose-Binding Lectin
Mol. Wt.	Molecular weight
Mr	Relative Molecular Mass
mRNA	Messenger RNA
NHS	Normal human Serum
OD	Optical Density
PAGE	Polyacrylamide Gel Electrophoresis
PBS	Phosphate-Buffered Saline
PBS/+	Dulbecco's Phosphate Buffered saline with calcium and magnesium
PBS/O	Dulbecco's Phosphate Buffered saline without divalent cations
PCR	Polymerase chain reaction
PEG	Polyethylene Glycol
pI	Isoelectric point
PMA	Phorbol Myristate Acetate
PMN	Polymorphonuclear cells
rBC(Δ coll)	recombinant BC with collagen region deletion
rBC(N/CRD)	recombinant BC comprising of Neck and CRD

	regions
RNA	Ribonucleic acid
rpm	Revolution per Minute
rSP-D(N/CRD)	recombinant SP-D comprising of Neck and CRD regions
RT	Room Temperature
RU	Resonance Units
SDS	Sodium Dodecyl Sulphate
SP-A	Surfactant Protein-A
SP-D	Surfactant Protein-D
SPR	Surface Plasmon Resonance
TBS	Tris-buffered saline
TEMED	N,N,N',N'-Tetra Methylene Diamine
T _m	Melting Temperature
Tris	tris (hydroxymethyl)-aminomethane
UTR	Untranslated Terminal Repeats
UV	Ultraviolet
v/v	Volume per Volume
w/v	Weight per Volume
β-ME	β-Mercaptoethanol

The single letter and triplet codes for the amino acid residues are used. Other abbreviations are defined in the text where first encountered.

CHAPTER - 1

CONTENTS

Abstract

Abbreviations

1	INTRODUCTION.....	1
1.1	<i>Historical Background</i>	<i>1</i>
1.2	<i>Lectins</i>	<i>2</i>
1.2.1	Plant Lectins.....	3
1.2.2	Animal Lectins	4
1.3	<i>Classification Of Animal Lectins</i>	<i>6</i>
1.3.1	P-type Lectins.....	8
1.3.2	C-type Lectins	8
1.3.3	I-type Lectins	9
1.3.4	S-type Lectins (Galectins)	9
1.3.5	Ficolins	11
1.3.6	Pentraxins	14
1.3.7	Others	15
1.4	<i>C-Type Lectins</i>	<i>16</i>
1.4.1	Proteoglycans.....	18
1.4.2	Type II Transmembrane Receptors	18
1.4.3	Collectins	20
1.4.4	Selectins.....	21
1.4.5	Lymphocyte Type-II Antigen.....	23
1.4.6	Multi CRDs Receptors	23
1.4.7	Miscellaneous C-type CRDs.....	25
1.4.8	C-type Lectin Domain Fold	26
1.5	<i>Collectins.....</i>	<i>27</i>

1.5.1	Polypeptide Structure	28
1.5.1.1	N-terminal Domain.....	29
1.5.1.2	Collagen-like Domain.....	31
1.5.1.3	Neck Region.....	31
1.5.1.4	Carbohydrate Recognition Domain.....	32
1.5.2	Interaction with Complement System	34
1.6	<i>Mannan-Binding Lectin</i>	38
1.6.1	Structure.....	39
1.6.2	Properties	41
1.7	<i>Bovine Conglutinin</i>	42
1.7.1	Biosynthesis & secretion	42
1.7.2	Properties	43
1.7.3	Structure.....	45
1.7.4	Overall structure.....	47
1.7.5	Interaction with sugars	48
1.7.6	Interaction with Complement System Components.....	48
1.7.7	Interactions with Microorganisms.....	49
1.8	<i>Collectin-43</i>	49
1.9	<i>CL-L1</i>	51
1.10	<i>Pulmonary System Overview</i>	52
1.10.1	Immunologic Components of the Airways	53
1.10.2	Components of the Surfactant.....	56
1.10.2.1	Lipids	56
1.10.2.2	Surfactant apoproteins	57
1.10.3	Surfactant metabolism	58
1.11	<i>Surfactant Protein-A</i>	60
1.11.1	Tissue distribution.....	61

1.11.2	Structure.....	61
1.11.3	Properties	63
1.11.4	Physiological roles (surfactant).....	63
1.11.5	Physiological roles (collectin).....	64
1.11.6	SP-A null mouse model	67
1.12	<i>Surfactant Protein-B</i>	68
1.13	<i>Surfactant protein-C</i>	70
1.14	<i>Surfactant Protein-D</i>	71
1.14.1	Biosynthesis and Distribution	72
1.14.2	Structure.....	73
1.14.3	Crystal Structure of the Trimeric CRD.....	74
1.14.4	Functional Properties	76
1.14.5	Interactions with Microorganisms.....	76
1.14.6	Interactions with Immune Cells	79
1.14.7	SP-D null Mouse Model	80
1.15	<i>Collectin Receptors</i>	81
1.16	<i>Genomic Organisation</i>	83
1.17	<i>Evolutionary Relationship</i>	85
2	MATERIALS AND METHODS	87
2.1	<i>Biochemicals</i>	87
2.2	<i>Bacterial Strains</i>	87
2.3	<i>Vectors</i>	87
2.4	<i>Molecular Biology Reagents</i>	87
2.5	<i>Immunological Reagents</i>	88
2.6	<i>Crystallisation Reagents</i>	88
2.7	<i>Methodologies</i>	88
2.8	<i>Molecular Biology Techniques</i>	89

2.8.1	Storage of Bacterial Cells	89
2.8.2	DNA Extraction and Purification	89
2.8.3	DNA Separation by Agarose Gel Electrophoresis	90
2.8.4	DNA Purification by Agarose Gel Electrophoresis.....	90
2.8.5	DNA Sequencing.....	91
2.8.6	Preparation of Competent Cells	91
2.8.6.1	Calcium Chloride Method.....	91
2.8.6.2	Rubidium Chloride Method	92
2.8.7	Transformation of Competent E. coli Cells.....	92
2.8.8	Transformation of Commercial Competent Cells.....	93
2.8.9	PROTEIN EXPRESSION SYSTEMS	94
2.8.9.1	pET Expression System	94
2.8.9.1.1	pET-12a.....	95
2.8.9.1.2	pET-21a.....	96
2.8.9.1.3	pET-32a Xa/LIC	96
2.8.9.2	MBP Fusion System.....	97
2.9	<i>Protein Chemistry Techniques</i>	98
2.9.1	Polyacrylamide Gel Electrophoresis	98
2.9.2	Estimation of Protein Concentration (BioRad).....	99
2.9.3	High Performance Liquid Chromatography (HPLC)	100
2.9.4	N-terminal Sequencing.....	100
2.9.5	Mass Spectrometer	101
2.10	<i>BIAanalysis</i>	101
2.10.1	Principle.....	101
2.10.2	Sensor Surface.....	103
2.10.3	Ligand Immobilisation	104
2.10.3.1	Amine Coupling Using Reactive Esters.	104

2.10.3.2	Coupling by Thiol-disulphide Exchange.	105
2.10.3.2.1	Ligand-Thiol Procedure.....	105
2.10.3.2.2	Surface-Thiol Procedure.....	106
2.10.3.3	Binding Biotinylated Ligands to Immobilised Streptavidin. ...	106
2.10.3.4	Aldehyde Coupling to a Hydrazine-activated surface.	106
2.10.4	SPR in Real-time BIA.....	106
2.10.4.1	Basic Kinetic Measurement.....	108
2.10.4.2	Competitive Kinetics.....	109
2.10.5	Methodology.....	110
2.10.5.1	Reagents.....	110
2.10.5.2	Immobilisation of iC3b.....	110
2.10.5.2.1	Activation.....	110
2.10.5.2.2	Ligand Immobilisation.....	111
2.10.5.2.3	Deactivation.....	111
2.10.5.3	Immobilisation of Biotinylated Mannan.....	111
3	RECOMBINANT BOVINE CONGLUTININ.....	112
3.1	<i>Introduction.....</i>	<i>112</i>
3.2	<i>Expression in bl21(de3).....</i>	<i>112</i>
3.3	<i>Expression and Purification.....</i>	<i>114</i>
3.3.1	Methods.....	114
3.3.1.1	Protein Expression.....	114
3.3.1.2	Protein Extraction.....	115
3.3.1.3	Protein Purification.....	116
3.3.1.3.1	Affinity Purification.....	116
3.3.1.3.2	Ion-exchange Purification.....	117
3.3.1.3.3	Gel-Filtration Chromatography.....	117
3.3.2	Results.....	118

3.3.2.1	Expression.....	118
3.3.2.2	Purification.....	120
3.4	<i>Biochemical Characterisation</i>	123
3.4.1	Molecular Size	123
3.4.2	HPLC.....	124
3.4.3	Mass Spectrometry	125
3.4.4	N-terminal Sequencing	127
3.5	<i>Functional Characterisation</i>	127
3.5.1	BIAanalysis of the Gel-filtration Fractions.	127
3.5.2	Solid Phase Carbohydrate Binding Assay	127
3.5.3	Biotinylation	128
3.5.4	Results	129
3.5.4.1	BIAanalysis.....	129
3.5.4.2	Carbohydrate Binding Assay.....	130
3.5.4.3	Biotinylation.....	132
3.5.5	BIAanalysis of Interaction.....	134
3.5.5.1	Methodology	134
3.5.5.2	Procedure summary:.....	134
3.5.5.3	BIAanalysis.....	135
3.5.5.3.1	Binding to Mannan	135
3.5.5.3.2	Binding to iC3b	135
3.6	<i>Binding to Lipopolysaccharides</i>	138
3.6.1	Method.....	138
3.6.2	Results	139
3.7	<i>Crystallisation Studies</i>	140
3.7.1	Crystallisation Trials of rBC.....	141
3.8	<i>Summary</i>	143

3.9	<i>Discussion</i>	145
4	INTERACTIONS WITH BACTERIA	148
4.1	<i>Materials</i>	148
4.1.1	Complete Media.....	148
4.1.2	Buffers	148
4.1.3	Bacterial Strains	148
4.1.4	Human Cell Line	149
4.1.5	Antibodies.....	149
4.2	<i>Bacterial Aggregation Studies</i>	149
4.2.1	Cell Culture.....	149
4.2.2	Agglutination Assay	150
4.2.3	Bacterial Agglutination Studies	151
4.3	<i>Direct Binding To Bacteria</i>	155
4.3.1	Method.....	155
4.3.2	Results	156
4.4	<i>HL60 Cell Culture</i>	157
4.4.1	Induction of Differentiation	158
4.4.2	FACS Analysis.....	158
4.4.3	Results	159
4.5	<i>Phagocytosis</i>	162
4.5.1	Cytospin.....	162
4.6	<i>Summary</i>	163
4.7	<i>Discussion</i>	164
5	INTERACTIONS WITH NEISSERIA	166
5.1	<i>Introduction</i>	166
5.2	<i>Pathogenesis</i>	166
5.3	<i>Cell Wall</i>	168

5.4	<i>Surface Antigens</i>	168
5.4.1	TypeIV pili.....	168
5.4.2	Opa Proteins.....	170
5.4.3	Porins.....	171
5.4.4	Lipooligoosaccharide	172
5.4.5	Other Components.....	175
5.5	<i>Immune Responses</i>	175
5.5.1	Interaction with Complement	175
5.5.2	Interaction with Phagocytes.....	177
5.5.3	Humoral Response	178
5.6	<i>Serum Resistance</i>	178
5.7	<i>Lipooligosaccharides</i>	179
5.7.1	Structure.....	179
5.7.2	Pyocin Resistance.....	182
5.7.3	Biosynthesis	183
5.7.4	Role in Pathogenesis.....	184
5.8	<i>Interaction With Lectins</i>	186
5.9	<i>Materials And Methods</i>	187
5.9.1	Strains	188
5.9.2	Shipping the Strains	188
5.9.3	Culturing the Bacteria.....	188
5.9.4	Preparation of the LOS	189
5.10	<i>Binding to LipoOligoSaccharides</i>	191
5.10.1	Results	191
5.11	<i>Binding to Whole Bacterial Cell</i>	192
5.11.1	Method.....	192
5.11.2	Results	193

5.12	<i>Summary</i>	194
5.13	<i>Discussion</i>	195
6	CONGLUTININ WITH COLLAGEN REGION DELETION.....	196
6.1	<i>Introduction</i>	196
6.2	<i>Pilot Expression Study</i>	196
6.2.1	Cell Culture.....	196
6.2.2	Protein Purification.....	197
6.3	<i>Results</i>	197
6.4	<i>Cloning Into pET-32a LIC/Xa</i>	198
6.4.1	Primers.....	198
6.4.2	Polymerase Chain Reaction Protocol.....	199
6.4.3	T4 DNA Polymerase Treatment.....	200
6.4.4	Annealing.....	201
6.4.5	Transformation.....	201
6.4.6	Results.....	201
6.5	<i>Summary</i>	202
6.6	<i>Discussion</i>	203
7	LUNG SURFACTANT PROTEIN-D.....	205
7.1	<i>Introduction</i>	205
7.2	<i>Pilot Expression</i>	205
7.2.1	Small-scale Culture.....	205
7.2.2	Protein Purification.....	206
7.3	<i>Results</i>	206
7.4	<i>DNA Sequencing</i>	208
7.5	<i>Cloning Into pET-32a LIC/Xa</i>	208
7.5.1	Primers.....	208
7.5.2	Polymerase Chain Reaction Protocol.....	209

7.5.3	T4 DNA Polymerase Treatment.....	210
7.5.4	Annealing.....	211
7.5.5	Transformation.....	211
7.5.6	Results	211
7.6	<i>Summary</i>	212
7.7	<i>Discussion</i>	213
8	GENERAL DISCUSSION.....	215
	TABLE OF FIGURES	221
	TABLE OF TABLES	225
	REFERENCES.....	226
	Appendices	i

1 INTRODUCTION

1.1 HISTORICAL BACKGROUND

In 1888 Herman Stillmark discovered a haemagglutinin (that he called ricin) in the extracts of castor beans, which agglutinated a suspension of red blood cells of different animal species. These experiments were extended by Ehrlich in 1891, who provided the evidence for the immunological specificity of the lectins by showing that an antiserum raised against one particular lectin abrogated the agglutination mediated by that lectin and not that mediated by any other (reviewed in *Boyd, 1970*).

Although lectins were discovered a century ago, the term only came into use in 1954 when Boyd coined it (from the Latin *legere*, meaning to choose), to emphasise the new finding that lectins could selectively bind complex glycoconjugates. He demonstrated that different plant agglutinins specifically agglutinated erythrocytes from the blood of type A or O (*Boyd and Shapleigh, 1954*), thereby defining the lectins as ‘the plant agglutinins which specifically agglutinated erythrocytes from blood group A or O’. The meaning of the term has been changing ever since. With the discovery of new carbohydrate binding proteins which neither agglutinated red cells nor were of plant-origin, Sharon and Lis proposed a broader definition ‘all sugar-binding proteins of non-immune origin, whether blood group-specific or not’ (*Sharon and Lis, 1972*).

For historical reasons, the present definition requires that the lectins agglutinate cells or precipitate glycoconjugates, implying that they must contain at least two sugar-binding sites (*Barondes, 1988*). This definition had to be revised

with increasing structural and functional examination of lectins, which could be monovalent e.g. chicken intestine lectin (*Beyer et al.*, 1980) or multivalent e.g. collectins. The identification of bifunctional lectins *i.e.* exhibiting biologically significant lectin-carbohydrate and lectin-protein interactions, *viz.* Elastin receptor and the protein of immune origin, membrane-bound macrophage mannose receptor, which mediates phagocytosis by interacting with the microorganisms presenting terminal mannose or fucose residues, are both in contradiction to the prevailing definition. Thus a less-restrictive definition has been proposed: ‘a carbohydrate-binding protein other than an enzyme or an antibody.’ Even though this concept is so inclusive, Barondes highlights the advantage of the broadened definition as this would also help focus attention on the evolution of lectins and on their adaptation for a variety of functions in biological systems (*Barondes*, 1988).

1.2 LECTINS

Lectins have the capability to serve as recognition molecules, binding specifically and reversibly to carbohydrates. For nearly 100 years lectin research has been focussed on proteins from plants. These non-enzymatic, sugar-binding proteins have been invaluable tools in the structural and functional analysis of animal cell glycoconjugates because of their ability to discriminate among the myriad of complex carbohydrate structures that are found on the surface of cells, in extracellular matrix and attached to soluble glycoproteins. These proteins have been isolated from all classes of living organisms including fungi, lichens as well as animals. The major classes of lectin: plant and animal lectins are described in the following sections.

1.2.1 PLANT LECTINS

Plant lectins^a have been attracting much attention because of their ease of isolation and their usefulness as reagents for glycoconjugates in solution and on cell surface. These proteins seem to play an important role in the defence mechanisms of the plants against attack of microorganisms, pests and predators (*Peumans and van Damme, 1995*). Fungal infection or wounding of the plant seems to increase lectin levels (*Mishkind et al., 1982*). Other roles in plants may involve cell wall extension (*Horisberger et al., 1978*), mitogenic stimulation, transport of carbohydrates, storage of proteins, packaging and/or mobilisation of storage material (*Voelker et al., 1989*). Lectins have been isolated from the bulbs, tubers, rhizomes and corms of many plant families. The largest family of plant lectins are those obtained from the seeds of the legumes. They may exist in various tissues of the same plant and have different cellular localisation and molecular properties.

One of the major interests in this class of glycoproteins is their anti-retroviral property and their role in cancer therapy. Jacalin, extracted from Jackfruit (*Maculera pomifera*), is found to completely block human immunodeficiency virus type-1 infection of lymphoid cells (*Blasco et al., 1995*) *in vitro*. This is attributed to its ability to specifically induce the proliferation of CD4+ T lymphocytes in humans. The agglutinins, VAA-I and II, isolated from mistletoe (*Viscum album*) have been used as adjuvants in chemotherapy (*Kubasova et al., 1999*). VFA the

Vicia fava lectin, has been shown to slow the progression of colon cancer (Jordinson *et al.*, 1999).

1.2.2 ANIMAL LECTINS

Animal lectins mediate a myriad of biological processes from protein folding and trafficking to the modulation of cell-cell and cell-matrix interactions. Given that the monosaccharide-binding specificity of a lectin is an important determinant of its function, many animal lectins are found to recognise those monosaccharides – recently called ‘terminal elaborations’ (e.g. sialic acid, galactose and sulphated sugars) – that are characteristics of multicellular organisms (Drickamer and Taylor, 1998).

The description of the asialoglycoprotein receptor in mammalian liver provided the first model of how an animal lectin might discriminate between various glycoproteins (Kolb-Bachofen, 1981). In the ensuing years, a large number of animal lectins have been isolated and their biological roles elaborated. These proteins have the ability to recognise carbohydrates either endogenous to animals or those presented to them by the pathogens, leading to increased emphasis on their therapeutic potential.

Animal lectins do not express a recombinatorial diversity like that of antibodies. Thereby a limited diversity in recognition capabilities has to be accomplished by the occurrence of multiple lectins with distinct specificities. The

^a Plant lectins also belong to the class of plant toxins. Some of the dietary plant lectins have been implicated in adverse effects on animals, ranging from highly toxic Abrin to moderately toxic Concanavalin A (fatal only if ingested in high amounts).

presence of more than one binding site specific for different carbohydrates in a single molecule, and by certain ‘flexibility’ of the binding sites is considered to allow the recognition of a range of structurally related carbohydrates, which decorate the surface of microorganisms.

Almost all microorganisms express surface-exposed carbohydrates. The carbohydrates may be covalently bound, as in glycosylated teichoic acids to peptidoglycan, or non-covalently-bound, as in capsular polysaccharides. Every surface-exposed carbohydrate is a potential lectin-reactive site. Microbial receptors for lectins consist of several unique chemical structures, summarised in Table 1-1. The basic pre-requisite for interaction between most lectins and glycoconjugates of the microbial surface is that the receptor sites contain non-reducing sugar residues.

Table 1-1: Examples of the potential lectin-reactive site on the surface of various microorganisms.

Fungi	Arabinans, capsules, cell wall glucan, chitin, galactans, mannans, secreted proteins
Gram-negative bacteria	Capsules, cytoplasmic membranes, lipopolysaccharides, lipooligosaccharides, outer membranes, peptidoglycan, surface array glycoproteins
Gram-positive bacteria	Capsules, group-specific polysaccharides, lipoteichoic acids peptidoglycans, surface arrays, teichoic acids, teichuronic acids
Protozoa	Galactomannose, glycoproteins, glycolipids, lipophosphoglycans, phosphoglycans

While the infecting organism uses lectins to bind selected cell types, the host can deploy the use of lectins that bind the carbohydrate of the microorganisms. Mannose binding Lectin (MBL) and other opsonins have been implicated in innate

immunity through their opsonic activity. Opsonisation of microorganisms in this way by mammalian lectins has been termed as 'Lectinophagocytosis'.

There are numerous factors which dictate how a lectin and a microorganism may interact. These include all the factors that combine to make any protein retain its fidelity, such as proper pH and ionic conditions, proper temperature and presence of metal ions. Many lectins (plant, bacterial, invertebrate, vertebrate) require transition metals and/or Ca^{2+} or Mg^{2+} for activity. Factors such as receptor density, time, lectin mol. wt. and presence of hydrophobic sites near the saccharide receptor influence the specificity and the rate of interaction between lectins and receptors on microbial surface.

1.3 CLASSIFICATION OF ANIMAL LECTINS

Animal lectins comprise of a large and structurally diverse group of carbohydrate binding proteins. These lectins have been grouped based on the similarities in their primary structures. The carbohydrate-binding activity has been attributed to a specific region of the lectin, the carbohydrate-recognition domain (CRDs). Comparison of the sequences of these CRDs reveal that they fall into relatively few groups (*Drickamer, 1988*). These include C-type, S-type, I-type, P-type and Pentraxins. The relationship between these shared properties and the sequence similarities in each group are summarised in Table 1-2.

Table 1-2: Animal lectins and families (adapted from (Powell and Varki, 1995))

Lectin group	Number of known members	Defining features in protein sequence	Cofactor dependence	Carbohydrate recognition
C-type	>20	C-type lectin motif	Ca ⁺² (most)	Variable
S-type (Galectins)	8	S-type motif	Thiol (most)	β-galactoside
P-type (M6PRs)	2	Unique repeating motif	Ca ⁺² (variable)	Mannose-6-P, Insulin-like growth factor
I-type	>5	Immunoglobulin like domain	No	Sialic acid and other?
Pentraxins	>5	Multimeric binding motif	Ca ⁺² (most)	Variable
Calnexin and Calreticulin	2	Sequence homology to each other	Ca ⁺²	Glucosylated oligosaccharides
S4GGnM receptor	?1	Unknown	No	4-O-sulphated GalNAc
Hyaluron-binding protein e.g. CD44	5	Sequence homology among some	No	Hyaluron
Heparin-binding proteins	20	Basic amino acid clusters (variable)	No	Heparin and heparan sulphate
Ganglioside-binding proteins	NK [§]	NK	No	Sialylated glycolipids
Sulphoglucuronosyl lipid-binding protein	NK	NK	Yes	Sulphoglucuronosyl glycolipids

[§] NK- not known

CRDs in each group share a pattern of invariant and highly conserved amino acid residues at a characteristic spacing. CRDs in several of the major lectin groups share properties beyond similarity of primary structure. The C-type CRDs derive their name from the fact that they require calcium ions for activity. In addition, they all are extracellular and bind a diversity of sugars. In contrast, although the S-type lectins are found both inside and outside cells, they are often dependent on reducing agents (thiols) for full activity. They display no requirement of divalent cations, and they all bind β-galactosides. P-type CRDs bind mannose-6-

phosphate as their primary ligand, some of which are cation dependent. These families of animal lectins are discussed in the following sections.

1.3.1 P-TYPE LECTINS

This family of lectins include Mannose 6-Phosphate receptors, which play a role in the intracellular targeting of lysosomal enzymes (*Kornfeld, 1992*). Two distinct mannose 6-phosphate (M6P) receptors have been identified. One is a cation-independent type-I integral membrane glycoprotein with a mass of 275-300 kDa, which also binds insulin-like growth factor-II (IGF-II) (*Roberts et al., 1998*), and the other is a type-I integral membrane glycoprotein with a mass of 46-kDa, called the cation-dependent mannose 6-phosphate receptor (CD-MPR). The M6P/IGF-II receptor binds 2 molecules of M6P residues per polypeptide, whereas the CD-M6P receptor binds 1 molecule of M6P (*Dahms and Kornfeld, 1989; Tong et al., 1989; Tong and Kornfeld, 1989; Kornfeld, 1992*). The M6P/IGF-II receptor also binds retinoic acid (*Kang et al., 1997*) with high affinity at a site distinct from those for binding of M6P and IGF-II, and enhances the internalisation of exogenous β -glucuronidase (*Gabel and Foster, 1986*) and IGF-II. The cytoplasmic domains of these receptors contain numerous signals, viz. basolateral trafficking signals (*Distel et al., 1998*), phosphorylation sites, and palmitoylation sites (*Schweizer et al., 1996*) (*York et al., 1999*).

1.3.2 C-TYPE LECTINS

C-type lectins represent an important recognition mechanism for oligosaccharides at cell surfaces, attached to circulating proteins and in the extracellular matrix. Binding of specific sugar structures by these lectins mediates biological events,

such as cell-cell adhesion, serum glycoproteins turnover and innate immune responses to microorganisms and potential pathogens (*Drickamer and Taylor, 1993*). This family of lectins is discussed in details later in section 1.4.

1.3.3 I-TYPE LECTINS

A major new category of animal lectins involved in cell-cell interactions has recently been identified, containing extended arrays of 5-17 Ig-like repeats, hence the name Immunoglobulin type (I-type) lectins. The I-type lectin family includes the proteins sialoadhesin, CD22, CD33, myelin-associated glycoproteins (MAGs), Schwann cell myelin protein, and siglec-5 (*Cornish et al., 1998*), each of which is localised to a specific cell type (*Powell and Varki, 1994*) (*Kelm et al., 1994*). Sialoadhesin (or siglec-1) is found on macrophages (*Crocker et al., 1994*) and a role in lymphocyte adhesion and myeloid cell development has been proposed (*Kelm et al., 1996*).

These proteins are defined by their sialic-acid-binding specificity, a specific N-terminal V-set immunoglobulin domain that contains the carbohydrate binding site and a variable number of C2-set immunoglobulin domains (*Crocker et al., 1998*). All are integral membrane proteins, preferentially expressed on the plasma membrane, and some (CD33, CD22 and MAG) have large cytosolic domains with multiple potential and established phosphorylation sites (both Ser/Thr and Tyr) (*Powell and Varki, 1995*).

1.3.4 S-TYPE LECTINS (GALECTINS)

The galectins are members of a family of β -galactoside-binding lectins with related amino acid sequences, also referred to as S-type or S-Lac lectins, and

more recently called as 'Galectins'. The galectins are found in tissues of many animals, ranging from lower invertebrates such as sponges and nematodes to mammals including humans (*Hirabayashi and Kasai, 1993; Oda et al., 1993*). In mammals, four members of this family have been sequenced and characterised (Figure 1-1), and there is compelling evidence for the existence of other relatives. Individual mammalian galectins, Galectin-1, -2, -3 and -4, have been well characterised. Galectin-1 and -2 are homodimers composed of subunits of approximately 130 amino acids, each subunit folding as one compact globular domain. Galectin-3 and -4 include one or two such domains as well as others. The shared domain has been referred to as the carbohydrate-binding domain.

The galectins proteins have been implicated in growth regulation, cell adhesion, and cell migration and they are involved in neoplasia and immune responses. Galectin-3 has been suggested to be involved in enhancing or regulating the inflammatory response by interacting with primed neutrophils (*Karlsson et al., 1998*). All known members of this family lack a signal peptide, are found in the cytosol, and are isolated as soluble proteins. However, there is evidence that some members are externalised to the cell surface and extracellular matrix by an atypical secretory mechanism.

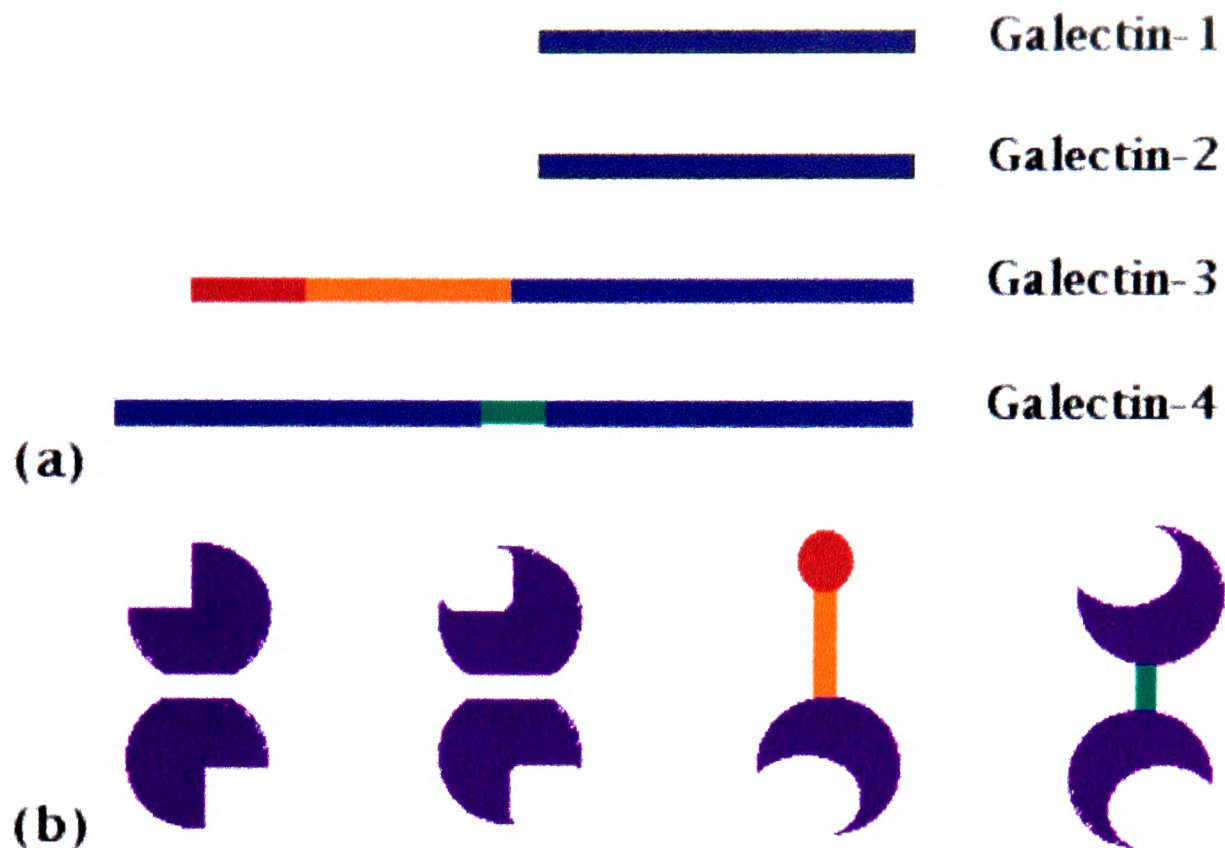

Figure 1-1: Schematic representation of the overall structures of galectins. The proteins galectin-1, -2, -3 and -4 are shown as linear diagrams corresponding to (a) single peptide chains and (b) as assembled proteins. The carbohydrate-binding domains (blue) of about 130 amino acids, the proline-, glycine-, and tyrosine-rich repeating domain (100 residues) of galectin-3 is shown in orange and the link peptide of galectin-4 (about 30 residues) is shown as green. The N-terminal region (brown) of galectin-3 is about 30 residues long. (*Barondes et al., 1994*)

1.3.5 FICOLINS

Ficolins are a group of plasma proteins containing collagen-like and fibrinogen-like (FBG) sequences and have a similar overall structure to that seen in C1q and the collectins (*Lu and Le, 1998*). There are two types of human ficolins: L-ficolin and M-ficolin. L-ficolin is synthesised in the liver and secreted into the plasma. It binds to several apparently unrelated structures including sugar residues and enhances phagocytosis of bound bacteria (*Le et al., 1998*). M-ficolin is synthesised mainly in monocytes and is detected on the monocyte surface (*Lu et al., 1996*).

The polypeptide sequences of ficolins, the collectins and C1q diverge mainly in their C-terminal globular regions which are, respectively, FBG domains, Ca²⁺-dependent carbohydrate recognition domains (C-type CRD), and collagen-related sequences (Figure 1-2). The FBG domain consists of 220-250 residues and is found in a number of proteins besides fibrinogen and ficolins. The ficolin polypeptide has a collagen-like domain that presumably brings three subunits together in a triple helical rod, a C-terminal fibrinogen-like domain (FBG) similar to that of tenascin, which presumably has the binding activities, and a small N-terminal domain that is the primary site for forming the ficolin oligomer.

Ficolins show affinity for carbohydrates, elastin, and corticosteroids. It has been recently shown that ficolin P35 activates the complement by association with MBL-associated serine proteases (MASP) MASP-1 and MASP-2 and its truncated form, small MBL-associated protein (sMAP, also called MAP19) (*Matsushita et al.*, 2000). The ficolin P35-MASPs- sMAP complex that was bound to *Salmonella typhimurium* was able to activate complement. These findings indicate that ficolin P35 is a second collagenous lectin capable of activating the lectin pathway and thus plays a role in innate immunity.

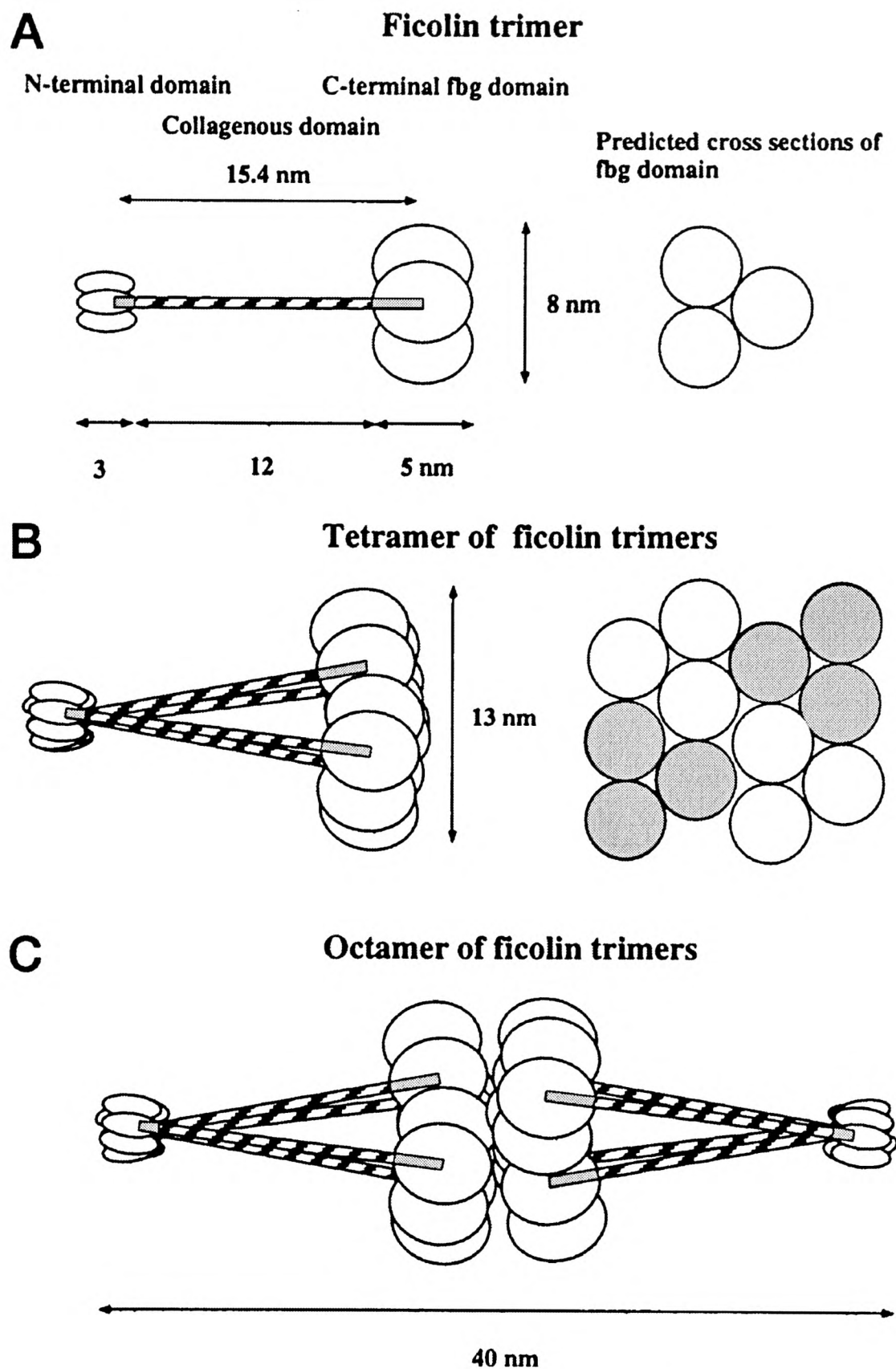

Figure 1-2: Schematic representation of the structural organisation of ficolins. (A) The trimeric ficolin unit consists of a short N-terminal domain, the middle collagenous domain, which forms an extended triple helical rod and the three C-terminal fibrinogen (fbg)-like globular domains. The subunits of this trimer may be linked by disulphide bridges near the fbg domains. (B) Little ficolin is a tetramer of trimeric subunits assembled at the N-terminal domains with additional disulphide linkages. The fbg domains must be densely packed within the central cluster to fit the ~13 nm width as observed in EM negative stain. The diagram at the right illustrates a possibility for a close packing of ~4 nm globular fbg domains. (C) Big ficolin is formed by the face to face fusion of the fbg clusters of the two little ficolins (*Ohashi and Erickson, 1997*).

1.3.6 PENTRAXINS

The pentraxins are a conserved family of vertebrate plasma proteins composed of protomers, each of about 200 residues arranged with cyclic pentameric symmetry (*Osmand et al.*, 1977) in a disc-like configuration. A homologous molecule exists in the haemolymph of the arachnid *Limulus polyphenus* (the horseshoe crab), although this contains 12 subunits in hexameric assembly (*Tennent et al.*, 1993). The human pentraxins are C-reactive protein (CRP), the classical acute phase reactant; and serum amyloid P component (SAP) (*Pepys and Baltz*, 1983). SAP is major DNA- and chromatin-binding protein of the plasma (*Pepys and Butler*, 1987) and the universal component of the abnormal tissue deposits which characterise the amyloid disease. Human CRP and SAP are each encoded by single genes located on chromosome 1 (*Floyd-Smith et al.*, 1986) and are secreted exclusively by liver.

All pentraxins are capable of calcium-dependant ligand binding and these reactions are functionally significant and phylogenetically their most conserved property (*Tennent and Pepys*, 1994). Human CRP binds most specifically to phosphocholine residues (*Schwalbe et al.*, 1992) and weakly to some carbohydrates including agar and galactans. Human SAP does not bind phosphocholine but recognises phosphoethanolamine as well as agarose, some galactosyl galactosides, zymosan, phosphomannans and sulphated glycosaminoglycans (reviewed in (*Tennent and Pepys*, 1994)).

Recently, several distinct larger proteins have been identified in which only the C-terminal halves show characteristic features of the pentraxin family.

One of the recently described 'long' pentraxins (TSG-14/PTX3) is inducible by TNF or IL-1 and is produced during the acute phase response (*Goodman et al.*, 1996). Recent studies have indicated a potential role of PTX3 in the inflammatory circuits of Rheumatoid Arthritis (*Luchetti et al.*, 2000).

1.3.7 OTHERS

Two groups of novel intracellular animal lectins have emerged from recent work on the intracellular folding and trafficking of intracellular proteins as they move from the endoplasmic reticulum (ER) through the Golgi onto the cell surface, acting as sorting receptors (*Yamashita et al.*, 1999). Among the many chaperones playing a role in the correct folding of the newly synthesised proteins in the ER, calnexin (*Hammond et al.*, 1994; *Zhang et al.*, 1995) and calreticulin participate in a quality control system for glycoproteins through their lectin-like properties (*Vassilakos et al.*, 1998).

Calnexin is a type-I membrane protein, and calreticulin is a soluble luminal protein, although both are homologous to Ca^{2+} -binding proteins. Both proteins transiently bind to N-linked glycoproteins via carbohydrate in the biosynthetic process, which is required for proper folding. Calnexin and calreticulin Ca^{2+} -dependently bind to the terminal glucose residues on the high mannose oligosaccharides (*Ware et al.*, 1995). Removal of Ca^{2+} abolishes the glycan binding character of both lectins, and this effect is reversible upon addition of the cation.

A second group of intracellular lectins appear to have a role in directing glycoproteins as they leave the ER. This group includes ERGIC-53, originally

identified as an intracellular mannose-binding lectin (*Arar et al.*, 1995), recirculating proteins between Golgi and ER (*Schindler et al.*, 1993). This group also includes VIP36 (*Fiedler et al.*, 1994), which is found in apical transport vesicles. These proteins though unrelated in sequence to other animal lectin share sequence homology to the plant lectins *viz.* ConA and other legume lectins (*Fiedler and Simons*, 1994) and could be classified as L-type lectins (*Drickamer*, 1995) (*Itin et al.*, 1996).

1.4 C-TYPE LECTINS

The C-type lectins derive their name from their dependence on divalent cations Ca^{+2} for their sugar-binding activity. The functionality of the CRD is also dependent on the interplay between the CRD and other domains (*Drickamer*, 1992). Based on the similarity in the CRDs or on the organisation of the CRDs relative to non-lectin domains, members of the lectin family have been classified into six major groups (summarised in [Figure 1-3](#)).

The dissociation constant of the monosaccharide binding to single CRD is of the order of 10^{-3} to 10^{-4} M (*Iobst and Drickamer*, 1994; *Iobst et al.*, 1994), which is rather low to ensure biologically significant response. Most of the members of the C-type lectin family circumvent this problem by oligomerisation or the clustering of the CRDs to ensure high affinity binding to multiple ligands.

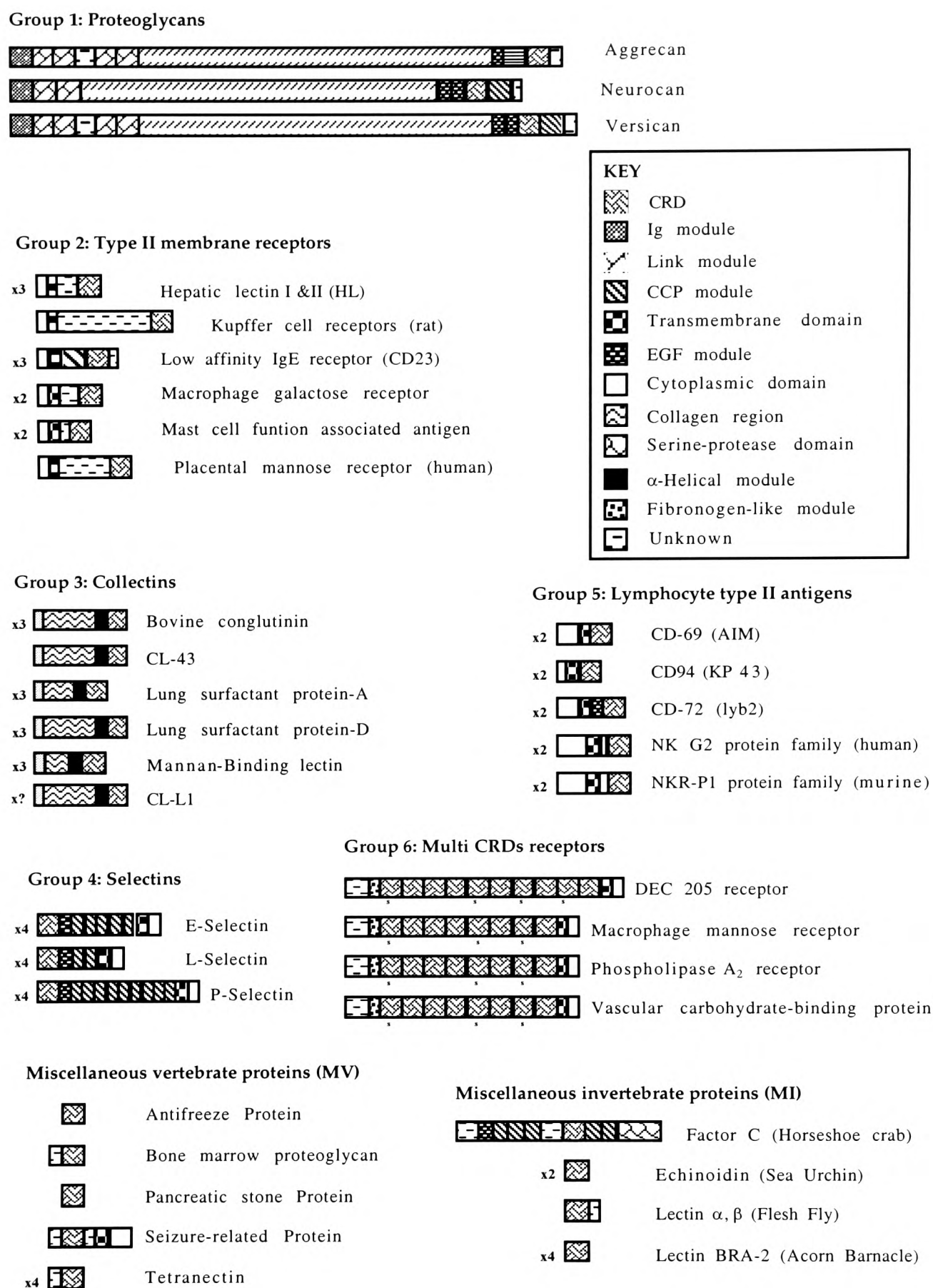

Figure 1-3: Domain organisation of the members of the C-type lectin family. Subdivisions are based on similarities of amino acid sequences of CRDs. Proteins are presented with their N-terminus to the left and if their distribution is limited to a single species, this is indicated in the name or in the following parenthesis. The letter S below the CRD refers to the presence of a short form of CRD (4 cysteine only). Miscellaneous vertebrate and invertebrate proteins are also included along with some example of invertebrate CRD-containing proteins. The oligomeric orders of the polypeptide chains found in the distinct subunits of the native protein has been indicated by x2, x3 or x4, modified from (Day, 1994).

The C-type CRD of this family is defined by a sequence motif of 115-130 amino acids, of which only 30 are conserved and include four variant cysteines and two additional conserved cysteine residues. This relatively low homology may explain the distinct carbohydrate-recognition specificities among the C-type lectins (*Drickamer, 1988*).

1.4.1 PROTEOGLYCAN

The group I protein are proteoglycan core protein which have important functions in maintaining the structural integrity of the extracellular matrix. Three types of proteoglycans have been identified: Aggrecan, Versican and Neurocan (*Margolis and Margolis, 1994*). C-type proteoglycans are multi-domain proteins composed of a C-terminal SCR (short consensus repeat), a C-type CRD, an EGF (epidermal growth factor) domain, a heavily glycosylated domain and an N-terminal link domain, forming covalent attachments with other link domains (*Schwartz et al., 1999*). Aggrecan, which is found in cartilaginous tissues, forms huge multi-molecular aggregates by interacting via its N-terminal Link modules with the polysaccharide, hyaluronate.

1.4.2 TYPE II TRANSMEMBRANE RECEPTORS

Members of the Type II transmembrane receptors are characterised by an extracellular C-terminal CRD, a neck region of varying composition often containing an α -helical coiled coil domain, a transmembrane domain and a cytoplasmic N-terminal region containing the signal peptide. This group includes human hepatic lectins I and II, also called asialoglycoprotein receptors, and are expressed in hepatic parenchymal cells. These protein have selective high affinity

for terminal gal or GlcNAc residues and are involved in the endocytosis of glycoproteins that have their terminal sialic acid residues removed (*Bischoff and Lodish, 1987*). Resident macrophages in the liver, Kupffer cells, express a type-II transmembrane receptor, also called Kupffer cell receptor, which is specific for terminal fucose and galactose and may also be involved in microbial clearance (*Hoyle and Hill, 1988*).

Other members of this group include the low affinity IgE receptor (CD23) (*Bettler et al., 1992*) (*Beavil et al., 1992*) and B-cell surface protein CD72. The binding to their ligands, IgE (*Aubry et al., 1992*) and CD5 (on T cell) (*Luo et al., 1992; Van de Velde et al., 1992*) respectively, is mediated through the CRD, which in this case seems to be a protein-protein interaction. It has also been reported that CD23 interacts with CD21 (receptor for the C3d, g and iC3b proteins of complement, for the Epstein-Barr virus, and also for IFN- alpha) via with the sugar moieties found on the complement receptor (*Aubry et al., 1994*). Another member of this family, CD69 (very early activation antigen) (*Bieber et al., 1992*) and CD23 are expressed on the surface of the dendritic cells (DC).

Bates *et al* identified a novel, DC-associated type-II surface lectin, termed DC immunoreceptor (DCIR) (*Bates et al., 1999*). Two new members of these DC-specific lectins include 'dectin-1' and 'dectin-2'. Dectin-1 is a 43 kDa membrane-associated glycoprotein (*Ariizumi et al., 2000*). Dectin-2 (isoform-2 α) and its two isoforms; dectin-2 β and dectin-2 γ , generated by alternative splicing, show similar features to dectin-1 including domain structure consisting of relatively short cytoplasmic domain, a transmembrane domain an extracellular neck region followed by a single CRD in the COOH-termini (*Ariizumi et al., 2000*).

1.4.3 COLLECTINS

The collectins are plasma proteins, involved in the innate immune surveillance by recognising the carbohydrates on the surface of pathogens. Malhotra *et al* (Malhotra *et al.*, 1992) proposed the name 'collectin' for this family of collagen-like lectins.

The six collectins (detailed in next section) that have been described till date are Bovine conglutinin (BC), Pulmonary surfactant proteins- SP-A and SP-D, Mannan-binding lectin (MBL)^b and Collectin-43 (CL-43) (Sastry and Ezekowitz, 1993) (Holmskov *et al.*, 1994) (Reid, 1993) (Table 1-3). The collectins are oligomers composed of homotrimers, where the collagen-like sequences fold to form a collagenous triple-helix and the three CRDs form the 'globular heads'. In MBL and SP-A, six homotrimers form a bouquet-like structure resembling the complement component C1q, whereas conglutinin and SP-D are composed of four subunits, which combine to form a cruciform. The collectin CL-43 seems to exist as a rod-like monomer. Recently a new member of the collectin family has been isolated from the human liver, CL-L1 (Collectin Liver 1) (Ohtani *et al.*, 1999).

^b Mannan-binding lectin (syn. Mannose-binding lectin, core-specific lectin). This protein is usually called "mannan-binding protein" or "mannose-binding protein" which both abbreviate to MBP. However, the use of the names "mannan-binding lectin" and "mannose-binding lectin" which both abbreviate to MBL (the official symbol for the gene, on chromosome 10, which encodes the protein) are perhaps preferable since the abbreviation MBP is already used for Myelin Basic protein (and is official gene symbol for the encoding gene) and is also used for the major basic protein for the eosinophils. Till date, though, there is no official IVIS recommended nomenclature ruling in the favour of using the name mannan-binding lectin or the abbreviation MBL for the description of this protein, at the protein and gene levels.

Table 1-3: Summary of morphological features of the members of collectin family. (Modified from (Drickamer and Taylor, 1993))

Subgroup morphology	Examples	Gly-X-Y repeats	Central interruption	M _r (kDa)	Possible oligomer	Ligands
Bouquet	Mannose-binding lectin-A	18	+	650-700	(α_3) ₆	Man, GlcNAc, Fuc
	Mannose-binding lectin-C	20	+	200-220	α_3	Man, Fuc
	Lung SP-A ^C	24	+	>400	(α_3) ₆	Man, Glc, Fuc, Gal
Cruciform	Conglutinin	57	-	400	(α_3) ₄	Man, Fuc, GlcNAc
	Lung SP-D	59	-		(α_3) ₄	Glc
Rod	CL-43	38	-	119-138	-	Man, Fuc, GlcNAc
	CL-L1	24	-	~120	-	Gal, Man, Fuc, GlcNAc

Besides the overall morphological similarity to C1q these lectins share another characteristic feature, the presence of multiple ligand-binding sites. This property is of great importance in the function of these proteins in agglutination, opsonisation and complement activation.

1.4.4 SELECTINS

The selectins also known as lectin-EGF-complement binding-cell adhesion molecules (LEC-CAMs), are a family of mammalian receptors implicated in the initial interactions between leukocytes and vascular endothelia, leading to lymphocyte homing, platelet binding, and neutrophil extravasation (Stoolman, 1989). These include three cell surface glycoproteins: L-selectin/CD62L (leukocyte

adhesion molecule-1 {LECAM-1}), E-selectin/CD62E (endothelial-leukocyte adhesion molecule-1 {ELAM-1}), and P-selectin/CD62P (GMP-140). Each is an integral membrane protein with an N-terminal region, a C-type lectin domain followed by an EGF-like module, two to nine copies of the consensus repeat units (complement control protein {CCP}), a transmembrane segment, and a short cytoplasmic domain (*Lasky, 1991*). The three known proteins having this structure are encoded by closely linked genes on the long arm of human and mouse chromosome 1 (*Watson et al., 1990*) (*Johnston et al., 1990*; *Collins et al., 1991*; *Larigan et al., 1992*). The CRD confers the sugar specificity to the selectins but the EGF modules seem to play an essential role by stabilising the CRD in an active conformation. All three selectins recognise the tetrasaccharide sialyl Lewis^x (Neu5Ac α 2-3Gal β -14{Fuc α 1-2}GlcNAc β -R) (*Foxall et al., 1992*) (*Jacob et al., 1995*).

E-selectin is induced in endothelial cells and is translocated to the cell surface on stimulation with thrombin. L-selectin is constitutively expressed on the surface of neutrophils, monocytes and virgin T-cells. P-selectin is constitutively expressed in platelets and stored in intracellular granules, which on stimulation with histamine or thrombin is translocated to the cell surface. All the selectins are involved in the neutrophil extravasation at the site of acute or chronic inflammation (*Lasky, 1992*), being responsible for the initial attachment of leukocytes to the vascular endothelium and their subsequent rolling on along the vessel wall (*Rossiter et al., 1997*).

^c SP-A is encoded by two genes, SP-A1 and SP-A2 with several alleles at each locus.

1.4.5 LYMPHOCYTE TYPE-II ANTIGEN

The group 5 proteins are expressed on the surface of natural killer cells or lymphocytes where they may act as antigen-recognising receptors (*Hofer et al.*, 1992) (*Hamann et al.*, 1993). These proteins have the same molecular architecture as the group 2. Protein sequence comparisons show that the group-5 proteins lack one or more amino acids that constitute a Ca^{2+} binding site and therefore it is unclear whether these proteins can bind Ca^{2+} or carbohydrate.

1.4.6 MULTI CRDS RECEPTORS

At present four members of this group have been identified, which include phospholipase A2, a novel vascular carbohydrate-binding protein, DEC-205 and the macrophage mannose receptor. The macrophage mannose receptor plays a role in the innate immune response by mediating opsonin-independent phagocytosis of pathogenic microorganisms through recognition the glycoconjugates terminating in man, fuc or GlcNAc. DEC-205 is expressed on the 'lymphoid DC', defined by their surface expression of CD8 α homodimer, and comprises of 10 distinct CRD motifs in the extracellular N-terminus (*Jiang et al.*, 1995).

The mannose receptor present on the surface of macrophages and liver endothelial cells, is a multi-domain protein (Figure 1-4) of which only some of its domains are required for the recognition of glycoconjugate ligands, viz. Man, Fuc or GlcNAc on the surface of pathogens or the terminal oligosaccharides of endogenous glycoproteins (*Taylor et al.*, 1992; *Taylor and Drickamer*, 1993). The

The gene located on the chromosome 10 (10q22.3-23.1) also contains a psuedogene.

extracellular portion includes eight Ca^{2+} -dependent CRDs, CRDs 4-8 are required for binding to terminal Man, GlcNAc or Fuc residues. However, only CRD-4 shows detectable binding to monosaccharide ligands in isolation (Mullin *et al.*, 1994) (Taylor *et al.*, 1992) (Taylor *et al.*, 1990). The presence of multiple extracellular CRDs is pertinent with its function as a scavenger receptor on the surface of the macrophages. The receptor consists of N-terminal cysteine-rich domain, the fibronectin type II repeat and the first three C-type CRDs, which do not seem to have a role in carbohydrate-recognition.

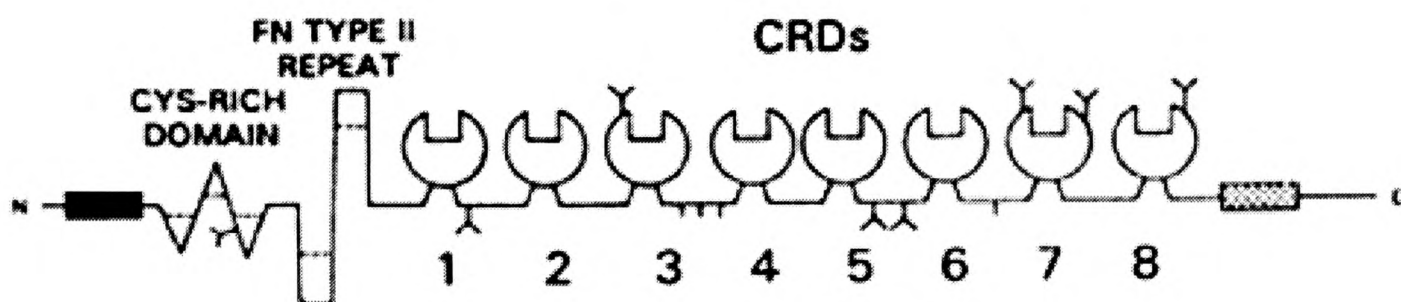

Figure 1-4: Domain organisation of the macrophage mannose receptor.

The receptor comprises eight tandemly repeated carbohydrate-recognition domains. The tinted box represents the mannose receptor signal sequence and the filled box represents the transmembrane region. The open box represents the dog preproinsulin signal sequence. Amino acids present in each construct are indicated by the residue numbers from the intact receptor. Y and I shapes represent potential or actual attachment sites for sugar to Asn and Thr respectively (Simpson *et al.*, 1999).

Mannose receptor has also been shown to be involved in the clearance of pituitary hormones such as thyrotropin and lutropin (Simpson *et al.*, 1999) soon after their action on target cells to prevent desensitisation of the receptor. Clearance of thyroid stimulating hormone (TSH) and luteinizing hormone (LH) is mediated by recognition of the terminal sulphated N-acetylgalactosamine ($\text{SO}_4\text{-4GalNAc}$) alongwith the interactions between the CRDs and oligosaccharides present on the

hormone. The binding site of SO₄-4GalNAc is localized to the N-terminal cysteine-rich domain of the receptor.

Feinberg *et al* have recently elaborated the structure of the CRD-4 (Feinberg *et al.*, 2000) by X-ray crystallography. The overall structure of the CRD-4 comprises of two α -helices and two small antiparallel β -sheets, which is similar to other C-type lectins.

1.4.7 MISCELLANEOUS C-TYPE CRDS

Proteins showing some degree of similarity to other groups of the C-type lectin family are included here. These proteins exhibit limited similarity to each other and their biological function, if known, are diverse. Tetranectin, a plasminogen binding protein, has been shown to be a cancer cell marker and is also involved in fibrinolysis. Three proteins isolated from pancreas (PSPI, PSPI-II and PSPI-III) have been implicated in pancreatic stone formation and might be involved in pancreatic regeneration.

Recently a new lectin, DC-SIGN, has been identified on the surface of the dendritic cells. DC-SIGN is a type II membrane protein with an external mannose-binding C-type lectin domain (Steinman, 2000). It has been proposed that 'DC-specific, ICAM-3 grabbing, non-integrin' interacts with ICAM-3 to establish initial contact of the dendritic cell with a resting T-cell (Geijtenbeek *et al.*, 2000). This DC-SIGN mediated loose adhesion provides an opportunity for the T-cell receptor to scan the DC surface to identify TCR ligands, which then activate the resting T-cell. This lectin has also been identified as a mediator of HIV receptor in experimental infections (Geijtenbeek *et al.*, 2000). It has been shown that langerin

can capture HIV-1 at low external titres. Without allowing viral entry, DC-SIGN retains the attached virus in an infectious state for days and then transmits it to replication-permissive T cells.

A recently identified Ca^{2+} -dependent lectin expressed exclusively in the langerhans cells, termed Langerin, shows specificity for mannose (*Valladeau et al.*, 2000). Langerin is constitutively associated with Birbeck Granules (BG), which are organelles consisting of superimposed and zippered membranes. Langerin is a potent inducer of membrane superimposition and zippering leading to the BG formation, which is a consequence of the antigen-capture function of langerin, allowing routing to these organelles and access to the non-classical antigen-processing pathway.

Other vertebrate protein members include bone marrow proteoglycans, different anti-freeze proteins isolate from arctic fish serum and a seizure-related protein (from rat brain). The invertebrate members include Factor C found in *Limulus* sp. (Horseshoe crab), Echinoidin (Sea urchin), Lectin α,β (Flesh fly) and Lectin BRA-2 (Acorn Barnacle).

1.4.8 C-TYPE LECTIN DOMAIN FOLD

Sugar-binding proteins display diverse overall architecture, but a comparison of the primary structures of these modules defines a common sequence motif, the C-type lectin domain (CTLN), in the CRD region. The structural analysis of a prototypical domain reveals that this motif largely reflects the importance of the conserved residues in establishing the fold of this type of module (*Drickamer*, 1999). However, the link-protein-type module from CD44, angiogenesis inhibitor

endostatin and bacterial adhesion molecule intimin, exhibit a topology similar to the fold initially identified in MBL, that does not stem from the sequence, which seems to have resulted from convergent evolution. Secondly, numerous structural variations in the fold have generated greater diversity in a largely conserved framework. These features have been summarised in [Figure 1-5](#).

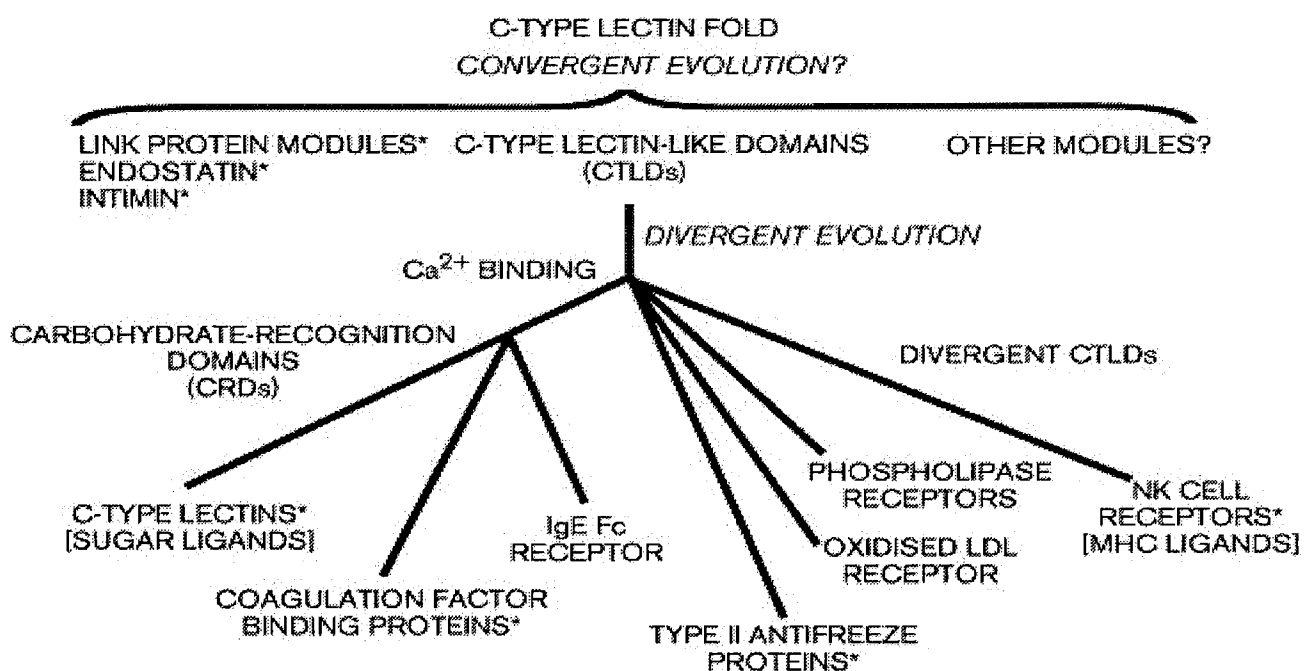

Figure 1-5: Summary of C-Type Lectin Domain (CTL D) evolution.

The convergent evolution of domains with similar folding topology is indicated at the top. The divergent evolution of the CTLDs is shown to emphasise that features such as Ca^{+2} - and sugar-binding activity are properties of only a subset of domains. The asterisk indicates modules with similar fold, but unrelated sequences. IgE, immunoglobulin E; LDL, low density lipoprotein; NK, natural killer (*Drickamer, 1999*).

1.5 COLLECTINS

The term ‘collectins’ has been coined to describe a family of non-membrane bound proteins, which have four domains, an amino-terminus that is rich in cysteines, followed by a collagen domain that is connected to the carboxyl-terminal CRD by the α -helical neck region ([Table 1-4](#)). The collectins have in common 14 invariant and 18 highly conserved amino acid residues,

including four cysteines that form a conserved disulphide-bonding pattern. The CRD appears to recognise distinct but overlapping carbohydrate ligands that decorate the cell wall of the pathogens.

Table 1-4: Principle structural features seen in collectins and complement component C1q.

Structural feature	C1q	MBL	SP-A	SP-D	BC	CL-43	CL-L1
Oligomerisation	Hexamer	Hexamer	Hexamer	Tetramer	Tetramer	Monomer	Monomer
Type(s) of chains	A, B and C	single	$\alpha 2, \alpha 3$	single	Single	Single	Single
Interruptions of collagen-like sequences	Yes (A and C)	Yes	Yes	No	Yes	No	No
Measured rod-length by E.M. (nm)	(11.2+11.5)	13.2	19.6	45.8	37.6	37	-
Association between structural units	Non-covalent	Disulphide bonds	Non-covalent, disulphide bonds	Non-covalent	Disulphide bonds	Disulphide bonds	Disulphide bonds

The collectins are multimeric proteins, the collagen regions of which appear to play a critical role in multimer assembly (Figure 1-6). The C1q-like collectins, MBL and SP-A, assemble into multimeric proteins comprised of 18 globular heads and collagen tails. This structural arrangement contrasts with that of BC and SP-D, in which the globular heads are arranged radially around the collagen spokes.

1.5.1 POLYPEPTIDE STRUCTURE

The collectins are large multimeric proteins assembled from multiple copies of a single polypeptide chain which contains a carboxy-terminal C-type

carbohydrate-recognition domain (*Drickamer, 1988*). The CRDs are spaced in a trimeric orientation, on a large fibrillar stalk of collagenous structure, which provides a defined overall structure of either an X-shape or a tulip bouquet-like appearance, separating the CRDs by a distance of up to 0.1 μ m (Figure 1-6).

1.5.1.1 N-TERMINAL DOMAIN

The N-terminal non-collagenous, sequences of the collectins show only limited similarity to each other and no homologous regions in other proteins have been reported in the protein databases. However, the cysteines residues in the N-terminal region have been shown to be conserved between conglutinin, CL-43, MBL and SP-D which are involved in the association of higher order oligomers.

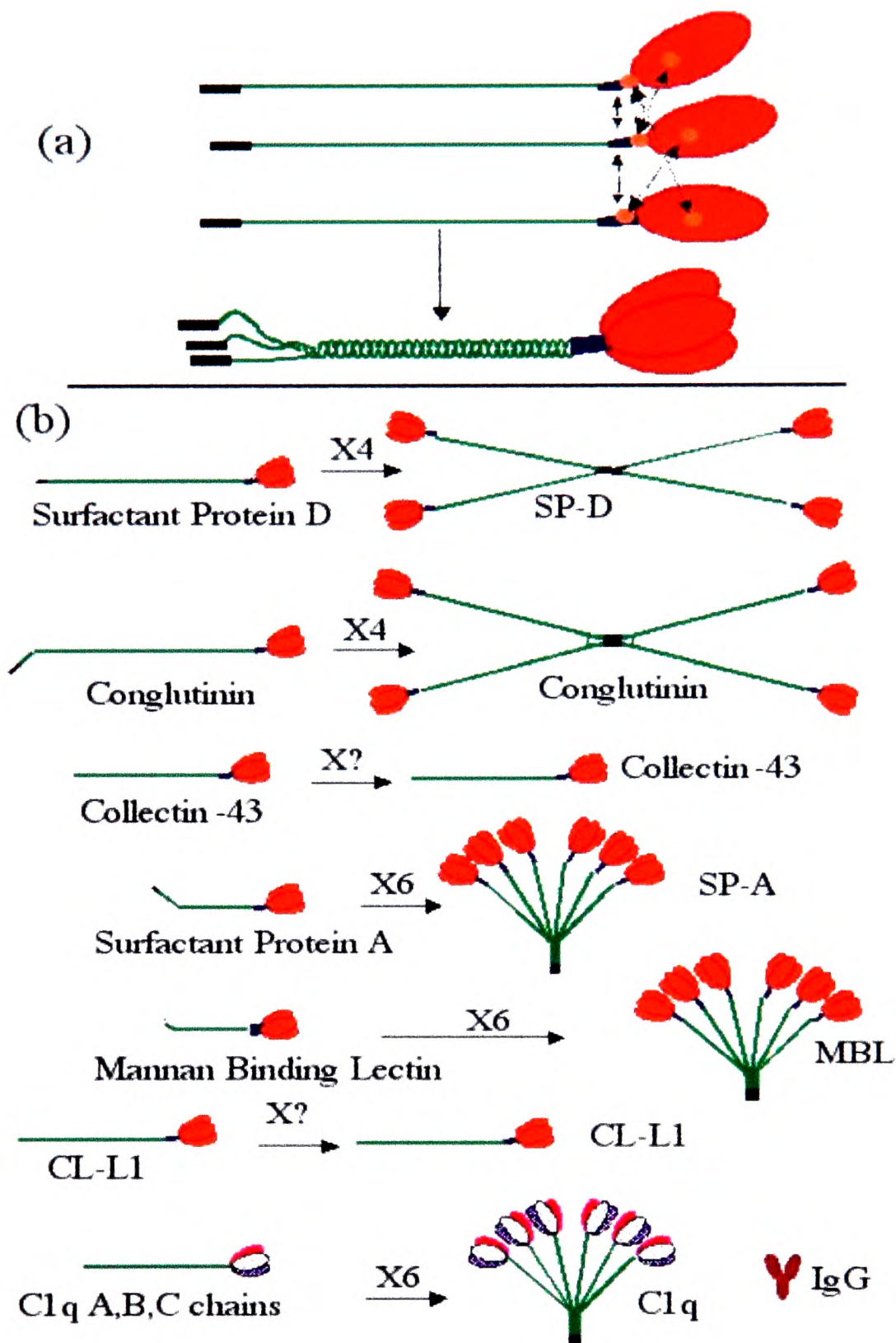

Figure 1-6: Schematic representation of formation and relationship of collectins.

(a) In collectin formation, three peptide chains, each having a C-terminal CRD (*orange*), are thought to be associated through strong hydrophobic interactions via the α -helices forming the coiled-coil part of the neck region (*brown*), whereas additional hydrophobic interactions (*yellow*) orient the CRDs relative to the neck region. The collagen triple-helix (*green*) is formed in a zipper-like fashion with the short non-collagenous N-terminal domain mediating interchain linkages through the disulphide bridges. (b) Schematic representation of the collectins and complement component C1q, as determined by electron microscopy and proteins drawn approximately to scale. The IgG molecule has been drawn to illustrate the relative dimensions. Adapted from (Hoppe and Reid, 1994).

1.5.1.2 COLLAGEN-LIKE DOMAIN

A prerequisite of the correct folding to form an intact triple helix is the correct alignment and association of three polypeptide chains containing the collagenous region. The collagen stalk consists of Gly-Xaa-Yaa triplets, where Xaa and Yaa can be any amino acids. Every third residue of each collagenous repeat needs to be a glycine because an amino acid with a bulky side-chain would not fit into the centre of the triple helix, where the three chains come together at every third residue, shifted by 30° from the preceding central residue of the same chain (*Bella et al.*, 1994). There is an absolute requirement for the correct alignment of the three chains because all the backbone hydrogen bonds in a collagen triple-helix are inter-chain and the highly repetitive Gly-Xaa-Yaa sequences forms short regions of mismatched triple helices if the registration is not correct (*Traub and Piez*, 1971). The folding of the chains to form the triple helix always proceeds from the C- to the N-terminal (*Dolz et al.*, 1988).

The collagen region in the collectins undergoes post-translation modifications including glycosylation and hydroxylation of the lysine and proline residues. Many of the proline and lysine residues in the Yaa position are hydroxylated giving hydroxyprolines and hydroxylysines, respectively. Hydroxylysines are known to stabilise the collagen triple-helix (*Sakakibara et al.*, 1973) and probably perform the same function in the collectins.

1.5.1.3 NECK REGION

The short stretch of 34-41 amino acid residues, the neck region, is known to form a triple-stranded α -helical coiled coil in a parallel, non-staggered and non-

covalent association via hydrophobic interactions with the equivalent regions of the other two chains (*Hoppe et al.*, 1994). The term 'neck region' was originally introduced to describe a protease-resistant peptide fragment comprising a short stretch of amino acids linking the collagenous region with the CRD. It was subsequently found to be encoded by a separate exon. The neck region consists of two parts: an amino-terminal α -helical coiled coil that can associate into trimers and the other, by continuation of the α -helical structure, can interact with the globular head structure as shown in Figure 1-6a.

The α -helical wheel projection of the sequences corresponding to the coiled coil of the SP-D neck region show the hydrophobic residues form a heptad repeat (*Hoppe and Reid*, 1994). The neck region also serves as the nucleation site for the trimerisation of the CRDs and for the folding of the collagen regions (*Hoppe and Reid*, 1994).

1.5.1.4 CARBOHYDRATE RECOGNITION DOMAIN

Collectins contain a lectin domain, which is of calcium-dependent type. This carbohydrate-binding domain comprises of about 114-118 amino acids with 14 invariant and 18 highly conserved residues, including four cysteine residues. These four cysteine residues give a conserved disulphide binding pattern: 1-4 and 2-3 (*Drickamer*, 1988). Structural studies on rat MBL revealed two striking features: the N- and C-terminal ends of the CRD are in close proximity to each other, making it an ideal domain to link to the N- or the C-termini of a polypeptide chain. Secondly, the structure appears to be divided by two transverse β -strands that separate a compact scaffold of two α -helices and two β -sheets, with the N- and

C-termini, from an extensive loop that consists of the binding sites for two calcium ions as well as for the carbohydrate ligand (*Weis et al.*, 1991) (discussed in section 1.6). The binding sites for the calcium and sugar residues are located on the same side of the domains.

In rat MBL-A, the sugar-binding residues: Glu185, Asn187, Glu193 and Asn205, which form co-ordinate bonds with the calcium ion and hydrogen bonds with the 3-OH and 4-OH groups of mannose and Asp206 are found to be conserved in the sugar-binding C-type lectin domains. Two of the five residues responsible for complexing calcium ion, involved in carbohydrate-binding, namely Glu185 and Asn187 within the sequence Glu-Pro-Asn-X-Trp-Asn-Asp, were found to be predominantly involved in determining the carbohydrate specificity. A change of these two residues to Gln185 and Asp187 resulted in a change of specificity to galactose (*Drickamer*, 1992). Based on sequence alignments, collectins: MBL, BC, SP-D and CL-43 belong to mannose type carbohydrate-binding family whereas SP-A assumes a hybrid position between collectins and galactose-specific lectins (*Haagsman et al.*, 1987). The preference for hydroxyl groups of the mannose- or galactose-type within the binding-site on the carbohydrate molecules is determined by the Glu-Asn/Gln-Asp pair of residues. However, other differences seen in the sequences of the lectin domains and in particular of the extensive loop carrying the binding sites, also seem to be involved in the ligand selection in the *in vivo* interactions of the collectins with the complex carbohydrate structure (*Hoppe and Reid*, 1994).

An important feature of the C-type lectin domain is the very low affinity of a single domain for its ligand (of the order of mM), whereby the biological

functional relevance is mediated by the oligomerisation of these molecules. Structural factors influencing carbohydrate binding seem to be determined at three distinct levels: firstly, by the amino acid residues directly involved in the binding (as discussed above); secondly, steric hindrance either by the protein or the carbohydrate structure thereby restricting access to the respective binding sites, and finally, the spacing of the epitopes on the ligands, which need to match the position of the lectin domains in a given lectin. The overall structure of the collectin molecule may also confer additional specificity in the *in vivo* situation.

1.5.2 INTERACTION WITH COMPLEMENT SYSTEM

The involvement of mammalian lectins in the activation of the serum complement system, or in the utilisation of activated complement components or complement receptors provides antibody-independent pathways for the recognition and clearance of potential pathogens. These types of defence mechanisms can be of considerable importance in neonates and immunodeficient individuals.

The complement system is a major component of immune defence against infection, consisting of nearly 30 soluble (plasma) proteins and cell-surface proteins. A major function of the complement system is to recognise non-self material in the circulation and tissue spaces, by antibody-dependent or -independent pathways. Such non-self materials include microorganisms and breakdown products of the body's own cells. Activation of the complement system proceeds through enzymatic amplification steps and is tightly regulated by specific proteins, which not only limit the extent of activation but also protect the host cells from potential complement-mediated injury. Complement proteins or other

complement-associated non-antibody proteins, recognise and bind to the surface features of microorganisms or other particulate material mediating their clearance by opsonisation/phagocytosis and cell lysis, together with the neutrophil chemotaxis. Carbohydrate-containing structures on the targets are of major importance in this type of interaction.

Activation is necessary for the expression of biological activities of the complement system. Despite the participation of multiple structurally and functionally diverse proteins, complement activation is characterised by remarkable operational simplicity. In humans and other mammals, complement activation is initiated by a variety of pathogens and foreign molecules recognised either directly by complement proteins or indirectly through recognition molecules from other host defence systems, such as antibodies and soluble defence collagens. Mammalian lectins may utilise complement components and/or receptors through at least three different routes (summarised in [Figure 1-7](#)).

First, the best-characterised route is via the activation of classical pathway of complement, as brought about by the interaction of serum mannan-binding lectin (MBL) after binding with suitable carbohydrate ligands. MBL can become involved with the complement activation at C1 stage, by mimicking the activation property of C1q in the C1 complex. C1 activation leads to deposition of C4b and C3b on the target cell, thereby recruiting the C4b and C3b receptors. Further activation of the complement system can result in the lysis of the target by the deposition of the terminal complement components (C5-C9). MBL also mediate complement activation through a similar but independent pathway. MBL circulates in the blood as a complex with the two associated serine proteases, MASP1 and

MASP2 (Thiel *et al.*, 1997). MBL recognises carbohydrate moieties on the surface on the microorganism through multiple CRDs. The binding of MBL to an activating surface results in the activation of MASP1 and MASP2, which can lead to cleavage of C4 and C2. This leads to the formation of the same C3, in an analogous manner to the classical C1 activation pathway, consequently forming C5 convertases (C4bC2a and C3bC4bC2a).

Second, collectins which include MBL, conglutinin, and the lung surfactant proteins A and D (SP-A and SP-D), all bind to the C1q and collectin receptors, found on the surface of the phagocytic cells, via their collagen-like regions. Triggering of C1q/Collectin receptors is considered to result in a number of biological events including phagocytosis, modulation of cytokine and immunoglobulin secretion and PMN-endothelial interactions.

Thirdly, conglutinin, which is a member of the collectin family, shows specific binding to the terminal sugars carbohydrate chain, which becomes exposed, on the α' -chain of iC3b during the processing of the activated C3. This binding can enhance phagocytosis of the iC3b-coated target cells by increasing contact between the target and effector cells.

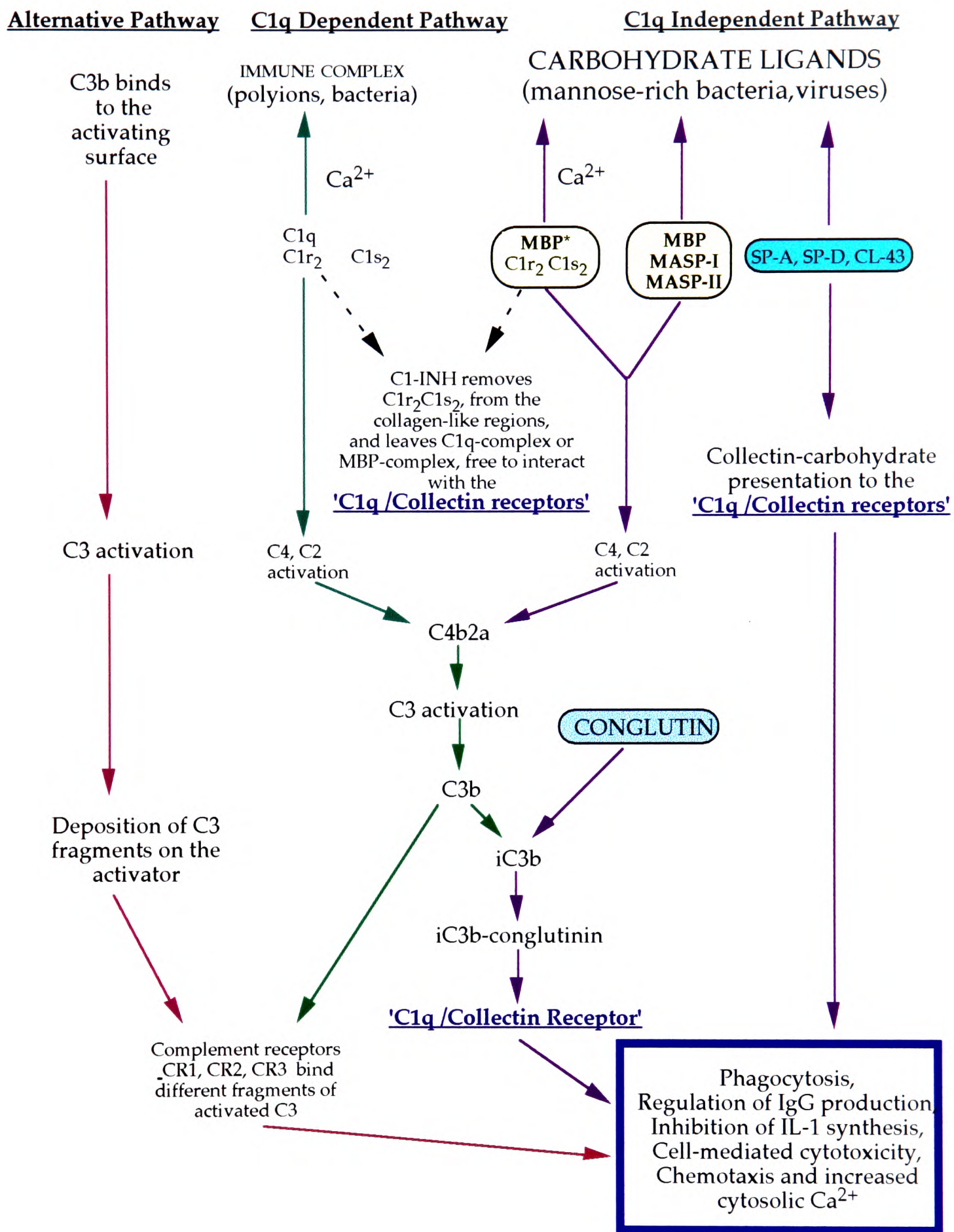

Figure 1-7: Schematic representation of interactions of collectins with complement components and their physiological significance.

1.6 MANNAN-BINDING LECTIN

Mannan-binding lectin, also known as mannose-binding lectin and core-specific lectin, was first isolated from the cytosolic fractions of rabbit liver (*Kawasaki et al.*, 1978). Similar proteins able to bind mannose-terminal glycoproteins were subsequently isolated from rat and human livers (*Wild et al.*, 1983) and in human (*Kawasaki et al.*, 1983), bovine (*Kawasaki et al.*, 1985), rat (*Oka et al.*, 1988), mouse (*Sastry et al.*, 1991) and rabbit (*Kozutsumi et al.*, 1980) serum.

MBL is the best characterised among the collectins and the studies on rat, mouse and human MBL have provided most of the structural information on the protein. In each of the three species, the protein exists as a hexamer of trimers of an identical polypeptide chain of 32-kDa. The chain is characterised by three distinctive regions: (i) a cysteine-rich N-terminal region which mediates inter-chain disulphide bonding; (ii) a collagenous region with 19 Gly-X-Y repeats, and (iii) a C-terminal region of 148-155 amino acids that requires Ca^{2+} to bind ligands. Most of the latter (115-130) comprises the CRD. Three such chains associate through disulphide bonding and the formation of collagenous α -helix to form a trimeric subunit. The trimeric form of MBL is essential for the assembly of higher order multimers that increase the avidity for apparently disparate non-self oligosaccharides.

Two homologous, yet distinct forms of MBL have been described in rats and mice, namely MBL-A and MBL-C (*Sastry et al.*, 1991) (*Lee et al.*, 1991). The mouse and rat MBL-A are 90% identical with a single gap in the collagenous

region and an extra proline in the signal peptide of the mouse MBL-A. The MBL-C forms are characterised by the insertion of nine amino acid residues in the amino-terminal cysteine-rich region and are 82% identical to each other. In human protein incorporates the features of both sequences, containing the nine amino acid residues in the N-terminal region and the gap in the collagenous region.

1.6.1 STRUCTURE

Functionally, MBL binds mannose-containing oligosaccharide structures typical of those found on the surface of the microorganisms. Binding studies aimed at probing the subunit organisation of MBL, have shown that it binds most tightly to neoglycoproteins that display widely spaced carbohydrate determinants (*Lee et al.*, 1992). The X-ray crystal structure (Figure 1-8) reveals that the CRDs are spaced $\sim 53\text{\AA}$ and $\sim 45\text{\AA}$ apart in the rat and human MBL respectively. This separation clearly precludes that a small branched oligosaccharide could span binding sites within the trimer. However, consistent with a role in binding mannose residues presented on a cell-surface, the binding sites are found on only one face of the trimer. The observed flexibility in the neck/CRD orientation also suggests a means of facilitating interactions with these cell-surface determinants.

Analysis of the acceptor and ligand together clarified the relationship of atomic components of the penultimate mannose residue of the oligosaccharide to the amino acid and Ca^{2+} ions in the carbohydrate binding site of the protein (*Weis et al.*, 1992). The carbohydrate binding site is located in the large loop that arises from a tight core domain composed of two helices, two β sheets and two β strands (Figure 1-8B). The loop contains three Ca^{2+} binding sites, one located in the sugar

binding site (denoted #2 Ca^{2+}), and the two located closer to the origin of the loop (denoted #1 and #3 Ca^{2+}). The #3 Ca^{2+} binding site was thought to be artifactual.

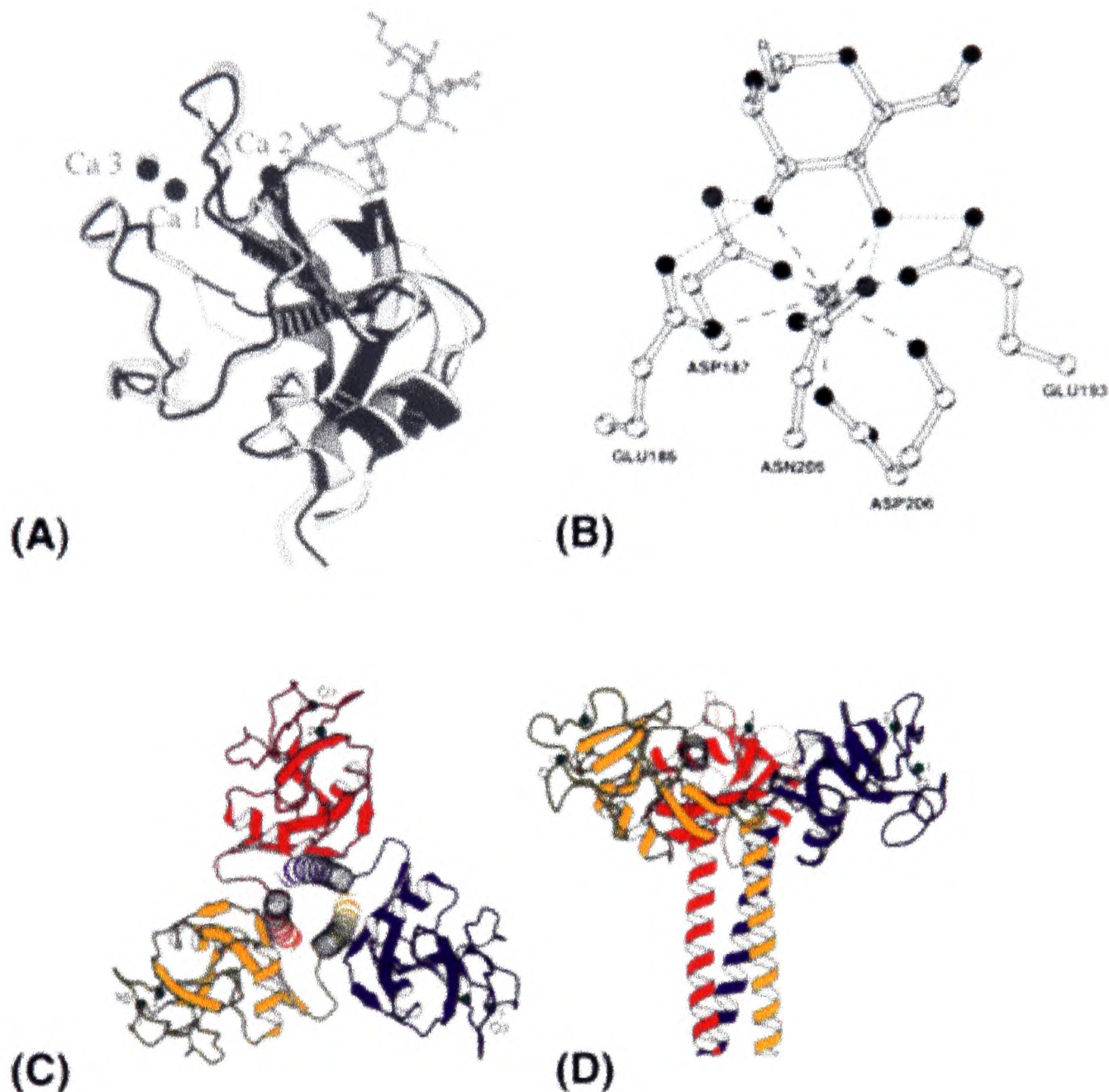

Figure 1-8: Schematic representation of the structural features of the Mannan-binding lectin.

(a) The Ca^{2+} and carbohydrate binding site of MBL-A. (b) X-ray diffraction analysis of an MBL-A-oligosaccharide complex revealed the relative positions of Glu¹⁸⁵, Asn¹⁸⁷, Glu¹⁹³, Asn²⁰⁵ and Asp²⁰⁶ of the carbohydrate binding site, a Ca^{2+} ion and the terminal mannose residue of the ligand. The Ca^{2+} ion is anchored by coordinate bonds and hydrogen bonds with oxygen atoms from all five residues. (c) View of the trimer down the three-fold axis, looking from CRD towards the amino-terminus. (d) A view of the trimer perpendicular to the three-fold axis. The tight turn between the neck and CRD can be seen in the front on the yellow protomer (Weis *et al.*, 1992; Weis and Drickamer, 1994).

The diffraction analysis revealed that the carbohydrate is bound by a network of Ca^{2+} co-ordinate bonds and hydrogen bonds (*Drickamer, 1997*). The #2 Ca^{2+} ion was complexed with oxygen atoms from the side chains of Glu¹⁸⁵, Asn¹⁸⁷, Glu¹⁹³, Asn²⁰⁵ and Asp²⁰⁶ (Figure 1-8B). The 3' and 4' equatorial hydroxyl groups of mannose also formed Ca^{2+} coordinate bonds as well as hydrogen bonds with amine and carbonyl side chains of Glu¹⁸⁵, Asn¹⁸⁷, Glu¹⁹³ and Asn²⁰⁵. Subsequently site-directed mutagenesis studies confirmed the crystallographic evidence that Van der Waals interactions between sugar and the imidazole ring of His¹⁸⁹ and carbon atoms of Ile²⁰⁷ also contributed to binding (*Iobst et al., 1994*). Thus the binding of mannose to individual CRDs of MPL-A is due to a collection of relatively weak interactions. The affinity of MBL-A for ligands is greatly increased by the simultaneous binding of multiple CRDs of each oligomer to the sugar, lipid or protein target (*Lee et al., 1992*).

1.6.2 PROPERTIES

Carbohydrate specificity of MBL is rather broad, including D-mannose, GlcNAc and L-fucose, in accordance with its need to recognise a myriad of pathogenic cell-surfaces (*Lee et al., 1991; Lee et al., 1992*). The collagen-like domain is proposed to be involved in the interactions with the serine-proteases i.e. MASP-1 (*Matsushita and Fujita, 1992*) and MASP-2 (*Thiel et al., 1997*), in the complement cascade (*Kurata et al., 1993*) and with the cell surface receptors such as the C1q receptor (*Malhotra, 1993; Tenner, 1993*) or collectin receptor (summarised in Figure 1-7) (*Malhotra et al., 1994*). Recently, it has been shown that MBL exhibit viral neutralisation and inhibition of viral spread without the

involvement of complement components (*Kase et al.*, 1999), which have been previously shown to be complement-mediated (*Anders et al.*, 1994).

1.7 BOVINE CONGLUTININ

Conglutinin was the first mammalian lectin to be discovered. It was described at the beginning of the century, by Bordet and Gay, as a component of bovine serum capable of agglutinating alexinated erythrocytes (i.e. erythrocytes reacted with antibody and complement) upon incubation with heat-treated ox serum (*Bordet and Streng*, 1909). This phenomenon was termed conglutination, and the active component in the bovine serum responsible for the effect as conglutinin (*Bordet and Streng*, 1909). Later it was shown that conglutination was mediated by binding of conglutinin to the complement component iC3b covalently attached to the erythrocytes (*Lachmann and Muller-Eberhard*, 1968; *Hirani et al.*, 1985; *Laurson et al.*, 1994; *Solis et al.*, 1994). Amino acid analysis of conglutinin revealed the presence of a collagen-like region, containing Gly-X-Y triplet sequences, which led to its inclusion as a member of the collectin family (*Lee et al.*, 1991)

1.7.1 BIOSYNTHESIS & SECRETION

Conglutinin has until now been described as a circulating molecule. Immunohistochemical staining for conglutinin shows universal and intense cytoplasmic staining of the hepatocytes, indicating liver as the main site of synthesis (*Lu et al.*, 1993) for plasma BC. Some immunoreactive BC was also observed in follicular dendritic cells (FDC) in the lymphoid follicles of spleen, tonsils and lymph nodes. Some staining was also found corresponding to

endothelial cells in some tissues (*Holmskov et al.*, 1992). Macrophages from liver, lung, thymus and spleen also expressed BC immunoreactivity. However, northern blot analysis revealed the presence of mRNA for conglutinin in liver only (*Lu et al.*, 1993).

Conglutinin has been identified only in *bovidae*, the presence of homologues of conglutinin in human serum is still controversial although there have been some reports of a protein homologous to bovine conglutinin in human plasma (*Jensenius et al.*, 1985; *Baatrup et al.*, 1987; *Thiel et al.*, 1987; *Ushijima et al.*, 1992).

1.7.2 PROPERTIES

Conglutinin is purified from bovine serum through euglobulin precipitation and interaction with zymosan, the insoluble yeast wall carbohydrate, using elution with sugars or EDTA (*Lachmann*, 1967).

It was first described as a highly asymmetric molecule with a sedimentation coefficient of about 7S, a diffusion coefficient of $0.9 \times 10^{-7} \text{ cm}^2 \text{ sec}^{-1}$ and a calculated molecular mass of 750 kDa (*Lachmann*, 1967). On gel permeation chromatography, conglutinin elutes in a peak corresponding to a Mr of about 1000 kDa. After further purification by ion-exchange chromatography, a single polypeptide chain is observed with a molecular mass of 44kDa on SDS-PAGE under reducing conditions. Under non-reducing conditions, conglutinin shows a complex pattern, with a ladder of molecular forms corresponding to free polypeptides, dimers, trimers and so on, having apparent molecular masses ranging from 37-260 kDa, suggesting a complexity in the pattern of disulphide linkage

(*Jensenius et al.*, 1985). The main band has an apparent mass of 260 kDa, suggesting that the two subunits are linked by disulphide bonds and that two such dimers are linked by non-covalent interactions. However, only one N-terminal amino acid sequence of the intact form has been found (*Davis and Lachmann*, 1984), suggesting that the molecule is a multimer of identical polypeptides.

Variable amounts of a truncated form (having a reduced Mr of 38 kDa) are also seen and these amounts often increase upon storage and are likely to be the result of degradation by contaminating plasmin.

The molecular mass of the single polypeptide chain of conglutinin, as estimated from the sequence (*Lee et al.*, 1991), is 35.1 kDa. The M_r values found on the SDS-PAGE maybe overestimated as a result of slow migration in the gel of collagenous protein as compared to globular proteins. Recently, the mass of the single chain of conglutinin has been determined by mass spectrometry to be 39.680 ± 1 kDa. The discrepancy between the estimated mass and the mass determined by mass spectrometry is probably due to post-translation hydroxylations and additions of O-linked carbohydrates, mainly in the collagen region. One potential site for N-linked glycosylation is found in conglutinin which involves the residues Asn³¹⁷, Asn³¹⁸, Ser³¹⁹ and since, Asn³¹⁷ is one of the residues involved in sugar binding, it seems unlikely that this site is glycosylated (*Drickamer*, 1992).

The intact polypeptide of conglutinin shows four isoforms with pIs ranging from 5.3 to 6.1 (*Holmskov and Jensenius*, 1993). The different isoforms may be due to allelic variation of the molecule, as polymorphism has been described in the conglutinin gene (*Liou et al.*, 1994).

1.7.3 STRUCTURE

The complete amino acid sequence of conglutinin was resolved through protein sequencing (*Lee et al.*, 1991) (Figure 1-9). BC has subsequently been cloned and sequenced by various groups both at cDNA levels (*Lu et al.*, 1993; *Liou et al.*, 1994) and genomic levels (*Kawasaki et al.*, 1994). This showed one difference at position 190 with Lys, instead of serine as determined by amino acid analysis. The sequence shows that BC is homologous to other members of the collectin family and shows 79% identity with human SP-D (Figure 1-9).

The cDNA of conglutinin encodes a polypeptide of 351 amino acid residues. The short N-terminal non-collagenous sequence contains 2 cysteines, conserved in all collectins and involved in the covalent cross-linking of the polypeptide chains, followed by a stretch of 171 residues forming 57 Gly-Xaa-Yaa triplets, except for the fifth triplet, where Gly is replaced by Cys.

This interruption may be responsible for the bend in the collagen of the conglutinin observed in electron microscopy (*Strang et al.*, 1986; *Lu et al.*, 1993) and may introduce flexibility into the collagenous arms. It has also been suggested that this cysteine is involved in the quaternary organisation of the molecule.



Figure 1-9: Sequence comparison of Bovine Conglutinin and Surfactant Protein-D.

Residue 1 denotes the N-terminal residue of Bovine conglutinin. Residues identical in both BC and hSP-D are indicated by (•), residues considered to be involved in sugar-binding are denoted by (+). The sequence of the recombinant BC used in this study has been highlighted in green and that of SP-D in yellow. The N-terminal region of BC in the clone rBC(Δ coll) has been highlighted in blue, that is followed by the neck and CRD.

The collagen region is followed by a short neck region of 28 residues.

This region, in analogy with SP-D and MBL, is likely to form an α -helical coiled-coil structure connecting the collagenous region with the C-terminal CRD of 127

residues and may also be the focus for initiating the formation of the triple collagen helix (*Hoppe et al.*, 1994). Eight hydroxylysines residues are found in the collagenous regions, all of which occupy Y position in the Gly-X-Y triplet except for Lys102, that may act as glycosylation sites. The CRD region has four invariant cysteine residues, forming disulphide bridges between 1 and 4, and 2 and 3.

1.7.4 OVERALL STRUCTURE

Conglutinin is built of subunits, each composed of three identical polypeptides, four of which form a tetramer of trimers, resembling the Greek cross, with flexible arms of 38 nm ending in globular heads (*Jensenius et al.*, 1994). The total span of conglutinin is about 90 nm and only a little BC is recovered in the filtrate after passage through a 0.2 μm filter. The presence of monomers, dimers and trimers is seen to a varying extent (*Lu et al.*, 1993).

BC is the only lectin described for which conformational changes of the sugar presenting peptide markedly influences the recognition of the sugar (*Jensenius et al.*, 1994). The secondary structure of the recombinant CRD of Mannose binding protein in complex with high mannose oligosaccharide, has been determined by X-ray crystallography (*Weis et al.*, 1992). The similarities in the sequence and function suggests that conglutinin will present a similar folding pattern i.e. two α -helical and a β -pleated sheet forming the structural platform, stabilised by two disulphide bonds, for the residues generating the two calcium binding sites and making contact with the sugar.

1.7.5 INTERACTION WITH SUGARS

BC shows the highest binding affinity for GlcNAc, which is the most potent inhibitor of conglutination of complement-reacted erythrocytes (*Young and Leon, 1987*). It shows high affinity to zymosan and mannan: a soluble polysaccharide prepared from the cell wall of yeast, *Saccharomyces cerevisiae*. Further elucidation of the carbohydrate affinity, by inhibition of binding to mannan by sugars, revealed the most potent inhibitors as the D-sugars with equatorial 3- and 4- hydroxyl (OH) groups, with the exception of L-fucose (which has 2- and 3-equatorial OH groups).

1.7.6 INTERACTION WITH COMPLEMENT SYSTEM COMPONENTS

The biological activity of BC is known to be mediated by binding of conglutinin to the carbohydrate moiety on the α chain of iC3b (*Lachmann, 1967; Hirani et al., 1985*). It is well established that conglutinin binds to the single high mannose oligosaccharide structure containing terminal α' 1-2 linkages, at Asn⁹¹⁷, on the α -chain of the C3, when C3 is in the form of iC3b (*Lachmann, 1967*), and not to the high-mannose oligosaccharide on the β -chain which contains α 1-3 and α 1-6 mannosyl linkages (*Hirani et al., 1985*). The binding of conglutinin to iC3b requires calcium ions and can be inhibited by GlcNAc (*Lachmann, 1967*) and to some extent by L-fucose (*Leon and Yokohari, 1964*). A preference for terminal non-reducing α 1-2 linkage was also observed in inhibition of agglutination and by examination of the binding of conglutinin to neo-glycolipids separated by thin layer chromatography, which also showed binding to complex-type

oligosaccharides with non-reducing terminal GlcNAc, Man and Fuc (*Mizuochi et al.*, 1989).

1.7.7 INTERACTIONS WITH MICROORGANISMS

A number of observations implicate BC in the innate immune defence by binding directly to the carbohydrate residues on the surface of the microorganisms or by interacting with complement component, iC3b, thereby facilitating phagocytosis and antigen presentation (summarised in Figure 1-7). BC shows opsonising activity towards *Salmonella typhimurium* and *Escherichia coli* (*Friis et al.*, 1991). Conglutinin has been shown to inhibit haemagglutination by influenza A virus. It is mediated by the binding to the high mannose carbohydrate attachments on the haemagglutinin and through the same mechanism causes the aggregation of IAV particles. Preincubation of IAV with conglutinin markedly potentiates the respiratory burst in neutrophils in response to the virus and also significantly reduced the neutrophil deactivation than the untreated virus.

1.8 COLLECTIN-43

Collectin-43 was first identified on the SDS-PAGE of conglutinin preparations, as a protein band 1-kDa less than conglutinin (44kDa). N-terminal sequencing identified this band as a new protein and the presence of collagenous sequence prompted the name Collectin-43-or CL-43. As with the conglutinin, CL-43 has been identified in Bovidae only.

Under non-reducing conditions, CL-43 show a single band corresponding to a Mr of 120-kDa. The molecular mass of the single polypeptide, as calculated from sequence is 31.5-kDa (*Lim et al.*, 1994). The mass of reduced CL-43 is

estimated to be 33.6 ± 0.1 kDa, as determined by mass spectroscopy. This discrepancy is due to a large number of post-translational modifications in the collagenous regions. All proline-residues located in the Yaa-position have been found to be partially hydroxylated while all the lysines in the Yaa-position were fully hydroxylated and glycosylated (*Rothmann et al.*, 1997). Isoelectric focussing of CL-43 revealed only one isoform of the intact polypeptide, with a pI of 4.9 (*Holmskov et al.*, 1995). The EM studies show CL-43 as a monomer with a rod-length of 37 nm.

The cDNA and mRNA analysis of CL-43 revealed the polypeptide to be composed of 301 amino acid residues, containing 28 residues, followed by a collagenous region of 114 residues consisting of 38 Gly-X-Y repeats, a neck region of 31 residues and a CRD of 128 amino acids (*Lim et al.*, 1994). CL-43 shares 74 % amino acid sequence identity with BC.

Sugar-binding studies showed CL-43 to demonstrate affinity for L-fucose and for Man in the non-reducing ends of high-mannose type oligosaccharide chains. In contrast to BC, CL-43 does not show affinity for oligosaccharides containing non-reducing GlcNAc (*Loveless et al.*, 1995).

Recent evidence from *in vitro* studies (*Reading et al.*, 1998), demonstrate haemagglutination-inhibition and neutralisation activity of CL-43 against influenza virus, thus representing the second β -inhibitor in bovine serum. In comparison with the other bovine collectins, conglutinin and SP-D, CL-43 displayed higher anti-viral activity against all four bovine rotavirus strains. This binding may block the

rotavirus-integrin interaction, and would represent a possible virus-neutralisation mechanism by collectins.

1.9 CL-L1

Ohtani *et al.*, recently identified a novel human collectin, CL-L1, in liver (Ohtani *et al.*, 1999). CL-L1 is a ~40-kDa protein having the same structural and domain organisation as the other collectins. CL-L1 is mainly expressed in liver, placenta and adrenal glands and is expressed ubiquitously in most tissues except skeletal muscles. This new collectin is considered to be a cytosolic protein, although all other collectins are secreted proteins and may interact with intracellular ligands.

This new collectin consists of 277 amino acid residues and has the four major domains: an N-terminal domain, a collagen-like domain, a neck domain and a CRD. However, CL-L1 has only one cysteine in its N-terminal region and 24 Gly-X-Y repeats in the collagen region, which has no interruptions in the triplets. The collagen-like domain has five prolines and twelve lysine residues, which are hydroxylated as in other collectins. The neck region is a variable domain consisting of the hydrophobic residues which form the α -helical coiled coil (Hoppe *et al.*, 1994; Sheriff *et al.*, 1994). The four cysteines and the 14 amino acid residues, which form the CRD frame in CL-L1, are conserved. The four lysines residues at the C-terminal of the polypeptide chain constitute the most characteristic motif.

The CL-L1 gene is located on chromosome 8q23-q24.1, in contrast to the collectin gene cluster on the chromosome 10. The CRD contains a novel C-terminal lysine residue cluster, which is similar to the motif for the receptor site of

the macrophage scavenger receptor. It shows low affinity for galactose as well as mannose, fucose and N-acetylglucosamine. These findings suggest that CL-L1 may play a role as a scavenger or chaperonin in the cytoplasm. The phylogenetic relationship (Figure 1-19) between CL-L1 and other collectins suggests that CL-L1 may belong to a novel group in the collectin family.

1.10 PULMONARY SYSTEM OVERVIEW

The respiratory tract begins at the alae of the nose and mouth, coursing through the nasopharynx, larynx, trachea, about 16 generations of symmetrical branches of bronchi and the respiratory bronchioles and terminates with the alveolar units where the actual gas exchange occurs. The respiratory tract has three distinct regions: naso-oropharynx, thoracic and bronchial conducting airways and the alveolar acinar units.

The conducting airways are lined with a mucosal surface, which includes an epithelium, a basement membrane and the lamina propria. A pseudostratified columnar, ciliated epithelium lines the nasal turbinates and tracheobronchial tree down to the respiratory bronchioles, except in the nares and larynx that are lined by squamous epithelium. In the lower peripheral airways, this epithelium becomes thinner and less stratified, and the cells are more cuboidal with shorter cilia. Eventually it flattens into a single layer of epithelium in the alveolar ducts and alveoli.

Three types of cells are interspersed in the respiratory epithelium: type-II cells, Clara cells and perhaps the serous cells. These cells along with the bronchial glands located in the submucosa discharge fluid or lubricant for the mucosal

surface. The alveolar epithelium consists of Clara cells and the type II cells, which secrete surfactant components. The surfactant lipids lower the contractile force of the air-liquid interface, reducing both the tendency of the alveoli to collapse at end expiration, thereby maintaining the normal volume stability of the lung at low transpulmonary pressures, and the transudation of fluid into the air spaces. The surfactant-associated apoproteins have been shown to mediate the host immune defence against the inhaled microorganisms.

1.10.1 IMMUNOLOGIC COMPONENTS OF THE AIRWAYS

The lungs provide an interface between the external and the internal milieu and have thus evolved complex sets of host defences, employing mechanical barriers and intricate cellular and humoral immune systems, to protect against infection and injury to delicate absorptive surfaces (Figure 1-10). Airborne particulates and microorganisms inhaled into the lung are deposited within a two-cell thickness of the bloodstream.

In the upper respiratory tracts, the secretory immunoglobulins present in the mucus film, the lymphoid tissues and the roaming immune cells form the defence system. The surface immunoglobulins in the airways are a mixture of polymeric IgA, IgE and IgG, principally secreted by plasma cells dispersed along the airways in the lamina propria. The respiratory tract has ample lymphoid components. In the mediastinum, the immune defence system comprises of the lymph nodes around the trachea, carina and main stem bronchi, the hilar lymph node complex.

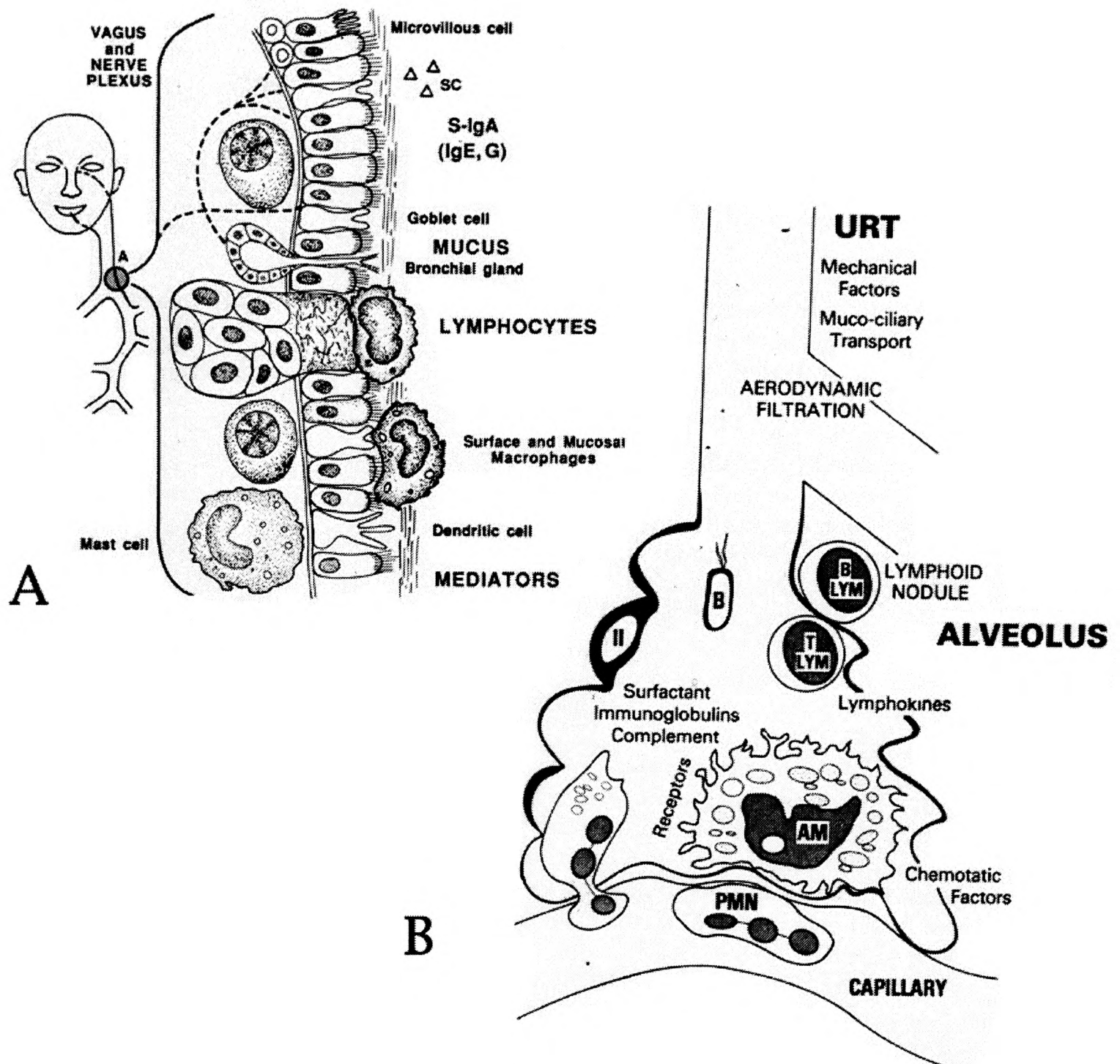

Figure 1-10: Diagrammatic representation of the components of the host immune system active in the pulmonary system.

(A) Portion of the respiratory tract surface has been enlarged depicting mucosa and its submucosal structures. Pseudostratified ciliated epithelium has a covering layer of mucus produced by goblet cells and bronchial glands) and the fluid that contains various proteins including immunoglobulins and secretory components. A few cells present on the surface include lymphocytes (from BALT) and macrophages. Among the epithelial cells are absorptive brush cells with microvilli and dendritic cells. (B) An enlargement of the alveolar unit illustrating the components of the host defences active on the alveolar surfaces. If a bacterium B has escaped the aerodynamic filtration defences of the upper respiratory tract (URT), a number of immune mechanisms are activated. AM: Alveolar macrophage, PMN: Peripheral mononuclear leukocytes, T LYM: T-Lymphocytes, B LYM: B-Lymphocyte (Reynolds, 1991).

In the upper airways, lymphoid tissue is in the naso-oropharynx and the Waldeyer's tonsillar ring. More diffusely distributed bronchus-associated lymphoid tissue (BALT) is found in the trachea and bronchi. The BALT seems to be strategically located at the branching points of the conducting airways where it might intercept the antigens, derived from the invading organisms, that might impact.

Cells in BALT are mainly lymphocytes scattered reticulum cells and occasional macrophages (that are similar to dendritic and interdigitating macrophages). Submucosal lymphoid tissue is present along the airways in the transition area of the terminal bronchioles in the form of cellular aggregates or nodules, which bulge into air spaces, and as individual lymphocytes and plasma cells. A variety of cells are capable of acting as antigen-presenting cells (APCs) and acting as accessory cells for activation antigen-specific T-cells. These include alveolar macrophages and dendritic cells.

Host defence mechanisms change dramatically as mucocilliary clearance, cough and secretory immunoglobulins give way to macrophages, inflammatory cells, surfactant and opsonins. In the alveolar milieu at least four interactions could occur: *1)* the particulate matter becomes coated with opsonins contained in the epithelial lining fluid (ELF) that enhance phagocytosis by macrophages; *2)* the macrophages, activated by cytokines, enhance their bacteriostatic and bacteriocidal function; *3)* the macrophages can process the particulates, and if antigenic, present it to appropriate lymphocytes which will generate an immune response; and *4)* an inflammatory reaction can be initiated. These interactions and consequences require interplay between various cellular and acellular components of the alveolar

defence system. The acellular lavage fluid contains an array of lipoproteins, proteins and enzymes. Pertinent for the immunologic responses is the effector molecules including immunoglobulins (predominantly IgG), surfactant proteins, fibronectin fragments and C-reactive proteins, and complement proteins. The cellular immunity in the alveolar space involves macrophages and various T-lymphocytes that have access to them.

1.10.2 COMPONENTS OF THE SURFACTANT

Pulmonary surfactant is a complex mixture of neutral lipids, proteins and carbohydrates, which lines the alveolar epithelium at the air-liquid interface. Surfactant recovered from bronchoalveolar lavage is composed of 85-90% lipids, about 10% proteins and 2% carbohydrates (*King and Clements, 1972*).

1.10.2.1 LIPIDS

The majority (80-90%) of the surfactant lipids is composed of phospholipids, whereas cholesterol comprises the largest amount of the neutral lipid (*Harlan et al., 1966*). Phosphatidylcholine (PC) makes up 70-80% of the surfactant phospholipids, ~60% of which is disaturated fatty acyl, dipalmitoylphosphatidylcholine (DPPC) (*Veldhuizen et al., 1998*). The second major phospholipid in phosphotidyl glycerol (PG) (*Hallman and Gluck, 1975*). The minor components of the surfactant phospholipid include phosphatidylinositol (PI), phosphatidylethanolamine (PE) and phosphatidylserine (PE) (*Body, 1971*). DPPC is the main surface-active component of surfactant and is responsible for reducing surface tension at the alveolar surface to values <10mN/m at end expiration. The

other lipid constituents may aid in rapid absorption and respreading of surfactant at the air-liquid interface (*Van Golde et al.*, 1988).

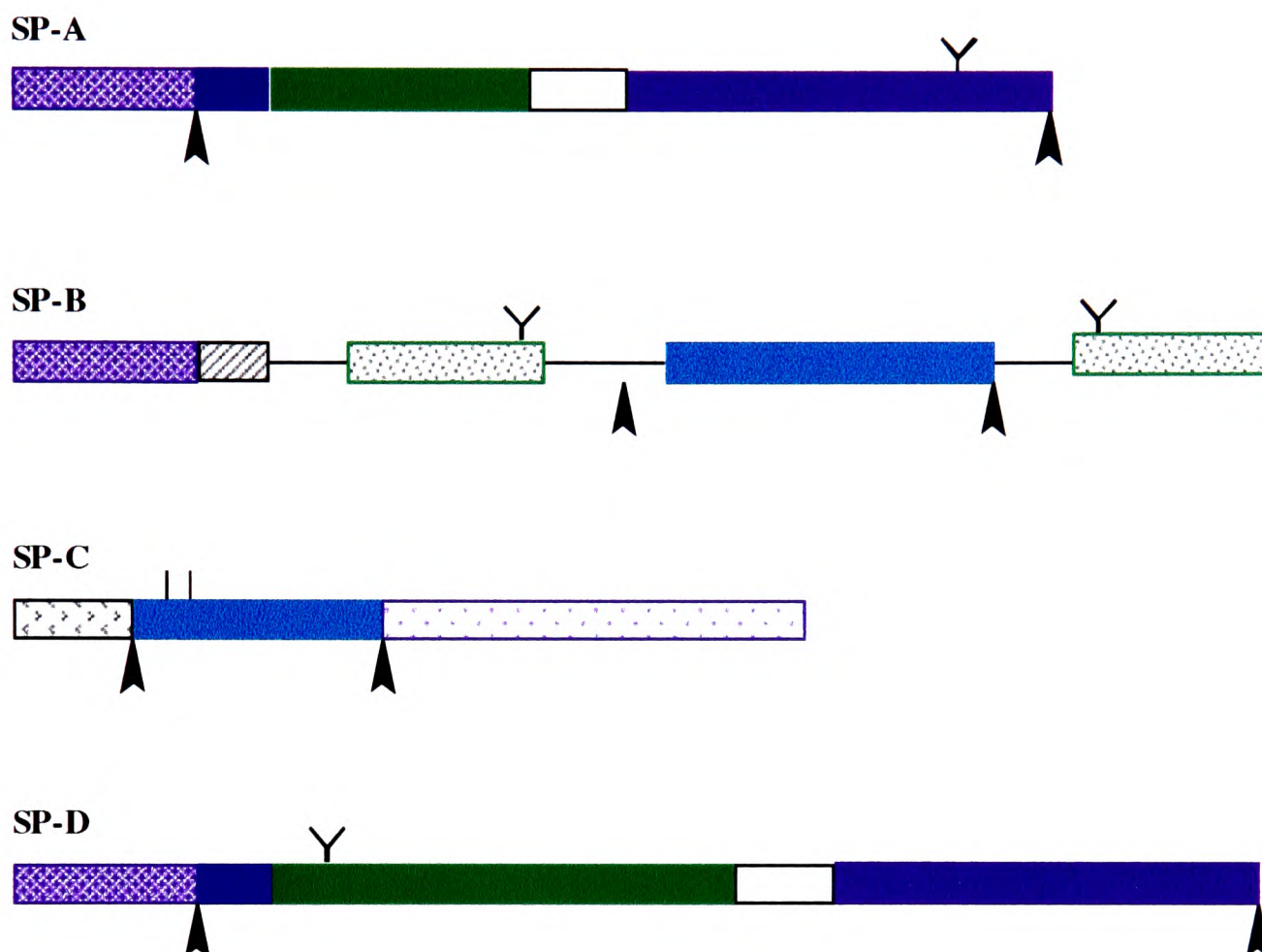

Figure 1-11: Schematic linear representation of the domain structure of the surfactant protein monomers.

SP-A: the blue shaded region represents the signal peptide followed by N-terminal region. The solid green region depicts the collagenous region, the Y represents the N-linked glycosylation on the carbohydrate-recognition domain represented by the solid blue shading. The collagenous region is linked to the CRD via an amphipathic α -helical coil. **SP-B:** the preprotein is shown organised into four domains based on the distribution of the cysteine residues. the 49 amino acid form of SP-B associated with the extracellular surfactant is depicted in light blue shading. **SP-C:** The preprotein containing the 35 residue of the fully processed SP-C is shown in light blue shading along with the flanking regions. The palmitic acids linked to the two adjacent cysteine residues in the N-terminal region are indicated by |. **SP-D:** the 43-kDa monomer of the mature protein, with organisational similarity to SP-A.

1.10.2.2 SURFACTANT APOPROTEINS

Four surfactant proteins (*Possmayer*, 1988) have been described; SP-B and SP-C, which are proteolipids and the relatively hydrophilic: surfactant protein-

A (SP-A) and -D (SP-D) (Figure 1-11). SP-A and SP-D show structural similarity to complement component C1q and members of the collectin family, and have been shown to play a role in the innate immune mechanisms.

1.10.3 SURFACTANT METABOLISM

Secretion is a critically regulated event in the dynamic metabolism of the surfactant. Surfactant is secreted from type-II cells by the exocytosis of lamellar bodies. Under resting conditions about 10% of the intracellular pool of surfactant is secreted per hour. The secretion and re-utilisation cycle of surface-active material involves a number of complex regulated processes (Figure 1-12) that include: (1) synthesis; (2) intracellular transport; (3) sorting and packaging in the lamellar bodies; (4) translocation of the lamellar bodies to the apical plasma membrane of the type-II cells; (5) exocytosis; (6) absorption to the air-liquid interface; (7) physical separation of the surfactant components during compression at the air-liquid interface; (8) uptake of extracellular surfactant; (9) intracellular processing of recycled surfactant components from alveolar fluid (which differs from the processing of the newly synthesised components); and finally (10) secretion of the recycled material.

Secretion of the phospholipids on the surface-active material is solely by alveolar type-II cells and this intracellular surfactant is stored in lamellar bodies. However, secretion and trafficking of the surfactant proteins are more complex. SP-A may be secreted by routes independent of lamellar bodies in type-II cells and is also synthesised by other cell types. SP-A, SP-B and SP-D are produced by both type-II cells and non-ciliated Clara cells. There are two different ways of

stimulating secretion in the intact lung. One is by hyperventilation and the other is by action of an agonist that directly stimulates type-II cells. Such agonists include: Tetradecanoyl phorbol acetate (TPA), diacylglycerol, ATP, β -adrenergic agonists, calcium ionophores, arachidonate metabolites, etc. These factors are summarised in Table 1-5.

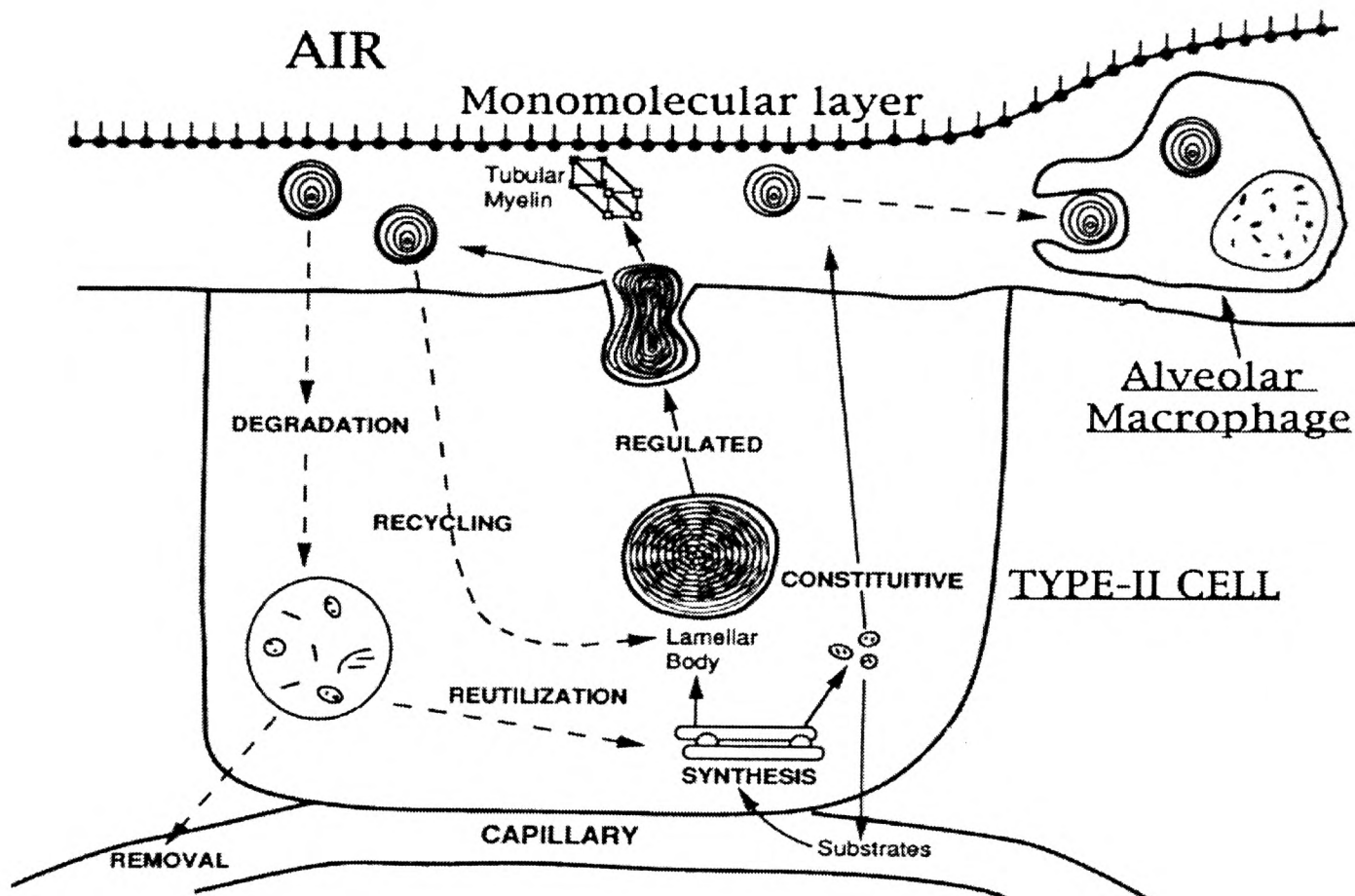

Figure 1-12: Schematic representation of a hypothetical scheme of the metabolic pathways of surfactant secretion uptake, clearance and reutilization (Wright, 1997).

Surfactant secreted into the ELF undergoes a series of dramatic structural rearrangements (Kuroki *et al.*, 1988). Once lamellar bodies are exocytosed from the type-II cells the lamellar bodies unravel spontaneously in the hypophase to form large ordered tubular myelin and loose lipid arrays (multivesicular liposomes, large aggregate forms and heavy surfactant) (Gross *et al.*, 1997). The tubular myelin and

loose arrays provide the lipids that adsorb onto the air-fluid interface to form the surface film.

Table 1-5: Factors that affect the secretion and clearance of surfactant.

FACTOR	SECRETION	CLEARANCE
Deep inflation/hyperventilation	↑	↑
β-adrenergic stimuli (isoproterenol>epinephrine>norepinephrine)	↑	↑
SP-A	↓	↑
Purinergetic stimuli (ATP>ADP>AMP)	↑	?
Calcium ionophores (A23187/ionomycin)	↑	?
Activators of protein Kinase-C (Tetradecanoyl phorbol acetate {TPA})	↑	?
Alkalosis	↑	?
Lipid mediators: arachidonate, PGE ₂ , LTE ₄	↑	?
Histamine	↑	?
Vasopressin	↑	?
Endothelin	↑	?
Serum lipoproteins	↑	?
SP-B, -C, -D	?	↑

The surfactant system is in a state of continuous flux. The intra-alveolar pool of surfactant lipids has a turnover of approximately every 5-10 hrs (*Wright and Clements, 1987*). Some surfactant phospholipids are degraded during the clearance process and the constituents are incorporated into the newly synthesised lipids. Possible sites of degradation include type-II cell, alveolar macrophage and the liquid hypophase that covers the alveolar epithelium.

1.11 SURFACTANT PROTEIN-A

Surfactant protein-A (SP-A), initially called SP-35, was identified as a 32-38-kDa (reduced) protein in surfactant purified from lavage fluid by King and

Clements (*King and Clements, 1972; King and Clements, 1972; King and Clements, 1972*). SP-A has been found in every vertebrate species. Initial studies had been focussed on its role in surfactant structure and function, but there are increasing evidence on its role in pulmonary host defence. SP-A makes up approximately 50% of total protein in isolated surfactant but only 1% of total protein in the lamellar bodies (*Oosterlaken-Dijksterhuis et al., 1991*), other proteins being predominantly SP-B and -C.

There are two transcribed genes for human SP-A on the long arm of chromosome 10 which encode isoforms with different residues at 7 of the 248 positions (*Floros et al., 1986; Bruns et al., 1987*).

1.11.1 TISSUE DISTRIBUTION

SP-A mRNA is expressed in epithelial cells of the distal airspaces, including alveolar type-II cells and the non-ciliated bronchiolar cells (Clara cells) of the terminal bronchioles and conducting airways (*Khoor et al., 1993*). SP-A mRNA is also found in the serous glands of the proximal human trachea (*Khoor et al., 1993*) (*Phelps and Floros, 1988*). Western blot analyses have suggested the presence of SP-A in rat intestinal epithelium (*Rubio et al., 1995*), human and rat mesentery (*Chailley-Heu et al., 1997; Eliakim et al., 1997*) and human inner ear (*Yamanaka et al., 1991*), although the precise identity of the immunoreactive protein has not been determined.

1.11.2 STRUCTURE

Comparison of the cDNAs of SP-A isolated from different species reveal extensive similarities in the sequence (*Benson et al., 1985; White et al., 1985; Sano*

et al., 1987; *Boggaram et al.*, 1988; *Korfhagen et al.*, 1992; *Yuan et al.*, 1997). The deduced primary structure is characterised by four well-defined structural domains: a short N-terminal segment containing interchain disulphide bonds, a collagen-like region consisting of 23 (human, baboon) or 24 (rat, rabbit, guinea pig) Gly-Xaa-Yaa repeats, a hydrophobic 'neck' domain and a carbohydrate recognition domain (CRD). The lectin domain shows high similarity with other members of the collectin family, especially with MBL-A (*Drickamer et al.*, 1986). The trimeric units are laterally bound by strong hydrophobic (Van der Waals) forces and charged interactions through the first half of the collagen-like region and stabilised by inter- and intra-trimeric disulphide bonds at the N-terminus (*Voss et al.*, 1988).

Purified SP-A migrates heterogeneously on SDS-PAGE under reducing conditions (*Weaver et al.*, 1985), due to the variable glycosylation with sialic-acid containing oligosaccharide at one or two potential N-linked glycosylation sites (*Weaver et al.*, 1985; *Whitsett et al.*, 1985). Under non-reducing conditions, the protein appears as a ladder of disulphide-linked multimers composed of up to six or more subunits (*Hawgood et al.*, 1985). The apparent molecular mass of SP-A in solution is reported to be 650kDA by gel-filtration analysis and sedimentation equilibrium studies (*King et al.*, 1989) indicating association of six trimers. Under the electron microscope, SP-A has a highly ordered structure resembling a bouquet of tulips (Figure 1-6) (*Voss et al.*, 1988).

1.11.3 PROPERTIES

The carbohydrate recognition domain mediates the selective recognition of pathogenic organisms and the binding to several soluble and membrane associated ligands (Table 1-6).

The monosaccharide specificity of SP-A obtained from the competitive inhibition of SP-A binding to mannan follow the rank order: N-acetylmannosamine>L-fucose, maltose>glucose>mannose (*Drickamer et al.*, 1986; *Haagsman et al.*, 1987).

1.11.4 PHYSIOLOGICAL ROLES (SURFACTANT)

Surfactant Protein-A is primarily associated with lipids and plays a role in surfactant homeostasis. SP-A is required for the structure and/or stability of surfactant aggregates. Tubular myelin (TM) contains large amounts of SP-A (Figure 1-15) and is essential for its formation in the extracellular space in the alveoli as the lamellar bodies unravel (*Suzuki et al.*, 1989; *Veldhuizen et al.*, 1996). SP-A knockout mice have little or no TM (*Korfhagen et al.*, 1996). LBs appear to interact with the secreted SP-A and calcium to form TM, which contains membranes as square lattices in cross-sections (*Voorhout et al.*, 1991; *Young et al.*, 1992) and tubules in longitudinal sections (*Williams*, 1978). SP-A appears to be located near the corners of the square membrane lattices of TM (*Williams*, 1978; *Palaniyar et al.*, 1999; *Palaniyar et al.*, 1999). SP-A is also known to augment the adsorption of phospholipids to an air-liquid interface and improve surface tension of the cycled surfactant mixture, *in vitro* (*Hawgood et al.*, 1987).

Table 1-6: Biological ligands for SP-A

Surfactant phospholipids (King, 1984; Hawgood et al., 1985; Kuroki and Akino, 1991)
Dipalmitoylphosphatidylcholine
Phosphatidylcholine
Sphingomyelin
Pulmonary glycolipids (Childs et al., 1992; Kuroki et al., 1992; Kuroki et al., 1992)
Lactosylceramide
Galactosylceramide
Asialo-G _{M2}
Proteins
Phospholipase A ₂ (Chander et al., 1982; Fisher et al., 1994)
Major surface glycoprotein of <i>P. carinii</i> (Zimmerman et al., 1992; McCormack et al., 1997)
Outer membrane protein of <i>H. influenza</i> (McNeely and Coonrod, 1994)
Myosin (Michelis et al., 1994)
Annexin (Sohma et al., 1995)
'Putative' SP-A receptors:
210-kDa SP-R (Chronos) (Chronos et al., 1996)
32-kDa SPAR (Strayer) (Strayer, 1991; Strayer et al., 1993; Strayer et al., 1996)
126-kDa C1qRp (Nepomuceno) (Nepomuceno et al., 1997)
53-kDa C1qR (Malhotra) (Malhotra et al., 1993)
55-kDa BP55 (Wissel, Stevens) (Stevens et al., 1995; Wissel et al., 1996)
gp340 (Tino and Wright, 1999)

1.11.5 PHYSIOLOGICAL ROLES (COLLECTIN)

SP-A has been shown to bind to a number of phagocytic cells, with differing downstream effects of that binding. SP-A binding to type-II cells and alveolar macrophages in a calcium-dependent manner is considered to be mediated by a 210-kDa receptor and then to be subsequently internalised (*Wintergerst et al.*, 1989; *Manz-Keinke et al.*, 1991; *Pison et al.*, 1992; *Ohmer-Schrock et al.*, 1993).

The binding leads to a dose-dependent increase in intracellular calcium levels, which lead to the increase in the levels of IP₃, an active intracellular signalling molecule (*Hishikawa et al.*, 1991; *Ohmer-Schrock et al.*, 1993). Another signalling pathway activated in the alveolar macrophages is the protein tyrosine phosphorylation leading to actin polymerisation, resulting in the SP-A-stimulated phagocytosis (*Schagat et al.*, 1999). Various physiological functions attributed to the various domains of SP-A have been summarised in [Figure 1-13](#).

Hartshorn *et al* demonstrated that SP-A binds influenza A virus and inhibits haemagglutination (*Hartshorn et al.*, 1997). SP-A can bind to the virus-infected cells (*Benne et al.*, 1995), and this binding can be inhibited by the removal of N-linked carbohydrate or the terminal sialic acid from the SP-A. The removal of this oligosaccharide also abrogated the binding of SP-A to herpes simplex virus type-I infected cells (*van Iwaarden et al.*, 1991; *van Iwaarden et al.*, 1992). SP-A has been shown to stimulate the phagocytosis of serum-opsonised and unopsonised *Staphylococcus aureus* (logarithmic growth phase of organism) (*van Iwaarden et al.*, 1990), (*Manz-Keinke et al.*, 1992). SP-A binds to the lipid A moiety of the LPS of the gram-negative bacteria and enhance phagocytosis and bacterial killing of *Streptococcus pneumoniae*, *Haemophilus influenzae*, *Pseudomonas aeruginosa* (*Tino and Wright*, 1996), *Klebsiella pneumoniae* (*Kabha et al.*, 1997) and some species of *Salmonella*.

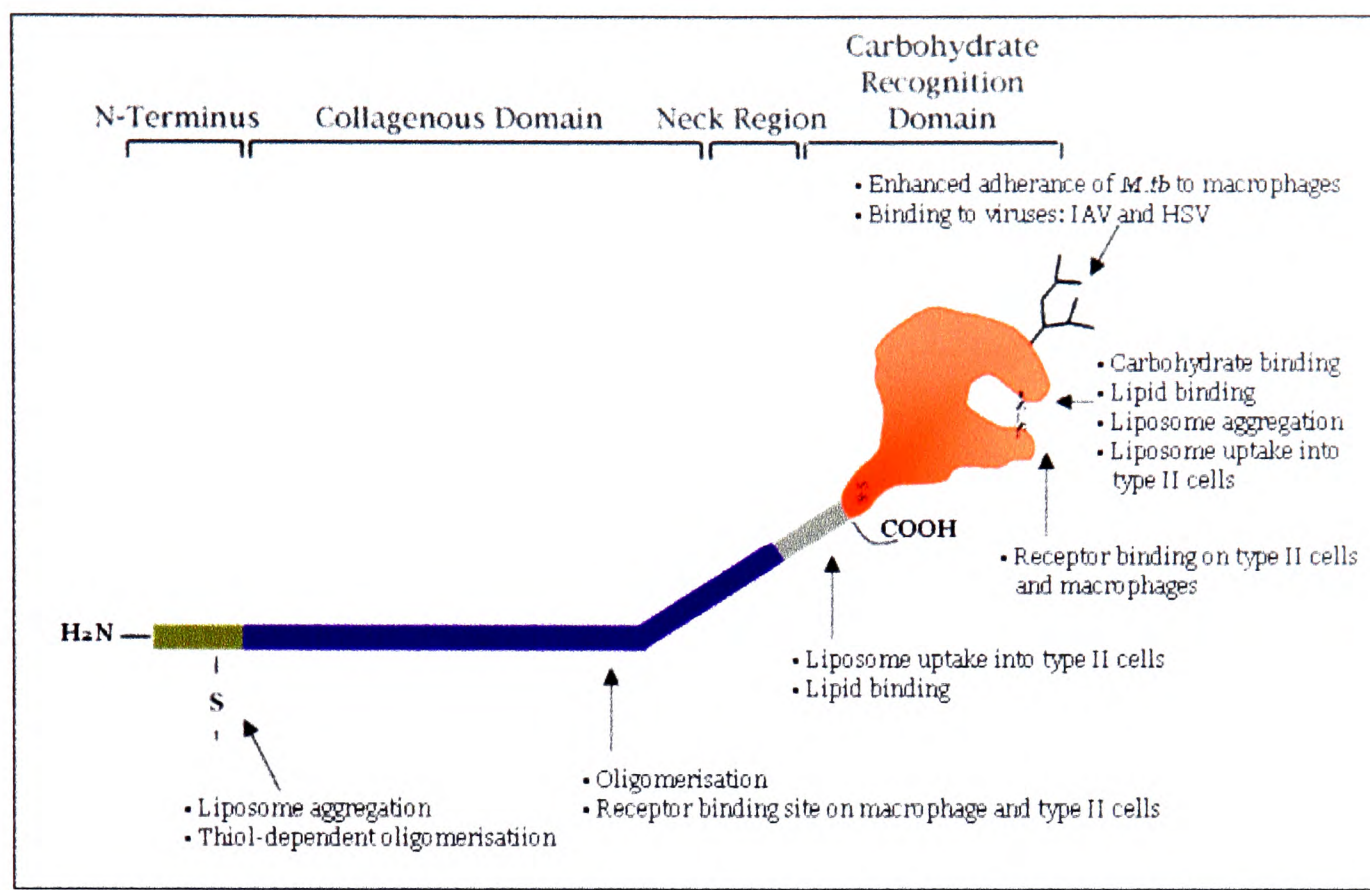

Figure 1-13: Structural organisation and summary of the functional properties attributed to various domains of the Lung Surfactant-A.

SP-A isolated from patients with alveolar proteinosis enhanced the adherence and phagocytosis of *Mycobacterium tuberculosis* by macrophages and this effect is attributed to the oligosaccharide moiety of the SP-A and macrophages (Gaynor *et al.*, 1995). SP-A also shows calcium-dependent binding to and enhanced phagocytosis of acapsular *Cryptococcus neoformans* (Schelenz *et al.*, 1995), *Candida albicans* (Rosseau *et al.*, 1997) and the conidia of *Aspergillus fumigatus* (Madan *et al.*, 1997). SP-A binds in a calcium-dependent manner to glycoproteinA (gp120) of *Pneumocystis carinii* and enhances adherence to, but not phagocytosis by macrophages (Zimmerman *et al.*, 1992).

SP-A also stimulates the production of several important mediators of inflammation and immune defence by type-II and alveolar macrophages, including cytokines: tumour necrosis factor (TNF- α) and colony stimulating factors (CSFs)

as well as reactive species of oxygen and nitrogen (*Blau et al.*, 1994). Recent evidence indicates the ability of SP-A to inhibit T-cell proliferation *in vitro* via its 210-kDa receptor (*Borron et al.*, 1998; *Borron et al.*, 1998).

1.11.6 SP-A NULL MOUSE MODEL

The SP-A knockout mouse has only marginal defects in the surfactant homeostasis and respiratory function (*Ikegami et al.*, 1997). Although pulmonary function in SP-A(-/-) mice is unaltered under normal conditions, distinct structural and functional properties of SP-A-deficient surfactant were noted *in vitro* (*Ikegami et al.*, 1998) (Figure 1-14). SP-A-deficient surfactant lacks tubular myelin, is more easily inhibited by plasma protein, and forms less dense lipid aggregates.

However, the SP-A null mice showed enhanced susceptibility to pathogens *viz.* *Pseudomonas aeruginosa* (*LeVine et al.*, 1998), RSV (*LeVine et al.*, 1999) (*Harrod et al.*, 1999), *Mycobacterium pulmonis* (*Hickman-Davis et al.*, 1999) and Group B *Streptococci* (*LeVine et al.*, 1997), the infectious agents studied so far. The type of immune response mounted was dependent upon the type of microorganisms. Susceptibility to infections could be countered by administering exogenous SP-A along with the infectious agent (*LeVine et al.*, 1999; *Borron et al.*, 2000).

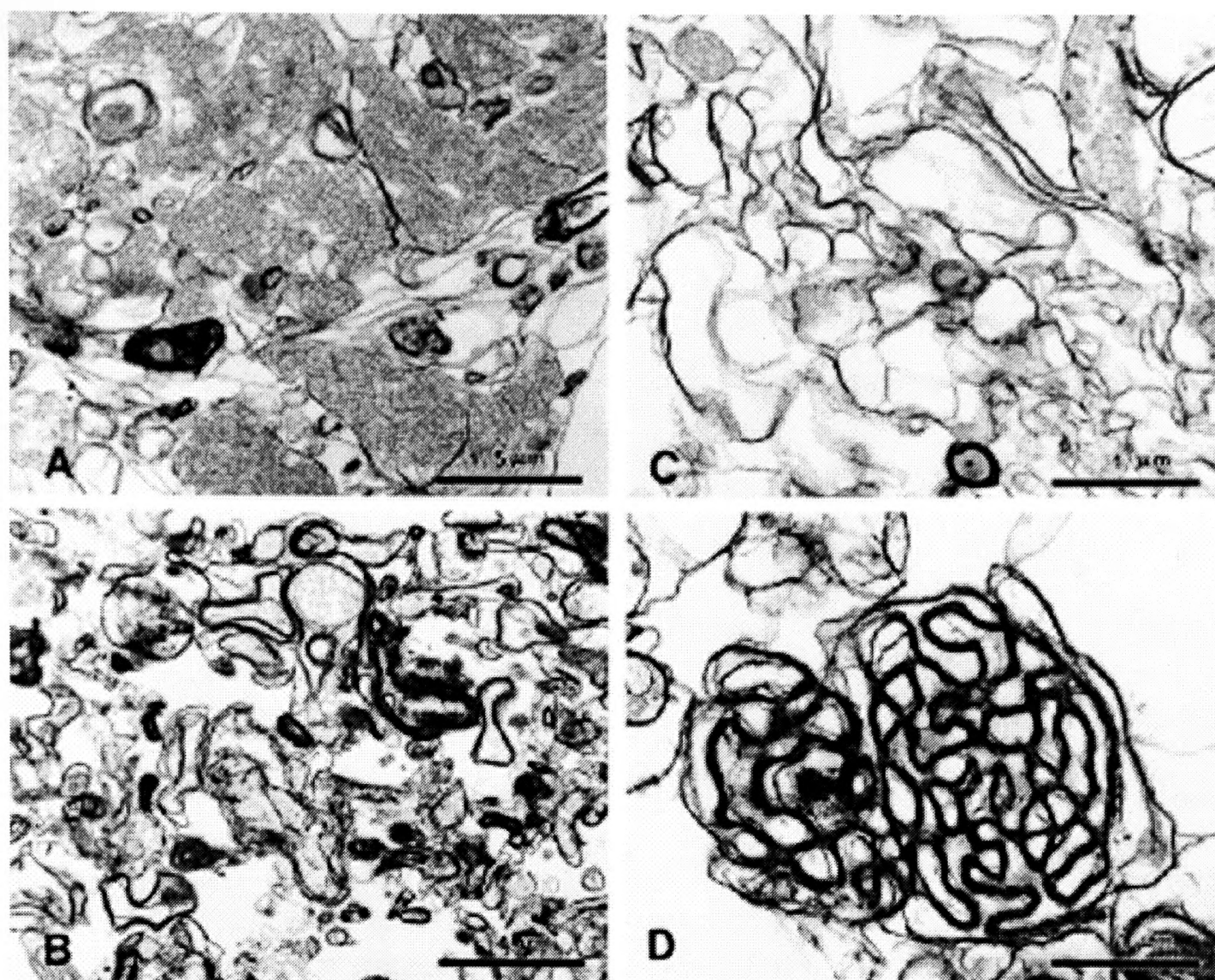

Figure 1-14: Morphology of large aggregate (LA) surfactant of the SP-A knockout mice as seen under electron microscope.

(A) LA pellets from alveolar washes of wild type or SP-A(+/+) mice showing normal tubular myelin (TM). (B) Surfactant pellet from null or SP-A(-/-) mice contained no TM. (C) Lower magnification of surfactant from SPA(-/-) mice demonstrating large area of loose lipid arrays. (D) Large cords of densely packed lipid arrays were also frequently found in surfactant pellets from SP-A(-/-) which do not exist in surfactant pellet obtained from SP-A(+/+) mice. (Ikegami *et al.*, 1998).

1.12 SURFACTANT PROTEIN-B

Surfactant protein-B (SP-B) is a small homodimeric protein that is found tightly associated with surfactant lipids in the alveolar space. SP-B isolated from the lung lavage is a 79 amino acid homodimer of approximately 18 kDa (Hawgood *et al.*, 1987). The SP-B gene is first transcribed/translated into a significantly larger monomeric 42 kDa preproprotein of 381 amino acid residues. The 23 amino acid

N-terminal signal peptide mediates the translocation of SP-B into the lumen of ER where is subsequently cleaved. The proprotein is N-glycosylated on regions flanking the mature SP-B sequence, that are cleaved in at least two steps (*O'Reilly et al.*, 1989; *Weaver and Whitsett*, 1989) (*Weaver et al.*, 1992). Proteolytic processing of the proproteins occur in the acidic compartments distal to the Golgi complex where the mature SP-B is generated by sequential cleavage of the N-terminal and the C-terminal propeptides. Subsequently, the protein undergoes sulphhydryl-dependent oligomerisation and associates with the multivesicular body, promoting vesicular fusion. The multivesicular body delivers SP-B with the associated lipids to the lamellar body, the intracellular storage form of surfactant, which is then secreted into the epithelial lining fluid monolayer either constitutively or in response to agonists (*Weaver and Whitsett*, 1989) (*Weaver*, 1998).

SP-B is a necessary but not sufficient, protein for the formation of the tubular myelin (*Baatz et al.*, 1990) (*Williams et al.*, 1991) (*Suzuki et al.*, 1989). Aggregation of the lipid-bound SP-B leads to permeabilisation of the vesicular membrane, consequently releasing the contents. The dimeric nature of SP-B may allow it to bring the two lipid bilayers into close proximity (Figure 1-15) resulting in an evenly spaced ordered array of lipoprotein discs (*Williams et al.*, 1991) (*Poulain et al.*, 1992) (*Oosterlaken-Dijksterhuis et al.*, 1992). The formation/stability of the tubular myelin is dependent on the interaction of SP-B with SP-A both *in vitro* (*Suzuki et al.*, 1989; *Williams et al.*, 1991) and *in vivo* (*Clark et al.*, 1995; *Korfhagen et al.*, 1996).

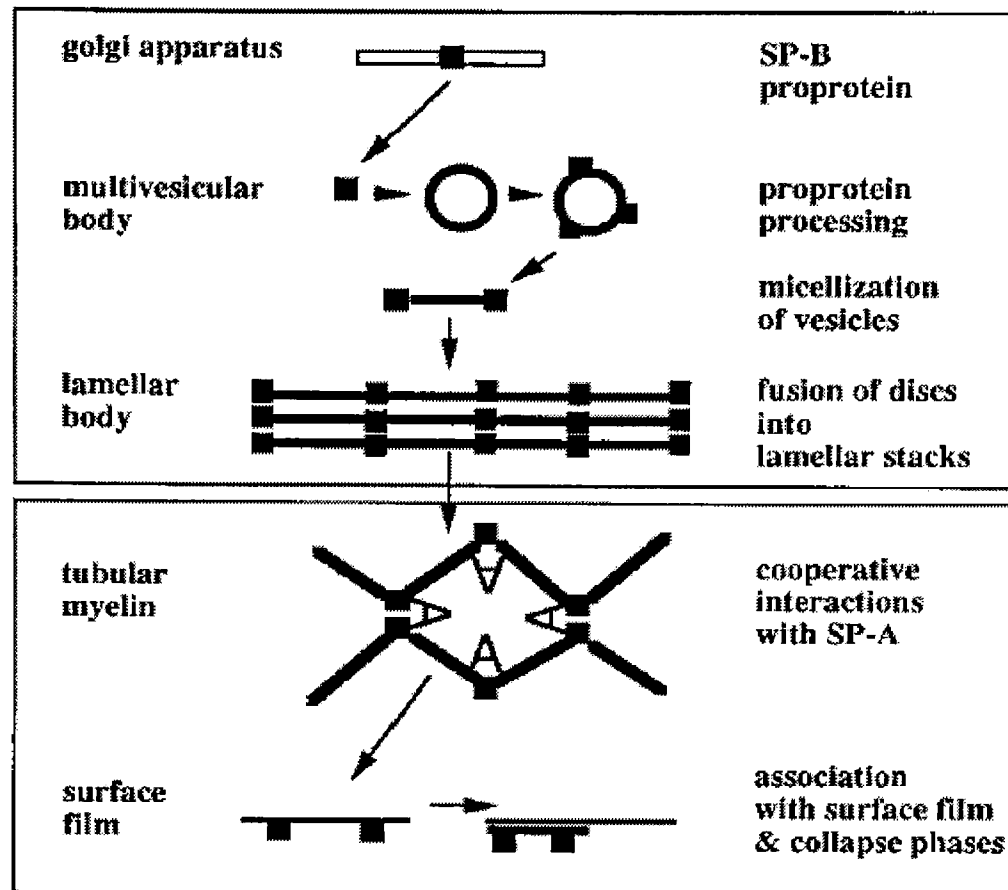

Figure 1-15: A model for the actions of SP-B on surfactant lipids.

The top panel depicts intracellular events in type-II cells and the bottom panel depicts the extracellular events. The potential sites of SP-B action are indicated to the left of the scheme. Mature SP-B is represented by solid squares. Lipid bilayers are represented by solid circles or lines and the surface monolayer as a thin line. The letter A represents SP-A in tubular myelin. (Adapted from (Hawgood *et al.*, 1998))

1.13 SURFACTANT PROTEIN-C

In most animal species, the major form of surfactant protein-C (SP-C) is a 35-residue peptide chain, which contains two thioester-linked palmitoyl groups. Besides the major 4.2-kDa isoform, several minor forms of the protein exist, formed from the N-terminal truncation, lysine palmitoylation, methionine oxidation and C-terminal oxidation. SP-C is exclusively expressed in lungs and is unique to pulmonary surfactant (Weaver and Whitsett, 1991). It is a pronouncedly hydrophobic molecule comprising of >70% non-polar residues, and the covalently linked fatty acyl chains.

SP-C is proteolytically derived from an approximately five times larger precursor, where the non SP-C regions share no similarity to the mature peptide in terms of amino acid sequence or hydrophobicity. The structure reveals a rigid α -helix with nearly ideal helix geometry which encompasses residues 9-24 (*Johansson et al.*, 1994).

SP-C is situated in the DPPC monolayer making a 70° tilt relative to the monolayer plane (*Gericke et al.*, 1997). The helix is shorter than the thickness of the gel phase phospholipid bilayers, and mismatches between the peptide length and bilayer thickness, thereby promoting phase separation of peptides and lipids (*Johansson and Curstedt*, 1997). SP-C undergoes aggregation in gel phase DPPC/PG bilayers, but is monomeric in the fluid phase (*Horowitz et al.*, 1993). Furthermore, SP-C interacts preferentially with fluid phospholipids with palmitoyl fatty acyl chains, but is excluded from the corresponding gel-phase bilayers (*Horowitz*, 1995; *Perez-Gil et al.*, 1995). It has been suggested that SP-C may act as a 'hydrophobic lever' that anchors and spreads a maximum number of phospholipid molecules (*Gericke et al.*, 1997). The palmitoyl groups are essential for the optimal surface activity: adsorption and respreading of phospholipids to an air/water interface, mechanical stability of the interfacial film, lowering of the surface tension, in conjunction with the ELF phospholipids (*Wang et al.*, 1996) (*Qanbar et al.*, 1996).

1.14 SURFACTANT PROTEIN-D

Lung Surfactant Protein-D (SP-D) was first identified by *Persson et al* as a collagen-like glycoprotein secreted by freshly isolated rat type-II cells (*Persson et*

al., 1988). It was subsequently identified in bronchoalveolar lavage (BAL) in association with crude surfactant (*Persson et al.*, 1989). It was originally designated as CP4 (collagenous protein-4). Protein and cDNA sequencing led to the identification of the C-type lectin domain; and its inclusion in the collectins (*Hawgood and Clements*, 1990).

1.14.1 BIOSYNTHESIS AND DISTRIBUTION

SP-D was originally identified in lung, secreted by alveolar type-II (*Persson et al.*, 1988) and non-ciliated bronchoalveolar cells (Clara cells) (*Crouch et al.*, 1991; *Crouch et al.*, 1992) where it is localised in granules present in the apical domain of the cell. The concentration of SP-D is approximately 800 ng/ml, as estimated from the bronchoalveolar lavage from healthy human volunteers, and is several fold lower than the concentration of SP-A (*Honda et al.*, 1995).

Although lung appear to be the major site of synthesis (*Rust et al.*, 1991; *Shimizu et al.*, 1992), SP-D is also reported to be synthesised in rat gastric epithelium (*Fisher and Mason*, 1995). Immunological cross reactivity with anti-SP-D has also indicated the presence of SP-D in tracheobronchial, lachrymal and salivary glands. It is also detectable in human serum (approximately 70 ng/ml) (*Honda et al.*, 1995). SP-D, along with SP-A, levels have been shown to be elevated in patients suffering with acute respiratory distress syndrome (ARDS), three days after the onset of the condition (*Greene et al.*, 1999; *Greene et al.*, 1999).

1.14.2 STRUCTURE

On SDS/PAGE both human and bovine SP-D behave as a single band of 44 kDa under reducing conditions and a band of 160 kDa under non-reducing conditions (*Lu et al.*, 1992). cDNA cloning has provided the complete amino acid sequences for human (*Lu et al.*, 1992), rat (*Shimizu et al.*, 1992), mouse (*Motwani et al.*, 1995) and bovine SP-D (*Lim et al.*, 1993), which shows that the 43 kDa chain contains 355 amino acid residues (349 in bSP-D). The chain comprises four regions: a short N-terminal consisting of 25 residues containing two cysteine residues, followed by an uninterrupted collagen-like sequence of 59 Gly-Xaa-Yaa repeats, a short linking domain ('neck' region) that connects the collagen domain to the 153 residue long carboxy-terminal CRD. The latter domain contains all invariant residues, including four conserved cysteine residues, characteristic of the family of Ca^{2+} -dependent C-type lectins.

Interactions between amino-terminal domains of the trimeric subunits are stabilised by interchain disulphide bonds (*Crouch et al.*, 1994). The collagen domain of SP-D is much longer than that of SP-A (59 versus 24 Gly-Xaa-Yaa). Furthermore, the collagen domain of SP-D has no kink in the triple helix resulting in a length of the collagen triple helix of about 46nm (bovine SP-D) (*Lu et al.*, 1993). Four of the trimeric subunits are linked via their N-terminal sections to yield a tetrameric 560 kDa molecule with twelve C-type lectin domains radiating outwards. When viewed under electron microscope, the 160 kDa subunit appears as a 45.8 ± 3 nm long rod. The fully extended X-shaped tetrameric SP-D has an overall span of approx. 114 nm (*Crouch et al.*, 1994).

In general, SP-D is more similar to BC ([Figure 1-9](#)), than to any other collectin. Like BC, SP-D is predominantly assembled as a dodecamer consisting of four homotrimeric subunits with relatively long triple-helical arms (*Lu et al.*, 1993; *Crouch et al.*, 1994). However, SP-D is distinguished by a slightly longer and uninterrupted collagen region that lacks cysteine residue and contains an utilised site (Asn³¹⁷) of N-linked oligosaccharides. SP-D dodecamers can self-associate to form stellate higher order multimers (up to 32 dodecamers) with peripheral arrays of trimeric CRDs (*Crouch et al.*, 1994). In contrast, conglutinin shows very little propensity for high order oligomerisation.

1.14.3 CRYSTAL STRUCTURE OF THE TRIMERIC CRD

Recently Håkansson solved the crystal structure of the trimeric CRDs (*Håkansson et al.*, 1999) ([Figure 1-16](#)). The overall fold of the trimer is similar to MBL (*Weis and Drickamer*, 1994) and tetranectin (*Nielsen et al.*, 1997). The neck region makes about eight helical turns, followed by a four-stranded β sheet. The central two β strands in this sheet are also a part of the larger, five-stranded antiparallel β sheet that dominates the structure. There are no interactions between the globular domains, but there are several contacts between the globular domain of one chain and the coiled-coil region of another.

There are three calcium ions bound to each hSP-D monomer; one at the carbohydrate-binding site and two in a second site previously described for MBL (*Weis et al.*, 1992; *Weis and Drickamer*, 1994). The cavity between the CRDs has a positively charged surface area, mainly due to Lys246, Lys252 and Lys287.

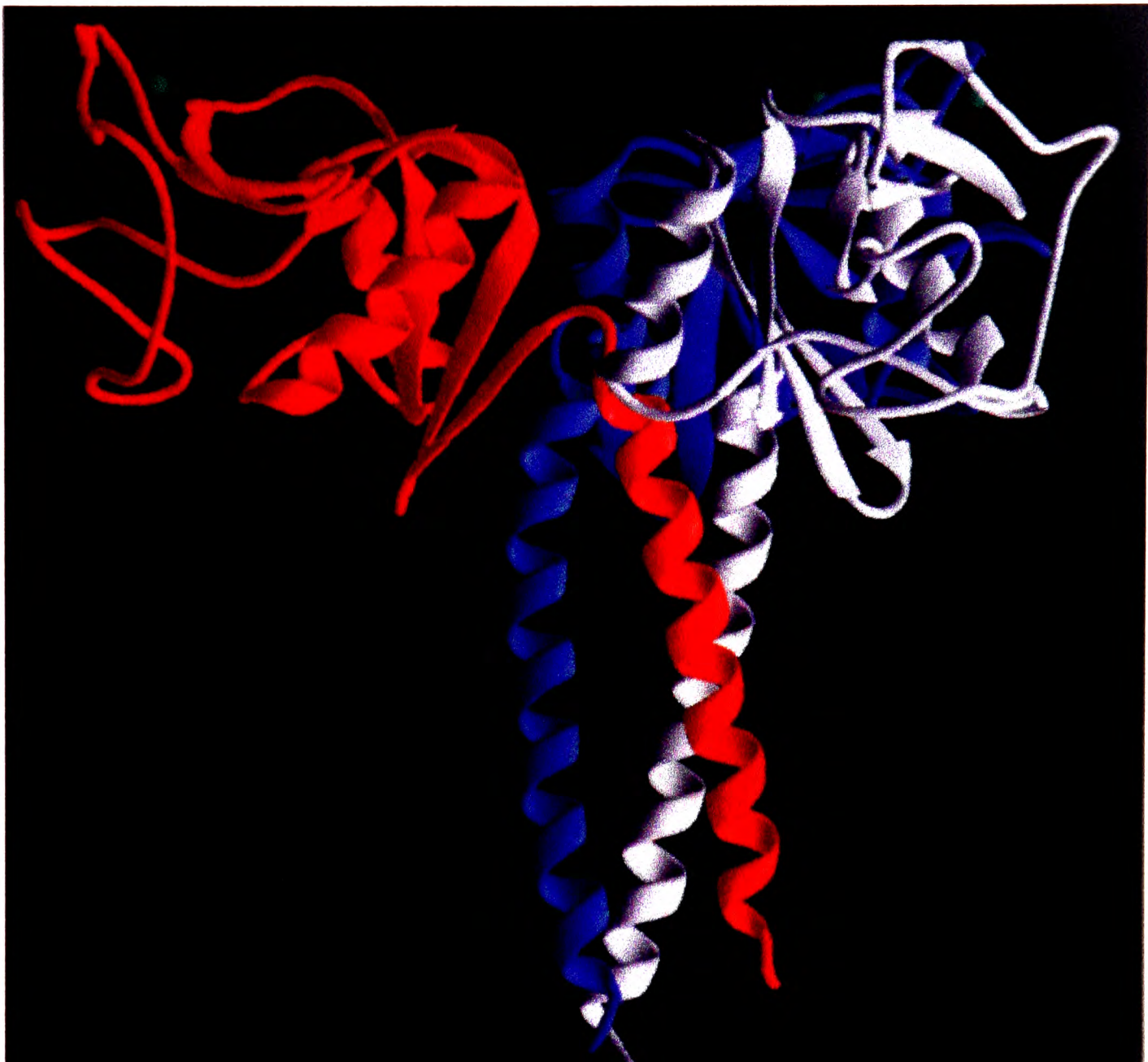

Figure 1-16: Ribbon model of the overall structure of lung Surfactant Protein-D.

Each monomer is shown in different colour and calcium ions are depicted as green spheres (*Hakansson et al., 1999*). There are three calcium ions bound to each SP-D monomer; one at the carbohydrate-binding site and the other two in a second site previously described in MBL.

The structure shows two significant deviations from the threefold, non-crystallographic symmetry. The CRD of one of the chains (chain A) was more inclined towards the coiled coil than the other chains. This deviation is linked to the placement of the Tyr228 side chain of the chain C. The corresponding Tyr 228 side chains of the chain A and B are swung out to hydrogen bond with water

molecules and to Lys229 (in the case of chain A) of the adjacent chain, whereas the tyrosine of chain C is deeply buried at the centre of the coiled coil.

1.14.4 FUNCTIONAL PROPERTIES

SP-D had been previously demonstrated to be involved, primarily, in the first line defence against inhaled pathogens rather than in surfactant metabolism. The recent evidence from the null mouse models has shown the importance of SP-D in maintaining the structural integrity of the alveolar epithelium. SP-D shows a preferential affinity for non-reducing glucopyranosides with α -anomeric configuration (*Persson et al.*, 1990) particularly, maltose with dissociation constant approaching 2mM. However, binding to a polyvalent ligand such as maltosyl₃₀-BSA revealed a greatly enhanced binding affinity, which can be attributed to the interaction of the multivalent lectin with the multivalent neo-glycoprotein. SP-D binding to maltosyl-BSA is most effectively competed with maltose, maltotriose, isomaltose and glucose (*Persson et al.*, 1990). The recombinant constructs with deletion of the N-terminal and collagen-like regions have been shown to retain their sugar specificity, albeit lower than that of the native molecules (*Lim et al.*, 1994).

1.14.5 INTERACTIONS WITH MICROORGANISMS

Surfactant protein-D is considered to play an important role in innate immunity in the lungs, via its multiple carbohydrate recognition domains. Several of the biochemical features of SP-D appear to confer distinctive functional properties as compared to other collectins. These biochemical attributes include: increased solubility in the aqueous phase of pulmonary lavage as compared to SP-

A, a collagen domain which is considerably longer than MBL and SP-A and a tendency to form high order oligomers. The quaternary structure of SP-D is ideal for aggregation and agglutination of microorganisms. The molecule consists of four globular carbohydrate-binding heads each connected to 46nm long rods, which are associated via the free ends. Thus, the molecule spans a long distance of 114 nm, a feature that may be important for the agglutination of the microorganisms.

SP-D binds both influenza A and herpes simplex viruses (*Hartshorn et al.*, 1994; *Hartshorn et al.*, 1996). It is a potent inhibitor of the red cell hemagglutination (HA) activity of various strains of Influenza A virus (IAV) (*Hartshorn et al.*, 1994) and is abrogated in the presence of EDTA or maltose. Higher orders of multimers showed enhanced HA inhibitory potential and are also responsible for its ability to aggregate IAV particles (*Hartshorn et al.*, 1994). SP-D also decreased the virus-induced inhibition of the respiratory burst by neutrophils (*Hartshorn et al.*, 1994).

SP-D binds both gram-negative and gram-positive bacteria. Core sugars of the bacterial capsular lipopolysaccharides (LPS) have been identified as the major ligand for SP-D on various gram-negative bacteria including *E. coli*, *E. aerogenes*, *Pseudomonas sp.*, *Salmonella paratyphi* and *Klebsiella pneumoniae* (*Kuan et al.*, 1992; *Lim et al.*, 1994). Since the core domain of the LPS is relatively conserved, binding of SP-D to this domain would be in line with a role for SP-D in first line host defence. The intra-tracheal instillation of LPS and hyperoxia (85% oxygen exposure) in rat caused an increase in the protein levels of SP-D and SP-A indicating their roles as lung-specific acute- response factors (*McIntosh et al.*, 1996).

SP-D has been shown to agglutinate important gastrointestinal bacteria including *Helicobacter pylori*, *Shigella* sp. and *Vibrio cholerae* - but not enterohaemorrhagic *E. coli* (Hartshorn *et al.*, 1994).

SP-D binds to acapsular *Cryptococcus neoformans* but not the encapsulated *Cryptococci* (Schelenz *et al.*, 1995). SP-D binds to gpA (gp120), a mannose and glucose rich glycoprotein, expressed on the surfaces of *Pneumocystis carinii* cysts and trophozoites, mediated via lectin-dependent interactions (Limper *et al.*, 1994; Fisher and Mason, 1995). The binding enhances the adherence of the organism to the macrophages, but do not enhance the phagocytosis by them (O'Riordan *et al.*, 1995). Immunofluorescence studies have demonstrated lectin-dependent interaction with fungal pathogens including *Histoplasma capsulatum* and *Blastomyces dermatitides* (Kuan *et al.*, 1994).

Madan *et al* reported SP-D bound to *Aspergillus fumigatus* conidia and enhanced their phagocytosis and killing by human neutrophils and alveolar macrophages (Madan *et al.*, 1997). The binding to *Aspergillus* spores is calcium-dependent and inhibited by maltose. SP-D is able to inhibit specific IgE binding to the allergens and can also block allergen-induced histamine release from allergic patients' basophils (Madan *et al.*, 1997). SP-D has been shown to bind to whole mite extract and purified native *Der p1* in a carbohydrate-specific and calcium-dependent manner (Wang *et al.*, 1996). Furthermore, SP-D has been shown to inhibit allergen-specific IgE from binding to whole mite extract. This inhibition of binding appears to be functionally significant since SP-D has also been found to inhibit histamine release from allergic patients' basophils in the presence of the surfactant (Wang *et al.*, 1998).

1.14.6 INTERACTIONS WITH IMMUNE CELLS

One of the possible functions of SP-D binding to bacteria and other microorganisms may be their presentation to phagocytic cells. Van Iwaarden reported that rat SP-D enhances the oxygen radical production by alveolar macrophages but not by peritoneal macrophages (*Van Iwaarden et al.*, 1992). The binding to the macrophages was inhibited by EDTA and maltose, glucose or mannose, suggesting a lectin-like interaction (*Kuan et al.*, 1994). These interactions may be mediated by recognising a distinct set of receptors or binding proteins on the macrophages (*Pison et al.*, 1994; *Eggleton et al.*, 1995) or by attaching to cell surface carbohydrates (*Kuan et al.*, 1994).

A receptor for SP-D has been identified on the surface of and within the alveolar and other tissue macrophages, gp-340 (*Holmskov et al.*, 1997), which would mediate the interaction between the SP-D and the macrophages. RT-PCR analysis indicate the main sites of synthesis of gp-340 are lung, trachea, salivary gland, small intestine, and stomach (*Holmskov et al.*, 1999). In some macrophages, SP-D and gp-340 were located in the same cellular compartment. Immunoreactive gp-340 was also found in epithelial cells of the small intestine and in the ducts of salivary glands. The distribution of gp-340 in macrophages is compatible with a role as an opsonin receptor for SP-D (*Holmskov et al.*, 1999).

SP-D is also a potent chemoattractant (and a haptotactic agent) for monocytes and neutrophils (*Crouch et al.*, 1993). Recombinant SP-D, comprising of the neck and the CRD, has been shown to elicit chemotactic response in human PMNs (*Cai et al.*, 1999). SP-D has also been shown to induce a directional actin-

based response in alveolar macrophages and not in peritoneal macrophages (*Tino and Wright, 1999*). The ability of SP-D to function as a chemoattractant suggests it could play a role in accumulation of inflammatory cells in lung injury. Another function of SP-D may be to scavenge free LPS (endotoxin). This would prevent LPS from binding to granulocytes and would consequently protect against septic shock.

1.14.7 SP-D NULL MOUSE MODEL

SP-D deficient mice have striking abnormalities in surfactant homeostasis and alveolar cell morphology (*Botas et al., 1998*). A progressive accumulation of surfactant lipids and apoproteins in alveolar space, hyperplasia of type-II cells with massive enlargement of intracellular lamellar bodies and accumulation of foamy alveolar macrophages were also observed (Figure 1-17). These observations are in apparent contradiction with the pre-existing results which had not shown any significant role of SP-D in surfactant homeostasis (*Persson et al., 1989*) and type-II cell function (*Kuroki et al., 1991*). However, the surfactant isolated from the lavage obtained from the null mouse performed like that from the wild type, indicating normal surfactant activity. These results may not exclude a surfactant-specific role for SP-D, and are suggestive of a role in the cell signalling that would normally maintain the appropriate alveolar surfactant pool.

Targeted ablation of SP-D gene has also been shown to cause in chronic inflammation, emphysema and fibrosis in the lungs of the SP-D(-/-) mice (*Wert et al., 2000*). Inflammation consisted of hypertrophic alveolar macrophages and peribronchiolar perivascular monocytic infiltrates. These abnormalities were found

to be associated with increased activity of matrix metalloproteinases, MMP2 and MMP9.

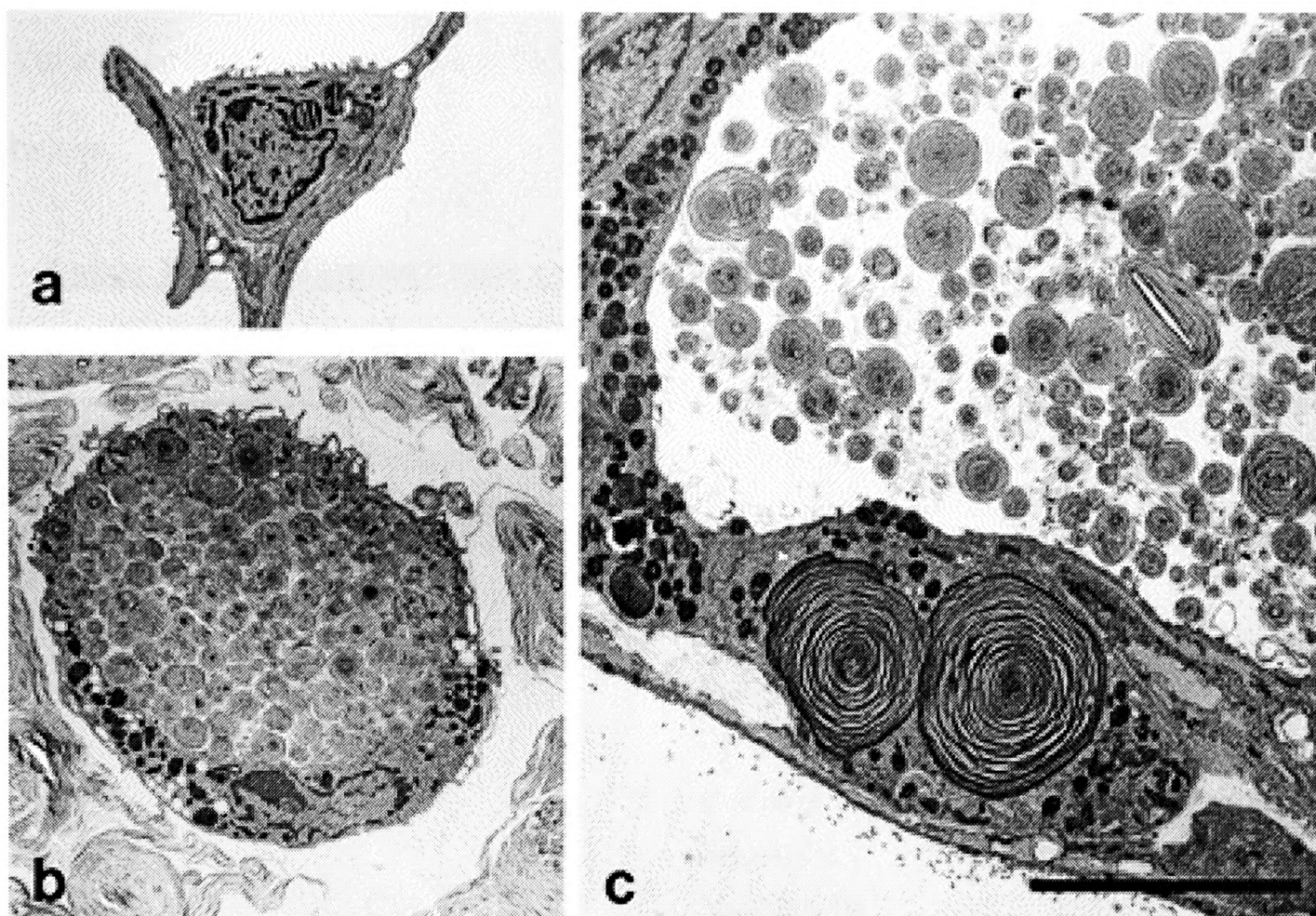

Figure 1-17: Electron micrograph of an alveolar region highlighting the structural changes as observed in the lung Surfactant Protein-D null mouse. (a) Wild-type littermate of the knockout mouse showing normal alveolar epithelial morphology, (b) massive accumulation of intra-alveolar surfactant and giant lamellar bodies, and (c) stuffed macrophage (*Botas et al., 1998*).

1.15 COLLECTIN RECEPTORS

The specificity of the interaction with the microbe is determined by the CRD of the collectins. The collectins have been shown to enhance phagocytosis *in vitro* and the clearance of selective but numerous microbes (*Kuhlman et al., 1989; Tino and Wright, 1996; Hartshorn et al., 1998*). This enhancement in uptake may partly be due to induced aggregation of the microbial particles, owing to the multiple recognition sites on the collectins, thereby facilitating the direct

recognition and subsequent uptake of the aggregated particles by the phagocytes. The enhancement of phagocytosis may also be due to the cross-linking of specific cell-surface receptors by target-bound soluble defence collagens (collectins). Various collectin receptors and binding protein have been summarised in Table 1-7 below.

Table 1-7: Transmembrane receptors and binding proteins for soluble defence collagens. (Tenner, 1999).

Receptor/binding protein	Defence collagen	Cell expression	Function
Transmembrane receptors			
C1qRp	C1q MBL SP-A	Monocytes/Mø Neutrophils Endothelial cells Platelets Microglia	Enhance phagocytosis
C1qR ₀₂ - *	C1q	Neutrophils Eosinophils Smooth muscle cells	Trigger superoxide production
SPR210	SP-A	Bone marrow Mø Alveolar Mø Type-II cells Monocytes	Enhance phagocytosis Regulates PL secretion Regulates cytokine production
50-kDa	SP-A	Alveolar type-II cells	Uptake of PL
Binding proteins			
CR1	C1q/MBL	Monocytes/ Mø Neutrophils	?
Calreticulin	C1q/MBL/SP-A/ Conglutinin	Ubiquitous	Modulates C1q activity
gC1qBP/gC1qR	C1q [§]	Ubiquitous	Modulates C1q activity
gp340	SP-D, SP-A	Alveolar Mø	?

*C1qR₀₂- is the C1qR that mediates superoxide production. [§] gC1qBp/gC1R also binds to vitronectin and kininogen. Mø - macrophage.

1.16 GENOMIC ORGANISATION

The close relationship between SP-D and BC revealed by the amino acid sequence, showing 79% identity in their residues, is further emphasised by the similarities in their exon structure (Figure 1-18) (*Crouch et al.*, 1993; *Kawasaki et al.*, 1994; *Liou et al.*, 1994). Like SP-D, the conglutinin gene encompasses nine exons spanning more than 11kb. The human SP-D gene has been localised to 10q22.2-33.1 (*Crouch et al.*, 1993; *Kolble*, 1993; *Kolble et al.*, 1993; *Kolble and Reid*, 1993) near the genes for SP-A and MBL in the collectin gene cluster. The conglutinin gene has been assigned to band 18 on the chromosome 28, in Bovidae, by fluorescence *in situ* hybridisation (*Gallagher et al.*, 1993).

Collectin genes appear to have arisen by exon-shuffling event(s) that brought together exons encoding the NH₂-terminal collagenous domain and COOH-terminal CRD in a single protein. The similarity in the genetic organisation of SP-D and BC suggests the generation of conglutinin through a relatively recent gene duplication. The gene for the α -chain of human collagen-XIII is in close proximity to the collectin gene cluster (Table 1-8), suggesting that an ancestor for a superfamily of the gene cluster containing collagen-like regions and CRD may have had their origin at this location (*Hoppe et al.*, 1994).

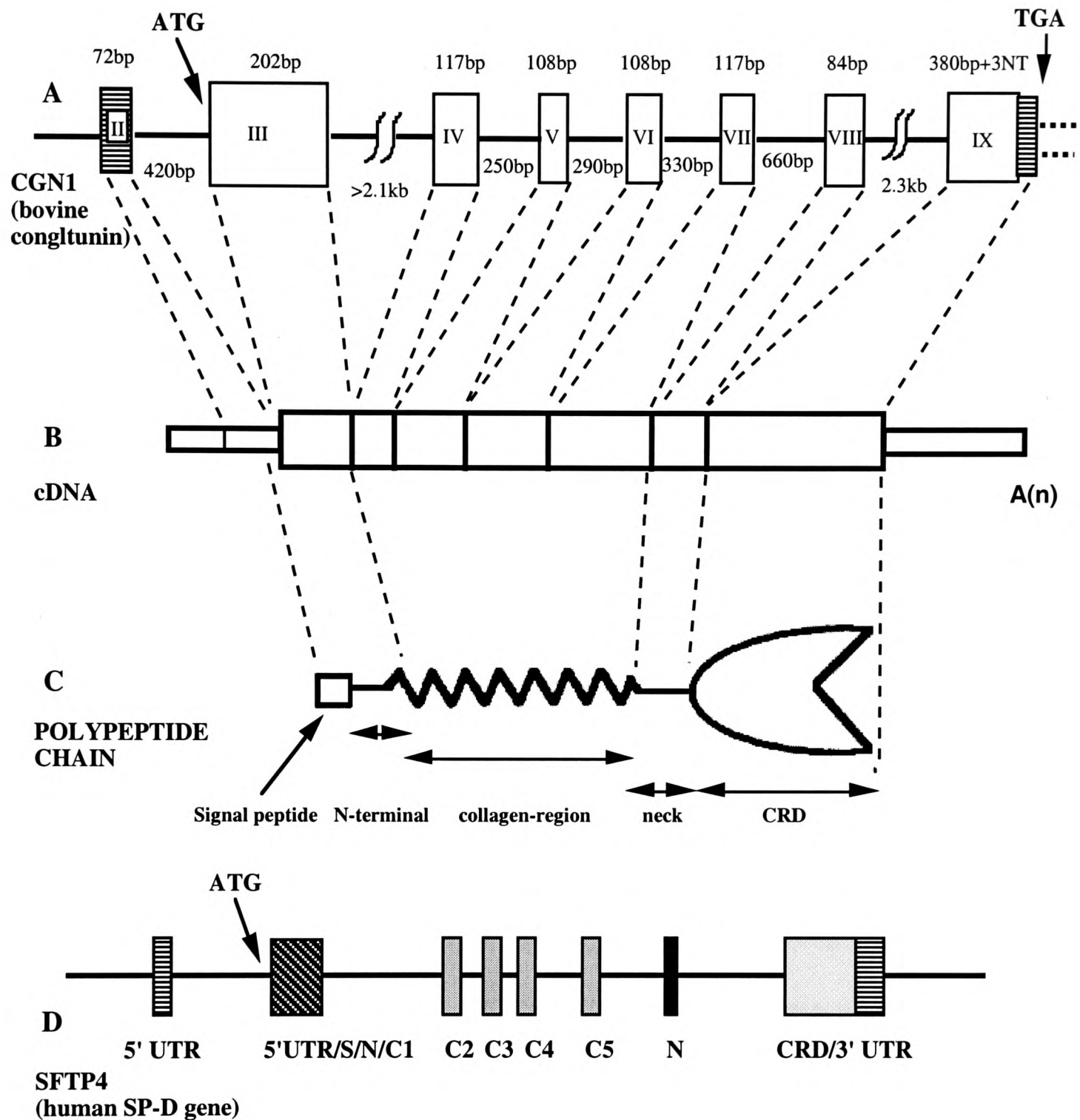

Figure 1-18: Comparative genomic organisation of Bovine Conglutinin and human lung Surfactant Protein-D.

(A) The organisation of the functional regions of bovine conglutin gene (CGN1) and (D) human SP-D (SFTP4). The exons have been numbered by Roman numeral and ■ represents untranslated regions (5'UTR/3'UTR), collagenous regions: C1-C5, IV-VII, neck region (N) and the carbohydrate-recognition domain VIII (CRD). (B) cDNA of BC showing regions encoded by the respective exons. (C) corresponding regions on the mature polypeptide chain. (Modified from (Crouch *et al.*, 1993; Kawasaki *et al.*, 1994; Liou *et al.*, 1994)

Table 1-8: Chromosomal localisation of C1q and members of collectin family

Name	Gene Symbol	Chromosomes	
		Bovine	Human
C1q			
A-chain	C1QA		1p 34.1 - p36.3
B-chain	C1QB		1p 34.1 - p36.3
C-chain	C1QC		1p 34.1 - p36.3
MBL	MBL		10q21
SP-A	SFTP1		10q22-q23
SP-D	SFTP4		10q22-q23
BC	CGN1	28q18 (Bos taurus)	-
CL-L1	CL-L1	-	8q23-24.1

1.17 EVOLUTIONARY RELATIONSHIP

The phylogenetic relationships (Figure 1-19) between the amino acid sequence of CRD of the members of collectin family reveals that the collectin family is made up of four classes: the MBL class consisting of MBL, MBL-A and MBL-C; the SP-D class, including SP-A, conglutinin and CL-43; the SP-A class and finally the CL-L1 class, which may be the first member of a new class (*Ohtani et al.*, 1999).

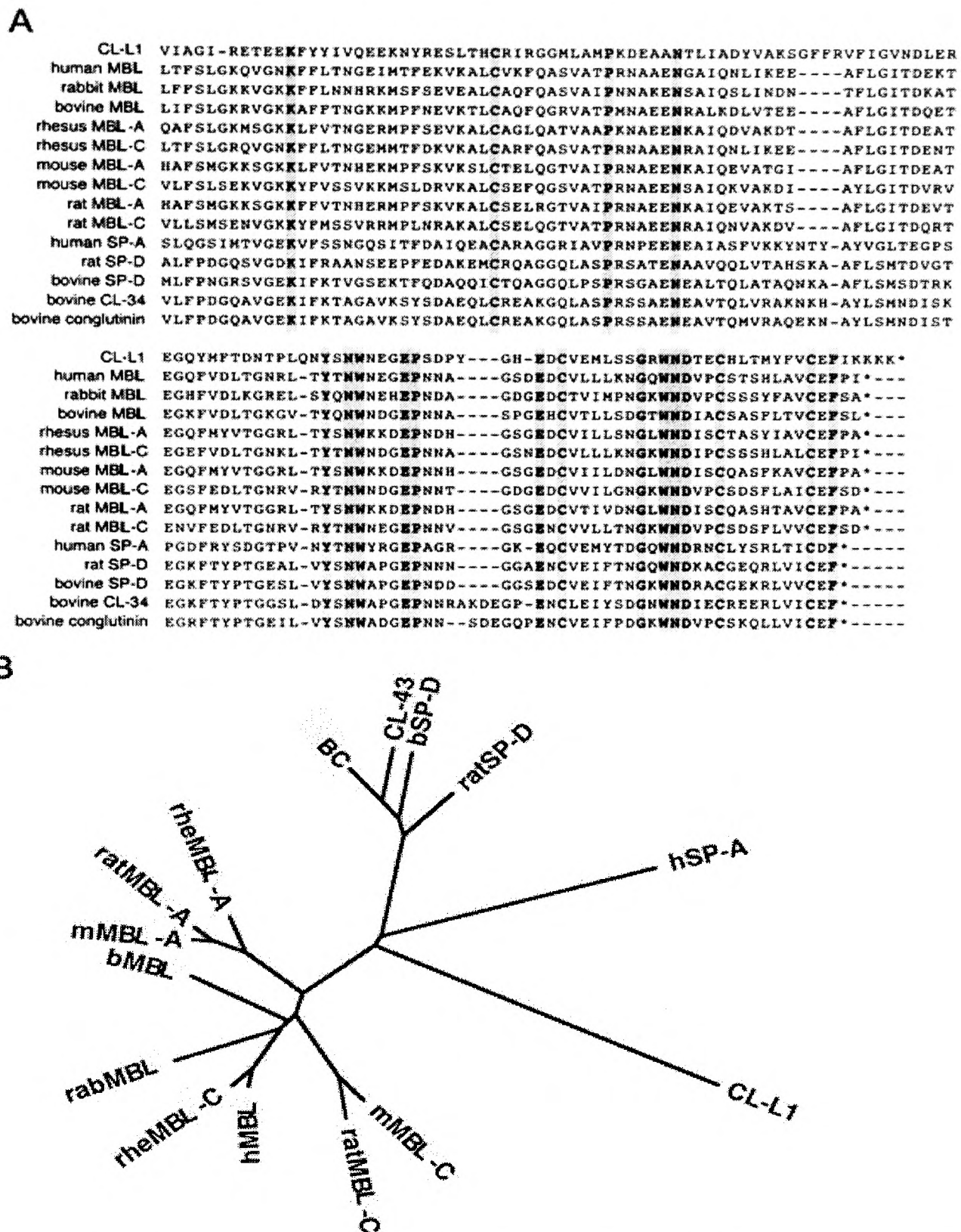

Figure 1-19: Alignments and phylogenetic tree of CL-L1 and several collectins.

(A) the amino acid sequences of CL-L1, human MBL, rabbit MBL, bovine MBL, rhesus MBL-A and MBL-C, mouse MBL-A and MBL-C, rat MBL-A and MBL-C, human SP-A, rat SP-D, bovine SP-D, bovine CL-43, and bovine conglutinin were aligned to look for comparisons. Shaded residues are identical. Dashes indicate gaps included for better alignment of the sequences to obtain maximal matching. (B) the phylogenetic relationships of collectins were determined by the neighbour-joining method using amino acid sequences of CRD fragments of CL-L1, human MBL (hMBL), rhesus MBL-C (rheMBL-C), rabbit MBL (rabMBL), bovine MBL (bMBL), mouse MBL-A (mMBL-A), rat MBL-A, rhesus MBL-A (rheMBL-A), mouse MBL-C (mMBL-C), rat MBL-C, bovine conglutinin (bCg), bovine CL-43, bovine SP-D (bSP-D), rat SP-D, and human SP-A (hSP-A) (Ohtani *et al.*, 1999).

CHAPTER - 2

2 MATERIALS AND METHODS

2.1 BIOCHEMICALS

General biochemicals and reagents were obtained from Aldrich Chemical Company Ltd., BDH Chemicals Ltd., BioRad, Difco Laboratories, Fluka, Flowgen Ltd., Gibco-BRL Ltd., ICN, Melford Labs National Diagnostics Ltd., Oxoid, Pharmacia Biotech Ltd., Pierce Ltd., Roche Diagnostics, Sigma Chemicals, Stratagene, unless stated otherwise. Solutions were sterilised where required, by autoclaving at 15 pounds per square inch for 20min or by passing through a 0.22 μ m filter (Millipore, Costar or Sartorius)

2.2 BACTERIAL STRAINS

The bacterial strains: NovaBlue, BL21(DE3), BL21(DE3)pLysS and AD494(DE3) were obtained from Novagen, and Y1088 and DH5 α were obtained from Stratagene. The genotype of these strains is shown in Appendix: C.

2.3 VECTORS

(Vector maps in Appendix: B)

pET-12a(+)	Novagen
pET-21a(+)	Novagen
pMal-c2	New England Biolabs
pET32a (+)Xa/LIC	Novagen

2.4 MOLECULAR BIOLOGY REAGENTS

QIAquick Gel Extraction Kit	Qiagen Ltd.
QIAfilter Plasmid Midi Kit	Qiagen Ltd.

Wizard PlusSV Minipreps	Promega
pfu Polymerase	Stratagene

2.5 IMMUNOLOGICAL REAGENTS

Goat anti-rabbit IgG-peroxidase conjugate	Sigma Chemicals
Extra-Avidin-peroxidase conjugate	Sigma Chemicals
Goat anti-rabbit IgG-FITC conjugate	Sigma Chemicals
Goat anti-rabbit IgG-Alkaline Phosphatase	Sigma Chemicals

Rabbit anti-BC (4.6mg/ml) was kindly gifted by Dr U. Holmskov (Odense, Denmark) and native Bovine conglutinin was provided by Dr Holmskov and Dr Stephen Thiel (Aarhus, Denmark). SP-D was purified by Peter Strong and anti-SP-D was provided by Dr Paul Eggleton (MRC Immunochemistry Unit).

2.6 CRYSTALLISATION REAGENTS

Crystal screens I and II	Hampton Research
24-well crystallisation trays	Nunc International
0.2mm plastic coverslips	BDH
Silicone grease	BDH

2.7 METHODOLOGIES

Standard procedures were used according to well established methods described in Molecular Cloning: a laboratory manual, second edition (*Sambrook*, 1986) and Current Protocols in molecular biology (*Ausubel et al.*, 1999) for general protocols, pET system manual (Novagen) for protein expression in *E. coli*, Manual for Protein purification, 2nd edition (Promega), and MBP fusion protein expression and purification manual (New England Biolabs). General protocols and

methodologies used have been described in this chapter, while the specific protocols are referred to in their respective chapters.

2.8 MOLECULAR BIOLOGY TECHNIQUES

2.8.1 STORAGE OF BACTERIAL CELLS

A single colony picked from a LB agar plate (Appendix: A.2.1) streaked with the transformants was used to inoculate 10ml of overnight culture. For short-term storage, the culture was streaked onto an agar plate with appropriate antibiotics and incubated overnight at 37°C. The plates were then sealed with laboratory film (Whatman) and stored at 4°C. The cells stored in this way remained viable for 2-3 months.

For long term storage of the strains, 50µl of overnight culture was subcultured in 5ml of the media and incubated at 37°C with good aeration at 225 rpm in an orbital shaker until the A_{600} reached 0.2. The cells were then harvested and resuspended in 90 parts of medium (without antibiotic) and 10 parts of Hogness buffer and stored at -70°C. The cells remain viable for 2-3 years or longer.

2.8.2 DNA EXTRACTION AND PURIFICATION

A single colony of Novablue cells transformed with the plasmid or the plasmid containing the recombinant fragment was used to inoculate 5 ml (mini preps) or 25-50 ml (midi preps) of LB broth and incubated overnight (12-16hrs) at 37°C with shaking (225rpm). The cells were harvested the following day at 3000 xg for 10min. The plasmid DNA was then extracted and purified using Promega's Wizard miniprep kit or QIAfilter midi kit.

2.8.3 DNA SEPARATION BY AGAROSE GEL ELECTROPHORESIS

A 50ml 1.0% (w/v) SeaKem Agarose gel was routinely used for analysis of 0.3-8.0kb DNA fragments. Agarose (SeaKem GTG, FMC BioProducts) was melted in 1x TE, cooled to 55°C, before adding ethidium bromide to a final concentration of 0.5µg/ml. The gel was cast in a horizontal 'minigel' apparatus (10cm x 7cm gel size). The gel was left to set at RT for at least 30min. Electrophoresis was carried out in horizontal apparatus with the gel submerged in 1x TE (containing 0.5 µg/ml ethidium bromide) at <100mA. DNA samples were loaded with one-fifth the volume glycerol-loading dyes. A standard 1kb DNA ladder (New England Biolabs) was also run along with the samples to allow estimation of the sizes of the DNA fragments. DNA fragments were visualised by fluorescence over a UV light (302nm, UV transilluminator TM-20, UVP), under which the DNA/ethidium bromide complex fluoresces. The image was recorded on a Mitsubishi video copy processor.

2.8.4 DNA PURIFICATION BY AGAROSE GEL ELECTROPHORESIS

When a particular DNA fragment was required, e.g. in ligations or as a PCR template, it was separated from other fragments by agarose gel electrophoresis. Gel slices containing the required DNA fragment were cut from the gel using a sharp razor blade (carefully avoiding exposure to UV light). DNA was then extracted from the gel slice using QIAquick Gel Extraction kit (Qiagen Ltd).

2.8.5 DNA SEQUENCING

The recombinant plasmid for sequencing were prepared either as bacterial colonies on an LB agar plate or as purified DNA template (using Promega's Wizard SV miniprep kit). The DNA was sequenced on a Perkin Elmer ABI Prism 377 automated DNA sequencer in the Department of Biochemistry or in the William Dunn School of Pathology sequencing facility.

2.8.6 PREPARATION OF COMPETENT CELLS

The *E.coli* cloning and expression strains were made competent using calcium chloride or rubidium chloride methods. The media used were autoclaved and the buffers were filter sterilised (0.2µM filter). The polypropylene microcentrifuge tubes pipette tips and buffers were pre-chilled to 4°C for use in transformations. The media and buffer compositions are detailed in Appendix: A.

Ice scrapings from the frozen glycerol stocks (as described in section 2.8.1 above) were streaked onto an LB agar plate with appropriate antibiotic and incubated overnight at 37°C. A single colony picked from the plate was used to inoculate 10ml of fresh LB media and incubated for 12-16 hrs at 37°C. The cells were subcultured in appropriate media for the respective transformation protocol.

2.8.6.1 CALCIUM CHLORIDE METHOD

500µl of an overnight bacterial culture (grown from a single colony of the appropriate *E.coli* strain) was used to inoculate 25 ml of fresh LB medium. The culture was grown at 37°C with good aeration to an A₆₀₀ of 0.4. The cells were then harvested at 3000 xg for 10mins at 4°C. The cell pellet was resuspended in

12.5 ml of sterile ice-cold 0.1M CaCl₂ solution and left on ice for 1 hr. The cells were re-pelleted and gently resuspended in 2 ml 0.1M CaCl₂ solution. The cells were kept on ice and used for transformation within 6 hrs. The surplus competent cells were stored as 50µl aliquots at -80°C. The cells retained transformation potential for up to 6 months.

2.8.6.2 RUBIDIUM CHLORIDE METHOD

The appropriate strain of *E.coli* was sub-cultured (500µl of overnight culture) into 100ml of ψ broth (Appendix: A.1.3) for 2 hrs at 37°C. The cells were harvested at 3000 x g for 10mins at 4°C and resuspended in, 2/5th of original culture volume, TFB1 (Appendix: A.3.1) and left on ice for 5min. The cells were harvested and resuspended in 1/25th the culture volume of TFB2 (Appendix: A.3.2) and placed on ice for 15mins. The cells were aliquoted and used for transformation immediately or stored at -70°C (where they remained competent for up to a year).

For subsequent transformations, the competent cells were obtained from Novagen.

2.8.7 TRANSFORMATION OF COMPETENT E. COLI CELLS

The competent cells were thawed on ice and mixed gently to ensure that the cells were evenly suspended. 50µl (Calcium chloride) or 20µl (rubidium chloride) competent cells were aliquoted into pre-chilled 1.5ml polypropylene microcentrifuge tubes. The plasmid was then added at a concentration of 1ng in a volume of 1µl to the tubes containing the competent cells and gently stirred to mix. The tubes were left on ice for 30min. The cells were subjected to a heat shock of 90 seconds at 42°C in a water bath. The tubes were then placed on ice for 5min. 1ml

of room temperature LB media was added to the cells and gently mixed. The tubes were then incubated at 37°C with shaking for 1 hour to allow the cells to recover. 200µl of the cells were used to lawn a LB agar plate with appropriate antibiotic. The plates were incubated overnight at 37°C. For testing the transformation with plasmid containing the gene of interest, the cells were plated on LB agar plates containing X-gal and IPTG as well, for blue-white screening. These plates were checked next day for white colonies (i.e. cells containing the recombinant plasmid).

2.8.8 TRANSFORMATION OF COMMERCIAL COMPETENT CELLS

Commercially obtained competent cells were thawed on ice and gently mixed. 10µl of the cells were placed in a pre-chilled 1.5ml polypropylene microcentrifuge tube. The plasmid with or without recombinant DNA fragment was added to the cells in a minimal volume of 1µl and stirred gently to mix. The cells were left for 30mins on ice. The cell suspension was then subjected to heat shock at 42°C for exactly 40 seconds on a water bath. The tubes were then left on ice for 2min. 80µl of room temperature SOC was added to the cells and incubated at 37°C for one hour with vigorous shaking at 225rpm. 50µl of cells were then spread on room temperature LB agar plates. For Blue-white selection were plated on LB agar plates containing X-gal and IPTG along with appropriate antibiotics. The plates were left on bench to allow excess liquid to be absorbed and then incubated overnight at 37°C.

2.8.9 PROTEIN EXPRESSION SYSTEMS

2.8.9.1 pET EXPRESSION SYSTEM

Target genes are cloned in pET plasmids under control of strong bacteriophage T7 transcription and translation signals; expression is induced by providing a source of T7 RNA polymerase in the host cell (Studier and Moffatt, 1986). T7 RNA polymerase is so selective and active that almost all of the cells resources are converted to target gene expression (Figure 2-1).

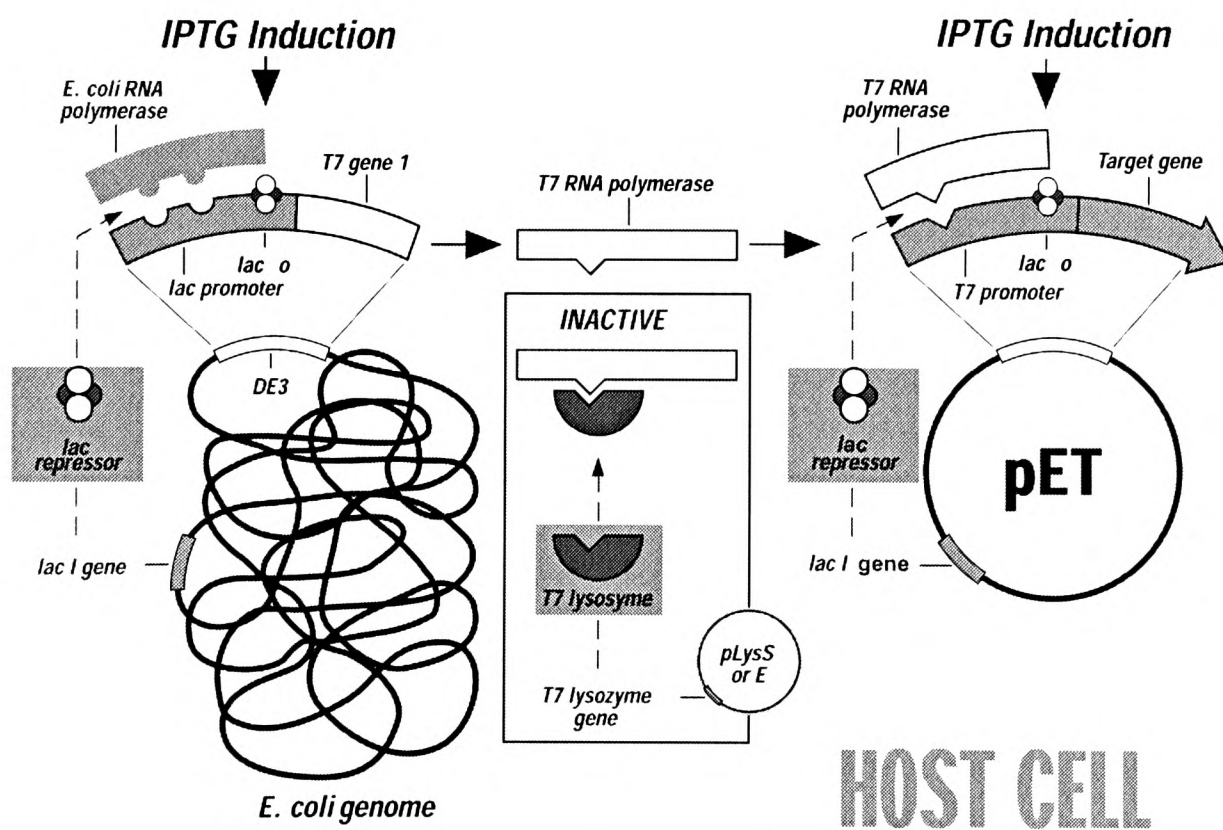

Figure 2-1: Control systems in pET expression systems.

The figure illustrates the vector and host elements available for control of T7 RNA polymerase levels and the subsequent transcription of a target gene in a pET vector. In λ DE3 lysogens, the RNA polymerase gene is under the control of *lac*UV5 promoter, allowing some expression in uninduced state. The pLys plasmids encode T7 lysozyme, which is a natural inhibitor of T7 RNA polymerase, thereby allowing for a stringent control on transcription.

The desired product can comprise more than 50% of the total cell protein in only a few hours after induction. Target genes are initially cloned using hosts that do not contain the T7 RNA polymerase gene, so they are virtually 'off' and cannot cause plasmid instability due to production of proteins potentially toxic to the host cell. Once established, plasmids are transferred into an expression host containing a copy of the T7 RNA polymerase gene (λ DE3) under *lacUV5* control, and expression is induced by addition of IPTG.

In λ DE3 lysogens, the T7 RNA polymerase gene is under the control of the *lacUV5* promoter, allowing some degree of transcription in the uninduced state. For stringent control, hosts carrying *pLysS* (Studier, 1991) or *pLysE* are used. The *pLysS* plasmids encode T7 lysozyme, which is a natural inhibitor of T7 RNA polymerase, and thus reduces its ability to transcribe target genes in uninduced cells.

2.8.9.1.1 pET-12a

For the protein to overcome the limitation of disulphide bond formation in the *E.coli* expression systems, the gene of interest can be cloned in pET vectors containing *ompT* or *pelB* signal. This signal sequence localises the translated protein to the periplasm, where the non-reducing environment facilitates the formation of disulphide linkages (reviewed by Wülfing (*Wulfing and Pluckthun*, 1994)). This process is further helped by the presence of molecular chaperones (*Bardwell*, 1994; *Gaitanaris et al.*, 1994) and *DsbA* (*Bardwell et al.*, 1991) (*Bulleid*, 1993); a protein involved in the disulphide bond formation in the periplasm.

In this study, pET-12a(*ompT*) (Appendix: B.1), initially cloned by Dr. K. Sastry (Boston Medical School, USA) has been used for expressing the recombinant fragment of conglutinin with the deletion of collagen region, as discussed in Chapter 6.

2.8.9.1.2pET-21a

The pET-21 vector is a transcription vector designed for expression from bacterial translation signals carried within the cloned insert. pET-21a(+) is a 5443bp plasmid . The recombinant neck and CRD of BC used in this study had been cloned by Dr Wang in the same laboratory (*Wang et al.*, 1995) in a modified pET-21a vector (Appendix: B.2).

2.8.9.1.3pET-32a Xa/LIC

The pET-32a Xa/LIC vector (Appendix: B.3) is designed for ligation-independent cloning and high-level expression of peptide sequences fused to the 109 amino acid thioredoxin (11,675Da; *trxA*, Trx•Tag) protein. Protein expressed in fusion with thioredoxin are produced in more soluble form. In addition pET32 Xa/LIC encodes the 6aa His•Tag and 15aa S•Tag sequences upstream of the cloning site for simple detection and affinity purification of the proteins. The N-terminal fusion sequences can be removed with thrombin (Trx•Tag and His•Tag) or Factor Xa (all three tags). The vector also carries the *T7lac* promoter, T7 transcription terminator, *lacI* gene, pBR322 origin of replication, f1 origin for single stranded plasmid production and *bla* gene for ampicillin (carbenicillin) resistance.

Ligation-independent cloning was developed for the directional cloning of PCR products without restriction enzyme digestion or ligation reactions (*Aslanidis and de Jong, 1990; Haun et al., 1992*). LIC vectors are created by treating a linearised backbone with T4 DNA polymerase in the presence of only one dNTP. The 3'→5' exonuclease activity of T4 DNA polymerase removes nucleotides until it encounters a residue corresponding to the single dNTP present in the reaction mix. At this point the 5'→3' polymerase activity of the enzyme counteracts the exonuclease activity to effectively prevent further excision. Plasmid sequences adjacent to the site of linearisation are typically designed to produce specific non-complementary 12 to 14 base single stranded overhangs in the LIC vector. Compatible inserts with complementary overhangs are generated by building appropriate 5' extensions into the primers. The PCR product is purified to remove dNTPs (and original plasmid if it was used as template) and then treated with T4 DNA polymerase in the presence of the appropriate dNTP to generate the specific vector-compatible overhangs. Cloning is directional, and is very fast and efficient because only the desired product is formed by annealing. The annealed LIC vector and insert are transformed into competent *E. coli* cells. Covalent bond formation at the vector-insert junctions occurs within the cell to yield circular plasmid.

2.8.9.2 MBP FUSION SYSTEM

Fusion systems allow the protein of interest to be expressed in tandem with a fusion partner, which acts as an affinity tag for purification of the target protein. In the case of pMal-c2, the cloned gene is inserted downstream from the *malE* gene of *E. coli*, which encodes the maltose-binding protein, resulting in the expression of a MBP-fusion protein. The method uses the strong “tac” promoter

and the *malE* translation signal to give high-level expression of the cloned sequence (and a one-step purification of the fusion protein using MBP's affinity for maltose). MBP2 is 42,170-kDa protein, which is cleaved from the protein by Factor Xa.

The "neck" and CRD of SP-D have been cloned (*Kishore et al.*, 1996) in the vector pMal-c2 (Appendix: B.4) and expressed as an MBP fusion protein.

2.9 PROTEIN CHEMISTRY TECHNIQUES

2.9.1 POLYACRYLAMIDE GEL ELECTROPHORESIS

Discontinuous SDS/PAGE was carried out as described by Laemmli (*Laemmli*, 1970). The acrylamide concentration for the resolving gel was 15% or 10% (w/v) and 5% (w/v) was used for the stacking gel. Two clean siliconised glass plates and 1.5mm spacers were aligned on a casting stand and clamped for a tight seal. The 15% acrylamide cocktail was poured between the two glass plates and 500 μ l of isopropanol was layered on top of the acrylamide solution. After the gel had set the surface of the gel was washed with deionised double distilled water. The stacking gel cocktail was then poured on top of the gel and a plastic comb with 80 μ l well volume inserted on the top and left for the gel to set. Once the gel had set the comb was removed and the unit was placed in BioRad Mini-ProteanII electrophoresis unit containing the running buffer. For native gels, 10% acrylamide concentration for resolving gel and 5% for the upper stacking gel.

Protein samples were prepared by adding one volume of 2x sample buffer containing 100mM Tris-HCl (pH 8.3), 4% (w/v) SDS, 0.2% (w/v) bromophenol Blue, 20% (v/v) glycerol and 1% (v/v) β -Mercaptoethanol (β -ME) for reduced

samples. For native gels, 40mM iodoacetamide was used to obtain unreduced samples. The samples were heated to 100°C on a heating block (TECHNE Dri-Block[®], DB-2A) for 5min prior to loading onto the gel. Broad range markers (New England Biolabs) or low range markers (BioRad) were run alongside the sample on every gel.

The gels were run at 60mV till the dye reached the gel interface and was then increased to 80mV till the dye front reached the end of the gel (~ 30min). After the run was over the gel was removed from the plates and placed in staining solutions. Protein bands were detected by the Coomassie-blue staining method^d. The gels were stored by drying them. The gel was put in a reservoir containing gel-drying solution for 10min and then placed on a wet drying film (Promega). Another sheet was placed on top of the gel. Care was taken to avoid any air bubbles and the sheets were then clamped on gel drying frames and rinsed with ethanol. The gel was then left to air dry.

2.9.2 ESTIMATION OF PROTEIN CONCENTRATION (BIORAD)

The protein concentration was estimated using BioRad protein assay, based on Bradford dye-binding procedure (*Bradford, 1976*). The procedure is based on the observation that the absorbance maximum for an acidic solution of Coomassie Brilliant Blue G-250 shifts from 465nm to 595nm when binding to protein occurs. 50µl of three dilution of the sample in triplicates were mixed with

^d Coomassie-blue staining method involved the detection of protein bands on the acrylamide gel by non-specific binding of Coomassie Brilliant Blue R to proteins. Acrylamide gel is immersed in dye solution in 50% methanol/10% acetic acid for 30min

2.5ml of five-fold diluted dye reagent and incubated for 5-10min. The absorbance was read at 595nm A standard curve was obtained by plotting A_{595} against varying concentrations of BSA (0.001-5.0 mg/ml).

2.9.3 HIGH PERFORMANCE LIQUID CHROMATOGRAPHY (HPLC)

The protein samples were run on an Atlantis C5 reverse-phase column - 150x2mm (Phenomex UK Ltd, Macclesfield, UK) equilibrated in 0.1% trifluoroacetic acid/2% acetonitrile. A linear gradient of 2-50% acetonitrile was applied over 50min followed by a linear gradient of 50-90% acetonitrile for 18min. The samples were run on an ABI 172a microbore HPLC system (Perkin Elmer, Applied Biosystems division, Warrington, UK). All signals were detected at E215 and data collected using Waters 'Expert Ease' software (Millipore Ltd, Watford, UK). This column run was done by Mr Anthony Willis in the unit.

2.9.4 N-TERMINAL SEQUENCING

The protein samples were run on a 4-12% (w/v) Bis-Tris NuPAGE precast gel (Novex UK Ltd) at 200mA per gel using Novex XCell II Mini-cell gel apparatus. The gel was electroblotted to ProBlott membrane (modified PVDF) (PE Applied Biosystems) in a BioRad Trans-Blot electrophoretic transfer cell. The membrane was then stained with Coomassie Brilliant Blue.

The band was then sequenced using Edman degradation reaction, on an Applied Biosystems 494A 'Procise' protein sequencer (PE Applied Biosystems, UK). The HPLC samples were also run on the sequencer. The samples were run on

followed by immersing in destaining solution (5% methanol and 7% acetic acid in water).

the sequencer by applying to a glass fibre disc pre-treated with polybrene to limit sample washout.

2.9.5 MASS SPECTROMETER

Mass determination by Electron Spray Ionisation-Mass Spectrometer (ESI-MS) was performed on a VG BIO Q triple quadrupole, atmospheric pressure mass spectrometer equipped with an electron spray interface operating in the positive ion mode (VG Biotech, Fisher Scientific, Loughborough, UK), by Dr R. T. Aplin in the Department of Chemistry. The samples were adjusted to approximately 25 picomoles/ μ l protein in 50% (v/v) acetonitrile, 1% (v/v) formic acid.

2.10 BIAANALYSIS

Real-time Biomolecular interactions analysis (BIA) is a biosensor technology, which uses precision microfluidics for delivery of the sample to a sensor surface (*Malmqvist and Karlsson, 1997*). BIA depends on the principle of Surface Plasmon Resonance (SPR), an optical phenomenon arising in thin metal films under conditions of total internal reflection.

2.10.1 PRINCIPLE

The detection principle relies on the optical phenomenon of surface plasmon resonance (SPR). At an interface between two transparent media of different refractive index (e.g. water and glass), light coming from the side of higher refractive index is partly reflected and partly refracted. Above a certain

The detection limit is 0.3 to 1.0 μ g/protein band.

angle of incidence no light is reflected across the interface and total internal reflection is observed. Although the incident light is totally reflected, an electromagnetic component called the evanescent wave penetrates a short distance (of the order of one wavelength) into the medium of lower refractive index (Figure 2-2). If the interface is coated with a thin layer of metal and the incident light is monochromatic and *p*-polarised (i.e. the electric vector component is parallel to the plane of incidence), the intensity of the reflected light is markedly reduced at a specific incident angle, producing a sharp shadow. This phenomenon is called *surface plasmon resonance* or *SPR*. The incident light angle at which the shadow is observed is called the SPR angle.

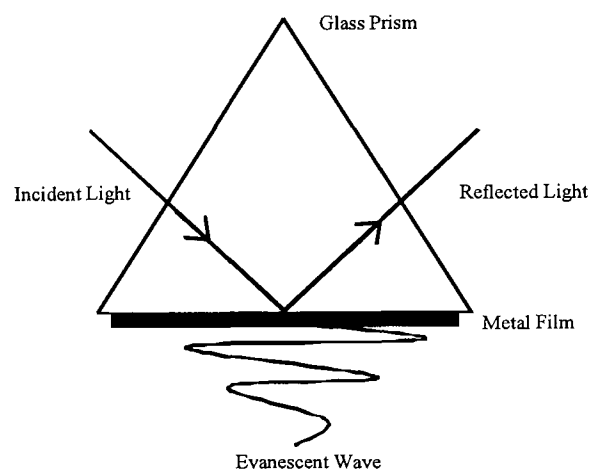

Figure 2-2: Principle of SPR.

Under conditions of total internal reflection at a metal-coated interface, an evanescent wave propagates into the medium of lower refractive index on the non-illuminated side.

The SPR angle depends on several factors, one of which is the refractive index of the medium into which the evanescent wave propagates, on the non-illuminated side of the surface. In real time BIA, the refractive index of the medium is affected by the surface concentration of solutes, so that the monitoring the SPR angle provides a real-time measure of changes in the surface concentration

(Figure 2-3). The other factors include the metal film properties, wavelength of the incident light and refractive index of the denser medium (glass) which are kept constant in real-time BIA.

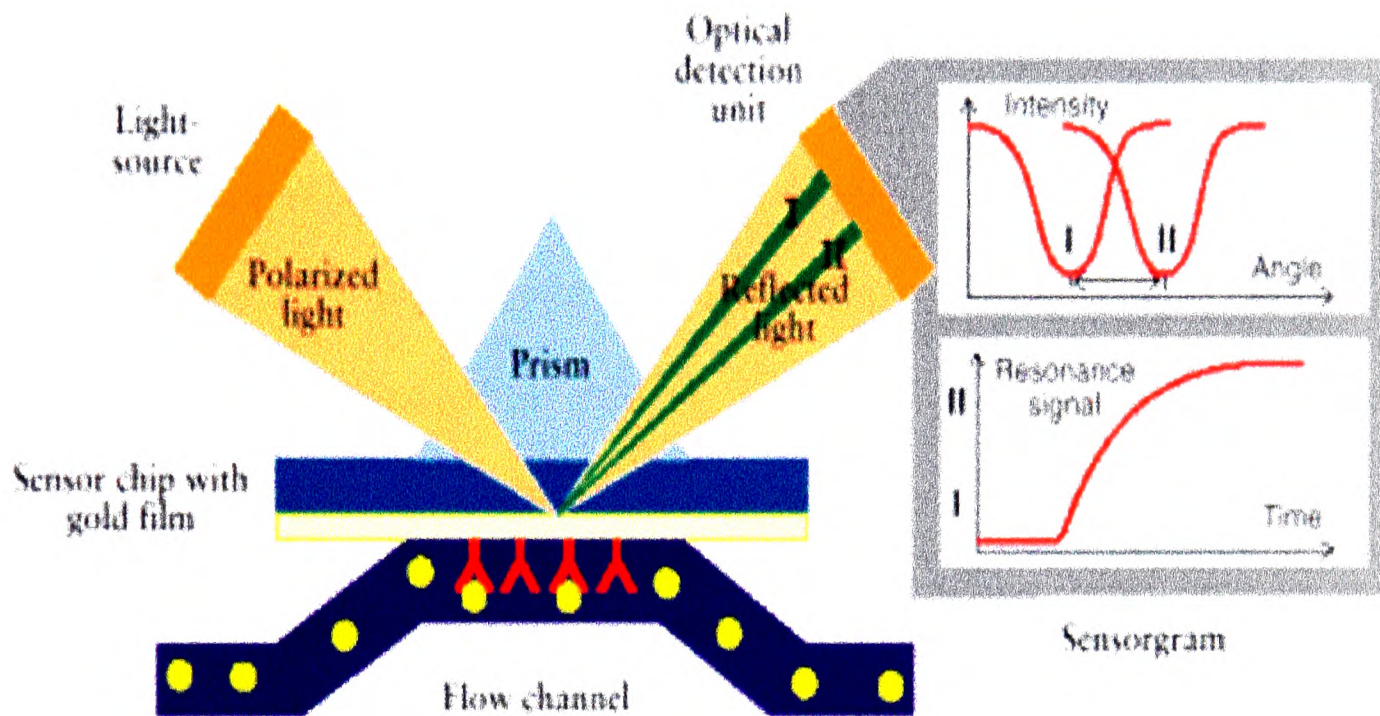

Figure 2-3: Schematic sensorgram showing association, equilibrium and dissociation phases.

The various events occurring at the sensor surface at particular phase are also illustrated. Continuous flow of liquid (sample buffer) over the sensor chip is maintained throughout the sensorgram. Sample is injected in a pulse from 100 to 300 s. Analyte binds to the surface during sample injection and dissociates when sample is replaced with buffer. The ordinate shows the SPR signal and the abscissa is real time in seconds.

2.10.2 SENSOR SURFACE

The metal film on the sensor chip is essential for the generation of an SPR signal. Gold is used in real-time BIA because it gives an SPR signal at a convenient

combination of reflectance angle and light wavelength and in addition is chemically inert to solvents and solutes typically used in biochemical contexts.

The gold film on the sensor chip is covered with a surface matrix (covalently attached through an inert linker layer) to which biomolecules may be immobilised using well-defined chemistry. The most versatile sensor chip CM5 consists of the carboxymethylated dextran as its matrix, linked with the gold film via a self-assembled monolayer of an ω -hydroxyalkanethiol. Because the matrix has significant extension (of the order of 100nm for sensor chip CM5), 'surface concentrations' on the sensor chip are strictly volume concentrations.

The matrix on CM5 chips consists of linear dextran which is swollen in aqueous media, providing an extensively solvated hydrogel. Attachment of biomolecules to this flexible dextran layer preserves a hydrophilic environment around the immobilised molecules and gives a high degree of accessibility.

2.10.3 LIGAND IMMOBILISATION

The design of a real-time BIA experiment is dictated primarily by the purpose of the investigation. The ideal ligand should (i) demonstrate high specificity, (ii) be able to withstand conditions of surface regeneration, (iii) be highly pure and (iv) of significantly different size than the analyte. The ligands may be immobilised (summarised in Figure 2-4) using any of the following strategies:

2.10.3.1 AMINE COUPLING USING REACTIVE ESTERS.

The carboxymethyl groups on the sensor surface are modified with a mixture of N-hydroxysuccinimide (NHS) and N-ethyl-N'-(dimethylaminopropyl)-

carbodiimide (EDC). This introduces N-hydroxysuccinimide esters into the surface matrix, which then react spontaneously with amines and other nucleophilic groups on the ligands to form covalent bonds.

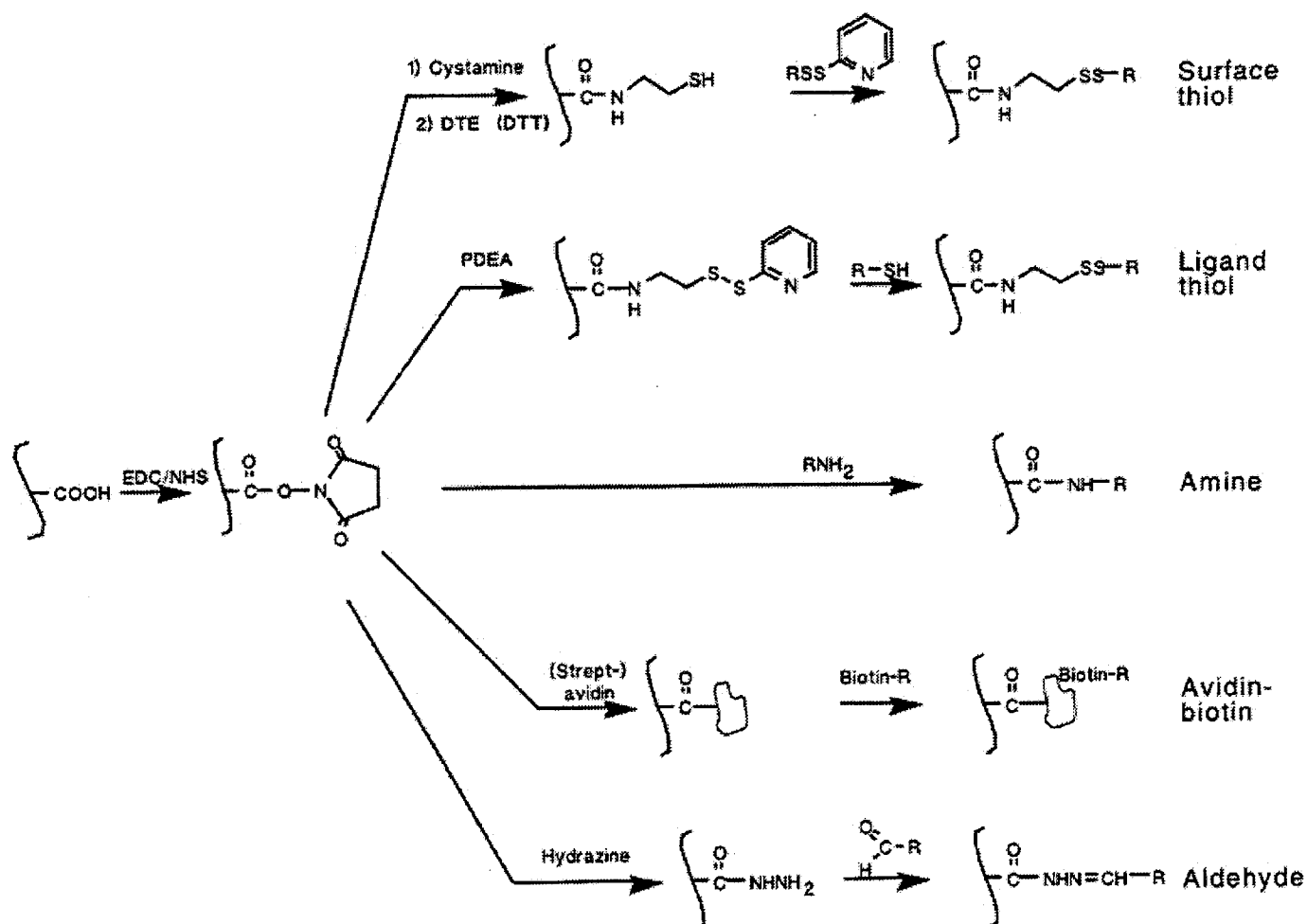

Figure 2-4: BIA coupling chemistries.

Overview of immobilisation chemistries for CM-series (carboxymethylated dextran) sensor chip.

2.10.3.2 COUPLING BY THIOL-DISULPHIDE EXCHANGE.

The procedure can use either intrinsic thiol groups in the ligand or reactive groups introduced by modification of the carboxy- or amine containing residues.

The coupling can be performed in two ways:

2.10.3.2.1 LIGAND-THIOL PROCEDURE

This involves introducing an active disulphide on the sensor chip surface and exchanging with intrinsic thiol groups in the ligand.

2.10.3.2.2 SURFACE-THIOL PROCEDURE

This procedure involves introducing an active disulphide on the ligand and exchanging with thiol-groups introduced on the sensor chip surface. This procedure is useful for coupling of ligands, which do not have intrinsic thiol groups.

2.10.3.3 BINDING BIOTINYLATED LIGANDS TO IMMOBILISED

STREPTAVIDIN.

Avidin or streptavidin immobilised on the sensor surface can be used to capture biotinylated ligands. Sensor chip SA5 is a sensor chip with pre-immobilised streptavidin, which can be used for capturing biotinylated ligands. This sensor chip has been used to measure binding of recombinant conglutinin to immobilised biotinylated mannan.

2.10.3.4 ALDEHYDE COUPLING TO A HYDRAZINE-ACTIVATED

SURFACE.

Ligands containing aldehyde groups (either native or introduced by oxidation of *cis*-diols) can be immobilised on a sensor chip surface activated by hydrazine or carbohydrazide.

2.10.4 SPR IN REAL-TIME BIA

The SPR signal originates in changes in the refractive index of a surface layer of both bulk solution and the surface matrix with adsorbed biomolecules (Figure 2-5). In most application the contribution of the bulk solution is eliminated

because the measured parameter is either the rate of change of the signal (binding kinetics) or the difference in signal between points before and after sample injection (amount bound). Measurements are made under conditions of continuous flow, where the biospecific sensor chip surface (containing the immobilised ligand) forms one wall of the flow cell. The analyte(s) flows over the surface in solution.

To perform BIA, sample containing the other interactant(s) is injected over the sensor surface in a controlled flow. Any change in the surface concentration resulting from the interaction is detected as an SPR signal, expressed in resonance units (RU) (Figure 2-3). At the end of the injection, the sample is replaced by buffer flow, and the change in signal now reflects dissociation of interactant from the surface-bound complex. The continuous display of RU as a function of time, called a sensorogram, provides a complete record of the progress of association and dissociation.

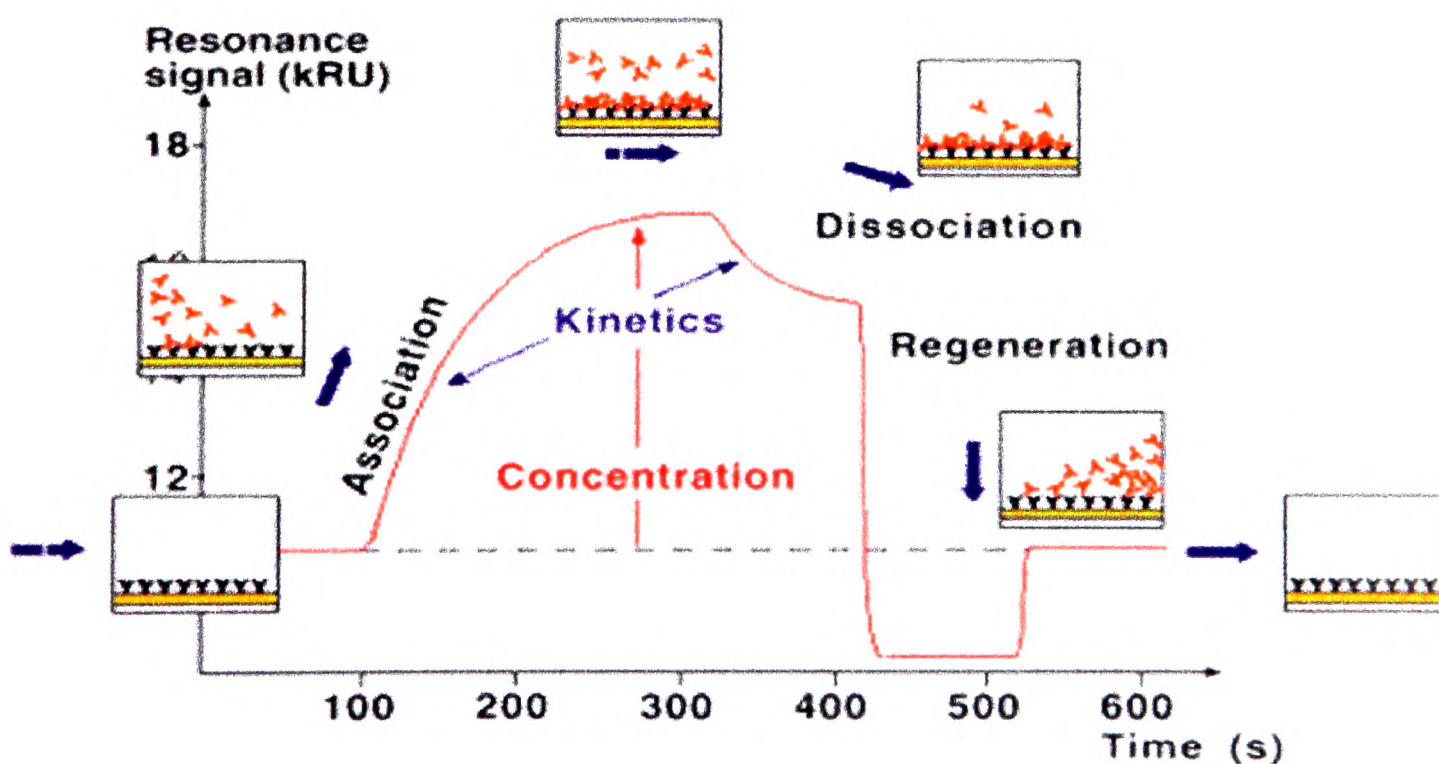

Figure 2-5: The SPR angle is sensitive to the mass concentration of the molecules close to the sensor chip surface.

As this concentration changes, the SPR angle shifts and produces the response corresponding to the events on the sensor surface.

The response resulting from an interactant is related to the change in mass concentration in the surface layer. The specific response is practically the same for all proteins and peptides and is similar for glycoproteins, lipids and nucleic acids. Specificity in BIA analysis is thus derived entirely from the interactive properties of the ligand on the surface and the analyte in the solution.

2.10.4.1 BASIC KINETIC MEASUREMENT

When analyte is injected in a discrete pulse across the ligand surface, the resulting sensorogram can be divided into three essential phases:

- Association of analyte with ligand during sample injection.
- Equilibrium or steady state during sample injection, where the rate of analyte binding is balanced by dissociation from the complex. (This is strictly a steady state since analyte is continually supplied and removed by sample flow. It can however be treated as an equilibrium condition provided that the flow is constant).
- Dissociation of analyte from the surface during buffer flow.

The association and dissociation phases provide information on the kinetics of the analyte-ligand interaction (i.e. the rates of complex formation and dissociation). The equilibrium phase provides information on the affinity of the analyte-ligand interaction (i.e. strength of binding), with suitable analysis of data, separate rate and affinity constants for the interactions from simple BIA

investigations. Direct kinetic measurements of this kind can be used for all analytes, which are large enough to give a measurable response.

2.10.4.2 COMPETITIVE KINETICS

Competitive binding situations arise when:

- two or more analytes compete for the same ligand (referred to as *surface competition*).
- the analyte and the immobilised ligand compete for binding to a third molecule in the bulk solution (referred to as *solution competition*).

In surface competitive methods, the analyte of interest is mixed with a high molecular weight (hmw) species, which compete with the analyte for binding to the ligand. The observed sensorogram reflects almost exclusively of the hmw component (depending of the ration of the molecular weights and the relative binding kinetics), but this is influenced by the presence of the lmw analyte. This approach is most suitable for comparative studies, and allows rapid affinity ranking of different lmw analytes, which bind to the same ligand. If they bind to different sites, the resulting sensorogram will reflect only the hmw kinetics.

In solution competition measurements, the analyte is mixed with an hmw interactant in free solution and allowed to reach equilibrium. Real-time BIA is used to assess the concentration of the free hmw interactant, from which the affinity of the interactant in solution can be determined.

2.10.5 METHODOLOGY

The real time BIAanalysis was performed on BIAcore 2000[®]. The responses were recorded and analysed by BIAevaluation software. The sensor chips, CM5 and SA, and reagents used were obtained from BIAcore Inc. The sensor chips with immobilised ligands were stored in 5% (v/v) ethanol.

2.10.5.1 REAGENTS

1. *Continuous Flow Buffer*: HBS Buffer, BIA Certified (10mM HEPES pH 7.4, 150 mM NaCl, 3.4mM EDTA, 0.005% (v/v) surfactant P20)
2. *NHS/EDC*: 100mM NHS in water mixed with equal volume of EDC in water (final concentrations 50mM and 200mM respectively).
3. *Activation solution*: 80mM 2-(2-pyridineyldithiol)ethaneamine (PDEA) solution in 0.1M borate buffer pH 8.5 (prepared one hour before use).
4. *Deactivation solution*: 50mM l-cysteine-1M NaCl deactivation solution in 0.1M formate buffer pH 4.3 (prepared an hour before use).

2.10.5.2 IMMOBILISATION OF iC3b

Complement component iC3b (*Micklem et al.*, 1984) was immobilised onto sensor chip CM5 using ligand-thiol coupling method. The reagents were injected at a flow rate of 5 μ l/min into the flow cell.

2.10.5.2.1 ACTIVATION

The sensor chip CM5 was first activated with a 2min pulse of 0.05M NHS/EDC. This was followed by a 4min pulse of 80mM PDEA in 0.1M borate buffer pH 8.5.

2.10.5.2.2 LIGAND IMMOBILISATION

Complement component, iC3b at a concentration of 100µg/ml in HEPES buffer (pH 7.4) was injected into the flow cell as a 7min pulse.

2.10.5.2.3 DEACTIVATION

Excess reactive groups remaining on the surface of the sensor surface after immobilisation are deactivated to avoid non-specific binding. A 4min pulse of 50mMl-cysteine-1M NaCl in formate buffer pH 4.3.

2.10.5.3 IMMOBILISATION OF BIOTINYLATED MANNAN

Sensor chip SA5 has pre-immobilised streptavidin on the sensor surface available for capturing biotinylated ligands. The chip was primed with the continuous flow buffer, HBS. Biotinylated mannan (1.35ng/ml in 10mM acetate buffer) was injected into the flow cell at a flow rate of 5µl/min. all the four flow cells were saturated with mannan.

CHAPTER - 3

3 RECOMBINANT BOVINE CONGLUTININ

3.1 INTRODUCTION

Bovine conglutinin (BC) is a serum protein identified so far in Bovidae only. It belongs to the family of C-type lectins; 'collectins' characterised by four domains *viz.* cysteine-rich N-terminal region followed by collagen-like domain linked to the C-terminal CRD via an α -helical coiled-coil neck region. The native molecule presents a cruciform shape with the trimeric CRD heads radiating from a central hub.

Residues 195-351 of the native conglutinin encompassing the neck region and CRD have been used in this study. This recombinant fragment (**Figure 1-9**) had been previously cloned by Dr J. Y. Wang in this laboratory, in a modified vector pET-21 (*Wang et al.*, 1995). This clone was purified from DH5 α and used to transform competent NovaBlue cells for maintaining the plasmid. To express the recombinant protein an *E.coli* strain BL21(DE3)pLysS (described in section 2.8.9.1) was used.

3.2 EXPRESSION IN BL21(DE3)

Initial attempts to express rBC(N/CRD), were carried out using the expression host BL21(DE3). The cells were grown in LB media containing ampicillin (100 μ l/ml) and incubated at 37°C. The cells were induced at OD₆₀₀ of 0.6, with IPTG (0.5mM final concentration) and incubated further for 3hrs. No significant increase in expression was observed as compared to the uninduced cells as shown in Figure 3-1. The recombinant protein aggregated soon after dialysis and did not retain binding affinity for sugars, as assessed by ELISA (data not shown).

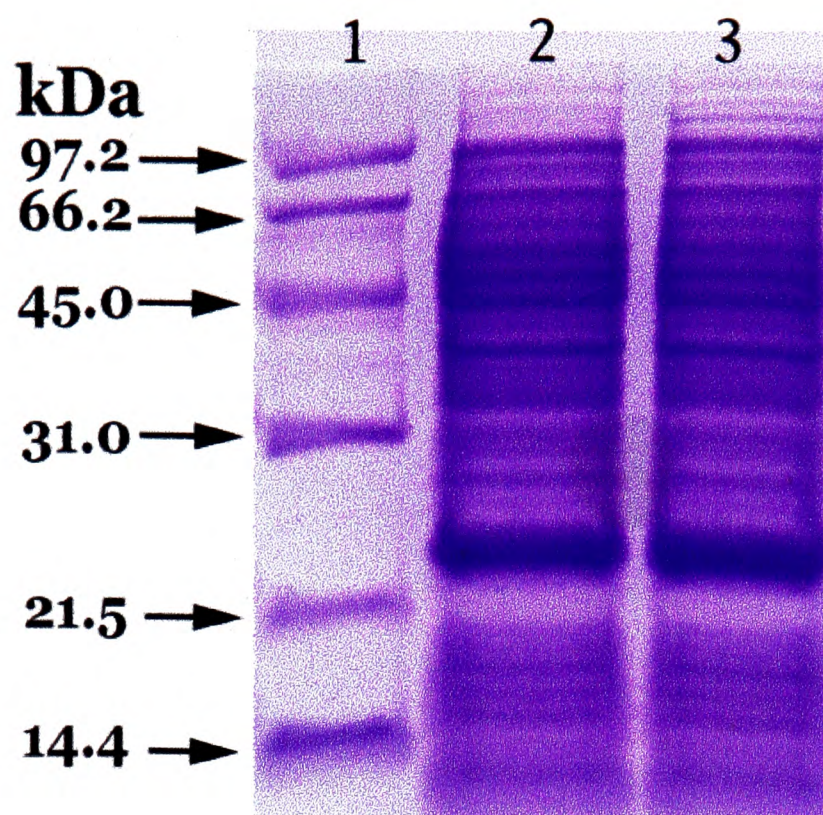

Figure 3-1: SDS-PAGE analysis of recombinant Bovine Conglutinin expressed in BL21(DE3).

The recombinant protein comprising neck and CRD was expressed in the E. coli strain BL21(DE3). The cells were induced at A_{600} of 0.6 with IPTG (0.5mM final concentration). Lane-1: low mol wt markers, lane-2: uninduced cell lysate (20 μ l) and lane-3: induced cell lysate (20 μ l).

A new expression host BL21(DE3)pLysS was used to express the recombinant protein. This strain exerts tight control over protein expression. No basal level of recombinant protein was observed in the uninduced state. Upon induction with IPTG a higher level of expression was observed in the host cell (Figure 3-2). The conditions for optimal expression of recombinant protein in this strain were standardised. Other modifications are mentioned at relevant steps in the protocol.

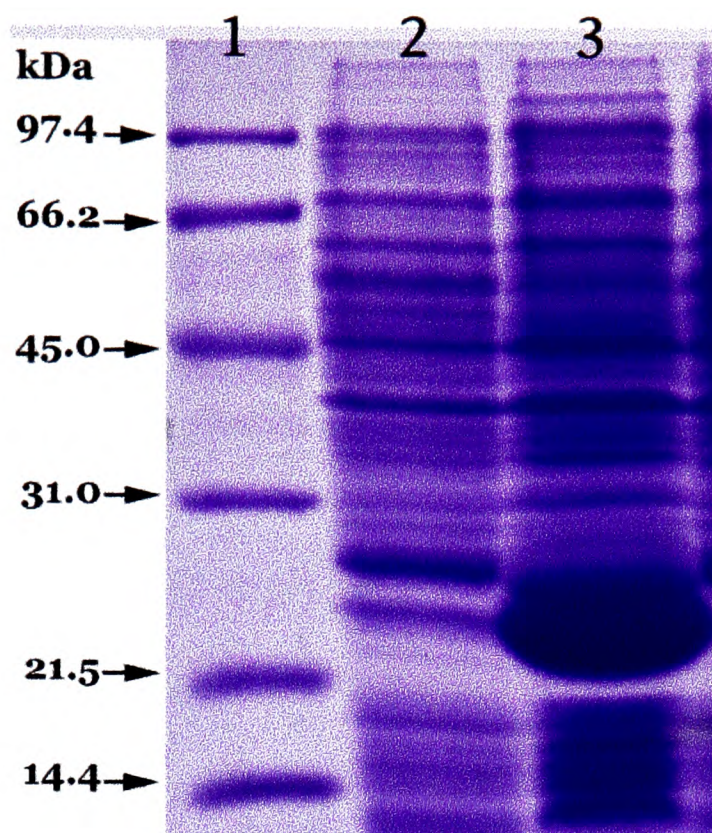

Figure 3-2: SDS-PAGE analysis of the induction of rBC(N/CRD) in BL21(DE3)pLysS.

Cells were induced with IPTG (0.5mM final concentration) and harvested two hour post-induction. 20 μ l of total cell lysate was loaded per well. Lane-1 shows the low molecular weight markers; lane-2: uninduced cell lysate and lane-3: induced cell lysate.

3.3 EXPRESSION AND PURIFICATION

3.3.1 METHODS

3.3.1.1 PROTEIN EXPRESSION

A single colony was picked from a LB agar plate (containing 50 μ g/ml carbenicillin and 34 μ g/ml chloramphenicol) streaked with BL21(DE3)pLysS containing the recombinant plasmid and was used to inoculate 10 ml of LB media. The culture was incubated overnight at 37°C with vigorous shaking (225rpm). The cells were harvested next day at 2000 xg and washed once in fresh LB media. The cell pellet was then resuspended into 5ml of fresh media and used as inoculum for 1 litre of fresh LB media containing antibiotics: chloramphenicol (34 μ g/ml) and carbenicillin (50 μ g/ml) and incubated at 37°C with vigorous (225rpm) shaking.

The cells were induced at A_{600} of 0.6, with IPTG (final concentration 0.5mM) and incubated further for 2hr. The culture was then chilled on ice for 30 min with gentle shaking. The cells were harvested at 8000 xg for 10 min at 4°C and washed once with fresh media.

3.3.1.2 PROTEIN EXTRACTION

The cell pellet was resuspended in 25ml of ice-cold cell-lysis buffer (50mM Tris-Cl {pH 8.0}, 150mM NaCl, 5mM CaCl₂) and frozen at -80°C. The cells were either thawed soon afterwards to proceed with protein purification or stored at -20°C for later use. The cells were thawed on ice in cold room (4°C) and the remaining 25ml of the lysis buffer containing Triton X-100 (final concentration 0.05% v/v), DNase (5µg/ml), MgCl₂ (0.04M) and proteases inhibitor tablet (Appendix: A.13), was added. The freeze-thawing of the *pLysS* containing expression strain causes the cell wall and membrane to rupture, thus releasing the intracellular contents into the media or buffer solution. This procedure eliminated the use of lysozyme and detergents. The thawed cell suspension was left on an end to end shaker at 4°C for 45 min. The lysate was then sonicated with ten 30s pulses of 16µs amplitude at 15 seconds interval. After sonication, the cell soup was centrifuged at 15000 xg. The protein pelleted as inclusion bodies and the supernatant was discarded. The pellet containing the inclusion bodies was washed twice with ice-cold deionised water to remove traces of TritonX-100.

The pellet was then subjected to a denaturing and refolding procedure, involving repetitive dialysis against reducing concentrations of urea, from 6M reducing to zero. The pellet was resuspended in dialysis buffer (20mM Tris-Cl,

150mM NaCl, 5mM CaCl₂ and 5% v/v glycerol) containing 6M urea and was left on an end to end shaker for 30 min at 4°C. The denatured protein solution was centrifuged to remove insoluble material. An activated dialysis membrane^e (10k MWCO) tubing was filled with the cleared supernatant and placed in 2 litres of dialysis buffer containing 4M urea. The protein was dialysed at 4°C against reducing concentrations of urea with buffer changes every 2 hrs. An additional 24hr dialysis was done to remove traces of urea. The dialysate was then centrifuged at 15000 xg to remove any contaminating aggregates.

Before use, urea solutions were passed through "Duolite" MB6113 (indicator) mixed resin (BDH) to remove traces of cyanate ions, which may irreversibly binds to the protein and affect its function.

3.3.1.3 PROTEIN PURIFICATION

3.3.1.3.1 AFFINITY PURIFICATION

The supernatant containing the folded recombinant protein was loaded onto a freshly-packed 10ml mannan-agarose affinity column^f and washed with two column volumes of Tris-buffer (pH 8.0) containing 5mM CaCl₂ and 150mM NaCl. The bound rBC(N/CRD) was then eluted as 2ml fractions, in Tris buffer containing

^e The Medicell Dialysis membrane (10k MWCO) was boiled in double distilled water containing 2%(w/v) NaHCO₃ and 1mM EDTA (pH 8.0) for 10 min. The tubing was then boiled in 1mM EDTA solution (pH 8.0) for 10mins. The tubing was then cooled and washed with deionised water before use. Alternatively, the tubing can be stored in the EDTA solution containing 0.02% (w/v) sodium azide. The tubing can be stored for up to 6 months at 4°C.

^f Affinity purification on mannan-agarose was not used in later preparations, and ion-exchange columns, since Q-Sepharose and MonoQ provided clean preparations with minimal loss of protein.

100mM EDTA. The fractions were analysed by SDS-PAGE on a 15% (w/v) acrylamide gel. The peak fractions were pooled and subjected to further purification and concentration.

3.3.1.3.2 ION-EXCHANGE PURIFICATION

The affinity-purified recombinant protein was loaded through Fast flow Q-Sepharose (12/40) column in Tris-buffer containing 5mM CaCl₂ and 50mM NaCl. 50ml were injected into the column through a 50ml superloop (Pharmacia Biotech) at a flow rate of 1ml/min and run on Pharmacia Biotech AKTA purifier FPLC system. A two-step linear gradient: 0-50% and a steep gradient to 100% buffer B (Tris-buffer containing 1M NaCl), was used to elute the protein as 2ml volume fractions. The fractions were analysed by SDS-PAGE on 15% (w/v) discontinuous acrylamide gel. The peak fractions containing the recombinant protein were pooled and were subjected to further purification and characterisation on a gel-filtration column.

3.3.1.3.3 GEL-FILTRATION CHROMATOGRAPHY

The protein was purified on pre-packed Superose-12 (HR 10/30)^g and Superdex (HR 10/30) columns, on the Pharmacia Biotech AKTA purifier FPLC system. Protein sample in 200µl and 500µl volume respectively, were loaded onto the column in Tris-buffer, containing either 5mM CaCl₂ or 10mM EDTA.

^g The elution profile of the recombinant protein when run in EDTA containing buffer on the Superose-12 column revealed a lower retention volume as compared to that in calcium-containing buffer. This may be due to possible interaction of the protein with the resin. This aberration was not observed with Superdex-75 column, which was then used for all gel-filtration applications.

The column was run at a flow rate of 0.5ml/min (Superose) or 1ml/min (Superdex75) and 0.5ml fractions collected. The absorbance was read at 280nm, 260nm and 225nm. The data was collected and analysed using Unicorn software. Alcohol Dehydrogenase (150KDa), BSA (66KDa) and Carbonic Anhydrase (29KDa) were used to calibrate the column.

The peak fractions containing the recombinant protein rBC(N/CRD) were pooled and used for biochemical and functional characterisation. Protein concentration was determined by Bradford dye-binding method (described in [section 2.9.2](#)).

All the buffer solutions used in the chromatographic applications were passed through 0.2µm filter and degassed before use. The protein sample before loading onto the column was passed through Anotop 0.2µm filter (Whatman).

3.3.2 RESULTS

3.3.2.1 EXPRESSION

The recombinant protein comprising of the CRD and neck regions of the conglutinin was expressed in BL21(DE3)pLysS. A high level of expression was observed after induction with IPTG (0.5mM). The cells were harvested after two hours post-induction, which was optimal for maximum yield with minimal degradation. The cells were frozen-thawed and sonicated to extract the protein. Almost all of the protein was found in the inclusion bodies, as observed by the absence of the corresponding protein band in the sonicate supernatant ([Figure 3-3, lane-6](#)).

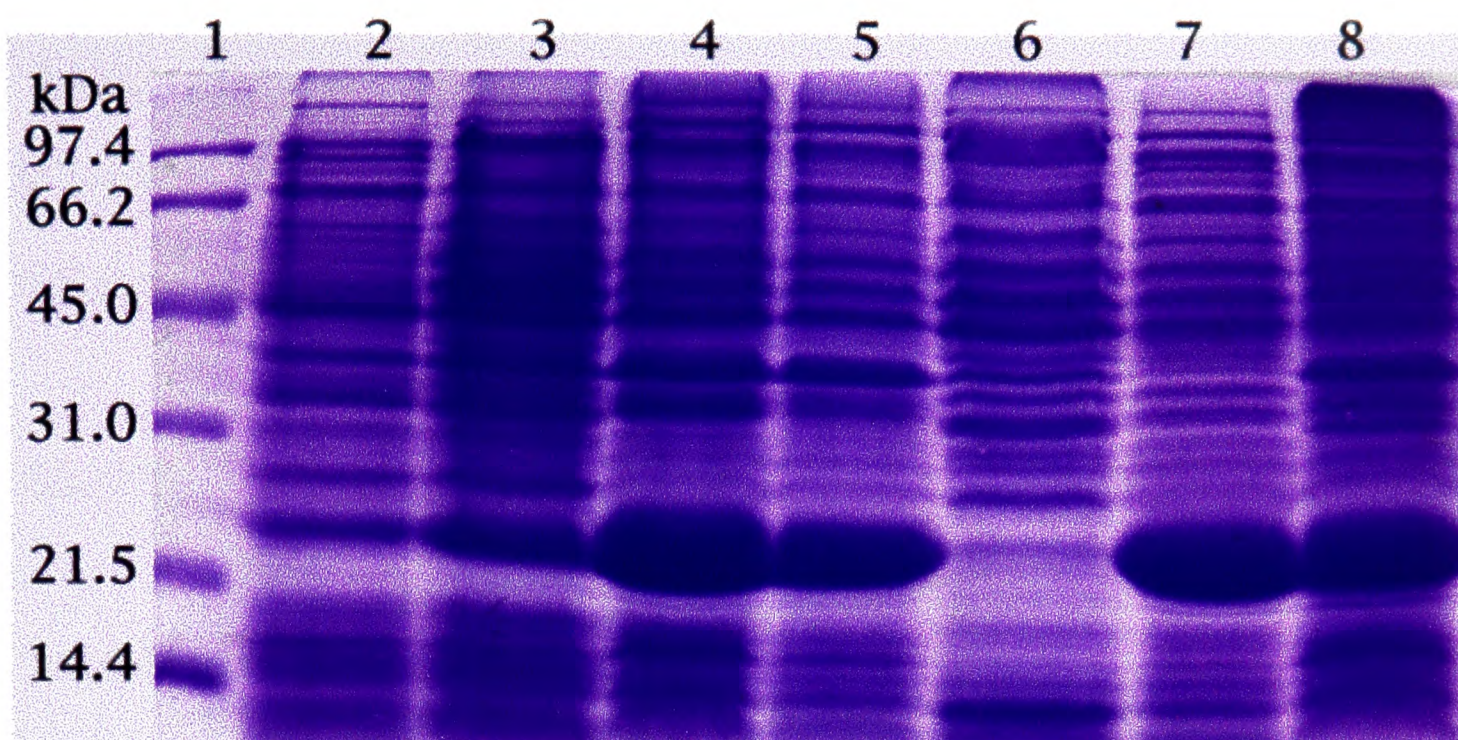

Figure 3-3: Expression of recombinant Bovine Conglutinin.

Lane-1 shows low molecular weight markers. Lanes 2-8 show various steps in expression and purification of rBC(N/CRD). The samples were heated to 100°C for 5min (10min for total cell lysates). 20µl of each sample was loaded onto the wells and run on a 15%(w/v) acrylamide gel. Lane-2: total cell lysate of uninduced cells; lane-3: total cell lysate of induced cells harvested after 1hr post-induction; lane-4: total cell lysate of induced cells harvested after 2hr post-induction; lane-5: pellet after sonication (5µl); lane-6: supernatant after sonication; lane-7: dialysate of soluble proteins extracted from the pellet; and lane-8: residual pellet after dialysis (containing aggregated protein and contaminants).

The protein in the inclusion bodies was solubilised by denaturing with 6M urea and subsequently refolded by dialysing against reducing concentration of urea to zero. The recombinant fragment showed a relative mol. wt. of approximately 23 kDa, under reduced conditions on a 15% (w/v) acrylamide gel, corresponding to the monomeric recombinant protein (Figure 3-3, lane-7). The conditions were further optimised for better and purer yield (Figure 3-4, lane-5).

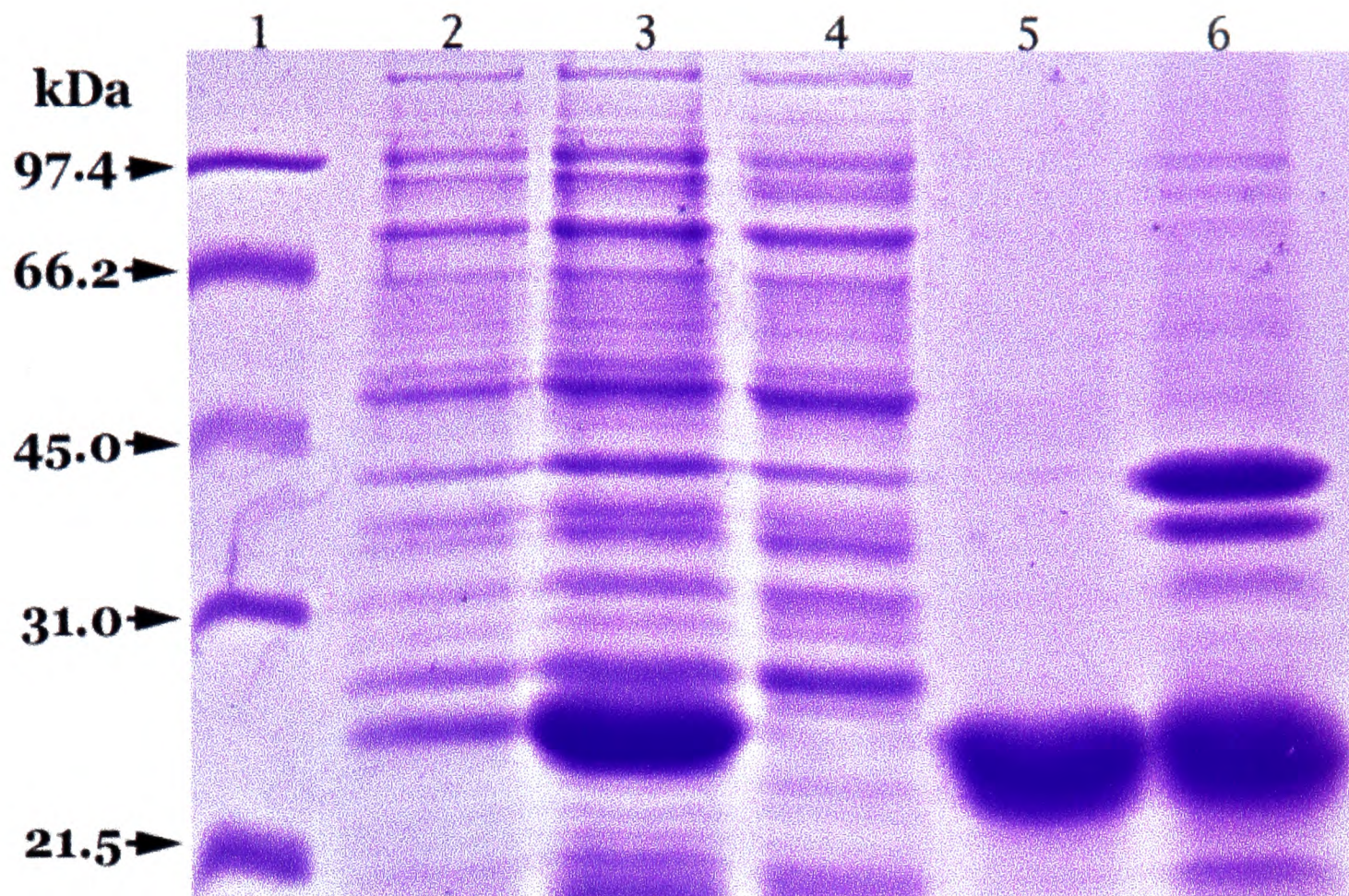

Figure 3-4: Expression and dialysate analysis of rBC(N/CRD).

The recombinant protein was expressed in expression host BL21(DE3)pLysS. Lane 1 shows low molecular weight markers, lanes-2 through 4 show recombinant conglutinin expression and purification steps. Lane-1: total cell lysate of uninduced cells; lane-2 total cell lysate of induced cells harvested 2hr post-induction and chilled for 30min on ice with shaking; lane-4: sonicated supernatant; lane-5: refolded protein after overnight dialysis; and lane-6: dialysate pellet containing insoluble material. The recombinant protein obtained was purer than previous preparation (Figure 3-3). Following preparations were of same quality and were used in experiments and concentrated for crystallisation trials.

3.3.2.2 PURIFICATION

The refolded protein was purified on mannan-agarose affinity column. Excess protein or contaminants passed through the column during washing with calcium buffer. The recombinant protein eluted as a single peak in 100mM EDTA (Figure 3-5). The fractions were analysed on SDS-PAGE for purity (

Figure 3-6). The fractions containing the recombinant protein were pooled and loaded onto an ion-exchange column.

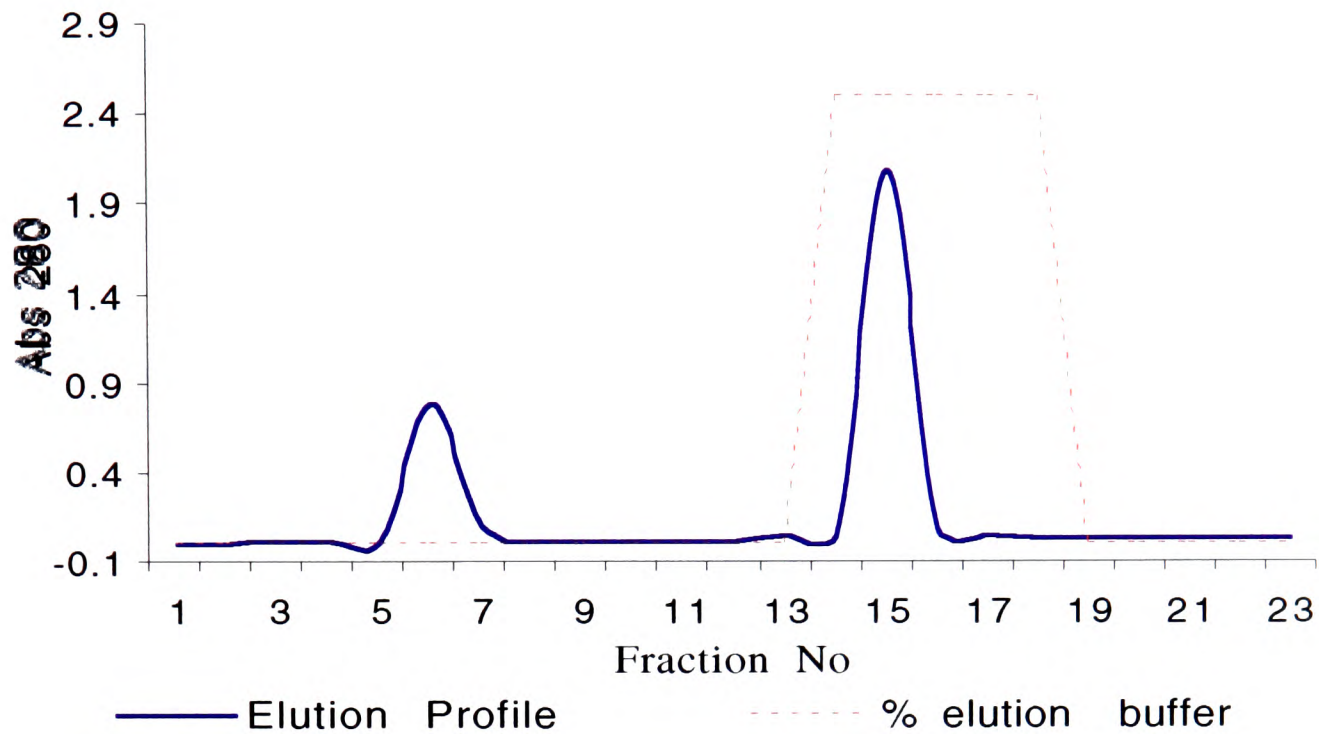

Figure 3-5: Elution profile of the rBC(N/CRD) on mannan-agarose column. The dialysed supernatant containing the refolded protein was loaded onto a 10ml freshly-packed mannan-agarose column in tris buffer (pH 8.0) containing 5mM CaCl₂ at a flow rate of 1ml/min. Excess protein and contaminants flowed through the column during washing with tris buffer. The bound protein was eluted in tris buffer containing 10mM EDTA.

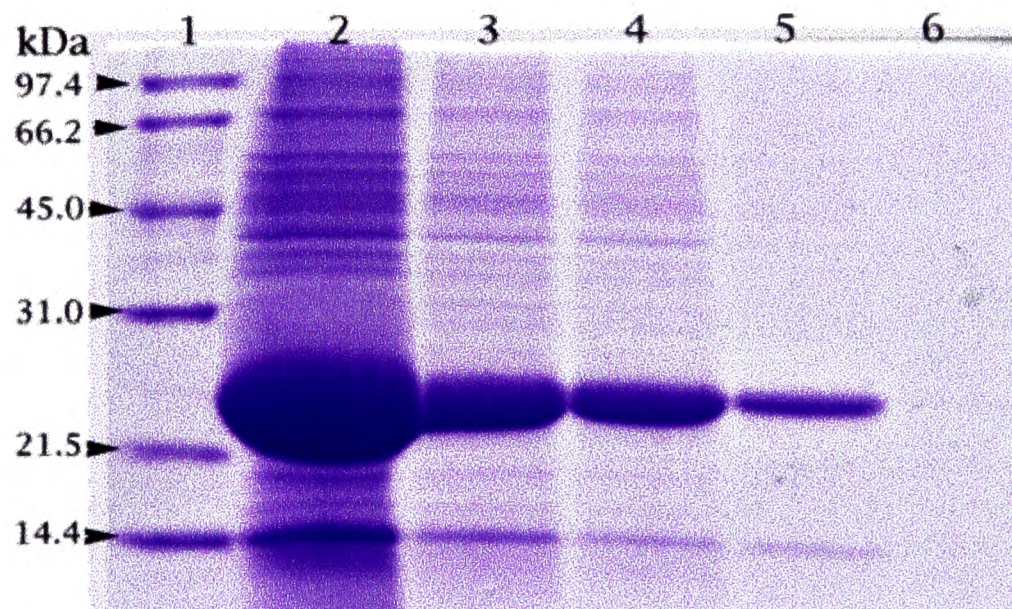

Figure 3-6: SDS-PAGE analysis of the fractions from Mannan-agarose column.

Lane-1 shows low weight molecular markers. Lanes 2 through to 6 correspond to fractions 7, 14, 15, 16 and 17, respectively. The sample for flow-through (Figure 3-5) fractions (5-8) was concentrated by using strataclean beads (Stratagene) before loading onto the gel. Excess protein and contaminants flowed through the column, this fraction was reloaded onto the column to recover the recombinant protein.

The pooled affinity-purified protein was applied on to the ion-exchange columns, Q-Sepharose (Figure 3-7) and Mono-Q (Figure 3-8) after diluting with starting buffer to lower the sample salt concentration. Excess protein flowed through during sample loading. The protein eluted as a single peak (Figure 3-8) at approximately 225 mM salt concentration.

The concentration on the recombinant protein over various preparations was in the range of 0.5-0.8 mg/ml (~40mg protein per litre culture), as determined by Bradford dye-binding method.

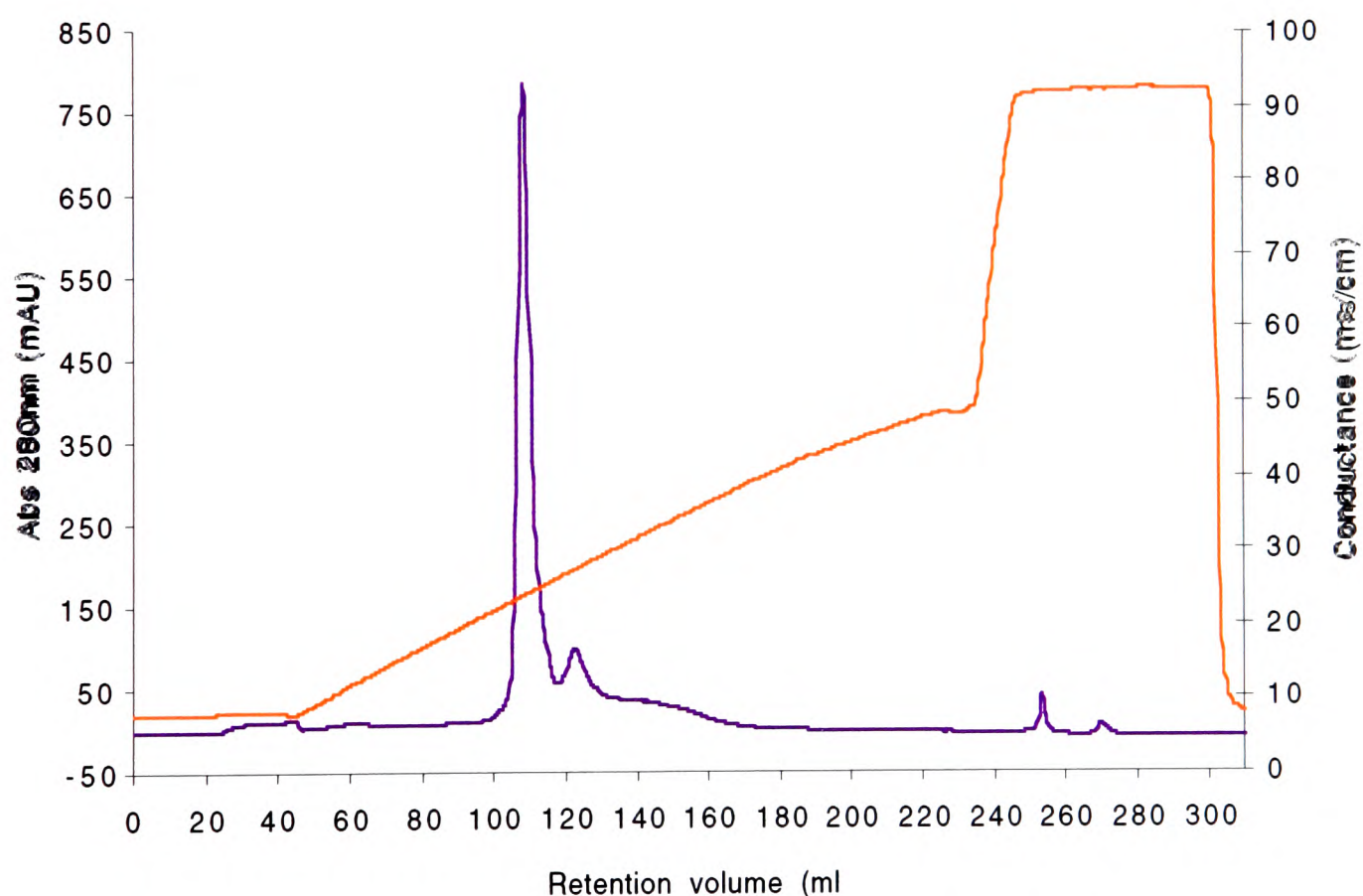

Figure 3-7: Elution profile of the rBC(N/CRD) on Q-Sepharose column. 20ml of dialysed, partially purified rBC(N/CRD) solution was diluted to 50ml with double distilled water and was loaded onto the column through a 50ml superloop. A linear gradient 0-50% bufferB was applied for 90min followed by a steep linear gradient of 50-100% bufferB for 5min. The recombinant protein eluted at approximately 200mM salt concentration.

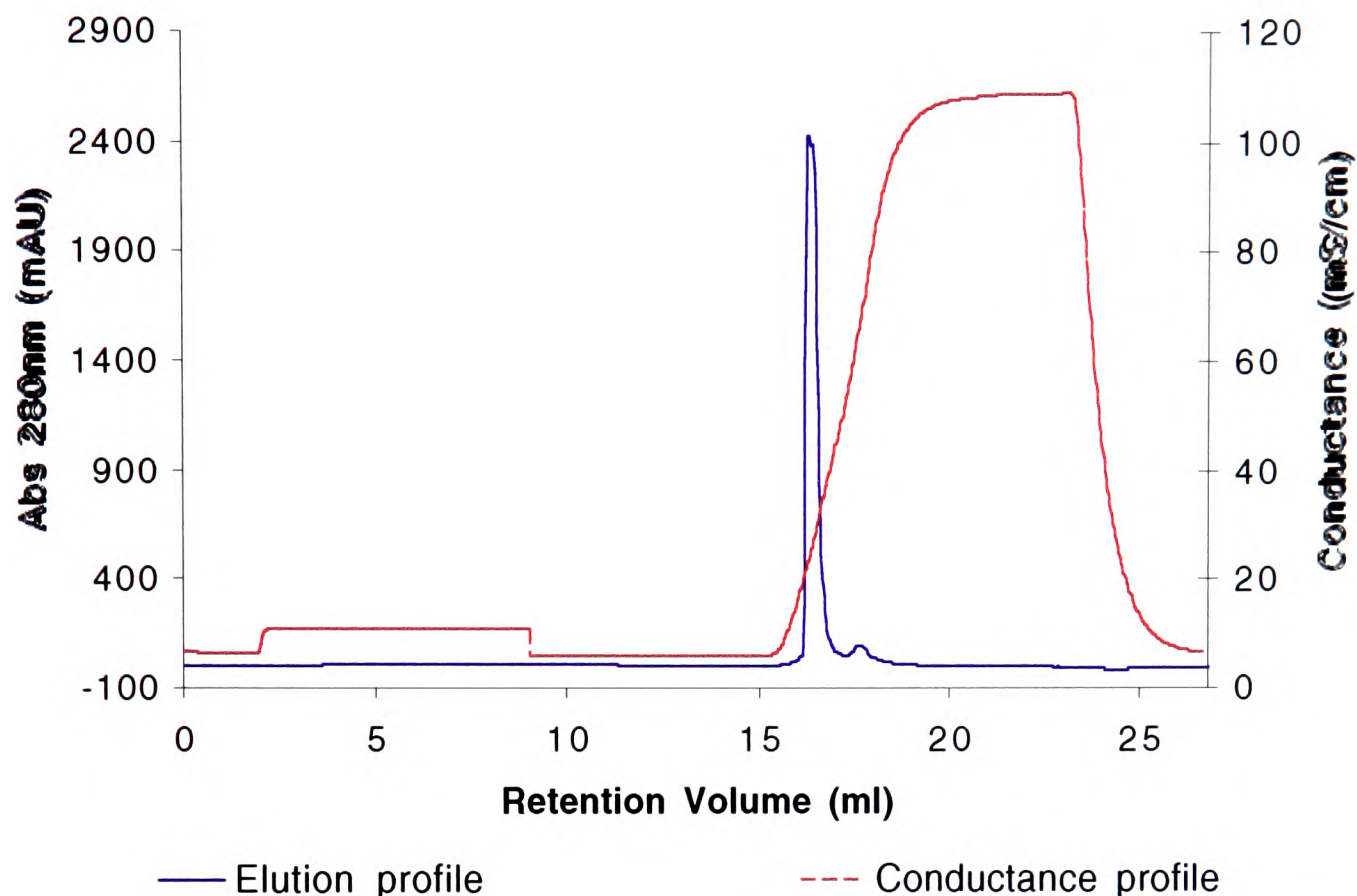

Figure 3-8: Elution profile of the recombinant BC(N/CRD) on Mono-Q column.

10ml of the sample from Q-sepharose, diluted to 50ml, was loaded onto the column through a 50ml superloop at a flowrate of 1ml/min. A steep linear gradient 0-100% buffer B was applied over 5min. The concentrated protein eluted as a single peak at approximately 200mM salt concentration.

3.4 BIOCHEMICAL CHARACTERISATION

3.4.1 MOLECULAR SIZE

The molecular size of the recombinant BC(N/CRD), under non-dissociating conditions was determined by gel filtration. The protein sample was loaded onto the Superose-12 or Superdex-75 column, at room temperature and eluted with calcium or EDTA containing Tris-buffer (as described in section 3.3.1.3). The recombinant protein eluted as a single major peak corresponding to

3.3.1.3). The recombinant protein eluted as a single major peak corresponding to 64kDa, which indicated the trimeric nature of recombinant conglutinin (Figure 3-9). A small peak before the main peak suggests a possible dimerisation.

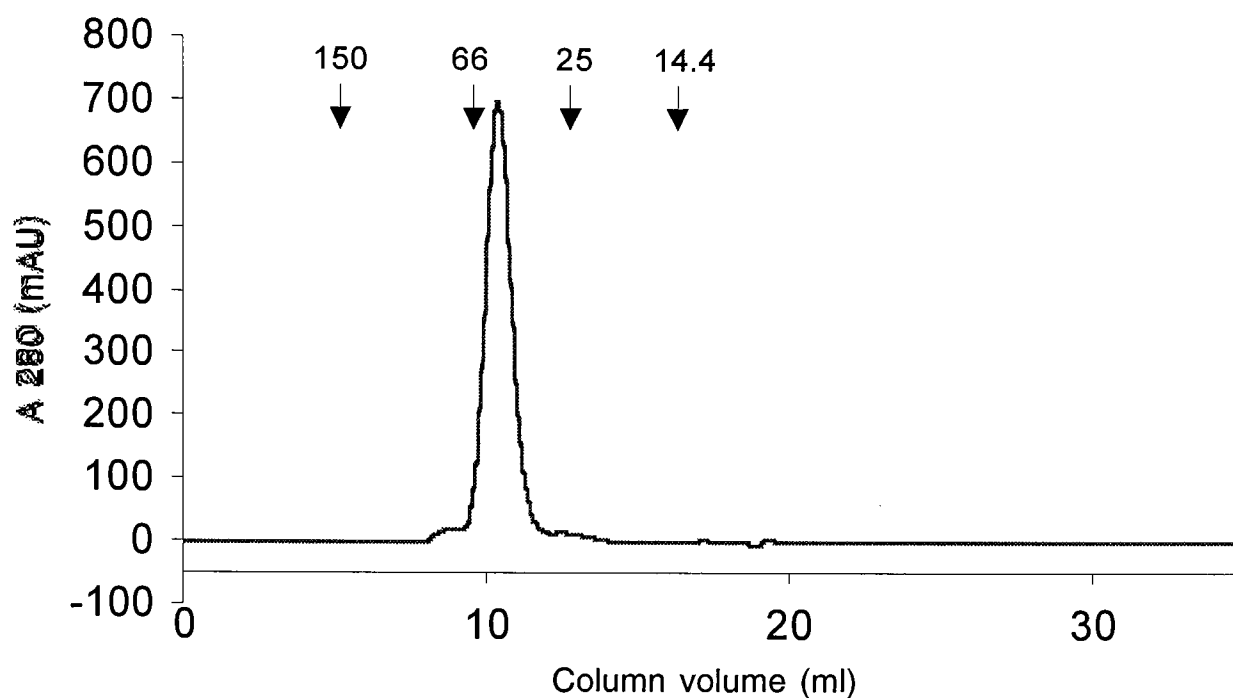

Figure 3-9: Gel-filtration chromatography elution profile of rBC(N/CRD).

200µl of protein sample (peak fractions from Mono-Q) was loaded onto Superdex75 gel-filtration column, in tris buffer containing calcium or EDTA. The column was run at a flowrate of 1ml/min and the samples collected as 0.5ml volume fractions. The absorbance was read at 280nm, 260nm (not shown) and 225nm (not shown). The column was calibrated using the following molecular weight standards (positions shown on the profile): Alcohol dehydrogenase (150kDa), BSA (66kDa), Carbonic Anhydrase (29kDa) and Cytochrome C (14.4kDa).

3.4.2 HPLC

The purity of the protein was further assessed on reverse phase HPLC column (as described in section 2.9.3). The column was run in acetonitrile buffer and a linear gradient applied over 50min. The elution profile (Figure 3-10) of the recombinant trimeric BC revealed four peaks.

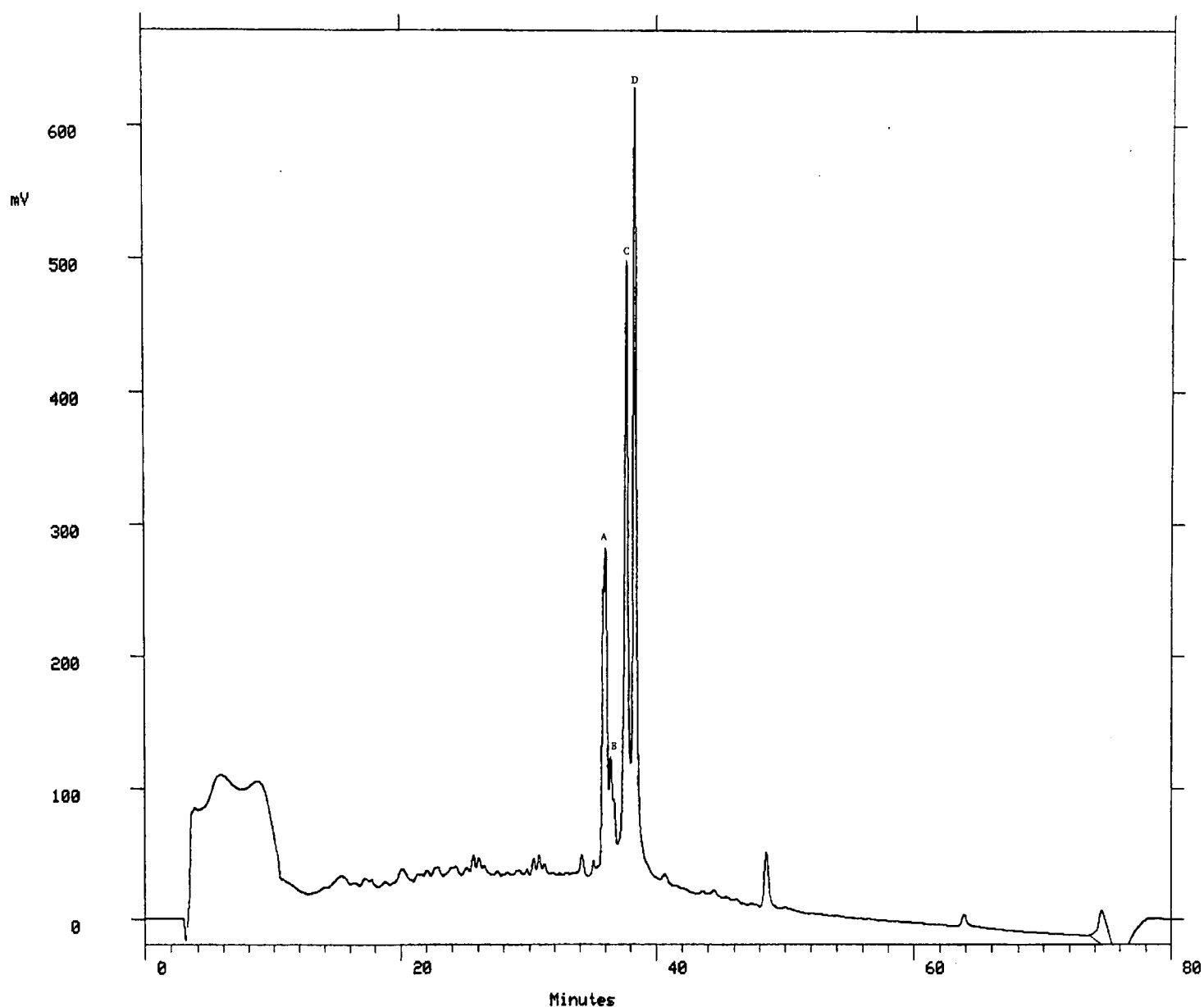

Figure 3-10: HPLC profile of recombinant fragment of Bovine Conglutinin. The protein sample was equilibrated with 0.1% (v/v) trifluoroacetic acid/2% (v/v) acetonitrile. A linear gradient 2-50% (v/v) acetonitrile was applied over 50min followed by a linear gradient of 50-90% (v/v) acetonitrile for 18min. the elution profile revealed four peaks which were analysed by mass spectrometry.

3.4.3 MASS SPECTROMETRY

The molecular mass of the HPLC peaks was determined using electron spray mass-spectrometry ([Figure 3-11](#)). The first two peaks were found to be contaminants in the sample. The other two peaks revealed a difference in their mol. wt. of four daltons. This difference is probably due to reduction of the disulphide groups.

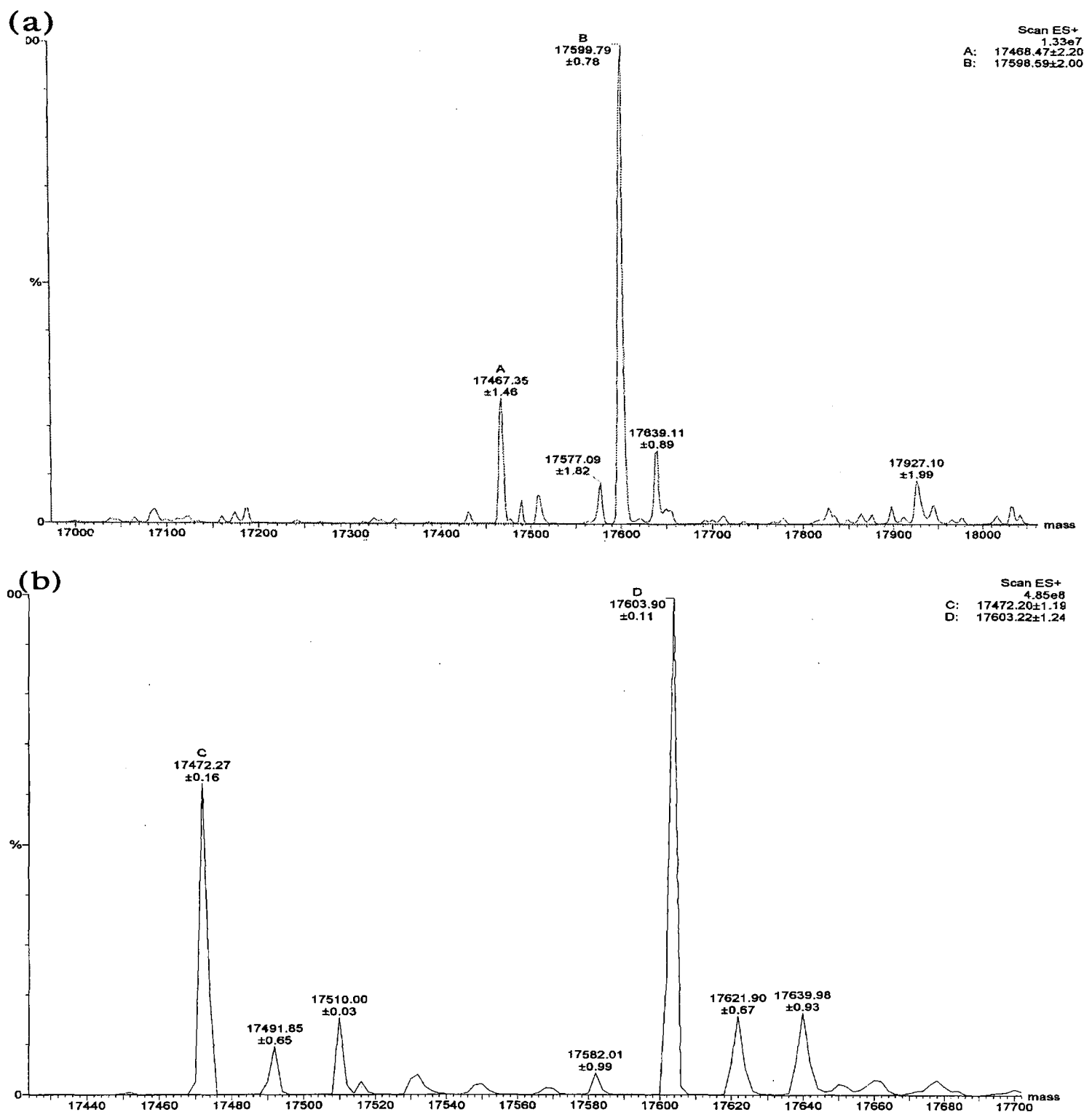

Figure 3-11: Mass spectrometric analysis of the HPLC peaks C&D.

The four peaks obtained from the HPLC profile of recombinant conglutinin were analysed by electron spray mass-spectrometer. The samples were adjusted to approximately 25picomoles/ μ l protein in 50% (v/v) acetonitrile, 1% formic acid. Peaks A & B were found to be contaminants. (a) mass-spec. profile of peak C and (b) mass-spec. profile of peak D.

The mass (Da) of the peaks:

Peak C: 17599

Peak D: 17472 and 17603

3.4.4 N-TERMINAL SEQUENCING

The N-terminal region of recombinant conglutinin was analysed up to 40 amino acid residues. The sequence obtained is as follows:

GSAEANALKQRVTILDGHLRRFQNAFSQYKKAVLFPDGQA

This is in agreement with the published sequence in the protein database except for the underlined residue. The sequence showed alanine as compared to valine in the database sequence. This aberration was traced to the PCR based cloning (*Wang et al.*, 1995) of the recombinant protein from the initial cDNA clone (*Lu et al.*, 1993) from which the present recombinant fragment has been derived.

3.5 FUNCTIONAL CHARACTERISATION

3.5.1 BIA ANALYSIS OF THE GEL-FILTRATION FRACTIONS.

The peak fractions containing the recombinant conglutinin eluted from Superdex75 column were assessed by BIAcore for functional activity on a biotinylated-mannan bound to the sensor chip CM5. 10µl of each fraction was diluted to 50 µl with HBS buffer. A seven minutes pulse of each fraction was injected into the flow cell at a flow rate of 5µl/min. The binding was recorded as response units against time and evaluated by 'BIAevaluation 3.0' (BIAcore® systems) software.

3.5.2 SOLID PHASE CARBOHYDRATE BINDING ASSAY

Sugar binding affinity of the recombinant and native conglutinin was assessed by indirect ELISA on Nunc® Immuno maxisorp 96-well plates. The wells were coated with 10µg of mannan or BSA-conjugated GlcNAc (Sigma Chemicals),

in carbonate-bicarbonate buffer (pH 9.6) and left overnight at 4°C. The wells were blocked with 2% (w/v) BSA in TBS/C at 37°C for 1 hr. The lectins; native and recombinant concglutinin were added to the wells at varying concentrations, diluted in TBS/C and incubated for 2 hrs at 37°C. Rabbit anti-BC antibody was added to the wells at a dilution of 1:2000 and incubated for 1 hr at 37°C. Peroxidase conjugated goat anti-rabbit anti-IgG (Sigma Chemicals) was then added to the wells at a dilution of 1:2000 and incubated at 37°C for 1hr. The wells were washed between each incubation with TBS/C buffer containing 0.05% (v/v) Tween-20. The plates were developed by adding 100µl of TMB peroxidase substrate (BioRad) for 5-10mins. The reaction was stopped with 50µl/well of 2N H₂SO₄ and the absorbance read at 450nm on Microtek microtitre plate reader.

For EDTA inhibition assays, the dilution and wash buffers contained 10mM EDTA. Similar protocol was used for sugar inhibition studies. However, the lectins were incubated with sugars for 30mins before adding on to the sugar coated plates.

3.5.3 BIOTINYLATION

A modified protocol (*Ghebrehiwet et al.*, 1988) was used for biotinylating recombinant concglutinin. Recombinant protein at a concentration of 1mg/ml (in TBS) was dialysed against carbonate buffer (pH 8.3), in a Pierce Slide-A-lyzer™ cassette (MWCO 30K), for 12-16 hrs at 4°C with three buffer changes. The dialysed protein in 1ml volume was incubated with 50µl of NHS-SS biotin (10mg/ml) freshly dissolved in dimethyl sulphoxide (DMSO) on an end to end shaker for four hours at room temperature. The molar ratio of biotin (Mol. wt. 66

Da) to BC used was 50:1. The reaction mixture was then dialysed for 24-48 hours in Tris-buffered Saline (pH 7.5) at 4°C. The biological activity of the biotinylated protein was assessed by ELISA, using Streptavidin-peroxidase as a probe.

The efficiency of the biotinylation was assayed by ELISA. The extent of biotinylation was determined by coating serially diluted biotinylated-rBC onto the 96-well plate, in carbonate buffer and incubated overnight at 4°C. The wells were blocked with 1% (w/v) milk and 0.15% (w/v) glycine, dissolved in water, at 37°C for 1 hour. Streptavidin-peroxidase conjugate at varying dilutions were added and incubated for 1 hour. Biotinylated-rBC was also tested against varying dilutions of rabbit anti-BC antibody. The plates were developed with TMB-peroxidase substrate and the reaction stopped with 2N H₂SO₄.

3.5.4 RESULTS

3.5.4.1 BIAANALYSIS

The functional activity of gel-filtration purified recombinant protein was assessed by BIAcore. The fractions were injected into the flow cell over sensor surface coated with biotinylated mannan. The peak fraction (fractions 20-22) showed high and specific binding to the mannan coated on sensor chip SA.

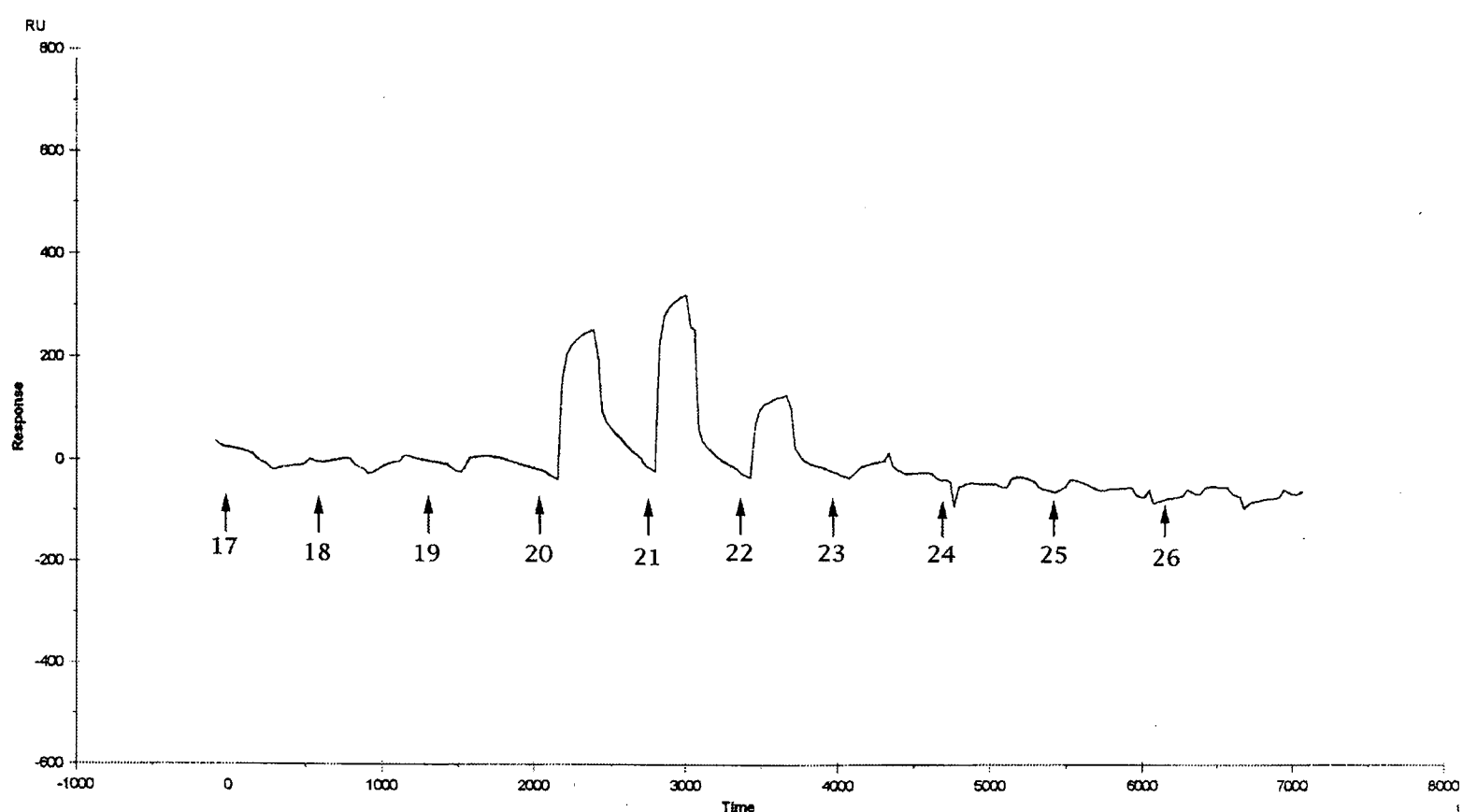

Figure 3-12: BIA analysis of the Superdex75 fractions.

Fraction samples from superdex75 column were injected into the flow cell over the biotinylated-mannan coated sensor chip SA. The arrowheads represent the point of injection of each fraction.

3.5.4.2 CARBOHYDRATE BINDING ASSAY

Binding affinity of recombinant conglutinin for solid-phase GlcNAc and mannan, was assessed in comparison with the native molecule. rBC(N/CRD) showed a linear binding relationship to increasing concentration of the mannan (Figure 3-13) and GlcNAc (Figure 3-14). The binding of recombinant conglutinin was lower than that of the native molecule. Native conglutinin is a tetramer of trimeric heads and would thus exhibit a greater affinity as compared to recombinant molecule, which consists of trimeric heads only.

The binding of conglutinin to immobilised GlcNAc was inhibited by incubating lectins with the sugar (Figure 3-15). The binding of rBC to GlcNAc was also lowered by the presence of EDTA (10mM) in the (Figure 3-13 & Figure 3-14).

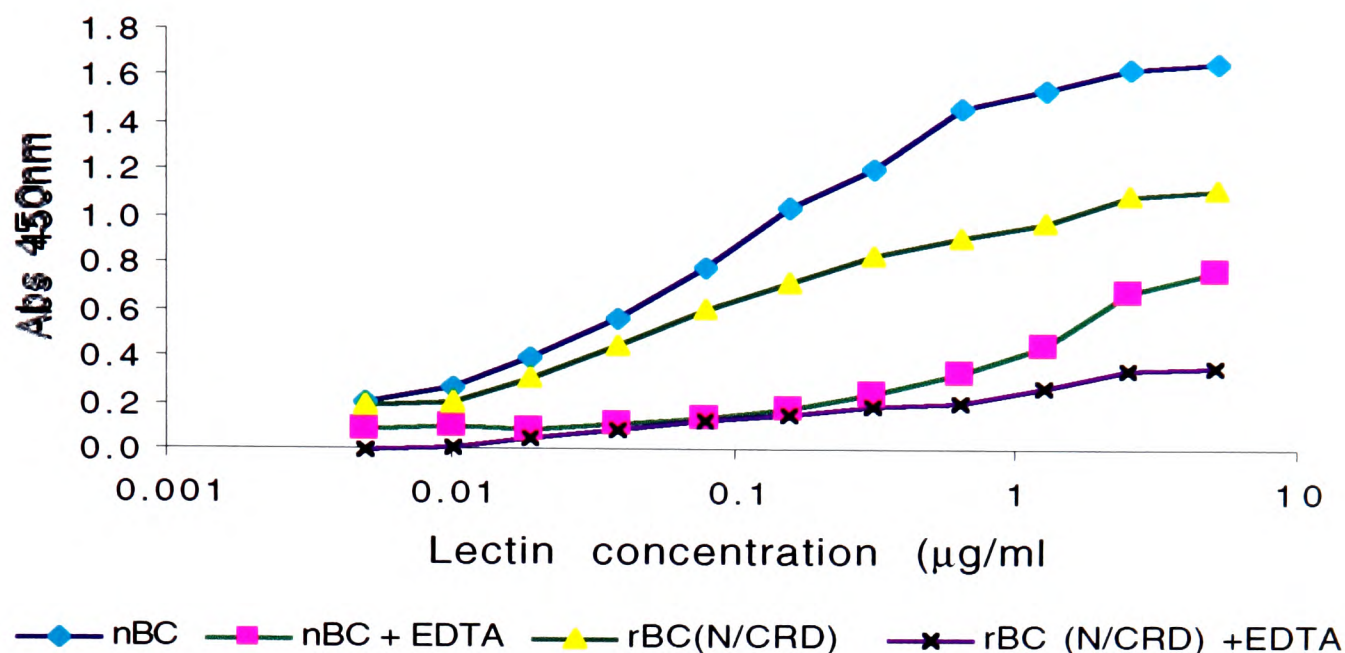

Figure 3-13: Binding of conglutinin to solid-phase mannan.

The native and recombinant conglutinin to varying concentrations of solid phase mannan coated onto Nunc® Immuno maxisorp 96-well plates. The binding of rBC(N/CRD) was lower as compared to the native molecule. The ELISA was carried out in tris buffer containing 5mM CaCl₂ and the reaction was developed with TMB-peroxidase.

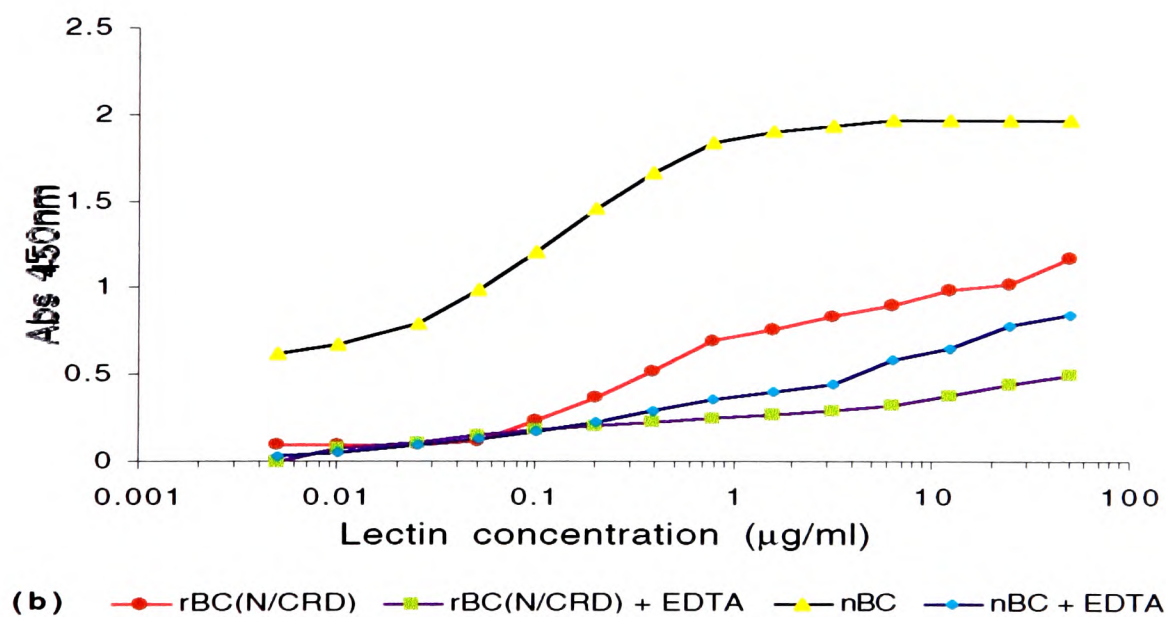

Figure 3-14: Binding to solid-phase N-acetyl glucosamine

BSA-conjugated N-acetyl glucosamine was coated onto maxisorp plates at varying concentrations. Native and recombinant conglutinin were added at concentrations of 1µg/ml and 10µg/ml, respectively. The binding of rBC(N/CRD) to solid phase GlcNAc was lower as compared to the native molecule. The ELISA was carried out in tris buffer containing 5mM CaCl₂ and the reaction was developed with TMB-peroxidase.

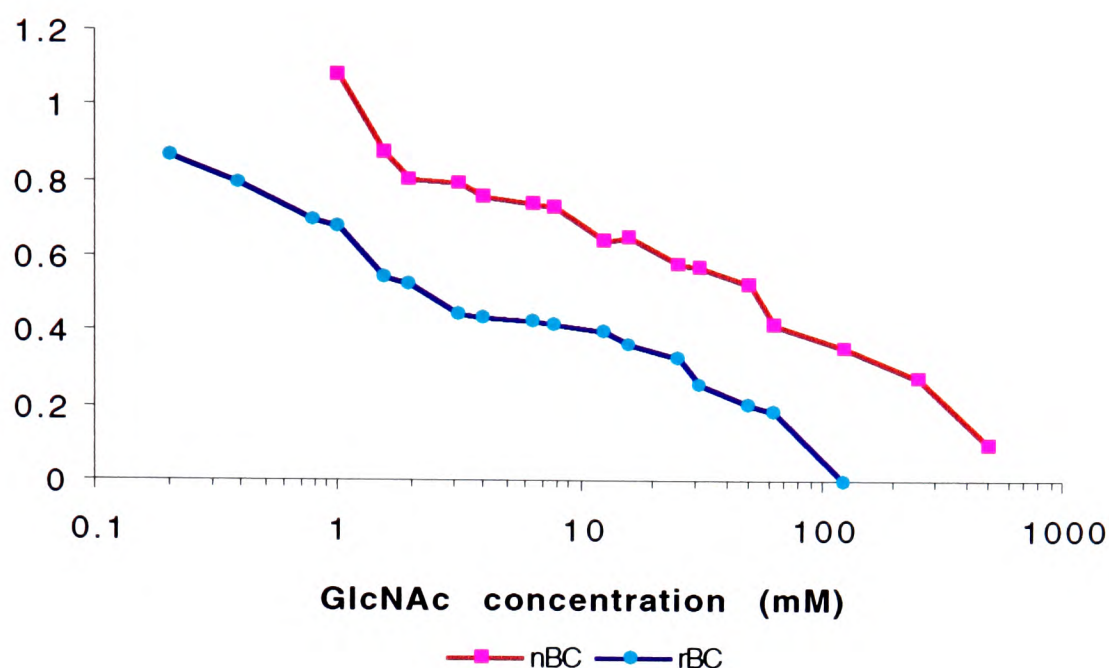

Figure 3-15: Competitive inhibition of binding by N-acetyl glucosamine. 10 μ g of BSA-conjugated N-acetyl glucosamine was coated onto maxisorp plates. The lectins; native and recombinant conglutinin were added at concentrations of 1 μ g/ml and 10 μ g/ml respectively. The inhibition of binding of the lectins to GlcNAc was assayed varying concentration of fluid-phase competing GlcNAc.

3.5.4.3 BIOTINYLATION

The efficiency of biotinylation was estimated by an ELISA based assay. Various concentrations of the biotinylated rBC (biotin-rBC) was coated on a 96-well plate. The wells were then incubated with various dilution of streptavidin-peroxidase conjugate ([Figure 3-16](#)) and anti-BC antibody (followed by anti-IgG-peroxidase conjugate). Streptavidin was able to recognise the b-rBC at much lower concentration than the anti-BC antibody, suggesting the biotinylated protein-streptavidin as a more sensitive assay.

However, biotin-rBC showed very low binding to GlcNAc (data not shown), suggesting a possible alteration of the sugar binding site by biotin. Biotinylated rBC was tested for its ability to retain its affinity for carbohydrates. Varying dilutions of b-rBC were incubated with solid-phase N-acetyl glucosamine

(10 μ g/ml) and detected with rabbit anti-BC and streptavidin-peroxidase conjugate and the plate developed after one hour of incubation, as described above.

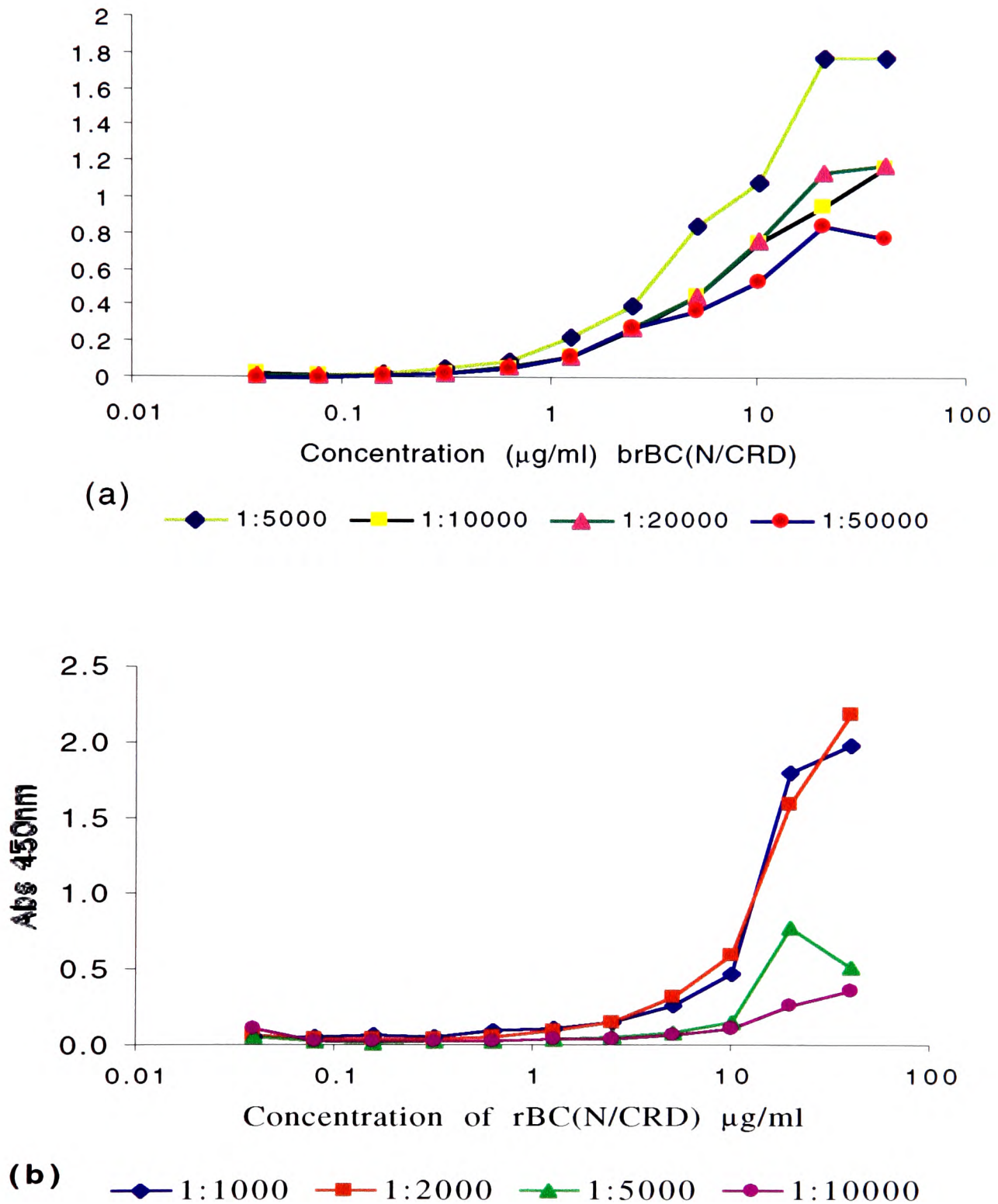

Figure 3-16: Assessment of carbohydrate-binding property of biotinylated rBC(N/CRD).

(a) Binding of anti-BC antibody, at various dilutions to varying concentrations of rBC(N/BC) immobilised on the maxisorp plate. (b) Binding of streptavidin, at various dilutions to varying concentrations of biotinylated rBC(N/CRD) immobilised on Nunc® maxisorp plates.

3.5.5 BIA ANALYSIS OF INTERACTION

The binding affinity of the recombinant conglutinin comprising neck and CRD regions to mannan and iC3b was estimated using BIAcore system. The dissociation constants for each interaction were calculated and the inhibition of binding by various sugars was also analysed.

3.5.5.1 METHODOLOGY

Biotinylated mannan (1.35ng/ml) was immobilised onto a Streptavidin chip SA (described in section 2.10.5.3). Sensor chip CM5 was used to immobilise complement component iC3b using ligand-thiol coupling chemistry (described in section 2.10.5.2). Native and recombinant BC, at various dilutions in Tris buffer (10mM Tris-Cl pH 7.4, 150mM NaCl, 5mM CaCl₂) were then injected at a flow rate of 5µl/min as a 4-min pulse. The interaction was stopped by injecting a 2-min pulse of Tris-buffer containing 10mM EDTA (pH 9.0). The interactions were recorded and analysed using 'BIAevaluation 3.0' software.

3.5.5.2 PROCEDURE SUMMARY:

- | | |
|---|--------------------|
| (a) Continuous flow buffer | Flow rate 5µl/min |
| (b) Tris buffer (10mM EDTA) pH 9.0 | Inject 10µl (2min) |
| (c) Lectin (5mM CaCl ₂)pH 7.4 | Inject 20µl (4min) |
| (d) Tris buffer (10mM EDTA) pH 9.0 | Inject 10µl (2min) |

Steps (c) and (d) were repeated till the end of the procedure.

3.5.5.3 BIAANALYSIS

3.5.5.3.1 BINDING TO MANNAN

Biotinylated-mannan was immobilised on Streptavidin-coated chip SA5. Various dilutions of native and recombinant conglutinin were injected into the flow cell. A steep binding followed by a slow association curve was observed when the lectins were injected. The protein showed a fast dissociation followed by slow dissociation curve. This suggested that there were a combination of interactions due to the binding of the multivalent large molecular structure of the protein to closely-spaced sugar moieties (*van der Merwe and Barclay, 1996*). This could possible be a result of a 'bulk effect'. For the calculation of dissociation constant the steep component of the response curves were excluded and the slow curves associated with specific binding were used. The dissociation constant for the interaction was calculated as 0.6 μ M (Figure 3-17, a&b).

The competitive inhibition of the binding of rBC(N/CRD) to mannan by various sugars was also assessed. N-acetyl glucosamine was the most efficient inhibitor of the interaction, as compared to other sugar residues tested, and was able to inhibit the binding at 5mM concentration (Figure 3-17 c).

3.5.5.3.2 BINDING TO IC3b

Complement component, iC3b was immobilised on the sensor chip CM5. Recombinant conglutinin was added at various concentrations in Tris buffer. The protein showed specific binding with slow association and dissociation curves. The dissociation constant calculated for the interaction was 2.4 μ M (Figure 3-18 a&b).

Inhibition of binding of rBC(N/CRD) to iC3b by competing sugars was also analysed. N-acetyl glucosamine was most efficient in inhibiting the binding of recombinant conglutinin to iC3b (Figure 3-18 c).

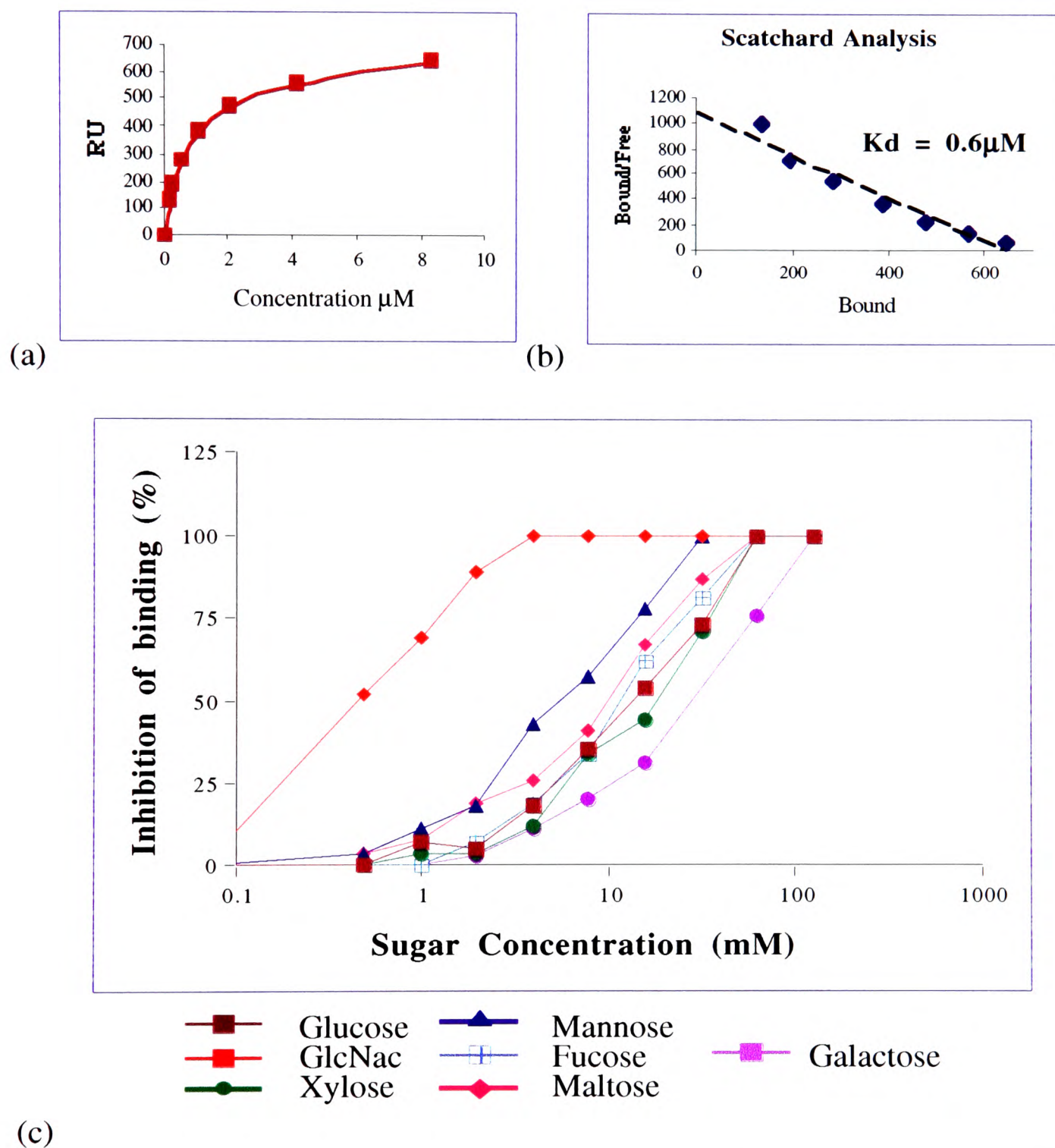

Figure 3-17: BIA analysis of interaction of recombinant conglutinin fragment, comprising of neck and CRD, with Mannan.

(a) **Binding kinetics;** Affinity of rBC(N/CRD) binding to immobilised biotinylated mannan. (b) **Scatchard Analysis;** plot of the specific binding of rBC(N/CRD) to mannan. The dissociation constant (K_d) for the interaction was calculated as $0.6\mu\text{M}$.

(c) **Competitive kinetics;** Inhibition of rBC(N/CRD) binding to biotinylated mannan, immobilised on sensor chip SA, by various sugar residues. Inhibition of the binding by N-acetyl Glucosamine was highest among the various sugar residues tested.

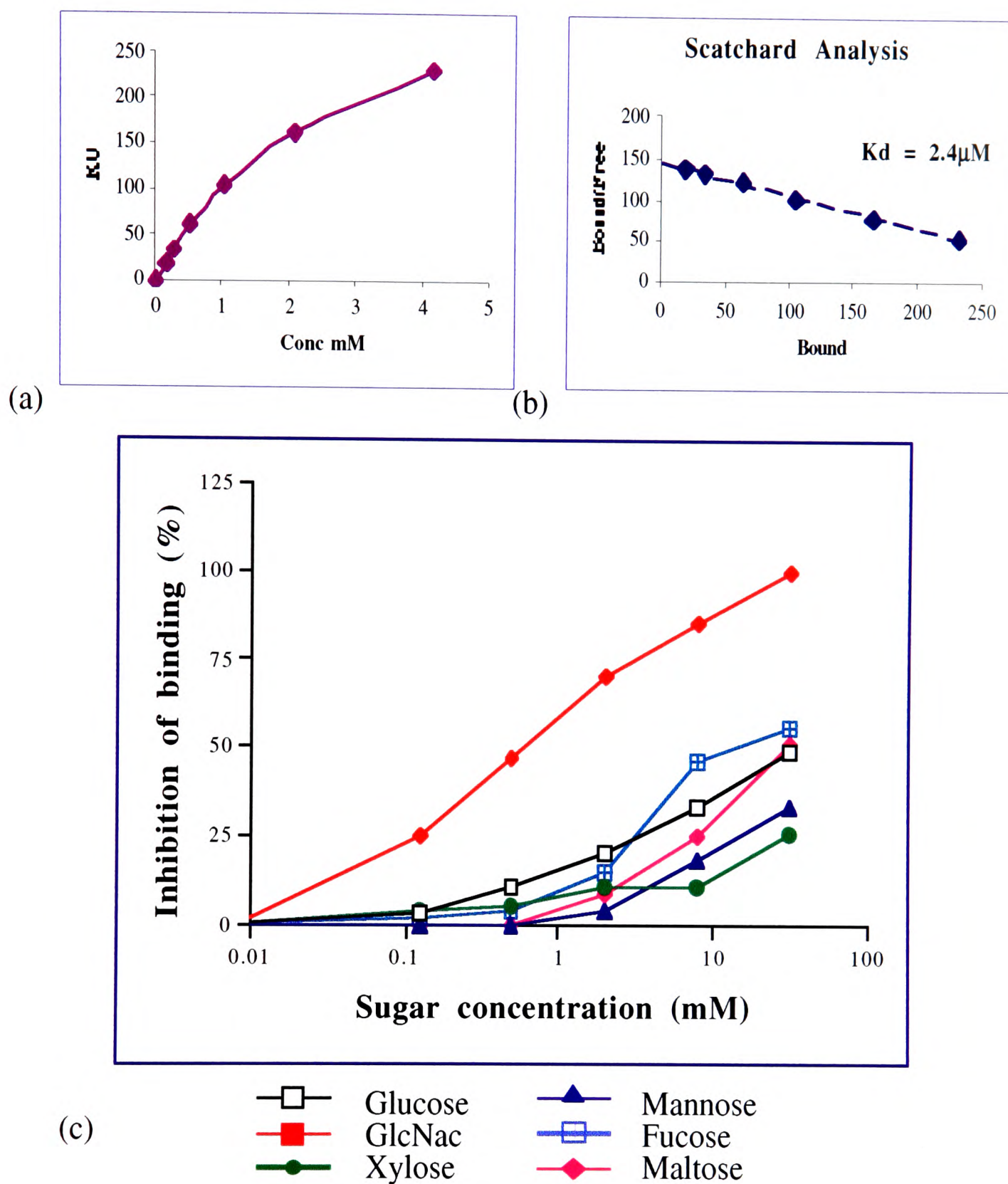

Figure 3-18: BIA analysis of interaction of recombinant Conglutinin fragment, comprising of neck and CRD, complement component iC3b.

(a) **Binding kinetics;** Affinity of rBC(N/CRD) binding to immobilised iC3b. (b) **Scatchard Analysis;** plot of the specific binding of rBC(N/CRD) to complement component, iC3b. The dissociation constant(K_d) for the interaction was calculated as $2.4\mu\text{M}$. (c) **Competitive kinetics;** Inhibition of rBC(N/CRD) binding to iC3b, immobilised on sensor chip CM5, by various sugar residues. Inhibition of the binding by N-acetyl Glucosamine was highest among the various sugar residues tested.

3.6 BINDING TO LIPOPOLYSACCHARIDES

3.6.1 METHOD

The LPS obtained from gram negative bacteria, *Pseudomonas aerogenosa*, *Salmonella typhosa* and *Klebseilla pnemonieae* (Sigma Chemicals) were suspended in Sodium Barbitol Buffer (pH 4.66). The LPS solution was warmed to 37°C for 5min and sonicated in ultrasonic bath (Mettler Electronics) for 5 min to get a homogenous solution. The LPS was coated onto 96-well Immulon 1B (Dynex Technologies Inc, USA) at a concentration of 80µg/ml and left overnight at 4°C. The lectins; native conglutinin and SP-D and recombinant conglutinin were added at a concentration of 1µg/ml for native proteins and 10µg/ml for recombinant BC. The plates were incubated at 37°C for 90 min. The wells were then incubated with 100µl of 1:2000 dilution of rabbit anti-BC or anti-SP-D antibodies for 1hr at 37°C. Goat anti-rabbit IgG conjugated to alkaline phosphatase was added to the wells at a dilution of 1:2000 and incubated further for 1 hr. The plates were developed by adding 200µl of p-Nitrophenyl phosphate (Sigma Fast™ tablet) in Tris buffer and incubated at RT for 30min. The absorbance was recorded at 405nm on Microtek microtitre plate reader.

The binding was also assessed in presence of EDTA and competing sugars, GlcNAc and maltose. The lectins and the antibodies were diluted in Dulbecco's PBS with calcium (Sigma Chemicals). The plates were washed between steps of adding lectin and antibodies in Dulbecco's PBS without calcium containing 0.1% (v/v) Tween-20. The assay was performed in triplicates and repeated twice.

3.6.2 RESULTS

The ability of native and recombinant conglutinin to bind LPS from gram-negative bacteria *Klebsiella pneumoniae*, *Pseudomonas aerogenosa*, and *Salmonella typhosa* was assessed by ELISA. Native SP-D was used as positive control, which showed high binding to all the three LPS. The binding was calcium dependent and inhibitable by competing sugars maltose and GlcNAc. Native and recombinant conglutinin showed calcium-dependent binding to the LPS (Figure 3-19). The binding, however, was lower than that observed for hSP-D. The recombinant conglutinin showed lower binding than native molecule. The binding was inhibited in presence of sugar residues, 10mM GlcNAc and 100mM maltose. The antibodies used in this assay are polyclonal anti-BC and anti-SPD. A control to test the binding to LOS was not included during the assay and needs to be checked.

(a) *Klebsiella pneumoniae*

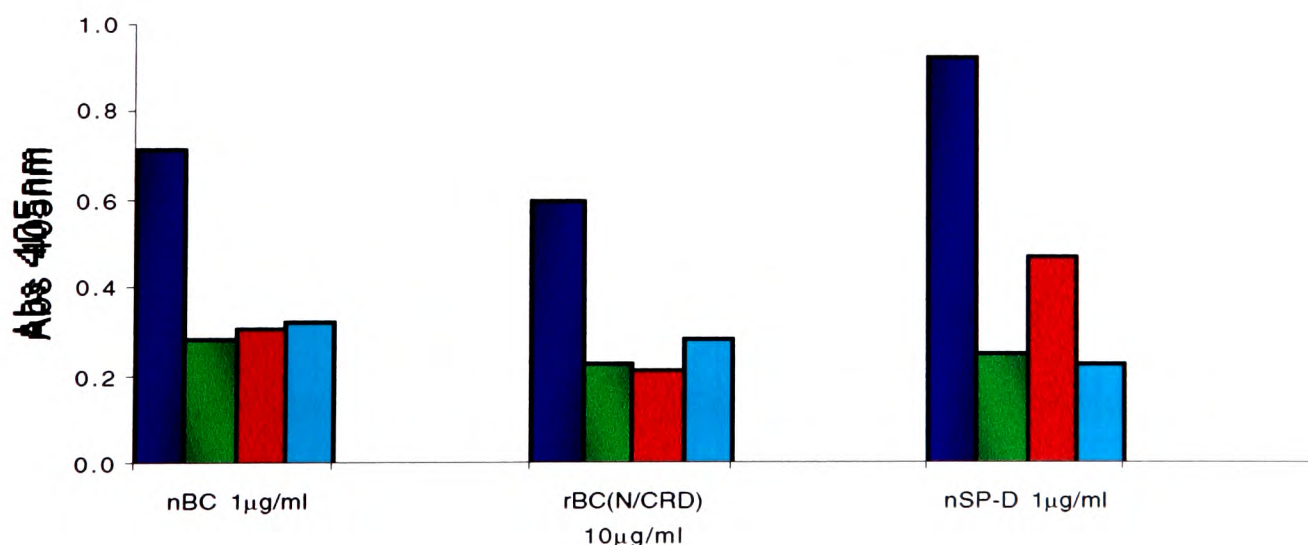

(b) *Pseudomonas aeruginosa*

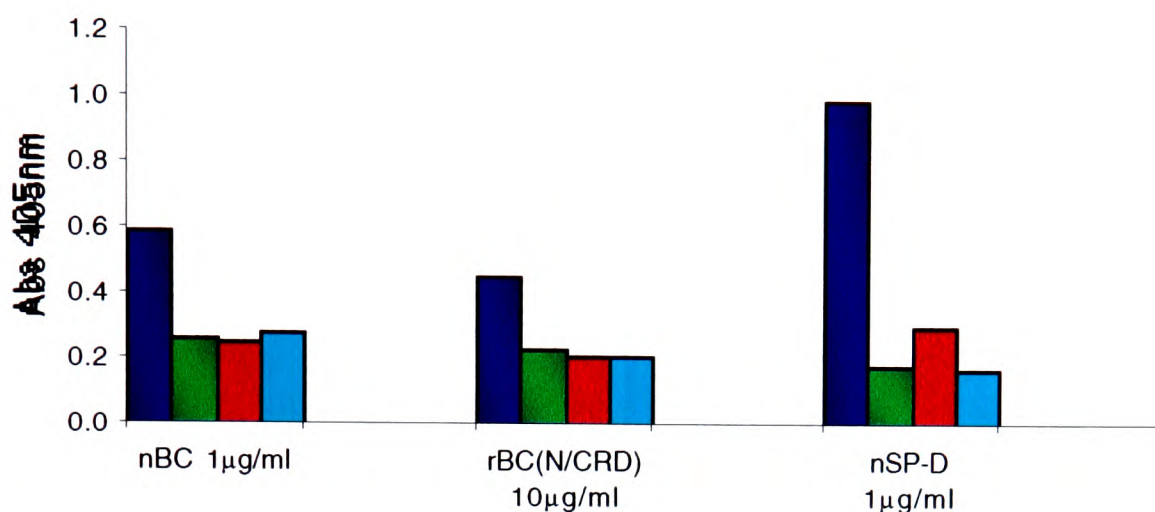

(c) *Salmonella typhosa*

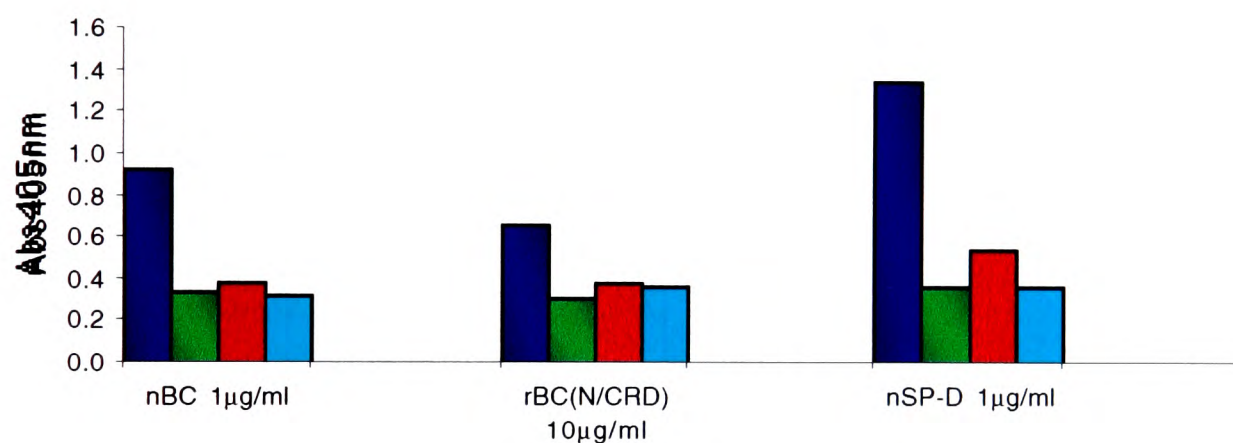

Figure 3-19: Binding to LPS from gram-negative bacteria by Conglutinin.

LPS obtained from (a) *Klebsiella pneumoniae*, (b) *Pseudomonas aeruginosa* and (c) *Salmonella typhosa* were plated onto 96-well Immulon-1B plate. (■ lectin in calcium buffer ■ lectin in EDTA, ■ lectin with 50mM GlcNAc and ■ lectin with 100mM maltose).

3.7 CRYSTALLISATION STUDIES

The essential feature of a crystal is its ordered and 3-dimensionally periodic internal structure. The most critical step in determining the three dimensional structure of the protein, by the single crystal X-ray diffraction method is obtaining large single crystals suitable for diffraction studies. The objective in crystallising a protein is to gradually force the macromolecule from the solution,

done by the precipitants which fall into three main categories: salts such as ammonium sulphate; organic solvents such as ethanol and polyethylene glycols.

The most common method for crystallising proteins is the hanging drop method. A small drop of the sample mixed with crystallisation reagent is suspended from a siliconised glass slide inverted over a larger reservoir containing the buffer. The wells are then sealed with silicone grease and allow the chamber to be saturated with the crystallisation reagent. Once the vapour equilibrium is reached, the protein either precipitates or remains in solution. If the crystallisation conditions are optimal, the protein molecules arrange in defined lattice, thereby entering crystalline phase. The hanging drop method has been used in the present study.

3.7.1 CRYSTALLISATION TRIALS OF rBC

The protein was concentrated using Millipore concentrators (30K MWCO) to a concentration of 5mg/ml. 2 μ l of the concentrated protein in buffer containing 25mM Tris-Cl (pH 7.5), 0.4M NaCl and 20mM CaCl₂, placed on a clean coverslip, was mixed with 2 μ l of the well buffers. The coverslip was inverted and the well was sealed and left at constant temperature (25°C). Crystal Screen systems I and II (Hamilton Research) were used to standardise the initial crystallisation conditions. Further favourable conditions were examined with varying concentrations of PEG-1500 and calcium.

Preliminary crystals have been obtained in the conditions: 0.1M Tris (pH 7.5), 0.4 M NaCl, 20mM CaCl₂ and 30% (w/v) PEG-1500. The crystals obtained (Figure 3-20) were birefringent but diffracted to only 6Å. The crystallisation

conditions are being improved to obtain better crystal that would diffract to higher resolution.

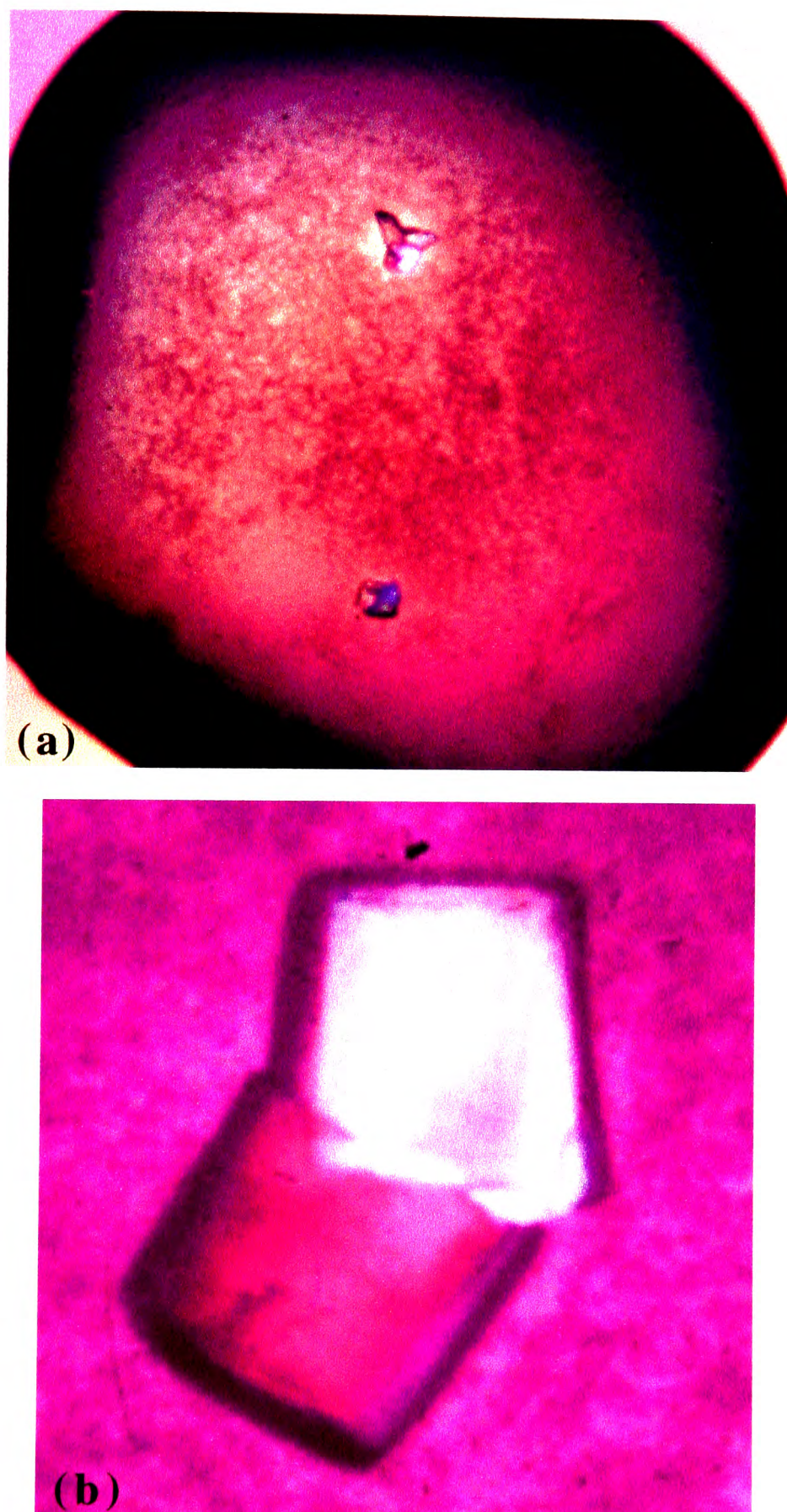

Figure 3-20: Crystals of the recombinant Bovine Conglutinin. Recombinant conglutinin, rBC(N/CRD) at a concentration of 5mg/ml was used in crystallisation trials. These crystals were obtained in the following buffer conditions: 0.1M tris (pH 7.5), 0.4M NaCl, 0.02M CaCl₂ and 30% (w/v) PEG1500. The crystals diffracted to 6Å. The crystallisation conditions are being refined to obtain larger crystals for X-ray diffraction analysis.

3.8 SUMMARY

In this study, a polypeptide comprising the CRD and neck regions of bovine conglutinin have been expressed in the *E.coli* strain BL21(DE3)pLysS. The protein was purified by using a denaturation-refolding procedure. The recombinant protein, lacking the N-terminal and collagen-like region was found to assemble as a homotrimer as determined by FPLC.

Molecular weight analysis of the recombinant fragment revealed a discrepancy in the molecular weight of rBC(N/CRD) as observed by different methods *viz.* FPLC and mass spectrometry. Molecular mass (Da) of recombinant conglutinin determined by different techniques:

(e) Amino acid sequence (Figure 1-9)		17328
Mass Spectrometry (Figure 3-11)	Peak C	17599
	Peak D	17427 17603

The difference between the two HPLC peaks C and D was four daltons, suggesting peak C to be the unreduced fraction and the Peak D consisting of reduced disulphide bonds. Two peaks were seen in the peak D with a difference in mass of 176 Da, that corresponds to a methionine residue. It is likely that the removal of methionine from the nascent protein was not effectively removed by the enzyme, due to high levels of expression of the target protein. However, another discrepancy was observed *i.e.* that the mass of the fragment as determined by amino acid sequence (17328) was lower than that observed by the mass

spectrometry. The difference suggested the presence of an extra phenylalanine residue in the recombinant material. The N-terminal of the protein was clean as determined by sequencing and therefore it is possible there might be an insertion of the Phe residue at the C-terminus of the protein. Unfortunately, data is not available to confirm these suggestions.

The sugar binding affinities of native conglutinin and the recombinant fragment of conglutinin were assessed by a solid-phase carbohydrate-binding assay. The studies indicate the ability of the recombinant conglutinin to retain its sugar binding affinity, albeit at a lower level than that of the native molecule which is a tetramer of trimeric heads. The binding is calcium-dependent and is inhibited in the presence of competing sugars and EDTA. An attempt was made to biotinylate the protein but this procedure abrogated the sugar binding of the protein, probably due to biotinylation of the residues involved in sugar binding.

The dissociation constants for the binding of rBC(N/CRD) to mannan and to iC3b fragment of the complement component C3 were determined by BIAcore to be 0.6 μ M and 2.4 μ M respectively. On testing the inhibitory effect of various sugars on the binding of rBC(N/CRD) of conglutinin to mannan and iC3b, N-acetyl glucosamine was found to be more effective than the other sugars tested. Both rBC(N/CRD) and nBC bound to the LPS derived from gram negative bacteria. However, the binding observed was much lower than that of native SP-D.

To define the functional properties of the recombinant conglutinin based on structural features, attempts were made to crystallise the protein. Preliminary crystals of the recombinant protein have been obtained which diffract to low

resolution. The crystallisation conditions are being further refined to obtain larger and better diffracting crystals.

3.9 DISCUSSION

Conglutinin belongs to the family of collectins characterised by four domains: a cysteine-rich N-terminus, a collagen-like region linked to a CRD through an α -helical coiled-coil neck region. BC has been shown to bind various microorganisms which is mediated by recognising the terminal sugar residues on the microbial surface. The clustered C-type lectin domains of collectins, by binding to the carbohydrate ligands on the cell-surfaces of pathogens, fulfils a recognition function which then can elicit effector functions via the collagen-like region, such as complement activation (in case of MBP) or binding to cell-surface receptors to trigger cell-mediate killing. The sugar specificity of the collectins is defined by the residues in the binding site of the trimeric CRD. To further elaborate the structure/function relationship of BC, a recombinant fragment encompassing the neck region and CRD was cloned and expressed in *E. coli*.

The recombinant BC expressed was a trimer which further establishes the role of neck region in the trimerisation of the CRDs (*Hoppe and Reid, 1994*). CRDs appear to fold correctly as judged by the similarities in binding between the native and recombinant BC. The binding observed for recombinant molecule is lower than that of the native which comprises of four times more carbohydrate binding sites.

The ligand for conglutinin in the agglutination of the serum reacted erythrocytes has been determined to be iC3b derived from C3b deposited on the

cells (*Lachmann and Muller-Eberhard, 1968; Linscott et al., 1978; Brown et al., 1982*). It has been shown that BC binds to the carbohydrates on the α chain of iC3b (*Hirani et al., 1985*). Certain carbohydrates are able to inhibit the agglutination better than the others (*Leon and Yokohari, 1964; Young and Leon, 1987*). GlcNAc has been shown to be the most potent inhibitor of conglutination (*Young and Leon, 1987*) and also of BC binding to mannan and iC3b (Figure 3-17 and Figure 3-18). The BIAcore data, summarised in Table 3-1, is in accordance with the previously published values. BC shows highest affinity for GlcNAc as determined by BIAcore, in comparison to various other sugars.

Table 3-1: Saccharide specificities of rBC(N/CRD)

Sugar inhibitors	rBC(N/CRD)		nBC	
	BIAanalysis [§] (Figure 3-17)	(Suzuki et al., 1997)	((Holmskov et al., 1995))	(Suzuki et al., 1997)
Galactose	45	46.8	>50	>100
GlcNAc	0.6	0.65	0.75	1.4
Glucose	20	39.5	16	41.5
L-Fucose	15	-	15	-
Maltose	10	25.8	>50	49
Mannose	7	12.3	20	19.5
Xylose	30	-	-	-

[§]The values shown are IC₅₀, the concentrations in mM required for 50% inhibition of binding of rBC(N/CRD) to biotinylated mannan covalently bound to the sensor chip CM5.

Both native and recombinant BC, and SP-D has been shown to mediate haemagglutination and aggregation of IAV particles by binding to the high mannose residue on haemagglutinin (*Hartshorn et al., 1993; Hartshorn et al., 1997; Suzuki et al., 1997*). In the LOS binding assay BC bound to various LOS purified from *K pneumonia*, *P. aeruginosa* and *S. typhimurium*, but was lower than

that observed for SP-D which was used as the positive control. The assay needs to be repeated after checking for any binding of polyclonal antibodies to the LOS used in this assay.

CHAPTER - 4

4 INTERACTIONS WITH BACTERIA

Collectins have been shown to interact with the microorganisms by recognising the surface elaboration composed of sugar moieties. The collectins show binding specificity for particular residues and bind to them in a calcium-dependent manner. The recognition of these residues on the surface of the microorganisms initiates interaction with various innate immune system components.

4.1 MATERIALS

Dulbecco's phosphate buffered saline (Sigma)

Tissue culture grade water (Sigma)

4.1.1 COMPLETE MEDIA

RPMI 1640 With L-Glutamine (Gibco/BRL)

10% (v/v) Foetal Calf Serum (Sigma) in RPMI 1640

100U/ml Penicillin-Streptomycin (Gibco/BRL)

4.1.2 BUFFERS

Sodium Barbital buffer (pH 4.66)

Dulbecco' PBS with calcium and magnesium (PBS/+) Sigma

Dulbecco' PBS without calcium and magnesium (PBS/O) Sigma

4.1.3 BACTERIAL STRAINS

Y1088

Stratagene

Escherichia coli K12 strain, *Staphylococcus aureus* (wood strain) without Protein A and Zymosan (*Saccharomyces cerevisiae*) unlabelled and FITC-labelled were obtained from Molecular Probes Inc, Netherlands.

4.1.4 HUMAN CELL LINE

HL-60 lymphoid cell line (Laboratory stock) (Appendix: D)

4.1.5 ANTIBODIES

Anti-CD11c (KB43)	purified antibody
anti-CD11b (LPM19c)	tissue culture supernatant
anti-VVHA (Vaccinia virus haemagglutinin)	tissue culture cell supernatant

The antibodies were obtained from Dr. Alex Law (MRC Immunochemistry Unit)

4.2 BACTERIAL AGGREGATION STUDIES

In a classic study, Kuan *et al* (Kuan *et al.*, 1992) reported that SP-D bound to and caused aggregation of gram-negative bacteria in a calcium- and carbohydrate-dependent manner. Similar assay has been used to assess the ability of the native and recombinant conglutinin to agglutinate bacteria. The time course of macroscopic bacterial agglutination was monitored using the spectrophotometric sedimentation assay.

4.2.1 CELL CULTURE

An LB/amp plate was streaked with *E. coli* strain Y1088 (from the glycerol stock) and incubated overnight at 37°C. A single colony was used to inoculate 1.5 ml LB and incubated for 2-4 hr and this was sub-cultured into 100ml

of fresh LB and incubated overnight with shaking at 37°C. The cells were harvested and washed twice in Tris-buffered saline. The cell pellet was resuspended in the same buffer and stored at 4°C (the cells remained viable for 5-6 days).

4.2.2 AGGLUTINATION ASSAY

1ml of the Y1088 cell suspension (diluted to an OD of 1.0 ± 0.2 with Tris buffered saline) per test sample, was aliquoted into a 2.5ml cuvettes (Kartell). Native BC ($1 \mu\text{g/ml}$) and rBC ($10 \mu\text{g/ml}$) were added to the cell suspension in the presence on 5mM CaCl_2 or 1mM EDTA. Native SP-D ($1 \mu\text{g/ml}$) was used as a positive control. The agglutination was monitored over 2hr and the absorbance read at 700nm every two minutes, in a Beckman DU630 spectrophotometer. The absorbance values were plotted against time to obtain the agglutination profile for each sample.

Competitive inhibition of agglutination was assessed in presence of 100mM maltose and 10mM GlcNAc. Other sugar residues, fucose, galactose and xylose were also tested. The rate of agglutination of the bacterial cells in buffer alone with or without calcium was also monitored in every experiment.

The nature of aggregates formed during the agglutination assay was determined by microscopy. For each sample, 50 μl of the sediments or the suspension was allowed to adhere to a microscope slide (BDH). A coverslip was then placed over the drop and visualised under phase contrast microscope (Zeiss Axioscope, Zeiss Ltd) and recorded on Kodak TMAX 400Pro film (Kodak Ltd).

4.2.3 BACTERIAL AGGLUTINATION STUDIES

Y1088 cell strain was used to ascertain the ability of lectins to bind to and aggregate bacterial cells in suspension. The assay was monitored for 2hr at room temperature. Macroscopic aggregation and precipitation (Figure 4-1) was observed within 45-90 minutes after addition of the collectins. Native human SP-D (1 μ g/ml) used as a positive control initiated agglutination at about 45min (Figure 4-2). In case of native bovine conglutinin (1 μ g/ml) the bacterial cells started precipitating at approximately 90min (Figure 4-3). Recombinant conglutinin, rBC(N/CRD) (10 μ g/ml) was able to initiate agglutination of the bacteria (Figure 4-4), in approximately 80min. The agglutination profile of recombinant conglutinin, comprising the CRD and neck regions, was similar to that of the native conglutinin.

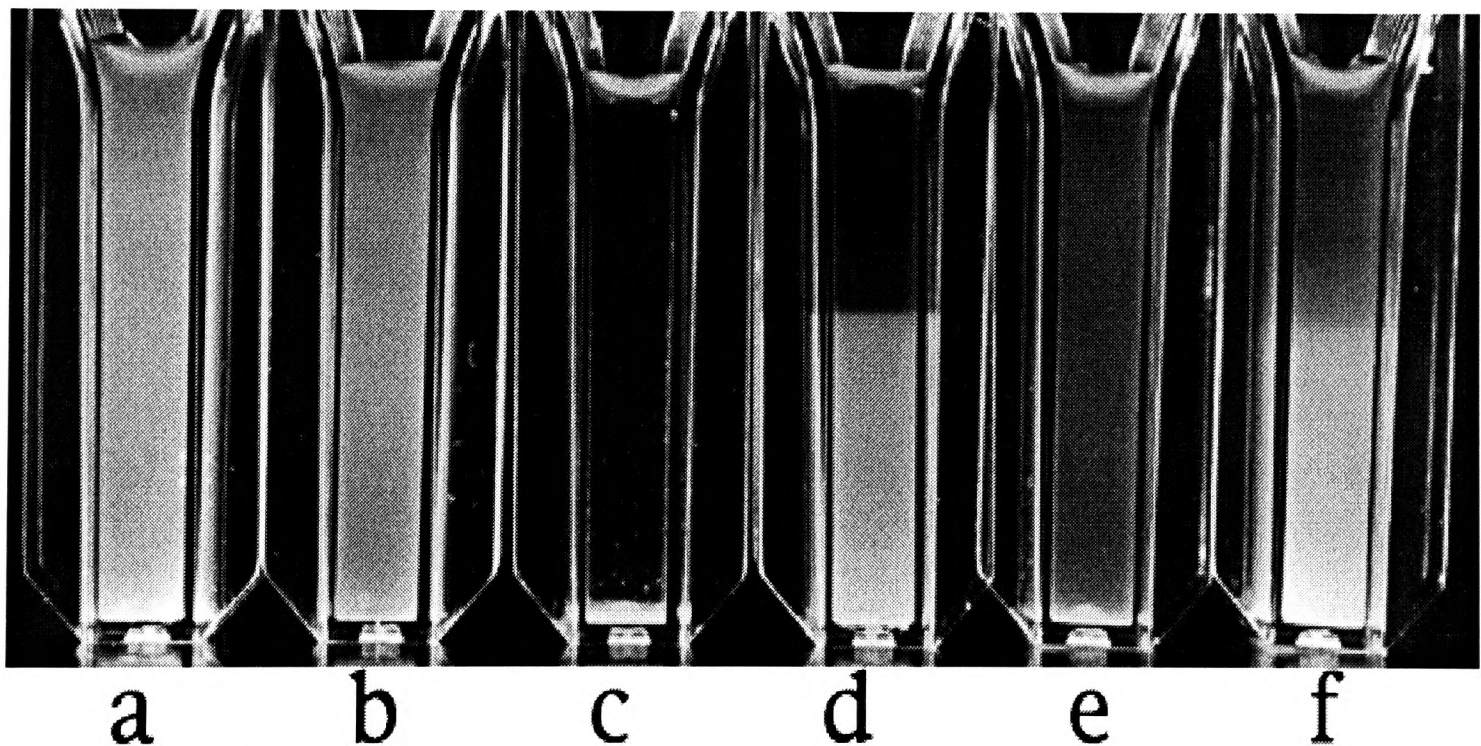

Figure 4-1: Macroscopic Aggregation of *E.coli* strain Y1088.

Cuvette (a) suspension in buffer containing 5mM CaCl₂; (b) suspension in buffer containing 10mM EDTA; (c) bacterial suspension containing 1 μ g nSP-D in calcium buffer; (d) suspension containing 1 μ g nSP-D in EDTA buffer; (e) bacterial suspension containing 1 μ g nBC in calcium buffer; and (f) suspension containing 1 μ g nBC in EDTA buffer.

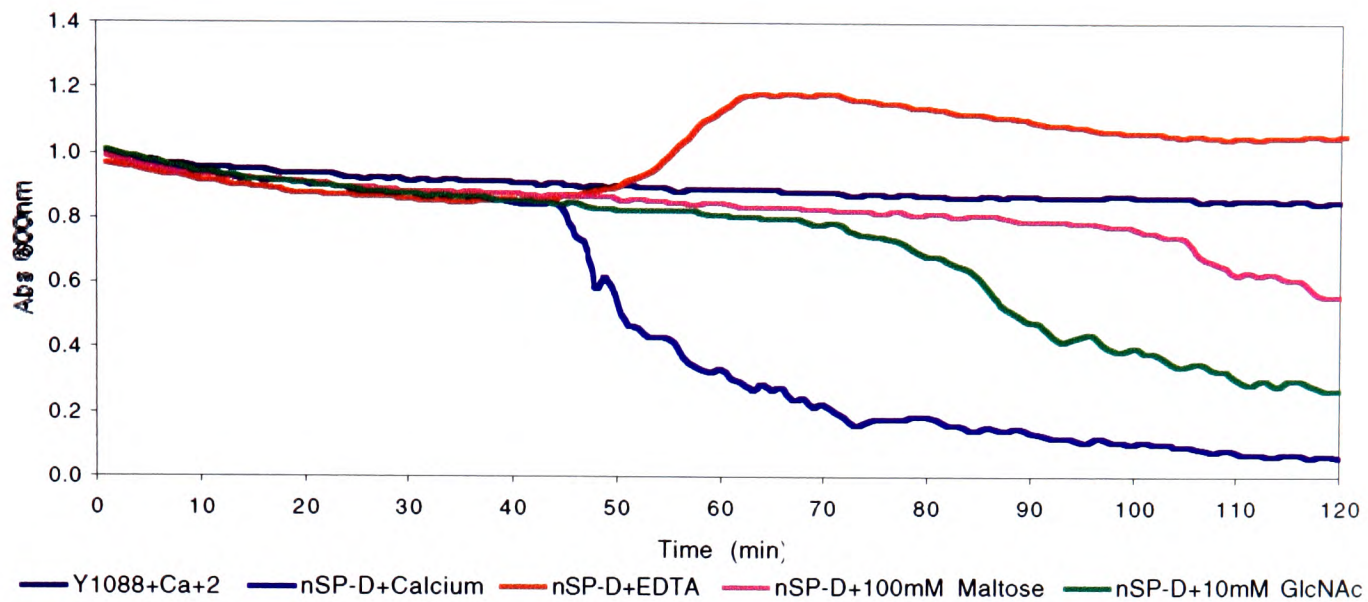

Figure 4-2: Time-dependent nSP-D-mediated Agglutination of *E. coli* Strain Y1088.

Suspension of *E. coli* in Tris buffered saline were incubated with native human SP-D in presence on 5mM calcium. The effects of 10mM EDTA, 10mM GlcNAc and 100mM maltose on the lectin-mediated agglutination were also assayed.

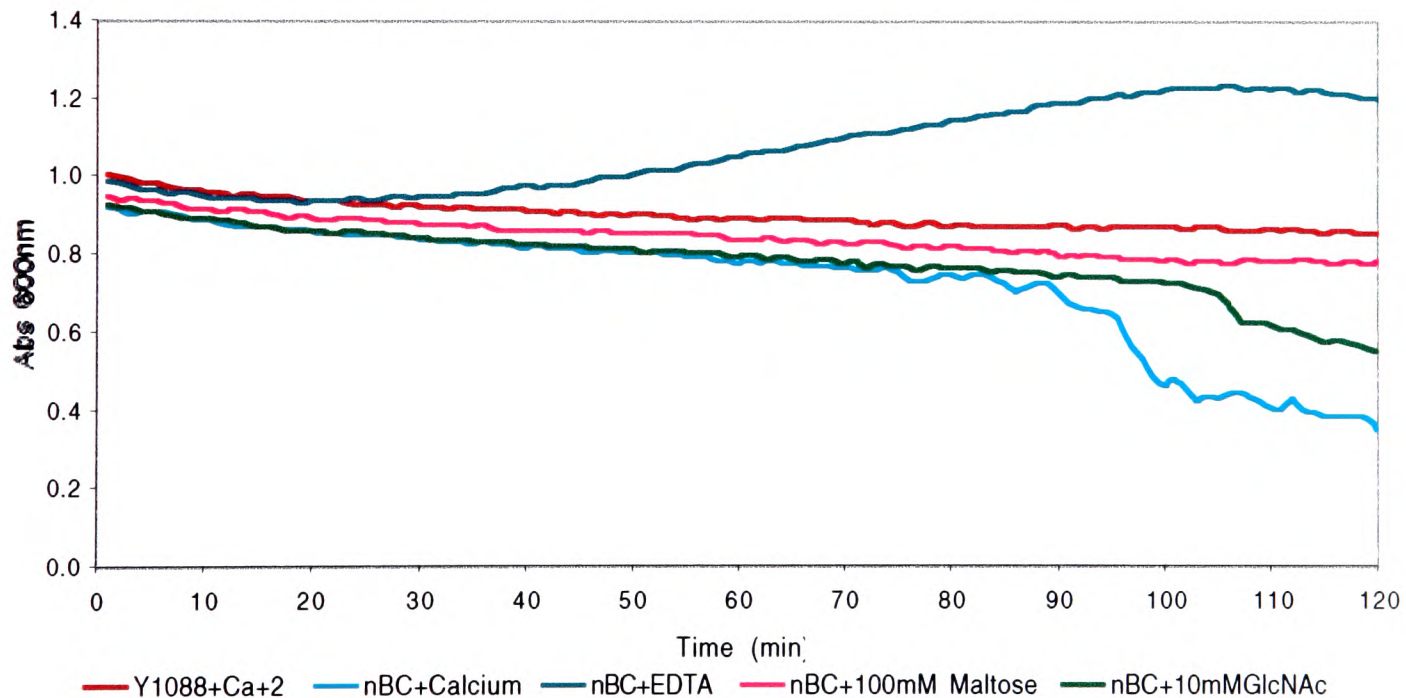

Figure 4-3: Time-dependent nBC-mediated Agglutination of *E. coli* Strain Y1088.

The *E. coli* strain Y1088 was suspended in Tris buffered saline and incubated with native bovine conglutinin in presence on 5mM calcium. The agglutination was monitored over two hours. The effects of 10mM EDTA, 10mM GlcNAc and 100mM maltose on the BC-mediated agglutination were also assayed.

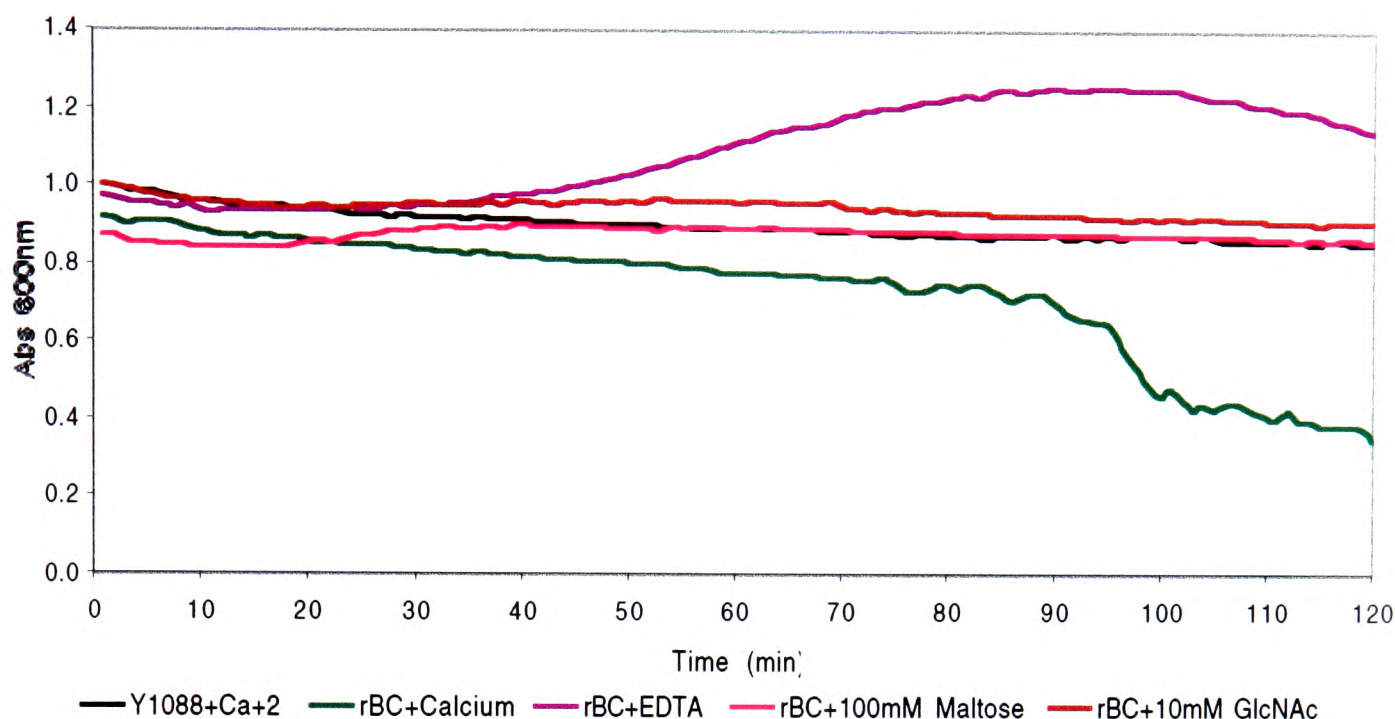

Figure 4-4: Time-dependent rBC-mediated Agglutination of *E. coli* Strain Y1088.

E. coli suspension in tris buffered saline was incubated with recombinant conglutinin rBC(N/CRD) in presence of 5mM calcium. The effects of 10mM EDTA, 10mM GlcNAc and 100mM maltose was assessed. The agglutination was monitored for two hours with the absorbance read every 2min.

Bacterial agglutination mediated by binding of the lectins was inhibited in presence of 100mM maltose, 10mM GlcNAc and 10mM EDTA. Agglutination of bacterial cells by rBC(N/CRD) was completely abrogated in the presence of the inhibitors. The samples containing EDTA showed an increase in the absorbance but no aggregation was observed. The cuvettes containing the sample with EDTA showed increased sedimentation (Figure 4-1).

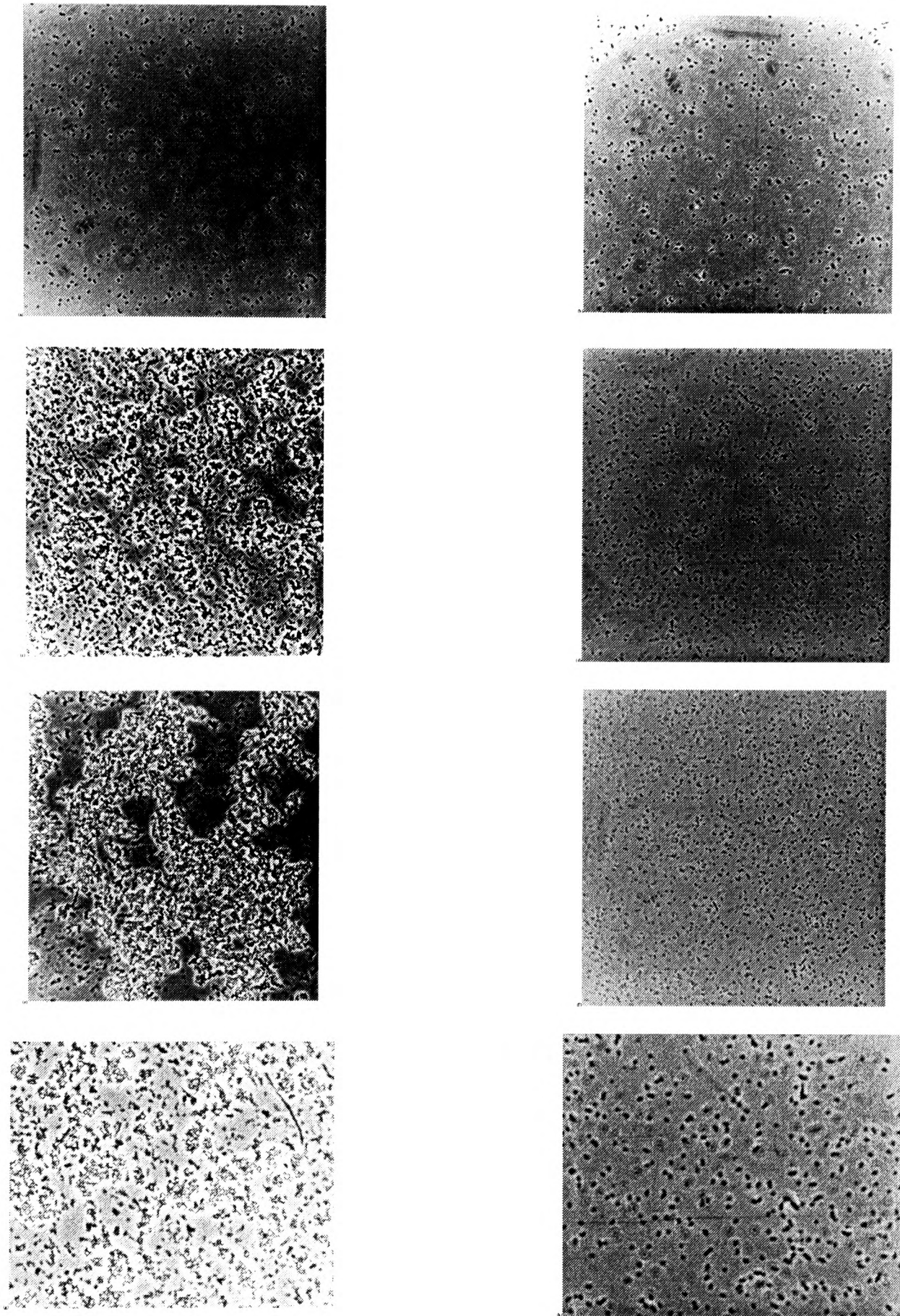

Figure 4-5: Photomicrographs of the Y1088 bacterial cell suspension.

50 μ l of the bacterial cell suspension was allowed to settle and adhere onto a glass slide. The slides were observed under a phase contrast microscope and recorded by a camera. (a) Bacterial cell suspension in a calcium buffer; (b) suspension with 10mM EDTA; (c) with 1 μ g nSP-D in 5mM calcium buffer; (d) with 1 μ g nSP-D in 10mM EDTA buffer; (e) with 1 μ g nBC in calcium buffer; (f) with 1 μ g nBC in EDTA buffer; (g) with 10 μ g rBC(N/CRD) in 5mM calcium buffer and (h) with 10 μ g rBC(N/CRD) in 10mM EDTA.

Bacteria alone or in the presence of calcium did not show any aggregation in the two hours during which the assay was done. The bacterial cells in suspension settled after twelve hours under influence of gravity. No difference in agglutination pattern was observed if the buffer was changed to PBS (data not shown). The bacterial cell clumps formed during the agglutination assay were examined under microscope (Figure 4-5).

The bacterial cells were aggregated by addition of lectins in presence of 5mM calcium. No clumping was observed in the presence of 10mM EDTA. The bacterial cell suspension with out any lectins in presence of calcium or EDTA did not show any aggregation of the cells. The bacterial aggregates formed in the presence of calcium by native SP-D were much larger and dense as opposed to the moderate sized clumps generated by native or recombinant concanavalin. No difference was observed in the aggregates formed by recombinant or the native concanavalin. The increase in absorbance as observed in presence of EDTA showed enhanced sedimentation without aggregation, as indicated by higher density of cells in comparison to that in bacteria suspension without lectins.

4.3 DIRECT BINDING TO BACTERIA

4.3.1 METHOD

Binding of native and recombinant concanavalin to bacteria; *Escherichia coli* K12 strain and *Staphylococcus aureus* (wood strain) without Protein A, and Zymosan (*Saccharomyces cerevisiae*) was assessed by ELISA. The cells ($\sim 10^7$ cells/ml) were suspended in Dulbecco's PBS/O and sonicated in an ultrasonic bath (Mettler Electronics) to obtain a homogenous suspension (as observed under

microscope). The bacteria and zymosan were allowed to dry onto a plate in triplicate at room temperature. Lectins diluted in Dulbecco's PBS/+ were added to the wells at a concentration of 1µg/ml for the native lectins and 10µg/ml for rBC(N/CRD). The wells were then incubated at 37°C for 1hr. after washing with PBS/O anti-BC antibody and anti-SP-D antibody at a dilution of 1:2000 was added to appropriate wells and incubated further for 1hr. Secondary antibody goat anti rabbit IgG conjugated to alkaline phosphatase was added at a dilution of 1:2000 in PBS/+ and incubated for 1hr. The wells were developed with pNPP and the absorbance read at 405nm on a Microtek microtitre plate reader.

4.3.2 RESULTS

Binding of conglutinin and SP-D was examined by solid-phase binding assay. Native hSP-D showed highest binding to *E. coli* strain K12 and bound to *S. aureaus* and zymosan (Figure 4-6). Conglutinin showed little binding to *E. coli* and *S. aureaus* but bound to zymosan with higher affinity. The assay was performed twice and the averaged values of the two assays have been plotted. The antibodies used in this assay were polyclonal anti-BC and anti-SPD. A control sample to test the binding to LOS was not included during the assay and needs to be checked.

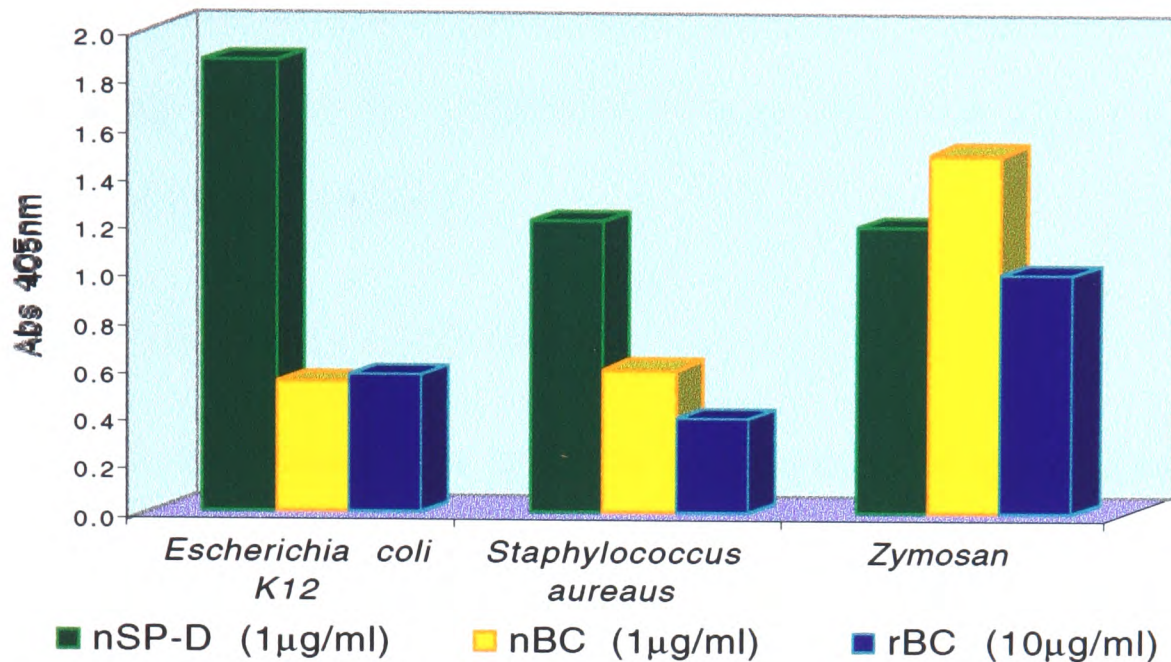

Figure 4-6: Binding of lectins to immobilised bacterial cells.

The bacterial cell suspension was added and were allowed to dry onto the plates. Lectins; conglutinin (native and recombinant) and native SP-D, were added in PBS/+. Native SP-D showed higher binding to *E. coli* and *S. aureus* as compared to native and recombinant conglutinin. SP-D and BC both bound to zymosan.

4.4 HL60 CELL Culture

An aliquot of frozen HL-60 stored in liquid nitrogen (frozen in complete media containing DMSO) was thawed quickly in a 37°C water bath with shaking to prevent ice crystal formation inside the cells. 10 ml of the complete media (at 37°C) was slowly added into cell suspension and incubated for approximately 5 minutes to let the DMSO diffuse out of the cells. The cells were spun down at 400 xg for 5 min and the supernatant was decanted. The pellet was resuspended in 12 ml of the complete media and put the suspension into 50ml tissue culture flask (Nunc®, Life Technologies). The culture flasks were incubated at 37°C in humidified CO₂ incubator (Hereaus Inc.) in 5% CO₂ atmosphere.

two days to maintain the cell line and checked every day for any contamination. Before inducing the cells for differentiation the culture was grown to a cell concentration of 1×10^7 cells/ml.

4.4.1 INDUCTION OF DIFFERENTIATION

The HL-60 cultures were grown to a cell density of approximately 10^7 cells/ml. HL-60 cells were induced with phorbol myristate acetate (PMA) at a concentration of 75ng/ml to differentiate them into macrophage-like cells. To differentiate the cells into the granulocyte-like cell lineage they were induced with all trans-retinoic acid (ATRA) at a final concentration of 100ng/ml. The cells were incubated for 3-4 days at 37°C in CO₂ incubator, allowing the cells to differentiate to the desired lineage. The cells were assessed for the cell-specific markers by FACScan.

4.4.2 FACS ANALYSIS

The cells were harvested by centrifugation at 300g for 5 min at RT and the cell pellet was resuspended in Dulbecco's PBS at approximately 1.5×10^7 cells/ml. 300µl ($\sim 5 \times 10^7$ cells/ml) of this cell suspension was aliquoted into round bottom each well of the tissue culture microtitre plate (Nunc/Gibco). The plates were centrifuged at 300g for 5min at 4°C and the cell pellet resuspended in desired antibody (either tissue culture supernatant or 20µg/ml in PBS/O with 1% BSA). The markers used were CD11c for macrophages and CD11b for granulocytes. Anti-Vaccinia virus haemagglutinin was used as negative control. The cells were incubated for 30-45 minutes at 4°C and then pelleted by centrifugation (300g, 5min). The cells were washed twice in 200µl wash buffer (PBS/O, 0.1% (w/v)

BSA). The cells were resuspended in 50µl of FITC-conjugated secondary antibody, rabbit F(ab')₂ anti-mouse IgG-FITC conjugate (Sigma), diluted according to manufacturer's instructions in wash buffer) was added and incubated further for 45-60 min at 4°C in dark. The cells were spun down at 300g at 10°C for 5min and washed once with PBS. Cells were then transferred into FACS tubes containing 300µl fixative (of 1% (v/v) formaldehyde in PBS/O). The sample were analysed immediately (samples can be stored at 4°C overnight) using a FACScan flow cytometer (Becton Dickinson).

4.4.3 RESULTS

The HL-60 cells were induced with PMA or ATRA to differentiate them into macrophage or granulocyte like cells respectively. A range of concentration of the inducer was used- ATRA: 100-1000ng/ml (Figure 4-7) and PMA: 25-100ng/ml (Figure 4-8). The preferential expression of CD11c is indicative of the differentiation into granulocyte-like cells. CD11b and CD11c are both expressed on the macrophage surface.

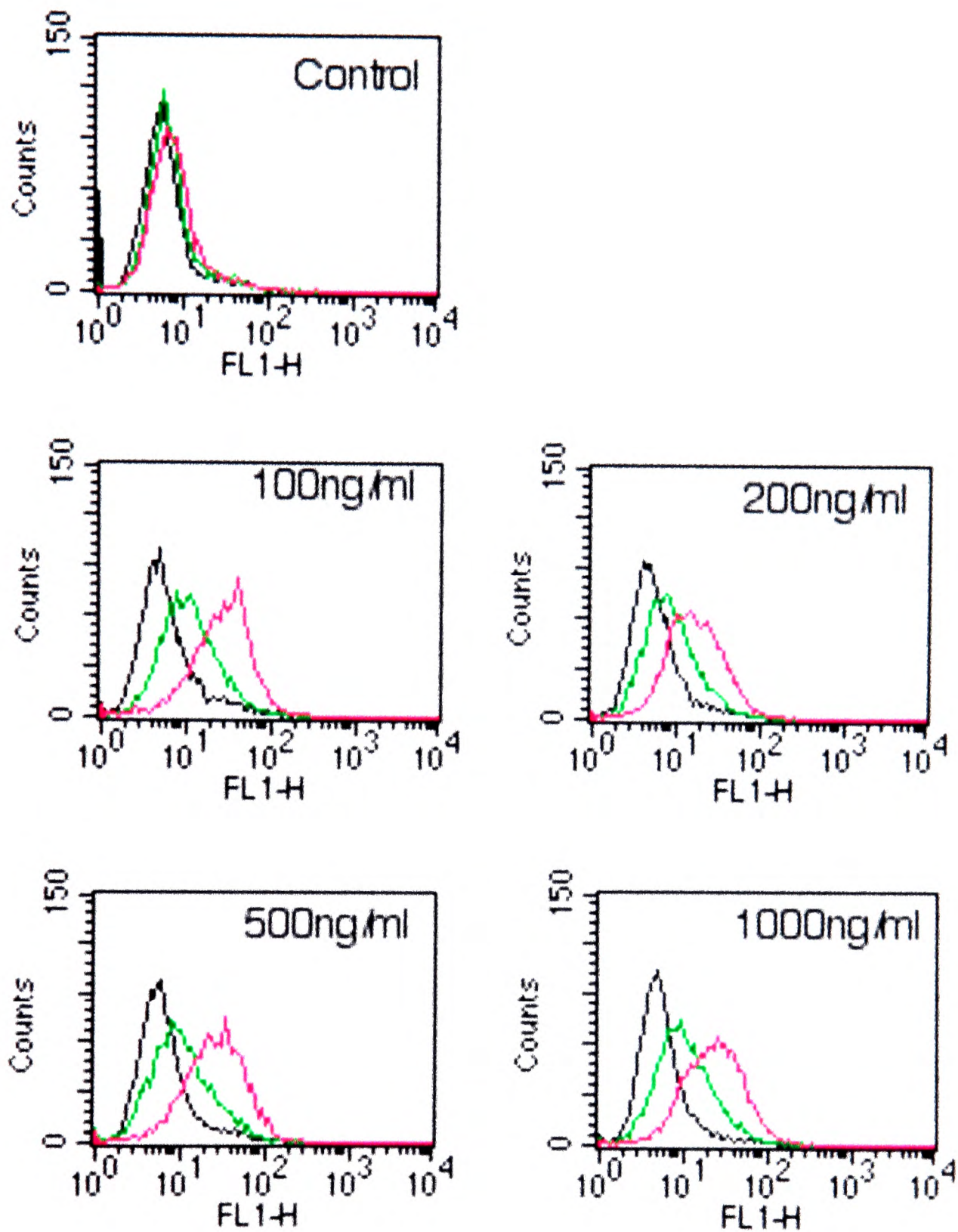

Figure 4-7: Flow Cytometric Analysis of Differentiation of HL-60 cells by ATRA.

The ordinate represents cell number and the abscissa (log scale) represents fluorescence intensity. Cell surface expression of the CD11b and CD11c is indicated by green and pink traces.

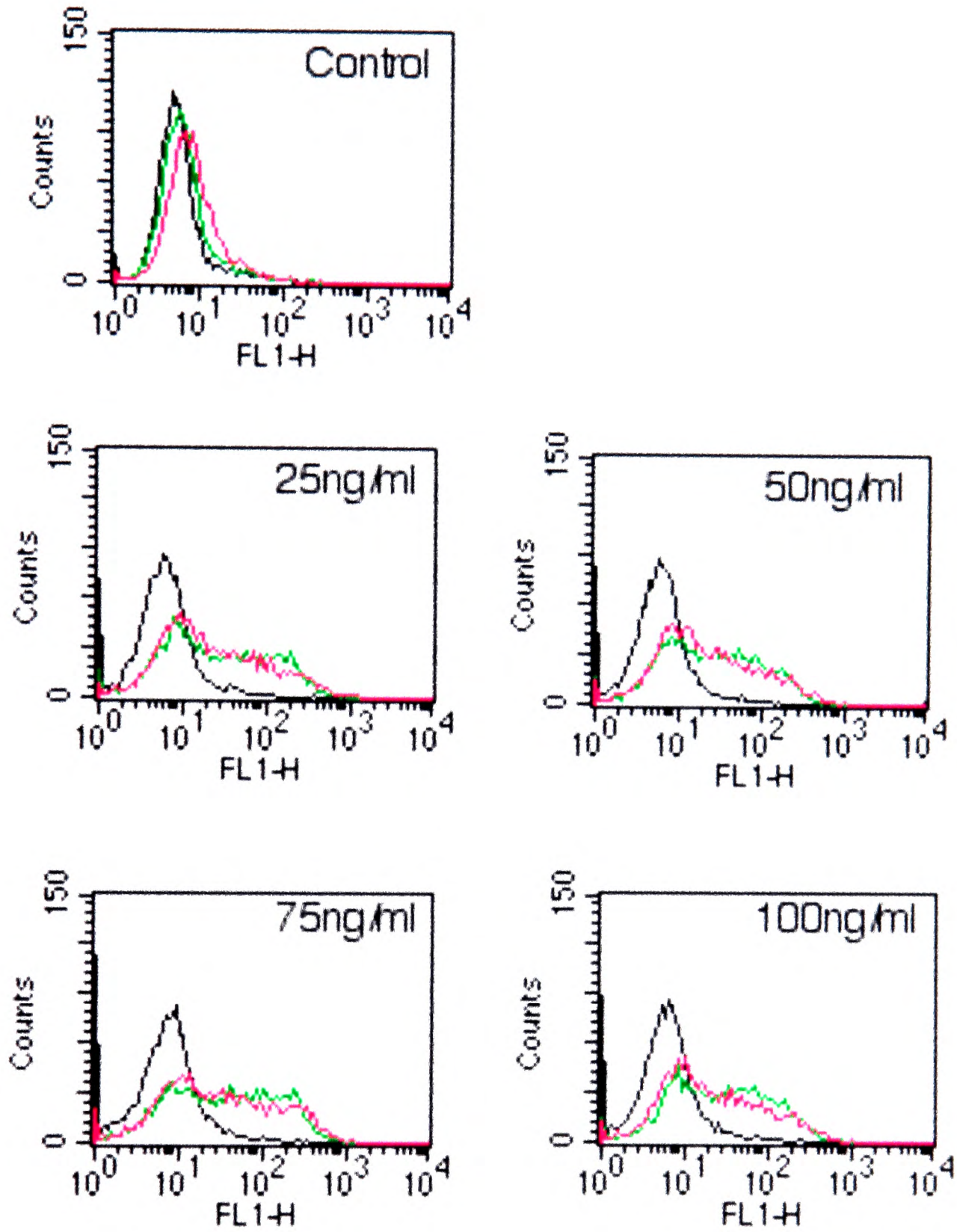

Figure 4-8: Flow Cytometric Analysis of Differentiation of HL-60 cells by PMA.

The ordinate represents cell number and the abscissa (log scale) represents fluorescence intensity. Cell surface expression of the CD11b and CD11c is indicated by pink and green traces.

4.5 PHAGOCYTOSIS

The ability of recombinant and native conglutinin to enhance phagocytosis of bacteria by macrophages and neutrophils was examined by using differentiated HL-60 cell lines as phagocytes. The cells were induced with either PMA (75ng/ml) or ATRA (500ng/ml) and cultured for 4 days. The cell suspension was then aliquoted into each well of 24-well tissue culture plate (Nunc[®]) at a concentration of 10^5 cells/ml. FITC-labelled bacteria, *Escherichia coli* K12 strain, *Staphylococcus aureus* (wood strain) and Zymosan (*Saccharomyces cerevisiae*), were suspended in Dulbecco's PBS/+ and sonicated to obtain a homogenous suspension. Bacteria at a cellular concentration of 10^7 cells/ml were incubated with lectins; nSP-D (1 μ g/ml), nBC (1 μ g/ml) and rBC (10 μ g/ml), for 30min and then added to the differentiated HL-60. The wells were incubated for 4hr in a CO₂ incubator at 37°C. The cells were then harvested by centrifugation at 300g for 5min and washed once with Dulbecco's PBS/O. The cells were resuspended in the buffer and centrifuged onto a microscope slide.

4.5.1 CYTOSPIN

Cell suspension of the differentiated HL-60 cells with the ingested bacteria were washed and resuspended in the Dulbecco's PBS with calcium and magnesium to a concentration of $\sim 5 \times 10^5$ cells/ml. The cytospin cassette comprising microscope slide (BDH), filter (Shandon) and cupule (Shandon) were assembled and clamped to form a unit. 500 μ l of cells were added to the cupule of the cytospin cassette. This concentration gave a uniform monolayer of cells in the resulting round smears. The cells were centrifuged for 5min at 400 rpm at room temperature (with

brakes set to low) in a cytospin centrifuge. The slides with the cell spread were then air dried and mounted with Vectashield™ mounting medium (Vector laboratories, Inc.) for visualisation under microscope.

However, the data could not be collected for this assay due to unavailability of fluorescence microscopes.

4.6 SUMMARY

The property of lectins to bind to microorganisms and aggregate them is an important step in initiating phagocytosis by immune cells. The ability of the lectins to aggregate bacteria was examined by macroscopic agglutination assay. Native SP-D was able to initiate aggregation within 45min as compared to conglutinin, which brought about agglutination of the cells in 90min. Analyses of the aggregates formed revealed the ability of SP-D to form large and dense clumps. It was quite unexpected and interesting to find that recombinant conglutinin was able to aggregate and cause sedimentation of the bacteria. Aggregation essentially would involve crosslinking of the bacteria, mediated by the native molecules, which are tetramers of trimeric heads and can span a distance of approximately 100nm. It remains to be investigated further how a trimeric head is able to induce crosslinking of the bacterial cells.

Direct binding to bacteria was assessed by solid-phase binding assay. Conglutinin did not show much binding to *Escherichia coli* and *Staphylococcus aureus*, which bound higher amount of nSP-D. However, conglutinin showed significantly higher binding to zymosan as compared to bacteria.

4.7 DISCUSSION

Collectins show similarity in their domain organisation and overall three-dimensional structure. They also play similar biological roles in the innate immunity against microorganisms in both serum and lung surfactant. Innate immunity is the first line of defence in the immune system, before the adaptive immune response is developed. The complement system plays a major role in innate immunity and is partly responsible for defence against pathogens before specific antibodies are developed. The microorganisms may activate the complement cascade through three different pathways; the classical pathway, the alternative pathway and the lectin pathway, and bring about lysis of the pathogen by the C5-9 lytic complexes. Other complement fragments generated by the pathway, viz. C5a, C3a, iC3b, C3b and C4b, act as opsonin and activate effector cells and mediate clearance by enhancing phagocytosis. The possible roles of collectins in immune defence and its components have been summarised in Figure 1-7. The collectins have been reported to recognise various bacteria, parasites and viruses through their lectin domains and consequently mediate various defence mechanisms against the invading microorganisms.

BC has been shown to bind to IAV (*Hartshorn et al.*, 1993), HSV (*Fischer et al.*, 1994), rotaviruses (*Reading et al.*, 1998) and show opsonic activity towards *S. typhimurium* and *E. coli* (*Friis-Christiansen et al.*, 1990; *Friis et al.*, 1991). In order to elaborate the mechanism of pathogen clearance mediated by conglutinin, the ability to bind and aggregate bacterial cells was examined by using a macroscopic sedimentation assay. *Kuan et al* had previously used this assay to demonstrate the ability of native human SP-D to aggregate the bacterial cells (*Kuan*

et al., 1992). In this study, SP-D shows the same ability to bind and aggregate *E.coli*, however BC was not as efficient. Recombinant BC(N/CRD) was also able to aggregate cells which is very surprising since clumping or bringing closer the cells would require crosslinking of the cells. This suggests that collectin might use a different mechanism than crosslinking.

BC binds to the complement component iC3b, coated onto the microbial surface during complement activation in response to the pathogens, thereby enhancing the uptake by phagocytic cells. A phagocytic assay was used to elaborate the mechanism of clearance of microbes mediated by BC in the presence and absence of calcium. The bacterial cells were preincubated with the lectins before adding to the macrophages or the neutrophils. The difference in the uptake of the bacteria due to presence or absence of lectin would define the opsonic ability of BC, whether it is consequence of carbohydrate binding alone or would involve other mechanisms as well such as interaction with receptor on phagocyte cell-surface. The assessment of generation of free radicals or reactive oxygen species as a consequence of BC-mediated uptake, would allow better understanding of the mechanism of pathogen clearance in serum.

CHAPTER - 5

5 INTERACTIONS WITH *NEISSERIA*

5.1 INTRODUCTION

Neisseria gonorrhoeae and *Neisseria meningitidis* are the two major pathogens of the genus *Neisseria*, and cause disease exclusively in humans. Several other non-pathogenic species of *Neisseria*, also colonise the oropharynx and the genital tract of the humans. Pathogenic *Neisseriae* are exemplary for their ability to adapt to their sole host: human. Person-to-person spread occurs via mucosal surfaces, with the infection spread by aerosols (meningococci) or through sexual contact.

Neisseria gonorrhoeae, causes the disease through contact with mucosal surfaces such as the urethra, endocervix, pharynx, conjunctiva, and rectum. *N. gonorrhoeae* is an obligate pathogen of humans and cannot survive for more than few hours outside its human host.

A general review on the gonococci is presented in this chapter. An overview of the host-pathogen interactions at the mucosal level, the immune response generated and the immune evasion by the bacteria is discussed. A greater emphasis is laid on the role of lipooligosaccharides in host-pathogen interaction, in specific relevance to role of collectins in pathogens-recognition.

5.2 PATHOGENESIS

Neisseria gonorrhoeae is an extracellular pathogen that has to interact with and overcome various epithelial barriers to establish disease. *N. gonorrhoeae* colonises and invades the epithelium of the genitourinary tract leading to localised

inflammatory process. A large part of the bacterial genome is devoted to coding attributes, proteins and other molecules, necessary for colonisation and survival in their niche, i.e. the genitourinary tract of the asymptomatic carriers of *N. gonorrhoeae*.

Various studies on the gonococcal infection have proposed four stages of infection. The first stage represents attachment and intimate association of the host cell membrane with the organism. This is followed by the uptake of the organisms by the epithelial cells and their subsequent incorporation into vacuoles. In the third phase of infection the gonococci appear to replicate within the vacuoles. In the fourth stage of infection the organisms are released from the cells into the urethral lumen, accompanied by the shedding of infected epithelial cells. The released organisms either infect new epithelial cells or remain in the exudates.

The gonococci have been shown to adhere to the microvilli of non-ciliated cells of the epithelium. They induce focal polymerisation of actin, often accompanied by microvilli extensions. The bacteria enter the apical pole of epithelial cells and transcytose to the basolateral side of the cell. Once in the subepithelial space, they induce the inflammatory process responsible for the disease symptoms.

An important step in microbial pathogenesis is the interaction of the microbe with the host cells and the immune system. Bacteria-host cell interactions involve multiple types of interactions that can contribute to the specificity of a pathogen for a particular host, tissue, and/or cell and for specific mechanisms of virulence. *Neisseria gonorrhoeae* (GC) produces a number of virulence

determinants. Gonococcal infections elicit local and systemic humoral and cellular responses to several of these virulent factors which are surface-exposed antigens particularly pili, porins (Por) or Protein I, opacity proteins (Opas) or Proteins II, reduction-modifiable protein (Rmp) or Protein III and lipooligosaccharides (LOS) (*Schneider et al.*, 1991). Additionally, gonococci expresses marked phenotypic heterogeneity, typically shifting from one antigenic form to another at a frequency of >1 in 10^3 microorganisms (*Tramont*, 1989), making the surface of this pathogen a moving target for most vaccine strategies.

5.3 CELL WALL

The gonococcal cell envelope, like those of other gram-negative bacterial species (*Johnston and Gotschlich*, 1974), consists of an inner cytoplasmic membrane, a middle layer containing peptidoglycan and the periplasmic space, and the outer membrane. Intercollated protein anchor the outer membrane to the peptidoglycan layer; with some of the lipoidal components being glycosylated (*Nikaido and Nakae*, 1979). The latter includes the exterior surface of the organism, which is strategically arrayed at the interface between host and microbe. The outer membrane comprises of a complex mixture of phospholipid, lipooligosaccharide (LOS) and protein, which are organised into an asymmetric lipid bilayer (*Nikaido and Nakae*, 1979).

5.4 SURFACE ANTIGENS

5.4.1 TYPE IV PILI

Pili are long hair-like structures, present on the outer surface, consisting of highly ordered aggregates of identical subunits that form a filament of about $4\mu\text{m}$

in length. They are of paramount importance to the pathogenic process, especially in the adhesion to the epithelial and endothelial cells. Type IV pili are the filamentous structures emanating from the bacterial surface composed of the protein subunit, pilin also termed as Pile. Pilin is incapable of interacting directly with the eukaryotic cells but plays an important role as the fibre scaffold. However, some pilin variants are more efficient than others in enhancing bacterial cell interaction, owing to the ability of these variants to favour agglutination of pili, which then form large bundles (*Marceau et al.*, 1995; *Marceau and Nassif*, 1999). Two mechanisms may explain the enhancement of adhesiveness by bundled pili: (i) aggregative pili increases bacteria-bacteria interactions, (ii) bundles pili could reinforce the interactions of the adhesin with its eukaryotic receptor owing to increased number of adhesin molecules present at the extremity of a bundle.

It has been suggested that 110kDa molecules, PilC, are located in the pilus fibres interspersed between the pilin monomers. PilC carry a cell-binding domain (*Rudel et al.*, 1995) and are therefore viewed as adhesins responsible for pilus-mediated adhesion. In gonococci, two *pilC* alleles have been identified both of which are known to be adhesive.

A major feature of the pathogenic *Neisseria* pilin is that they are glycosylated, containing an O-linked α -1-3 N-acetyl glucosamine (*Parge et al.*, 1995). Glycosylated pilin is not required for pilus biogenesis. The soluble glycosylated pilin monomer is thought to have a role in cell signalling via the cell-binding domain present in the constant region of the pilin, and have an effect independent of their role as building blocks of the pili.

The complement regulatory protein (CD46) has recently been recognised as a pilus receptor for pathogenic *Neisseria* (Kallstrom *et al.*, 1998). This binding is specific to human CD46 and can be blocked by monoclonal anti-CD46 and recombinant CD46 produced in *E.coli*. The consequences of this initial attachment between pili and CD46 remains to be assessed but this interaction is believed to send a signal to the host cells.

5.4.2 OPA^h PROTEINS

Neisseria gonorrhoeae express a family of variable outer membrane opacity-associated (Opa) proteins that recognise multiple human cell receptors. The Opa associated (also called Class 5 protein in *N. meningitidis*) proteins are basic outer membrane proteins with a molecular weight of ≈ 28 kDa (Lambden *et al.*, 1979). They are expressed in most meningococci and gonococci and are structurally similar in both species. Opa expression causes inter-gonococcal adhesion leading to the characteristic opaque colony phenotype (Swanson, 1978; Lambden *et al.*, 1979). Gonococci adhere only to neutrophils and not to erythrocytes, eosinophils, monocytes or lymphocytes (Farrell and Rest, 1990).

The Opa form a family of proteins, each encoded by a distinct *opa* gene. Opa proteins are subject to phase variation owing to the reversible sequence variation in the 5' coding region of their structural genes. Single gonococci may

^h *Neisseria gonorrhoeae* Opa proteins were originally referred to as 'P.II' and those of *Neisseria meningitidis* 'Class 5 proteins' Malorny B, Morelli G, Kusecek B, Kolberg J and Achtman M (1998). Sequence diversity, predicted two-dimensional protein structure, and epitope mapping of neisserial Opa proteins. *J Bacteriol* **180** 5: 1323-1330.. The unifying term Opa replaces these older nomenclatures and is derived from the fact that most Opa

carry up to 12 *opa* genes. Most Opa proteins target the highly conserved N-terminal domain of the CD66 family of adhesion molecules, although a few also interact with heparan sulphate proteoglycans (*Virji et al.*, 1999). CD66 is associated with tyrosine kinases of *Src* family in neutrophils, suggesting an involvement of these kinases in CD66-mediated cell signalling (*Brummer et al.*, 1995; *Skubitz et al.*, 1995). CD66-mediated opsonisation of the Opa⁺ gonococci directs the bacteria to a specific intracellular niche, allowing for prolonged intracellular survival (*Hauck et al.*, 1998). CD66 is also known to activate AP-1 transcription complex via activated JNK, which may promote apoptotic processes of the host cell upon internalisation of the gonococci (*Hauck et al.*, 1998).

5.4.3 PORINS

Porins (Por) comprises approximately 50% of the total gonococcal outer membrane proteins (*James and Swanson*, 1978). Por ranges in mol. wt. between 32,000-39,000 (*Blake and Gotschlich*, 1982) and normally exists as a trimer in the outer membrane forming water-filled pores for the passive diffusion of small hydrophilic molecules. A Por molecule has a hairpin shape with the ends embedded in the membrane and the loop exposed to the extracellular space (*Blake et al.*, 1981).

Pathogenic *Neisseria* produces two porins designated PorA and PorB. Neisserial porins have been shown to translocate spontaneously into the plasma membranes of the eukaryotic cells as functional voltage-gated ion channels,

expressing strain show opaque colony phenotype Hitchcock P J (1989). Unified nomenclature for pathogenic *Neisseria* species. *Clin Microbiol Rev* 2 Suppl : S64-65..

causing a transient change in membrane potential and interference with cell signalling (Ulmer *et al.*, 1992). In gonococci, *porA* has been described as pseudogene, but no PorA protein is produced, whereas there are two alleles identified for PorBⁱ - *porB1a* and *porB1b*. The *porB1a* has been shown to promote bacterial invasiveness in Opa⁻ background (van Putten *et al.*, 1998). These translocated porins have been shown to be capable of nucleating actin, suggesting a role in the host cell actin reorganisation during infection (Giardina *et al.*, 1998).

5.4.4 LIPOOLIGOOSACCHARIDE

Lipooligosaccharides (LOS) are one of the major outer membrane constituents of all gram-negative bacteria. They play key roles in the biology of these organisms (Westphal *et al.*, 1983) and have been found to be important virulence factors in pathogenic species (Griffiss *et al.*, 1987; Griffiss *et al.*, 1988; Verheul *et al.*, 1993). Endotoxin, or lipopolysaccharide (LPS), is a major feature distinguishing Gram-negative from Gram-positive bacteria. LPS is usually the major glycolipid molecule present in Gram-negative bacteria.

Neisserial LOS presents more glycosphingolipids than enteric LPS. Their lipoidal moieties are analogous to those of enteric LPS, but their glucose moieties are triantennary (sometimes biantennary) structures that branch at basal heptose residues (Griffiss *et al.*, 1987; Griffiss *et al.*, 1987). Lipid moiety glucosamines are esterified with laurate, rather than myristate, and both subunits bear normal fatty

ⁱ *PorB1a* and *porB1b* are also referred to as Por1A and Por 1B.

acids (Schneider *et al.*, 1982; Takayama *et al.*, 1986). Laurate residues are differentially hydroxylated.

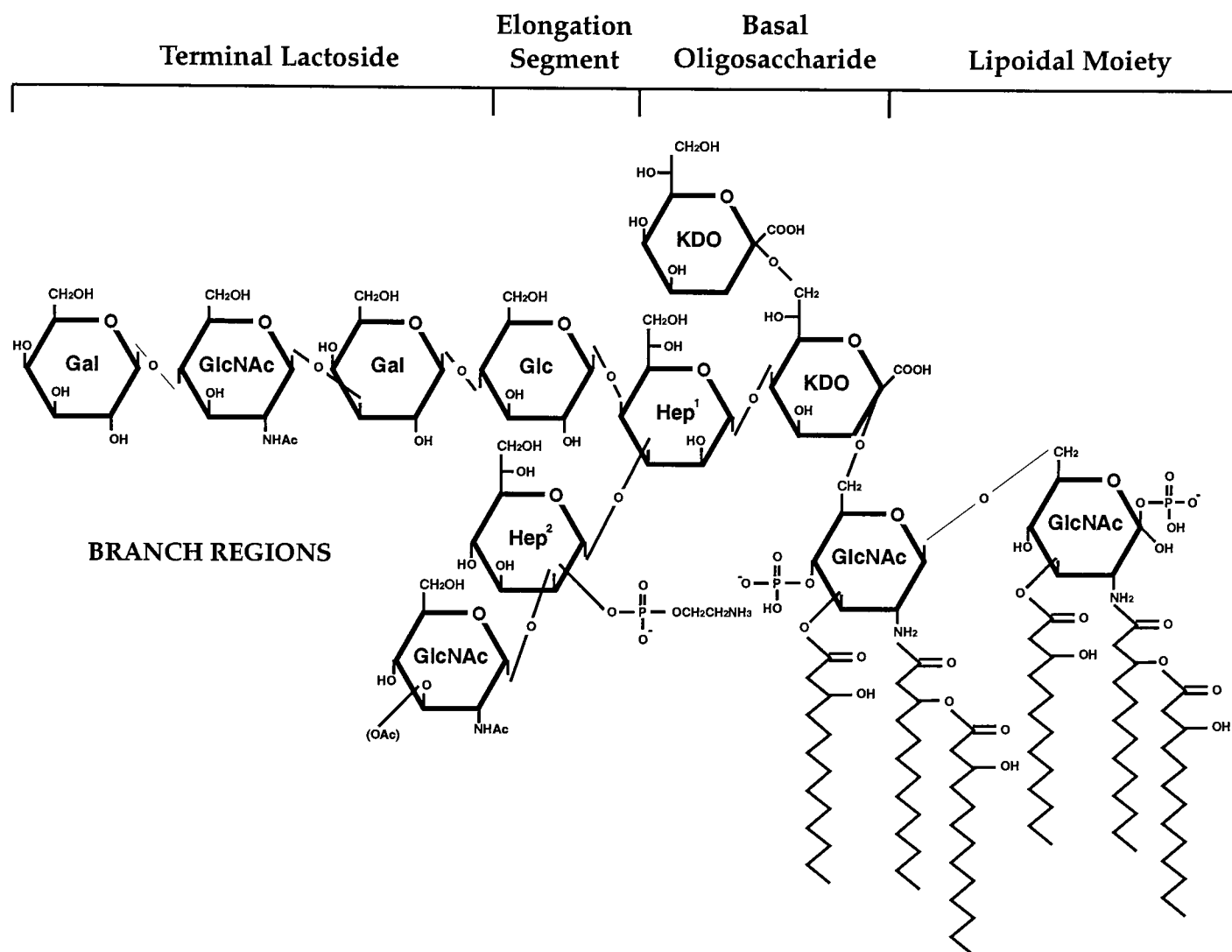

Figure 5-1: Structural model of the Lipooligosaccharide (LOS) structure.

The LOS from *N. gonorrhoeae* strain 1291, showing the membrane-associated lipid A and the inner-core and variable outer-core oligosaccharide moieties. The LOS contains fewer residues as compared to LPS of the enteric bacteria as the O-antigen is absent. GlcN, Glucosamine; KDO, 2-keto-3-deoxyoctulosonic acid; Hep, *L*-glycero-*D*-mannoheptose; Glc, Glucose; Gal, Galactose. Heptoses are designated according to nuclear magnetic resonance (NMR)-labelling assignments, where the KDO-linked heptose is named Hep¹ and so on. The lactoside of the main chain of the LOS terminates in galactose, preceded proximally by GlcNAc and Gal. The elongation segment comprises of glucose (Glc) residues. Hep² of the basal oligosaccharide is substituted with a monosaccharide secondary chain of Glc and with GlcNAc. The terminal tetrasaccharide is the same as the glucose moiety for the glycosphingolipid, lactoneotetraglycosylceramide, of human erythrocytes (Macher and Sweeley, 1978).

Numerous endotoxic activities such as mitogenicity, pyrogenicity, platelet aggregation, cytokine activation, and adjuvant activity have been attributed to

enterobacterial LPS. The lipid A moiety of LOS/LPS is responsible for many of these activities (*Luderitz et al.*, 1973).

The outer membrane of *Neisseria* lacks long polysaccharides and are appropriately termed Lipooligosaccharides (LOS) (*Pepler*, 1984; *Schneider et al.*, 1984; *Campagnari et al.*, 1990). LOS is an outer membrane component that mediates many aspects of disease. It is responsible for damage to human fallopian tubes (*Gregg et al.*, 1981; *Gregg et al.*, 1981) and plays a role in attachment of the bacteria to the epithelial tissue. It is the target for bactericidal antibodies found in normal human serum (*Apicella et al.*, 1986; *Griffiss et al.*, 1991).

LOS consists of a branched oligosaccharide structure which is anchored to the membrane via lipid A. Variation in its structure are observed within as well as between the strains. As a principal surface component, gonococcal LOS interacts directly with host cell membranes and circulating glycoproteins and stimulates an immune response during infection (*Preston et al.*, 1996). Lipopolysaccharide (LOS) is an important virulence determinant of *N. gonorrhoeae*. It is involved in several aspects of gonococcal infection, including immune evasion, attachment, tissue damage, and the stimulation of bactericidal antibodies (*Apicella et al.*, 1986; *Mandrell et al.*, 1990) (*Ward et al.*, 1974). Certain LOS can also activate complement system (*Ingwer et al.*, 1978; *Shafer et al.*, 1984), and some strains with antigenically distinct LOS are able to evade complement-mediated cell lysis (*Rice et al.*, 1987).

5.4.5 OTHER COMPONENTS

Several other bacterial components modulate bacteria-cell interactions. Rmp (Protein III) is a highly conserved, surface- exposed outer membrane protein, with an estimated mol wt of 31,000 (*McDade and Johnston, 1980*). Gonococci produce an adhesin, a 36 kDa outer membrane protein with a binding specificity for a gangliotetraosylceramide. In addition, another inducible gonococcal adhesin has been described that binds luteotropin receptor (*Spence et al., 1997*). IgA1 protease, which is believed to be crucial for mucosal colonisation, has been shown to be important for intracellular survival. This protease cleaves the lysosome integral membrane protein, LAMP1, thereby preventing phagosome-lysosomal fusion (*Lin et al., 1997; Ayala et al., 1998*).

5.5 IMMUNE RESPONSES

The gonococci are capable of proliferating in different physiological environments and have developed a variety of mechanisms for evading the host immune response. Growth in different environments requires special phenotypes, especially with respect to outer membrane components such as pili, Opa, por and lipooligosaccharide (LOS) (*Swanson, 1978; Swanson, 1979; Lambden et al., 1981*). Natural infection with *N. gonorrhoeae* elicit immune response against Pili, Opa protein and Por, but the bactericidal response is directed against LOS (*Lammel et al., 1985*).

5.5.1 INTERACTION WITH COMPLEMENT

The complement cascade (**Figure 1-7**) is activated by microbial surfaces via the alternative pathway (AP), the classical pathway (CP) or the mannose-

binding lectin (MBL) pathway (reviewed in (*DiScipio*, 1997; *Nilsson and Nilsson Ek Dahl*, 1997; *Pangburn*, 1997; *Reid*, 1997; *Reid*, 1997)). Owing to the requirement of the amplification loop, the activation of the complement cascade via the AP is less rapid than activation via CP, which requires the binding of specific antibodies to the microbial surface for its activation. Activation via MBL pathway is similar to the activation via the classical pathway. MBL and its associated serine-protease (MASPS) activate C2 and C4 in the same manner as the complement factor C1q-C1r₂-C1s₂ complex. The central molecule of the complement activation is C3, which consists of an α - and β -chain. Cleavage of the α -chain by C3-convertases of both AP and the CP results in the generation of a 9kDa anaphylatoxin, C3a and the 175kDa C3b molecule. The proteolytic cleavage induces a conformational change in C3b and renders a thioester bond accessible to nucleophilic attack by hydroxyl or amino groups on the bacterial surface, which gives rise to covalently linkage of C3b by the ester or amide bonds. Covalently linked C3b induces the formation of C5 convertases of the AP and the CP which cleave C5 to form C5b and the anaphylatoxin C5a. C5b is the initiation molecule for the membrane attack complex (MAC).

In the alternative pathway of complement activation, C3b is inactivated to iC3b by a protease called factor I, which is required to protect host cells from the complement attack as a result of spontaneous C3 activation in the fluid phase or on cell surfaces. A cofactor to this protease is the 155kDa factor H (fH). The affinity of fH is higher for C3b than to iC3b and higher to surface-bound C3b compared to fluid-phase C3b. fH shows higher affinity to C3b bound to cell surfaces containing sialic acid as compared to surfaces devoid of them, thereby protecting the surfaces

from complement attack (reviewed in (*Pilatte et al.*, 1993; *Pangburn*, 1997)). In contrast to the mammalian cells, the assembly of the terminal membrane attack complex on the gram-negative bacteria is hampered by the presence of two membranes, which cannot be entirely spanned by the MAC to elicit bacteriolysis.

5.5.2 INTERACTION WITH PHAGOCYTES

The extracellular events that take place during the initial phases of phagocytosis include: chemotaxis, opsonisation and cytotoxicity. The principal chemotactic signal relevant to the migration of PMNs to gonococci is C5a, which is generated by the cleavage of complement component C5 by C5 convertase (discussed in 5.5.1 above). This complement-derived neutrophil chemoattractant is markedly increased in serum exposed to serum-sensitive gonococci as opposed to serum-resistant strains (*Densen et al.*, 1987).

Killing is believed to occur in phagolysosome (PL) by two types of mechanisms. The first, which is oxidative, may be the result of toxic products of polymorphonuclear leukocytes (PMNL) oxygen metabolism (H_2O_2 and O_2^- , $\cdot\text{O}_2$ and $\cdot\text{OH}$) or may involve the myeloperoxidase- H_2O_2 -halide triad (*Holmes et al.*, 1967; *Quie et al.*, 1967; *Steigbigel et al.*, 1974; *Johnston et al.*, 1975; *Densen and Mandell*, 1978; *Badwey and Karnovsky*, 1980; *Klebanoff*, 1980). The second, which is non-oxidative, may involve compounds of a cationic nature, permeability-altering protein, or neutral proteases (*Odeberg and Olsson*, 1976; *Odeberg and Olsson*, 1976; *Buck and Rest*, 1981; *Rest et al.*, 1982). The latter enzyme is an important component of PMNL microbicidal systems in conjunction with I^- and Cl^- , utilised as co-factors by PMNs for the purpose of killing (*Kreutzer et al.*,

1979). Gonococcal infection increases the uptake of the anions (*Sukhan and Wiseman, 1991*).

5.5.3 HUMORAL RESPONSE

In response to natural gonococcal infection the antibody response is mainly directed against pili, Rmp, Opa and lipooligosaccharides, with lesser amounts directed against the porin proteins (*Hook et al., 1984; Brooks and Lammel, 1989*). Anti-Por antibodies can be bactericidal (*Hook et al., 1984*), but the antibody response to Por in natural infection is minimal. Bactericidal antibodies against both the serum-sensitive and serum-resistant strains of GC are directed mainly against antigenic determinants on the lipooligosaccharides (*Tramont et al., 1974; Rice and Kasper, 1977; Tramont et al., 1977; Rice et al., 1986*). IgM antibody generated to antigenic determinants on the LOS (*Schoolnik et al., 1979; Rice et al., 1980*) is responsible for a major portion of the bactericidal activity.

5.6 SERUM RESISTANCE

Serum resistance is a crucial factor for the development of disseminated gonococcal infection. Pathogenic *Neisseria* use a variety of mechanisms to survive the bactericidal action of the complement. These factors include capsular polysaccharides and porins.

Gonococcal porins form transmembrane channels enabling the flux of ions and small macromolecules across the membrane (*Judd, 1989*). During complement activation the regulatory protein fH binds to the gonococcal strains via the loop5 of the PorA, resulting increased conversion of C3b to iC3b, thereby reducing bacterial killing (*Ram et al., 1998; Ram et al., 1998*).

Serum-sensitive strains become serum-resistant when grown in presence of CMP-NANA, which sialylates the terminal carbohydrate structure Gal β 1 \rightarrow 4GlcNAc β 1 \rightarrow 3Gal β 1 \rightarrow 4Glc (lacto-*N*-neotetraose) on the LOS (*Nairn et al.*, 1988; *Parsons et al.*, 1988; *Mandrell et al.*, 1990). This structure is also found of paraglobuside (*Mandrell et al.*, 1988). Paraglobuside is the major precursor of the glycolipid ABH antigens of human erythrocytes (*Hakomori*, 1981). *N. gonorrhoeae* does not synthesise sialic acid, but utilises exogenous sources (host) to sialylate its LOS. LOS sialylation contributes to the inducible serum resistance phenotype, which is lost after the passage of fresh urethral isolates on culture media devoid of 5'-cytidinemonophospho-*N*-acetylneuraminic acid (CMP-NANA) (*Nairn et al.*, 1988; *Parsons et al.*, 1988; *Parsons et al.*, 1989). Sialylation of the gonococci delays the complement-mediated opsono-phagocytosis (*Kim et al.*, 1992), which may be due to reduced deposition of C3b or increased conversion to iC3b (*Brown*, 1991).

Complement protein fH shows higher affinity for sialylated LOS, resulting in enhanced cleavage and inactivation of C3b by factor I (*Ram et al.*, 1998). Thus, fH protects gonococci from alternative pathway-mediated killing, by binding to two sites on the gonococcal surface, i.e. PorA and the sialylated LOS.

5.7 LIPOOLIGOSACCHARIDES

5.7.1 STRUCTURE

The structures of pathogenic *Neisseria* LOSs have been most extensively studied. Jennings and his colleagues were the first to report the complete structure of the oligosaccharide moiety of neisserial LOS (*Jennings et al.*, 1983). LOS are

made up of a largely conserved lipid A moiety and a variable polysaccharide built up of non-repeating saccharide units off a much smaller core oligosaccharide (*Griffiss et al.*, 1987) that shows wide antigenic diversity among different strains (*Mandrell et al.*, 1986). These two regions are linked together through one or more acidic sugars identified as 3-deoxy-D-manno-2-octulosonic acid (KDO). The core of the neisserial LOS contains KDO and two heptose moieties (Figure 5-1). Frequently the inner-core sugars are substituted with phosphate and phosphoethanolamine (PEA).

Structural and immunochemical analyses of the LOSs from the gonococcal strain 1291 and its pyocin-resistant derivatives 1291a-e, have revealed that the LOS of 1291 differ in their terminal sugar residues. The main chain sugar residues of this strain are as follows:

1291wt: (KDO - Hep1 - Glc - Gal - GlcNAc - Gal)

1291a: (KDO - Hep1 - Glc - Gal - GlcNAc)

1291b: (KDO - Hep1 - Glc - Gal - Gal)

1291c: (KDO - Hep1 - Glc - Gal)

1291d: (KDO - Hep1 - Glc)

1291e: (KDO - Hep1)

Structures Of The 1291 Wild-type And Pyocin Mutant Oligosaccharides of *Neisseria gonorrhoeae*

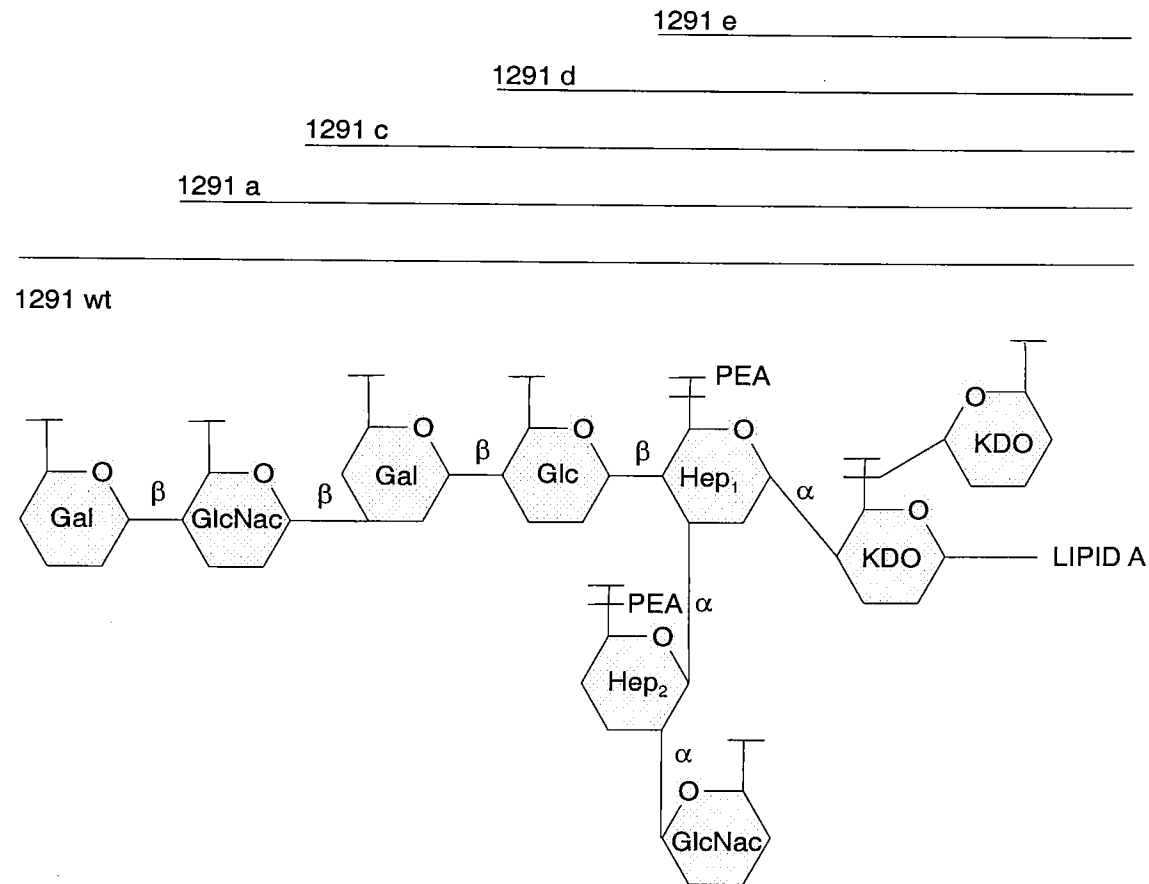

(a) LOS structure of 1291 wild-type, 1291a, 1291c, 1291d and 1291e, sequentially deficient in a terminal hexose.

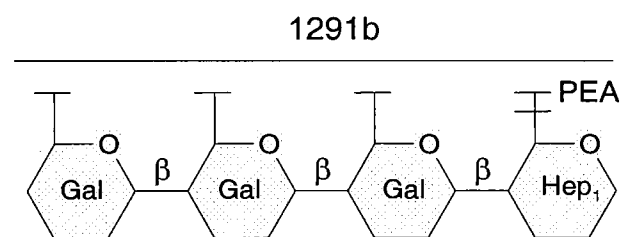

(b) LOS structure of 1291b with a terminal galactose instead of a N-Acetyl Glucosamine.

Figure 5-2: Structure of the lipooligosaccharides of the pyocin-resistant 1291 series.

The core saccharide structure of the 1291 LOS is same as the 1291 wild-type and others.

Four of the five variants make oligosaccharides that differ from the wild type by successive deletion (*John et al.*, 1991). The fifth variant, 1291b, makes the

structure that differs from the parent strain after the formation of the lactose disaccharide branch, Gal β 1 \rightarrow 4Glc. The ring structures of the 1291 series are shown in Figure 5-2.

5.7.2 PYOCIN RESISTANCE

LOS mutants have been identified on the basis of resistance to killing by pyocin (*Guymon et al.*, 1982; *Dudas and Apicella*, 1988). Pyocin is a bacteriocin produced by *Pseudomonas aeruginosa* that binds to receptors in gonococcal LOS and initiates cell lysis (*Morse et al.*, 1980). Cells that resist the killing action of pyocin have been shown to possess altered LOS components (*Guymon et al.*, 1982; *Dudas and Apicella*, 1988). Dudas and Apicella isolated an isogenic set of pyocin mutant series of strain 1291 that differ in monoclonal antibody (mAb) reactivities and migration on sodium dodecyl sulphate-polyacrylamide gel electrophoresis (SDS-PAGE) (*Dudas and Apicella*, 1988). Structural analysis has shown that these strains differ in specific sugar deletions in the carbohydrate moiety of LOS (*John et al.*, 1991).

Pyocin resistance in a strain of *Neisseria gonorrhoeae* has been found to be associated with structural differences in the oligosaccharide moieties of the gonococcal outer membrane LOS. The region responsible for the alteration of the LOS expression in 1291 has been mapped to *lsi-2*, which contains two ORFs, which overlap with each other. Each of these ORFs contain a string of twelve guanines (*Danaher et al.*, 1995) and the region downstream to *lsi-2* contains additional genes for the LOS biosynthesis (*Gotschlich*, 1994). The ability of the gonococcus to change the number of guanines in *lsi-2* would provide a mechanism

that would allow for a rapid change in the LOS phenotype expressed by a cell (Danaher *et al.*, 1995).

5.7.3 BIOSYNTHESIS

LOS is a complex molecule, assembled through the action of multiple gene products and comprising of numerous components. The heterogeneity and phase variations are further complexities. Many of the genes involved in the LOS biosynthesis have been identified, even though their regulation and control-mechanisms remain largely unknown. The lipid A proximal oligosaccharide region of LOS, the KDO-heptose region, is highly conserved between species. The genes responsible for the biosynthesis of the L-glycero-D-mannohptose have been identified as *rfaC*, *-D* and *-F* (Zhou *et al.*, 1994; Drazek *et al.*, 1995; Schwan *et al.*, 1995). The variable oligosaccharide region consisting primarily of glucose, galactose and GlcNAc are assembled through the action of glycosyltransferases, which sequentially adds sugar residues to a specific acceptor structure of the growing oligosaccharide chain. The *lgt* gene cluster of *N. gonorrhoeae* consists of about five gene that encode the transferases which assemble the lacto-N-neotetraose structure (Gotschlich, 1994).

Many genes of the central metabolism affect LOS biosynthesis through their effect on the availability of LOS components. Sugar and lipid metabolism that produces LOS components is fully integrated with central metabolism. Housekeeping gene *galE* encodes UDP-galactose-4-epimerase, which determines the balance between cellular UDP-glucose and UDP-galactose levels. This is important for the bacterium's ability to utilise galactose as carbon source. *galE*

mutants accumulate galactose and are unable to produce galactose-containing LOS (*Preston et al.*, 1996). *Neisseria* phosphoglucomutase mutants are unable convert glucose-6-phosphate to glucose-1-phosphate, and as a result are unable to synthesise UDP-glucose (*Sandlin and Stein*, 1994; *Zhou et al.*, 1994). Thus, the LOS from the *Neisseria* PGM mutants lack glucose and is truncated (*Zhou et al.*, 1994). However, the presence of some higher molecular weight LOS suggests the presence of some compensatory mechanism in these mutants (*Sandlin and Stein*, 1994).

Phase variation of LOS is thought to occur primarily through the differential expression of LOS biosynthetic genes, which may occur through variation of the repetitive DNA elements. Addition or deletion of these DNA elements is thought to be the plausible mechanism for the phase variation of LOS and also of the gonococcal opacity proteins. Thus, regulation of LOS biosynthesis may operate at many levels, including random-phase variation of individual genes producing a large LOS repertoire and at a more global level in response to metabolic status or specific environmental signals.

5.7.4 ROLE IN PATHOGENESIS

Lipooligosaccharides are among the outermost components of the bacterial membrane, which permits interaction with mucosa, host-cell membrane and circulating glycoproteins that initiate immune effector mechanisms. They are highly bioactive and serve as polyclonal stimulators of the immune system, non-specific activators of the complement system and initiators of the protease cascades that culminate in clotting and the release of kinins (*Luderitz and Westphal*, 1966).

The majority of the inflammatory effects associated with inflammatory response at the site of infection are related to the release of LOS.

Specific LOS structures may be important for adherence to and invasion of host cells. The LOS phenotype is a critical factor in gonococcal invasiveness (*Schwan et al.*, 1995). It has been suggested that LOS containing lacto-neotetraose may be an important factor in a ligand-receptor-based interaction between gonococci and host cells.

The LOS of *Neisseria* can act as a ligand for human receptors, promoting invasion of host cells. The gonococci expressing terminal Gal β 1 \rightarrow 4GlcNAc asialo-LOS has been shown to bind to asialoglycoprotein receptor which are present on the surface of human macrophages, sperm and hepatocytes (*Porat et al.*, 1995; *Porat et al.*, 1995). The expression of the ASGP-R (46-kDa) in hepatoma cell line HepG2 was enhanced following incubation with gonococci. Gonococcal LOS has also been shown to bind to a 70-kDa receptor on HepG2 cell line, in a mechanism similar to the receptor-ligand interaction between LOS-Opa proteins (*Porat et al.*, 1995; *Porat et al.*, 1995).

Gonococcal LOS shares structures and epitopes with human glycosphingolipids that are precursors to blood group antigens (*Mandrell and Apicella*, 1993). These oligosaccharides are sialylated *in vivo* by host 5'-cytidine monophosphate-*N*-acetylneuraminic acid (CMP-NANA) in a manner similar to that of host glycosphingolipids (GSL) (*Mandrell and Apicella*, 1993). Since the terminal sequences of neisserial LOS are common to human glycosphingolipids, they may not be immunogenic (*Bertram et al.*, 1976; *Schneider et al.*, 1985).

5.8 INTERACTION WITH LECTINS

Lectins are non-enzyme, non-immunoglobulin proteins that have at least one carbohydrate-binding domain, involved in many different steps in the host-pathogen interaction. The family of lectins studied most extensively is the C-type lectins, which can be soluble secretory proteins or integral membrane proteins, selectins and collectins. Each carbohydrate-binding domain has one or two binding sites (*Weis et al.*, 1992) with specificities including a wide range of terminal monosaccharide residues (Man, Glc, Fuc, Gal, GalNAc and GlcNAc). Higher-affinity binding appears to be conferred by multivalent interactions between a multimeric lectin and the precisely spaced antennae of complex saccharides (*Rice and Lee*, 1990; *Rice et al.*, 1990). Soluble lectins with two identical (e.g., galectin: L14, collectins) or two different lectin domains may function as bridges between bacterial and host-cell carbohydrates. Furthermore, a lectin with a carbohydrate-binding domain and a non-lectin domain could act similarly (e.g. MBL). Conversely, a soluble lectin with a single carbohydrate-binding site could block the binding of the bacterial carbohydrates with other molecules.

A number of mucosal pathogens have been identified that express polysaccharides or glycolipids that are potential ligands for certain types of lectins. The C-type lectins identified in mucosal epithelia known to interact with mucosal pathogens include Lung Surfactant Protein-A and D in alveolar type-II cells. However, the mannan-binding animal lectins and their interaction with microbes are the best characterised discussed in section 1.6.2. The serum MBL activates complement in an antibody independent manner when it encounters cognate carbohydrates on a microbial surface (*Sastry and Ezekowitz*, 1993). A recent study

on MBL-mediated killing of the pyocin-mutant strain 1291 has indicated the ability of MBL to initiate antibody-independent killing of the serum-resistant strain. MBL showed differential binding to the mutant expressing terminal GlcNAc LOS and activating the lectin and alternative pathways. However, the complement-mediated killing was dependent on pre-opsonisation of the strain with MBL-MASP (*Gulati et al.*, 1998).

In this study, 1291 strain of *N. gonorrhoeae* was selected as a model to elucidate the collectin-pathogen interactions. The pyocin-resistant 1291 series display a relatively simple LOS profile with specific terminal sugar residues on their surface. Six mutants; 1291 wild-type, 1291a, 1291b, 1291c, 1291d and 1291e are sequentially deficient in terminal hexoses, as discussed in section-5.7.1 above. Collectins show preferential binding to specific sugar residues, which is the molecular basis of pathogen recognition. The clearance of pathogens is initiated by the identification of sugar residues on the bacterial surface, subsequently eliciting relevant immune response. This model allows for a greater understanding of these interactions that can be subsequently translated to *in vivo* situations. The studies presented in this chapter are preliminary, which need to be extended to physiological conditions that could not be pursued due to time limitation and unavailability of appropriate equipments.

5.9 MATERIALS AND METHODS

The culturing and preparation of LOS was done at Maxwell Finland Laboratory of Infectious Diseases, Boston Medical Centre, under supervision of Dr S. Gulati. The binding studies were conducted at MRC Immunochemistry Unit.

Materials^j sent over from Boston, USA included: 1291 series as dry cells and in transport media, and LOS from the respective strains. Cell culture was only carried at the MRC Unit in order to prepare glycerol stocks.

5.9.1 STRAINS

Serum-resistant *N. gonorrhoeae* 1291 wild type (1291wt) and mutants; 1291a, 1291b, 1291c, 1291d and 1291e have been used in this study. The strains were transported in Wilkins-Chalgren anaerobic transport media. The glycerol stocks of all strains were stored at -70°C in Tryptic Soy Broth containing 20% glycerol. Media used have been described in appendix A.

5.9.2 SHIPPING THE STRAINS

The 1291 series gonococci were shipped in Wilken-Chalgren Anaerobe Broth. Cells were streaked onto chocolate-agar plate and incubated overnight at 37°C in CO₂ incubator. The growth on the plate was removed with a sterile swab and stabbed into the transport media. With the swab in place and the cap replaced tightly, the vial were incubated overnight at 37°C in CO₂ incubator. The cultures were shipped the next day.

5.9.3 CULTURING THE BACTERIA

The swabs from the culture tubes were used to plate the bacteria onto a blood agar plate containing isovitalex. The plates were placed in a CO₂ jar (Oxoid)

^j Safety clearance was obtained from the University of Oxford before importing the gonococci and starting the experiments. The strains had not been genetically modified, so an import permit was not required (Appendix: E). Appropriate class-II procedures were

with a CO₂ generating sachet (Oxoid). The jar was the clamped to ensure a tight seal and placed in a 37°C incubator and left overnight (16-18hr). The plates were checked the next day for growth and any contaminants. The growth was then picked from the plate with a sterile cotton swab (BDH) and stirred into 1ml of tryptic soya broth in a 2ml cryovial (Nunc). The cells were then stored at -70°C.

5.9.4 PREPARATION OF THE LOS

The 1291 series was grown and cultured by Dr. S. Gulati, at the Maxwell Finland Laboratory of Infectious Diseases, Boston Medical Centre, Boston (USA). The cells were scraped from the plate surface by a sterile cotton swab and stabbed into Wilken's chalgren media in a glass tube. The tubes were then sealed and shipped (overnight delivery). The strains were cultured the next day.

Ice scrapings from the glycerol stocks (as described in section 5.9.3 above) were used to start the fresh gonococcal cultures and streaked onto fresh blood agar plates. The plates were incubated at 37°C in a CO₂ incubator. The culture was then passed onto 10 plates per strain and incubated overnight. It was then pass onto 100 plates to obtain sufficient amount of organism to isolate LOS. The cells were scraped from the plate's surface into a beaker (on ice) containing 500ml of normal saline. The suspension was then centrifuged at 10,000 rpm for 15 min. The pellet was then resuspended in normal saline and repeated the centrifugation. A plate was streaked out of each pellet to check for contamination. The pellet was resuspended in double distilled water and lyophilised. The culture

used while handling the organism. The waste generated was treated as clinical waste and disposed of accordingly.

plates were checked next day. No contamination was observed in the streaks^k and the dried bacterial mass was weighed.

The LOS was extracted and purified by a modified hot phenol-water method. For every 2g of dry organism, 35ml of double distilled water was added and heated the suspension at 65°C with constant stirring. After 5 min, 35ml of 90% (v/v) phenol was added and heated further for 15 min. The mixture was then cooled down to 10°C and then centrifuged in glass tubes at 10,000 rpm for 15 min. The aqueous layer was aspirated and 35ml of double distilled water was added to the residual pellet from the tubes. This extraction procedure was repeated twice to get as much LOS out of the organisms. All the aqueous layers were pooled and centrifuged again to remove insoluble material.

The LOS containing layer was then dialysed against continuously running double distilled water for a month at 4°C to leach out any residual phenol. The LOS was precipitated with 80% (v/v) ethanol containing 50mM sodium acetate overnight at -20°C. The suspension was then centrifuged at 5000 rpm for 15 min and the pellet dried at room temperature overnight.

The pellet was resuspended in 10ml double distilled water and centrifuged in an ultracentrifuge at 30,000 rpm for 3 hours. The supernatant was decanted and its absorbance read at 280 and 260nm. The ultraspins were repeated till the absorbance reached below 0.1-0.2. The final pellet was resuspended in a small volume of double distilled water and lyophilised.

^k If the streaks are contaminated then dried bacteria has to be discarded and need to

5.10 BINDING TO LIPOOLIGOSACCHARIDES

The LOS extracted from the 1291 wild type and pyocin-mutant were suspended in sodium barbital buffer (pH 4.66). The LPS solution was warmed to 37°C for 5min and sonicated in ultrasonic bath (Mettler Electronics) for 5 min to get a homogenous solution. The LPS was coated onto 96-well Immulon 1B (Dynex Technologies Inc, USA) at a concentration of 1mM/well and left overnight at 4°C. The lectins; native and recombinant conglutinin were added at a concentration of 1µg/ml and 10µg/ml respectively. The plates were incubated at 37°C for 90 min. The wells were then incubated with 100µl of 1:2000 dilution of rabbit anti-BC or anti-SP-D antibodies for 1hr at 37°C. Goat anti-rabbit IgG conjugated to alkaline phosphatase was added to the wells at a dilution of 1:2000 and incubated further for 1 hr. The plates were developed by adding 200µl of p-Nitrophenyl phosphate (Sigma Fast™ tablet) in Tris buffer and incubated at RT for 30min. The absorbance was recorded at 405nm on Microtek microtitre plate reader.

The lectins and the antibodies were diluted in Dulbecco's phosphate buffered saline with calcium (Sigma Chemicals). The plates were washed between steps of adding lectin and antibodies in Dulbecco's Phosphate buffered saline without calcium containing 0.1% (v/v) Tween-20.

5.10.1 RESULTS

The binding affinity of lectins, bovine conglutinin and human SP-D, for LOS isolated from the 1291 pyocin mutants of *Neisseria gonorrhoeae* was assessed

start afresh. Gram staining was also done to check the homogeneity of the streaks.

5.10.1 RESULTS

The binding affinity of lectins, bovine conglutinin and human SP-D, for LOS isolated from the 1291 pyocin mutants of *Neisseria gonorrhoeae* was assessed by ELISA (Figure 5-3). Native conglutinin showed highest binding affinity for 1291a, which was significantly higher than that observed for other mutant strains. Native SP-D bound to 1291 wild type, 1291a and 1291b equally well.

The antibodies used in this assay are polyclonal anti-BC and anti-SPD. A control to test the binding to LOS was not included during the assay and needs to be checked.

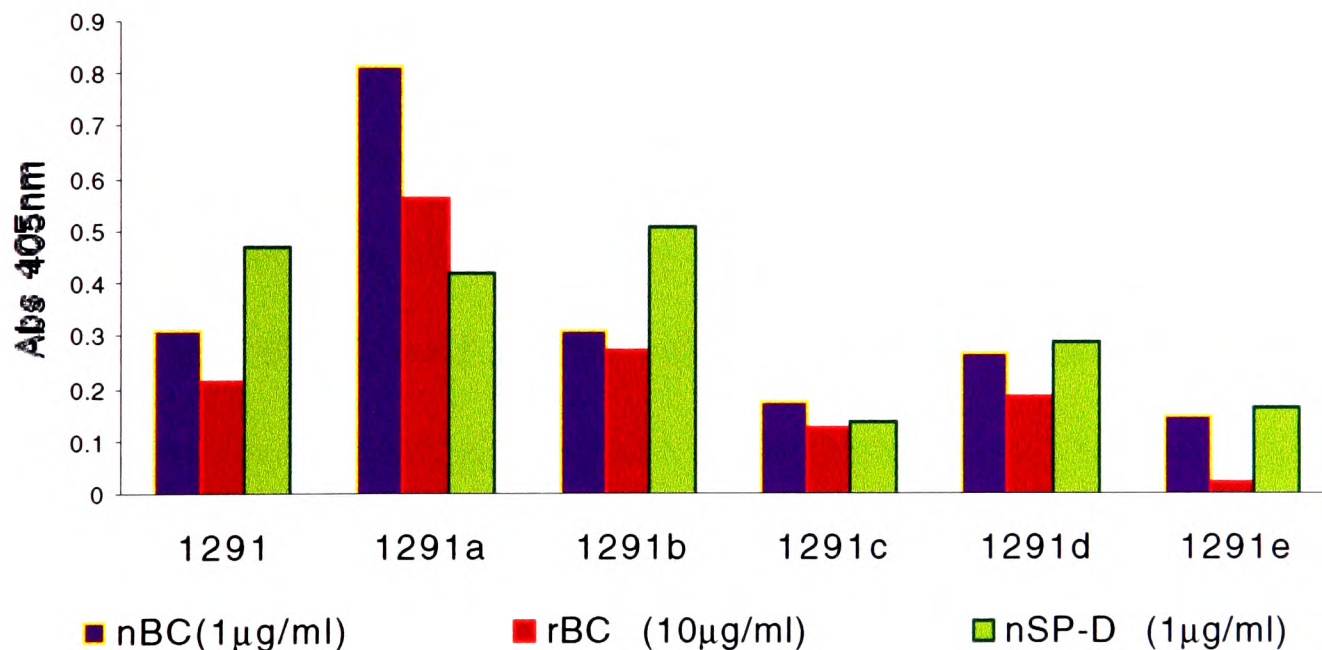

Figure 5-3: Binding of conglutinin and SP-D to gonococcal LOS.

LOS isolated from the pyocin mutants 1291 series were coated on the well at a concentration of 1mM/well. The binding was assessed by a solid-phase binding assay. The plates were developed with pNPP at RT and absorbance read at 405nm. Conglutinin bound to 1291a mutant which was significantly higher than other mutants.

well Immulon 1B (Dynex Technologies Inc, USA) in carbonate/bicarbonate buffer (pH 9.6) and left at room temperature for 1h. After washing the plates with Dubecco's PBS/O, 100µl samples of lectins, rBC (10µg/ml) and nBC (1µg/ml), diluted in PBS/+ were added to the wells. The wells were incubated at 37°C for 1hr. Anti-BC antibody (rabbit) at a dilution of 1:2000 was added to the wells after washing and incubated further for 1hr at 37°C. Secondary antibody, goat anti-rabbit IgG was then added to the wells at a dilution of 1:2000 and incubated for another hour. The plates were developed by adding 200µl of p-Nitrophenyl phosphate (Sigma Fast™ tablet) in Tris buffer and incubated at RT for 30min. The absorbance was recorded at 405nm on Microtek microtitre plate reader.

5.11.2 RESULTS

Binding of native (1µg/ml) and recombinant (10µg/ml) conglutinin to whole 1291 mutant cells was assessed by solid-phase binding assay ([Figure 5-4](#)). Both nBC and rBC showed highest binding to pyocin mutant 1291a, which presents a terminal N-acetyl glucosamine. All the strains have a terminal GlcNAc residue in the side chain, which would be a ligand for BC, however BC shows binding to 1291a and some binding to 1291e. The mutant stain 1291e has all the residues cleaved off and only the chain is present. The absence of the main chain would allow the exposure of the GlcNAc resulting in the little binding observed.

The antibodies used in this assay are polyclonal anti-BC and anti-SPD. A control to test the binding to LOS was not included during the assay and needs to be checked.

residues cleaved off and only the chain is present. The absence of the main chain would allow the exposure of the GlcNAc resulting in the little binding observed.

The antibodies used in this assay are polyclonal anti-BC and anti-SPD. A control to test the binding to LOS was not included during the assay and needs to be checked.

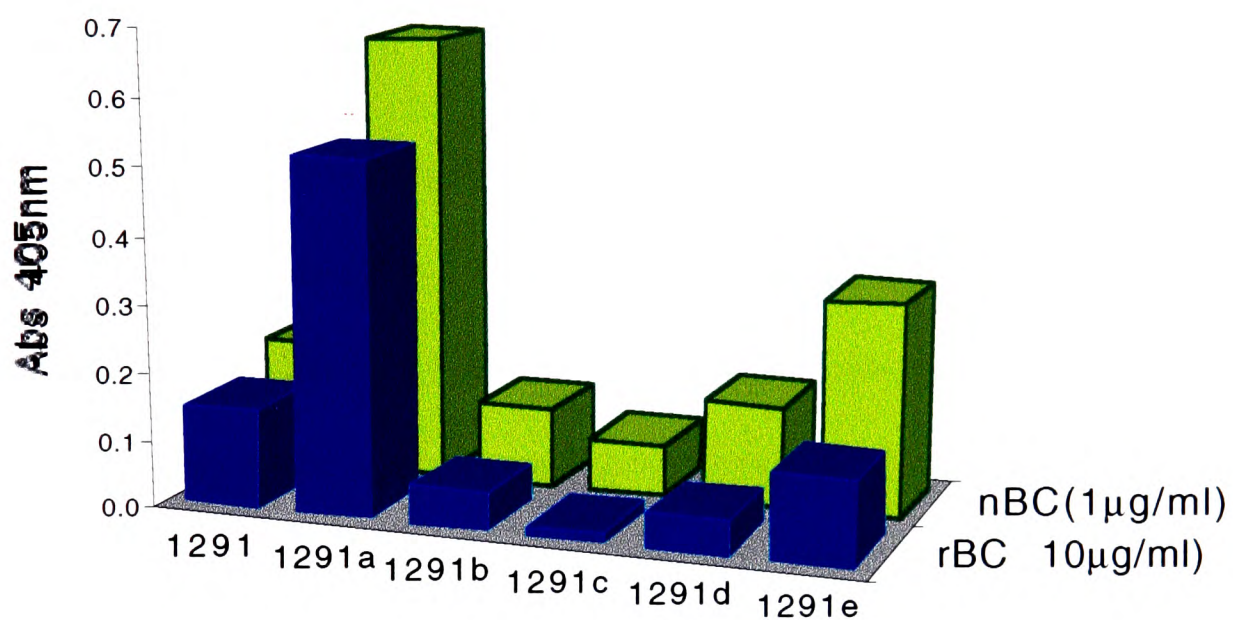

Figure 5-4: Binding of conglutinin to pyocin mutants of *Neisseria gonorrhoeae*. Pyocin mutant 1291 strains were suspended in PBS/+ and coated onto the wells. Lectins; native and recombinant conglutinin were added at a concentration of 1 µg/ml and 10 µg/ml respectively. The plates were developed with pNPP and absorbance read at 405nm.

The binding of lectin to wild type and 1291e, was significantly lower than that observed for the 1291a mutant. The binding of rBC(N/CRD) observed was lower than that of the native molecule.

5.12 SUMMARY

Pyocin mutant 1291 strain of *Neisseria gonorrhoeae* expresses lipooligosaccharide with sequential deletion of terminal hexoses. LOS from this

1291a mutant whole bacterial cell. Recombinant conglutinin showed lower affinity as compared to the native molecule. These results are in accordance with the high binding affinity of conglutinin for GlcNAc. To further elucidate the ability of lectins to augment phagocytosis of these mutants based on the preferential binding was done by using differentiated HL-60 lines (as described in section [4.5](#)). The data for this experiment also could not be collected.

5.13 DISCUSSION

This chapter describes the preliminary experiments performed to assess the ability of conglutinin (native and recombinant) and native SP-D to bind to the 1291 pyocin mutant strains of *Neisseria gonorrhoeae*. The 1291 strains are naturally occurring serum-resistant strains characterised by sequential cleavage of the terminal sugar residue on the oligosaccharide chains, i.e. each strain expresses a particular residue on its surface. The lectins are involved in the clearance of microorganisms by binding to the surface carbohydrate structures. The collectins exhibit specificity in carbohydrate recognition which is attributed to the amino acid residues present in the carbohydrate binding site (*Drickamer, 1992*). These strains provide an excellent model to study the interaction of the collectins and the microbes at the cell-surface level. BC showed preferential binding to the strain 1291a, which is consistent with the known sugar binding specificity of BC and the fact that strain 1291a presents GlcNAc on its surface, whereas other strains do not. SP-D has been shown to bind LPS from both gram-positive and gram-negative bacteria (*Kuan et al., 1992; Lim et al., 1994*). SP-D bound to all the strains but showed higher affinity for wild type, 1291a and 1291e strains, which present GlcNAc and Gal on their surfaces.

CHAPTER - 6

6 CONGLUTININ WITH COLLAGEN REGION DELETION

6.1 INTRODUCTION

The native Conglutinin is a tetrameric molecule with the trimeric subunits radiating from a central hub. The N-terminal region comprises of two invariant cysteine residues, which mediates the inter-chain disulphide linkages. The recombinant BC with collagen region deletion, cloned in pET-12a, was provided by Dr K N Sastry (Boston, USA). The presence of the N-terminal region may allow the formation of dodecamers of the head and neck regions, i.e. a tetramer of trimeric heads. This should increase the binding affinities, as compared to a single trimeric head and neck, which would then be comparable to the native molecule. It has been suggested that the collagen region may be involved in cell signalling leading to uptake of opsonised microorganisms and generation of cytokines. This construct might therefore also give an insight into the importance of the collagen region in cell signalling.

6.2 PILOT EXPRESSION STUDY

The recombinant pET-12a, was used to transform the expression host BL21(DE3). The vector contains an ompT signal that allows the expressed protein to be transported to the periplasm of the cell and may help in formation of disulphide bond formation (discussed in section 2.8.9.1).

6.2.1 CELL CULTURE

The transformed cells were inoculated in 100ml of LB medium containing ampicillin (10µg/ml) and incubated at 32°C to an A600 of 0.6. The cells were then

induced with IPTG (final conc. 0.5mM). The culture was incubated further for 2 hrs. The culture was chilled on ice for 30min and cells were then harvested by centrifugation at 10,000g for 10min.

6.2.2 PROTEIN PURIFICATION

The protein was purified using osmotic shock protocol (*Ausubel et al.*, 1999). The cell pellet was resuspended in 40ml (0.4 volume of the original culture volume) of cell lysis buffer containing 30mM Tris-Cl (pH 8.0), 20% (w/v) sucrose and EDTA (1mM final conc.) and incubated for 10min at room temperature on an end to end shaker. The suspension was then centrifuged at 10 000 x g for 10min at 4°C, removing as much of supernatant as possible. The pellet resuspended in 40 ml of ice cold 5mM MgSO₄ and incubated on ice, with constant stirring, for 10min. It was then centrifuged at 10 000 x g for 10min at 4°C, the supernatant (periplasmic fraction) contained the recombinant protein.

6.3 RESULTS

The recombinant protein was expressed in the BL21(λDE3) as a periplasmic protein. Various steps in the expression and purification were analysed by SDS/PAGE on a 15% (w/v) acrylamide gel (Fig-18). The total cell lysate of the induced cells showed recombinant fragment as a major band of approximately 28kDa under reduced conditions. The protein was localised in the periplasmic fraction, and was not visible in the cell pellet after purification by osmotic shock protocol.

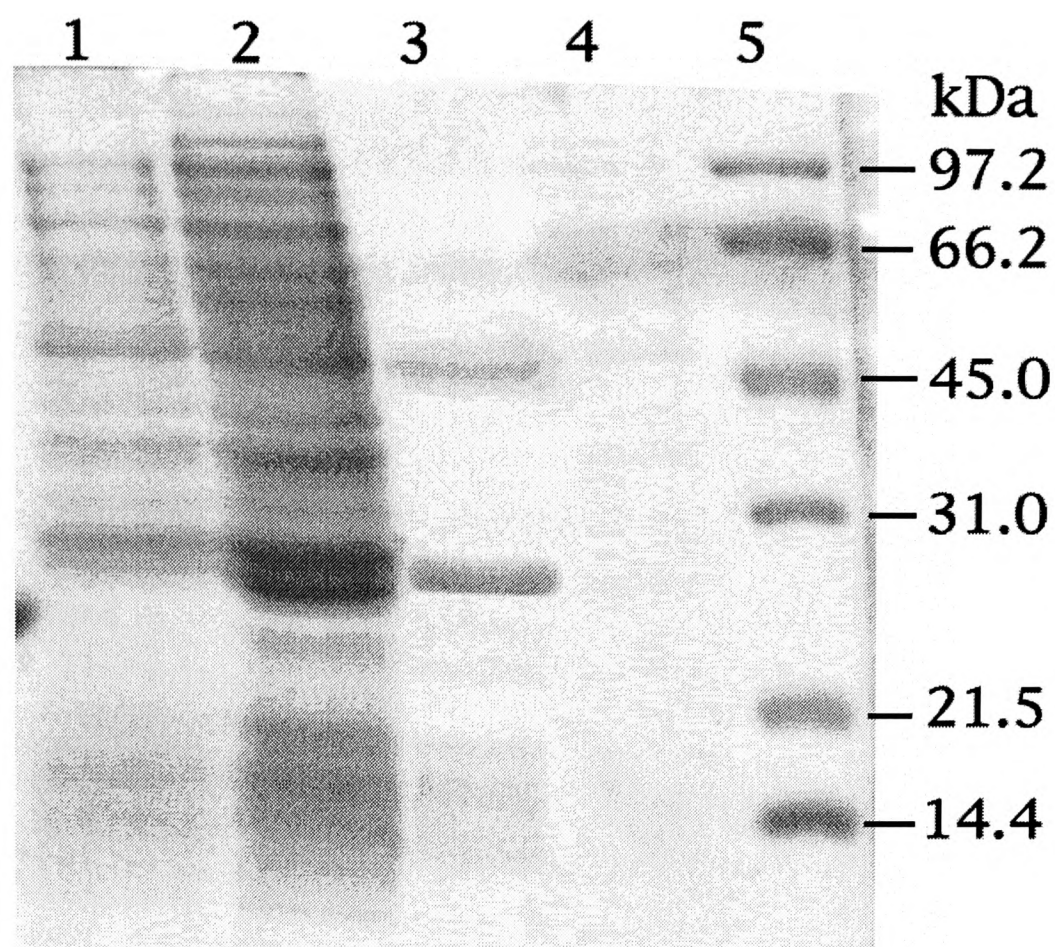

Figure 6-1: SDS-PAGE analysis of the expression and purification of recombinant conglutinin with collagen region deletion.

The recombinant protein cloned in pET-12a was expressed in BL21(DE3). The cells were induced at A_{600} of 0.6 with IPTG (final concentration 0.5mM). SDS-PAGE analysis of the expression of the recombinant conglutinin with deletion of the collagen region. Lane 1- total cell lysate of uninduced cells; lane-2: lysate of cells induced with IPTG (0.5mM); lane-3: periplasmic fraction (concentrated) containing the recombinant protein (~28KDa), after cell lysis by osmotic shock and lane-4: cell pellet.

6.4 CLONING INTO pET-32a LIC/XA

The recombinant fragment with collagen region deletion was subcloned from the initial pET-12a vector into pET-32a Xa/LIC.

6.4.1 PRIMERS

Based on the DNA sequence, the following primers were designed to clone conglutinin fragment corresponding to the residue 1 through to 351, with the deletion of collagen region encompassing residues 25-196 (Figure 1-9). The

primers were between 35-40 bases long and the temperature at which the DNA duplex should be dissociated was calculated from the base composition:

Melting temperature; $T_m = 4(G+C) + 2(A+T)$ (*Wallace and Miyada, 1987*)

The resulting temperature was used to as a guide for optimising annealing temperature used in the PCR protocol.

Sense Primer:

5' GGT ATT GAG GGT CGC GCA GAA ATG ACA ACC TTT TCT C

Anti-sense Primer:

5' AGA GGA GAG TTA GAG CCT TAT TTC TTA TAC TGA CTG AAG G

Nucleotides represented in blue are vector-specific and the target sequence specific bases are denoted in red.

Oligonucleotides were ordered from Perkin Elmer Ltd. The primers were sent as lyophilised powder and were resuspended in the autoclaved deionised double distilled water. Primers, which were sent as a solution in acetonitrile, were dried by speed vac and resuspended to a concentration of μM and stored at -20°C . The stock was diluted in water as necessary.

6.4.2 POLYMERASE CHAIN REACTION PROTOCOL

PCR was carried out on Perkins Elmer Gene Amp 2400 PCR System. Reaction mixture (50 μl) contained 0.2mM dNTPs, 10ng of forward and reverse primers, 1.0 units of *pfu* polymerase (Stratagene), 2ng of template DNA in 1x *pfu*

polymerase buffer (20mM Tris, 10mM KCl, 10 μ g/ml nuclease-free BSA, 0.1% (v/v) Triton X-100, 2mM MgCl₂, 6mM (NH₄)₂SO₄, pH 8.3). The tubes were heated to 94°C for 5min prior to PCR ensuring complete separation of the DNA strands. To amplify the target DNA following cycle parameters were used:

Strand separation	94°C	1min
Primer annealing	55°C	1min
DNA polymerisation	72°C	1min

At the end on the reaction, an additional 10min extension time at 72°C was given to ensure complete chain elongation of all PCR products.

6.4.3 T4 DNA POLYMERASE TREATMENT

The PCR amplified DNA fragment was run on 1% (w/v) agarose gel to remove dNTPs, enzymes and parent plasmid. The 550bp DNA fragment was extracted from the gel using Promega gel purification kit. The fragment was eluted in TlowE buffer (10mM Tris HCl pH 8.0, 0.1mM EDTA). Following reagents were assembled in a sterile 1.5ml microcentrifuge tube kept on ice:

4 μ l	~0.2pmol of the purified rBC(Δ coll) in TE buffer
2 μ l	10X T4 DNA polymerase buffer
2 μ l	25mM dGTP
2 μ l	100mM DTT
0.4 μ l	2.5U/ μ l T4 DNA polymerase (0.5U per 0.1pmol)
11.6 μ l	Nuclease free water

(The enzyme was added before starting the reaction.)

The reaction mixture was stirred and incubated at 22°C for 30min. The enzyme was then heat-inactivated by incubating the mixture at 75°C for 20min.

6.4.4 ANNEALING

The T4 polymerase-treated DNA fragment was then ligated into the vector pET32a Xa/LIC. 1µl of the vector and 2µl of the treated insert were incubated at 22°C for 5min. 1µl of 25mM EDTA was then added to the mixture and stirred gently with pipette tip. The reaction mixture was incubated further for 5min at 22°C.

6.4.5 TRANSFORMATION

E.coli strain NovaBlue was used for initial cloning. A single competent cell tube (50µl) was thawed on ice. 1ml of the ligation reaction was added to the competent NovaBlue cells and left on ice for 5min. The tubes were heated for exactly 30 seconds at 42°C without shaking. The tubes were then placed on ice for 2min and 250µl of room temperature SOC medium was added. The mixture was incubated at 37°C with shaking for 30min. 50ml of the transformation mixture was then plated on a LB agar plate containing 50mg/ml carbenicillin. The plates were then incubated overnight at 37°C.

6.4.6 RESULTS

The PCR of the DNA from the pET12 vector yielded an approximately 520bp fragment. This fragment was cloned into pET32a vector using ligation-independent cloning. The vector with annealed fragment was inserted into NovaBlue cells for maintaining the plasmid.

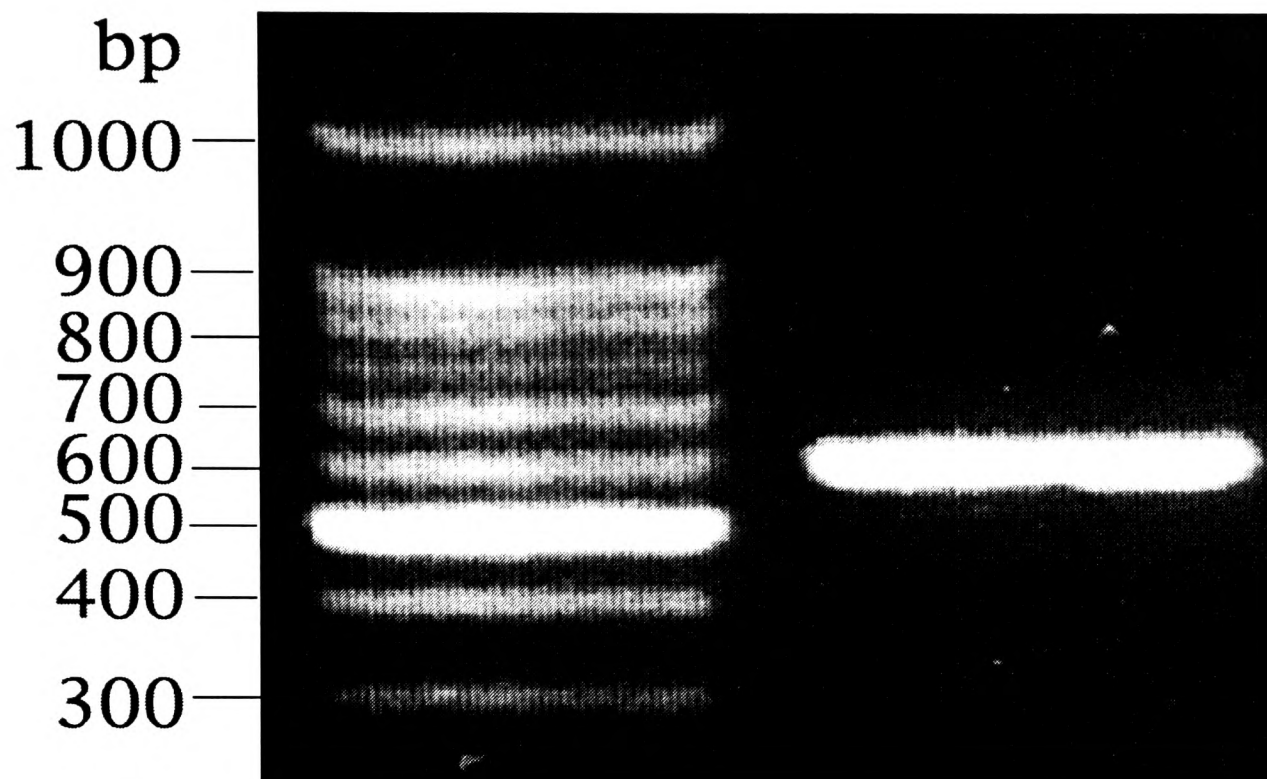

Figure 6-2: PCR amplification product of conglutinin with collagen region deletion.

The reaction mixture was run on 2% (w/v) agarose gel and visualised under UV transilluminator.

6.5 SUMMARY

The recombinant conglutinin, with the collagen region deletion, rBC(Δ coll) was expressed in BL21(DE3). The protein was purified using osmotic shock protocol and therefore was obtained at high dilution, which resulted in a low yield. The construct was subsequently amplified from its parent plasmid into the pET32a vector. As this construct would be expected to yield a tetramer of trimers the formation of correct disulphides bridges is important. The pET32 vector contains Trx•Tag encoding thioredoxin protein, which facilitates the expression of soluble protein. The expression would be ideal in AD494(DE3) cells which also express intracellular thioredoxin. Unfortunately, the lack of time did not allow for the expression of the protein and its further characterisation.

The rBC(Δ coll) has the N-terminal region which would allow the formation of dodecamers of the protein or the “tetramer of trimeric heads”, which may show affinity comparable to the native molecule and thus be better in mediating the pathogen clearance and other immune functions.

The collagen region has been suggested to be involved in transducing signal to the macrophages, important in mediating microbial clearance. The examination of the interaction of the product of this clone with the immune cells would allow this hypothesis to be tested.

6.6 DISCUSSION

Conglutinin is a tetramer of trimers has an overall cruciform shape resembling a greek cross, spanning a distance of 100nm when fully extended. The collagen region imparts flexibility to the molecule and allows aggregation of microorganisms. The recombinant BC expressed as the trimeric head comprising of neck and CRD (described in chapter-3) shows same sugar specificity as compared to the native molecule, but the binding is lower than that of the full length protein.

An attempt was made to express a recombinant fragment of BC which had the collagen-like region deleted. This would generate a tetrameric molecule similar to native conglutinin but with a shorter arm length (Figure 6-3). This recombinant protein would allow a better understanding of the role of the collagen-like region in signal transduction downstream to binding to the microbial surface and collectin receptors.

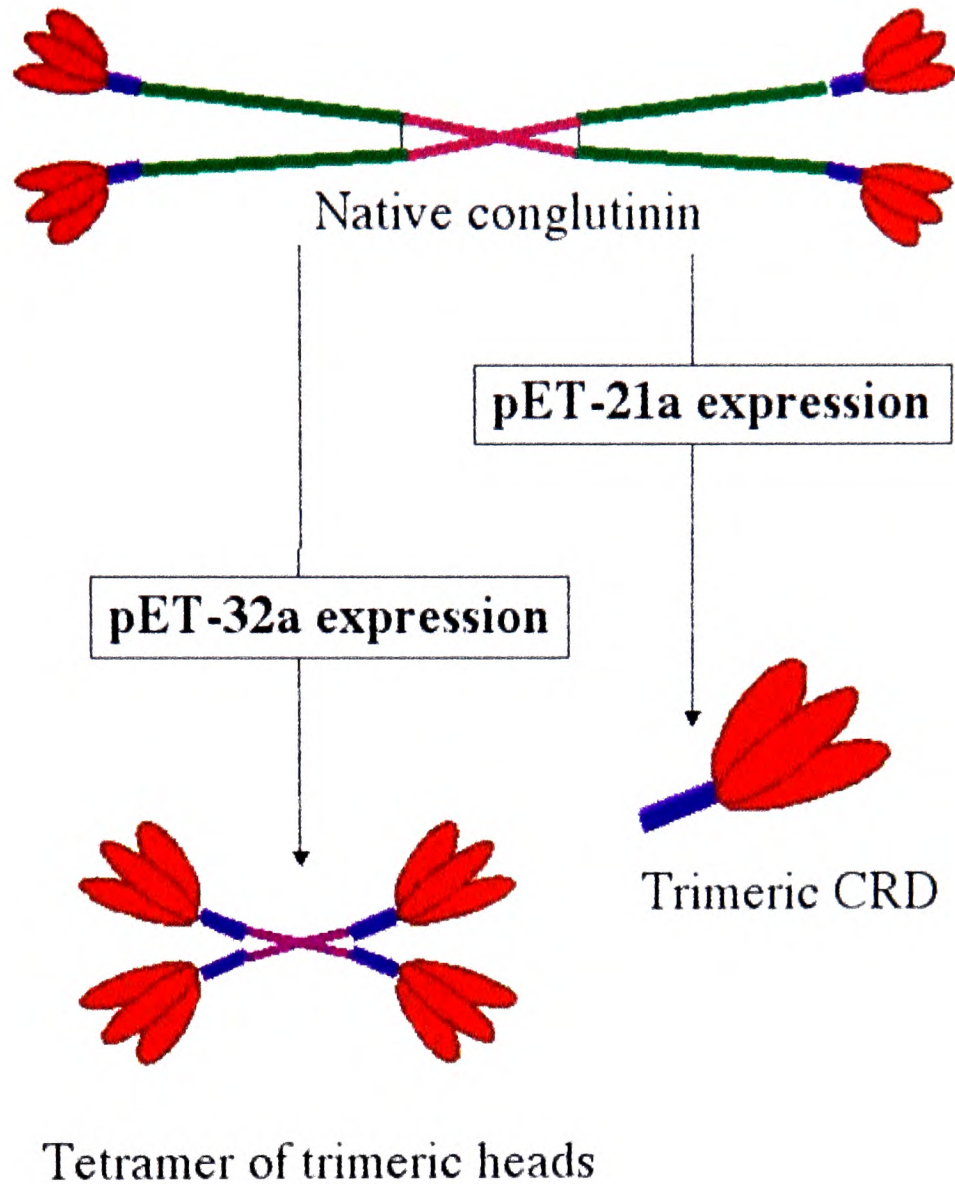

Figure 6-3: Schematic representation of recombinant conglutinin used in this study.

The neck and CRD cloned in pET-21a was expressed in *E.coli*, which formed the trimeric head. Another construct cloned in pET32a with the deletion of the collagen-like region expressed in *E.coli* strain AD494(DE3) which would probably form a tetramer of the trimeric heads, resulting in sugar binding affinity to be comparable to the native molecule.

CHAPTER - 7

7 LUNG SURFACTANT PROTEIN-D

7.1 INTRODUCTION

Surfactant protein-D shows specific interactions with various microorganisms and leukocytes, *in vitro*, suggesting that, like other collectins, it plays an important role in host immune response to microbial challenge. SP-D shows remarkable similarity to conglutinin in terms of amino acid sequence, structure and functional properties. The present study aims at elucidating the functional properties of SP-D by assessing the carbohydrate affinities and ability to recognise and subsequently facilitate the removal of pathogens, at both biological and molecular levels.

The head and neck regions of SP-D cloned by Dr Wang (*Kishore et al.*, 1996) in this lab in pMal-c2 as a fusion protein has been shown to be able to trimerise and retain its sugar binding affinities. The same clone has been used in the present study

7.2 PILOT EXPRESSION

7.2.1 SMALL-SCALE CULTURE

100 ml of rich media containing glucose (2g/l) and carbenicillin (50µg/ml) was inoculated with 1ml of overnight culture of cells containing the fusion plasmid. The cells were induced at an absorbance of 0.4 at 600nm with IPTG (0.4mM final concentration) and were further incubated for 2hrs. The culture was chilled on ice and the cells harvested at 4000 x g for 10min at 4°C. The cell pellet was resuspended in the 5ml of column buffer containing 20mM Tris-Cl, 1mM

EDTA and 20mM NaCl and the suspension was frozen overnight at -20°C. Next day, the cells were thawed on ice-water bath and sonicated with ten 30s pulses of 16µs amplitude, to lyse the cells. The sonicate was then centrifuged at 9000 x g for 20min at 4°C. The supernatant contained the protein (crude extract). 200µl of amylose resin was washed twice with the column buffer. 50µl of crude extract was added to 50µl of resin and incubated on ice for 15min. The slurry was centrifuged and washed twice with 1ml of column buffer. The resin with the bound fusion protein was resuspended in 50ml of 2X-sample buffer for SDS-PAGE analysis

7.2.2 PROTEIN PURIFICATION

A pilot expression study was done to optimise the conditions for large-scale expression and purification. The recombinant plasmid was used to transform competent NovaBlue cells for maintaining the plasmid and BL21(DE3) as the expression host.

The optimal conditions for the expression for SP-D were determined by inducing the cells at A_{600} of 0.4 and 0.6, and incubating the cells further for two to four hours.

7.3 RESULTS

The recombinant SP-D(N/CRD) cloned in pMal-C2 was expressed in BL21(DE3) cells as MBP fusion protein. Optimal expression was observed when the cells were induced with IPTG (0.4mM final conc.) at an OD of 0.4 and a further incubation for two hours.

A pilot expression was done to optimise the purification protocol for the rSP-D. Recombinant SP-D-MBP fusion protein was expressed upon induction with IPTG (Figure 7-1). The rSP-D(N/CRD) appeared as a major band of approximately 60kDa, in the total cell lysate. After sonication the protein was mainly observed in the crude extract and very little amount was seen in the insoluble matter. 50 μ l of the fusion protein was mixed with equal volume of amylose resin and some of the protein appeared in the first flow-through, which may be due to less amount of the resin available to bind the protein in the supernatant.

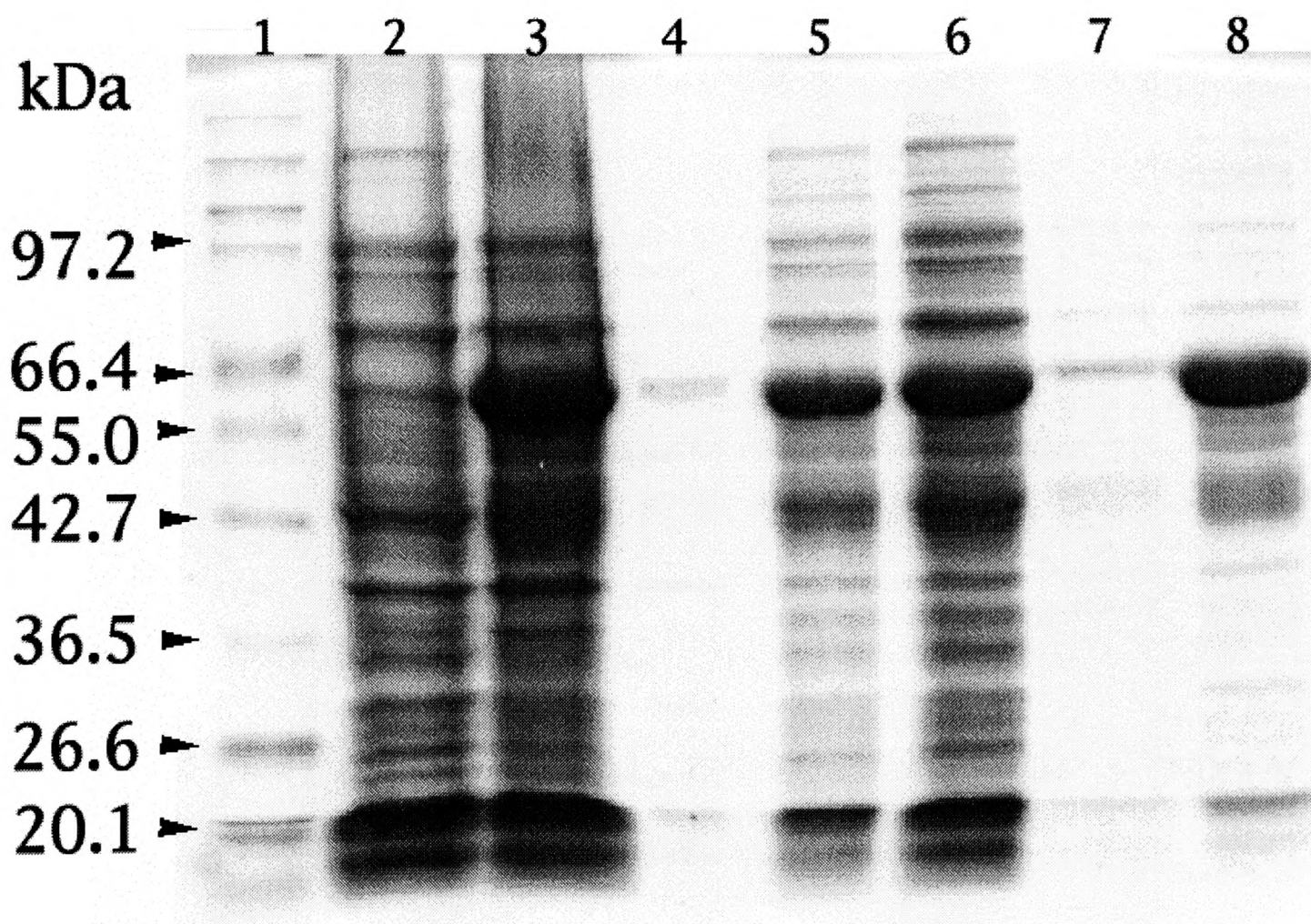

Figure 7-1: Expression of rSPD-MBP fusion protein.

Lane (1) Low molecular weight markers; (2) total cell lysate of uninduced cells, (3) cells induced with IPTG (0.4mM), (4) insoluble matter (pellet after centrifugation of the sonicate), (5) crude extract, (6) first wash from the amylose resin, (7) second wash and (8) protein bound to amylose resin.

7.4 DNA SEQUENCING

The plasmid containing the recombinant SP-D was sequenced at the William Dunn School of Pathology and Department of Biochemistry. DNA sequence encompassing seven collagen triplets was found on the N-terminal region of the recombinant protein. The α -helical neck region is the nucleation site for the formation of the collagen coil and for trimerisation of the C-terminal CRDs (*Hoppe et al.*, 1994). Collagen and collagen containing molecules have been shown to trimerise by themselves (*Dolz et al.*, 1988). Bovine conglutinin had been expressed as a recombinant fragment comprising CRD and neck regions alone. In order to compare these two structurally related members of collectin family, a similar construct was attempted to clone neck and CRD of SP-D from the full length cDNA.

The expression of the original construct was thus abandoned and the fragment was cloned again from the human SP-D cDNA using ligation independent cloning.

7.5 CLONING INTO pET-32a LIC/XA

The DNA fragment encompassing the CRD and neck regions of SP-D was cloned from the full length cDNA of SP-D (*Lu et al.*, 1992).

7.5.1 PRIMERS

Based on the DNA sequence following primers were designed to clone a recombinant hSP-D fragment comprising only neck and CRD from 199 to 349 (Figure 1-9). The primers were between 35-40 bases long and the temperature at

which the DNA duplex should be dissociated was calculated from the base composition:

Melting temperature; $T_m = 4(G+C) + 2(A+T)$ (*Wallace and Miyada, 1987*)

The resulting temperature was used to as a guide for optimising annealing temperature used in the PCR protocol.

Forward Primer:

5' GGT ATT GAG GGT CGC GAT GTT GCT TCT CTG AGG

Reverse Primer:

5' AGA GGA GAG TTA GAG CCT TAG AAC TCG CAG ACC ACA AG

Nucleotides represented in blue are vector-specific and the target sequence specific bases are denoted in red.

Oligonucleotides were obtained from Perkin Elmer Ltd. on order. The primers were sent as lyophilised powder and were resuspended in the autoclaved deionised double distilled water. Primers, which were sent as a solution in acetonitrile, were dried by speed vac and resuspended in nuclease-free water and stored at -20°C . The stock was diluted in water as necessary.

7.5.2 POLYMERASE CHAIN REACTION PROTOCOL

PCR was carried out on Perkins Elmer Cetus Gene Amp 2000, thermal cycler. Reaction mixture (50 μl) contained 0.2mM dNTPs, 10ng of forward and reverse primers, 1.0 units of *pfu* polymerase (Stratagene), 2ng of template DNA in 1x *pfu* polymerase buffer (20mM Tris, 10mM KCl, 10 $\mu\text{g/ml}$ nuclease-free BSA,

0.1% (v/v) Triton X-100, 2mM MgCl₂, 6mM (NH₄)₂SO₄, pH 8.3). The tubes were heated to 95°C for 5min prior to PCR ensuring complete separation of the DNA strands. To amplify the target DNA following cycle parameters were used:

Strand separation	94°C	30sec
Primer annealing	58°C	1min
DNA polymerisation	72°C	1min

At the end on the reaction, an additional 10 minute extension time at 72°C was given to ensure complete chain elongation of all PCR products.

7.5.3 T4 DNA POLYMERASE TREATMENT

The PCR amplified DNA fragment was run on 2% (w/v) agarose gel to remove dNTPs, enzymes and parent plasmid. The 550bp DNA fragment was extracted from the gel using Promega gel purification kit. The fragment was eluted in TlowE buffer (10mM Tris HCl pH 8.0, 0.1mM EDTA). Following reagents were assembled in a sterile 1.5ml microcentrifuge tube kept on ice:

4µl	~0.2pmol of the purified rBC(Δcoll) in TE buffer
2µl	10X T4 DNA polymerase buffer
2µl	25mM dGTP
2µl	100mM DTT
0.4µl	2.5U/µl T4 DNA polymerase (0.5U per 0.1pmol)
11.6µl	Nuclease free water

(The enzyme was added just before starting the reaction.)

The reaction mixture was stirred and incubated at 22°C for 30min. the enzyme was then heat-inactivated by incubating the mixture at 75°C for 20min.

7.5.4 ANNEALING

The T4 polymerase-treated DNA fragment was then ligated into the vector pET32a Xa/LIC. 1µl of the vector and 2µl of the treated insert were incubated at 22°C for 5min. 1µl of 25mM EDTA was then added to the mixture and stirred gently with pipette tip. The reaction mixture was incubated further for 5min at 22°C.

7.5.5 TRANSFORMATION

E.coli strain NovaBlue was used for initial cloning. A single competent cell tube (50µl) was thawed on ice. 1ml of the ligation reaction was added to the competent NovaBlue cells and left on ice for 5min. The tubes were heated for exactly 30 seconds at 42°C without shaking. The tubes were then placed on ice for 2min. 250ml of room temperature SOC medium was then added into the tube and incubated at 37°C with shaking for 30min. 50ml of the transformation mixture was then plated on a LB agar plate containing 50mg/ml carbenicillin. The plates were then incubated overnight at 37°C.

7.5.6 RESULTS

The recombinant fragment comprising CRD and neck regions of human SP-D were cloned from cDNA. The DNA fragment was run on agarose gel and visualised under UV. The 500bp fragment (Figure 7-2) resulting from this PCR was then treated further for ligating into pET-32a Xa/LIC vector.

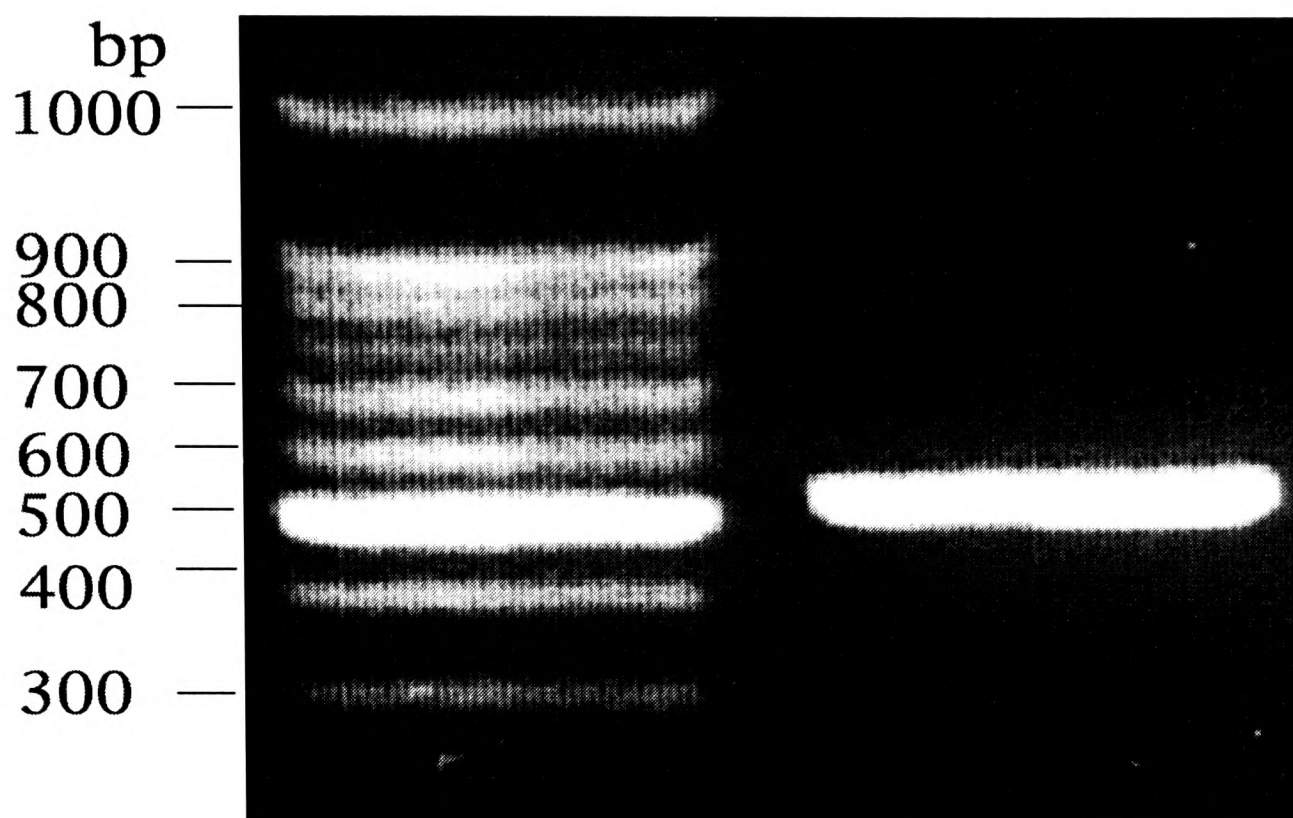

Figure 7-2: PCR-amplified DNA fragment of SP-D comprising CRD and neck regions.

100bp DNA markers were used to determine the size of the product obtained. The PCR-amplified product was a 500bp fragment encompassing CRD and neck regions of human SP-D.

NovaBlue cells were transformed with the DNA fragment and pET vector ligation mixture. The plates were incubated overnight and next day there were approximately fifty colonies on the plate.

7.6 SUMMARY

The recombinant SP-D had been expressed as a fusion protein with MBP in *E.coli*. The DNA sequence was verified before proceeding further and seven extra Gly-X-Y triplets were observed as described in section 7.4 above. It was then attempted to clone the fragment in pET32a Xa/LIC using ligation-independent cloning. The amplified DNA was annealed into the vector and transformed into *recA*⁻ Novablue cells to maintain the plasmid. The protein will be expressed in *E.coli* strain AD494(DE3). pET32a contains Trx•Tag, which facilitates the

formation of disulphide bonds in the cytoplasm. Due to lack of time the transformation of the expression strain and subsequent expression of the protein could not be completed.

7.7 DISCUSSION

SP-D shows a greater similarity to BC than to any other member of the collectin family. Comparison of their amino acid sequences reveal 79% identity. The two lectins have the same length N-terminal and collagen-like region but the CRD of SP-D is shorter by two amino acids. The additional amino acids in BC are present in the carbohydrate binding site, which provides a mechanism for the difference SP-D is specific for α -glucosyl residues (*Persson et al.*, 1990; *Lu et al.*, 1992).

To elaborate the roles of neck and CRD of SP-D and to compare the biological functions with corresponding recombinant fragment of BC, a previously cloned recombinant SP-D was expressed as a MBP fusion protein. This construct was later found to contain the sequences from the collagen-like region. Therefore, to do just comparison between BC and SP-D, the fragment (Figure 1-9) encompassing the neck and CRD sequence only, was cloned into pET32a vector. This chapter describes the cloning of this recombinant fragment of SP-D comprising neck and CRD. This recombinant fragment, like rBC(N/CRD) would be a trimer and retain the carbohydrate binding specificity similar to the native SP-D. The comparison of the functional properties of the two recombinant fragments would provide a greater insight into structure/function relationship. Recent studies have shown an increased anti-influenza activity of chimeric proteins comprising

neck and CRD of BC and collagen-like region and N-terminus of SP-D, and N/CRD of MBL and collagenous region and N-terminus of SP-D (*Hartshorn et al., 2000; Hartshorn et al., 2000; White et al., 2000*). This is interesting as SPD(N/CRD) expressed by the same group exhibits greatly reduced haemagglutinating activity (*Hartshorn et al., 1996; Hartshorn et al., 1997*). The comparison of the recombinant fragments of BC and SP-D and by swapping the domains between the two collectins would provide a greater understanding of the functional roles of the two domains.

8 GENERAL DISCUSSION

Collectins represent an important recognition mechanism for the oligosaccharides at the cell surfaces, attached to the circulating proteins and in the extracellular matrix (*Sastry and Ezekowitz, 1993; Hoppe and Reid, 1994*). Binding of specific sugar structures by these lectins mediate biological events, such as cell-cell adhesion, serum glycoprotein turnover and innate immune responses to potential pathogens (*Holmskov et al., 1994; Hoppe and Reid, 1994*) (*Weis et al., 1998*). The first step to the clearance of the pathogen is the recognition of the terminal elaborations on the surface of the microorganisms.

Collectins are C-type lectins characterised by four domains: an N-terminal cysteine-rich domain, followed by collagen-like region linked to C-terminal carbohydrate-recognition domain (CRD) via a α -helical neck region. CRD shows considerable specificity in binding carbohydrates (*Drickamer, 1992; Elgavish and Shaanan, 1997*). The proteins belonging to this group include: mannan-binding lectin (MBL), lung surfactant protein-A (SP-A), lung surfactant protein-D (SP-D), bovine conglutinin (BC), collectin-43 (CL-43) and recently identified CL-L1. These proteins show similarity in their domain organisation and overall three-dimensional structure. The C-type lectin domains in the globular heads have the capacity to recognise a range of specific carbohydrate structures present on the surface of the pathogens commonly associated with infections in blood, lung and amniotic fluid (*Reid and Turner, 1994*). Selective binding of sugars by these domains is essential for glycoprotein clearance, cell-cell adhesion and pathogen neutralisation.

A recombinant fragment of bovine conglutinin (*Wang et al.*, 1995) comprising the CRD and neck regions, cloned in a modified pET-21 vector, has been expressed in the *E. coli* strain BL21(DE3)pLysS. The recombinant protein formed a homotrimer after the refolding procedure, as determined by size-exclusion chromatography. The ability of the recombinant protein to form a trimer further confirms the ability of the neck region to trimerise the CRDs (*Hoppe et al.*, 1994; *Kishore et al.*, 1996). The recombinant fragment retained its calcium-dependent sugar binding specificity as determined by the solid-phase binding assay against GlcNAc and mannan, which was inhibited in presence of competing sugars. The dissociation constants were calculated using BIAcore as 0.6 μ M for mannan and 2.4 μ M for iC3b. The competitive sugar inhibition assay revealed GlcNAc as the most efficient inhibitor of binding of conglutinin to mannan as well as iC3b.

The recombinant and native conglutinin bound to the LPS derived from the gram-negative bacteria, but the binding was significantly lower than that observed for native human SP-D. This would indicate the importance of the role of SP-D in recognising the pathogens in the pulmonary milieu. The monosaccharide preferences alone do not account for binding characteristics of lectins to bacteria. The affinity of lectins towards the monosaccharides is relatively low (in mM range), but they are able to elicit specific binding to their natural targets, usually branched carbohydrates. While the ultimate selectivity of lectins is probably attained by multivalency mechanisms (multimerisation of the subunit), a major discriminatory factor in carbohydrate recognition is the primary monosaccharide specificity, which is usually indicative of the particular branched carbohydrate to be recognised by the lectin.

The important step in pathogen neutralisation is the presentation of the pathogen to the immune cells. The lectins have been shown to act as opsonins and/or cause aggregation, thereby initiating phagocytosis of the pathogens. The native SP-D was most efficient in aggregating bacteria (*i.e.* *E. coli* strain Y1088) as determined by a macroscopic sedimentation assay (*Kuan et al.*, 1992). Conglutinin was also able to agglutinate the bacteria albeit not as well as SP-D. It was very surprising to find that the recombinant conglutinin, which consists only of the CRD and neck regions, was also able to cause aggregation and sedimentation to a similar extent that shown by the native conglutinin molecule. The agglutination was calcium-dependent and was inhibitable by competing sugar residues. Essentially one would assume that aggregation would involve cross-linking of the bacterial cells via the multivalent lectin heads. Therefore, it is quite possible that these lectin domains might use another mechanism as well to cause aggregation and would be worthwhile to investigate this behaviour further.

The binding of these lectins to whole bacterial cells (*K. pneumonia* and *S. aureas*) and zymosan (*S. cerevisiae*) was tested by ELISA. Conglutinin did not show much binding to the bacteria in comparison to native SP-D. However, they showed high binding affinity to zymosan.

The ability of conglutinin and SP-D to mediate phagocytosis was further investigated using differentiated HL-60 cells. It would be interesting to know the role of recombinant conglutinin in mediating phagocytosis especially when it is able to induce aggregation of the bacterial cells. Unfortunately, the data could not be recorded.

The pyocin mutant 1291 strain, 1291 wild type and series 1291a-e, of *Neisseria gonorrhoeae* expresses LOS which are sequentially deficient in the terminal sugar residues. The ability of conglutinin to bind these mutant strains was tested against the LOS isolated from the strains and whole bacterial cells. The LOS binding was assayed by ELISA for both native and recombinant conglutinin. 1291a strain, which presents N-acetyl glucosamine as its terminal sugar residue, showed highest binding to conglutinin. Some binding to other strains was also observed when tested against isolated LOS, but not in case of whole cells. This may be due to the orientation of sugars on the surface of the cells as opposed to isolated LOS immobilised on a surface. It is however of great interest how this selectivity of strain be utilised in understanding the cellular interactions.

SP-D has been shown to be present in pulmonary (*Rust et al.*, 1991) and gastric (*Fisher and Mason*, 1995) mucosal epithelium. It would be interesting to investigate if it is expressed in the mucosal lining of the genito-urinary tract as well, which would be a potential candidate for immunotherapy, since conglutinin is of bovine origin which makes it less suitable as a vaccine candidate.

Serum resistance in *Neisseria* is in part imparted by the increased inactivation of C3 to iC3b, by factor H, which allows the gonococci to evade complement-mediated killing (discussed in section 5.6). Bovine conglutinin shows high affinity for iC3b and the binding results in the recognition by the receptors present on the surface of the phagocytes and PMNs. This recognition of iC3b-coated gonococci by conglutinin could present a mechanism for the clearance of serum-resistant gonococci clearance. This hypothesis needs to be examined by bactericidal assays with patients' serum in presence of conglutinin (native or

recombinant). The model of *Neisseria gonorrhoeae* provides a fruitful resource for the study of a variety of basic molecular processes. The findings are not only relevant to gonococci, but in the broader sense to other mucosal pathogens.

The collectins have been shown to bind to the C1q/collectin receptors via their collagen regions and are thought to be involved the signal transduction mechanism. To describe the role of the collagen region in downstream effector function a recombinant fragment of conglutinin, which has the deletion of the collagen region, has been cloned into a pET-32a Xa/LIC vector. The resulting protein would presumably be a tetramer of trimers, with multivalency similar to the native molecule but would have shorter arm length. The examination of the recombinant protein would allow greater understanding of the role of collagen in lectin interaction. This would also be a useful tool for mediating recognition and subsequent clearance of the pathogens.

SP-D showed high binding to *E.coli* and *S. aureus* as compared to that exhibited by BC, as assessed by the whole cell binding ELISA. It would be helpful to study these interactions with a construct similar to the recombinant conglutinin rBC(N/CRD). Therefore, the region corresponding to the CRD and neck domains has been cloned for expression in *E. coli*. The examination of interaction of this recombinant protein would allow a greater understanding with respect to the function in specific environments.

The crystal structure the CRD of the BC (Appendix: F) has been solved since the submission of this thesis. The structure comprises of two alpha helices and a β -pleated sheet (Fig-A), which is characteristic of the collectin family. The

calcium binding sites in the CRD are occupied by water molecules in the structure (Fig-B). Three residues 318-320 are disordered and are not drawn in the figure. It is quite possible that calcium is essential for the stability of these residues comprising the carbohydrate recognition site. The structure shows remarkable similarity to that of SP-D (Fig-C) (*Hakansson et al.*, 1999) and MBL (Fig-D) (*Weis et al.*, 1992). However the conglutinin shows different sugar specificity compared to the other two lectins, having highest affinity for GlcNAc in comparison to the two lectins. The difference could be addressed by the different structure at this site, which needs to be confirmed with new crystal data. The amino acid sequence analysis revealed that the entire neck region was missing, probably due to proteolytic degradation, resulting in the presence of only single CRD, further emphasising the importance of the neck region in trimerisation of the CRDs. The crystal formed in 2M ammonium sulphate at pH 4.6. The low pH would be responsible for the inability of the CRD to bind calcium or N-acetyl glucosamine. Further trials are underway to crystallise the trimeric recombinant BC CRDs at neutral pH and also bound to GlcNAc. The structure, once available, would allow a better understanding of sugar specificities, which to be governed by the residues comprising the binding site.

TABLE OF FIGURES

<i>Figure 1-1: Schematic representation of the overall structures of galectins.....</i>	<i>11</i>
<i>Figure 1-2: Schematic representation of the structural organisation of ficolins.</i>	<i>13</i>
<i>Figure 1-3: Domain organisation of the members of the C-type lectin family.....</i>	<i>17</i>
<i>Figure 1-4: Domain organisation of the macrophage mannose receptor.</i>	<i>24</i>
<i>Figure 1-5: Summary of C-Type Lectin Domain (CTLN) evolution.</i>	<i>27</i>
<i>Figure 1-6: Schematic representation of formation and relationship of collectins.....</i>	<i>30</i>
<i>Figure 1-7: Schematic representation of interactions of collectins with complement components and their physiological significance.</i>	<i>37</i>
<i>Figure 1-8: Schematic representation of the structural features of the Mannan-binding lectin.</i>	<i>40</i>
<i>Figure 1-9: Sequence comparison of Bovine Conglutinin and Surfactant Protein-D.....</i>	<i>46</i>
<i>Figure 1-10: Diagrammatic representation of the components of the host immune system active in the pulmonary system.</i>	<i>54</i>
<i>Figure 1-11: Schematic linear representation of the domain structure of the surfactant protein monomers.....</i>	<i>57</i>
<i>Figure 1-12: Schematic representation of a hypothetical scheme of the metabolic pathways of surfactant secretion uptake, clearance and reutilization [Wright, 1997 #58].....</i>	<i>59</i>
<i>Figure 1-13: Structural organisation and summary of the functional properties attributed to various domains of the Lung Surfactant-A.</i>	<i>66</i>
<i>Figure 1-14: Morphology of large aggregate (LA) surfactant of the SP-A knockout mice as seen under electron microscope.....</i>	<i>68</i>
<i>Figure 1-15: A model for the actions of SP-B on surfactant lipids.....</i>	<i>70</i>
<i>Figure 1-16: Ribbon model of the overall structure of lung Surfactant Protein-D.....</i>	<i>75</i>

<i>Figure 1-17: Electron micrograph of an alveolar region highlighting the structural changes as observed in the lung Surfactant Protein-D null mouse.</i>	81
<i>Figure 1-18: Comparative genomic organisation of Bovine Conglutinin and human lung Surfactant Protein-D.</i>	84
<i>Figure 1-19: Alignments and phylogenetic tree of CL-L1 and several collectins.</i>	86
<i>Figure 2-1: Control systems in pET expression systems.</i>	94
<i>Figure 2-2: Principle of SPR.</i>	102
<i>Figure 2-3: Schematic sensorogram; showing association, equilibrium and dissociation phases.</i>	103
<i>Figure 2-4: BIA coupling chemistries.</i>	105
<i>Figure 2-5: The SPR angle is sensitive to the mass concentration of the molecules close to the sensor chip surface.</i>	107
<i>Figure 3-1: SDS-PAGE analysis of recombinant Bovine Conglutinin expressed in BL21(DE3).</i>	113
<i>Figure 3-2: SDS-PAGE analysis of the induction of rBC(N/CRD) in BL21(DE3)pLysS.</i>	114
<i>Figure 3-3: Expression of recombinant Bovine Conglutinin.</i>	119
<i>Figure 3-4: Expression and dialysate analysis of rBC(N/CRD).</i>	120
<i>Figure 3-5: Elution profile of the rBC(N/CRD) on mannan-agarose column.</i>	121
<i>Figure 3-6: SDS-PAGE analysis of the fractions from Mannan-agarose column.</i>	121
<i>Figure 3-7: Elution profile of the rBC(N/CRD) on Q-Sepharose column.</i>	122
<i>Figure 3-8: Elution profile of the recombinant BC(N/CRD) on Mono-Q column.</i>	123
<i>Figure 3-9: Gel-filtration chromatography elution profile of rBC(N/CRD).</i>	124
<i>Figure 3-10: HPLC profile of recombinant fragment of Bovine Conglutinin.</i>	125
<i>Figure 3-11: Mass spectrometric analysis of the HPLC peaks C&D.</i>	126
<i>Figure 3-12: BIA analysis of the Superdex75 fractions.</i>	130
<i>Figure 3-13: Binding of conglutinin to solid-phase mannan.</i>	131

<i>Figure 3-14: Binding to solid-phase N-acetyl glucosamine</i>	131
<i>Figure 3-15: Competitive inhibition of binding by N-acetyl glucosamine</i>	132
<i>Figure 3-16: Assessment of carbohydrate-binding property of biotinylated rBC(N/CRD)</i>	133
<i>Figure 3-17: BIAanalysis of interaction of recombinant conglutinin fragment, comprising of neck and CRD, with Mannan</i>	136
<i>Figure 3-18: BIAanalysis of interaction of recombinant Conglutinin fragment, comprising of neck and CRD, complement component iC3b</i>	137
<i>Figure 3-19: Binding to LPS from gram-negative bacteria by Conglutinin</i>	140
<i>Figure 3-20: Crystals of the recombinant Bovine Conglutinin</i>	142
<i>Figure 4-1: Macroscopic Aggregation of E.coli strain Y1088</i>	151
<i>Figure 4-2: Time-dependent nSP-D-mediated Agglutination of E. coli Strain Y1088</i>	152
<i>Figure 4-3: Time-dependent nBC-mediated Agglutination of E. coli Strain Y1088</i>	152
<i>Figure 4-4: Time-dependent rBC-mediated Agglutination of E. coli Strain Y1088</i>	153
<i>Figure 4-5: Photomicrographs of the Y1088 bacterial cell suspension</i>	154
<i>Figure 4-6: Binding of lectins to immobilised bacterial cells</i>	157
<i>Figure 4-7: Flow Cytometric Analysis of Differentiation of HL-60 cells by ATRA</i>	160
<i>Figure 4-8: Flow Cytometric Analysis of Differentiation of HL-60 cells by PMA</i>	161
<i>Figure 5-1: Structural model of the Lipooligosaccharide (LOS) structure</i>	173
<i>Figure 5-2: Structure of the lipooligosaccharides of the pyocin-resistant 1291 series</i>	181
<i>Figure 5-3: Binding of conglutinin and SP-D to gonococcal LOS</i>	192
<i>Figure 5-4: Binding of conglutinin to pyocin mutants of Neisseria gonorrhoeae</i>	194
<i>Figure 6-1: SDS-PAGE analysis of the expression and purification of recombinant conglutinin with collagen region deletion</i>	198
<i>Figure 6-2: PCR amplification product of conglutinin with collagen region deletion</i>	202

Figure 6-3: Schematic representation of recombinant conglutinin used in this study..... 204

Figure 7-1: Expression of rSP-D-MBP fusion protein..... 207

Figure 7-2: PCR-amplified DNA fragment of SP-D comprising CRD and neck regions. 212

TABLE OF TABLES

<i>Table 1-1: Examples of the potential lectin-reactive site on the surface of various microorganisms.</i>	5
<i>Table 1-2: Animal lectins and families (adapted from [Powell, 1995 #345])</i>	7
<i>Table 1-3: Summary of morphological features of the members of collectin family. (Modified from [Drickamer, 1993 #313])</i>	21
<i>Table 1-4: Principle structural features seen in collectins and complement component C1q.</i>	28
<i>Table 1-5: Factors that affect the secretion and clearance of surfactant.</i>	60
<i>Table 1-6: Biological ligands for SP-A</i>	64
<i>Table 1-7: Transmembrane receptors and binding proteins for soluble defence collagens. [Tenner, 1999 #417].</i>	82
<i>Table 1-8: Chromosomal localisation of C1q and members of collectin family</i>	85
<i>Table 3-1: Saccharide specificities of rBC(N/CRD)</i>	146

BIBLIOGRAPHY

REFERENCES

- Anders E M, Hartley C A, Reading P C and Ezekowitz R A (1994). Complement-dependent neutralization of influenza virus by a serum mannose-binding lectin. *J Gen Virol* **75 Pt 3**: 615-622.
- Apicella M A, Westerink M A, Morse S A, Schneider H, Rice P A and Griffiss J M (1986). Bactericidal antibody response of normal human serum to the lipooligosaccharide of *Neisseria gonorrhoeae*. *J-Infect-Dis.* 1986 Mar; **153 3**: 520-526.
- Arar C, Carpentier V, Le Caer J P, Monsigny M, Legrand A and Roche A C (1995). ERGIC-53, a membrane protein of the endoplasmic reticulum-Golgi intermediate compartment, is identical to MR60, an intracellular mannose-specific lectin of myelomonocytic cells. *J Biol Chem* **270 8**: 3551-3553.
- Ariizumi K, Shen G L, Shikano S, Ritter R, 3rd, Zukas P, Edelbaum D, Morita A and Takashima A (2000). Cloning of a second dendritic cell-associated C-type lectin (dectin-2) and its alternatively spliced isoforms. *J Biol Chem* **275 16**: 11957-11963.
- Ariizumi K, Shen G L, Shikano S, Xu S, Ritter I, Kumamoto T, Edelbaum D, Morita A, Bergstresser P R and Takashima A (2000). Identification of a novel, dendritic cell-associated molecule, Dectin- 1, by subtractive cDNA cloning. *J Biol Chem* : .
- Aslanidis C and de Jong P J (1990). Ligation-independent cloning of PCR products (LIC-PCR). *Nucleic Acids Res* **18 20**: 6069-6074.
- Aubry J P, Pochon S, Gauchat J F, Nueda-Marin A, Holers V M, Graber P, Siegfried C and Bonnefoy J Y (1994). CD23 interacts with a new functional extracytoplasmic domain involving N-linked oligosaccharides on CD21. *J Immunol* **152 12**: 5806-5813.
- Aubry J P, Pochon S, Graber P, Jansen K U and Bonnefoy J Y (1992). CD21 is a ligand for CD23 and regulates IgE production. *Nature* **358 6386**: 505-507.
- Ausubel F M, Brent R and Kingston R E (1999). "Currents protocols in molecular biology" , John Wiley & Sons.
- Ayala P, Lin L, Hopper S, Fukuda M and So M (1998). Infection of epithelial cells by pathogenic neisseriae reduces the levels of multiple lysosomal constituents. *Infect Immun* **66 10**: 5001-5007.
- Baatrup G, Thiel S, Isager H, Svehag S E and Jensenius J C (1987). Demonstration in human plasma of a lectin activity analogous to that of bovine conglutinin. *Scand J Immunol* **26 4**: 355-361.
- Baatz J E, Elledge B and Whitsett J A (1990). Surfactant protein SP-B induces ordering at the surface of model membrane bilayers. *Biochemistry* **29 28**: 6714-6720.

- Badwey J A and Karnovsky M L (1980). Active oxygen species and the functions of phagocytic leukocytes. *Annu Rev Biochem* **49** : 695-726.
- Bardwell J C (1994). Building bridges: disulphide bond formation in the cell. *Mol Microbiol* **14** **2**: 199-205.
- Bardwell J C, McGovern K and Beckwith J (1991). Identification of a protein required for disulfide bond formation in vivo. *Cell* **67** **3**: 581-589.
- Barondes S H (1988). Bifunctional properties of lectins: lectins redefined. *Trends Biochem Sci* **13** **12**: 480-482.
- Barondes S H, Cooper D N, Gitt M A and Leffler H (1994). Galectins. Structure and function of a large family of animal lectins. *J Biol Chem* **269** **33**: 20807-20810.
- Bates E E, Fournier N, Garcia E, Valladeau J, Durand I, Pin J J, Zurawski S M, Patel S, Abrams J S, Lebecque S, Garrone P and Saeland S (1999). APCs express DCIR, a novel C-type lectin surface receptor containing an immunoreceptor tyrosine-based inhibitory motif. *J Immunol* **163** **4**: 1973-1983.
- Beavil A J, Edmeades R L, Gould H J and Sutton B J (1992). Alpha-helical coiled-coil stalks in the low-affinity receptor for IgE (Fc epsilon RII/CD23) and related C-type lectins. *Proc Natl Acad Sci U S A* **89** **2**: 753-757.
- Bella J, Eaton M, Brodsky B and Berman H M (1994). Crystal and molecular structure of a collagen-like peptide at 1.9 Å resolution [see comments]. *Science* **266** **5182**: 75-81.
- Benne C A, Kraaijeveld C A, van Strijp J A, Brouwer E, Harmsen M, Verhoef J, van Golde L M and van Iwaarden J F (1995). Interactions of surfactant protein A with influenza A viruses: binding and neutralization. *J Infect Dis* **171** **2**: 335-341.
- Benson B, Hawgood S, Schilling J, Clements J, Damm D, Cordell B and White R T (1985). Structure of canine pulmonary surfactant apoprotein: cDNA and complete amino acid sequence. *Proc Natl Acad Sci U S A* **82** **19**: 6379-6383.
- Bertram M A, Griffiss J M and Broud D D (1976). Response to antigenic determinants of *Neisseria meningitidis* lipopolysaccharide investigated with a new radioactive antigen-binding assay. *J Immunol* **116** **3**: 842-846.
- Bettler B, Texido G, Raggini S, Ruegg D and Hofstetter H (1992). Immunoglobulin E-binding site in Fc epsilon receptor (Fc epsilon RII/CD23) identified by homolog-scanning mutagenesis. *J Biol Chem* **267** **1**: 185-191.
- Beyer E C, Zweig S E and Barondes S H (1980). Two lactose binding lectins from chicken tissues. Purified lectin from intestine is different from those in liver and muscle. *J Biol Chem* **255** **9**: 4236-4239.
- Bieber T, Rieger A, Stingl G, Sander E, Wanek P and Strobel I (1992). CD69, an early activation antigen on lymphocytes, is constitutively expressed by human epidermal Langerhans cells. *J Invest Dermatol* **98** **5**: 771-776.

- Bischoff J and Lodish H F (1987). Two asialoglycoprotein receptor polypeptides in human hepatoma cells. *J Biol Chem* **262** **24**: 11825-11832.
- Blake M S and Gotschlich E C (1982). Purification and partial characterization of the major outer membrane protein of *Neisseria gonorrhoeae*. *Infect Immun* **36** **1**: 277-283.
- Blake M S, Gotschlich E C and Swanson J (1981). Effects of proteolytic enzymes on the outer membrane proteins of *Neisseria gonorrhoeae*. *Infect Immun* **33** **1**: 212-222.
- Blasco E, Barra A, Nicolas M, Lecron J C, Wijdenes J and Preud'homme J L (1995). Proliferative response of human CD4+ T lymphocytes stimulated by the lectin jacalin. *Eur J Immunol* **25** **7**: 2010-2018.
- Blau H, Riklis S, Kravtsov V and Kalina M (1994). Secretion of cytokines by rat alveolar epithelial cells: possible regulatory role for SP-A. *Am J Physiol* **266** **2 Pt 1**: L148-155.
- Body D R (1971). The phospholipid composition of pig lung surfactant. *Lipids* **6** **9**: 625-629.
- Boggaram V, Qing K and Mendelson C R (1988). The major apoprotein of rabbit pulmonary surfactant. Elucidation of primary sequence and cyclic AMP and developmental regulation. *J Biol Chem* **263** **6**: 2939-2947.
- Bordet J and Streng O (1909). Les phénomènes d'absorption de la congutinine du serum de boeuf. *Ann-Inst-Pasteur* **49** : 260-276.
- Borron P, McCormack F X, Elhalwagi B M, Chroneos Z C, Lewis J F, Zhu S, Wright J R, Shepherd V L, Possmayer F, Inchley K and Fraher L J (1998). Surfactant protein A inhibits T cell proliferation via its collagen-like tail and a 210-kDa receptor. *Am J Physiol* **275** **4 Pt 1**: L679-686.
- Borron P, McIntosh J C, Korfhagen T R, Whitsett J A, Taylor J and Wright J R (2000). Surfactant-associated protein A inhibits LPS-induced cytokine and nitric oxide production in vivo. *Am J Physiol Lung Cell Mol Physiol* **278** **4**: L840-847.
- Borron P J, Crouch E C, Lewis J F, Wright J R, Possmayer F and Fraher L J (1998). Recombinant rat surfactant-associated protein D inhibits human T lymphocyte proliferation and IL-2 production. *J Immunol* **161** **9**: 4599-4603.
- Botas C, Poulain F, Akiyama J, Brown C, Allen L, Goerke J, Clements J, Carlson E, Gillespie A M, Epstein C and Hawgood S (1998). Altered surfactant homeostasis and alveolar type II cell morphology in mice lacking surfactant protein D. *Proc Natl Acad Sci USA* **95** **20**: 11869-11874.
- Boyd W C (1970). Lectins. *Ann N Y Acad Sci* **169** **1**: 168-190.
- Boyd W C and Shapleigh B S (1954). Diagnosis of subgroups of blood type groups A and AB by use of plant agglutinin (lectins). *J Lab Clin Med* **44** : 235-237.

- Bradford M M (1976). A rapid and sensitive method for the quantitation of microgram quantities of protein utilizing the principle of protein-dye binding. *Anal Biochem* **72** : 248-254.
- Brooks G F and Lammel C J (1989). Humoral immune response to gonococcal infections. *Clin Microbiol Rev* **2 Suppl** : S5-10.
- Brown E J (1991). Complement receptors and phagocytosis. *Curr Opin Immunol* **3** **1**: 76-82.
- Brown E J, Gaither T A, Hammer C H, Hosea S W and Frank M M (1982). The use of conglutinin in a quantitative assay for the presence of cell-bound C3bi and evidence that a single molecule of C3bi is capable of binding conglutinin. *J Immunol* **128** **2**: 860-865.
- Brummer J, Neumaier M, Gopfert C and Wagener C (1995). Association of pp60c-src with biliary glycoprotein (CD66a), an adhesion molecule of the carcinoembryonic antigen family downregulated in colorectal carcinomas. *Oncogene* **11** **8**: 1649-1655.
- Bruns G, Stroh H, Veldman G M, Latt S A and Floros J (1987). The 35 kd pulmonary surfactant-associated protein is encoded on chromosome 10. *Hum Genet* **76** **1**: 58-62.
- Buck P and Rest R F (1981). Effects of human neutrophil granule extracts on macromolecular synthesis in *Neisseria gonorrhoeae*. *Infect Immun* **33** **2**: 426-433.
- Bulleid N J (1993). Protein disulfide-isomerase: role in biosynthesis of secretory proteins. *Adv Protein Chem* **44** : 125-150.
- Cai G Z, Griffin G L, Senior R M, Longmore W J and Moxley M A (1999). Recombinant SP-D carbohydrate recognition domain is a chemoattractant for human neutrophils. *Am J Physiol* **276** **1 Pt 1**: L131-136.
- Campagnari A A, Spinola S M, Lesse A J, Kwaik Y A, Mandrell R E and Apicella M A (1990). Lipooligosaccharide epitopes shared among gram-negative non-enteric mucosal pathogens. *Microb Pathog* **8** **5**: 353-362.
- Chailley-Heu B, Rubio S, Rougier J P, Ducroc R, Barlier-Mur A M, Ronco P and Bourbon J R (1997). Expression of hydrophilic surfactant proteins by mesentery cells in rat and man. *Biochem J* **328** **Pt 1**: 251-256.
- Chander A, Fisher A B and Strauss J F d (1982). Role of an acidic compartment in synthesis of disaturated phosphatidylcholine by rat granular pneumocytes. *Biochem J* **208** **3**: 651-658.
- Childs R A, Wright J R, Ross G F, Yuen C T, Lawson A M, Chai W, Drickamer K and Feizi T (1992). Specificity of lung surfactant protein SP-A for both the carbohydrate and the lipid moieties of certain neutral glycolipids. *J Biol Chem* **267** **14**: 9972-9979.

- Chronos Z C, Abdolrasulnia R, Whitsett J A, Rice W R and Shepherd V L (1996). Purification of a cell-surface receptor for surfactant protein A. *J Biol Chem* **271** **27**: 16375-16383.
- Clark J C, Wert S E, Bachurski C J, Stahlman M T, Stripp B R, Weaver T E and Whitsett J A (1995). Targeted disruption of the surfactant protein B gene disrupts surfactant homeostasis, causing respiratory failure in newborn mice. *Proc Natl Acad Sci U S A* **92** **17**: 7794-7798.
- Collins T, Williams A, Johnston G I, Kim J, Eddy R, Shows T, Gimbrone M A, Jr. and Bevilacqua M P (1991). Structure and chromosomal location of the gene for endothelial- leukocyte adhesion molecule 1. *J Biol Chem* **266** **4**: 2466-2473.
- Cornish A L, Freeman S, Forbes G, Ni J, Zhang M, Cepeda M, Gentz R, Augustus M, Carter K C and Crocker P R (1998). Characterization of siglec-5, a novel glycoprotein expressed on myeloid cells related to CD33. *Blood* **92** **6**: 2123-2132.
- Crocker P R, Clark E A, Filbin M, Gordon S, Jones Y, Kehrl J H, Kelm S, Le Douarin N, Powell L, Roder J, Schnaar R L, Sgroi D C, Stamenkovic K, Schauer R, Schachner M, van den Berg T K, van der Merwe P A, Watt S M and Varki A (1998). Siglecs: a family of sialic-acid binding lectins [letter]. *Glycobiology* **8** **2**: v.
- Crocker P R, Mucklow S, Bouckson V, McWilliam A, Willis A C, Gordon S, Milon G, Kelm S and Bradfield P (1994). Sialoadhesin, a macrophage sialic acid binding receptor for haemopoietic cells with 17 immunoglobulin-like domains. *Embo J* **13** **19**: 4490-4503.
- Crouch E, Parghi D, Kuan S F and Persson A (1992). Surfactant protein D: subcellular localization in nonciliated bronchiolar epithelial cells. *Am J Physiol* **263** **1 Pt 1**: L60-66.
- Crouch E, Persson A, Chang D and Heuser J (1994). Molecular structure of pulmonary surfactant protein D (SP-D). *J Biol Chem* **269** **25**: 17311-17319.
- Crouch E, Rust K, Marienchek W, Parghi D, Chang D and Persson A (1991). Developmental expression of pulmonary surfactant protein D (SP-D). *Am J Respir Cell Mol Biol* **5** **1**: 13-18.
- Crouch E, Rust K, Veile R, Donis-Keller H and Grosso L (1993). Genomic organization of human surfactant protein D (SP-D). SP-D is encoded on chromosome 10q22.2-23.1. *J Biol Chem* **268** **4**: 2976-2983.
- Dahms N M and Kornfeld S (1989). The cation-dependent mannose 6-phosphate receptor. Structural requirements for mannose 6-phosphate binding and oligomerization. *J Biol Chem* **264** **19**: 11458-11467.
- Danaher R J, Levin J C, Arking D, Burch C L, Sandlin R and Stein D C (1995). Genetic basis of *Neisseria gonorrhoeae* lipooligosaccharide antigenic variation. *J Bacteriol* **177** **24**: 7275-7279.

- Davis A E d and Lachmann P J (1984). Bovine conglutinin is a collagen-like protein. *Biochemistry* **23** **10**: 2139-2144.
- Day A J (1994). The C-type carbohydrate recognition domain (CRD) superfamily. *Biochem Soc Trans* **22** **1**: 83-88.
- Densen P, Gulati S and Rice P A (1987). Specificity of antibodies against *Neisseria gonorrhoeae* that stimulate neutrophil chemotaxis. Role of antibodies directed against lipooligosaccharides. *J Clin Invest* **80** **1**: 78-87.
- Densen P and Mandell G L (1978). Gonococcal interactions with polymorphonuclear neutrophils: importance of the phagosome for bactericidal activity. *J Clin Invest* **62** **6**: 1161-1171.
- DiScipio R G (1997). "Late components." , Berlin: Springer.
- Distel B, Bauer U, Le Borgne R and Hoflack B (1998). Basolateral sorting of the cation-dependent mannose 6-phosphate receptor in Madin-Darby canine kidney cells. Identification of a basolateral determinant unrelated to clathrin-coated pit localization signals. *J Biol Chem* **273** **1**: 186-193.
- Dolz R, Engel J and Kuhn K (1988). Folding of collagen IV. *Eur J Biochem* **178** **2**: 357-366.
- Drazek E S, Stein D C and Deal C D (1995). A mutation in the *Neisseria gonorrhoeae* rfaD homolog results in altered lipooligosaccharide expression. *J Bacteriol* **177** **9**: 2321-2327.
- Drickamer K (1988). Two distinct classes of carbohydrate-recognition domains in animal lectins. *J Biol Chem* **263** **20**: 9557-9560.
- Drickamer K (1992). Engineering galactose-binding activity into a C-type mannose-binding protein. *Nature* **360** **6400**: 183-186.
- Drickamer K (1995). Increasing diversity of animal lectin structures. *Curr Opin Struct Biol* **5** **5**: 612-616.
- Drickamer K (1997). Making a fitting choice: common aspects of sugar-binding sites in plant and animal lectins. *Structure* **5** **4**: 465-468.
- Drickamer K (1999). C-type lectin-like domains. *Curr Opin Struct Biol* **9** **5**: 585-590.
- Drickamer K, Dordal M S and Reynolds L (1986). Mannose-binding proteins isolated from rat liver contain carbohydrate-recognition domains linked to collagenous tails. Complete primary structures and homology with pulmonary surfactant apoprotein. *J Biol Chem* **261** **15**: 6878-6887.
- Drickamer K and Taylor M E (1993). Biology of animal lectins. *Annu Rev Cell Biol* **9** : 237-264.
- Drickamer K and Taylor M E (1998). Evolving views of protein glycosylation. *Trends Biochem Sci* **23** : 321-324.

- Dudas K C and Apicella M A (1988). Selection and immunochemical analysis of lipooligosaccharide mutants of *Neisseria gonorrhoeae*. *Infect Immun* **56** **2**: 499-504.
- Eggleton P, Ghebrehiwet B, Sastry K N, Coburn J P, Zaner K S, Reid K B and Tauber A I (1995). Identification of a gC1q-binding protein (gC1q-R) on the surface of human neutrophils. Subcellular localization and binding properties in comparison with the cC1q-R. *J Clin Invest* **95** **4**: 1569-1578.
- Elgavish S and Shaanan B (1997). Lectin-carbohydrate interactions: different folds, common recognition principles. *Trends Biochem Sci* **22** **12**: 462-467.
- Eliakim R, Goetz G S, Rubio S, Chailley-Heu B, Shao J S, Ducroc R and Alpers D H (1997). Isolation and characterization of surfactant-like particles in rat and human colon. *Am J Physiol* **272** **3 Pt 1**: G425-434.
- Farrell C F and Rest R F (1990). Up-regulation of human neutrophil receptors for *Neisseria gonorrhoeae* expressing PII outer membrane proteins. *Infect Immun* **58** **9**: 2777-2784.
- Feinberg H, Park-Snyder S, Kolatkar A R, Heise C T, Taylor M E and Weis W I (2000). Structure of a C-type carbohydrate-recognition domain from eth macrophage mannose receptor. *J Biol Chem* **In Press** : .
- Fiedler K, Parton R G, Kellner R, Etzold T and Simons K (1994). VIP36, a novel component of glycolipid rafts and exocytic carrier vesicles in epithelial cells. *Embo J* **13** **7**: 1729-1740.
- Fiedler K and Simons K (1994). A putative novel class of animal lectins in the secretory pathway homologous to leguminous lectins [letter]. *Cell* **77** **5**: 625-626.
- Fischer P B, Ellermann-Eriksen S, Thiel S, Jensenius J C and Mogensen S C (1994). Mannan-binding protein and bovine conglutinin mediate enhancement of herpes simplex virus type 2 infection in mice. *Scand J Immunol* **39** **5**: 439-445.
- Fisher A B, Dodia C, Chander A, Beers M F and Bates S R (1994). Inhibition of *Trimeresurus flavoviridis* phospholipase A2 by lung surfactant protein A (SP-A). *Biochim Biophys Acta* **1211** **3**: 256-262.
- Fisher J H and Mason R (1995). Expression of pulmonary surfactant protein D in rat gastric mucosa. *Am J Respir Cell Mol Biol* **12** **1**: 13-18.
- Floros J, Steinbrink R, Jacobs K, Phelps D, Kriz R, Recny M, Sultzman L, Jones S, Taeusch H W, Frank H A and et al. (1986). Isolation and characterization of cDNA clones for the 35-kDa pulmonary surfactant-associated protein. *J Biol Chem* **261** **19**: 9029-9033.
- Floyd-Smith G, Whitehead A S, Colten H R and Francke U (1986). The human C-reactive protein gene (CRP) and serum amyloid P component gene (APCS) are located on the proximal long arm of chromosome 1. *Immunogenetics* **24** **3**: 171-176.

- Foxall C, Watson S R, Dowbenko D, Fennie C, Lasky L A, Kiso M, Hasegawa A, Asa D and Brandley B K (1992). The three members of the selectin receptor family recognize a common carbohydrate epitope, the sialyl Lewis(x) oligosaccharide. *J Cell Biol* **117** 4: 895-902.
- Friis P, Svehag S E, Andersen O, Gahrn-Hansen B and Leslie R G (1991). Conglutinin exhibits a complement-dependent enhancement of the respiratory burst of phagocytes stimulated by *E. coli*. *Immunology* **74** 4: 680-684.
- Friis-Christiansen P, Thiel S, Svehag S E, Dessau R, Svendsen P, Andersen O, Laursen S B and Jensenius J C (1990). In vivo and in vitro antibacterial activity of conglutinin, a mammalian plasma lectin. *Scand J Immunol* **31** 4: 453-460.
- Gabel C A and Foster S A (1986). Mannose 6-phosphate receptor-mediated endocytosis of acid hydrolases: internalization of beta-glucuronidase is accompanied by a limited dephosphorylation. *J Cell Biol* **103** 5: 1817-1827.
- Gaitanaris G A, Vysokanov A, Hung S C, Gottesman M E and Gragerov A (1994). Successive action of *Escherichia coli* chaperones in vivo. *Mol Microbiol* **14** 5: 861-869.
- Gallagher D S, Jr., Ryan A M, Liou L S, Sastry K N and Womack J E (1993). Somatic cell mapping of conglutinin (CGN1) to cattle syntenic group U29 and fluorescence in situ localization to Chromosome 28. *Mamm Genome* **4** 12: 716-719.
- Gaynor C D, McCormack F X, Voelker D R, McGowan S E and Schlesinger L S (1995). Pulmonary surfactant protein A mediates enhanced phagocytosis of *Mycobacterium tuberculosis* by a direct interaction with human macrophages. *J Immunol* **155** 11: 5343-5351.
- Geijtenbeek T B, Kwon D S, Torensma R, van Vliet S J, van Duijnhoven G C, Middel J, Cornelissen I L, Nottet H S, KewalRamani V N, Littman D R, Figdor C G and van Kooyk Y (2000). DC-SIGN, a dendritic cell-specific HIV-1-binding protein that enhances trans-infection of T cells [see comments]. *Cell* **100** 5: 587-597.
- Geijtenbeek T B, Torensma R, van Vliet S J, van Duijnhoven G C, Adema G J, van Kooyk Y and Figdor C G (2000). Identification of DC-SIGN, a novel dendritic cell-specific ICAM-3 receptor that supports primary immune responses [see comments]. *Cell* **100** 5: 575-585.
- Gericke A, Flach C R and Mendelsohn R (1997). Structure and orientation of lung surfactant SP-C and L-alpha-dipalmitoylphosphatidylcholine in aqueous monolayers. *Biophys J* **73** 1: 492-499.
- Ghebrehiwet B, Bossone S, Erdei A and Reid K B (1988). Reversible biotinylation of C1q with a cleavable biotinyl derivative. Application in C1q receptor (C1qR) purification. *J Immunol Methods* **110** 2: 251-260.
- Giardina P C, Williams R, Lubaroff D and Apicella M A (1998). *Neisseria gonorrhoeae* induces focal polymerization of actin in primary human urethral epithelium. *Infect Immun* **66** 7: 3416-3419.

- Goodman A R, Cardozo T, Abagyan R, Altmeyer A, Wisniewski H G and Vilcek J (1996). Long pentraxins: an emerging group of proteins with diverse functions. *Cytokine Growth Factor Rev* **7 2**: 191-202.
- Gotschlich E C (1994). Genetic locus for the biosynthesis of the variable portion of *Neisseria gonorrhoeae* lipooligosaccharide. *J Exp Med* **180 6**: 2181-2190.
- Greene K E, Wright J R, Steinberg K P, Ruzinski J T, Caldwell E, Wong W B, Hull W, Whitsett J A, Akino T, Kuroki Y, Nagae H, Hudson L D and Martin T R (1999). Serial changes in surfactant-associated proteins in lung and serum before and after onset of ARDS [In Process Citation]. *Am J Respir Crit Care Med* **160 6**: 1843-1850.
- Greene K E, Ye S, Mason R J and Parsons P E (1999). Serum surfactant protein-A levels predict development of ARDS in at-risk patients. *Chest* **116 1 Suppl**: 90S-91S.
- Gregg C R, Johnson A P, Taylor-Robinson D, Melly M A and McGee Z A (1981). Host species-specific damage to oviduct mucosa by *Neisseria gonorrhoeae* lipopolysaccharide. *Infect Immun* **34 3**: 1056-1058.
- Gregg C R, Melly M A, Hellerqvist C G, Coniglio J G and McGee Z A (1981). Toxic activity of purified lipopolysaccharide of *Neisseria gonorrhoeae* for human fallopian tube mucosa. *J Infect Dis* **143 3**: 432-439.
- Griffiss J M, Jarvis G A, O'Brien J P, Eads M M and Schneider H (1991). Lysis of *Neisseria gonorrhoeae* initiated by binding of normal human IgM to a hexosamine-containing lipooligosaccharide epitope(s) is augmented by strain-specific, properdin-binding-dependent alternative complement pathway activation. *J Immunol* **147 1**: 298-305.
- Griffiss J M, O'Brien J P, Yamasaki R, Williams G D, Rice P A and Schneider H (1987). Physical heterogeneity of neisserial lipooligosaccharides reflects oligosaccharides that differ in apparent molecular weight, chemical composition, and antigenic expression. *Infect-Immun*. 1987 Aug; **55 8**: 1792-1800.
- Griffiss J M, Schneider H, Mandrell R E, Jarvis G A, Kim J J, Gibson B and Apicella M A (1987). The immunochemistry of neisserial LOS. *Antonie-Van-Leeuwenhoek*. 1987; **53 6**: 501-507.
- Griffiss J M, Schneider H, Mandrell R E, Yamasaki R, Jarvis G A, Kim J J, Gibson B W, Hamadeh R and Apicella M A (1988). Lipooligosaccharides: the principal glycolipids of the neisserial outer membrane. *Rev Infect Dis* **10 Suppl 2** : S287-295.
- Gross N J, Veldhuizen R, Possmayer F and Dhand R (1997). Surfactant convertase action is not essential for surfactant film formation. *Am J Physiol* **273 5 Pt 1**: L907-912.
- Gulati S, Guo N, Jensenius J C, Ezekowitz A B, Yamasaki R, Muhlecker W, Reinhold V N, Rice P A and Sastry K (1998). Mannan Binding Protein

- associated serine protease activates complement to kill serum resistant *Neisseria gonorrhoeae*. *International Complement Workshop*, : .
- Guymon L F, Esser M and Shafer W M (1982). Pyocin-resistant lipopolysaccharide mutants of *Neisseria gonorrhoeae*: alterations in sensitivity to normal human serum and polymyxin B. *Infect Immun* **36** **2**: 541-547.
- Haagsman H P, Hawgood S, Sargeant T, Buckley D, White R T, Drickamer K and Benson B J (1987). The major lung surfactant protein, SP 28-36, is a calcium-dependent, carbohydrate-binding protein. *J Biol Chem* **262** **29**: 13877-13880.
- Hakansson K, Lim N K, Hoppe H J and Reid K B (1999). Crystal structure of the trimeric alpha-helical coiled-coil and the three lectin domains of human lung surfactant protein D. *Structure Fold Des* **7** **3**: 255-264.
- Hakomori S (1981). Blood group ABH and Ii antigens of human erythrocytes: chemistry, polymorphism, and their developmental change. *Semin Hematol* **18** **1**: 39-62.
- Hallman M and Gluck L (1975). Phosphatidylglycerol in lung surfactant. II. Subcellular distribution and mechanism of biosynthesis in vitro. *Biochim Biophys Acta* **409** **2**: 172-191.
- Hamann J, Fiebig H and Strauss M (1993). Expression cloning of the early activation antigen CD69, a type II integral membrane protein with a C-type lectin domain. *J Immunol* **150** **11**: 4920-4927.
- Hammond C, Braakman I and Helenius A (1994). Role of N-linked oligosaccharide recognition, glucose trimming, and calnexin in glycoprotein folding and quality control. *Proc Natl Acad Sci U S A* **91** **3**: 913-917.
- Harlan W R, Jr., Margraf J H and Said S I (1966). Pulmonary lipid composition of species with and without surfactant. *Am J Physiol* **211** **3**: 855-861.
- Harrod K S, Trapnell B C, Otake K, Korfhagen T R and Whitsett J A (1999). SP-A enhances viral clearance and inhibits inflammation after pulmonary adenoviral infection. *Am J Physiol* **277** **3 Pt 1**: L580-588.
- Hartshorn K, Chang D, Rust K, White M, Heuser J and Crouch E (1996). Interactions of recombinant human pulmonary surfactant protein D and SP- D multimers with influenza A. *Am J Physiol* **271** **5 Pt 1**: L753-762.
- Hartshorn K L, Crouch E, White M R, Colamussi M L, Kakkanatt A, Tauber B, Shepherd V and Sastry K N (1998). Pulmonary surfactant proteins A and D enhance neutrophil uptake of bacteria. *Am J Physiol* **274** **6 Pt 1**: L958-969.
- Hartshorn K L, Crouch E C, White M R, Eggleton P, Tauber A I, Chang D and Sastry K (1994). Evidence for a protective role of pulmonary surfactant protein D (SP-D) against influenza A viruses. *J Clin Invest* **94** **1**: 311-319.
- Hartshorn K L, Sastry K, Brown D, White M R, Okarma T B, Lee Y M and Tauber A I (1993). Conglutinin acts as an opsonin for influenza A viruses. *J Immunol* **151** **11**: 6265-6273.

- Hartshorn K L, Sastry K N, Chang D, White M R and Crouch E C (2000). Enhanced anti-influenza activity of a surfactant protein D and serum collectin fusion protein. *Am J Physiol Lung Cell Mol Physiol* **278** 1: L90-98.
- Hartshorn K L, White M R, Ezekowitz R A, Sastry K and Crouch E (2000). Development of chimeric collectins with enhanced activity against influenza A virus [In Process Citation]. *Adv Exp Med Biol* **479** : 49-59.
- Hartshorn K L, White M R, Shepherd V, Reid K, Jensenius J C and Crouch E C (1997). Mechanisms of anti-influenza activity of surfactant proteins A and D: comparison with serum collectins. *Am J Physiol* **273** 6 Pt 1: L1156-1166.
- Hauck C R, Meyer T F, Lang F and Gulbins E (1998). CD66-mediated phagocytosis of Opa52 *Neisseria gonorrhoeae* requires a Src-like tyrosine kinase- and Rac1-dependent signalling pathway. *Embo J* **17** 2: 443-454.
- Haun R S, Serventi I M and Moss J (1992). Rapid, reliable ligation-independent cloning of PCR products using modified plasmid vectors. *Biotechniques* **13** 4: 515-518.
- Hawgood S, Benson B J and Hamilton R L, Jr. (1985). Effects of a surfactant-associated protein and calcium ions on the structure and surface activity of lung surfactant lipids. *Biochemistry* **24** 1: 184-190.
- Hawgood S, Benson B J, Schilling J, Damm D, Clements J A and White R T (1987). Nucleotide and amino acid sequences of pulmonary surfactant protein SP 18 and evidence for cooperation between SP 18 and SP 28-36 in surfactant lipid adsorption. *Proc Natl Acad Sci U S A* **84** 1: 66-70.
- Hawgood S and Clements J A (1990). Pulmonary surfactant and its apoproteins. *J Clin Invest* **86** 1: 1-6.
- Hawgood S, Derrick M and Poulain F (1998). Structure and properties of surfactant protein B. *Biochim Biophys Acta* **1408** 2-3: 150-160.
- Hawgood S, Efrati H, Schilling J and Benson B J (1985). Chemical characterization of lung surfactant apoproteins: amino acid composition, N-terminal sequence and enzymic digestion. *Biochem Soc Trans* **13** 6: 1092-1096.
- Hickman-Davis J, Gibbs-Erwin J, Lindsey J R and Matalon S (1999). Surfactant protein A mediates mycoplasmacidal activity of alveolar macrophages by production of peroxynitrite. *Proc Natl Acad Sci U S A* **96** 9: 4953-4958.
- Hirabayashi J and Kasai K (1993). The family of metazoan metal-independent beta-galactoside-binding lectins: structure, function and molecular evolution. *Glycobiology* **3** 4: 297-304.
- Hirani S, Lambris J D and Muller-Eberhard H J (1985). Localization of the conglutinin binding site on the third component of human complement. *J Immunol* **134** 2: 1105-1109.
- Hishikawa T, Cheung J Y, Yelamarty R V and Knutson D W (1991). Calcium transients during Fc receptor-mediated and nonspecific phagocytosis by murine peritoneal macrophages. *J Cell Biol* **115** 1: 59-66.

- Hitchcock P J (1989). Unified nomenclature for pathogenic *Neisseria* species. *Clin Microbiol Rev* **2 Suppl** : S64-65.
- Hofer E, Duchler M, Fuad S A, Houchins J P, Yabe T and Bach F H (1992). Candidate natural killer cell receptors. *Immunol Today* **13 11**: 429-430.
- Holmes B, Page A R and Good R A (1967). Studies of the metabolic activity of leukocytes from patients with a genetic abnormality of phagocytic function. *J Clin Invest* **46 9**: 1422-1432.
- Holmskov U and Jensenius J C (1993). Structure and function of collectins: humoral C-type lectins with collagenous regions. *Behring Inst Mitt* **93**: 224-235.
- Holmskov U, Laursen S B, Malhotra R, Wiedemann H, Timpl R, Stuart G R, Tornøe I, Madsen P S, Reid K B and Jensenius J C (1995). Comparative study of the structural and functional properties of a bovine plasma C-type lectin, collectin-43, with other collectins. *Biochem J* **305 Pt 3**: 889-896.
- Holmskov U, Lawson P, Teisner B, Tornøe I, Willis A C, Morgan C, Koch C and Reid K B (1997). Isolation and characterization of a new member of the scavenger receptor superfamily, glycoprotein-340 (gp-340), as a lung surfactant protein-D binding molecule. *J Biol Chem* **272 21**: 13743-13749.
- Holmskov U, Malhotra R, Sim R B and Jensenius J C (1994). Collectins: collagenous C-type lectins of the innate immune defense system. *Immunol Today* **15 2**: 67-74.
- Holmskov U, Mollenhauer J, Madsen J, Vitved L, Gronlund J, Tornøe I, Kliem A, Reid K B, Poustka A and Skjodt K (1999). Cloning of gp-340, a putative opsonin receptor for lung surfactant protein D. *Proc Natl Acad Sci U S A* **96 19**: 10794-10799.
- Holmskov U, Teisner B, Pedersen N T, Laursen S B, Rasmussen H B and Jensenius J C (1992). Tissue localization of conglutinin, a bovine C-type lectin. *Immunology* **76 1**: 169-173.
- Honda Y, Kuroki Y, Matsuura E, Nagae H, Takahashi H, Akino T and Abe S (1995). Pulmonary surfactant protein D in sera and bronchoalveolar lavage fluids. *Am J Respir Crit Care Med* **152 6 Pt 1**: 1860-1866.
- Hook E W d, Olsen D A and Buchanan T M (1984). Analysis of the antigen specificity of the human serum immunoglobulin G immune response to complicated gonococcal infection. *Infect Immun* **43 2**: 706-709.
- Hoppe H J, Barlow P N and Reid K B (1994). A parallel three stranded alpha-helical bundle at the nucleation site of collagen triple-helix formation. *FEBS Lett* **344 2-3**: 191-195.
- Hoppe H J and Reid K B (1994). Collectins--soluble proteins containing collagenous regions and lectin domains--and their roles in innate immunity. *Protein Sci* **3 8**: 1143-1158.

- Hoppe H J and Reid K B (1994). Trimeric C-type lectin domains in host defence. *Structure* **2** **12**: 1129-1133.
- Horisberger M, Vonlanthen M and Rosset J (1978). Localization of alpha-galactomannan and of wheat germ agglutinin receptors in *Schizosaccharomyces pombe*. *Arch Microbiol* **119** **2**: 107-111.
- Horowitz A D (1995). Exclusion of SP-C, but not SP-B, by gel phase palmitoyl lipids. *Chem Phys Lipids* **76** **1**: 27-39.
- Horowitz A D, Baatz J E and Whitsett J A (1993). Lipid effects on aggregation of pulmonary surfactant protein SP-C studied by fluorescence energy transfer. *Biochemistry* **32** **37**: 9513-9523.
- Hoyle G W and Hill R L (1988). Molecular cloning and sequencing of a cDNA for a carbohydrate binding receptor unique to rat Kupffer cells. *J Biol Chem* **263** **16**: 7487-7492.
- Ikegami M, Korfhagen T R, Bruno M D, Whitsett J A and Jobe A H (1997). Surfactant metabolism in surfactant protein A-deficient mice. *Am J Physiol* **272** **3 Pt 1**: L479-485.
- Ikegami M, Korfhagen T R, Whitsett J A, Bruno M D, Wert S E, Wada K and Jobe A H (1998). Characteristics of surfactant from SP-A-deficient mice. *Am J Physiol* **275** **2 Pt 1**: L247-254.
- Ingwer I, Petersen B H and Brooks G (1978). Serum bactericidal action and activation of the classic and alternate complement pathways by *Neisseria gonorrhoeae*. *J Lab Clin Med* **92** **2**: 211-220.
- Iobst S T and Drickamer K (1994). Binding of sugar ligands to Ca(2+)-dependent animal lectins. II. Generation of high-affinity galactose binding by site-directed mutagenesis. *J Biol Chem* **269** **22**: 15512-15519.
- Iobst S T, Wormald M R, Weis W I, Dwek R A and Drickamer K (1994). Binding of sugar ligands to Ca(2+)-dependent animal lectins. I. Analysis of mannose binding by site-directed mutagenesis and NMR. *J Biol Chem* **269** **22**: 15505-15511.
- Itin C, Roche A C, Monsigny M and Hauri H P (1996). ERGIC-53 is a functional mannose-selective and calcium-dependent human homologue of leguminous lectins. *Mol Biol Cell* **7** **3**: 483-493.
- Jacob G S, Welply J K, Scudder P R, Kirmaier C, Abbas S Z, Howard S C, Keene J L, Schmuke J J, Broschat K and Steininger C (1995). Studies on selectin-carbohydrate interactions. *Adv Exp Med Biol* **376** : 283-290.
- James J F and Swanson J (1978). Studies on gonococcus infection. XIII. Occurrence of color/opacity colonial variants in clinical cultures. *Infect Immun* **19** **1**: 332-340.
- Jennings H J, Johnson K G and Kenne L (1983). The structure of an R-type oligosaccharide core obtained from some lipopolysaccharides of *Neisseria meningitidis*. *Carbohydr Res* **121** : 233-241.

- Jensenius J C, Laursen S B, Zheng Y and Holmskov U (1994). Conglutinin and CL-43, two collagenous C-type lectins (collectins) in bovine serum. *Biochem Soc Trans* **22** **1**: 95-100.
- Jensenius J C, Thiel S, Baatrup G and Holmskov-Nielsen U (1985). Human conglutinin-like protein. *Biosci Rep* **5** **10-11**: 901-905.
- Jiang W, Swiggard W J, Heufler C, Peng M, Mirza A, Steinman R M and Nussenzweig M C (1995). The receptor DEC-205 expressed by dendritic cells and thymic epithelial cells is involved in antigen processing. *Nature* **375** **6527**: 151-155.
- Johansson J and Curstedt T (1997). Molecular structures and interactions of pulmonary surfactant components. *Eur J Biochem* **244** **3**: 675-693.
- Johansson J, Szyperski T, Curstedt T and Wuthrich K (1994). The NMR structure of the pulmonary surfactant-associated polypeptide SP-C in an apolar solvent contains a valyl-rich alpha-helix. *Biochemistry* **33** **19**: 6015-6023.
- John C M, Griffiss J M, Apicella M A, Mandrell R E and Gibson B W (1991). The structural basis for pyocin resistance in *Neisseria gonorrhoeae* lipooligosaccharides. *J Biol Chem* **266** **29**: 19303-19311.
- Johnston G I, Bliss G A, Newman P J and McEver R P (1990). Structure of the human gene encoding granule membrane protein-140, a member of the selectin family of adhesion receptors for leukocytes. *J Biol Chem* **265** **34**: 21381-21385.
- Johnston K H and Gotschlich E C (1974). Isolation and characterization of the outer membrane of *Neisseria gonorrhoeae*. *J Bacteriol* **119** **1**: 250-257.
- Johnston R B, Jr., Keele B B, Jr., Misra H P, Lehmyer J E, Webb L S, Baehner R L and RaJagopalan K V (1975). The role of superoxide anion generation in phagocytic bactericidal activity. Studies with normal and chronic granulomatous disease leukocytes. *J Clin Invest* **55** **6**: 1357-1372.
- Jordinson M, El-Hariry I, Calnan D, Calam J and Pignatelli M (1999). Vicia faba agglutinin, the lectin present in broad beans, stimulates differentiation of undifferentiated colon cancer cells [see comments]. *Gut* **44** **5**: 709-714.
- Judd R C (1989). Protein I: structure, function, and genetics. *Clin Microbiol Rev* **2** **Suppl** : S41-48.
- Kabha K, Schmegner J, Keisari Y, Parolis H, Schlepper-Schaeffer J and Ofek I (1997). SP-A enhances phagocytosis of *Klebsiella* by interaction with capsular polysaccharides and alveolar macrophages. *Am J Physiol* **272** **2 Pt 1**: L344-352.
- Kallstrom H, Islam M S, Berggren P O and Jonsson A B (1998). Cell signaling by the type IV pili of pathogenic *Neisseria*. *J Biol Chem* **273** **34**: 21777-21782.
- Kang J X, Li Y and Leaf A (1997). Mannose-6-phosphate/insulin-like growth factor-II receptor is a receptor for retinoic acid. *Proc Natl Acad Sci USA* **94** **25**: 13671-13676.

- Karlsson A, Follin P, Leffler H and Dahlgren C (1998). Galectin-3 activates the NADPH-oxidase in exudated but not peripheral blood neutrophils. *Blood* **91** **9**: 3430-3438.
- Kase T, Suzuki Y, Kawai T, Sakamoto T, Ohtani K, Eda S, Maeda A, Okuno Y, Kurimura T and Wakamiya N (1999). Human mannan-binding lectin inhibits the infection of influenza A virus without complement [In Process Citation]. *Immunology* **97** **3**: 385-392.
- Kawasaki N, Itoh N and Kawasaki T (1994). Gene organization and 5'-flanking region sequence of conglutinin: a C- type mammalian lectin containing a collagen-like domain. *Biochem Biophys Res Commun* **198** **2**: 597-604.
- Kawasaki N, Kawasaki T and Yamashina I (1983). Isolation and characterization of a mannan-binding protein from human serum. *J Biochem (Tokyo)* **94** **3**: 937-947.
- Kawasaki N, Kawasaki T and Yamashina I (1985). Mannan-binding protein and conglutinin in bovine serum. *J Biochem (Tokyo)* **98** **5**: 1309-1320.
- Kawasaki T, Etoh R and Yamashina I (1978). Isolation and characterization of a mannan-binding protein from rabbit liver. *Biochem Biophys Res Commun* **81** **3**: 1018-1024.
- Kelm S, Schauer R and Crocker P R (1996). The Sialoadhesins--a family of sialic acid-dependent cellular recognition molecules within the immunoglobulin superfamily. *Glycoconj J* **13** **6**: 913-926.
- Kelm S, Schauer R, Manuguerra J C, Gross H J and Crocker P R (1994). Modifications of cell surface sialic acids modulate cell adhesion mediated by sialoadhesin and CD22. *Glycoconj J* **11** **6**: 576-585.
- Khoor A, Gray M E, Hull W M, Whitsett J A and Stahlman M T (1993). Developmental expression of SP-A and SP-A mRNA in the proximal and distal respiratory epithelium in the human fetus and newborn. *J Histochem Cytochem* **41** **9**: 1311-1319.
- Kim J J, Zhou D, Mandrell R E and Griffiss J M (1992). Effect of exogenous sialylation of the lipooligosaccharide of *Neisseria gonorrhoeae* on opsonophagocytosis. *Infect Immun* **60** **10**: 4439-4442.
- King R J (1984). Lipid-apolipoprotein interactions in surfactant studied by reassembly. *Exp Lung Res* **6** **3-4**: 237-253.
- King R J and Clements J A (1972). Surface active materials from dog lung. 3. Thermal analysis. *Am J Physiol* **223** **3**: 727-733.
- King R J and Clements J A (1972). Surface active materials from dog lung. I. Method of isolation. *Am J Physiol* **223** **3**: 707-714.
- King R J and Clements J A (1972). Surface active materials from dog lung. II. Composition and physiological correlations. *Am J Physiol* **223** **3**: 715-726.

- King R J, Simon D and Horowitz P M (1989). Aspects of secondary and quaternary structure of surfactant protein A from canine lung. *Biochim Biophys Acta* **1001** **3**: 294-301.
- Kishore U, Wang J Y, Hoppe H J and Reid K B (1996). The alpha-helical neck region of human lung surfactant protein D is essential for the binding of the carbohydrate recognition domains to lipopolysaccharides and phospholipids. *Biochem J* **318 Pt 2**: 505-511.
- Klebanoff S J (1980). Oxygen metabolism and the toxic properties of phagocytes. *Ann Intern Med* **93** **3**: 480-489.
- Kolb-Bachofen V (1981). Hepatic receptor for asialo-glycoproteins. Ultrastructural demonstration of ligand-induced microaggregation of receptors. *Biochim Biophys Acta* **645** **2**: 293-299.
- Kolble K (1993). Regional mapping of short tandem repeats on human chromosome 10: cytochrome P450 gene CYP2E, D10S196, D10S220, and D10S225. *Genomics* **18** **3**: 702-704.
- Kolble K, Lu J, Mole S E, Kaluz S and Reid K B (1993). Assignment of the human pulmonary surfactant protein D gene (SFTP4) to 10q22-q23 close to the surfactant protein A gene cluster. *Genomics* **17** **2**: 294-298.
- Kolble K and Reid K B (1993). The genomics of soluble proteins with collagenous domains: C1q, MBL, SP- A, SP-D, conglutinin, and CL-43. *Behring Inst Mitt* **93**: 81-86.
- Korfhagen T R, Bruno M D, Glasser S W, Ciruolo P J, Whitsett J A, Lattier D L, Wikenheiser K A and Clark J C (1992). Murine pulmonary surfactant SP-A gene: cloning, sequence, and transcriptional activity. *Am J Physiol* **263** **5 Pt 1**: L546-554.
- Korfhagen T R, Bruno M D, Ross G F, Huelsman K M, Ikegami M, Jobe A H, Wert S E, Stripp B R, Morris R E, Glasser S W, Bachurski C J, Iwamoto H S and Whitsett J A (1996). Altered surfactant function and structure in SP-A gene targeted mice. *Proc Natl Acad Sci U S A* **93** **18**: 9594-9599.
- Kornfeld S (1992). Structure and function of the mannose 6-phosphate/insulinlike growth factor II receptors. *Annu Rev Biochem* **61** : 307-330.
- Kozutsumi Y, Kawasaki T and Yamashina I (1980). Isolation and characterization of a mannan-binding protein from rabbit serum. *Biochem Biophys Res Commun* **95** **2**: 658-664.
- Kreutzer D L, Dreyfus L A and Robertson D C (1979). Interaction of polymorphonuclear leukocytes with smooth and rough strains of *Brucella abortus*. *Infect Immun* **23** **3**: 737-742.
- Kuan S F, Persson A, Parghi D and Crouch E (1994). Lectin-mediated interactions of surfactant protein D with alveolar macrophages. *Am J Respir Cell Mol Biol* **10** **4**: 430-436.

- Kuan S F, Rust K and Crouch E (1992). Interactions of surfactant protein D with bacterial lipopolysaccharides. Surfactant protein D is an Escherichia coli-binding protein in bronchoalveolar lavage. *J Clin Invest* **90** 1: 97-106.
- Kubasova T, Petcu I, Pfuller U and Koteles G J (1999). Effects of mistletoe lectin I and ionizing radiation on the glucose and thymidine uptake in tumour cells in vitro. *Phytother Res* **13** 8: 655-659.
- Kuhlman M, Joiner K and Ezekowitz R A (1989). The human mannose-binding protein functions as an opsonin. *J Exp Med* **169** 5: 1733-1745.
- Kurata H, Cheng H M, Kozutsumi Y, Yokota Y and Kawasaki T (1993). Role of the collagen-like domain of the human serum mannan-binding protein in the activation of complement and the secretion of this lectin. *Biochem Biophys Res Commun* **191** 3: 1204-1210.
- Kuroki Y and Akino T (1991). Pulmonary surfactant protein A (SP-A) specifically binds dipalmitoylphosphatidylcholine. *J Biol Chem* **266** 5: 3068-3073.
- Kuroki Y, Gasa S, Ogasawara Y, Makita A and Akino T (1992). Binding of pulmonary surfactant protein A to galactosylceramide and asialo-GM2. *Arch Biochem Biophys* **299** 2: 261-267.
- Kuroki Y, Gasa S, Ogasawara Y, Shiratori M, Makita A and Akino T (1992). Binding specificity of lung surfactant protein SP-D for glucosylceramide. *Biochem Biophys Res Commun* **187** 2: 963-969.
- Kuroki Y, Mason R J and Voelker D R (1988). Chemical modification of surfactant protein A alters high affinity binding to rat alveolar type II cells and regulation of phospholipid secretion. *J Biol Chem* **263** 33: 17596-17602.
- Kuroki Y, McCormack F X, Ogasawara Y, Mason R J and Voelker D R (1994). Epitope mapping for monoclonal antibodies identifies functional domains of pulmonary surfactant protein A that interact with lipids. *J Biol Chem* **269** 47: 29793-29800.
- Kuroki Y, Shiratori M, Murata Y and Akino T (1991). Surfactant protein D (SP-D) counteracts the inhibitory effect of surfactant protein A (SP-A) on phospholipid secretion by alveolar type II cells. Interaction of native SP-D with SP-A. *Biochem J* **279** Pt 1: 115-119.
- Lachmann P J (1967). Conglutinin and immunoconglutinins. *Adv Immunol* **6** : 479-527.
- Lachmann P J and Muller-Eberhard H J (1968). The demonstration in human serum of "conglutinogen-activating factor" and its effect on the third component of complement. *J Immunol* **100** 4: 691-698.
- Laemmli U K (1970). Cleavage of structural proteins during the assembly of the head of bacteriophage T4. *Nature* **227** 259: 680-685.
- Lambden P R, Heckels J E, James L T and Watt P J (1979). Variations in surface protein composition associated with virulence properties in opacity types of *Neisseria gonorrhoeae*. *J Gen Microbiol* **114** 2: 305-312.

- Lambden P R, Robertson J N and Watt P J (1981). The preparation and properties of alpha and beta pili from variants of *Neisseria gonorrhoeae* P9. *J Gen Microbiol* **124 Pt 1**: 109-117.
- Lammel C J, Sweet R L, Rice P A, Knapp J S, Schoolnik G K, Heilbron D C and Brooks G F (1985). Antibody-antigen specificity in the immune response to infection with *Neisseria gonorrhoeae*. *J Infect Dis* **152 5**: 990-1001.
- Larigan J D, Tsang T C, Rumberger J M and Burns D K (1992). Characterization of cDNA and genomic sequences encoding rabbit ELAM-1: conservation of structure and functional interactions with leukocytes. *DNA Cell Biol* **11 2**: 149-162.
- Lasky L A (1991). Lectin cell adhesion molecules (LEC-CAMs): a new family of cell adhesion proteins involved with inflammation. *J Cell Biochem* **45 2**: 139-146.
- Lasky L A (1992). Selectins: interpreters of cell-specific carbohydrate information during inflammation. *Science* **258 5084**: 964-969.
- Laursen S B, Thiel S, Teisner B, Holmskov U, Wang Y, Sim R B and Jensenius J C (1994). Bovine conglutinin binds to an oligosaccharide determinant presented by iC3b, but not by C3, C3b or C3c. *Immunology* **81 4**: 648-654.
- Le Y, Lee S H, Kon O L and Lu J (1998). Human L-ficolin: plasma levels, sugar specificity, and assignment of its lectin activity to the fibrinogen-like (FBG) domain. *FEBS Lett* **425 2**: 367-370.
- Lee R T, Ichikawa Y, Fay M, Drickamer K, Shao M C and Lee Y C (1991). Ligand-binding characteristics of rat serum-type mannan-binding protein (MBP-A). Homology of binding site architecture with mammalian and chicken hepatic lectins. *J Biol Chem* **266 8**: 4810-4815.
- Lee R T, Ichikawa Y, Kawasaki T, Drickamer K and Lee Y C (1992). Multivalent ligand binding by serum mannan-binding protein. *Arch Biochem Biophys* **299 1**: 129-136.
- Lee Y M, Leiby K R, Allar J, Paris K, Lerch B and Okarma T B (1991). Primary structure of bovine conglutinin, a member of the C-type animal lectin family. *J Biol Chem* **266 5**: 2715-2723.
- Leon M A and Yokohari R (1964). Conglutinin: specific inhibition by carbohydrates. *Science* **143** : 1327-1328.
- LeVine A M, Bruno M D, Huelsman K M, Ross G F, Whitsett J A and Korfhagen T R (1997). Surfactant protein A-deficient mice are susceptible to group B streptococcal infection. *J Immunol* **158 9**: 4336-4340.
- LeVine A M, Gwozdz J, Stark J, Bruno M, Whitsett J and Korfhagen T (1999). Surfactant protein-A enhances respiratory syncytial virus clearance in vivo. *J Clin Invest* **103 7**: 1015-1021.

- LeVine A M, Kurak K E, Bruno M D, Stark J M, Whitsett J A and Korfhagen T R (1998). Surfactant protein-A-deficient mice are susceptible to *Pseudomonas aeruginosa* infection. *Am J Respir Cell Mol Biol* **19** 4: 700-708.
- Lim B L, Lu J and Reid K B (1993). Structural similarity between bovine conglutinin and bovine lung surfactant protein D and demonstration of liver as a site of synthesis of conglutinin. *Immunology* **78** 1: 159-165.
- Lim B L, Wang J Y, Holmskov U, Hoppe H J and Reid K B (1994). Expression of the carbohydrate recognition domain of lung surfactant protein D and demonstration of its binding to lipopolysaccharides of gram-negative bacteria. *Biochem Biophys Res Commun* **202** 3: 1674-1680.
- Lim B L, Willis A C, Reid K B, Lu J, Laursen S B, Jensenius J C and Holmskov U (1994). Primary structure of bovine collectin-43 (CL-43). Comparison with conglutinin and lung surfactant protein-D. *J Biol Chem* **269** 16: 11820-11824.
- Limper A H, O'Riordan D M, Vuk-Pavlovic Z and Crouch E C (1994). Accumulation of surfactant protein D in the lung during *Pneumocystis carinii* pneumonia. *J Eukaryot Microbiol* **41** 5: 98S.
- Lin L, Ayala P, Larson J, Mulks M, Fukuda M, Carlsson S R, Enns C and So M (1997). The *Neisseria* type 2 IgA1 protease cleaves LAMP1 and promotes survival of bacteria within epithelial cells. *Mol Microbiol* **24** 5: 1083-1094.
- Linscott W D, Ranken R and Triglia R P (1978). Evidence that bovine conglutinin reacts with an early product of C3b degradation, and an improved conglutination assay. *J Immunol* **121** 2: 658-664.
- Liou L S, Sastry R, Hartshorn K L, Lee Y M, Okarma T B, Tauber A I and Sastry K N (1994). Bovine conglutinin (BC) mRNA expressed in liver: cloning and characterization of the BC cDNA reveals strong homology to surfactant protein-D. *Gene* **141** 2: 277-281.
- Liou L S, Sastry R, Hartshorn K L, Lee Y M, Okarma T B, Tauber A I and Sastry K N (1994). Bovine conglutinin gene exon structure reveals its evolutionary relationship to surfactant protein-D. *J Immunol* **153** 1: 173-180.
- Loveless R W, Holmskov U and Feizi T (1995). Collectin-43 is a serum lectin with a distinct pattern of carbohydrate recognition. *Immunology* **85** 4: 651-659.
- Lu J, Laursen S B, Thiel S, Jensenius J C and Reid K B (1993). The cDNA cloning of conglutinin and identification of liver as a primary site of synthesis of conglutinin in members of the Bovidae. *Biochem J* **292** Pt 1: 157-162.
- Lu J and Le Y (1998). Ficolins and the fibrinogen-like domain. *Immunobiology* **199** 2: 190-199.
- Lu J, Tay P N, Kon O L and Reid K B (1996). Human ficolin: cDNA cloning, demonstration of peripheral blood leucocytes as the major site of synthesis and assignment of the gene to chromosome 9. *Biochem J* **313** Pt 2: 473-478.
- Lu J, Wiedemann H, Holmskov U, Thiel S, Timpl R and Reid K B (1993). Structural similarity between lung surfactant protein D and conglutinin. Two

- distinct, C-type lectins containing collagen-like sequences. *Eur J Biochem* **215** 3: 793-799.
- Lu J, Willis A C and Reid K B (1992). Purification, characterization and cDNA cloning of human lung surfactant protein D. *Biochem J* **284 Pt 3**: 795-802.
- Luchetti M M, Piccinini G, Mantovani A, Peri G, Matteucci C, Pomponio G, Fratini M, Fraticelli P, Sambo P, Di Loreto C, Doni A, Introna M and Gabrielli A (2000). Expression and production of the long pentraxin PTX3 in rheumatoid arthritis (RA). *Clin Exp Immunol* **119 1**: 196-202.
- Luderitz O, Galanos C, Lehmann V, Nurminen M, Rietschel E T, Rosenfelder G, Simon M and Westphal O (1973). Lipid A: chemical structure and biological activity. *J Infect Dis* **128** : Suppl:17-29.
- Luderitz O and Westphal O (1966). The significance of enterobacterial mutants for the chemical investigation of their cell-wall polysaccharides. *Angew Chem Int Ed Engl* **5 2**: 198-210.
- Luo W, Van de Velde H, von Hoegen I, Parnes J R and Thielemans K (1992). Ly-1 (CD5), a membrane glycoprotein of mouse T lymphocytes and a subset of B cells, is a natural ligand of the B cell surface protein Lyb-2 (CD72). *J Immunol* **148 6**: 1630-1634.
- Macher B A and Sweeley C C (1978). Glycosphingolipids: structure, biological source, and properties. *Methods Enzymol* **50** : 236-251.
- Madan T, Eggleton P, Kishore U, Strong P, Aggrawal S S, Sarma P U and Reid K B (1997). Binding of pulmonary surfactant proteins A and D to *Aspergillus fumigatus* conidia enhances phagocytosis and killing by human neutrophils and alveolar macrophages. *Infect Immun* **65 8**: 3171-3179.
- Madan T, Kishore U, Shah A, Eggleton P, Strong P, Wang J Y, Aggrawal S S, Sarma P U and Reid K B (1997). Lung surfactant proteins A and D can inhibit specific IgE binding to the allergens of *Aspergillus fumigatus* and block allergen-induced histamine release from human basophils. *Clin Exp Immunol* **110 2**: 241-249.
- Malhotra R (1993). Collectin receptor (C1q receptor): structure and function. *Behring Inst Mitt* **93**: 254-261.
- Malhotra R, Haurum J, Thiel S and Sim R B (1992). Interaction of C1q receptor with lung surfactant protein A. *Eur J Immunol* **22 6**: 1437-1445.
- Malhotra R, Lu J, Holmskov U and Sim R B (1994). Collectins, collectin receptors and the lectin pathway of complement activation. *Clin Exp Immunol* **97 Suppl 2** : 4-9.
- Malhotra R, Willis A C, Jensenius J C, Jackson J and Sim R B (1993). Structure and homology of human C1q receptor (collectin receptor). *Immunology* **78 3**: 341-348.

- Malmqvist M and Karlsson R (1997). Biomolecular interaction analysis: affinity biosensor technologies for functional analysis of proteins. *Curr Opin Chem Biol* **1** **3**: 378-383.
- Malorny B, Morelli G, Kusecek B, Kolberg J and Achtman M (1998). Sequence diversity, predicted two-dimensional protein structure, and epitope mapping of neisserial Opa proteins. *J Bacteriol* **180** **5**: 1323-1330.
- Mandrell R, Schneider H, Apicella M, Zollinger W, Rice P A and Griffiss J M (1986). Antigenic and physical diversity of *Neisseria gonorrhoeae* lipooligosaccharides. *Infect Immun* **54** **1**: 63-69.
- Mandrell R E and Apicella M A (1993). Lipo-oligosaccharides (LOS) of mucosal pathogens: molecular mimicry and host-modification of LOS. *Immunobiology* **187** **3-5**: 382-402.
- Mandrell R E, Griffiss J M and Macher B A (1988). Lipooligosaccharides (LOS) of *Neisseria gonorrhoeae* and *Neisseria meningitidis* have components that are immunochemically similar to precursors of human blood group antigens. Carbohydrate sequence specificity of the mouse monoclonal antibodies that recognize crossreacting antigens on LOS and human erythrocytes [published erratum appears in *J Exp Med* 1988 Oct 1;168(4):1517]. *J Exp Med* **168** **1**: 107-126.
- Mandrell R E, Lesse A J, Sugai J V, Shero M, Griffiss J M, Cole J A, Parsons N J, Smith H, Morse S A and Apicella M A (1990). In vitro and in vivo modification of *Neisseria gonorrhoeae* lipooligosaccharide epitope structure by sialylation. *J-Exp-Med*. 1990 May 1; **171** **5**: 1649-1664.
- Manz-Keinke H, Egenhofer C, Plattner H and Schlepper-Schafer J (1991). Specific interaction of lung surfactant protein A (SP-A) with rat alveolar macrophages. *Exp Cell Res* **192** **2**: 597-603.
- Manz-Keinke H, Plattner H and Schlepper-Schafer J (1992). Lung surfactant protein A (SP-A) enhances serum-independent phagocytosis of bacteria by alveolar macrophages. *Eur J Cell Biol* **57** **1**: 95-100.
- Marceau M, Beretti J L and Nassif X (1995). High adhesiveness of encapsulated *Neisseria meningitidis* to epithelial cells is associated with the formation of bundles of pili. *Mol Microbiol* **17** **5**: 855-863.
- Marceau M and Nassif X (1999). Role of glycosylation at Ser63 in production of soluble pilin in pathogenic *Neisseria*. *J Bacteriol* **181** **2**: 656-661.
- Margolis R U and Margolis R K (1994). Aggrecan-versican-neurocan family proteoglycans. *Methods Enzymol* **245** : 105-126.
- Matsushita M, Endo Y and Fujita T (2000). Cutting edge: complement-activating complex of ficolin and mannose-binding lectin-associated serine protease [In Process Citation]. *J Immunol* **164** **5**: 2281-2284.

- Matsushita M and Fujita T (1992). Activation of the classical complement pathway by mannose-binding protein in association with a novel C1s-like serine protease. *J Exp Med* **176** **6**: 1497-1502.
- McCormack F X, Damodarasamy M and Elhalwagi B M (1999). Deletion mapping of N-terminal domains of surfactant protein A. The N-terminal segment is required for phospholipid aggregation and specific inhibition of surfactant secretion. *J Biol Chem* **274** **5**: 3173-3181.
- McCormack F X, Festa A L, Andrews R P, Linke M and Walzer P D (1997). The carbohydrate recognition domain of surfactant protein A mediates binding to the major surface glycoprotein of *Pneumocystis carinii*. *Biochemistry* **36** **26**: 8092-8099.
- McCormack F X, Pattanajitvilai S, Stewart J, Possmayer F, Inchley K and Voelker D R (1997). The Cys6 intermolecular disulfide bond and the collagen-like region of rat SP-A play critical roles in interactions with alveolar type II cells and surfactant lipids. *J Biol Chem* **272** **44**: 27971-27979.
- McDade R L, Jr. and Johnston K H (1980). Characterization of serologically dominant outer membrane proteins of *Neisseria gonorrhoeae*. *J Bacteriol* **141** **3**: 1183-1191.
- McIntosh J C, Swyers A H, Fisher J H and Wright J R (1996). Surfactant proteins A and D increase in response to intratracheal lipopolysaccharide. *Am J Respir Cell Mol Biol* **15** **4**: 509-519.
- McNeely T B and Coonrod J D (1994). Aggregation and opsonization of type A but not type B Hemophilus influenzae by surfactant protein A. *Am J Respir Cell Mol Biol* **11** **1**: 114-122.
- Michelis D, Kounnas M Z, Argraves W S, Sanford E D, Borchelt J D and Wright J R (1994). Interaction of surfactant protein A with cellular myosin. *Am J Respir Cell Mol Biol* **11** **6**: 692-700.
- Micklem K J, Sim R B and Sim E (1984). Analysis of C3-receptor activity on human B-lymphocytes and isolation of the complement receptor type 2 (CR2). *Biochem J* **224** **1**: 75-86.
- Mishkind M, Raikhel N V, Palevitz B A and Keegstra K (1982). Immunocytochemical localization of wheat germ agglutinin in wheat. *J Cell Biol* **92** **3**: 753-764.
- Mizuochi T, Loveless R W, Lawson A M, Chai W, Lachmann P J, Childs R A, Thiel S and Feizi T (1989). A library of oligosaccharide probes (neoglycolipids) from N-glycosylated proteins reveals that conglutinin binds to certain complex-type as well as high mannose-type oligosaccharide chains. *J Biol Chem* **264** **23**: 13834-13839.
- Morse S A, Jones B V and Lysko P G (1980). Pyocin inhibition of *Neisseria gonorrhoeae*: mechanism of action. *Antimicrob Agents Chemother* **18** **3**: 416-423.

- Motwani M, White R A, Guo N, Dowler L L, Tauber A I and Sastry K N (1995). Mouse surfactant protein-D. cDNA cloning, characterization, and gene localization to chromosome 14. *J Immunol* **155** **12**: 5671-5677.
- Mullin N P, Hall K T and Taylor M E (1994). Characterization of ligand binding to a carbohydrate-recognition domain of the macrophage mannose receptor. *J Biol Chem* **269** **45**: 28405-28413.
- Nairn C A, Cole J A, Patel P V, Parsons N J, Fox J E and Smith H (1988). Cytidine 5'-monophospho-N-acetylneuraminic acid or a related compound is the low Mr factor from human red blood cells which induces gonococcal resistance to killing by human serum. *J Gen Microbiol* **134** **Pt 12**: 3295-3306.
- Nepomuceno R R, Henschen-Edman A H, Burgess W H and Tenner A J (1997). cDNA cloning and primary structure analysis of C1qR(P), the human C1q/MBL/SPA receptor that mediates enhanced phagocytosis in vitro. *Immunity* **6** **2**: 119-129.
- Nielsen B B, Kastrup J S, Rasmussen H, Holtet T L, Graversen J H, Etzerodt M, Thogersen H C and Larsen I K (1997). Crystal structure of tetranectin, a trimeric plasminogen-binding protein with an alpha-helical coiled coil. *FEBS Lett* **412** **2**: 388-396.
- Nikaido H and Nakae T (1979). The outer membrane of Gram-negative bacteria. *Adv Microb Physiol* **20** : 163-250.
- Nilsson B and Nilsson Ekdahl K (1997). "Components of alternative pathway." , Berlin: Springer.
- O'Reilly M A, Weaver T E, Pilot-Matias T J, Sarin V K, Gazdar A F and Whitsett J A (1989). In vitro translation, post-translational processing and secretion of pulmonary surfactant protein B precursors. *Biochim Biophys Acta* **1011** **2-3**: 140-148.
- O'Riordan D M, Standing J E, Kwon K Y, Chang D, Crouch E C and Limper A H (1995). Surfactant protein D interacts with *Pneumocystis carinii* and mediates organism adherence to alveolar macrophages. *J Clin Invest* **95** **6**: 2699-2710.
- Oda Y, Herrmann J, Gitt M A, Turck C W, Burlingame A L, Barondes S H and Leffler H (1993). Soluble lactose-binding lectin from rat intestine with two different carbohydrate-binding domains in the same peptide chain. *J Biol Chem* **268** **8**: 5929-5939.
- Odeberg and Olsson I (1976). Microbicidal mechanisms of human granulocytes: synergistic effects of granulocyte elastase and myeloperoxidase or chymotrypsin-like cationic protein. *Infect Immun* **14** **6**: 1276-1283.
- Odeberg H and Olsson I (1976). Mechanisms for the microbicidal activity of cationic proteins of human granulocytes. *Infect Immun* **14** **6**: 1269-1275.
- Ogasawara Y, McCormack F X, Mason R J and Voelker D R (1994). Chimeras of surfactant proteins A and D identify the carbohydrate recognition domains as essential for phospholipid interaction. *J Biol Chem* **269** **47**: 29785-29792.

- Ohashi T and Erickson H P (1997). Two oligomeric forms of plasma ficolin have differential lectin activity. *J Biol Chem* **272** **22**: 14220-14226.
- Ohmer-Schrock D, Schlatterer C, Plattner H and Schlepper-Schafer J (1993). Interaction of lung surfactant protein A with alveolar macrophages. *Microsc Res Tech* **26** **5**: 374-380.
- Ohtani K, Suzuki Y, Eda S, Kawai T, Kase T, Yamazaki H, Shimada T, Keshi H, Sakai Y, Fukuoh A, Sakamoto T and Wakamiya N (1999). Molecular cloning of a novel human collectin from liver (CL-L1). *J Biol Chem* **274** **19**: 13681-13689.
- Oka S, Ikeda K, Kawasaki T and Yamashina I (1988). Isolation and characterization of two distinct mannan-binding proteins from rat serum. *Arch Biochem Biophys* **260** **1**: 257-266.
- Oosterlaken-Dijksterhuis M A, van Eijk M, van Buel B L, van Golde L M and Haagsman H P (1991). Surfactant protein composition of lamellar bodies isolated from rat lung. *Biochem J* **274** **Pt 1**: 115-119.
- Oosterlaken-Dijksterhuis M A, van Eijk M, van Golde L M and Haagsman H P (1992). Lipid mixing is mediated by the hydrophobic surfactant protein SP-B but not by SP-C. *Biochim Biophys Acta* **1110** **1**: 45-50.
- Osmand A P, Friedenson B, Gewurz H, Painter R H, Hofmann T and Shelton E (1977). Characterization of C-reactive protein and the complement subcomponent C1t as homologous proteins displaying cyclic pentameric symmetry (pentraxins). *Proc Natl Acad Sci U S A* **74** **2**: 739-743.
- Palaniyar N, Ridsdale R A, Hearn S A, Heng Y M, Ottensmeyer F P, Possmayer F and Harauz G (1999). Filaments of surfactant protein A specifically interact with corrugated surfaces of phospholipid membranes. *Am J Physiol* **276** **4 Pt 1**: L631-641.
- Palaniyar N, Ridsdale R A, Hearn S A, Possmayer F and Harauz G (1999). Formation of membrane lattice structures and their specific interactions with surfactant protein A. *Am J Physiol* **276** **4 Pt 1**: L642-649.
- Pangburn M K (1997). "Alternative pathway: activation and regulation." , Berlin: Springer.
- Parge H E, Forest K T, Hickey M J, Christensen D A, Getzoff E D and Tainer J A (1995). Structure of the fibre-forming protein pilin at 2.6 Å resolution. *Nature* **378** **6552**: 32-38.
- Parsons N J, Andrade J R, Patel P V, Cole J A and Smith H (1989). Sialylation of lipopolysaccharide and loss of absorption of bactericidal antibody during conversion of gonococci to serum resistance by cytidine 5'-monophospho-N-acetyl neuraminic acid. *Microb Pathog* **7** **1**: 63-72.
- Parsons N J, Patel P V, Tan E L, Andrade J R, Nairn C A, Goldner M, Cole J A and Smith H (1988). Cytidine 5'-monophospho-N-acetyl neuraminic acid and a low molecular weight factor from human blood cells induce lipopolysaccharide

- alteration in gonococci when conferring resistance to killing by human serum. *Microb Pathog* **5** **4**: 303-309.
- Peppler M S (1984). Two physically and serologically distinct lipopolysaccharide profiles in strains of *Bordetella pertussis* and their phenotype variants. *Infect Immun* **43** **1**: 224-232.
- Pepys M B and Baltz M L (1983). Acute phase proteins with special reference to C-reactive protein and related proteins (pentaxins) and serum amyloid A protein. *Adv Immunol* **34** : 141-212.
- Pepys M B and Butler P J (1987). Serum amyloid P component is the major calcium-dependent specific DNA binding protein of the serum. *Biochem Biophys Res Commun* **148** **1**: 308-313.
- Perez-Gil J, Casals C and Marsh D (1995). Interactions of hydrophobic lung surfactant proteins SP-B and SP-C with dipalmitoylphosphatidylcholine and dipalmitoylphosphatidylglycerol bilayers studied by electron spin resonance spectroscopy. *Biochemistry* **34** **12**: 3964-3971.
- Persson A, Chang D and Crouch E (1990). Surfactant protein D is a divalent cation-dependent carbohydrate-binding protein. *J Biol Chem* **265** **10**: 5755-5760.
- Persson A, Chang D, Rust K, Moxley M, Longmore W and Crouch E (1989). Purification and biochemical characterization of CP4 (SP-D), a collagenous surfactant-associated protein. *Biochemistry* **28** **15**: 6361-6367.
- Persson A, Rust K, Chang D, Moxley M, Longmore W and Crouch E (1988). CP4: a pneumocyte-derived collagenous surfactant-associated protein. Evidence for heterogeneity of collagenous surfactant proteins. *Biochemistry* **27** **23**: 8576-8584.
- Peumans W J and van Damme E J (1995). The role of lectins in plant defence. *Histochem J* **27** **4**: 253-271.
- Phelps D S and Floros J (1988). Localization of surfactant protein synthesis in human lung by in situ hybridization. *Am Rev Respir Dis* **137** **4**: 939-942.
- Pilatte Y, Bignon J and Lambre C R (1993). Sialic acids as important molecules in the regulation of the immune system: pathophysiological implications of sialidases in immunity. *Glycobiology* **3** **3**: 201-218.
- Pison U, Max M, Neuendank A, Weissbach S and Pietschmann S (1994). Host defence capacities of pulmonary surfactant: evidence for 'non-surfactant' functions of the surfactant system. *Eur J Clin Invest* **24** **9**: 586-599.
- Pison U, Wright J R and Hawgood S (1992). Specific binding of surfactant apoprotein SP-A to rat alveolar macrophages. *Am J Physiol* **262** **4 Pt 1**: L412-417.
- Porat N, Apicella M A and Blake M S (1995). A lipooligosaccharide-binding site on HepG2 cells similar to the gonococcal opacity-associated surface protein Opa. *Infect Immun* **63** **6**: 2164-2172.

- Porat N, Apicella M A and Blake M S (1995). Neisseria gonorrhoeae utilizes and enhances the biosynthesis of the asialoglycoprotein receptor expressed on the surface of the hepatic HepG2 cell line. *Infect Immun* **63** **4**: 1498-1506.
- Possmayer F (1988). A proposed nomenclature for pulmonary surfactant-associated proteins. *Am Rev Respir Dis* **138** **4**: 990-998.
- Poulain F R, Allen L, Williams M C, Hamilton R L and Hawgood S (1992). Effects of surfactant apolipoproteins on liposome structure: implications for tubular myelin formation. *Am J Physiol* **262** **6 Pt 1**: L730-739.
- Powell L D and Varki A (1994). The oligosaccharide binding specificities of CD22 beta, a sialic acid- specific lectin of B cells. *J Biol Chem* **269** **14**: 10628-10636.
- Powell L D and Varki A (1995). I-type lectins. *J Biol Chem* **270** **24**: 14243-14246.
- Preston A, Mandrell R E, Gibson B W and Apicella M A (1996). The lipooligosaccharides of pathogenic gram-negative bacteria. *Crit Rev Microbiol* **22** **3**: 139-180.
- Qanbar R, Cheng S, Possmayer F and Schurch S (1996). Role of the palmitoylation of surfactant-associated protein C in surfactant film formation and stability. *Am J Physiol* **271** **4 Pt 1**: L572-580.
- Quie P G, White J G, Holmes B and Good R A (1967). In vitro bactericidal capacity of human polymorphonuclear leukocytes: diminished activity in chronic granulomatous disease of childhood. *J Clin Invest* **46** **4**: 668-679.
- Ram S, McQuillen D P, Gulati S, Elkins C, Pangburn M K and Rice P A (1998). Binding of complement factor H to loop 5 of porin protein 1A: a molecular mechanism of serum resistance of nonsialylated Neisseria gonorrhoeae. *J Exp Med* **188** **4**: 671-680.
- Ram S, Sharma A K, Simpson S D, Gulati S, McQuillen D P, Pangburn M K and Rice P A (1998). A novel sialic acid binding site on factor H mediates serum resistance of sialylated Neisseria gonorrhoeae. *J Exp Med* **187** **5**: 743-752.
- Reading P C, Holmskov U and Anders E M (1998). Antiviral activity of bovine collectins against rotaviruses. *J Gen Virol* **79 Pt 9**: 2255-2263.
- Reid K B (1993). Structure/function relationships in the collectins (mammalian lectins containing collagen-like regions). *Biochem Soc Trans* **21** **2**: 464-468.
- Reid K B and Turner M W (1994). Mammalian lectins in activation and clearance mechanisms involving the complement system. *Springer Semin Immunopathol* **15** **4**: 307-326.
- Reid K B M (1997). "Classical Pathway of activation." , Berlin: Springer.
- Reid K B M (1997). "Lectin- Pathway of non-self recognition." , Berlin: Springer.
- Rest R F, Fischer S H, Ingham Z Z and Jones J F (1982). Interactions of Neisseria gonorrhoeae with human neutrophils: effects of serum and gonococcal opacity on phagocyte killing and chemiluminescence. *Infect Immun* **36** **2**: 737-744.

- Reynolds H Y (1991). Immunologic system in the respiratory tract. *Physiol Rev* **71** 4: 1117-1133.
- Rice K G and Lee Y C (1990). Modification of triantennary glycopeptide into probes for the asialoglycoprotein receptor of hepatocytes. *J Biol Chem* **265** 30: 18423-18428.
- Rice K G, Weisz O A, Barthel T, Lee R T and Lee Y C (1990). Defined geometry of binding between triantennary glycopeptide and the asialoglycoprotein receptor of rat hepatocytes. *J Biol Chem* **265** 30: 18429-18434.
- Rice P A, Blake M S and Joiner K A (1987). Mechanisms of stable serum resistance of *Neisseria gonorrhoeae*. *Antonie Van Leeuwenhoek* **53** 6: 565-574.
- Rice P A and Kasper D L (1977). Characterization of gonococcal antigens responsible for induction of bactericidal antibody in disseminated infection. *J Clin Invest* **60** 5: 1149-1158.
- Rice P A, McCormack W M and Kasper D L (1980). Natural serum bactericidal activity against *Neisseria gonorrhoeae* isolates from disseminated, locally invasive, and uncomplicated disease. *J Immunol* **124** 5: 2105-2109.
- Rice P A, Vayo H E, Tam M R and Blake M S (1986). Immunoglobulin G antibodies directed against protein III block killing of serum-resistant *Neisseria gonorrhoeae* by immune serum. *J Exp Med* **164** 5: 1735-1748.
- Roberts D L, Weix D J, Dahms N M and Kim J J (1998). Molecular basis of lysosomal enzyme recognition: three-dimensional structure of the cation-dependent mannose 6-phosphate receptor. *Cell* **93** 4: 639-648.
- Ross G F, Notter R H, Meuth J and Whitsett J A (1986). Phospholipid binding and biophysical activity of pulmonary surfactant-associated protein (SAP)-35 and its non-collagenous COOH-terminal domains. *J Biol Chem* **261** 30: 14283-14291.
- Rosseau S, Guenther A, Seeger W and Lohmeyer J (1997). Phagocytosis of viable *Candida albicans* by alveolar macrophages: lack of opsonin function of surfactant protein A. *J Infect Dis* **175** 2: 421-428.
- Rossiter H, Alon R and Kupper T S (1997). Selectins, T-cell rolling and inflammation. *Mol Med Today* **3** 5: 214-222.
- Rothmann A B, Mortensen H D, Holmskov U and Hojrup P (1997). Structural characterization of bovine collectin-43. *Eur J Biochem* **243** 3: 630-635.
- Rubio S, Lacaze-Masmonteil T, Chailley-Heu B, Kahn A, Bourbon J R and Ducroc R (1995). Pulmonary surfactant protein A (SP-A) is expressed by epithelial cells of small and large intestine. *J Biol Chem* **270** 20: 12162-12169.
- Rudel T, Scheurerpflug I and Meyer T F (1995). *Neisseria* PilC protein identified as type-4 pilus tip-located adhesin. *Nature* **373** 6512: 357-359.
- Rust K, Grosso L, Zhang V, Chang D, Persson A, Longmore W, Cai G Z and Crouch E (1991). Human surfactant protein D: SP-D contains a C-type lectin carbohydrate recognition domain. *Arch Biochem Biophys* **290** 1: 116-126.

- Sakakibara S, Inouye K, Shudo K, Kishida Y, Kobayashi Y and Prockop D J (1973). Synthesis of (Pro-Hyp-Gly)_n of defined molecular weights. Evidence for the stabilization of collagen triple helix by hydroxyproline. *Biochim Biophys Acta* **303** 1: 198-202.
- Sambrook (1986). "Molecular Cloning" *Second ed.*
- Sandlin R C and Stein D C (1994). Role of phosphoglucomutase in lipooligosaccharide biosynthesis in *Neisseria gonorrhoeae*. *J Bacteriol* **176** 10: 2930-2937.
- Sano K, Fisher J, Mason R J, Kuroki Y, Schilling J, Benson B and Voelker D (1987). Isolation and sequence of a cDNA clone for the rat pulmonary surfactant-associated protein (PSP-A). *Biochem Biophys Res Commun* **144** 1: 367-374.
- Sastry K and Ezekowitz R A (1993). Collectins: pattern recognition molecules involved in first line host defense [published erratum appears in *Curr Opin Immunol* 1993 Aug;5(4):566]. *Curr Opin Immunol* **5** 1: 59-66.
- Sastry K, Zahedi K, Lelias J M, Whitehead A S and Ezekowitz R A (1991). Molecular characterization of the mouse mannose-binding proteins. The mannose-binding protein A but not C is an acute phase reactant. *J Immunol* **147** 2: 692-697.
- Schagat T L, Tino M J and Wright J R (1999). Regulation of protein phosphorylation and pathogen phagocytosis by surfactant protein A. *Infect Immun* **67** 9: 4693-4699.
- Schelenz S, Malhotra R, Sim R B, Holmskov U and Bancroft G J (1995). Binding of host collectins to the pathogenic yeast *Cryptococcus neoformans*: human surfactant protein D acts as an agglutinin for acapsular yeast cells. *Infect Immun* **63** 9: 3360-3366.
- Schindler R, Itin C, Zerial M, Lottspeich F and Hauri H P (1993). ERGIC-53, a membrane protein of the ER-Golgi intermediate compartment, carries an ER retention motif. *Eur J Cell Biol* **61** 1: 1-9.
- Schneider H, Griffiss J M, Boslego J W, Hitchcock P J, Zahos K M and Apicella M A (1991). Expression of paragloboside-like lipooligosaccharides may be a necessary component of gonococcal pathogenesis in men. *J-Exp-Med.* 1991 Dec 1; **174** 6: 1601-1605.
- Schneider H, Griffiss J M, Mandrell R E and Jarvis G A (1985). Elaboration of a 3.6-kilodalton lipooligosaccharide, antibody against which is absent from human sera, is associated with serum resistance of *Neisseria gonorrhoeae*. *Infect Immun* **50** 3: 672-677.
- Schneider H, Griffiss J M, Williams G D and Pier G B (1982). Immunological basis of serum resistance of *Neisseria gonorrhoeae*. *J Gen Microbiol* **128** Pt 1: 13-22.

- Schneider H, Hale T L, Zollinger W D, Seid R C, Jr., Hammack C A and Griffiss J M (1984). Heterogeneity of molecular size and antigenic expression within lipooligosaccharides of individual strains of *Neisseria gonorrhoeae* and *Neisseria meningitidis*. *Infect-Immun.* 1984 Sep; **45 3**: 544-549.
- Schoolnik G K, Ochs H D and Buchanan T M (1979). Immunoglobulin class responsible for gonococcal bactericidal activity of normal human sera. *J Immunol* **122 5**: 1771-1779.
- Schwalbe R A, Dahlback B, Coe J E and Nelsestuen G L (1992). Pentraxin family of proteins interact specifically with phosphorylcholine and/or phosphorylethanolamine. *Biochemistry* **31 20**: 4907-4915.
- Schwan E T, Robertson B D, Brade H and van Putten J P (1995). Gonococcal rfaF mutants express Rd2 chemotype LPS and do not enter epithelial host cells. *Mol Microbiol* **15 2**: 267-275.
- Schwartz N B, Pirok E W, 3rd, Mensch J R, Jr. and Domowicz M S (1999). Domain organization, genomic structure, evolution, and regulation of expression of the aggrecan gene family. *Prog Nucleic Acid Res Mol Biol* **62** : 177-225.
- Schweizer A, Kornfeld S and Rohrer J (1996). Cysteine34 of the cytoplasmic tail of the cation-dependent mannose 6-phosphate receptor is reversibly palmitoylated and required for normal trafficking and lysosomal enzyme sorting. *J Cell Biol* **132 4**: 577-584.
- Shafer W M, Joiner K, Guymon L F, Cohen M S and Sparling P F (1984). Serum sensitivity of *Neisseria gonorrhoeae*: the role of lipopolysaccharide. *J Infect Dis* **149 2**: 175-183.
- Sharon N and Lis H (1972). Lectins: cell-agglutinating and sugar-specific proteins. *Science* **177 53**: 949-959.
- Sheriff S, Chang C Y and Ezekowitz R A (1994). Human mannose-binding protein carbohydrate recognition domain trimerizes through a triple alpha-helical coiled-coil [published erratum appears in *Nat Struct Biol* 1996 Jan;3(1):103]. *Nat Struct Biol* **1 11**: 789-794.
- Shimizu H, Fisher J H, Papst P, Benson B, Lau K, Mason R J and Voelker D R (1992). Primary structure of rat pulmonary surfactant protein D. cDNA and deduced amino acid sequence. *J Biol Chem* **267 3**: 1853-1857.
- Simpson D Z, Hitchen P G, Elmhirst E L and Taylor M E (1999). Multiple interactions between pituitary hormones and the mannose receptor. *Biochem J* **343 Pt 2** : 403-411.
- Skubitz K M, Campbell K D, Ahmed K and Skubitz A P (1995). CD66 family members are associated with tyrosine kinase activity in human neutrophils. *J Immunol* **155 11**: 5382-5390.
- Sohma H, Matsushima N, Watanabe T, Hattori A, Kuroki Y and Akino T (1995). Ca(2+)-dependent binding of annexin IV to surfactant protein A and lamellar bodies in alveolar type II cells. *Biochem J* **312 Pt 1**: 175-181.

- Solis D, Feizi T, Yuen C T, Lawson A M, Harrison R A and Loveless R W (1994). Differential recognition by conglutinin and mannan-binding protein of N-glycans presented on neoglycolipids and glycoproteins with special reference to complement glycoprotein C3 and ribonuclease B. *J Biol Chem* **269** **15**: 11555-11562.
- Spence J M, Chen J C and Clark V L (1997). A proposed role for the lutropin receptor in contact-inducible gonococcal invasion of Hec1B cells. *Infect Immun* **65** **9**: 3736-3742.
- Steigbigel R T, Lambert L H, Jr. and Remington J S (1974). Phagocytic and bacterial properties of normal human monocytes. *J Clin Invest* **53** **1**: 131-142.
- Steinman R M (2000). DC-SIGN: a guide to some mysteries of dendritic cells [comment]. *Cell* **100** **5**: 491-494.
- Stevens P A, Wissel H, Sieger D, Meienreis-Sudau V and Rustow B (1995). Identification of a new surfactant protein A binding protein at the cell membrane of rat type II pneumocytes. *Biochem J* **308** **Pt 1**: 77-81.
- Stoolman L M (1989). Adhesion molecules controlling lymphocyte migration. *Cell* **56** **6**: 907-910.
- Strang C J, Slayter H S, Lachmann P J and Davis A E d (1986). Ultrastructure and composition of bovine conglutinin. *Biochem J* **234** **2**: 381-389.
- Strayer D S (1991). Identification of a cell membrane protein that binds alveolar surfactant. *Am J Pathol* **138** **5**: 1085-1095.
- Strayer D S, Pinder R and Chander A (1996). Receptor-mediated regulation of pulmonary surfactant secretion. *Exp Cell Res* **226** **1**: 90-97.
- Strayer D S, Yang S and Jerng H H (1993). Surfactant protein A-binding proteins. Characterization and structures. *J Biol Chem* **268** **25**: 18679-18684.
- Studier F W (1991). Use of bacteriophage T7 lysozyme to improve an inducible T7 expression system. *J Mol Biol* **219** **1**: 37-44.
- Studier F W and Moffatt B A (1986). Use of bacteriophage T7 RNA polymerase to direct selective high-level expression of cloned genes. *J Mol Biol* **189** **1**: 113-130.
- Sukhan A and Wiseman G M (1991). Stimulation by gonococci of chloride ion uptake in human leucocytes in relation to other properties of phagocytosis. *J Med Microbiol* **34** **5**: 285-293.
- Suzuki Y, Eda S, Kawai T, Ohtani K, Kase T, Sakamoto T and Wakamiya N (1997). Characterization of recombinant bovine conglutinin expressed in a mammalian cell. *Biochem Biophys Res Commun* **238** **3**: 856-860.
- Suzuki Y, Fujita Y and Kogishi K (1989). Reconstitution of tubular myelin from synthetic lipids and proteins associated with pig pulmonary surfactant. *Am Rev Respir Dis* **140** **1**: 75-81.

- Swanson J (1978). Studies on gonococcus infection. XII. Colony color and opacity variants of gonococci. *Infect Immun* **19** 1: 320-331.
- Swanson J (1979). Studies on gonococcus infection. XVIII. 125I-labeled peptide mapping of the major protein of the gonococcal cell wall outer membrane. *Infect Immun* **23** 3: 799-810.
- Takayama K, Qureshi N, Hyver K, Honovich J, Cotter R J, Mascagni P and Schneider H (1986). Characterization of a structural series of lipid A obtained from the lipopolysaccharides of *Neisseria gonorrhoeae*. Combined laser desorption and fast atom bombardment mass spectral analysis of high performance liquid chromatography-purified dimethyl derivatives. *J Biol Chem* **261** 23: 10624-10631.
- Taylor M E, Bezouska K and Drickamer K (1992). Contribution to ligand binding by multiple carbohydrate-recognition domains in the macrophage mannose receptor. *J Biol Chem* **267** 3: 1719-1726.
- Taylor M E, Conary J T, Lennartz M R, Stahl P D and Drickamer K (1990). Primary structure of the mannose receptor contains multiple motifs resembling carbohydrate-recognition domains. *J Biol Chem* **265** 21: 12156-12162.
- Taylor M E and Drickamer K (1993). Structural requirements for high affinity binding of complex ligands by the macrophage mannose receptor. *J Biol Chem* **268** 1: 399-404.
- Tennent G A, Butler P J, Hutton T, Woolfitt A R, Harvey D J, Rademacher T W and Pepys M B (1993). Molecular characterization of *Limulus polyphemus* C-reactive protein. I. Subunit composition. *Eur J Biochem* **214** 1: 91-97.
- Tennent G A and Pepys M B (1994). Glycobiology of the pentraxins. *Biochem Soc Trans* **22** 1: 74-79.
- Tenner A J (1993). Functional aspects of the C1q receptors. *Behring Inst Mitt* **93**: 241-253.
- Tenner A J (1999). Membrane receptors for soluble defense collagens. *Curr Opin Immunol* **11** 1: 34-41.
- Thiel S, Baatrup G, Friis-Christiansen P, Svehag S E and Jensenius J C (1987). Characterization of a lectin in human plasma analogous to bovine conglutinin. *Scand J Immunol* **26** 5: 461-468.
- Thiel S, Vorup-Jensen T, Stover C M, Schwaeble W, Laursen S B, Poulsen K, Willis A C, Eggleton P, Hansen S, Holmskov U, Reid K B and Jensenius J C (1997). A second serine protease associated with mannan-binding lectin that activates complement. *Nature* **386** 6624: 506-510.
- Tino M J and Wright J R (1996). Surfactant protein A stimulates phagocytosis of specific pulmonary pathogens by alveolar macrophages. *Am J Physiol* **270** 4 Pt 1: L677-688.

- Tino M J and Wright J R (1999). Glycoprotein-340 binds surfactant protein-A (SP-A) and stimulates alveolar macrophage migration in an SP-A-independent manner. *Am J Respir Cell Mol Biol* **20** 4: 759-768.
- Tino M J and Wright J R (1999). Surfactant proteins A and D specifically stimulate directed actin-based responses in alveolar macrophages. *Am J Physiol* **276** 1 Pt 1: L164-174.
- Tong P Y, Gregory W and Kornfeld S (1989). Ligand interactions of the cation-independent mannose 6-phosphate receptor. The stoichiometry of mannose 6-phosphate binding. *J Biol Chem* **264** 14: 7962-7969.
- Tong P Y and Kornfeld S (1989). Ligand interactions of the cation-dependent mannose 6-phosphate receptor. Comparison with the cation-independent mannose 6-phosphate receptor. *J Biol Chem* **264** 14: 7970-7975.
- Tramont E C (1989). Gonococcal vaccines. *Clin Microbiol Rev* **2** Suppl : S74-77.
- Tramont E C, Sadoff J C and Artenstein M S (1974). Cross-reactivity of *Neisseria gonorrhoeae* and *Neisseria meningitidis* and the nature of antigens involved in the bactericidal reaction. *J Infect Dis* **130** 3: 240-247.
- Tramont E C, Sadoff J C and Wilson C (1977). Variability of the lytic susceptibility of *Neisseria gonorrhoeae* to human sera. *J Immunol* **118** 5: 1843-1851.
- Traub W and Piez K A (1971). The chemistry and structure of collagen. *Adv Protein Chem* **25** : 243-352.
- Ulmer J B, Burke C J, Shi C, Friedman A, Donnelly J J and Liu M A (1992). Pore formation and mitogenicity in blood cells by the class 2 protein of *Neisseria meningitidis*. *J Biol Chem* **267** 27: 19266-19271.
- Ushijima H, Schroder H C, Poznanovic S, Matthes E and Muller W E (1992). Human conglutinin-like protein inhibits infection by the human immunodeficiency virus-1 in vitro. *Res Virol* **143** 2: 97-99.
- Valladeau J, Ravel O, Dezutter-Dambuyant C, Moore K, Kleijmeer M, Liu Y, Duvert-Frances V, Vincent C, Schmitt D, Davoust J, Caux C, Lebecque S and Saeland S (2000). Langerin, a novel C-type lectin specific to Langerhans cells, is an endocytic receptor that induces the formation of Birbeck granules. *Immunity* **12** 1: 71-81.
- Van de Velde H, Von Hoegen I, Luo W, Parnes J R and Thielemans K (1992). The T/B cell antigen, CD5, and the B-cell surface protein, CD72, form a pair of interacting receptors. *Ann N Y Acad Sci* **651** : 443-452.
- van der Merwe P A and Barclay A N (1996). Analysis of cell-adhesion molecule interactions using surface plasmon resonance. *Curr Opin Immunol* **8** 2: 257-261.
- Van Golde L M, Batenburg J J and Robertson B (1988). The pulmonary surfactant system: biochemical aspects and functional significance. *Physiol Rev* **68** 2: 374-455.

- van Iwaarden F, Welmers B, Verhoef J, Haagsman H P and van Golde L M (1990). Pulmonary surfactant protein A enhances the host-defense mechanism of rat alveolar macrophages. *Am J Respir Cell Mol Biol* **2** 1: 91-98.
- Van Iwaarden J F, Shimizu H, Van Golde P H, Voelker D R and Van Golde L M (1992). Rat surfactant protein D enhances the production of oxygen radicals by rat alveolar macrophages. *Biochem J* **286 Pt 1**: 5-8.
- van Iwaarden J F, van Strijp J A, Ebskamp M J, Welmers A C, Verhoef J and van Golde L M (1991). Surfactant protein A is opsonin in phagocytosis of herpes simplex virus type 1 by rat alveolar macrophages. *Am J Physiol* **261 2 Pt 1**: L204-209.
- van Iwaarden J F, van Strijp J A, Visser H, Haagsman H P, Verhoef J and van Golde L M (1992). Binding of surfactant protein A (SP-A) to herpes simplex virus type 1-infected cells is mediated by the carbohydrate moiety of SP-A. *J Biol Chem* **267 35**: 25039-25043.
- van Putten J P, Duensing T D and Carlson J (1998). Gonococcal invasion of epithelial cells driven by P.IA, a bacterial ion channel with GTP binding properties. *J Exp Med* **188 5**: 941-952.
- Vassilakos A, Michalak M, Lehrman M A and Williams D B (1998). Oligosaccharide binding characteristics of the molecular chaperones calnexin and calreticulin. *Biochemistry* **37 10**: 3480-3490.
- Veldhuizen R, Nag K, Orgeig S and Possmayer F (1998). The role of lipids in pulmonary surfactant. *Biochim Biophys Acta* **1408 2-3**: 90-108.
- Veldhuizen R A, Yao L J, Hearn S A, Possmayer F and Lewis J F (1996). Surfactant-associated protein A is important for maintaining surfactant large-aggregate forms during surface-area cycling. *Biochem J* **313 Pt 3**: 835-840.
- Verheul A F, Snippe H and Poolman J T (1993). Meningococcal lipopolysaccharides: virulence factor and potential vaccine component. *Microbiol Rev* **57 1**: 34-49.
- Virji M, Evans D, Hadfield A, Grunert F, Teixeira A M and Watt S M (1999). Critical determinants of host receptor targeting by *Neisseria meningitidis* and *Neisseria gonorrhoeae*: identification of Opa adhesiotopes on the N-domain of CD66 molecules. *Mol Microbiol* **34 3**: 538-551.
- Voelker T A, Herman E M and Chrispeels M J (1989). In vitro mutated phytohemagglutinin genes expressed in tobacco seeds: role of glycans in protein targeting and stability. *Plant Cell* **1 1**: 95-104.
- Voorhout W F, Veenendaal T, Haagsman H P, Verkleij A J, van Golde L M and Geuze H J (1991). Surfactant protein A is localized at the corners of the pulmonary tubular myelin lattice. *J Histochem Cytochem* **39 10**: 1331-1336.
- Voss T, Eistetter H, Schafer K P and Engel J (1988). Macromolecular organization of natural and recombinant lung surfactant protein SP 28-36. Structural homology with the complement factor C1q. *J Mol Biol* **201 1**: 219-227.

- Wallace R B and Miyada C G (1987). Oligonucleotide probes for the screening of recombinant DNA libraries. *Methods Enzymol* **152** : 432-442.
- Wang J Y, Kishore U, Lim B L, Strong P and Reid K B (1996). Interaction of human lung surfactant proteins A and D with mite (*Dermatophagoides pteronyssinus*) allergens. *Clin Exp Immunol* **106** **2**: 367-373.
- Wang J Y, Kishore U and Reid K B (1995). A recombinant polypeptide, composed of the alpha-helical neck region and the carbohydrate recognition domain of conglutinin, self-associates to give a functionally intact homotrimer. *FEBS Lett* **376** **1-2**: 6-10.
- Wang J Y, Shieh C C, You P F, Lei H Y and Reid K B (1998). Inhibitory effect of pulmonary surfactant proteins A and D on allergen- induced lymphocyte proliferation and histamine release in children with asthma. *Am J Respir Crit Care Med* **158** **2**: 510-518.
- Wang Z, Gurel O, Baatz J E and Notter R H (1996). Acylation of pulmonary surfactant protein-C is required for its optimal surface active interactions with phospholipids. *J Biol Chem* **271** **32**: 19104-19109.
- Ward M E, Watt P J and Robertson J N (1974). The human fallopian tube: a laboratory model for gonococcal infection. *J Infect Dis* **129** **6**: 650-659.
- Ware F E, Vassilakos A, Peterson P A, Jackson M R, Lehrman M A and Williams D B (1995). The molecular chaperone calnexin binds Glc1Man9GlcNAc2 oligosaccharide as an initial step in recognizing unfolded glycoproteins. *J Biol Chem* **270** **9**: 4697-4704.
- Watson M L, Kingsmore S F, Johnston G I, Siegelman M H, Le Beau M M, Lemons R S, Bora N S, Howard T A, Weissman I L, McEver R P and et al. (1990). Genomic organization of the selectin family of leukocyte adhesion molecules on human and mouse chromosome 1. *J Exp Med* **172** **1**: 263-272.
- Weaver T E (1998). Synthesis, processing and secretion of surfactant proteins B and C. *Biochim Biophys Acta* **1408** **2-3**: 173-179.
- Weaver T E, Hull W M, Ross G F and Whitsett J A (1985). Intracellular and oligomeric forms of surfactant-associated apolipoproteins(s) A in the rat. *Biochim Biophys Acta* **827** **3**: 260-267.
- Weaver T E, Lin S, Bogucki B and Dey C (1992). Processing of surfactant protein B proprotein by a cathepsin D-like protease. *Am J Physiol* **263** **1 Pt 1**: L95-103.
- Weaver T E and Whitsett J A (1989). Processing of hydrophobic pulmonary surfactant protein B in rat type II cells. *Am J Physiol* **257** **2 Pt 1**: L100-108.
- Weaver T E and Whitsett J A (1991). Function and regulation of expression of pulmonary surfactant-associated proteins. *Biochem J* **273** **Pt 2**: 249-264.
- Weis W I, Crichlow G V, Murthy H M, Hendrickson W A and Drickamer K (1991). Physical characterization and crystallization of the carbohydrate-recognition domain of a mannose-binding protein from rat. *J Biol Chem* **266** **31**: 20678-20686.

- Weis W I and Drickamer K (1994). Trimeric structure of a C-type mannose-binding protein. *Structure* **2** **12**: 1227-1240.
- Weis W I, Drickamer K and Hendrickson W A (1992). Structure of a C-type mannose-binding protein complexed with an oligosaccharide. *Nature* **360** **6400**: 127-134.
- Weis W I, Taylor M E and Drickamer K (1998). The C-type lectin superfamily in the immune system. *Immunol Rev* **163** : 19-34.
- Wert S E, Yoshida M, LeVine A M, Ikegami M, Jones T, Ross G F, Fisher J H, Korfhagen T R and Whitsett J A (2000). Increased metalloproteinase activity, oxidant production, and emphysema in surfactant protein D gene-inactivated mice. *Proc Natl Acad Sci U S A* **97** **11**: 5972-5977.
- Westphal O, Jann K and Himmelspach K (1983). Chemistry and immunochemistry of bacterial lipopolysaccharides as cell wall antigens and endotoxins. *Prog Allergy* **33** : 9-39.
- White M R, Crouch E, Chang D, Sastry K, Guo N, Engelich G, Takahashi K, Ezekowitz R A and Hartshorn K L (2000). Enhanced antiviral and opsonic activity of a human mannose-binding lectin and surfactant protein D chimera. *J Immunol* **165** **4**: 2108-2115.
- White R T, Damm D, Miller J, Spratt K, Schilling J, Hawgood S, Benson B and Cordell B (1985). Isolation and characterization of the human pulmonary surfactant apoprotein gene. *Nature* **317** **6035**: 361-363.
- Whitsett J A, Ross G, Weaver T, Rice W, Dion C and Hull W (1985). Glycosylation and secretion of surfactant-associated glycoprotein A. *J Biol Chem* **260** **28**: 15273-15279.
- Wild J, Robinson D and Winchester B (1983). Isolation of mannose-binding proteins from human and rat liver. *Biochem J* **210** **1**: 167-174.
- Williams M C (1978). Freeze-fracture studies of tubular myelin and lamellar bodies in fetal and adult rat lungs. *J Ultrastruct Res* **64** **3**: 352-361.
- Williams M C, Hawgood S and Hamilton R L (1991). Changes in lipid structure produced by surfactant proteins SP-A, SP-B, and SP-C. *Am J Respir Cell Mol Biol* **5** **1**: 41-50.
- Wintergerst E, Manz-Keinke H, Plattner H and Schlepper-Schafer J (1989). The interaction of a lung surfactant protein (SP-A) with macrophages is mannose dependent. *Eur J Cell Biol* **50** **2**: 291-298.
- Wissel H, Looman A C, Fritzsche I, Rustow B and Stevens P A (1996). SP-A-binding protein BP55 is involved in surfactant endocytosis by type II pneumocytes. *Am J Physiol* **271** **3 Pt 1**: L432-440.
- Wright J R (1997). Immunomodulatory functions of surfactant. *Physiol Rev* **77** **4**: 931-962.

- Wright J R and Clements J A (1987). Metabolism and turnover of lung surfactant. *Am Rev Respir Dis* **136** 2: 426-444.
- Wulfig C and Pluckthun A (1994). Protein folding in the periplasm of *Escherichia coli*. *Mol Microbiol* **12** 5: 685-692.
- Yamanaka N, Kobayashi K, Kataura A, Kuroki Y and Akino T (1991). Implication of surfactant apoprotein in otitis media with effusion. *Ann Otol Rhinol Laryngol* **100** 10: 835-840.
- Yamashita K, Hara-Kuge S and Ohkura T (1999). Intracellular lectins associated with N-linked glycoprotein traffic. *Biochim Biophys Acta* **1473** 1: 147-160.
- York S J, Arneson L S, Gregory W T, Dahms N M and Kornfeld S (1999). The rate of internalization of the mannose 6-phosphate/insulin-like growth factor II receptor is enhanced by multivalent ligand binding. *J Biol Chem* **274** 2: 1164-1171.
- Young N M and Leon M A (1987). The carbohydrate specificity of conglutinin and its homology to proteins in the hepatic lectin family. *Biochem Biophys Res Commun* **143** 2: 645-651.
- Young S L, Fram E K and Larson E W (1992). Three-dimensional reconstruction of tubular myelin. *Exp Lung Res* **18** 4: 497-504.
- Yuan H T, Gowan S, Kelly F J and Bingle C D (1997). Cloning of guinea pig surfactant protein A defines a distinct cellular distribution pattern within the lung. *Am J Physiol* **273** 4 Pt 1: L900-906.
- Zhang Q, Tector M and Salter R D (1995). Calnexin recognizes carbohydrate and protein determinants of class I major histocompatibility complex molecules. *J Biol Chem* **270** 8: 3944-3948.
- Zhou D, Lee N G and Apicella M A (1994). Lipooligosaccharide biosynthesis in *Neisseria gonorrhoeae*: cloning, identification and characterization of the alpha 1,5 heptosyltransferase I gene (rfaC) [published erratum appears in *Mol Microbiol* 1995 Apr;16(1):169]. *Mol Microbiol* **14** 4: 609-618.
- Zhou D, Stephens D S, Gibson B W, Engstrom J J, McAllister C F, Lee F K and Apicella M A (1994). Lipooligosaccharide biosynthesis in pathogenic *Neisseria*. Cloning, identification, and characterization of the phosphoglucomutase gene. *J Biol Chem* **269** 15: 11162-11169.
- Zimmerman P E, Voelker D R, McCormack F X, Paulsrud J R and Martin W J d (1992). 120-kD surface glycoprotein of *Pneumocystis carinii* is a ligand for surfactant protein A. *J Clin Invest* **89** 1: 143-149.

APPENDICES

BUFFERS USED

A	BUFFERS USED	I
A.1	CULTURE MEDIA.....	I
A.2	LB MEDIA PH 7.4	II
A.3	LB AGAR PLATES	II
A.4	WILKINS-CHALGREN ANAEROBE AGAR (G/L).....	II
A.5	BLOOD-AGAR MEDIA (G/L).....	II
A.6	TRYPTIC SOYA BROTH (G/L).....	III
A.7	TRANSFORMATION BUFFERS	III
A.8	1M IPTG STOCK	III
A.9	AMPICILLIN STOCK.....	IV
A.10	CARBENICILLIN STOCK	IV
A.11	CHLORAMPHENICOL STOCK.....	IV
A.12	BIACORE BUFFERS.....	IV
A.13	BIOTINYLATION BUFFERS	IV
A.14	ELISA BUFFERS	IV
A.15	SDS/PAGE BUFFERS	V
A.16	COLUMN BUFFERS	VI
A.17	PROTEASE INHIBITORS COCKTAIL TABLET.....	VII
A.18	SODIUM BARBITAL BUFFER (PH 4.66)	VII
B	VECTOR MAPS.....	VIII
B.1	PET-12A	VIII
B.2	PET-21A	IX
B.3	PET-32A LIC/XA	X
B.4	PMAL-C2.....	XI
C	STRAIN GENOTYPE	XII
C.1	GENOTYPES.....	XII
C.2	HOST GENE DESCRIPTION.....	XII
D	ATCC DESCRIPTION OF HL-60.....	XV
E	SAFETY PERMIT	XVI
F	CRYSTAL STRUCTURE OF CRD OF CONGLUTININ.....	XVII
F.1	CRYSTALLISATION CONDITIONS:	XVII
F.2	RESULTS:.....	XVII
F.3	FIGURE LEGENDS:.....	XVIII

A BUFFERS USED

A.1 Culture Media

A.1.1 LB BROTH (PER LITRE)

10g NaCl
10g Bacto tryptone
5g Yeast extract
pH adjusted to 7.5 with 1N NaOH and autoclaved

A.1.2 RICH MEDIUM (PER LITRE)

10g Tryptone
5g Yeast extract
5g NaCl
2g Glucose
Autoclave and add sterile ampicillin (100µg/ml) or carbenicillin (50µg/ml) and 2g Glucose.

A.1.3 ψ BROTH

0.5% Bactoyeast
2% Bactotryptone
20mM Magnesium sulphate
pH 7.6, adjust with potassium hydroxide and autoclaved

A.1.4 HOGNESS BUFFER

36mM Dipotassium hydrogen phosphate
13mM Potassium dihydrogen phosphate
20mM Trisodium citrate
10mM Magnesium sulphate
40% Glycerol
pH adjusted to 7.0 and autoclaved.

A.2 LB Media pH 7.4

1% (w/v)	Bactotryptone
0.5% (w/v)	Yeast extract
1% (w/v)	NaCl

A.3 LB Agar Plates

1.5% (w/v) bacto-agar in LB medium

A.4 Wilkins-Chalgren Anaerobe Agar (g/l)

10.0	Tryptone
10.0	Gelatin extract
5.0	Yeast extract
1.0	Dextrose
5.0	NaCl
1.0	L-Arginine
1.0	Sodium pyruvate
0.0005	Menadione
1.005	Haemin
10.0	Bacto-agar

The media was dissolved in distilled water, aliquoted and autoclave sterilised.

A.5 Blood-Agar media¹ (g/l)

15.0	Special peptone [§]
1.0	Corn starch
5.0	NaCl
4.0	K ₂ HPO ₄
1.0	KH ₂ PO ₄
10.0	Agar No.1 [‡]

[§] Special peptone (Oxoid) is a mixture of meat and plant enzymatic digests.

¹ Blood Agar containing Isovitalax plates were obtained from the department of Microbiology, John Radcliffe Hospital.

‡ Agar No.1 (Oxoid) is bacteriological agar of very high gel strength (1% w/v) with minimal mineral content.

Vitamin supplement, Isovitalex (2% v/v final concentration) was also added to enrich the media.

A.6 Tryptic Soya Broth (g/l)

17.0	Pancreatic digest of casein
3.0	Papain digest of soyabean meal
5.0	NaCl
2.5	Dibasic potassium phosphate
2.5	Dextrose

The media was aliquoted and autoclave sterilised.

A.7 Transformation Buffers

A.7.1 TFB1

30mM	Potassium acetate
15% (v/v)	Glycerol
10mM	CaCl ₂
100mM	KCl

Autoclaved sterilised and supplemented with filter sterilised 50mM MnCl₂

Stored at 4°C

A.7.2 TFB2

10mM	MOPS (sodium salt)
15% (v/v)	Glycerol
75mM	CaCl ₂
10mM	KCl

Autoclave sterilised and stored at 4°C

A.8 1M IPTG stock

14.1g IPTG (isopropyl-β-D-thiogalactoside)

Final volume adjusted with autoclaved water to 50ml and filter sterilized.

A.9 Ampicillin stock

10mg/ml in sterilized water

A.10 Carbenicillin stock

50mg/ml in sterilized water

A.11 Chloramphenicol stock

34mg/ml or 50mg/ml in 90% ethanol

A.12 BIAcore buffers

10mM HEPES

150mM NaCl

0.02% NaN₃

20mM CaCl₂

0.005% P 20

Elution buffer contained 3mM EDTA

A.13 Biotinylation buffers**A.13.1 BIOTIN-NHS-SS-BIOTIN (10MG/ML STOCK CONCENTRATION)**

2 mg of biotin dissolved in 50µl DMSO and 150µl of water)

A.13.2 BIOTIN LABELLING BUFFER

0.1M NaHCO₃

0.1 M NaCl

(pH 8.3)

A.14 ELISA Buffers

A.14.1 COATING BUFFER

15mM Na₂CO₃
35mM NaHCO₃
0.05% (w/v) NaN₃
pH 9.6

A.14.2 WASHING BUFFER (TBS/NTC)

50mM Tris-Cl
150mM NaCl
0.05% (w/v) NaN₃
0.05% (v/v) Tween-20
2mM CaCl₂

A.14.3 DILUTION BUFFER (TBS/NC)

pH 7.4
50mM Tris-Cl
150mM NaCl
0.05% (w/v) NaN₃
0.05% (v/v) Tween-20
2mM CaCl₂
or
10mM EDTA

A.15 SDS/PAGE buffersA.15.1 2X SAMPLE LOADING BUFFER

100mM Tris-Cl (pH 8.3)
4% w/v SDS
0.2% w/v bromophenol Blue
20% v/v glycerol
40mM Iodoacetamide (unreduced samples)

A.15.2 ACRYLAMIDE GEL SOLUTION

A.15.2.1 SEPARATING GEL SOLUTION (15%)

7.5ml	30% Acrylamide/0.8% bis-acrylamide
3.75ml	0.5mM Tris-Cl/ 0.4% SDS (pH 8.8)
3.75ml	Water
0.05ml	10% Ammonium per sulphate (APS)
0.01 ml	TEMED

A.15.2.2 STACKING GEL SOLUTION (5%)

2.5ml	30% Acrylamide/0.8% bis-acrylamide
3.75ml	0.5mM Tris-Cl/ 0.4% SDS (pH 6.8)
8.75ml	Water
0.05ml	10% Ammonium per sulfate (APS)
0.01 ml	TEMED

A.15.3 GEL RUNNING BUFFER TRIS-GLYCINE (5X)

15.1g	Tris
94g	Glycine
50ml	10% SDS

A.16 Column Buffers**A.16.1 ION EXCHANGE**

20mM	Tris-Cl
5mM	CaCl ₂
50mM	NaCl (low-ionic strength)
1M	NaCl (high-ionic strength)

A.16.2 SUPEROSE-12

20mM	Tris-Cl
5mM	CaCl ₂
or	
100mM	EDTA
150mM	NaCl

A.16.3 AFFINITY PURIFICATION

20mM Tris-Cl

5mM CaCl₂

150mM NaCl

100mM EDTA was used in elution buffer in place of CaCl₂.

A.16.4 AMYLOSE COLUMN BUFFER PH 7.0

20mM Tris-Cl

1mM EDTA

200mM NaCl

optional: 1mM NaN₃

A.17 Protease Inhibitors cocktail tablet

One tablet dissolved in 50ml of buffer gives following concentrations:

(mg/ml)	ENZYME
0.02	Pancrease-extract
0.002	Chymotrypsin
0.0005	Thermolysin
0.02	Trypsin
0.33	Papain

A.18 Sodium Barbitol Buffer (pH 4.66)

0.032M Barbitol sodium

0.029 M Sodium Acetate Trihydrate

0.12 M Sodium Chloride

B VECTOR MAPS

B.1 pET-12a

pET-12a sequence landmarks

T7 promoter	645-661
T7 transcription start	644
<i>ompT</i> coding sequence	516-578
T7 terminator	404-450
pBR322 origin	2848
<i>bla</i> coding sequence	3609-4466

The maps for pET-12b and pET-12c are the same as pET-12a (shown) with the following exceptions: pET-12b is a 4673bp plasmid; subtract 1bp from each site beyond *BamH* I at 510. pET-12c is a 4675bp plasmid; add 1bp to each site beyond *BamH* I at 510.

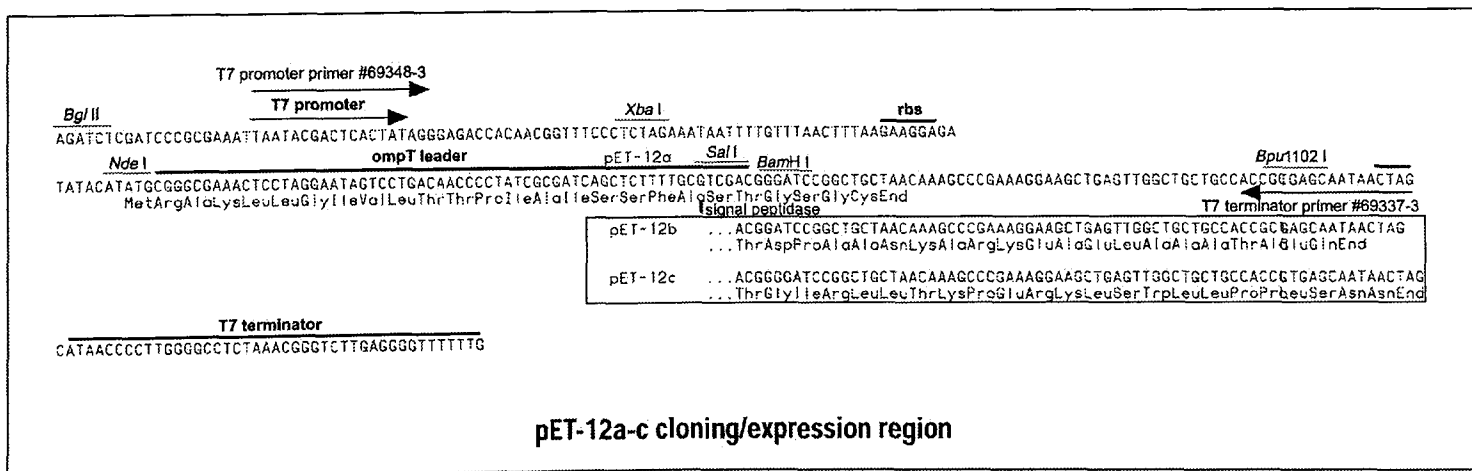
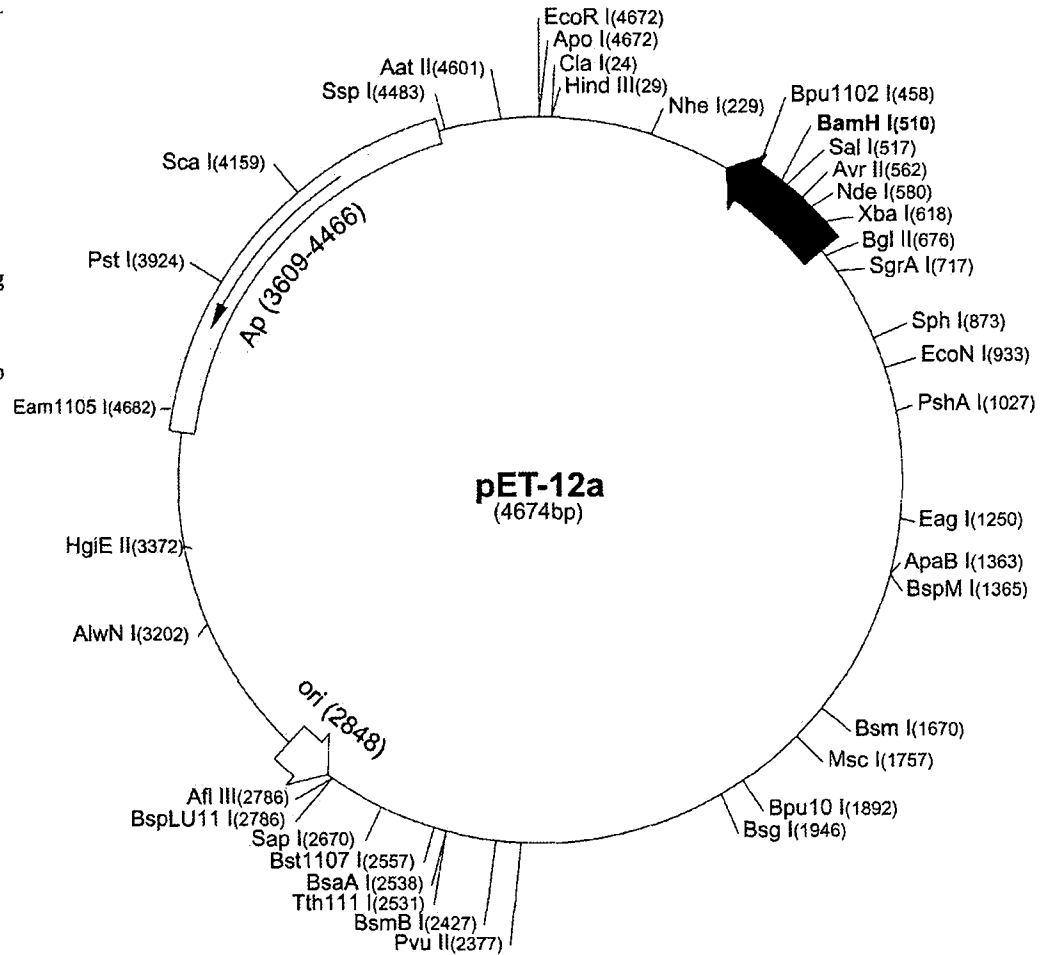

B.2 pET-21a

pET-21a(+) sequence landmarks

T7 promoter	311-327
T7 transcription start	310
T7•Tag coding sequence	207-239
Multiple cloning sites (<i>Bam</i> H I - <i>Xho</i> I)	158-203
His•Tag coding sequence	140-157
T7 terminator	26-72
<i>lacI</i> coding sequence	714-1793
pBR322 origin	3227
<i>bla</i> coding sequence	3988-4845
f1 origin	4977-5432

The maps for pET-21b(+), pET-21c(+) and pET-21d(+) are the same as pET-21a(+) (shown) with the following exceptions:
 pET-21b(+) is a 5442bp plasmid; subtract 1bp from each site beyond *Bam*H I at 198.
 pET-21c(+) is a 5441bp plasmid; subtract 2bp from each site beyond *Bam*H I at 198.
 pET-21d(+) is a 5440bp plasmid; the *Bam*H I site is in the same reading frame as in pET-21c(+). An *Nco* I site is substituted for the *Nde* I site with a net 1bp deletion at position 238 of pET-21c(+). As a result, *Nco* I cuts pET21d(+) at 234, and *Nhe* I cuts at 229. For the rest of the sites, subtract 3bp from each site beyond position 239 in pET-21a(+). *Nde* I does not cut pET-21d(+). Note also that *Sty* I is not unique in pET-21d(+).

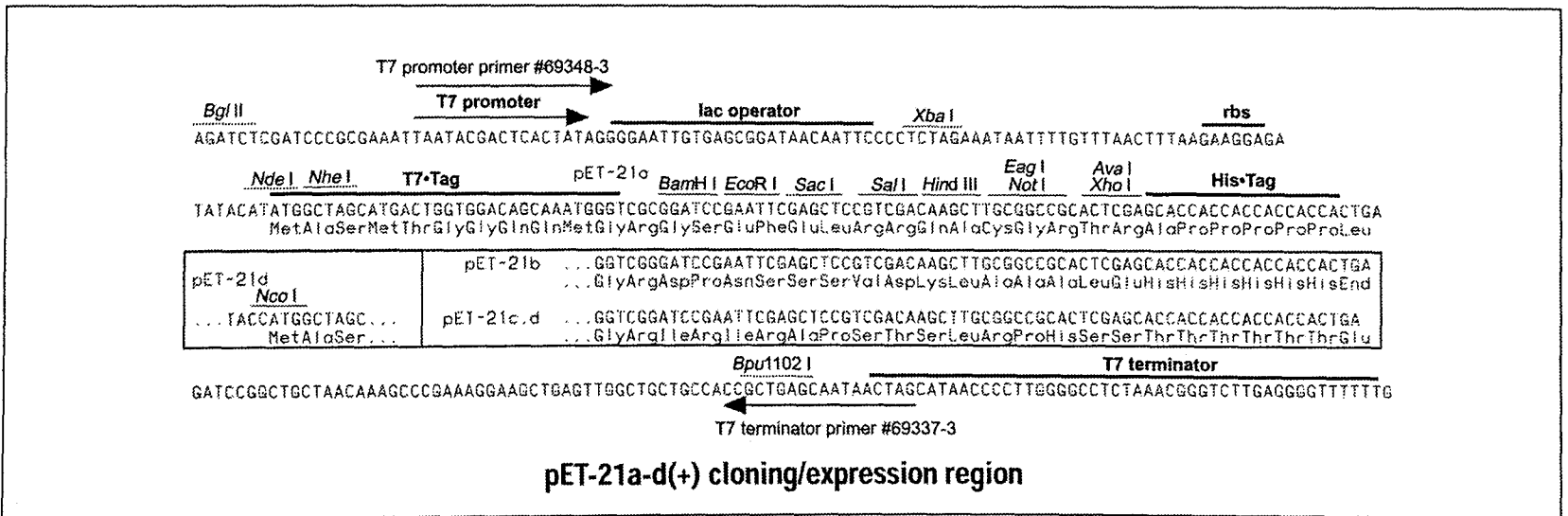
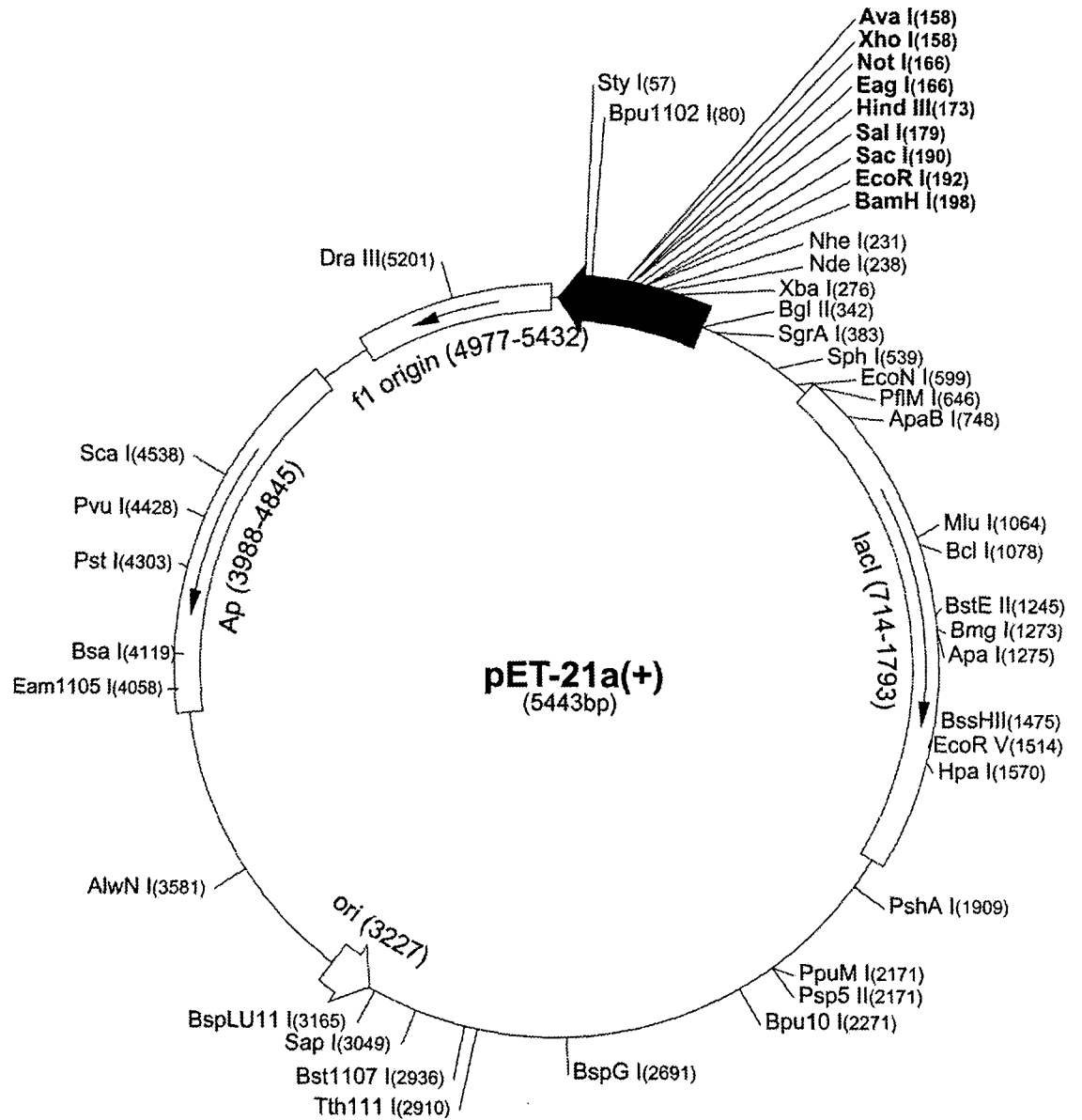

B.3 pET-32a LIC/Xa

pET-32 Xa/LIC sequence landmarks

T7 promoter	790-806
T7 transcription start	789
Trx•Tag coding sequence	392-718
His•Tag coding sequence	353-370
S•Tag coding sequence	275-319
Multiple cloning sites (<i>BseR</i> I - <i>Xho</i> I)	158-225
His•Tag coding sequence	140-157
T7 terminator	26-72
<i>lacI</i> coding sequence	1197-2276
pBR322 origin	3710
<i>bla</i> coding sequence	4471-5328
f1 origin	5460-5915

Notes: the *Srf*I and *Sma*I sites are destroyed during Ligation Independent Cloning.

Primer sequence extensions required for Xa/LIC compatibility are underlined in the diagram below.

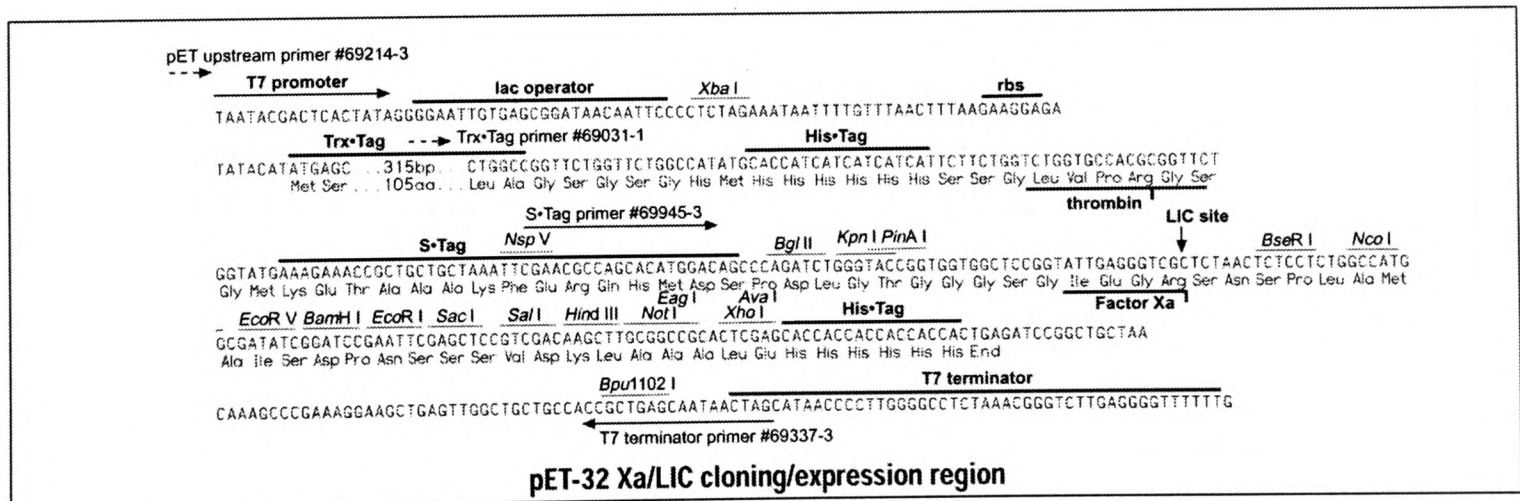
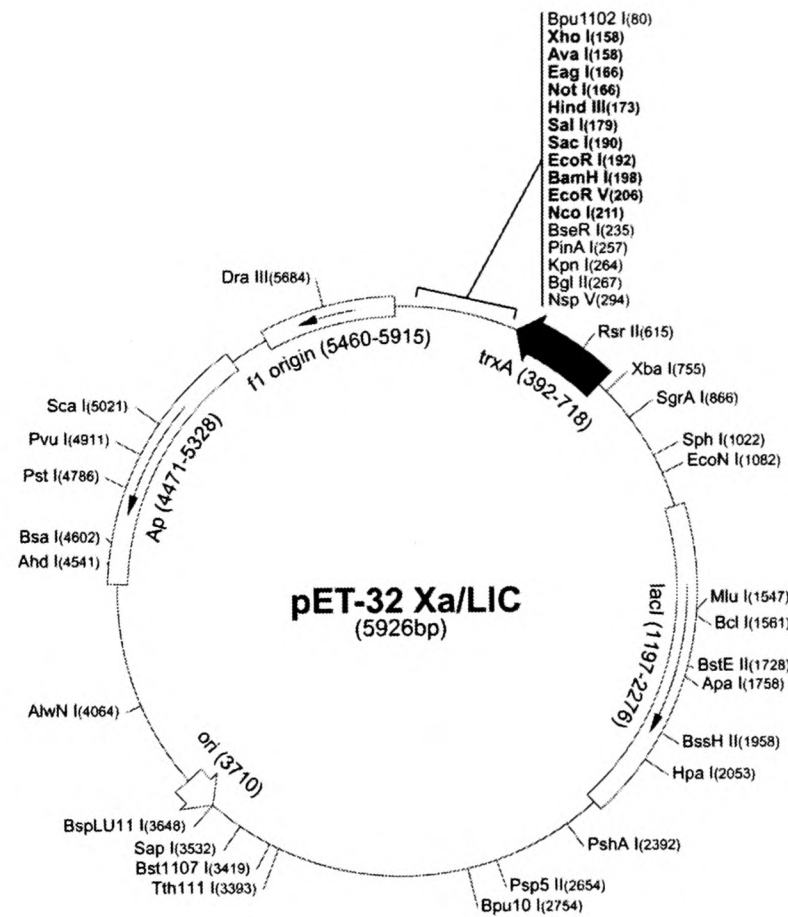
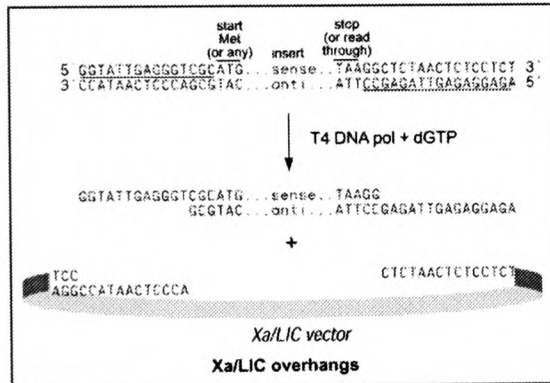

B.4 pMA1-c2

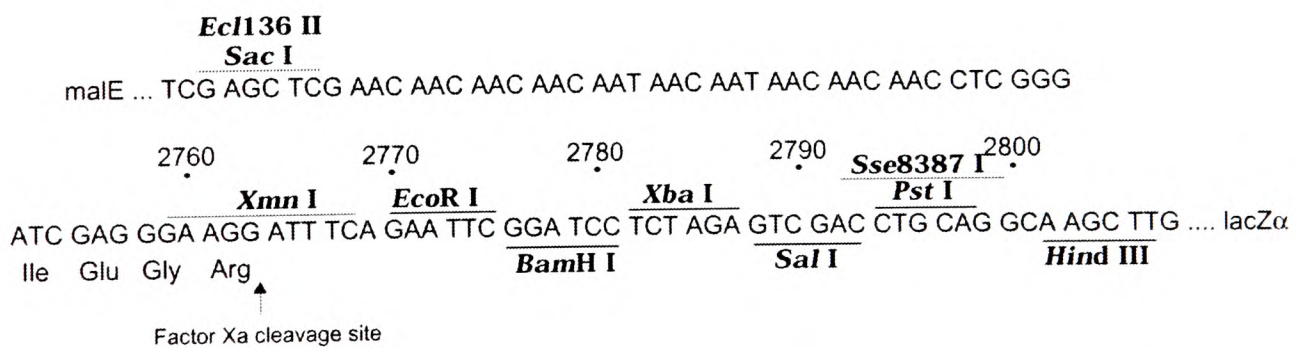
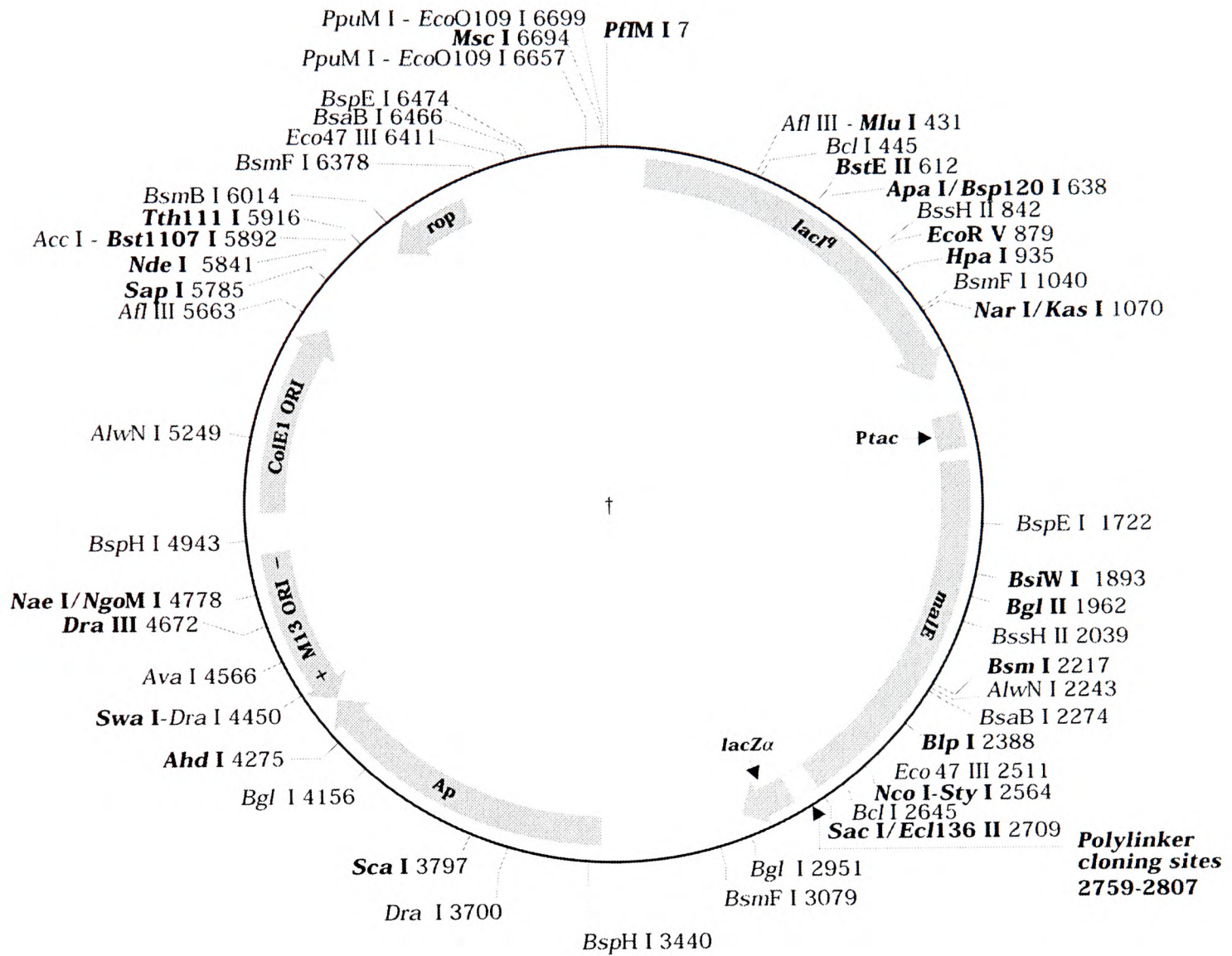

C STRAIN GENOTYPE

C.1 Genotypes

STRAIN	GENOTYPE
BL21(DE3)	F ⁻ <i>ompT hsdS_B (r_B⁻ m_B⁻) gal dcm</i> (DE3)
BL21(DE3)pLysS	F ⁻ <i>ompT hsdS_B (r_B⁻ m_B⁻) gal dcm</i> (DE3) pLysS(CM ^R)
Novablue	<i>endA1 hsdR17 (r_{K12}⁻ m_{K12}⁺) supE44 thi-1 recA1 gyrA96 relA1 lac [F¹proA⁺B⁺lac^IΔM15::Tn10(Tc^R)]</i>
DH5α	F ⁻ φ80d/ <i>lacZΔM15Δ(lacZYA-argF)U169 endA1 recA1 hsdR17(r_K⁻ m_K⁺) deoR thi-1 supE44 λ⁻ gyrA96 relA1</i>
Y1088 [§]	<i>e14⁻(mcrA) Δ(lac)U169 supE supF hsdR metB trpR tonA21 proC:: Tn5 (kan^r) [pMC9 Amp^r tet^r]</i>
AD494(DE3)	<i>Δara-leu7697 ΔlacX74 ΔphoA Pvull phoR ΔmalF3 F¹[lac⁺ (lacI^q)pro] trxB::kan</i> (DE3)

([§]pMc9 is pBR322 with lacI^q inserted)

C.2 Host gene description

<i>ara</i>	Mutation causes inability to use arabinose
<i>endA</i>	DNA specific Endonuclease I Mutation shown to improve yield and quality of DNA from plasmid minipreps.
<i>galK</i>	Inability to utilise galactose.
<i>gyrA</i>	DNA gyrase subunit A; resistance or sensitivity to nalidixic acid; presence of <i>gyr96</i> mutation results in resistance to nalidixic acid.
<i>hfl</i>	High frequency lysogeny. Mutation increases λ lysogeny by inactivating a specific protease
<i>lacI</i>	Repressor protein of lac operon. <i>LacI^q</i> is a mutant of <i>LacI</i> that overproduces the repressor protein.
<i>lacY</i>	Lactose utilisation; galactose permease (M protein)
<i>lacZ</i>	β-D-galactosidase; lactose utilisation. Cells with <i>lacZ</i> mutation produce white colonies in presence of X-gal; wild type produce blue colonies
<i>LacZΔM15</i>	A specific N-terminal deletion which permits the α-

	complementation segment present on the pBluescript [®] phagemid or LambdaZAP [®] II vector to make a functional <i>lacZ</i> protein.
<i>malA</i>	Inability to utilise maltose
<i>proAB</i>	Mutants require proline for growth in minimal media
<i>recA</i>	Gene central to genetic recombination and DNA repair. Mutation eliminates general recombination and renders bacteria sensitive to UV light
<i>recBCD</i>	Exonuclease V. Mutation in <i>recB</i> or <i>recC</i> reduces general recombination to one hundredth of its normal level and affects DNA repair.
<i>recJ</i>	Exonuclease involved in alternate recombination pathways in <i>E. coli</i> .
<i>relA</i>	Relaxed phenotype; permits RNA synthesis in absence of protein synthesis
<i>rpsL</i>	30S ribosomal subunit protein S12. Mutation makes cells resistant to streptomycin; also written <i>strA</i> .
<i>sbcBC</i>	Exonuclease I. Permits general recombination in <i>recBC</i> mutant hosts.
<i>supE</i>	Suppressor of amber (UAG) mutations. Some phages require mutation in this gene in order to grow.
<i>supF</i>	Suppressor of ochre (UGA) mutations. Some phages require a mutation in this gene in order to grow.
<i>thi-1</i>	Mutants require vitamin B1 (thiamine) for growth in minimal media.
<i>traD36</i>	Mutation inactivates conjugal transfer of F' episome.
<i>umuC</i>	Component of SOS repair pathway.
<i>uvrC</i>	Component of UV excision repair pathway
<i>dam</i>	DNA adenine methylase. Mutation blocks methylation of adenine residues in the recognition sequence 5'-G*ATC-3' (*methylated)
<i>xylA</i>	Inability to utilise xylose.
<i>dcm</i>	DNA cytosine methylase. Mutations blocks methylation of internal cytosine residues in the recognition sequences 5'C*CAGG-3' or 5'C*CTGG-3' (*methylated)
<i>hsdM</i>	<i>E. coli</i> (or EcoK) DNA methylase. Mutation blocks sequence-specific adenine methylation in the sequence A ^{N6*} ACNNNNNNGTGC or GC ^{N6*} ACNNNNNNGTT (*Methylated). DNA isolated from a HsdM- strain will be restricted by a HsdR+ host.
<i>hsdR</i>	<i>E. coli</i> (or EcoK) restriction endonuclease. Absence of this activity permits the introduction of DNA propagated from

	non- <i>E. coli</i> sources.
<i>mcrA</i>	<i>E. coli</i> restriction system. Mutation prevents McrA restriction of methylated DNA of sequence 5'-C*CGG (*internal cytosine methylated)
<i>mcrCB</i>	<i>E. coli</i> restriction system. Mutation prevents McrCB restriction of methylated DNA of sequence 5'-G ⁵ C, 5'-G ^{5h} C or 5'-G ^{N4} *C(methylated cytosine). Formerly known as <i>rglA</i> .
<i>mrr</i>	<i>E. coli</i> restriction system. Mutation prevents Mrr restriction of methylated DNA of sequence 5'-G*AC, or 5'-C*AG (methylated adenine). Mutation also prevents Mcrf restriction of methylated cytosine sequences.
<i>hsdS</i>	Specificity determinant for <i>hsdM</i> and <i>hsdR</i> . Mutation eliminates HsdM and HsdR activity.

D ATCC DESCRIPTION OF HL-60

ATCC Number: CCL-240
Organism: Homo sapiens (human)
Designation: HL-60
Tissue: acute promyelocytic leukemia; peripheral blood; promyeloblast
Products: tumor necrosis factor (TNF), also known as tumor necrosis factor alpha (TNF-alpha, TNF alpha), after stimulation with phorbol myristic acid
Receptors Expressed: complement; Fc
Oncogene: myc +
Morphology: myeloblastic
Comments: HL-60 cells spontaneously differentiate and differentiation can be stimulated by butyrate, hypoxanthine, phorbol myristic acid (PMA, TPA), dimethylsulfoxide (DMSO, 1% to 1.5%), actinomycin D, and retinoic acid. The cells exhibit phagocytic activity and responsiveness to chemotactic stimuli. The line is positive for myc oncogene expression.
Age Stage: 36 years
Ethnicity: Caucasian
Gender: female
Reverse Transcript: negative
Growth Properties: suspension
Isoenzymes: G6PD, B; PGM1, 1; PGM3, 1; ES-D,1; Me-2, 1; AK-1, 1; GLO-1, 1
Subculturing: Cultures can be maintained by addition or replacement of medium. Start new cultures at 2×10^5 viable cells/ml and subculture at 1×10^6 cells/ml.
Fluid Renewal: Every 2 to 3 days
Propagation: ATCC medium: Iscove's modified Dulbecco's medium with 4 mM L-glutamine adjusted to contain 1.5 g/L sodium bicarbonate, 80%; fetal bovine serum, 20%
BioSafety Level: 1

E SAFETY PERMIT

Date: Mon, 24 May 1999 12:51:39 +0100 (BST)
From: Susan Robertson <sjr@bioch.ox.ac.uk>
To: Alpana Prasad <alpana@bioch.ox.ac.uk>
Subject: Neisseria gonorrhoea (fwd)

----- Forwarded message -----

Date: Mon, 24 May 1999 12:45:12 +0000
From: Joanna Marshall <joanna.marshall@university-safety-office.oxford.ac.uk>
To: sjr@opal.bioch.ox.ac.uk
Subject: Neisseria gonorrhoea

Susan

To confirm:

No specific licences or authority approvals are required to import Neisseria gonorrhoea from the US. This is subject to the strains not being genetically modified.

The strains will need to be classified as infectious substances and consigned as such for transport (so properly packaged and labelled and shippers declaration on dangerous goods etc etc).

Joanna

Dr Joanna Marshall
Biological Safety Officer
University of Oxford Safety Office
10 Parks Road, Oxford OX1 3PD
Tel: 01865 270819. Fax: 01865 270816
Email: joanna.marshall@safety.ox.ac.uk

F CRYSTAL STRUCTURE OF CRD OF CONGLUTININ

The crystals of CRD of conglutinin were grown by sitting-drop method. The sitting drop contained equal volumes of the reservoir solution and the protein solution (10mg/ml).

F.1 Crystallisation Conditions:

2M ammonium sulphate solution containing 10-18% glycerol (pH 4.5) at 20°C.

F.2 Results:

X-ray data was collected in-house using a MAR300 image plate. The current structure has been refined to 1.78Å resolution with a R-factor of 15% (R-free = 19.0%).

The space group of the crystals is C2 with the unit cell parameters of:

$$a = 83.1 \text{ \AA}$$

$$b = 57.41 \text{ \AA}$$

$$c = 28.51 \text{ \AA}$$

and

$$\beta = 106.9^\circ$$

The structure was solved by molecular replacement method using CRD of human SP-D as an initial model. There are 192 water molecules, 3 glycerol and 2 sulphate molecules in the model. The rms deviation is 0.010 Å for bond length and 1.5° for bond angles from ideality.

F.3 Figure legends:

Fig A: The calcium binding sites of conglutinin. In the crystal structure these two sites are occupied by water molecules. Residue 317 that forms the part of the calcium binding site (top one in the picture) is disordered.

Fig B: The ribbon diagram of the CRD showing various structural features of the domain.

Fig C: Superimposed C α traces of conglutinin (green) and SP-D (red). 113 out of 119 residues can be superimposed with SP-D with a rms deviation of 0.55Å for the C α atoms.

Fig D: Superimposed C α traces of conglutinin (green) and MBL (red). 99 out of 119 residues of BC could be superimposed with those of MBL with 0.64 Å.

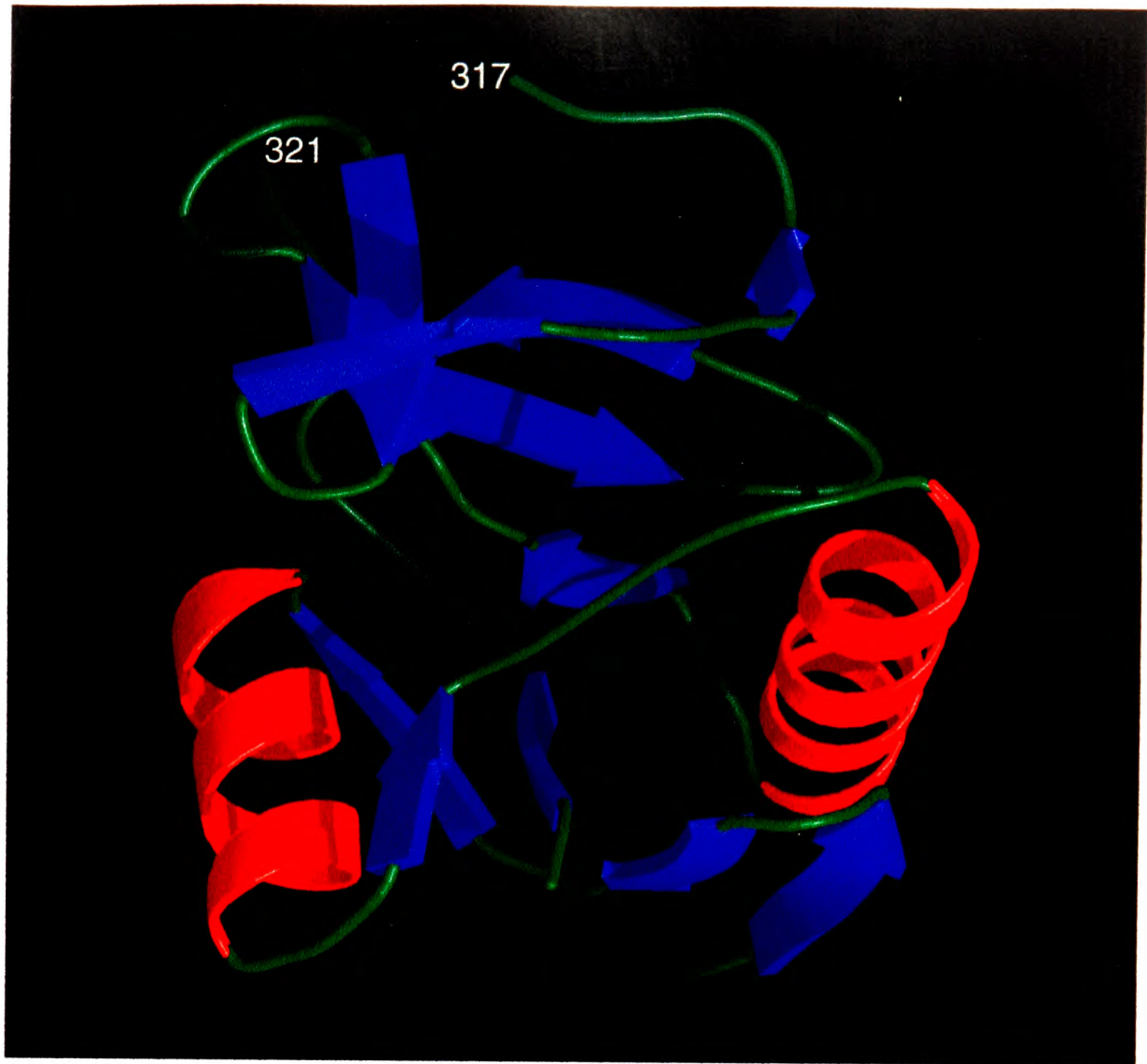

A

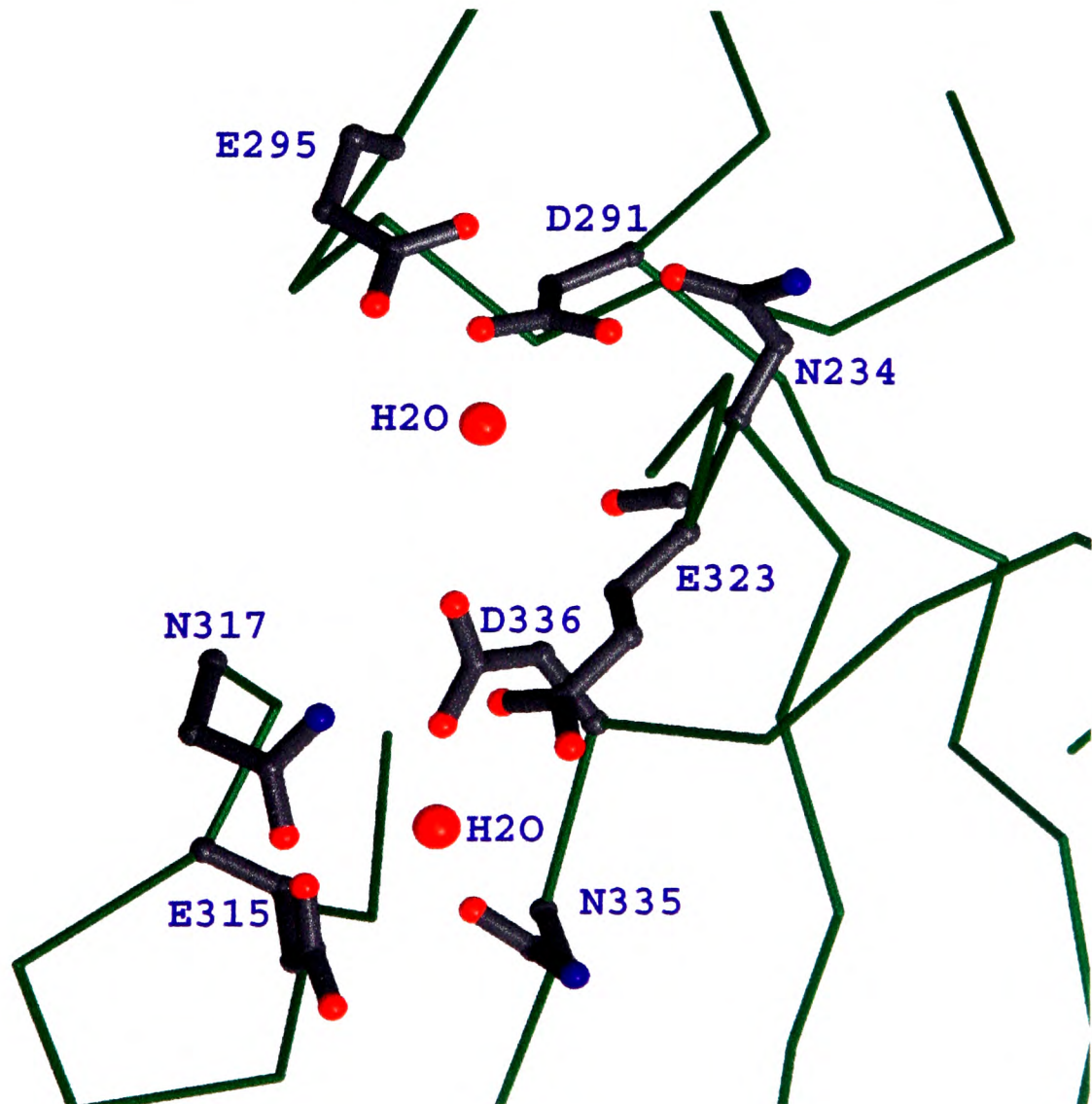

B

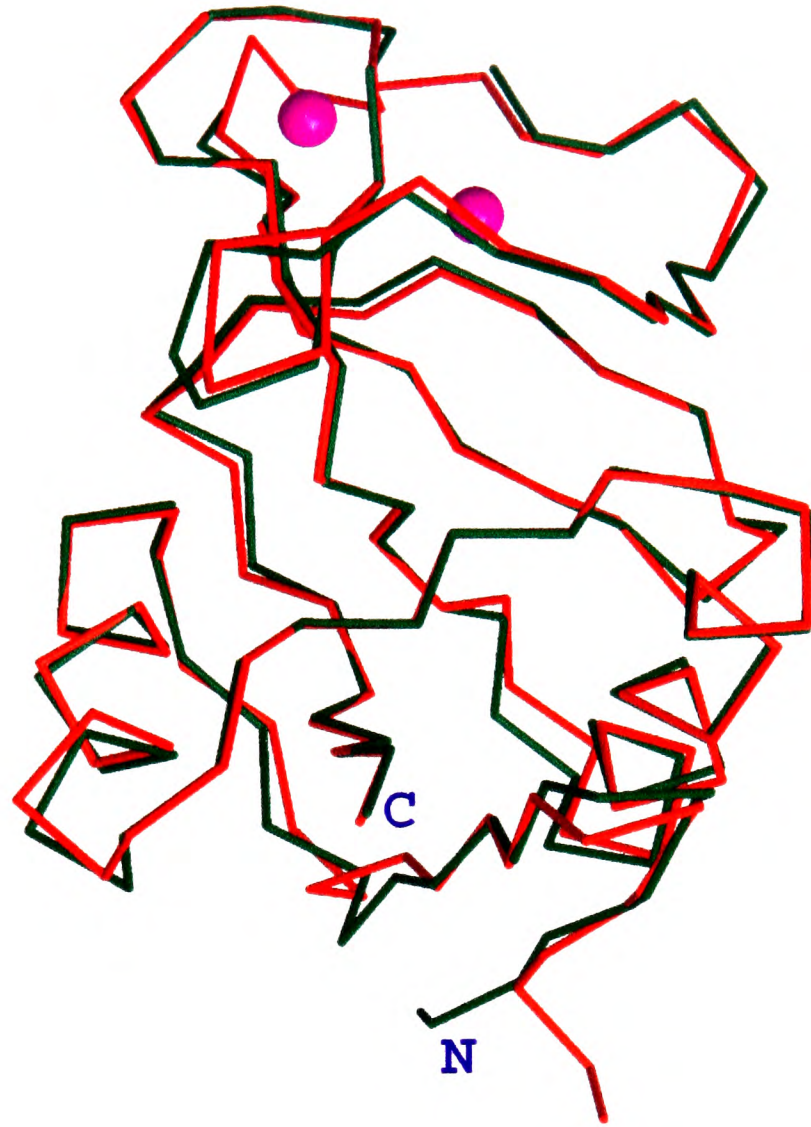

C)

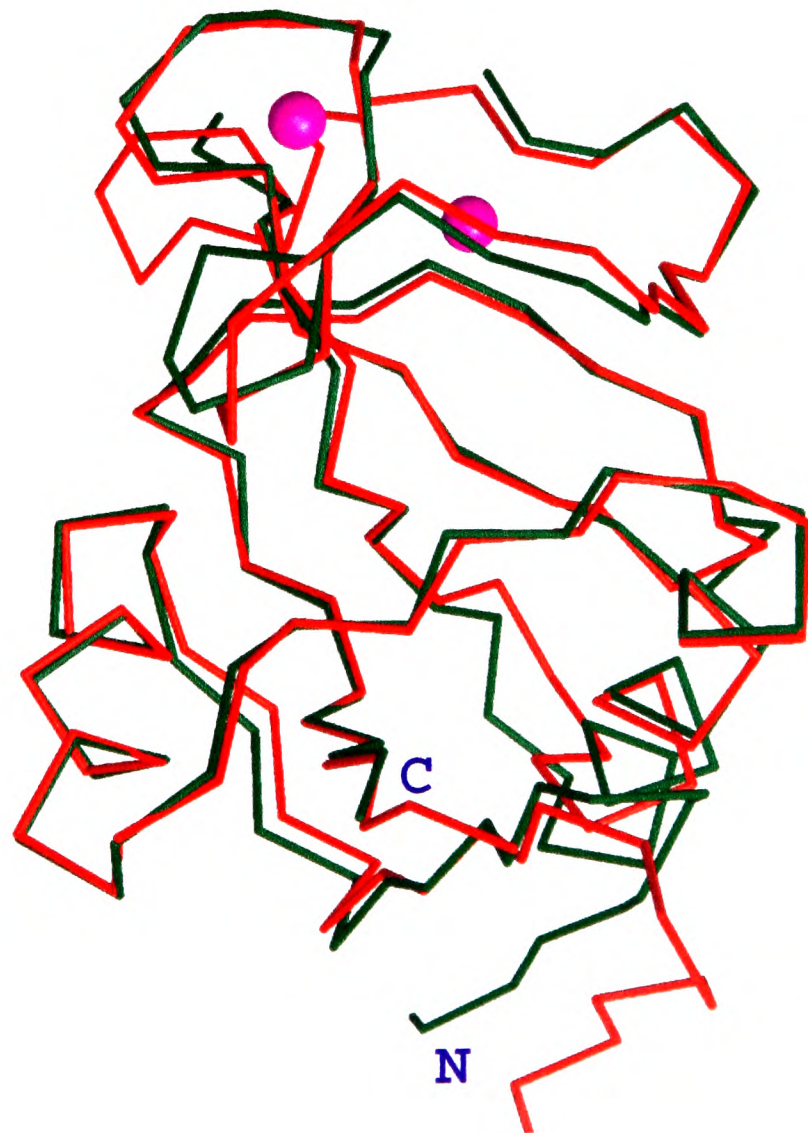

D)