

ASPECTS OF THE SYNTAX  
OF PREPOSITIONS AND PREPOSITIONAL PHRASES  
IN ENGLISH AND POLISH

A Thesis submitted for the Degree of D.Phil.,  
Trinity Term, 1986.

Ewa Jaworska  
St. Hugh's College

Abstract

The present thesis focusses on the structure of PP's in English and Polish, and the occurrence of PP's in subject and object positions. The main theoretical references are the X-bar Theory of syntactic categories and the Government Binding framework (GB).

A consideration of English data corroborates Jackendoff's and Emonds' claim that apart from an NP, prepositions can take a PP and an  $\bar{S}$  complement or no complement at all, though details of Jackendoff's analysis are revised. Polish prepositions allow the same range of complements, including no complement, although, with a greater variety of complex prepositions and with intransitive prepositions modified by relative and appositive clauses, the P-PP and the P- $\bar{S}$  structures are less common in Polish than in English.

Subject and object PP's have so far received little attention. Like PP objects of prepositions, they are used if the intended meaning cannot be expressed by a suitable NP. The appearance of subject PP's in raising and passive sentences poses a problem for classical Transformational Grammar, though not for a slightly revised version of GB -- another category-based framework. The analysis proposed here involves a particular view of the representation of Case, and a revised Case

Filter. The Case Filter rules out not merely any lexical NP with no Case but any lexical XP which requires Case but has not been assigned Case. Thus, the properties of being an NP and requiring Case are independent of each other.

It emerges from the investigation (i) that prepositions in English and Polish are more alike than one might expect, given the obvious differences between the two languages; (ii) that prepositions and PP's are like verbs and VP's -- as Jackendoff emphasizes -- but in some respects they show greater resemblance to other categories; and (iii) that syntactic categories are less important for the distribution of phrases than is commonly assumed, and that the meaning of phrases is of central importance for their distribution.

ASPECTS OF THE SYNTAX  
OF PREPOSITIONS AND PREPOSITIONAL PHRASES  
IN ENGLISH AND POLISH

by

Ewa Jaworska



A Thesis submitted for the Degree of  
Doctor of Philosophy  
in the  
University of Oxford

St. Hugh's College  
Trinity Term  
1986 [i.e. 1987] MI

## CONTENTS

|   |    |
|---|----|
| Chapter 1   |    |
| INTRODUCTION .....                                  | 1  |
| 1.1. Preliminary remarks .....                      | 1  |
| 1.2. The generative approach .....                  | 3  |
| 1.3. The organization of the thesis .....           | 6  |
| 1.4. The theoretical background .....               | 12 |
| 1.4.1. X-bar Theory .....                           | 12 |
| 1.4.2. The Government-Binding framework .....       | 18 |
| 1.5. Some remarks on Polish work on syntax .....    | 22 |
| 1.5.1. The general approach .....                   | 22 |
| 1.5.2. The status of Polish prepositions .....      | 26 |
| Notes to Chapter 1 .....                            | 30 |
| Chapter 2   |    |
| INTRANSITIVE PREPOSITIONS .....                     | 33 |
| 2.1. Introduction .....                             | 33 |
| 2.2. Intransitive prepositions in English .....     | 34 |
| 2.3. Intransitive prepositions in Polish .....      | 38 |
| 2.4. Conclusion .....                               | 49 |
| Notes to Chapter 2 .....                            | 51 |
| Chapter 3   |    |
| THE P-P-NP STRINGS IN ENGLISH .....                 | 55 |
| 3.1. Introduction .....                             | 55 |
| 3.2. Jackendoff's proposal .....                    | 56 |
| 3.2.1. A summary .....                              | 56 |
| 3.2.2. An objection .....                           | 58 |
| 3.3. Revisions .....                                | 60 |
| 3.3.1. Complex prepositions .....                   | 60 |
| 3.3.2. Prepositions with PP complements .....       | 62 |
| 3.3.3. Non-constituents .....                       | 72 |
| 3.3.4. Prepositions as specifiers .....             | 77 |
| 3.4. Wider implications of the P-PP structure ..... | 84 |
| 3.5. Conclusion .....                               | 88 |
| Notes to Chapter 3 .....                            | 92 |

|   |     |
|---|-----|
| Chapter 4   |     |
| COMPLEX ADVERBIAL CONSTRUCTIONS IN ENGLISH .....                | 96  |
| 4.1. Introduction .....   | 96  |
| 4.2. Previous analyses .....                                    | 99  |
| 4.2.1. PP's <u>with</u> a clausal complement .....              | 99  |
| 4.2.2. Bare <u>S</u> 's .....                                   | 105 |
| 4.2.3. PP's with a complex NP complement .....                  | 114 |
| 4.2.4. PP's with a free relative complement .....               | 118 |
| 4.3. PP's with a clausal complement revisited .....             | 123 |
| 4.3.1. The simple cases .....                                   | 123 |
| 4.3.2. Some obvious extensions .....                            | 125 |
| 4.3.3. Some questionable extensions .....                       | 129 |
| 4.4. PP's with a clausal complement and the CRP .....           | 132 |
| 4.5. Conclusion .....   | 134 |
| Notes to Chapter 4 .....  | 136 |
| Chapter 5   |     |
| THE P-P-NP STRINGS IN POLISH .....                              | 139 |
| 5.1. Introduction .....   | 139 |
| 5.2. Complex prepositions .....                                 | 140 |
| 5.3. Prepositions with PP complements .....                     | 146 |
| 5.4. Conclusion .....   | 154 |
| Notes to Chapter 5 .....  | 155 |
| Chapter 6   |     |
| COMPLEX ADVERBIAL CONSTRUCTIONS IN POLISH .....                 | 156 |
| 6.1. Introduction .....   | 156 |
| 6.2. PP's with a clausal complement .....                       | 157 |
| 6.2.1. The case of <i>mimo</i> .....                            | 157 |
| 6.2.2. The case of <i>podczas</i> .....                         | 162 |
| 6.3. Bare <u>S</u> 's .....                                     | 168 |
| 6.4. PP's with a modifying clause .....                         | 172 |
| 6.4.1. PP's with a relative clause .....                        | 172 |
| 6.4.2. PP's with an appositive clause .....                     | 179 |
| 6.5. Conclusion .....   | 186 |
| Notes to Chapter 6 .....  | 188 |
| Chapter 7   |     |
| PP's IN TYPICAL NP POSITIONS: AN OVERVIEW .....                 | 190 |
| 7.1. Introduction .....   | 190 |
| 7.2. Identifying subject and object PP's .....                  | 193 |
| 7.2.1. Subject PP's in English .....                            | 193 |
| 7.2.2. Subject PP's in Polish .....                             | 198 |
| 7.2.3. Object PP's .....  | 205 |
| 7.3. The category status of subject and object PP's .....       | 208 |
| 7.4. Some characteristics of PP's in typical NP positions ..... | 210 |
| 7.5. Some theoretical considerations .....                      | 219 |
| Notes to Chapter 7 .....  | 224 |
| Chapter 8   |     |
| SUBJECT AND OBJECT PP's: A GB ANALYSIS .....                    | 226 |
| 8.1. Introduction .....   | 226 |
| 8.2. Raising and passive constructions in GB .....              | 227 |
| 8.3. Subject PP's and the CRP .....                             | 233 |
| 8.4. The analysis .....   | 235 |
| 8.5. Conclusion.....  | 244 |
| Notes to Chapter 8 .....  | 246 |

|   |     |
|---|-----|
| Chapter 9   |     |
| SOME FURTHER CONSIDERATIONS .....                               | 248 |
| 9.1. Introduction.....  | 248 |
| 9.2. Other categories as subjects and objects .....             | 248 |
| 9.3. Adverbial NP's .....                                       | 254 |
| 9.4. More on inherent Case .....                                | 261 |
| 9.5. Passive without movement .....                             | 265 |
| 9.6. Conclusion .....   | 267 |
| Notes to Chapter 9 .....  | 269 |
| Chapter 10  |     |
| CONCLUDING REMARKS .....  | 271 |
| 10.1. Introduction .....  | 271 |
| 10.2. Prepositions and PP's in English and Polish .....         | 271 |
| 10.3. Prepositions and PP's, and other categories .....         | 274 |
| 10.4. Syntactic categories and the distribution of phrases .... | 279 |
| 10.5. Further research .....                                    | 285 |
| REFERENCES .....  | 287 |

## CHAPTER 1

### INTRODUCTION

#### 1.1. Preliminary remarks

In recent work in syntactic theory, prepositions and prepositional phrases have featured most prominently in discussions of movement phenomena. The main focus has been on sentences like *Who did you talk to?* and *A solution was arrived at*, which involve a phenomenon known as 'preposition stranding'. Few works, however, have been devoted entirely or primarily to prepositions and prepositional phrases, and relatively little attention has been paid to other aspects of their syntax. The book where these categories are the primary object of research, van Riemsdijk 1978, is principally concerned with preposition stranding.

The present thesis is devoted almost entirely to prepositions (P's) and prepositional phrases (PP's), and, broadly speaking, to two aspects of their syntax. These are: (i) the structure of certain PP's, and (ii) the appearance of PP's as subjects and objects. The languages to be considered are English and Polish. The general approach is that of generative grammar, and the main theoretical references are to X-bar Theory of syntactic categories and to the Government-Binding framework. My starting point is the assumption that prepositions are heads of phrases. My goal is to contribute to the description of English and Polish grammar, and to the development of grammatical theory. In the remainder of this chapter, details of this brief characterization will

be spelled out and the essential background will be provided.

The fundamental syntactic properties of the category 'preposition' were brought to the attention of theoretical linguists in an article opening with the following challenge:

'People seem never to have taken prepositions seriously. One proposal in print (Fillmore (1968)) treats prepositions as case markers, having equal status with the case inflections of Latin and German. Another proposal (Postal (1971)) treats them as realizations of features on noun phrases. Still another (Becker and Arms (1969)) tries to reduce prepositions to a subclass of the category "verb." What all these proposals have in common is that they deny that the category "preposition" has any intrinsic syntactic interest other than as an annoying little surface peculiarity of English.' (Jackendoff 1973: 345)

Taking up his own challenge, Jackendoff 1973, 1977 presented data from English, disregarded in the cited works, which led him to the conclusion that prepositions constitute a lexical category like verbs, nouns, and adjectives, heading phrases and taking complements from a range of phrasal categories or not taking a complement at all, rather than being restricted to co-occurring with noun phrases. The idea that some prepositions do not take a complement at all is due to Emonds 1972. In descriptions of English outside the generative tradition, the data 'discovered' by Jackendoff and Emonds were noted in Jespersen 1924, 1927, and in Quirk *et al.* 1972. Jackendoff must be credited, however, with making their importance fully explicit.

Many linguists have accepted Jackendoff's position, though some theoretical works have failed to appreciate all its implications. In the present thesis, this position will be endorsed on the basis of a re-examination of Jackendoff's English data and strengthened by an examination of Polish data. It will also be opposed to, and defended against, the prevailing view expressed in Polish work on Polish grammar, in which prepositions are not regarded as heads of phrases. It will be shown, however, that some details of Jackendoff's (1973) original

analysis and its extensions in Emonds (1976: 172-175) and Jackendoff (1977: 33, 78-79) are not entirely satisfactory and must be revised. Finally, the importance of the category 'prepositional phrase' will be highlighted further through an examination of sentences where PP's occur as subjects and objects.

### 1.2. The generative approach

Before I outline the contents of the thesis, some remarks about the generative approach are in order. The generative approach, which has been dominant in the study of syntax in the last twenty years or so needs little introduction. It has been repeatedly described by its major proponent, Noam Chomsky, most recently in Chomsky 1985, and it is embodied not only in a variety of specialist research work on syntax but also in linguistics textbooks, e.g. Fromkin and Rodman 1978, Lyons 1981, Brown 1984, and Radford 1981. Therefore, I shall only briefly reiterate those of its features that are directly relevant to the present work.

The aim of the generative study of language is to develop a theory of grammar that will accommodate the grammar of any human language. This aim is pursued through a systematic investigation and description of various aspects of the grammar of individual languages. A central feature of generative work is its concern with explicit formulation and justification of analyses. Although any human language is a legitimate object of study, the development of a theory obviously depends on examining languages with properties relevant to the issues in hand.

In the present context, English and Polish are suitable objects of study because they both have prepositions and prepositional phrases (although, as we shall see, the idea that Polish has prepositional phrases has been questioned in Polish work on grammar).

As in many other languages, prepositions in Polish are typically followed by an NP in constituents that usually function as complements and adverbials. Unlike in English, the case form of the NP in Polish varies with the choice of a preposition. My investigation of the structure of PP's in Polish can be seen in part as a response to Jackendoff's passing remark that regarding prepositions as a lexical category like verbs, nouns, and adjectives, and case markers as affixes attached to NP's 'allows a more unified theory of case marking in languages such as German and Russian, which have a mixture of prepositional phrases and cases' (1977: 80-81). Since Polish is just such a language, it clearly is relevant to an evaluation of this view.

As a method of collecting data for linguistic research, the generative approach gives priority to judgements of native speakers of particular languages about the well-formedness or 'acceptability' of strings of words. It is assumed that acceptable strings of words (usually sentences) are 'grammatical', i.e. conform to the rules of grammar. Data may also come from spontaneously produced utterances or written texts gathered by linguists (corpora), or from an experiment designed to elicit examples with particular syntactic features. An advantage of the first method of data collection over corpus-based research is that it gives the linguist instant access to a particular type of acceptable sentence which might be missing from a corpus. An advantage of this method over both corpus-based and experimental methods is that it allows the linguist to obtain information not only about which strings of words are acceptable but also which are unacceptable, which is crucial for the formulation of analyses and the testing of their validity (cf. Cohen 1981: 240-241).

The standard practice among generative linguists in obtaining acceptability judgements is to use themselves as informants if they are native speakers of the language under investigation and to consult other speakers with a similar background. If they are not native speakers of the language under investigation, they rely on other informants.

On the whole, acceptability judgements offered by informants are reliable and can be confirmed by other native speakers of the language under investigation. Sometimes, however, this is not the case. An example may be initially rejected if judgement is affected by non-grammatical factors. For instance, a prescriptivist ruling may lead an English speaker to reject a sentence like (1.1), containing a 'split infinitive',

(1.1) I find it difficult *to really understand* what exactly  
is required.

or a Polish speaker to reject a sentence with the first person singular subject pronoun:<sup>1</sup>

(1.2) *Ja napisałam list.*  
I wrote letter  
'I wrote a letter.'

In other situations, an example may be judged unacceptable if it poses perceptual problems. Thus, the linguist must exercise caution in interpreting certain judgements, especially negative ones, as they may have nothing to do with syntactic well-formedness of a given string of words.

In the case of unclear acceptability status of strings of words, where an informant cannot give a definite judgement or where a number of informants disagree with each other, the linguist will let his analysis decide whether such marginal examples are grammatical or not. (See Newmeyer (1983: 53-55) for illustrations of such cases.)

Since grammatical descriptions developed by generative linguists are not intended to be accounts of language use, the fact that a particular sentence is acceptable only in a certain communicative situation has generally no effect on the formulations of statements about its grammaticality. Thus, informants' judgements as to whether a sentence is appropriate in, e.g. formal or informal speech or writing, or what stylistic qualities it has (emphatic, focussing, or parenthetical) are usually not relevant to grammatical description although such information may be of some importance in the case of marginal data.

The data presented in this thesis come from a number of sources. As a native speaker of Polish, I have mainly relied on my own acceptability judgements of Polish examples but I have also consulted other Polish speakers. Many of my English examples are drawn from previous work referred to in the discussion, and British English native speakers have confirmed most of 'the American authors' judgements. The acceptability status of newly-constructed English examples has been judged by informants. The informants in both languages had similar linguistic backgrounds.

### 1.3. The organization of the thesis

Set in this general approach, the present thesis is organized as follows. The first five chapters following this one deal with the

structure of certain PP's in the two languages, and the next three, with the occurrence of PP's as subjects and objects, and some related phenomena. The final chapter draws together the conclusions that have emerged and adds some further relevant remarks.

In Chapter 2, I consider the claim advanced by Jespersen 1924 and Emonds 1972 that certain lexical items in English should be analyzed as 'intransitive' prepositions, and I argue that this view is well-motivated not only in English but also in Polish. In particular, I shall argue that Polish spatial and temporal demonstratives like *stąd* 'from-here' and *przedtem* 'beforehand' are intransitive prepositions.

In Chapter 3, I re-examine Jackendoff's (1973) discussion of English strings of two prepositions and a noun phrase (NP), the P-P-NP strings. According to Jackendoff, where such strings form a single constituent, they are instances of a PP consisting of a preposition with a PP complement. (1.3) contains some of his examples and a simple tree diagram illustrating the proposed structure.

- (1.3) a. A great howl of pain emerged *from inside the rain barrel*.  
 b. The nine black riders appeared *out of the darkness*.  
 c. Sam disappeared *down into the darkness*.

d.

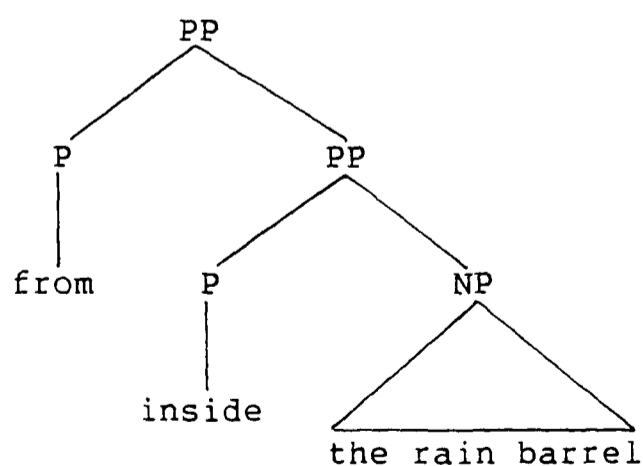

I shall argue that while this structure is appropriate for some of the P-P-NP strings considered by Jackendoff (e.g. that in (1.3a)), other structures are associated with other strings.

In Chapter 4, I am concerned with the structure of complex adverbial constructions (CAC's), the so-called 'adverbial' clauses. According to Emonds (1976: 172, 175) and Jackendoff (1977: 33, 78-79), they are all PP's consisting of a preposition with a clausal ( $\bar{S}$ ) complement. (1.4) contains some of their examples and a simple tree diagram illustrating the proposed structure.

(1.4) a. They left *before the ball was over*.

b. Mary cried *because John left*.

c.

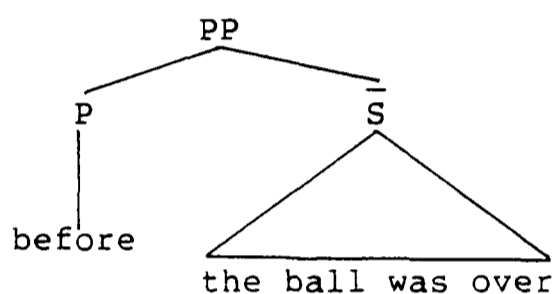

It will be argued that while this structure is appropriate for some complex adverbials (e.g. that in (1.4a)), the case for analyzing all such adverbials as PP's is not very strong and that adverbials like that in (1.4b) may well be  $\bar{S}$ 's rather than PP's.

Data that must be analyzed in terms of the P-PP structure or the P- $\bar{S}$  structure undermine two theoretical proposals concerning the distribution of syntactic categories: Hoekstra's (1984) Unlike Category Condition predicts that PP's do not appear as complements of prepositions, and Stowell's (1981) Case Resistance Principle predicts that neither PP's nor  $\bar{S}$ 's appear as complements of prepositions.

Having re-examined and modified somewhat the analyses of the English data, I turn to Polish. In Chapter 5, I investigate Polish P-P-NP strings. Of particular interest are examples like (1.5),

(1.5) *Odłożmy ten problem na po malowaniu.*

let's-postpone this problem for after decorating

'Let's postpone this problem for after the decorating.'

which contain P-P-NP strings whose structure is P-PP (cf. (1.3d) above).

The structure of Polish complex adverbial constructions is discussed in Chapter 6. The sentences in (1.6) contain some relevant examples.

(1.6) a. *Przyszli, mimo że nie mieli zaproszenia.*

they-came despite that not they-had invitation

'They came despite the fact that they didn't have an invitation.'

b. *Wyszli przedtem, zanim skończył się seans.*

they-left beforehand before finished PRT show

'They left before the show finished.'

c. *Wyjechał dlatego, że stracił pracę.*

he-left therefore that he-lost work

'He left because he'd lost his job.'

Such constructions have been described in the Polish literature, but not very satisfactorily. I shall argue that they are all PP's, the first one being an instance of the P- $\bar{S}$  structure (cf. (1.4c) above). Given the argument developed in Chapter 2, the other two constructions in (1.6) consist of an intransitive preposition and a modifying clause, relative and appositive, respectively. The analysis is further motivated by certain cross-categorial considerations.

Polish data which must be analyzed as involving intransitive prepositions, and the P-PP and the P- $\bar{S}$  structures provide good evidence in favour of regarding Polish prepositions as heads of phrases. They also further undermine the Unlike Category Condition and the Case Resistance Principle.

In the next two chapters, I turn my attention to an aspect of the distribution of PP's in the two languages. The occurrence of PP's in subject and object positions in English is noted in passing in Jespersen (1927: 5) and in Quirk et al. (1985: 658). The first sentence in (1.7) comes from Quirk et. al. and the second from Jespersen.

(1.7) a. *Between six and seven suits me fine.*

b. *He spent from eleven to one at the church.*

Only PP's as subjects have been discussed within the generative tradition. This rather untypical occurrence of PP's recalls the occurrence of PP's as complements of prepositions discussed in the earlier chapters. What all these constructions have in common is that they contain a PP in a position with which an NP is normally associated.

In Chapter 7, I establish that certain PP's in English and Polish are indeed subjects and objects, and that they must be analyzed as bare PP's rather than PP's embedded within NP's. Given that, raising and passive sentences with PP's in subject position are problematic for classical Transformational Grammar because the raising and passive transformations are formulated in terms of movement of an NP.

In Chapter 8, I turn to an analysis of sentences with subject and object PP's within the Government-Binding framework. Having noted that Stowell's (1981) treatment of the data is unsatisfactory, I propose a revision of Case Theory. The central elements of the revised Case Theory

are a particular approach to Case and Case assignment, and a Case Filter which requires not only NP's but also other categories to be Case marked under a certain condition.

In Chapter 9, I examine a number of other constructions, which lend support to the proposed analysis. These are sentences with phrases other than NP's and PP's in subject and object positions and sentences with NP's in the adverbial position, which is a typical PP position. I also ask why inherently Case marked NP's do not appear in positions in a sentence to which structural Case is not assigned and why no movement is involved in some English passives.

In the final chapter, I sum up the results of the investigation. I first summarize the similarities and differences between English and Polish prepositions and PP's that have emerged in the preceding chapters. Next, I compare some properties of prepositions and PP's with the properties of the other main lexical and phrasal categories. Finally, I consider the role of syntactic categories in sentence structure in the light of my consideration of subject and object PP's, referring in particular to the proposals of Pesetsky 1982 and Jackendoff 1983, 1985. I also note areas for further research.

In concentrating on the issues described above, I inevitably ignore other issues involving prepositions and prepositional phrases. I make no contribution to the long-standing debate about extraction from PP's or to the more recent debate about 'small clauses' -- constructions with a subject and a predicate but with no verb -- some of which may be of the category PP (e.g. the string *this sailor off the ship* in *I want this sailor off the ship*). I do not undertake a study of various subtle semantic properties of the constructions I discuss, nor do I enter into considerations of the relation between particular case forms in Polish, prepositions, and meaning.

I am also not discussing the potentially relevant ideas of two works which only became available to me during the final stages of research. One is Chomsky 1986, which contains revisions of certain aspects of the Government-Binding framework of Chomsky 1981, 1982. The other work is Emonds' (1985) discussion of syntactic categories, which pays considerable attention to prepositions and revises some assumptions of the Government-Binding framework.

#### 1.4. The theoretical background

##### 1.4.1. X-bar Theory

We can turn now to the theoretical background and terminology relevant to the investigation. First, I shall outline the X-bar Theory of syntactic categories, and then the Government-Binding framework, which incorporates a version of X-bar Theory.

X-bar Theory is a theory concerned both with syntactic categories and with some aspects of syntactic structure. It has been assumed in a number of generative frameworks. It has its origins in the works of Harris 1951 and Chomsky 1970, but the most detailed study is in Jackendoff 1977. In what follows, I shall present it essentially as it is assumed within the Government-Binding framework, following Chomsky 1981 and subsequent work.

Syntactic categories are divided into 'lexical', and 'intermediate phrasal' and 'full phrasal'. The main lexical categories are nouns (N's), verbs (V's), adjectives (A's), and prepositions (P's). They are defined in terms of the categorial features  $\pm N$  and  $\pm V$ , as is illustrated in the following table:

|       |       |       |
|-------|-------|-------|
|       | [+ N] | [- N] |
| [+ V] | A     | V     |
| [- V] | N     | P     |

Table 1.1.  
Lexical features and categories

In this system, certain properties shared by, e.g. verbs and prepositions are seen as properties of the 'super-category' [- N]. Ordinary adverbs are regarded as a sub-type of the category 'adjective' (Emonds 1976: 12-23; Jackendoff 1977: 32), but it is often convenient to label them ADV's and refer to them as if they were a separate category. I shall adopt this practice in later chapters.

Other lexical categories include determiners (DET's), conjunctions, and intensifiers (INT's). Among them, there is also the category 'complementizer' (COMP) and the category 'inflection' (INFL). The former, broadly speaking, corresponds to the class of 'subordinating conjunctions'. The latter is a category unique to the Government-Binding framework. It consists of the feature  $\pm$  TENSE, a complex of 'agreement' (AGR) features, and modal verbs (Chomsky 1981: 18, 52; 1985: 160-161). It is somewhat reminiscent of the category 'auxiliary' (AUX) in classical Transformational Grammar. I return to COMP and INFL below.

The main lexical categories, defined by the features  $\pm$  N and  $\pm$  V, have associated intermediate and full (or 'maximal') phrasal projections. The latter are informally labelled as NP (noun phrase), VP (verb phrase), AP (adjective phrase), PP (prepositional phrase), and ADVP (adverb phrase).

Formally, syntactic categories are analyzed as complex entities, composed of categorial features and a specification of whether a category is full phrasal, intermediate phrasal, or non-phrasal, i.e. lexical. The latter is commonly represented by the appropriate number of 'bars'. The maximal projection is  $\bar{\bar{X}}$  ('x-double-bar'), where X stands for a categorial feature complex associated with a particular lexical category. The intermediate projection is  $\bar{X}$  ('x-bar'). Lexical category symbols have no bars associated with them. They are represented as a bare X or as an  $X^0$  ('x-zero').

As an illustration of the use of complex category symbols, I present the diagram in (1.8), which represents the structure of the phrase *right on that little table*.

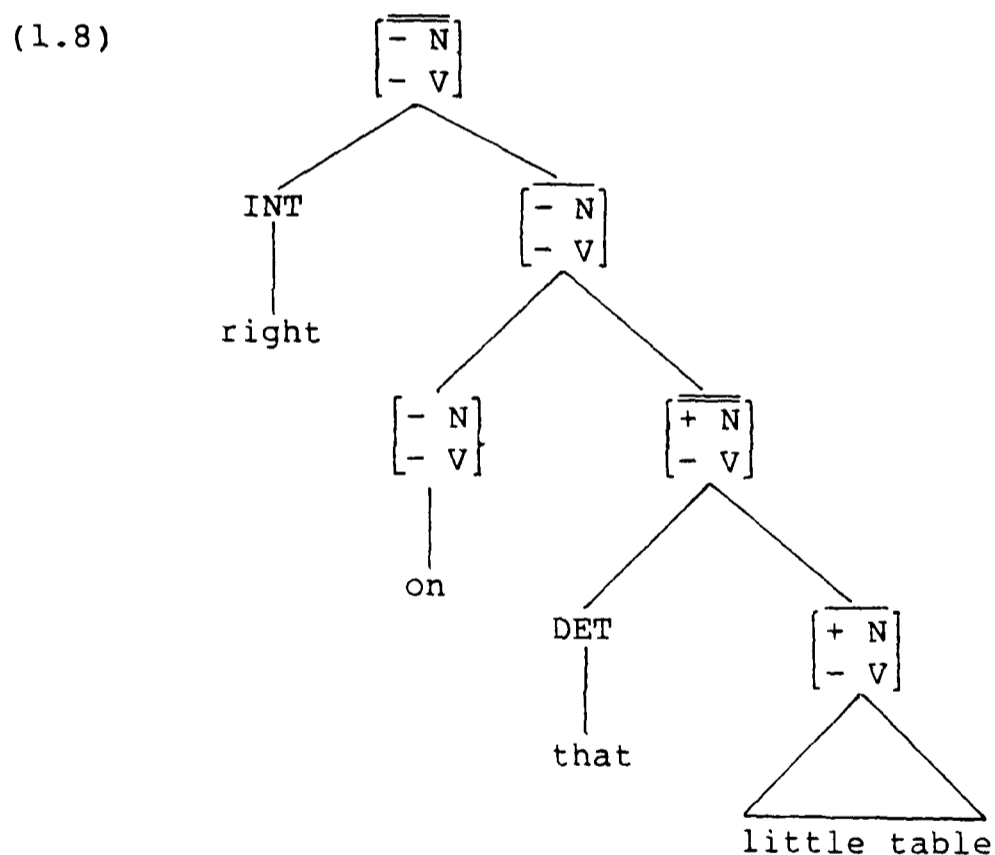

For most illustrative purposes, the complex category symbols can be replaced by simpler, more conventional symbols, such as in (1.9), which is equivalent to (1.8).

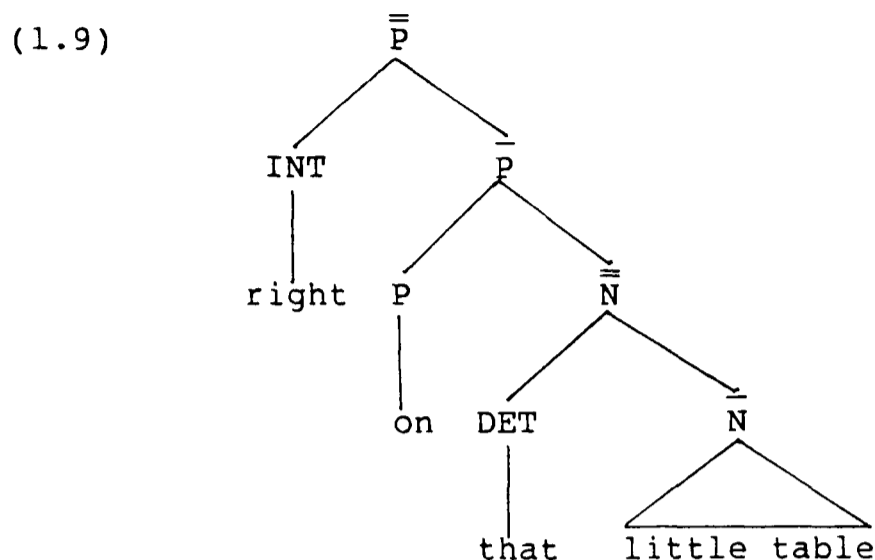

This notation will be adopted throughout the thesis almost without exception in tree diagrams, labelled bracket representations of structure, and in lexical entries. Elsewhere, 'NP', 'PP', etc. will be used as abbreviations for particular maximal projections. A triangle will be used to abbreviate the structure of a constituent that need not be made fully explicit.

Let us now examine the diagram in (1.9). The top node  $\bar{\bar{P}}$  has the intermediate constituent  $\bar{P}$  as one of its 'daughters'. This, in turn, has the lexical category  $P$  as one of its daughters. The  $P$  is the 'head' of  $\bar{P}$ , and the  $\bar{P}$  is the head of  $\bar{\bar{P}}$ . The  $P$  can also be called the head of  $\bar{\bar{P}}$ . Similarly, the  $\bar{N}$  is headed by the  $\bar{N}$ , and this is headed by an  $N$  immediately dominating *table*. We can say that a head is the category which is identical to its immediately dominating ('mother') node, with the possible exception of the number of bars, which may be lower than the number of bars of the mother.<sup>2</sup> Thus, heads determine the identity of phrases.

In addition to the head, the  $\bar{P}$  in (1.9) contains a 'complement' and the  $\bar{\bar{P}}$  contains a 'specifier'. It is generally assumed that complements are daughters of  $\bar{X}$  and specifiers, daughters of  $\bar{\bar{X}}$ . In other words, complements are 'sisters' of lexical categories, and specifiers are

sisters of  $\bar{X}$ 's. The diagram in (1.10) is a schematic representation of the structure of a constituent.

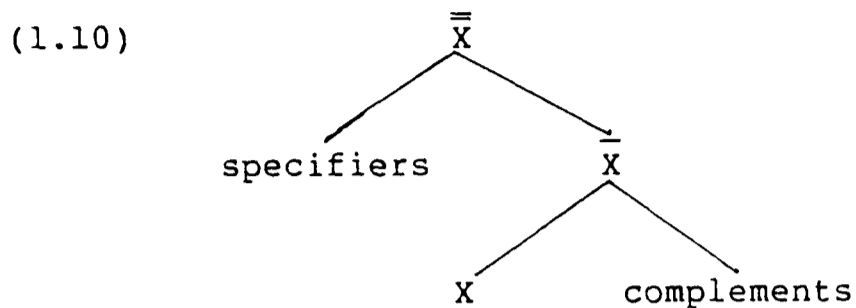

A complement is a maximal projection required, or 'subcategorized for', by a lexical head. For example, the verb *believe* subcategorizes for an NP complement (e.g. *believe the story*), a PP complement (e.g. *believe in a dream*), or a clausal complement (e.g. *believe that dreams come true*), and the preposition *with* subcategorizes for an NP complement (e.g. *with a knife*). Some members of major lexical categories do not require a complement (e.g. nouns or verbs like *collapse*). Complements of certain verbs ('transitive' verbs) are sometimes referred to as 'objects', and complements of prepositions are sometimes referred to as 'objects of prepositions'. A specifier, e.g. the determiner *that* and the intensifier *right* in (1.9), is not subcategorized for by a lexical category although its occurrence and form often depend on the head (e.g. the choice of the determiner depends on the number of the noun as in *\*those table vs this table*). We can say, then, that -- in addition to determining the identity of phrases -- heads largely determine the structure of phrases.

We can now turn to the structure of the clause ( $\bar{S}$ ). Its informal representation is given in (1.11).

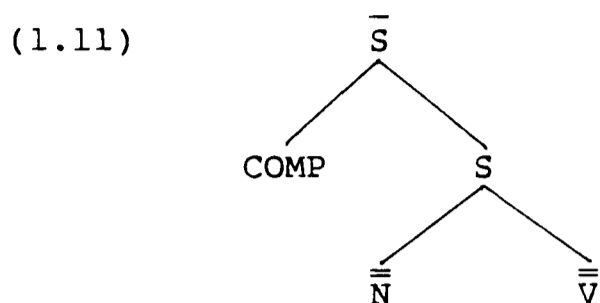

$\bar{S}$  is a constituent containing a bare clause  $S$  and a  $COMP$  node.  $S$ , in turn, consists of at least an  $NP$  and a  $VP$ . The  $COMP$  node can be filled by a member of the lexical category 'complementizer' (e.g. *that*, *whether*, or *for* in English and *że* 'that' or *czy* 'whether' in Polish) or by a fronted *wh*-phrase, or be empty.<sup>3</sup> These possibilities are illustrated in (1.12)-(1.14) with English examples. Labelled brackets mark the relevant parts of the structure.

(1.12) We knew [ $\bar{S}$  [ $COMP$  that][ $S$  she would come]].

(1.13) Peter met the man [ $\bar{S}$  [ $COMP$  whom][ $S$  Tom admires]].

(1.14) We knew [ $\bar{S}$  [ $COMP$  e][ $S$  he would come]].

Within the Government-Binding framework, the following two alternative structures for  $S$  and  $\bar{S}$  have been postulated:

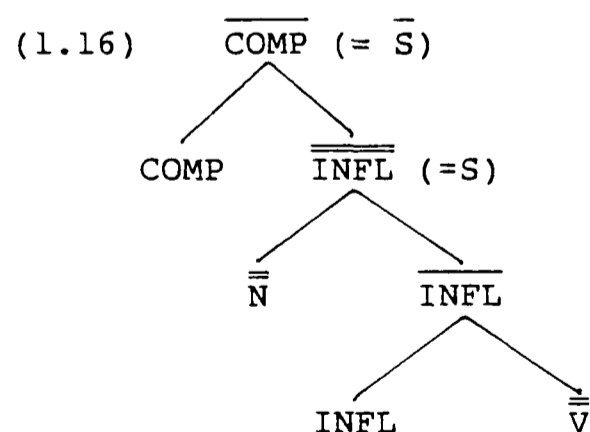
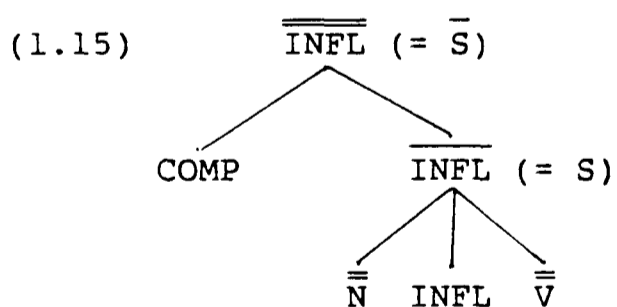

The structure in (1.15) is suggested in Chomsky (1981: 52), and the structure in (1.16) is assumed in Stowell (1981: 67, 388) and Chomsky (1985: 161).<sup>4</sup>

According to (1.15), S is an intermediate projection of INFL and COMP is a specifier.  $\bar{S}$  is the maximal projection of INFL.

According to (1.16), COMP is the head of  $\bar{S}$ . Like (1.15), (1.16) also contains the element INFL but INFL and VP form a constituent,  $\overline{\text{INFL}}$ . (This is reminiscent of the 'predicative phrase' of Chomsky (1965: 102).) S is now the maximal projection of INFL.

Given either of these structures, INFL is like the main lexical categories in having phrasal projections, and given (1.16), COMP is as well.

In Chapter 4, I shall consider both structures in the context of a discussion of English complex adverbial constructions. Otherwise, for the sake of convenience, I shall use a simplified version of structure (1.15), replacing  $\overline{\text{INFL}}$  and  $\overline{\text{INFL}}$  with the more familiar labels  $\bar{S}$  and S, respectively, as is illustrated in (1.17).

(1.17)

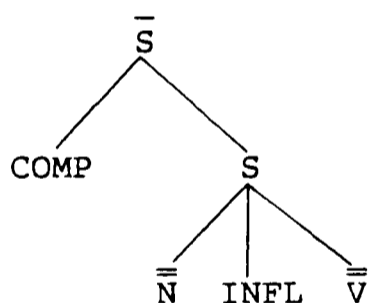

#### 1.4.2. The Government-Binding framework

Let us look now at the Government-Binding framework (henceforth, GB). This is the most prominent theoretical framework currently assumed within generative grammar. It has developed from classical Transformational Grammar in the work of Chomsky 1973, 1977, 1980, and a large number of other American and European linguists.<sup>5</sup> Because previous theoretical discussions of the structure of PP's have assumed a transformational framework, and because some research specifically into

the occurrence of PP's in typical NP positions has been carried on within GB, this thesis will assume its validity.

In this sub-section, I shall outline the basic tenets of GB and introduce the notions 'government' and 'Case'. Since the main focus on GB is in Chapters 8 and 9, and since before then, aspects of the framework will only be referred to in passing, it seems appropriate to hold over the introduction of further relevant details until later parts of the discussion.

As presented in Chomsky 1981, GB is a transformational framework consisting of a number of sub-theories interacting with each other to define the syntactic structures of the language. The diagram below, taken from Hoekstra (1984: 22), illustrates the organization of the grammar.

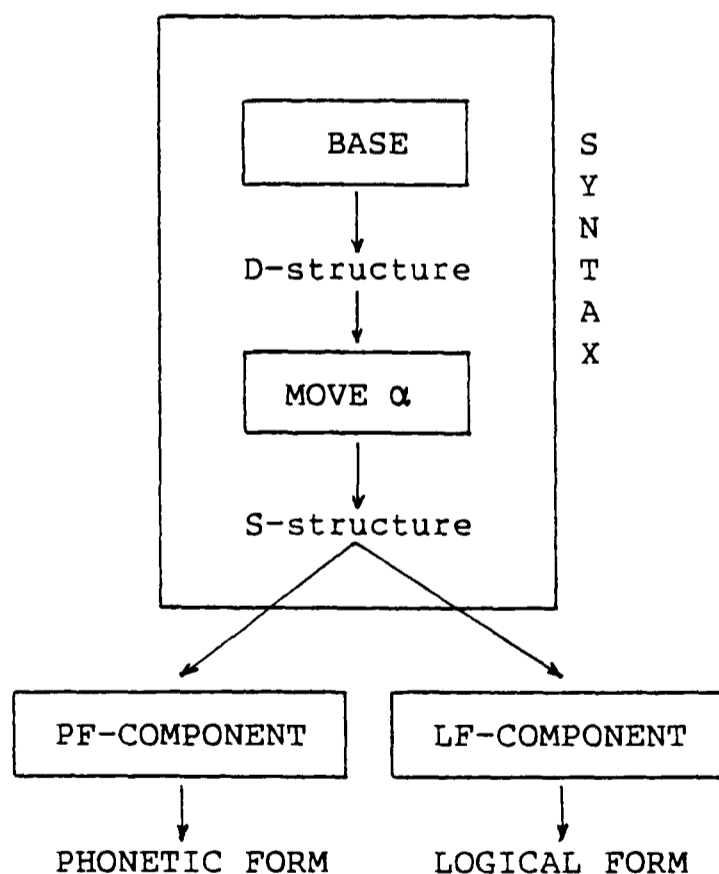

The 'base' consists of certain conditions on phrase structures and the lexicon. The conditions largely follow from the principles of X-bar Theory. The lexicon contains lexical entries of lexical items. The entries include statements about the category of a given item and its

subcategorization properties. (1.18) is an example of a lexical entry of *put*.

$$(1.18) \left[ \begin{array}{l} \textit{put} \\ [+V, -N] \\ + [ \_ \overline{N} \overline{P} ] \end{array} \right]$$

It follows from this entry that *put* is a verb which takes two complements: an NP and a PP. The so-called 'Projection Principle' (Chomsky 1981: 29; 1985: 82) will, among other things, ensure that these complements will appear as sisters of the verb in 'D-structure' (or 'deep' structure).<sup>6</sup>

Other information can be included in lexical entries of verbs, such as what 'theta' (or semantic) roles they assign to their complements (Theme, Patient, Goal, etc.), whether or not they participate in the assignment of a theta role to the subject of a sentence, or what case they require of their NP complements. Lexical entries for other lexical categories will include other types of information. For example, gender and countability will be specified in the lexical entries of nouns.

The transformational component consists of just one optional transformation 'move  $\alpha$ ', which moves maximal projections (and some lexical categories) from their original position to some other position within the structure. Informally, we can distinguish 'wh-movement' and 'NP-movement' as two major instances of move  $\alpha$ . The vacated node is filled by a 'trace' (t) of the moved category, an empty category coindexed with it.

'S-structure' is a near-surface structure. This is a level close to surface structure, subject to certain well-formedness conditions. It is also the input to the 'PF-component', which maps it onto a phonetic form (or 'surface' structure), and to the 'LF-component', which maps it onto a 'logical form', where certain aspects of meaning are made explicit.

These last two components will not be referred to in my discussion.

Seven theories (or sub-theories) are involved in this system. One of them is X-bar Theory, which defines some structural properties of D-structures. The others are: Control Theory, Binding Theory, Bounding Theory, Theta Theory, Case Theory, and Government Theory. Each of them is responsible for specific aspects of structure.

In the course of the thesis, I shall make no direct reference to Control or Binding Theory although I shall refer to the notions 'PRO' and 'pro' (two other types of empty category) in Chapters 3 and 4. I shall touch on Bounding Theory in Chapter 4, when I refer to the 'Subjacency' condition. Theta Theory will be briefly mentioned in Chapter 8. Also in Chapter 8, and in Chapter 9, Case Theory will be discussed in detail.

The central concept of GB is 'government', which is involved in a number of these sub-theories. Several definitions of government have been proposed but the most widely assumed is that of Aoun and Sportiche (1983: 214), paraphrased in (1.19).

(1.19) Government

A category  $x$  governs a category  $y$  if and only if  
 (i)  $x$  is  $X^0$   
 (ii)  $x$  and  $y$  are dominated by exactly the same maximal projections

As was mentioned earlier (p. 14),  $X^0$  stands for any lexical category. However, it is assumed (Chomsky 1981: 162; 1985: 162) that INFL is only a governor if it bears the feature complex AGR (i.e. when it appears in a finite clause) and that COMP is only a governor if it is a prepositional element like *for* in English -- the so-called 'prepositional' complementizer as in *They prayed for Tom to be saved*.

Government is particularly important in Case Theory since it is involved in the main Case marking conventions.<sup>7</sup> In English, nominative Case is assigned to an NP governed by INFL[+AGR] (i.e. to the subject in a finite clause). Objective Case is assigned to an NP governed by a verb with a Case-assigning property, a preposition, or a prepositional complementizer (i.e. to object, object of a preposition, and the subject of a non-finite clause). I shall be concerned with matters of Case assignment in Chapters 3, 4, 8, and 9, and with the precise formulation of the Case marking conventions in Chapters 8 and 9.

#### 1.5. Some remarks on Polish work on syntax

##### 1.5.1. The general approach

In the course of my discussion of Polish, I shall comment critically on Polish work in some of the areas with which I am concerned. Since the theoretical assumptions adopted in this thesis are not taken for granted by mainstream Polish syntacticians, one might question whether it is legitimate to evaluate their work from this position. In the present sub-section, I shall briefly characterize the position of Polish work on syntax, and in the next sub-section, I shall discuss one aspect of Polish linguists' analysis of PP's.

There appears to be enough common ground between the 'Polish approach' to syntactic investigation and the approach adopted here to make them comparable. This includes a conceptual background and a recognition of the merits of explicitness in linguistic analysis.

In the previous section, I introduced some basic concepts and terminology. Since most of them have their roots in traditional grammar and structural linguistics, corresponding notions can be found in Polish work. Thus, we find references to lexical categories (*części mowy* 'parts

of speech'), preposition (*przyimek*), constituent (*grupa* 'group'), phrase (*fraza*), head (*człon główny* 'main element' or *centrum* 'centre'), subcategorization (*rekcja* 'rection' or *konotacja* 'connotation'), complement (*dopełnienie*), object (*dopełnienie bliższe* 'closer complement'), and others.

In recent years, the need for explicitness in linguistic analysis has been strongly emphasized in two major works on Polish syntax: Topolińska 1984b, and Saloni and Świdziński 1985. The introductions to both books stress the need for 'using methods that are more precise and concise, which facilitate a verification and an evaluation of the proposed analyses' (Topolińska 1984b: 5),<sup>8</sup> and for a 'system of formal representation of syntactic structure ... in any methodological approach that claims a degree of order and discipline' (Saloni and Świdziński 1985: 9).<sup>9</sup> Equally forcefully, the authors distance themselves from 'traditional' grammar and show their readiness to revise 'traditional' analyses:

'The text presented to the reader differs from the well-known grammatical descriptions of literary Polish. The reason for this should be seen in the changes that have occurred in the course of the last sixty years or so, that is since the time when the last full synthesis was published in Stanisław Szober's (1923) textbook ...' (Topolińska 1984b: 5)<sup>10</sup>

'... the present textbook does not include a course in traditional grammar and it introduces unconventional terminology. In fact, it presupposes the student's familiarity with traditional, school grammar, especially where the traditional analyses are criticized and discussed' (Saloni and Świdziński 1985: 11)<sup>11</sup>

The similarities in these two areas make some of the material in the present thesis directly relevant to Polish work on Polish syntax. As it happens, the modern works have failed to point out the inadequacies of the traditional analyses of Polish prepositions and prepositional phrases.

What is not shared by the two approaches are the assumptions of X-bar Theory and the GB framework. Since, however, a constituent structure analysis is presupposed in much Polish recent work, incorporating an explicit version of X-bar Theory into it would appear not to pose any problems. GB, however, is further removed from Polish conceptions.

In Topolińska 1984b, the Extended Standard Theory -- the immediate predecessor of GB and the background of X-bar Theory -- is explicitly rejected in favour of a framework resembling early Generative Semantics, where underlying structures are equated with semantic representations (Karolak 1984: 19; Bobrowski 1985). Saloni and Świdziński, on the other hand, state (p. 10) that although they have, to some extent, drawn on the achievements of transformational generative grammar, they are not to be considered as its followers.

Transformational grammar has not, in fact, been popular with mainstream Polish linguists. For example, in a review of Chomsky 1965 in Pisarkowie 1966, it is asserted that the grammar outlined by Chomsky has a fundamental flaw in that the deep structure does not provide for free word order languages (1966: 239-240). Although Polish is not mentioned there by name, it is natural to suppose that the authors of the review have Polish in mind. Elsewhere, the transformational model of Chomsky 1957 is rejected as unsuitable for Polish without considerable modifications because of the rich inflectional system of Polish (Saloni and Świdziński 1985: 17-18). Presumably, such opinions together with some ill-founded scepticism about transformational grammar -- questioning the value of theoretical approach to the study of grammar more than the transformational model itself -- in, e.g. Mańczak 1967 and Heinz (1978: 373, 471), have contributed to a certain lack of interest

among Polish linguists in the subsequent developments of early transformational grammar.<sup>12</sup>

As is well-known, word order in Polish sentences depends on which elements carry 'given' and 'new' information relative to the conversation context in which they occur. Yet, in work concerned with the structure of information in a sentence, the SVO word order is regarded as basic (Szwedek 1974, Fisiak et al. 1978: 36-41, Grzegorek 1984: 91). Following Ross' (1967: 42) discussion of a similar phenomenon in Latin and Pesetsky's (1982: 117-118) in Russian, we can accommodate this feature of Polish by assuming that the permutations of the basic SVO pattern arise through 'scrambling' -- a reordering of elements within a clause applying after S-structure.

It should be noted that within a prepositional phrase, the order of elements is not free. As (1.20) illustrates, prepositions must be preceded by specifiers and followed by complements.

- (1.20) a. Adam mieszka tuż za rogiem.  
 Adam lives right around corner  
 'Adam lives right around the corner.'
- b. ? Adam mieszka za rogiem, tuż.  
 '? Adam lives around the corner, just.'
- c. \* Adam mieszka rogiem za.  
 '\* Adam lives the corner around.'

In this respect, Polish and English are alike.

The rich inflectional system poses no particular problems for a transformational analysis of Polish syntax. Although it entails complex case marking conventions and complex rules for subject-verb agreement, these complexities must be accommodated within any framework. Thus, there is no reason why Polish grammar should not be analyzed within a

transformational framework.

### 1.5.2. The status of Polish prepositions

While the view that prepositions are heads of phrases is fairly well established as far as English is concerned, it has not been accepted by mainstream Polish linguists working on Polish. My full case for adopting this view of Polish prepositions will emerge in the course of the discussion in Chapters 2, 5, and 6. Here, I shall present the alternative view and some general objections to it.

According to some Polish linguists, prepositions in Polish are members of a lexical category which determine the case of the associated NP and which are part of that NP (Grochowski 1984a: 255; Laskowski 1984a: 164). This might mean that the phrase *z kina* 'from the cinema(GEN)', for example, has the following representation:

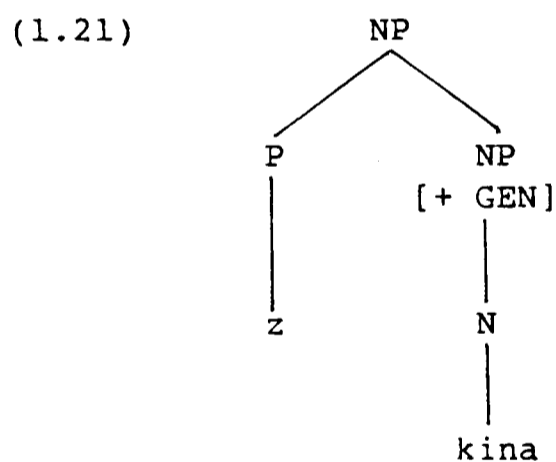

A more precise and elaborate statement is provided by Saloni and Świdziński (1985: 54-55, 215). They hold that prepositions form a lexical category and determine the case of the associated NP, with which they form an exocentric construction called a 'PNP' (*fraza przyimkowo-nominalna (PRNP)* 'preposition-nominal phrase'). Thus, the phrase *z kina* has the following structure:

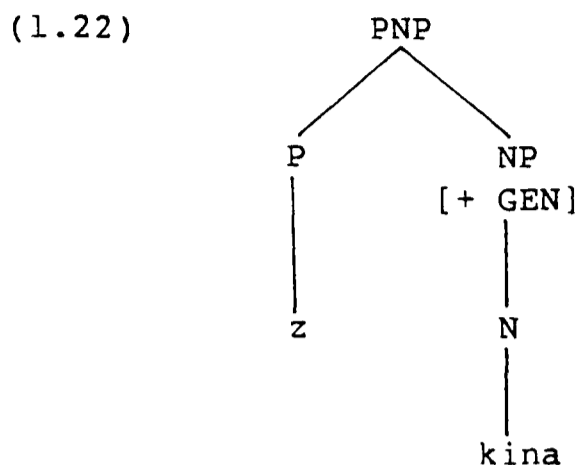

Either of these formulations is an advance on a previous approach, due to Kuryłowicz 1949 (as described in Karolak (1965: 145) and Jurkowski (1972: 23)), within which prepositions are part of discontinuous case markers and -- by implication -- not members of a lexical category. However, neither of the alternatives to this position is satisfactory either. Their common characteristic is that prepositions are not heads of phrases.

Let us, then, look more closely at two central features of heads (cf. pp. 15-16 above). One is that a head determines the identity of a phrase of which it is a constituent. Most linguists would agree that a phrase like *an old man* or its Polish counterpart *stary człowiek* is a 'noun phrase' because it contains a noun, and a phrase like *quite young* or its Polish counterpart *całkiem młody* is an 'adjective phrase' because it contains an adjective.

The second feature of heads is that they partially determine the internal structure of the phrase of which they are a constituent. For example, the verb *kick* in English requires an NP but not a clause as a complement (cf. *kick a ball* vs *\*kick that he'll walk again*), and the verb *hope* requires a clause but not an NP (cf. *hope that he'll walk again* vs *\*hope a ball*).

Polish prepositions have both these characteristics. The identity of a phrase is determined by a preposition in cases in which, for example, one verb requires a complement phrase with the preposition *na* 'on' rather than *o* 'for' (cf. *pozować na aktora* 'pose as an actor(ACC)' vs *\*pozować o aktora*) and another verb requires *o* rather than *na* (cf. *troszczyć się o aktora* 'care for an actor(ACC)' vs *\*troszczyć się na aktora*).

As for the other feature, Polish prepositions determine the internal structure of the phrase by determining the type of constituent they combine with and if it is an NP, they determine its case form.

Polish linguists would presumably accept both these points. In fact, Saloni and Świdziński -- who present their views more explicitly than others -- describe prepositions as having these properties and heads as having these characteristics.

The only reason why Saloni and Świdziński deny prepositions the status of a head is that the prepositional constituents of which they are a part cannot be reduced to the preposition itself (p.54). For example, *z kina* cannot be reduced to *z* (or to *kina*). Therefore, they conclude (p.55), such a constituent must be exocentric.

It is not clear what general criterion they are appealing to here. Either they claim that it must be possible for all members of a category to appear on their own for it to be a head, or they claim that only some members of a category must have this ability. If they assume the former, then they cannot regard Polish adjectives as heads because it is not possible for all of them to appear on their own (cf. *Tomek jest skłonny do żartów* 'Tomek is inclined to joke' vs *\*Tomek jest skłonny* 'Tomek is inclined'), and they cannot regard English verbs as heads because it is not possible for all of them to appear on their own (cf. *He's been*

eating vs *\*He's been devouring*).<sup>13</sup> If they assume the latter, then there is no basis for saying that Polish prepositions are not heads because -- as we shall see in the next chapter -- some prepositions can appear on their own.<sup>14</sup>

There is one other reason why one should be sceptical about the value of this criterion. It has the consequence that among non-heads (e.g. determiners and intensifiers), there is a class of items which have the central characteristics of heads. This is a problematic conclusion within any restrictive approach to syntactic analysis.

Given these considerations, I conclude that the view that prepositions are not heads in Polish is ill-founded.

## NOTES TO CHAPTER 1

1. Polish examples will usually be accompanied by an English gloss, containing -- if necessary -- relevant grammatical information, and by a translation. No acceptability judgements are associated with the glosses. Either the translation or the gloss will be omitted where the other seems sufficient for the interpretation of a given example. Both will be omitted where the interpretation can be reconstructed from a similar neighbouring example.
2. I assume below (Chapter 3, p. 66, Chapter 4, p. 117, and Chapter 6, p. 174) that relative clause constructions involve an  $\bar{X}$  with another  $\bar{X}$  as its head, and that coordinate constructions involve an  $X^n$  (i.e. an X with up to the maximal number of bars) with a number of  $X^n$ 's as heads (see in particular Chapter 9, p. 259).
3. This last option is only realized in English. In Polish, the COMP node must always be filled. See Chapter 6 (pp. 160-161) for illustration.
4. Chomsky 1981 considers the structure in (1.16) only in passing.
5. Among other prominent frameworks are Generalized Phrase Structure Grammar (Gazdar et al. 1985), Lexical Functional Grammar (Bresnan 1982b), and Relational Grammar (Johnson 1977). They are all non-transformational frameworks. The first two assume the X-bar Theory of syntactic categories.
6. Chomsky 1985, following Pesetsky 1982, suggests that lexical entries need not include statements about subcategorization properties because these properties are predictable from other factors. I shall comment on this position in Chapter 10, Section 10.4.
7. Following the established convention (Chomsky 1981: 2, 16 n.1), I shall use 'Case' with a capital 'C' in the technical sense of Case Theory. Referring to ordinary case marking, I shall use 'case' with a small 'c' or -- in contexts where confusion might arise -- I shall use the phrases 'case form' and 'morphological case'.
8. Longer quotations from the Polish literature will be given in English in my own translation in the main body of the text and their original versions will appear in notes.

[*świadoma ambicja*] używania metod bardziej precyzyjnych, ścisłych, takich, które pozwalają sprawdzić i ocenić poprawność proponowanych ujęć (Topolińska 1984b: 5)

9. [*Jednak operowanie*] jakimś sposobem reprezentacji formalnej struktury składniowej jednostek wypowiedzeniowych [*jest konieczne*] przy każdym podejściu metodologicznym roszczącym sobie pretensje do pewnego stopnia porządku i dyscypliny. (Saloni and Świdziński 1985: 9)

10. *Tekst, który oddajemy w ręce czytelników, różni się od znanych opisów gramatycznych literackiej polszczyzny. Przyczyn tego szukać należy w zmianach, jakie zaszły w ciągu ostatnich sześćdziesięciu paru lat, tj. od momentu, w którym dokonano ostatniej pełnej syntezy, utrwalonej w [używanym do dziś na studiach polonistycznych] podręczniku Stanisława Szobera (1923 r.).* (Topolińska 1984b: 5)
11. *... skrypt nie referuje w zasadzie kursu składni tradycyjnej i wprowadza odmienny aparat pojęciowy, a jednak faktycznie -- choćby przez krytykę ujęć tradycyjnych i dyskusję z nimi -- zakłada u studenta dobrą znajomość kursu gramatyki ze szkół niższego stopnia* (Saloni and Świdziński 1985: 11)
12. This impression seems to be confirmed by the proceedings from a 1979 conference on 'The concepts of derivation in linguistics', organized at the Institute of the Polish Language at Lublin University (UMSC). Out of ten papers presented there, one is an up-to-date (1979) survey of the evolution of the concept of syntactic derivation in transformational grammar (Nowakowska 1981). Only this one paper is not followed by a transcript of discussion.
13. The strong form of the principle holds for Polish verbs as heads only if utterances like (i)B are considered as legitimate examples of verbs appearing on their own.

(i) A: Nie jestem pewien, czy Piotr przekona  
 not I-am sure whether Piotr will-convince  
 ją do małżeństwa.  
 her to marriage  
 'I'm not sure if Piotr will talk her into marriage.'  
 B: Przekona.  
 'He will.'

Such 'reductions' of verb phrases to verbs alone are possible in specific linguistic contexts but not as meaningful utterances in their own right (cf. Polański 1966: 87).

But if verbs in such contexts count as heads, then prepositions should also because they too can appear on their own in similar circumstances:

(ii) Kazałem, by usiedli przy stole, a nie na.  
 I-told that they-sat at table and not on  
 'I told them to sit at the table, not on the table.'

(iii) A: Czy wypadek zdarzył się przed koncertem?  
 whether accident happened PRT before concert  
 'Did the accident happen before the concert?'  
 B: Nie, po.  
 'No, after.'

14. It is worth noting that not even the weaker form of the criterion is accepted within the GB framework, in which INFL and COMP are regarded as heads of S and S, respectively, (cf. pp. 17-18 above). Neither S nor S can be reduced to these elements.

## CHAPTER 2

### INTRANSITIVE PREPOSITIONS

#### 2.1. Introduction

In Chapters 3 and 6, I shall invoke the notion 'intransitive preposition', which refers to prepositions not followed by a complement. In view of the fact that in some grammatical work, especially descriptions of Polish, they are regarded as 'adverbs' or ('pronouns'), it is appropriate at this point to consider the evidence for intransitive prepositions in both English and Polish, and to exclude the possibility that the items in question are adverbs (or pronouns). Henceforth, I shall use the term 'prepositional adverbs' from Quirk *et al.* (1985: 662) as a neutral term of reference for them, without adopting their view that they really are adverbs.

In recognizing a class of intransitive prepositions, one rejects traditional definitions of the category 'preposition'. Huddleston (1984: 91) cites Curme's (1935) definition as representative of the tradition. According to Curme, a preposition is 'a word that indicates a relation between the noun or pronoun it governs and another word, which may be a verb, an adjective, or another noun or pronoun' (1935: 87). A similar definition is adopted in contemporary Polish work on Polish. Saloni and Świdziński, for example, define prepositions as 'a class of uninflected items, whose unique form cannot appear on its own, has a relating function, and requires a specific case value' (1985: 95).<sup>1</sup>

As we can see, according to both definitions, prepositions must take a complement. In Curme's definition, the complement is explicitly said to be of the category NP. In Saloni and Świdziński's definition, this restriction is implied by reference to case requirement.<sup>2</sup> The discussion in the present chapter will question the validity of such definitions.

The chapter is organized as follows. In Section 2.2, I present some previous arguments for distinguishing intransitive prepositions in English and examine some additional data supporting the argument. In Section 2.3, I examine Polish data. Section 2.4 contains some concluding remarks.

## 2.2. Intransitive prepositions in English

The notion 'intransitive preposition' has been developed on the basis of theoretical as well as empirical considerations. Jespersen's (1924) argument, echoed in Emonds (1972: 547) and Jackendoff (1973: 346), is of the former type.

Jespersen seeks to establish a greater regularity in the system of parts of speech by drawing parallels between verbs and certain 'particles', which include prepositional adverbs.<sup>3</sup> He suggests (p. 88) that just as verbs like *sing* in his examples in (2.1) below can be 'incomplete' (i.e. 'transitive') and 'complete' (i.e. 'intransitive'),

(2.1) a. He *sings* a song.

b. He *sings*.

so should prepositions be classified in these terms, given that items like *in* and *before* can occur both with and without a complement. His examples in (2.2) and (2.3) illustrate.<sup>4</sup>

(2.2) a. He was *in the house*.

b. He was *in*.

(2.3) a. He had been there *before breakfast*.

b. He had been there *before*.

What seems to be tacitly assumed in Jespersen's argument has been made explicit by Emonds (p. 547) and repeated by Jackendoff (p. 346). This is that the morphological identity and semantic similarity between the preposition *in* or *before* and the prepositional adverb *in* or *before* suggests that one may be missing a generalization by placing these and similar items in two separate word classes. It looks, then, as if we should say, as Emonds (p. 548) and Jackendoff (p. 348) do, that some prepositions (e.g. *with*, *at*, and *for*) subcategorize for an obligatory NP complement, some (e.g. *before*, *down*, and *around*) subcategorize for an optional complement, and that certain other items with the same distribution as ordinary PP's (e.g. *apart*, *beforehand*, and *away*) are prepositions that subcategorize for no complement. This gives us the following lexical entries for the three types of prepositions:

(2.4) a.  $\left[ \begin{array}{l} \textit{with} \\ [-N, -V] \\ + [\_ \bar{N}] \end{array} \right]$     b.  $\left[ \begin{array}{l} \textit{in} \\ [-N, -V] \\ + [\_ (\bar{N})] \end{array} \right]$     c.  $\left[ \begin{array}{l} \textit{apart} \\ [-N, -V] \\ + [\_] \end{array} \right]$

This proposal is quite plausible. It should, however, be supported by empirical considerations. We can do this by a comparison of the distributional properties of prepositional adverbs with prototypical, 'ordinary' PP's on the one hand and with prototypical ADVP's on the other. By a 'prototypical' PP, I mean a PP consisting of a preposition and its NP complement, and by a 'prototypical' ADVP, I mean an ADVP

headed by a central member of the category 'adverb' -- an item related to an adjective with, in English, a *-ly* suffix. If it can be shown that prepositional adverbs have the same distribution as PP's but not as ADVP's, then it can be claimed that they are prepositions and not adverbs.

It follows that the fact that prepositional adverbs can appear in the adverbial position does not have any bearing on the question of their category status because, as illustrated in (2.5), both PP's and ADVP's can appear in that position.<sup>5</sup>

(2.5) Peter read the minutes  $\left\{ \begin{array}{l} \textit{beforehand.} \\ \textit{at lunch.} \\ \textit{previously.} \end{array} \right.$

Four constructions in which prepositional adverbs have the same distribution as PP's have been considered by Emonds (pp. 550-554) in his argument for intransitive prepositions. Here, I shall cite only one of them and then consider two other constructions that have not previously been considered.<sup>6</sup>

Emonds notes (pp. 551-553) that the intensifier *right* can appear as a modifier in PP's but not in other categories. In particular, we should say, it can modify a spatial or a temporal PP but not a spatial or a temporal ADVP. In (2.6), I provide my own illustrations of this point to ensure uniformity with subsequent examples.

(2.6) a. The article was printed *right*  $\left\{ \begin{array}{l} \textit{on time.} \\ \textit{in the middle of the page.} \end{array} \right.$

b. The article was printed *right*  $\left\{ \begin{array}{l} \textit{after.} \\ \textit{below.} \end{array} \right.$



Although a PP headed by an intransitive preposition does not contain a complement, it can contain a specifier such as *right* in (2.6b) above or *straight* as in *The ship went straight down*. Since specifiers are sisters of  $\bar{X}$ 's (cf. Chapter 1, pp. 15-16 above), a PP headed by an intransitive preposition has a full  $\bar{X}$  structure:

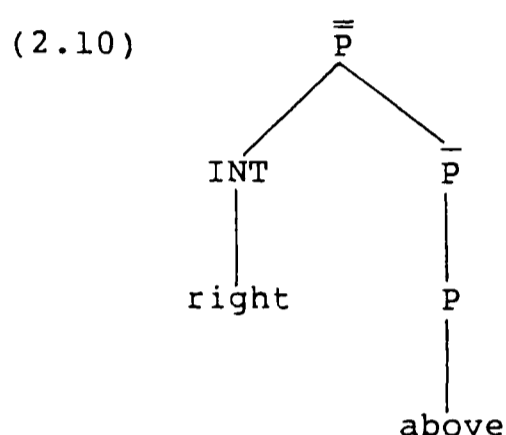

We shall see in the next section that this is also appropriate for Polish.

### 2.3. Intransitive prepositions in Polish

I shall now argue that certain Polish preposition-like items which appear without a complement should be regarded as intransitive prepositions, and then I shall examine the category status of spatial and temporal pro-forms such as *tam* 'there' and *potem* 'afterwards', which do not take a complement but can, nevertheless, be shown to be (intransitive) prepositions.

As in my discussion of English prepositional adverbs, I shall compare the distributional properties of Polish prepositional adverbs with prototypical PP's and prototypical ADVP's. The latter, in Polish, are phrases headed by forms related to adjectives, ending in -o or -e such as, for example, *daleko* 'far' and *wczesnie* 'early', whose related adjectives are, respectively, *daleki* 'far' and *wczesny* 'early'. Since, however, PP's in Polish overlap in their distribution with both ADVP's

and prepositional adverbs in the counterparts of the last two constructions considered in the previous section, the data are not quite the same.

(2.11)-(2.14) contain examples of the first type of prepositional adverbs.

(2.11) a. *Autobus zatrzymał się obok dworca.*

bus stopped PRT by station(GEN)

b. *Autobus zatrzymał się obok.*

(2.12) a. *Bank zbudowano naprzeciw muzeum.*

bank was-built opposite museum(GEN)

b. *Bank zbudowano naprzeciw.*

(2.13) a. *Wokół domu chodziły kaczki.*

around house(GEN) walked ducks

b. *Wokół chodziły kaczki.*

(2.14) a. *Wewnątrz domu było pełno dymu.*

inside house(GEN) was much smoke

b. *Wewnątrz było pełno dymu.*

The items in question are standardly classified as 'prepositions' when followed by an NP in sentences like (2.11a)-(2.14a), but when not followed by a complement, as in (2.11b)-(2.14b), they are 'adverbs' (*przysłówki*; cf. Sambor 1971: 126-128; Grzegorzczkova 1975: 116) or 'particle-adverbs' (*partykuło-przysłówki*; cf. Grochowski 1984a: 259; Saloni and Świdziński 1985: 95-97, 115).<sup>8</sup> According to Wątor (1969: 373), what I describe as prepositional adverbs are regarded as prepositions used as adverbs. According to Klemensiewicz (1937: 67), the

items in question in (2.11a)-(2.14a) are 'defective prepositions' (*przymyki niewłaściwe*), which are adverbs when they appear on their own.

The multiple classification of these items as prepositions and as adverbs resembles the traditional classification of similar items in English. In response to this classification, we can recall Jespersen's comparison between 'incomplete' and 'complete' verbs and 'incomplete' and 'complete' prepositions (cf. pp. 34-35 above). As illustrated in (2.15), Polish also has verbs of both types and so Jespersen's case for intransitive prepositions based on this comparison is equally plausible for Polish.

(2.15) a. Zespół *zaśpiewał* *piosenkę*.

band sang song

b. Zespół *zaśpiewał*.

As far as I am aware, Polish data have not been considered in the light of this argument. It is my task, then, to assess the viability of this argument for Polish by considering the empirical evidence for analyzing *obok*, etc. in (2.11b)-(2.14b) as intransitive prepositions.

We look first at a subjectless predicative construction such as in (2.16).<sup>9</sup>

(2.16) Dziadkowi było *blisko do dworca*.

granddad(DAT) it-was near to station

'It was close to the station for granddad.'

This contains an experiencer NP in the dative case and a predicative ADVP. (2.17) illustrates that neither the prepositional adverbs nor the corresponding PP's from (2.11)-(2.14) can appear as predicates in this construction.<sup>10</sup>

- (2.17) \* Dziadkowi było {  
*obok (dworca).*  
*naprzeciw (muzeum).*  
*wokół (domu).*  
*wewnątrz (domu).*

Here, then, we have one example of a contrast between prepositional adverbs and PP's on the one hand, and ADVP's on the other.

We turn next to a construction with the verb *wyglądać* 'look' in the sense of 'seem' or 'appear to be'. As illustrated in (2.18), an ADVP can appear in its complement.

- (2.18) Stąd        te        drzewa wyglądały *bardzo daleko.*  
 from-here these trees looked        very        far

However, neither a PP nor a prepositional adverb can appear in this position:

- (2.19) \* Stąd te drzewa wyglądały {  
*obok (dworca).*  
*naprzeciw (muzeum).*  
*wokół (domu).*  
*wewnątrz (domu).*

Finally, we consider the intensifier *tuż*. Like *right* in English, it can modify PP's and prepositional adverbs but not equivalent ADVP's. The examples in (2.20) illustrate that *tuż* cannot co-occur with ADVP's.

- (2.20) a. \* Adam mieszka *tuż blisko.*  
 Adam lives        right near
- b. \* Wypadek zdarzył się *tuż poprzednio.*  
 accident happened PRT right previously

The examples in (2.21) illustrate that *tuż* can modify PP's and prepositional adverbs.

(2.21) a. *Autobus zatrzymał się tuż obok (dworca).*

bus stopped PRT right by station

b. *Bank zbudowano tuż naprzeciw (muzeum).*

bank was-built right opposite museum

c. *Tuż wokół (garażu) chodziły kaczki.*

right around garage walked ducks

d. *Tuż wewnątrz (domu) było pełno dymu.*

right inside house was much smoke

It turns out, then, that not only a general comparison between verbs and prepositions but also the distributional properties of prepositional adverbs suggest that they should be analyzed as intransitive prepositions.

These intransitive prepositions differ from other spatial prepositions, such as *przed* 'in front of', *koło* 'by', *za* 'behind', etc. when they appear without a complement. These prepositions can appear on their own only in a specific linguistic context, as was briefly pointed out in note 13 to the previous chapter (p. 31). In (2.22), I give another example of these prepositions appearing without a complement in the following exchange between speakers:

(2.22) A: *Mam postawić ten wazon koło stołu czy na?*

have-I put this vase by table or on

'Shall I put this vase by the table or on the table?'

B: *Postaw koło.*

put by

Intransitive prepositions can also appear in such contexts, as the following example illustrates:

(2.23) A: Posadzić te warzywa obok szklarni czy wewnątrz?

plant these vegetables by greenhouse or inside

'Shall I plant these vegetables by the greenhouse  
or inside?'

B: Posadź wewnątrz.

plant inside

Apart from this, however, intransitive prepositions can appear without a specific preceding discourse. Thus, there is a clear contrast in acceptability in the following examples with intransitive prepositions (similar to the examples in (2.11b)-(2.14b)) and with transitive prepositions with no complement:

(2.24) a. *Obok* }  
*Naprzeciw* } wybudowali nam lotnisko.  
 \* *Koło* }

by }  
 opposite } they-built us airport  
 by }

b. *Wokół* } mieliśmy piękny widok.  
 \* *Nad* }

around } we-had beautiful view  
 over }

c. *Wewnątrz* } było całkiem ciepło.  
 \* *W* }

inside } was quite warm  
 in }

Given this contrast, it is appropriate not to regard the occurrences of prepositions like *koło* in special contexts like (2.22) as instances of intransitive prepositions.

While *obok* 'by', etc. are prepositions that can be transitive or intransitive, certain other items are intransitive only. These are spatial and temporal adverbial pro-forms, exemplified in (2.25).<sup>11</sup>

(2.25) a. Adam mieszka { *tu(tutaj)*.  
                                  { *tam*.

Adam lives { here  
                                  { there

'Adam lives here/there.'

b. Samolot przeleciał { *tędy*.  
                                  { *tamtędy*.

airplane flew { through-here  
                                  { through-there

'An airplane flew this way/that way.'

c. Przekopali trawnik { *odtąd*.  
                                  { *dotąd*.

they-dug lawn { from-here  
                                  { to-here

'They dug the lawn from here/to here.'

d. *Stąd* } mieli piękny widok na morze.  
      *Stamtąd* }

from-here } they-had beautiful view on sea  
from-there }

'From here/from there, they had a beautiful view  
of the sea.'

e. Anna  $\left. \begin{array}{l} \textit{wtedy} \\ \textit{przedtem} \\ \textit{potem} \end{array} \right\}$  przeczytała gazetę.

Anna  $\left. \begin{array}{l} \textit{then} \\ \textit{beforehand} \\ \textit{afterwards} \end{array} \right\}$  read newspaper

'Anna read the newspaper then/beforehand/afterwards.'

f.  $\left. \begin{array}{l} \textit{Odtąd} \\ \textit{Dotąd} \end{array} \right\}$  praca była dla niej koszmarem.

$\left. \begin{array}{l} \textit{since-then} \\ \textit{until-then} \end{array} \right\}$  work was for her nightmare

'Since then/until then, work was a nightmare to her.'

In the Polish literature, these items are associated with the category 'adverb' or 'pronoun'. Grzegorzczkova (1975: 111) regards them as 'adverbial pronouns' (*zaimki przysłówkowe*), and Laskowski (1984b: 37) and Grochowski (1984b: 90) label them simply 'adverbs' (*przysłówki*). According to Szober (1923: 103) and Jodłowski (1976: 19, 24), they are 'adverbial demonstrative pronouns' (*zaimki przysłowne wskazujące*), and according to Klemensiewicz (1969: 12), they are 'uninflected demonstrative pronouns' (*nieodmienne zaimki wskazujące*). Finally, for Saloni and Świdziński (1985: 97), they are 'particle-adverbs' (*partykuło-przysłówki*; cf. my note 8 to this chapter). In Jaworska (1984: 272), I assumed without argument that they were adverbs.

I shall now show that they are neither adverbs nor pronouns, but that they are prepositions. The three types of data considered in connection with *obok*, etc. will be considered again in an argument against these pro-forms being adverbs. After that, I shall argue that they are not pronouns.



which makes them like PP's and unlike ADVP's.

- (2.27) a. \* Dziadkowi było  $\left\{ \begin{array}{l} tu/tam. \\ odtąd/dotąd. \\ tędy/tamtędy. \end{array} \right.$
- granddad(DAT) was  $\left\{ \begin{array}{l} here/there \\ from-here/from-there \\ through-here/through-there \end{array} \right.$

- b. \* Z tego miejsca te drzewa  
from this place these trees

- wyglądały  $\left\{ \begin{array}{l} tu/tam. \\ odtąd/dotąd. \\ tędy/tamtędy. \end{array} \right.$
- looked  $\left\{ \begin{array}{l} here/there \\ from-here/from-there \\ through-here/through-there \end{array} \right.$

We can see from these data that where ADVP's and PP's differ in their distribution, the pro-forms resemble PP's and not ADVP's. Thus, it is natural to conclude that they are prepositions and not adverbs. Before we can fully accept this conclusion, however, we must show that they are not pronouns.

The most straightforward evidence against the idea that they are pronouns is provided by the fact that a subset of them can appear in positions where ordinary NP's cannot appear. For example, the verbs *mieszkać* 'live' in the sense of 'dwell', *włożyć* 'put', and *wyjąć* 'take out' subcategorize for a spatial complement which can be a PP but not an NP. It can also be a pro-form. The following examples illustrate:<sup>14</sup>

(2.28) a. Ten pan mieszka { *w hotelu.*  
 \* *hotelem.*  
*tutaj/tam.*

this man lives { in hotel  
 hotel(INST)  
 here/there

b. Włóż to { *do biurka.*  
 \* *biurkiem.*  
*tu/tam.*

put this { into desk  
 desk(INST)  
 here/there

c. Babcia wyjęła prezenty { *z szuflady.*  
*szufladą.*  
*stąd/stamtąd.*

granny took-out presents { from drawer.  
 drawer(INST)  
 from-here/from-there

As the pro-forms differ from NP's here in their distribution, we can conclude that they are not pronouns. Since they have the same distribution as PP's here as well as in the examples with adverbs considered above, they are prepositions.

It is worth noting that Jackendoff (1977: 79; 1983: 49) regards the English demonstratives *here*, *there*, *now*, and *then* as intransitive prepositions. However, it has rather convincingly been argued by Larson (1985: 611-612) that they, and their *wh*-counterparts *where* and *when* have certain properties which are only characteristic of NP's in English and

hence that they should be analyzed as pronouns. It appears, then, that English has no demonstrative intransitive prepositions.

#### 2.4. Conclusion

In the present chapter, I have investigated the case for recognizing a sub-category 'intransitive preposition' -- analogous to the sub-category 'intransitive verb' -- which includes certain lexical items traditionally classified as adverbs (or pronouns). In comparing the distribution of these items with the distribution of PP's and ADVP's (and NP's in the case of Polish demonstratives), I hope to have demonstrated that this position is well-motivated both for English and for Polish. Among intransitive prepositions, there are items that can take an NP complement (e.g. *in* and *obok* 'by') and items that cannot take a complement (e.g. *beforehand* and *stąd* 'from-here'). The latter type in Polish involves a class of spatial and temporal demonstratives. I shall return to them in Chapter 6.

The recognition of intransitive prepositions extends the membership of the category 'preposition' but it reduces the heterogeneity of the category 'adverb' (or 'particle-adverb'). It also undermines traditional definitions of prepositions (cf. pp. 33-34 above) while allowing a more adequate classification of the items in question, given their distributional properties.

Another point to note is that the fact that Polish PP's can appear in positions in which NP's cannot appear (e.g. as a complement of the verb *mieszkać* 'dwell') provides further evidence against analyzing PP's as NP's with a non-head preposition (cf. Chapter 1, p. 26 above). Within such an analysis, one would have to distinguish between NP's with and without prepositions to account for their distribution. This would be unusual since, in general, NP's with quite different internal structures

have the same distribution. Within an approach in which prepositions are heads of phrases, the type of constituent is identified in a unique way.

Finally, it should be mentioned that phrases like *obok dworca* 'by the station', etc., which can be reduced to the preposition alone, provide motivation for analyzing prepositions as heads according to Saloni and Świdziński's (1985) criterion discussed in the previous chapter (cf. pp. 28-29 above).

## NOTES TO CHAPTER 2

1. [*Przyimki to*]klasa leksemów nieodmiennych, których jedyna forma nie jest używana samodzielnie, ma funkcję łączącą i wymaga określonej wartości przypadkowej. (Saloni and Świdziński 1985: 95)
2. In fact, their restriction is not as strong as Curme's because they describe a predicative construction like (i),

(i) Uważam            ciebie za dobrą.  
       I-consider you    as good(ACC)  
       'I consider you good.'                               (= S&Ś's (24c), p. 158)

as involving a preposition (*za*) followed by an adjectival complement (*dobrą*). The case form of the adjective clearly depends on the preposition. Thus, apart from the preposition-nominal phrase (cf. p. 26 above), the authors recognize (p. 215) a 'preposition-adjectival' phrase (*fraza przyimkowo-przymiotnikowa*). Given this qualification, they see prepositions as taking complements of those syntactic categories with which case can be associated. In Chapter 8 (pp. 231-233), I briefly discuss the type of construction in (i).

3. For Jespersen (1924: 91), 'particles' are words that cannot be classified as nouns, adjectives, pronouns, or verbs. Apart from prepositions, this class includes adverbs, coordinating and subordinating conjunctions, and interjections. In Chapter 4 (pp. 103-105), I consider Jespersen's views on the relation between prepositions and subordinating conjunctions.
4. The terms 'transitive' and 'intransitive' preposition refer to prepositions that do and do not take a complement, respectively. The term 'transitive' verb is usually applied to those verbs that take a complement and have participial forms that appear in passive constructions. Thus, 'transitive' verbs are only a subset of verbs that can take a complement. Jespersen's term 'incomplete' verbs seems to be appropriate for all complement-taking verbs. See Chapter 8 (pp. 237-239) for a proposal for the formal representation of transitive and intransitive verbs and prepositions within the GB framework.
5. As Quirk *et al.* (1985: 49) note, it is important to distinguish between the category 'adverbial' and the category 'adverb'. (The Polish counterparts of these terms are, respectively, *okolicznik* and *przysłówek*.) The former is a functional category like 'subject' (*podmiot*), 'object' (*dopełnienie*), etc., and the latter is a lexical category of the same type as 'noun' (*rzeczownik*), 'verb' (*czasownik*), etc. Some definitions of syntactic categories imply that only adverbs can function as adverbials.

6. All Emonds' arguments are repeated by Jackendoff (1973: 345-348).
7. I am grateful to Mr. T.F. Hoad for providing me with the example in (2.9).
8. According to Saloni (1974: 100), and Saloni and Świdziński (1985: 95, 97), the class of 'particle-adverbs' is a heterogenous set of items which do not meet the criteria for any other lexical category, including prepositions and adjective-related adverbs. It resembles somewhat Jespersen's class of 'particles' (cf. note 3 to this chapter). In my argument below, the fact that prepositional adverbs do not pattern with prototypical ADVP's is not of any consequence for this position. However, the fact that prepositional adverbs have the same distribution as prototypical PP's argues that they should not be regarded as members of an unrelated category with unpredictable properties.
9. I regard *blisko* 'near' as an adverb which is exceptional in that it can take an NP complement, e.g.:

- (i) a. Anna mieszka *blisko szpitala*.  
       Anna lives near hospital(GEN)  
       b. Anna mieszka *blisko*.

Unlike the prepositions in (2.11a)-(2.14a), *blisko* has an adjectival counterpart, *bliski* 'near', and it has the comparative and the superlative forms:

- (ii) Anna mieszka { *bliżej* } szpitala.  
                       { *najbliżej* }  
       Anna lives { nearer } hospital  
                    { nearest }

Unlike prepositions, *blisko* appears to lend itself to 'stranding' in *wh*-questions, e.g.,

- (iii) Którego szpitala Anna { \* *obok* } mieszka?  
                                   { *blisko* }  
       which hospital Anna { by } lives  
                                   { near }

and it can be separated from its complement in stylistically marked sentences like (iv).

- (iv) Anna { \* *obok* } mieszka szpitala.  
               { *blisko* }

It has been argued by Maling 1983 that *near* in English, which is comparable to *blisko* in its morphology and complement-taking possibilities (*blisko* can also take a PP complement), is an adjective which exceptionally takes an NP complement. McCawley (1985: 854-855) disputes this, claiming that *near* is a preposition at least when it takes an NP.

Even if *blisko* in combination with NP were a preposition with adverb-like features, it seems that it would still be appropriate to regard it as an adverb in the other contexts. In my examples in this section, I use *blisko* without an NP complement to avoid possible confusion. In the example in (2.16), *blisko* can be replaced by *daleko* 'far', which does not take an NP complement, and which might be considered a clearer example of an adverb.

10. In accordance with standard practice, in (2.17) and throughout the thesis, optional elements in example sentences are marked off by parentheses.

All three categories, ADVP's, PP's, and prepositional adverbs can occur as predicates with *być* in non-subjectless sentences, e.g.:

- |              |   |                             |
|--------------|---|-----------------------------|
| (i) Bank był | { | <i>dalej</i> .              |
|              | { | <i>naprzeciw (muzeum)</i> . |
| bank was     | { | further                     |
|              | { | opposite museum             |

This construction, then, does not provide any evidence for the category status of prepositional adverbs.

11. I presented some of the arguments for this analysis, in conjunction with the analysis of Polish complex adverbial constructions in Chapter 6, in a paper entitled 'The syntactic structure of certain complex adverbial constructions in Polish' read at the Slavonic Linguistics Seminar VI at Sheffield, 17-18 September, 1984.
12. Combinations of *tuż* with *tam* 'there', *tamtędy* 'through-there', and *stamtąd* 'from-there' appear to be less acceptable. This is probably a consequence of a semantic clash between *tuż*, which contains the element *tu* 'here', and *tam*, *tamtędy* and *stamtąd*, which contain the antonym of *tu* -- *tam*. Thus, the non-occurrence of *tuż tam*, etc. does not cast any doubt on this argument. Notice that *tuż* cannot modify ADVP's that do not conflict with its semantics, e.g. \**tuż blisko* 'right near' and \**tuż następnie* 'right next'.
13. The following examples show that all three types of temporal expression -- ADVP, PP, and prepositional adverb -- are excluded from these positions:

- |                 |      |   |                        |
|-----------------|------|---|------------------------|
| (i) * Dziadkowi | było | { | <i>wcześniej</i> .     |
|                 |      | { | <i>przed obiadem</i> . |
|                 |      | { | <i>przedtem</i> .      |
| granddad(DAT)   | was  | { | earlier                |
|                 |      | { | before dinner          |
|                 |      | { | beforehand             |

- (ii) \* Obiad wyglądał { później niż zwykle.  
                                   { po Dzienniku.  
                                   { potem.  
                                   { later than usual  
                                   { after the News  
                                   { afterwards

These data do not provide any evidence for the category status of the proforms.

14. I give examples of NP's in the instrumental case as this is the usual case for 'adverbial' NP's in Polish. (See Chapter 9, pp. 254-261, for the meaning of the term and an analysis of such NP's within the GB framework).

An apparent counter-example to this argument is a sentence like (i), where *mieszkać* 'live' is followed by an NP.

- (i) Ten pan mieszka kątem.  
       this man lives corner(INST)  
       'This man's got a shelter somewhere.'

It is not a real counter-example, however. As the English translation indicates, *mieszkać kątem* is an idiomatic expression in which *kątem* is not a spatial complement. *Kątem* could not be an antecedent of *tu* 'here' or *tam* 'there'.

## CHAPTER 3

### THE P-P-NP STRINGS IN ENGLISH

#### 3.1. Introduction

In this and the next three chapters, I shall be concerned with some fairly basic aspects of the structure of PP's in English and Polish. At the centre of my discussion is the claim made by Jackendoff 1973, 1977 that not only NP but also PP and  $\bar{S}$  can occur as the complement of a preposition. These chapters are mainly 'descriptive', that is, they make relatively little reference to theoretical issues.

In the present chapter, I shall examine what structures are formed by sequences of two prepositions and an NP in English. I shall refer to them as the P-P-NP strings. There has been some previous discussion of this topic but, in my view, it is fairly unsystematic and not entirely adequate. My main aim here then is to furnish a better-motivated and more adequate description of the data. To make the discussion manageable, I shall limit the range of the P-P-NP strings to that considered by Jackendoff and his critics.

Having, among other things, reaffirmed that among PP's are some in which a preposition is followed by a PP complement (i.e. that they have the P-PP structure), I shall note that two theoretical proposals that bear on the distribution of PP's are untenable. One is Hoekstra's (1984) Unlike Category Condition, and the other is Stowell's (1981) Case Resistance Principle. The P-PP structure will be referred to again in

## Chapter 7.

The discussion in this chapter is organized as follows. In Section 3.2, I summarize Jackendoff's (1973) original proposal and outline its revision. In Section 3.3, I re-examine his data in the light of the arguments of his critics and arguments of my own. I establish that four structures, not just two -- as Jackendoff claims -- must be associated with the six P-P-NP strings under consideration. In Section 3.4, I consider the theoretical implications of the P-PP structure. In the final section, I sum up the discussion and present a table listing the syntactic tests applied to the six P-P-NP strings at various stages of the discussion and the results of the tests.

### 3.2. Jackendoff's proposal

#### 3.2.1. A summary

The following are examples from Jackendoff's article, which form the basis for my discussion:<sup>1</sup>

- (3.1) The nine black riders appeared *out of the night*. (= J's (13a))
- (3.2) A great howl of pain emerged *from inside the rain barrel*.  
(= J's (12c))
- (3.3) Sam disappeared *down into the darkness*. (= J's (12b))
- (3.4) Chico raced *away from Mrs Claypool*. (= J's (16a))
- (3.5) The kite went *up into the cloud*. (= J's (20a))
- (3.6) Otis T. Flywheel raced *away in a battered Ford*. (= J's (16b))

The weakness of Jackendoff's article, as I shall demonstrate below, lies in its brevity and rather superficial argumentation. He contends that all of the above P-P-NP strings have either (3.7) or (3.8), or both as their structure. For the purpose of exposition, I quote these structures here in the form that Jackendoff presents them but in later

discussion I shall re-cast them in the X-bar Theory notation.

(3.7)

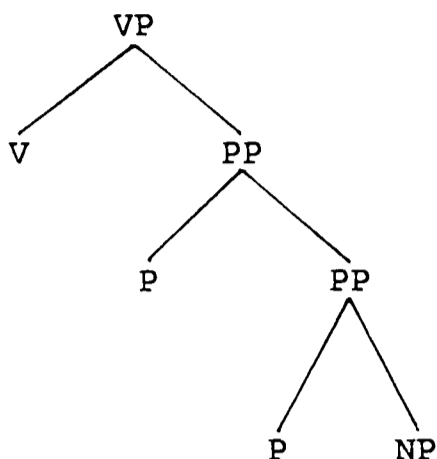

(= J's (15a))

(3.8)

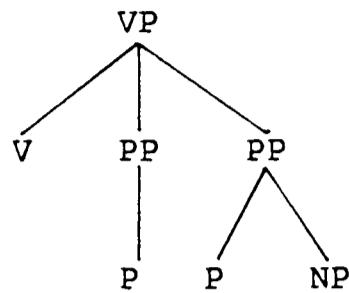

(= J's (15b))

In (3.7), we have a single PP, a constituent composed of a preposition and a PP complement. This structure, according to Jackendoff (p. 348), is associated with the strings in (3.1)-(3.4). In (3.8), we have two separate constituents. One is a PP containing only an intransitive preposition, and the other is an 'ordinary' PP containing a preposition and an NP complement. This structure, according to Jackendoff (p. 349), is appropriate for the string in (3.6). Finally, the string in (3.5) is said (pp. 349-350) to be ambiguous between (3.7) and (3.8), i.e., it can have either as its structure.

Jackendoff's motivation for these analyses is based on the following three tests: (i) preposing of the whole P-P-NP string, (ii) preposing of the first preposition, and (iii) insertion of a lexical item between the two prepositions. Jackendoff applies these tests to only one of the strings given in (3.1)-(3.4) above, that in (3.4), and to the strings in (3.5) and (3.6). In (3.9), I present the first set of the data with Jackendoff's acceptability judgements.<sup>2</sup>

(3.9) a. *Away from Mrs Claypool* raced Chico! (= J's (17a))

b. ?\* *Away* raced Chico *from Mrs Claypool*! (= J's (18a))

c. ?\* Chico raced *away quickly from Mrs Claypool*. (= J's (19a))

Since the whole string here can be preposed, and since prepositions cannot be separated from each other, Jackendoff concludes that *away from Mrs Claypool* forms a constituent of the form in (3.7), and implies (p. 348) that the strings in (3.1)-(3.3) do also.

Applied to the P-P-NP string in (3.6), the tests, according to Jackendoff, give the following results:

- (3.10) a. ?\* *Away in a battered Ford* raced Otis T. Flywheel!  
 (= J's (17b))
- b. *Away* raced Otis T. Flywheel *in a battered Ford*.  
 (= J's (18b))
- c. Otis T. Flywheel raced *away quickly in a battered Ford*.  
 (= J's (19b))

Since it is not easy to prepose the whole string here, and since the two prepositions can be separated from each other, the string is regarded as an instance of the structure in (3.8).

Finally, *up into the clouds* in (3.5), according to Jackendoff, shares the properties of both these strings:

- (3.11) a. *Up into the clouds* went the kite! (= J's (20b))
- b. *Up* went the kite *into the clouds*! (= J's (20c))
- c. The kite went *up slowly into the clouds*. (= J's (20a))

It can be preposed like a single constituent, and it can be split up like two separate constituents. Therefore, it has both structures.

### 3.2.2. An objection

The most debatable aspect of Jackendoff's analysis is the assumption that if a PP string appears to be a constituent, it must be a PP of the form in (3.7). This is by no means a necessity -- such strings can make up PP's with other internal structures. In (3.12a) and (3.12d), I present two alternatives to (3.7). In (3.12b) and (3.12c), I re-cast

(3.7) and (3.8), respectively, in the X-bar Theory notation for the sake of uniformity. The order of the diagrams in (3.12) corresponds to the order in which the structures they represent will be discussed in the next section, where I shall frequently refer to them.

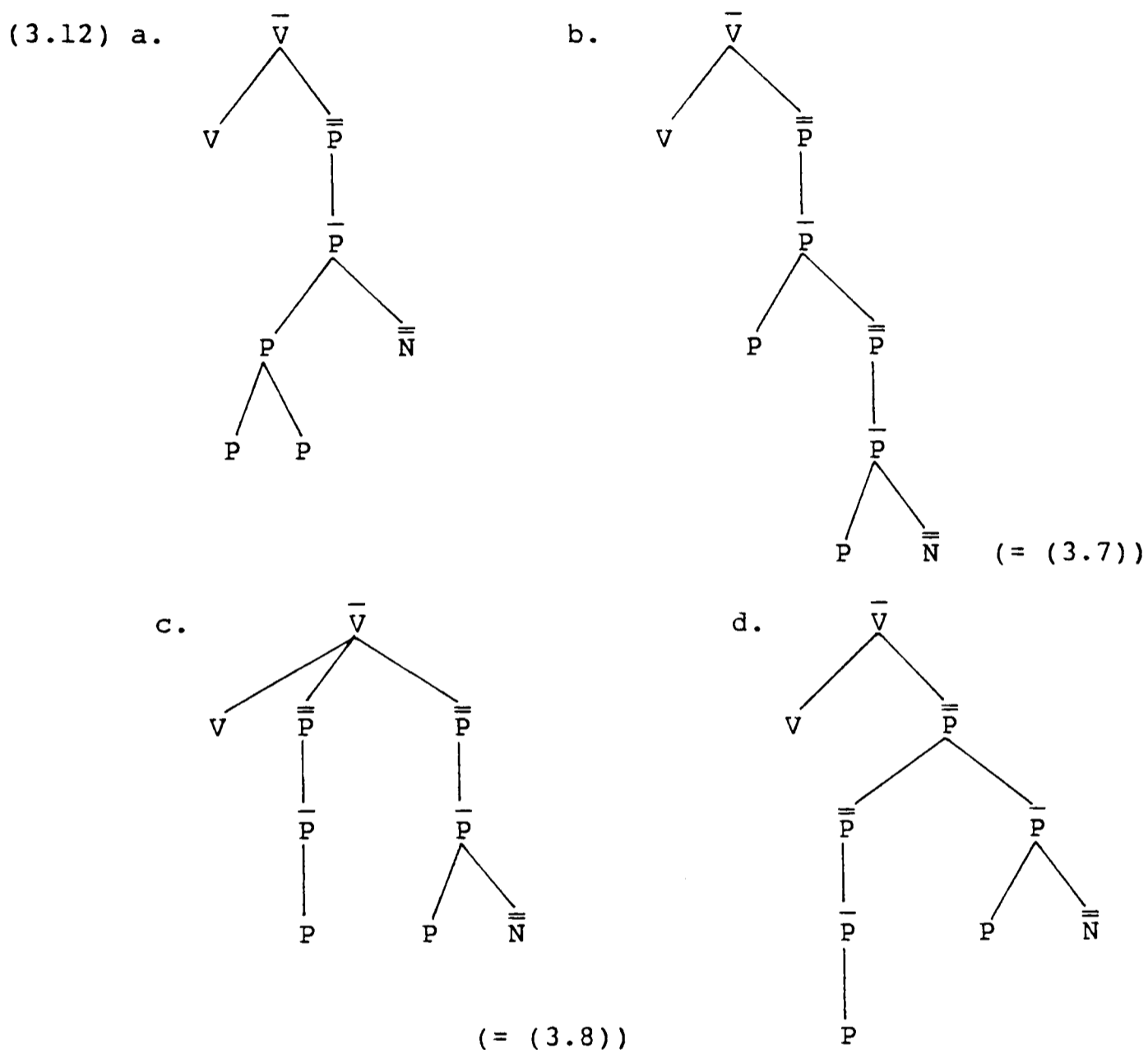

The structure in (3.12a) represents the P-P-NP string where the first two prepositions form a single complex preposition followed by an NP complement. In (3.12d), the first, intransitive, preposition is in a specifier PP of the whole constituent.

The attachment of the PP's as daughters of  $\bar{V}$  in these diagrams is arbitrary. The P-P-NP strings discussed here can be complements of verbs (e.g. verbs of motion) and they can be adverbials, daughters of  $\bar{V}$ . It seems appropriate to assume that in either case they will have the same

structure.

I am aware of four critiques of Jackendoff's original ideas. These are Mackenzie 1975, Hendrick 1976, Baltin 1978, and an unpublished paper by Waksberg 1977. The additional structures in (3.12) have been proposed in some of these works. In various ways, all these authors make the point that the P-P-NP strings which -- according to Jackendoff -- have the P-PP structure, differ in their properties and hence cannot all be associated with a single structure of this form. (3.12b) is rejected by Mackenzie and Hendrick as a possible representation of any P-P-NP string. They both argue for (3.12a) as one of the alternatives to it, and Hendrick and Waksberg introduce (3.12d).<sup>3</sup> Baltin's contribution is the most limited. He refers to Hendrick's work, though he does not completely reject the structure in (3.12b). In the course of the next section, I shall draw on some of the ideas of these authors and argue against others.

### 3.3. Revisions

#### 3.3.1. Complex prepositions

The greatest degree of agreement among Jackendoff's critics is about his analysis of the prepositional string in (3.1), repeated for convenience in (3.13).

(3.13) The nine black riders appeared *out of the night*. (= (3.1))

Apart from Waksberg, who accepts without questioning Jackendoff's view that it has the P-PP structure (Waksberg, pp. 22-23), the others note certain properties of this string, which distinguish it from the other strings and which suggest that *out and of* form a single lexical unit -- a complex preposition -- followed by an NP complement. In other

words, they advocate structure (3.12a). Hendrick and Mackenzie say so explicitly. Baltin, however, seems to regard *out* as a specifier of *of NP*.

Hendrick points out (p. 98) that it is impossible to omit either *out* or *of* from the string. His examples are given in (3.14).

- (3.14) a. \* The nine black riders appeared *of the night*. (= H's (15b))  
 b. \* The nine black riders appeared *out*. (= H's (15a))

The obligatoriness of *out* undermines Baltin's apparent claim that *out* is a specifier because specifiers are usually optional (see pp. 80-81 below).

Baltin notes (p. 37) that it is impossible to insert an intensifier between *out* and *of*:

- (3.15) \* Harpo rode the horse *out right of the barn*. (= B's (34))

Finally, Mackenzie notes that it is impossible (i) to insert the phrase *a place* between the two prepositions, (ii) to prepose *out*, and (iii) to put *of NP* in the focus position in a cleft sentence:

- (3.16) a. \* He came *out a place of the house*. (cf. M's (2))  
 b. \* *Out* he came *of the house*.  
 c. \* It was *of the house* that he came *out*.

We can add to these considerations a consideration of coordination. As illustrated in (3.17), it is impossible to conjoin *of NP* with another *of NP* following *out*.

- (3.17) \* The nine black riders appeared *out of the barn and of the castle*.

In contrast, it is possible to conjoin *of NP*'s following a noun or an adjective:

(3.18) a. We have good photos *of the colleges* and *of the river*.

b. Peter is not afraid *of spiders* but *of bats*.

Such *of NP*'s are generally regarded as forming a constituent. If *of NP* following out were also a constituent, as Jackendoff claims, then (3.17) would be acceptable. As will be shown shortly (p. 71), in the real cases of the P-PP structure, coordination of PP complements of a preposition is possible.<sup>4</sup>

All the above data point towards the conclusion that *out* and *of* constitute a single word. This word would most naturally be assigned to the category 'preposition'. Hence, the string in (3.13) has the structure in (3.12a).

### 3.3.2. Prepositions with PP complements

Only Baltin and Waksberg accept Jackendoff's structure in (3.12b). As will be recalled (cf. p. 57 above), Jackendoff associates the P-P-NP strings in (3.1)-(3.5) with this structure. I have just shown that in (3.1), the two prepositions form a complex preposition. In this sub-section, I shall focus on the properties of the string in (3.2), repeated below in (3.19a), which I take to be the only instance of the P-PP structure among Jackendoff's examples. In the next two sub-sections, I shall show that the strings in (3.3)-(3.5) have different properties and therefore must be associated with different structures.

Let us first look at Hendrick's and Mackenzie's alternatives to (3.12b) as the structure of the strings in (3.19).

- (3.19) a. A great howl of pain emerged *from inside the rain barrel*.  
 (= (3.2))
- b. John walked *from beside the river* to Mary's house.  
 (= H's (98a))
- c. He emerged *from inside the house*. (= M's (4))

According to Hendrick (p. 114), *from* in such strings is not a head but a prefix, which a productive word formation rule adds to a [- MOTIONAL] preposition such as *beside*, creating a preposition that is [+ MOTIONAL] and [- GOAL], e.g. *from beside*. This rule is said to apply to any non-motional preposition and *from* is said to be the only preposition that can serve as a prefix.

There are two major objections to this proposal. One is that *from* is not unique in this way, and the other is that combinations like *from beside* do not have the properties of a single lexical item.

The first objection is based on the data in (3.20) and (3.21). (3.20) contains attested examples. I have come across the first three, the others are from Miller (1985: 57) and Jespersen (1927: 5-6). The examples in (3.21) come from Quirk *et al.* (1985: 658) and Creswell (1983: 13). Since Creswell remarks that his sentences are only marginally acceptable, I prefix them with a question mark.

- (3.20) a. Let me take you straight *to after the 9 o'clock news*.  
 (BBC Radio 4, Today, 2.12.1982.)
- b. This cuts the ground straight *from under the Russians'*  
*feet*. (BBC Radio 4, News at Ten, 5.7.1983.)
- c. [They] moved the camera *to directly above it*.  
 (BBC Radio 4, News at Ten, 5.9.1985.)
- d. children *from on the estate* and children *from off*  
*the estate*  
 (= M's (2a), BBC Radio 4, The World at One, 20.4.1976.)

- e. We do not wish to impose plans *from on top*.  
 (= M's (2b), The Scotsman, 7.8.1976.)
- f. Then the Adjective Shift transformation is introduced which moves the adjective *from after the noun to in front of the noun*.  
 (= M's (2c), from exam script)
- g. I don't think I have been speaking to Agnes *since before the New Year*.  
 (= M's (2d), from conversation)
- h. a question which Lord F. had addressed to him *from across the table*
- i. A whiff of wind came *from in front of us*.
- j. *Till beyond Dourdan* the road is one long switchback.

- (3.21) a. He picked up the gun *from under the table*.
- b. We didn't meet *until after the show*.
- c. ? He came *via across the hill*. (= C's (33))
- d. ? He came *to behind the hill*. (= C's (34))

It is evident that all these P-P-NP strings, including those in (3.19), form a natural class semantically: the first preposition has the 'path' ('source' or 'goal') meaning, and the second has the 'place' meaning, spatial or temporal.<sup>5</sup> It is appropriate, then, to associate them with a single structure.<sup>6</sup> Given the variety of prepositions in these strings, we can see not only that Hendrick's rule cannot be restricted to *from* but also that some 'prefixed prepositions', e.g. *till after* and *to in front of*, are not [- GOAL].

The other objection to Hendrick's proposal springs from the fact that the prepositions in these strings can be separated by additional lexical material, e.g.,

- (3.22) a. John walked *from right beside the river*.  
 b. A great howl of pain emerged *from thirty feet inside the well*.  
 c. [They] moved the camera to *directly above it*. (= (3.20c))

and from the fact that the second preposition and the NP can be conjoined with another constituent:<sup>7</sup>

- (3.23) a. The troops advanced from *beside the river and within the forest*.  
 b. A great howl of pain emerged from *inside the rain barrel and under the bushes*.

As we saw earlier (p. 61), the complex preposition *out of* lends itself to neither of these operations. It will be illustrated later (pp. 71-72) that the preposing of the first preposition, and the clefting of the second preposition and the NP are impossible with these strings, but this is consistent with the P-PP structure and need not imply that the prepositions form a complex preposition.

Mackenzie's alternative to Jackendoff's P-PP structure is based on the observation that the two prepositions can be separated by the phrase *a place*:

- (3.24) He emerged *from a place inside the house*. (cf. M's Table 2)

This leads him to the claim (p. 34) that phrases like *from inside the house* in (3.19c) and *from a place inside the house* in (3.24) have a common underlying structure, something like (3.25), where the second preposition and the NP are embedded in an NP complement of the first preposition.

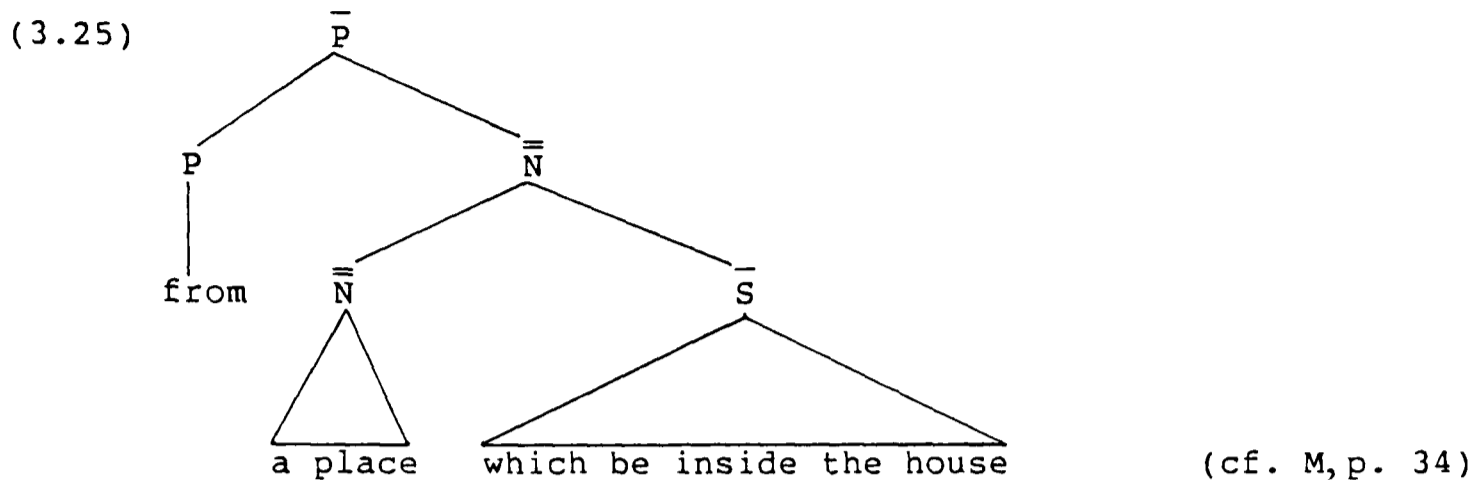

In the course of derivation, *which be* is deleted, and *a place* is either retained, in which case (3.24) arises, or also deleted, in which case (3.19c) arises. Presumably, if Mackenzie had considered temporal strings like *until after the show*, *after* would have been said to be preceded by *a time which be* in an identical structure, subject to deletion.

One must bear in mind, however, that Mackenzie's analysis -- set within the Generative Semantics framework -- dates back to the time when deletion of arbitrary lexical material was generally accepted within transformational grammar. Within the present mainstream transformational grammar this is not a permissible operation (cf. Baker 1979: 552). Therefore, we could not accept (3.25) as an alternative to Jackendoff's structure (3.12b).

One might, however, pursue Mackenzie's more general claim, namely, that prepositions do not subcategorize for a PP, only for an NP. In this situation, one might suggest that rather than (3.25), the P-P-NP strings under discussion have one of the structures in (3.26).

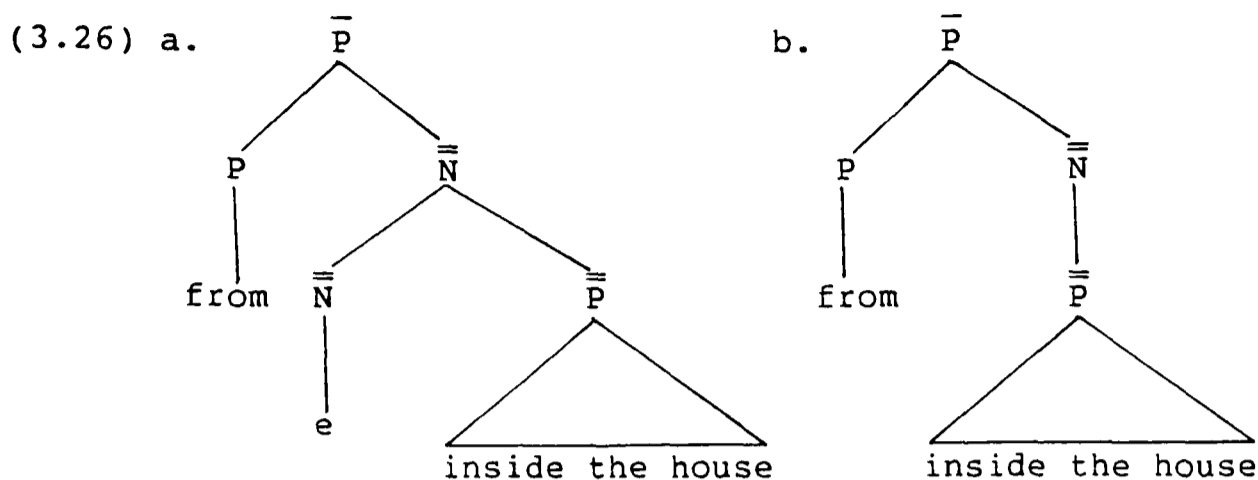

Here, the second preposition and the NP are also embedded in an NP complement of the first preposition, but the NP either has a base-generated empty head (cf. (3.26a)) or it is an exocentric (headless) construction (cf. (3.26b)). Obviously, no deletion would have to be invoked to generate strings like *from inside the house*.

But in spite of this advantage, the structures in (3.26) are not viable alternatives to (3.12b), given the assumptions of the GB framework. Considering (3.26a) within GB, one must ask what type of empty category the head of the NP is: a trace, PRO, or *pro* (Chomsky 1977: 76; 1982: 78-79). Traces, we recall (cf. Chapter 1, p. 20 above), are left after movement of a constituent. PRO and *pro* are base-generated. Clearly, the empty NP in (3.26a) could not be a trace because no movement from this position has taken place.

Could it be PRO, then? One of the properties of PRO is that it must either have an overt antecedent in the same sentence (e.g. *They want* [ $\bar{S}$  [ $S$  PRO to win]], where PRO is coreferential with *they*) or has 'arbitrary reference' (e.g. *It's unclear* [ $\bar{S}$  what [ $S$  PRO to do]], where the referent of the understood subject of the infinitive is any individual within a given context; cf. Chomsky (1982: 79)). A PRO associated with the object of a preposition in a structure like (3.26a) would seem not to fall into either of these categories. Therefore, it is

unlikely that the empty NP could be PRO.

It could not be *pro* either, however. First, *pro* is primarily associated with the empty subject position in finite clauses in the so-called 'pro-drop' languages (e.g. Italian and also Polish; cf. Chomsky (1982: 85)). As English is not a pro-drop language, it is unlikely that *pro* should occur there in some minor construction. To argue that *pro* appears in (3.26a), it would first have to be shown that there are other types of construction in English in which *pro* occurs.

Secondly, it is assumed that *pro* is identified by agreement morphology (Chomsky 1982: 85). In our case, agreement markers would be attached to the preposition whose complement NP is headed by *pro*. Since agreement is not associated with prepositions in English, there is no evidence for *pro* in this construction.

As for (3.26b), it assumes an NP with no head, in violation of the X-bar Theory requirement that phrasal categories have a head. I shall spell out objections to this kind of structure in Chapter 7 (pp. 209-210), where I shall be considering the category status of subject and object PP's.

The fact that none of the three types of NP considered above could be part of the structure of P-P-NP strings like those in (3.19)-(3.21) provides negative evidence in favour of Jackendoff's structure (3.12b). Positive evidence for this structure and against any of the other three postulated structures is provided by a consideration of the contrast in acceptability in the following pairs of examples:<sup>8</sup>

(3.27) a. *Which house* did he emerge from \_\_\_?

b. \* *Inside which house* did he emerge from \_\_\_?

(3.28) a. *That old house*, the children ran to \_\_!

b. \* *In front of that old house*, the children ran to \_\_!

(3.27) contains *wh*-questions, and (3.28) contains sentences with preposed phrases in topic position. An important feature here is that the prepositions at the end of these examples are followed by gaps. In (3.27a) and (3.28a), the gap contains a trace left by the fronted NP's *which house* and *that old house*, respectively. The relevant parts of the structures of these sentences are presented in (3.29)

(3.29) a. [ $\bar{N}$  Which house] did he emerge [ $\bar{p}$  from [ $\bar{N}$  t]]?

b. [ $\bar{N}$  That old house] the children ran [ $\bar{p}$  to [ $\bar{N}$  t]]!

As for (3.27b) and (3.28b), they would involve structures like either (3.30) or (3.31).

(3.30)

a. [ $\bar{N}$  Inside which house] did he emerge [ $\bar{p}$  from [ $\bar{N}$  t]]?

b. [ $\bar{N}$  In front of that old house] the children ran [ $\bar{p}$  to [ $\bar{N}$  t]]!

(3.31)

a. [ $\bar{p}$  Inside which house] did he emerge [ $\bar{p}$  from [ $\bar{p}$  t]]?

b. [ $\bar{p}$  In front of that old house] the children ran [ $\bar{p}$  to [ $\bar{p}$  t]]!

In (3.30), we also have NP traces, left by the fronted phrases *inside which house* and *in front of that old house*, respectively, on the assumption that they are NP's. Given the identity of the structures in (3.29) and (3.30), the contrast between the examples in (3.27) and (3.28) is unexpected. In (3.31), however, we have PP traces, assuming that the fronted phrases are simply PP's. Thus, there is a difference between the structures associated with the pairs in (3.27) and (3.28).

The contrast in acceptability between these examples can be attributed to this difference.<sup>9</sup>

I noted earlier (p. 65) that the prepositions in these P-P-NP strings can be separated by additional lexical material (cf. (3.22) above), and that the second preposition and the NP can be conjoined with another constituent (cf. (3.23) above). These two properties of these strings are compatible with the postulated P-PP structure. The additional lexical material in (3.22) is the specifier of the complement PP, a daughter of  $\bar{P}$  (cf. Chapter 1, p. 15-16). (3.32b) illustrates the structure of the string in (3.22a), repeated as (3.32a).

(3.32) a. John walked *from right beside the river*. (= (3.22a))

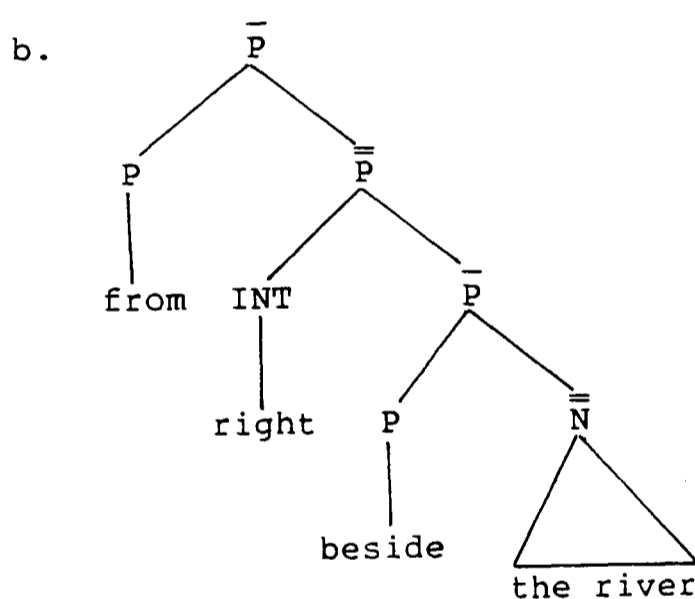

Unlike specifiers, adverbials cannot intervene between the prepositions:

(3.33) \* John walked *from quickly beside the river*.

This too is consistent with the P-PP structure, as adverbials, in general, cannot separate a head preposition and its NP complement:

(3.34) \* John walked *from quickly the river*.

Turning to (3.23), the conjuncts there are maximal projection constituents in a structure like (3.35b).<sup>10</sup> The example in (3.35a) is the same as (3.23a).

- (3.35) a. The troops advanced from *beside the river* and *within the forest*. (= (3.23a))

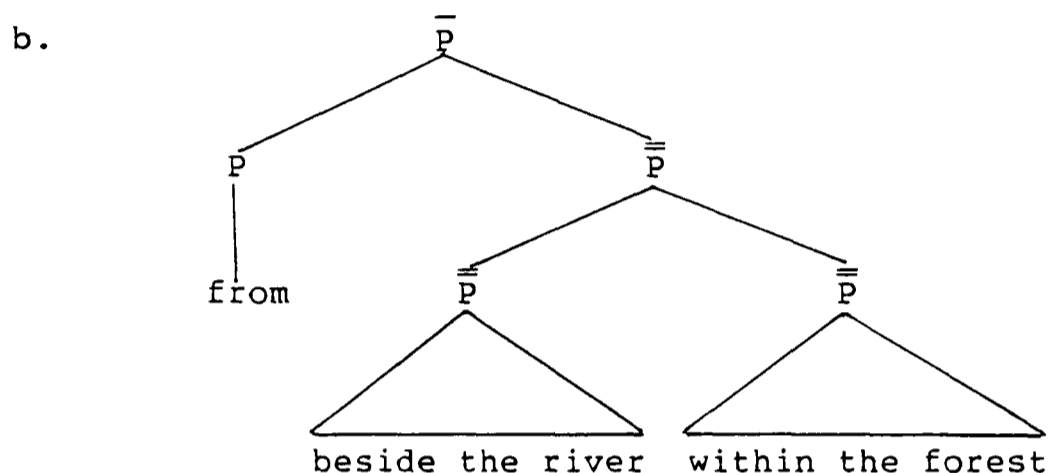

Two other properties of these strings lend further support to the P-PP analysis. I have mentioned briefly (p. 65) that it is impossible to prepose the first preposition, or to place the second preposition and the NP in focus position in a cleft sentence. (3.36) and (3.37) illustrate, respectively.

- (3.36) a. \* *From* a great howl of pain emerged *inside the rain barrel*.

- b. \* *To* the children ran *in front of that old house*.

- (3.37) a. \* It was *inside the rain barrel* that a great howl of pain emerged *from*.

- b. \* It was *in front of that old house* that the children ran *to*.

In (3.36), we have a preposed preposition that is the head of a PP. As is shown in (3.38), heads of 'ordinary' (i.e. P-NP) PP's cannot be preposed either.

(3.38) \* *From* he emerged a box.

In (3.37) above, we have another instance of a preposition followed by a trace of a complement PP, the same phenomenon as that in (3.27b) and (3.28b) above.

Given all these considerations, there is a good case for analyzing P-P-NP strings like those in (3.19)-(3.21) in terms of structure (3.12b).

### 3.3.3. Non-constituents

In this sub-section, I consider the properties of the P-P-NP string in (3.6), repeated in (3.39).

(3.39) Otis T. Flywheel raced *away in a battered Ford*. (= (3.6))

According to Jackendoff (cf. pp. 57-58 above), it has (3.12c) as its structure: *away* and *in a battered Ford* form two separate constituents, not a single constituent.

Jackendoff's critics offer no significant discussion of this string, not surprisingly, as the analysis is non-controversial. However, since Jackendoff and Hendrick postulate (3.12c) also for the P-P-NP string *up into the clouds* in (3.5), I shall repeat Jackendoff's arguments associated with *away in a battered Ford*, add two more, and suggest that the two strings differ in certain respects, which implies that *up into the clouds* is not an instance of the same structure as *away in a battered Ford*. I shall also point out a hitherto apparently overlooked property of PP's. Unfortunately, the data here and in the next sub-section are not very clear and my conclusions are tentative.

As noted earlier (p. 58), Jackendoff bases his analysis of *away in a battered Ford* on the three examples in (3.10), repeated in (3.40).

- (3.40) a. ?\* *Away in a battered Ford* raced Otis T. Flywheel.  
 (= (3.10a))
- b. *Away* raced Otis T. Flywheel *in a battered Ford*.  
 (= (3.10b))
- c. Otis T. Flywheel raced *away quickly in a battered Ford*.  
 (= (3.10c))

(3.40b) and (3.40c) can be taken to show that the prepositions here can be separated from each other in ways that the prepositions in the P-PP structure cannot:

- (3.41) a. \* *From* a great howl of pain emerged *inside the rain barrel*.  
 (= (3.36a))
- b. \* John walked *from quickly beside the river*. (= (3.33))

Jackendoff takes (3.40a) to show that the string is a non-constituent. I shall return to this datum shortly (p. 74).

The elements of this string have two other properties that suggest that the analysis is correct. One, noted in passing by Mackenzie (p. 34), is that the second preposition and the NP can be preposed, just as the first preposition can in (3.40b):

- (3.42) *In a battered Ford*, Otis T. Flywheel raced away. (= M's (9d))

The other is that as two separate PP's, *away* and *in a battered Ford* can occur in either order: that in (3.39) and that in (3.43).<sup>11</sup>

- (3.43) ? Otis T. Flywheel raced *in a battered Ford away*.

The somewhat reduced acceptability of this sentence can be attributed to the relative 'weight' of *away*. It seems that *away* lacks sufficient 'heaviness' to occupy the final position in a sentence. For the sake of comparison, *away* can be replaced with another 'light' directional expression, *there*, and with a 'heavier' *to the garage*. As illustrated in (3.44), *there*, like *away*, is preferable in non-final position but, as illustrated in (3.45), *to the garage* is equally acceptable in either position.

(3.44) a. Otis T. flywheel raced *there in a battered Ford*.

b. ? Otis T. Flywheel raced *in a battered Ford there*.

(3.45) a. Otis T. Flywheel raced *to the garage in a battered Ford*.

b. Otis T. Flywheel raced *in a battered Ford to the garage*.

Let us now return to the example in (3.40a), with the whole string preposed. As indicated, Jackendoff's judgement of its acceptability is uncertain, and my informants do not completely reject it. A cleft sentence with this string in focus position seems to be similar:

(3.46) ? It was *away in a battered Ford* that Otis T. Flywheel raced.

It appears that here, as in (3.40a), movement of a non-constituent is involved, in violation of one of the fundamental assumptions of transformational grammar -- that only single constituents can be moved (cf. Schwartz 1972). This assumption could be maintained if this string were to be analyzed, on occasions, as a single constituent, as well as two separate constituents. To achieve such an analysis (within a transformational framework), we can postulate an optional restructuring transformation. Its input will be structure (3.12c), repeated in

(3.47a), and its output, something like (3.47b) or (3.47c).

(3.47) a.

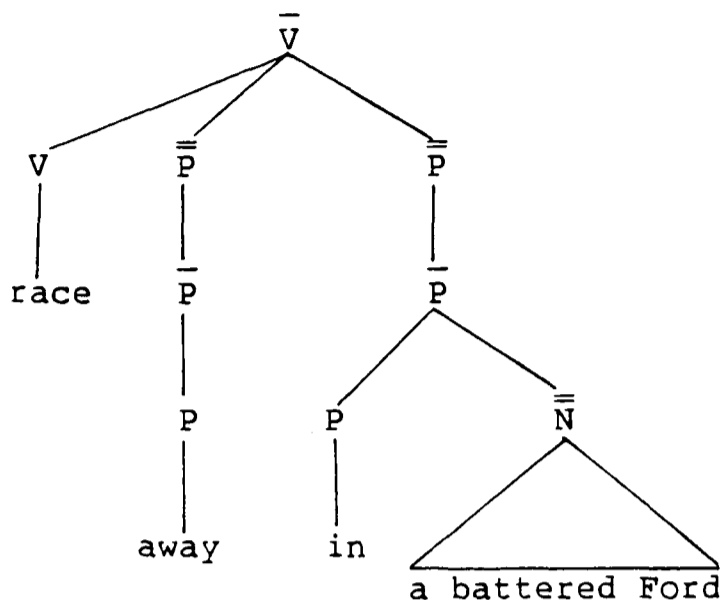

(cf. (3.12c))

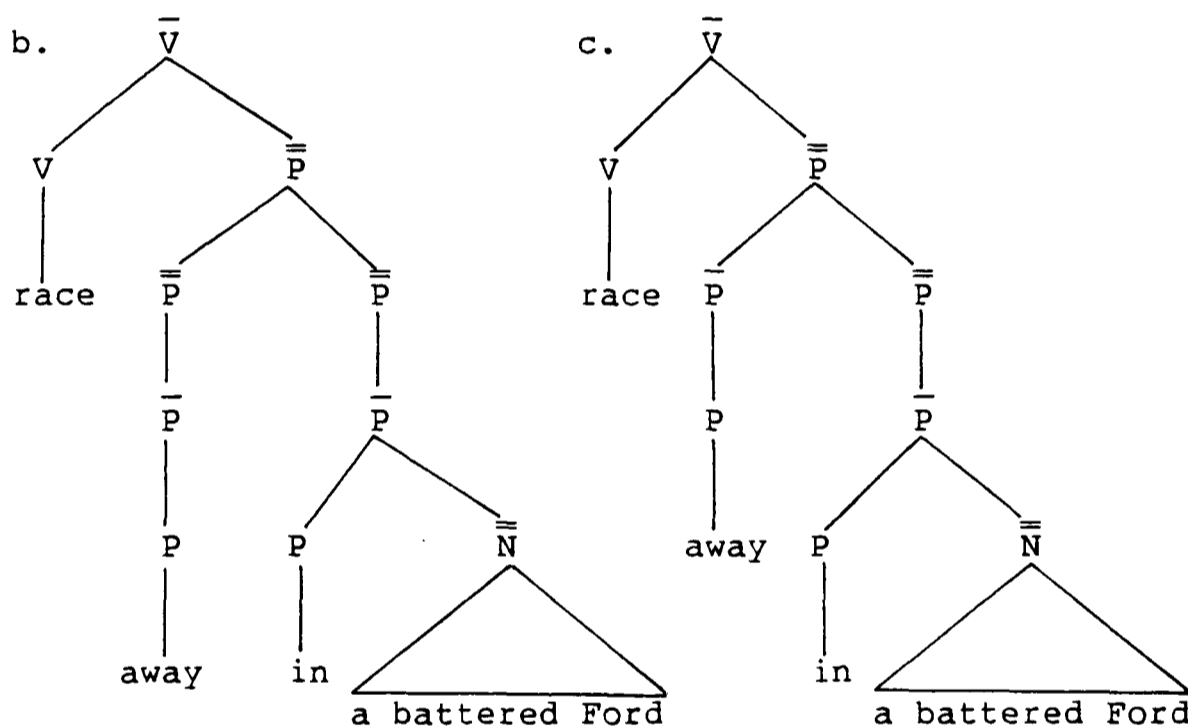

In (3.47b), the second PP appears 'Chomsky-adjoined' (cf. Akmajian and Heny 1976: 149; Radford 1981: 169) to the first PP. In (3.47c), the second PP has been lowered into, and attached as a daughter of, the first PP. My preference is for the latter structure since there, the directional preposition *away* is clearly the head of the PP and this can be seen as triggering the subject-verb inversion in (3.40a), a phenomenon associated with preposing of directional phrases (cf. Emonds 1976: 29-30; McCawley 1982: 180).

On the face of it, the postulated restructuring appears to be an *ad hoc* device. However, support to this analysis is lent by the following examples:

- (3.48) a. It was *with their father about politics* that the boys used to argue.
- b. It was *on Wednesdays in the library* that they held their seminars.

- (3.49) a. *With their father about politics*, the boys used to argue all day.
- b. *On Wednesdays in the library*, they held their seminars.

In (3.48), we have two complement PP's and two adverbial PP's in the focus position in cleft sentences, and in (3.49), the same PP's appear preposed. In both cases, they appear in positions with which single constituents are associated. It seems that -- assuming clefting and preposing affect single constituents -- we must recognize that what is normally a string of PP's can sometimes form a single constituent. Within a transformational framework, this means that PP's more generally can undergo restructuring. As far as I know, such examples have escaped the attention of other linguists.

Finally, let us compare the properties of the P-P-NP string *up into the clouds* in (3.5), repeated in (3.50), with those of *away in a battered Ford*.

- (3.50) The kite went *up into the clouds*. (= (3.5))

As illustrated by Jackendoff's examples in (3.11b) and (3.11c) above, repeated in (3.51), there is some indication that two separate constituents are involved here.

- (3.51) a. *Up* went the kite *into the clouds*. (= (3.11b))  
 b. The kite went *up slowly* *into the clouds*. (= (3.11c))

The same patterns occur with *away in a battered Ford*, as illustrated in (3.40b) and (3.40c) above.

However, the two strings seem to differ from each other in two respects: in the possibility of preposing of the second preposition and the NP, and in the relative order of the P and the P-NP. Since *into the clouds* is a directional PP, its preposing should trigger subject-verb inversion (cf. Emonds 1976: 29-30; McCawley 1982: 180).

- (3.52) a. *In a battered Ford*, Otis T. Flywheel raced away! (= (3.42))  
 b. \* *Into the clouds*, went the kite up!

- (3.53) a. ? Otis T. Flywheel raced *in a battered Ford* away. (= (3.43))  
 b. \* The kite went *into the clouds* up.

These differences are unexpected if *up* and *into the clouds* are two separate PP's. In the next sub-section, I shall argue that *up into the clouds*, together with the two remaining P-P-NP strings in Jackendoff's original examples, is an instance of a constituent of the form in (3.12d), where the first preposition is a specifier and the second, the head of the PP.

#### 3.3.4. Prepositions as specifiers

The remaining P-P-NP strings to be considered are those in

(3.3)-(3.5), repeated in (3.54).

- (3.54) a. Sam disappeared *down into the darkness*. (= (3.3))  
 b. Chico raced *away from Mrs Claypool*. (= (3.4))  
 c. The kite went *up into the clouds*. (= (3.5))

According to Jackendoff (cf. p. 57 above), they all have the P-PP structure (3.12b), and the last string has additionally the non-constituent structure (3.12c). As I have just shown, however, *up into the clouds* cannot be regarded as two separate constituents.

Waksberg argues against associating the P-PP structure with strings like those in (3.54a) and (3.54c). She argues that they should be analyzed as constituents in which the first preposition is a specifier and the second, the head of the PP -- structure (3.12d). The following are among her examples:

- (3.55) a. She put the can *up on the shelf*. (= W's (1))  
 b. The light penetrated *down through the darkness of the tunnel*. (= W's (12))  
 c. Samuel walked right *up to the pilot* and hit him over the head with a chair. (= W's (40))

Hendrick argues that the string *down into the darkness* in (3.54a) should be analyzed in this way (p.97), and claims that *away* and *from* in (3.54b) form a single lexical item (p. 121 n. 11).<sup>12</sup> *Up into the clouds* in (3.54c), according to Hendrick (p. 100), involves two separate constituents (structure (3.12c)) but, optionally, the second PP can be moved into the first by a 'complement formation' transformation, in result of which a constituent of the form P-PP (structure (3.12b)) is created.

Mackenzie (pp. 33-34) offers a Generative Semantic analysis, within which the first preposition in his example in (3.56a) is subject to lexical decomposition as in (3.56b).

- (3.56) a. He jumped *down into the box*. (= M's (3))  
 b. He jumped *into the box, which was at a lower level*. (= M's (5))

It seems that we can regard this analysis as analogous to one in which the decomposed preposition is treated as a specifier within a more concrete framework assumed here.

In the remainder of this sub-section, I shall bring together Hendrick's and Waksberg's arguments for the specifier-head analysis, supplementing them with some additional considerations.

First, however, I want to question Jackendoff's acceptability judgements of two examples involving the P-P-NP string in (3.54b), which will lead me to reject both his and Hendrick's analyses of this string. The examples in question are the following:

- (3.57) a. ?\* *Away* raced Chico *from Mrs Claypool!* (= (3.9b))  
 b. ?\* Chico raced *away quickly from Mrs Claypool*. (= (3.9c))

As noted earlier (p. 57-58), Jackendoff regards these data as evidence for the P-PP structure of the string. Within his analysis, these examples are ungrammatical because in both cases, a head preposition has been separated from its complement -- by movement in (3.57a) and by an adverbial in (3.57b) (cf. (3.33) and (3.34) above). Within Hendrick's analysis, these examples are ungrammatical because a single lexical item has been broken up.

However, as indicated, Jackendoff's judgements of these examples are tentative, and the informants that I have consulted are prepared to accept them. I assume, therefore, that these examples are grammatical.

Having made this point, we note that the same pattern occurs with the other two strings in (3.54):

(3.58) a. ? *Down* disappeared Sam *into the darkness!*

b. Sam disappeared *down quietly into the darkness.*

(3.59) a. *Up* went the kite *into the clouds!* (= (3.51a))

b. The kite went *up slowly into the clouds.* (= (3.52b))

Given (3.58), we must reject Jackendoff's analysis of *down into the darkness* as involving the P-PP structure.<sup>13</sup>

In addition to (3.58), one should quote Hendrick's and Waksberg's objections to Jackendoff's analysis of this string, based on the following two properties distinguishing between specifiers and heads: (i) heads but not specifiers are subcategorized for by the complement-taking element, and (ii) heads are obligatory but specifiers are optional.<sup>14</sup>

The former is demonstrated with verbs that allow a restricted range of PP complements, such as *disappear*:

(3.60) a. Sam disappeared *into the darkness.* (= H's (7b))

b. \* Sam disappeared *down.* (= H's (7a))

*Disappear* allows a PP complement headed by the transitive preposition *into* but not a PP complement headed by the intransitive *down*. Therefore, *down* may well be a specifier in the P-P-NP string in (3.54a).

(3.60) also shows that *down* is optional in the sense that its omission does not cause ungrammaticality or a major change of meaning. This is also the case with *away* and *up* in the other two strings in (3.54):<sup>15</sup>

- (3.61) a. Chico raced (*away*) from { ? Mrs Claypool.  
 { the post office.
- b. The kite went (*up*) into the clouds.

In contrast, in strings like *from beside the river*, where both prepositions are heads of PP's in the P-PP structure, either preposition can appear as the head of a 'simple' PP complement of a verb like *walk*, e.g.,

- (3.62) a. John walked *from the river*.  
 b. John walked *beside the river*.

and -- as (3.62b) demonstrates -- the omission of the first preposition causes, arguably, a more substantial change of meaning than that caused by the omission of *down*, *away*, or *up*.<sup>16</sup>

The interpretation of the P-P-NP strings in (3.54) (and in (3.55) and (3.56a)) suggests that they form a natural class. Both prepositions in each string have directional meaning but it is the second preposition (with its NP complement) that carries the main meaning. The peripheral semantic role of the first preposition, combined with its optionality, will be reflected in the syntax if the preposition is regarded as a specifier within the PP.

The specifier-head analysis of the strings in (3.54) seems to make the right predictions of their properties, partially noted above.

First, the strings are constituents, as required in view of the fact that they can be preposed:

- (3.63) a. *Down into the darkness* disappeared Sam!  
 b. *Away from Mrs Claypool* raced Chico! (= (3.9a))  
 c. *Up into the clouds* went the kite! (= (3.11a))

Secondly, the second preposition and the NP form only a  $\bar{P}$  and hence, as a constituent of intermediate category, they cannot be moved. Mackenzie notes (p. 33) that in his example in (3.56a) above, *He jumped down into the box, into the box* cannot be clefted,

- (3.64) \* *It was into the box that he jumped down.* (cf. M's Table 2)

and he regards the following as unacceptable:<sup>17</sup>

- (3.65) \* *From Mrs Claypool* Chico raced away! (= M's (8d))

With the other two of our strings, it is also impossible to prepose the second preposition and the NP:

- (3.66) a. \* *Into the darkness* Sam disappeared down!  
 b. \* *Into the clouds* went the kite up! (= (3.52b))

Thirdly, as a specifier, the first preposition can precede the head of the phrase but it cannot follow it:

- (3.67) a. \* Sam disappeared *into the darkness* down.  
 b. \* Chico raced *from Mrs Claypool* away.  
 c. \* The kite went *into the clouds* up. (= (3.53b))

The data in (3.63)-(3.67) are, of course, compatible with the P-PP structure assumed by Jackendoff. However, the examples in (3.68) and (3.69), and in (3.71) below seem to support the specifier-head analysis.

(3.68) a. ? *Down* disappeared Sam into the darkness! (= (3.58a))

b. ? *Away* raced Chico from the post office! (cf. (3.57a))

c. *Up* went the kite into the clouds! (= (3.51a))

(3.69) a. *How far down* did Sam disappear into the darkness?

b. *How far away* did Chico race from the post office?

c. *How high up* did the kite go into the clouds?

If the first prepositions in these strings were heads in the P-PP structure, they could not be preposed (cf. (3.36) above). Regarded as specifiers, their capacity to be preposed can be viewed as an instance of the violation of the Left Branch Condition (due to Ross 1967: 114).<sup>18</sup> As pointed out by Emonds (1976: 185), a left branch can be extracted out of a PP. His example, with the relevant part of structure indicated, is in (3.70).<sup>19</sup>

(3.70) *How many feet* should I put the table [ $\bar{p}$  \_\_ behind

the house]? (= E's (77), p. 185)

In the final set of examples, we have two prepositions separated by an adverbial. Again, Jackendoff's acceptability judgement of (3.71b) appears to be more stringent than that of my informants.

(3.71) a. Sam disappeared *down quietly* into the darkness. (= (3.58b))

b. Chico raced *away quickly* from Mrs Claypool. (= (3.57b))

c. The kite went *up slowly* into the clouds. (= (3.51b))

If these strings had the P-PP structure, we would not expect adverbials to occur between a head preposition and its complement. Assuming the specifier-head structure, however, an adverbial in this position is less surprising, given that it appears to be possible also between another type of specifier -- a measure phrase -- and a head preposition:

(3.72) a. ? John ran *three miles swiftly* around the track.

b. ? She is *two weeks always* behind the schedule.

There is some evidence, then, for considering structure (3.12d) as appropriate for these P-P-NP strings. With respect to *away from Mrs Claypool*, if this string had the P-PP structure, then *away* would be an exceptional preposition that could take a PP or no complement but not an NP complement as well (cf. \**Chico raced away Mrs Claypool*).

#### 3.4. Wider implications of the P-PP structure

In this section, I shall consider two proposals which have a bearing on the distribution of PP's, and which are undermined by P-P-NP strings like *from inside the rain barrel*. As argued in Sub-section 2.3.2, they consist of a preposition followed by a PP complement (object of a preposition). One proposal is Hoekstra's (1984: 85) Unlike Category Condition (UCC), and the other Stowell's (1981: 146) Case Resistance Principle (CRP). It will become apparent that the scope of the latter is wider than the scope of the former in so far as their prediction about where PP's can and cannot appear is concerned.

The UCC is presented in (3.73).

#### (3.73) Unlike Category Condition (UCC)

At S-structure, no element of category X may govern  
a projection of X

This means, for example, that a noun cannot take an NP as its complement, an adjective cannot take an AP as its complement, and that a preposition cannot take a PP as its complement.<sup>20</sup> The first two predictions are schematically illustrated in (3.74) and (3.75), respectively, based on Hoekstra's examples (pp. 85-86). In (3.74), we have a derived nominal, and in (3.75), a 'raising' adjective.<sup>21</sup>

(3.74) a. \* the capture the city  
(cf. H's (108a), p. 85)

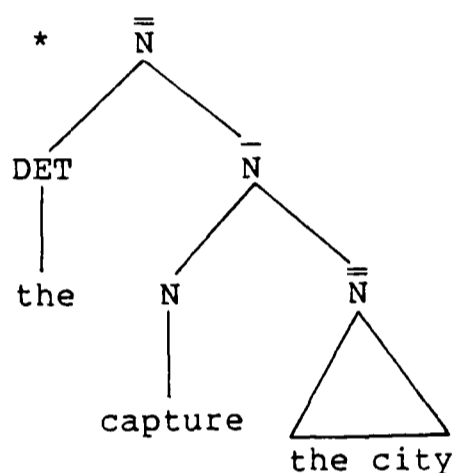

b. the capture of the city

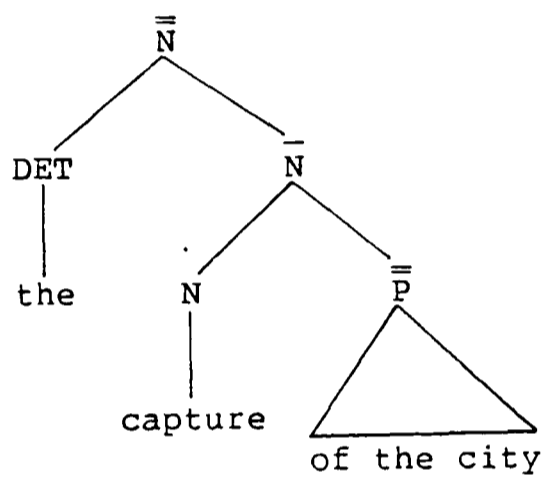

(3.75) a. \* John is certain dead.  
(cf. H's (111b), p. 86)

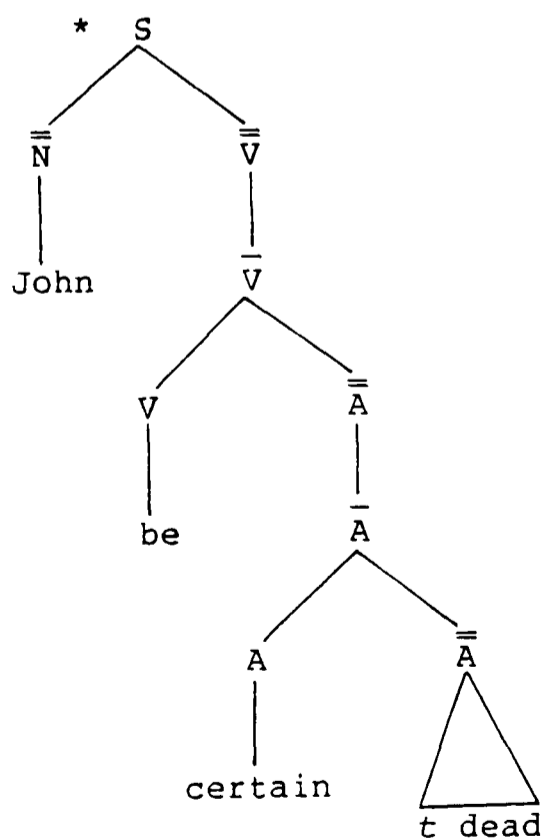

b. John is certain to be dead.  
(cf. H's (111a), p. 86)

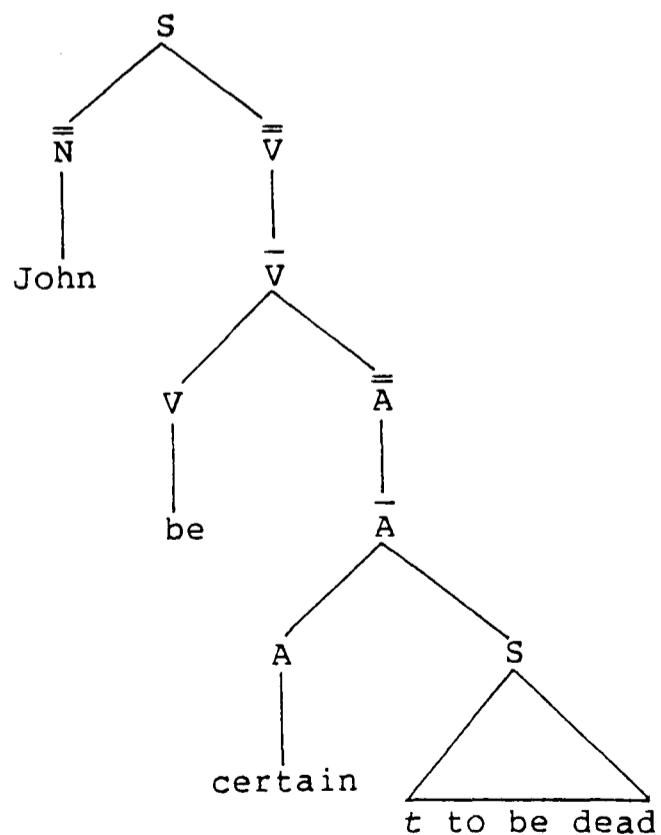

Hoekstra recognizes (p. 87) that two types of PP pose a problem for his Condition. One is PP's like *from inside the rain barrel*, which have the prohibited P-PP structure. The other is the so-called 'absolute construction' PP's like *with Cruyff in the goal* and *without a tie around his neck*, which he regards as another instance of this structure (p. 87). For example, *without a tie around his neck* has the following structure, where *a tie* is the subject of the predicative PP (the lower  $\bar{P}$ ) and a specifier of the complement PP ( $\bar{\bar{P}}$ ):

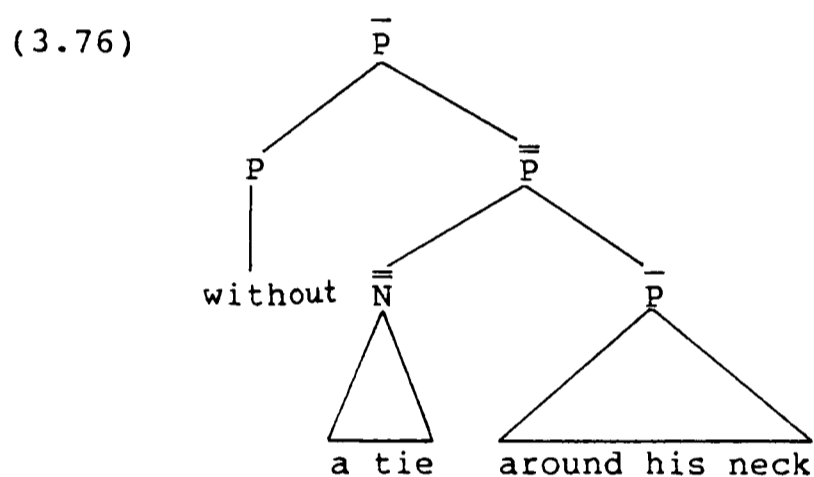

While Hoekstra does not offer any explanation of these violations of the UCC, Beukema (1985: 19) tentatively suggests a solution to the problem posed by (3.76). This, however, crucially depends on the assumption that the complement PP contains an NP specifier and so cannot be extended to the simpler P-PP structure associated with the P-P-NP strings. Thus, these PP's continue to act as counter-examples to the UCC.

Let us now turn to the CRP as formulated in Stowell (1981: 146):

(3.77) Case Resistance Principle (CRP)

Case may not be assigned to a category bearing  
a Case-assigning feature

Case and Case assignment will be considered more fully in Chapters 8 and 9. In the present context, it is sufficient to say that Stowell (pp.

42-43, 145-146) regards the features [- N], and [+ TENSE] when accompanied by [+ PAST] or [- PAST] as the elements that may assign Case to a constituent that they govern. Thus, to say, for example, that [- N] may assign Case to a constituent means that a verb (which is [- N, + V]) or a preposition (which is [- N, -V]) may assign Case to its complement.<sup>22</sup> Since PP's bear the feature [- N] and finite clauses ( $\bar{S}$ 's) bear the feature [+ TENSE] accompanied by [+ PAST] or [- PAST], Case may not be assigned to them, given the CRP. NP's, on the other hand, which are [+ N], may and, indeed, must be assigned Case (pp. 111, 145-146).

As a result of the CRP, PP's and  $\bar{S}$ 's must not appear in those positions at S-structure, in which they would be assigned Case. These include object of a preposition, object of a transitive verb, and subject position. In other words, PP's and  $\bar{S}$ 's must not appear in positions in which NP's can appear. It is clear that the CRP has a wider scope than the UCC: with respect to PP's, only PP objects of prepositions are ruled out by the UCC.

Obviously, the P-P-NP strings like *from inside the rain barrel* are counter-examples to the CRP as much as they are to the UCC. However, while Hoekstra acknowledges the problem, Stowell denies that prepositions can ever take a PP as object (p. 143). He gives the following pair of examples to illustrate this claim:

- (3.78) a. We talked [ $\bar{p}$  about [ $\bar{N}$  the direction of the wind]]  
 (= S's (57b), p. 143)
- b. \* We talked [ $\bar{p}$  about [ $\bar{p}$  from the west]]  
 (= S's (58b), p. 143)

In (3.78a), we have the preposition *about* followed by an object NP, to which Case may be and is assigned, and in (3.78b), we have this preposition followed by an object PP, to which -- according to the CRP -- Case may not be assigned. Hence, according to Stowell, (3.78b) is

ungrammatical.

As I have already pointed out (cf. n. 6 to this chapter), apart from the path prepositions *from*, *since*, etc., *about* is among prepositions that can take a PP complement, e.g.:

(3.79) a. We talked *about before the storm*. (cf.(3.78a))

b. They are thinking *about after lunch*.

Given the acceptability of these examples in addition to the acceptability of *from inside the rain barrel*, etc., we must conclude that Stowell's claim that PP's do not occur in Case marked positions is unsubstantiated. These data, then, raise some doubt about the validity of the CRP. In Chapter 4 (pp. 132-134), similar doubts will be raised in connection with constructions where a preposition is followed by an  $\bar{S}$  complement, and in Chapter 8, I shall argue that PP's not only may but must be assigned Case in some circumstances.

### 3.5. Conclusion

In the course of this chapter, I have focussed on the syntactic properties of six P-P-NP strings selected from Jackendoff's (1973) original article. In addition, I have cited examples from other works, whose authors have chosen to discuss Jackendoff's proposal using their own data. I have considered four structures with which these strings could plausibly be associated, each of which has been advocated by one or more authors.

Only Hendrick 1976 has critically discussed all these or similar strings previously. I agree with him that *out of* is a complex preposition, that *down* in *Sam disappeared down into the darkness* is a specifier of *into the darkness*, and that *away* and *in a battered Ford* in *Otis T. Flywheel raced away in a battered Ford* are two separate

constituents (which is also Jackendoff's position).

I disagree with Hendrick on the analysis of *up into the clouds* in *The kite went up into the clouds*. Rather than another instance of two separate constituents, I have suggested -- following Waksberg 1977 -- that this involves a specifier preposition, as does *away from Mrs Claypool* in *Chico raced away from Mrs Claypool*, which Hendrick regards as containing a complex preposition *away from*.

Finally, I have rejected Hendrick's analysis of a string like *from inside the rain barrel* as involving a complex preposition *from inside*. In this case, I have defended Jackendoff's view that this is an instance of the P-PP structure. Contrary to Mackenzie, I have argued that this structure is preferable to a P-NP structure with the PP embedded in the NP.

I have considered several criteria in the attempt to establish the structures of these strings. They are listed in Table 3.1 on the next page, with an indication of how the six strings respond to them and what structures they form. The numbers preceding the examples correspond to the numbers of the sentences from which they are taken. The numbers following the examples correspond to the numbers of the diagrams depicting their respective structures presented at the beginning of the discussion (cf., respectively, pp. 56 and 59 above). I have thought it unnecessary or impossible to apply all of the criteria to all the strings examined in the text. This too is indicated in the table. The symbols used in the table are explained at the bottom of it.

| Examples   | (3.1)<br>...out<br>of the<br>night<br>(3.12a) | (3.2)<br>...from<br>inside the<br>rain barrel<br>(3.12b) | (3.3)<br>...down<br>into the<br>darkness<br>(3.12d) | (3.4)<br>...away<br>from Mrs<br>Claypool<br>(3.12d) | (3.5)<br>...up<br>into the<br>clouds<br>(3.12d) | (3.6)<br>...away in<br>a battered<br>Ford<br>(3.12c) |
|--|---|--|---|---|---|--|
| Criteria   |   |  |   |   |   |  |
| A. Prepose P <sub>1</sub> -P <sub>2</sub> -NP      | +   | +  | +   | +   | +   | +  |
| B. Prepose P <sub>1</sub>                          | *   | *  | ?   | ?   | +   | +  |
| C. Prepose P <sub>2</sub> -NP                      | *   | *  | *   | *   | *   | +  |
| D. Conjoin P <sub>2</sub> -NP and XP               | *   | +  | -(-)  | -(-)  | -(-)  | -(-)   |
| E. Omit P <sub>1</sub>                             | *   | +  | +   | +   | +   | -(+)   |
| F. Only P <sub>2</sub> subcategorized              | -(*)  | -(-)   | +   | -(-)  | -(-)  | -(-)   |
| G. Reorder: P <sub>2</sub> -NP-P <sub>1</sub>      | -(*)  | -(*)   | *   | *   | *   | +  |
| H. Insert: P <sub>1</sub> -SPEC-P <sub>2</sub> -NP | *   | +  | -(+)  | -(+)  | -(+)  | -(+)   |
| I. Insert: P <sub>1</sub> -ADV-P <sub>2</sub> -NP  | -(*)  | *  | +   | +   | +   | +  |

Table 3.1.  
Some criteria for the structure of the P-P-NP strings in English

- + - result acceptable
- \* - result unacceptable
- ? - result uncertain
- - criterion not applied
- (-) - criterion not applicable
- (+) - if applied, result acceptable
- (\*) - if applied, result unacceptable

Only criteria A, B, and I were considered by Jackendoff in his investigation. The others, except for D and G, were -- in various combinations -- additionally considered by his earlier critics.

The common feature of these strings is their constituent-like behaviour with respect to preposing. For Jackendoff, this means that they have the P-PP structure. In my view, some of the strings have the specifier-head structure and one is a derived constituent. The difference in the behaviour of these strings are accompanied by semantic variation between them, noted in particular, in connection with the strings with the P-PP and the specifier-head structures. This might be seen as providing some further support for the proposed analyses.

In addition to discussing these matters, I have highlighted the problems that the P-PP structure poses for two proposals that have been advanced about the distribution of phrases: the UCC and the CRP. I shall highlight further problems for the CRP in later discussion.

## NOTES TO CHAPTER 3

1. The other examples of the P-P-NP string in Jackendoff's article are as follows:

- (i) Harpo rode the horse out of the barn. (= J's (12a))
- (ii) *Up into the clouds* shot a riderless broomstick!  
(= J's (13b))
- (iii) *Back from his success in the Faroe Islands* comes  
the star of stage and screen, Frodo Marx! (= J's (13c))
- (iv) *Up to your bedroom* with you, young man! (= J's (14a))
- (v) *Back in the box* with you, Jack! (= J's (14b))
- (vi) The bomb plunged down toward the village. (= J's (20a))

As far as I can see, the string in (i) is like the string in (3.1) in the text, and the others are like those in (3.3)-(3.5). I have selected (3.1)-(3.6) because they are discussed less summarily in Jackendoff's article than the others.

- 2. The marginal examples (3.9b) and (3.9c), and also (3.10a), can be regarded either as ungrammatical, but nevertheless, fairly acceptable or as grammatical but not fully acceptable for non-syntactic reasons. Jackendoff appears to follow the former alternative. In Sub-section 2.3.4. (pp. 79-80), I shall adopt the latter position.
- 3. van Riemsdijk (1978: 58-60) also considers the specifier-head structure in his analysis of Dutch PP's and in a brief reference to English PP's.
- 4. Following Jackendoff's (1973) analysis, Radford (1981: 221-222) and Gazdar et al. (1985: 132-133) regard *out of NP* as an instance of the P-PP structure.
- 5. These are Jackendoff's (1983: 161-162; 1985) terms. Following Jackendoff 1985, I shall use 'Path' and 'Place' with a capital 'P' to refer to phrases with this meaning. See Chapter 7 (pp. 210-219) for some further discussion of the semantics of these strings in a wider context.
- 6. It should be pointed out that there is at least one type of the P-P-NP string that seems to have the P-PP structure but not the Path-Place meaning, e.g.:

- (i) They talked about *between the wars*.

See note 12 to Chapter 7 (p. 225) for further relevant examples.

7. There are two potential interpretations of these sentences, presented schematically in (i) and (ii).

- (i) a. The troops advanced [from [beside the river] and [within the forest]].  
 b. The troops advanced [[from beside the river] and [within the forest]]

- (ii) a. A great howl of pain emerged [from [inside the well] and [under the bushes]].  
 b. A great howl of pain emerged [[from inside the well] and [under the bushes]].

The interpretations in (ia) and (iia) are relevant to our discussion.

8. This argument is taken from Jaworska (forthcoming, Section 2).
9. It seems that some version of the A-over-A Condition (Chomsky 1968: 43-44; 1980: 4) should rule out the structures in (3.31) since we have a PP trace within a PP here. (See Radford (1981: 225) for a similar suggestion.) However, Sag's (1982: 334-335) proposal about a formalization of this intuition has been questioned by Goldberg 1985. Both these authors assume that what look like PP objects of prepositions are bare PP's. van Riemsdijk's (1978: 159-160) account for preposition stranding in terms of the Head Constraint supplemented by the idea that English PP's have a COMP node, which serves as an 'escape hatch' for *wh*-movement (p. 227) also fails to predict the ungrammaticality of (3.31).
10. For the sake of simplicity, I omit the conjunction from this diagram.
11. Both properties are characteristic of the PP's in (ia) and (iia), which are generally regarded as two separate constituents: either PP can be preposed and they can appear in either order in post-verbal position:

- (i) a. They talked *to their father* about politics.  
 b. *To their father*, they talked about politics.  
 c. *About politics*, they talked to their father.  
 d. They talked about politics *to their father*.

- (ii) a. The seminar is *in the library* on Wednesdays.  
 b. *In the library*, the seminar is on Wednesdays.  
 c. *On Wednesdays*, the seminar is in the library.  
 d. The seminar is on Wednesdays *in the library*.

12. Quirk et al. (1985: 669) list *away from* as a complex preposition noting (pp. 674, 678) that it can appear in motional and non-motional sentences. In the former, *away* is said to be optional. The following are their examples (p. 678):

- (i) Ann drove (*away*) *from home*.  
 (ii) Ann is *away from home*.

In this sub-section, I am only considering *away from NP* with the motional verb *race*.

However, the claim about lexical unity of *away* and *from* in (ii) is undermined by the possibility of conjoining *from NP*'s following *away* (cf. conjoined *of NP*'s following *out* in (3.17) above) as in the example in (iii).

- (iii) Ann likes to be *away from home* and *from her daily chores*.

This test cannot be applied to the string in (i) because of the optionality of *away*. However, since *away* in (i) can be preposed, e.g.,

- (iv) *Away* drove Ann *from home*!

it cannot be regarded as part of a complex preposition either.

13. The properties of *down into the darkness* are not illustrated by Jackendoff.
14. Waksberg (p. 5) assumes that specifiers within a phrase are selected by the lexical head of that phrase.  
 Mackenzie (p. 33) also considers the optionality of the first preposition in such strings.
15. For some reason, a non-human point of departure in (3.61a) is preferable in this context.
16. This is a rather vague criterion. The omission of *up* or *down* from (i) could be regarded as causing a 'substantial' change of meaning.

- (i) The aeroplane went { (*up*) } *into the clouds*.  
                                   { (*down*) }

17. Radford (1981: 225) offers a positive judgement of (i), where *from NP* has been fronted on its own.

- (i) *From who* was he running *away*? (= R's (69c), p. 225)

He suggests (p. 225) that in this construction, *away* is a part of the complex verb *run away* and *from who* is a PP complement of this verb. This seems to be a plausible account, where the verb is *run*. Notice, however, that in our example, we have *race*. A question corresponding to (i) with this verb appears to be less acceptable than (i):

- (ii) ? *From who* was he racing *away*?

(ii) would be grammatical if *race* and *away* formed a complex verb but ungrammatical if *away from who* there had the specifier-head structure.

18. The Left Branch Condition requires that no element on the left-hand side branch of a constituent can be extracted from this constituent. Thus, in English, examples like (i) and (ii) are ungrammatical:

- (i) \* *What colour* did you order [ $\bar{N}$  \_\_ flowers]?  
 (ii) \* *How* were they [ $\bar{A}$  \_\_ expensive]?

19. Following Jackendoff (1977: 137-139), I assume that the *wh*-phrases in (3.69) are PP's with *how far* and *how high* as their specifiers.
20. A similar restriction has been independently proposed by Williams (1983a: 303-304) in the form \*X XP (i.e., 'consider as ungrammatical a lexical category X followed by an XP complement'). A somewhat modified version of Hoekstra's Condition is presented by Taraldsen (1984: 245) as the Unlike Category Principle.
21. The *t* in the diagrams in (3.75) stands for the trace left by the moved (or 'raised') subject *John*.
22. [- N] associated with verbs actually assigns Case only if the verbs are transitive, i.e., can take an NP complement (cf. Chapter 8 and 10 for objections such a position). According to Stowell (pp. 42-43), [+ TENSE] assigns Case (to a subject) only if it is accompanied by the feature [+ PAST] or [- PAST]. It is [+ TENSE] alone, however, that counts for the CRP.

## CHAPTER 4

## COMPLEX ADVERBIAL CONSTRUCTIONS IN ENGLISH

4.1. Introduction

In the present chapter, I shall consider the proposal made by Emonds 1976 and Jackendoff 1977 that prepositions can take a clause as their complement in a  $P-\bar{S}$  structure. I shall argue that while this analysis is appropriate for some of their data -- those that contain an easily identifiable preposition and involve *wh*-movement or an overt complementizer -- the authors' case for extending it to all the apparently relevant data is not very strong. However, the case for the alternative, where the constructions in question are  $\bar{S}$ 's rather than PP's is only slightly more convincing. The range of constructions examined here is limited to those involving finite clauses and to a sample of lexical items that introduce them.

The data prompting the analysis are exemplified in (4.1)-(4.4).<sup>1</sup>

- (4.1) a. The students bought the book *before the course started*.  
 b. The students bought the book *before the beginning of the course*.
- (4.2) a. The programme will be shown *after some changes are made*.  
 b. The programme will be shown *after some changes*.

(4.3) a. Tom's lived in this town *since he was a child*.

b. Tom's lived in this town *since childhood*.

(4.4) a. The argument continued *until they ran out of tea*.

b. The argument continued *until the morning*.

In each of these pairs, the constituents in italics have common semantic and functional characteristics: they express temporal relations between an event and a point in time, and they function as adverbials.

I shall refer to constituents like those in (4.1a)-(4.4a) as 'complex adverbial constructions' (CAC's) of the *before*-type. 'Complex' means that they contain a clause and 'adverbial' alludes to their function. Later on, however, I shall discuss other types of complex constructions, some of which will be complements (e.g. *They wondered about why Ann didn't come*). On occasion, I shall continue to refer to constituents like those in (4.1b)-(4.4b) as 'ordinary' PP's.

The initial element in the above CAC's has the form of a preposition, as witnessed by the corresponding examples with ordinary PP's. This suggests that *before*, *after*, etc. in CAC's might also be prepositions and heads of PP's. In traditional grammar, these items in clausal constructions are 'subordinating conjunctions' -- 'complementizers' in the terminology of generative grammar. Alternatively, then, these complex constructions might be regarded as  $\bar{S}$ 's.

The idea that the subordinating conjunctions *before*, *after*, etc. should be classified as prepositions taking a clausal complement is attributed to Klima 1965 by both Emonds (p. 172 n. 5) and Jackendoff (p. 79). It should be noted, however, that Jespersen (1924: 89) also

considers this possibility, but -- as we shall see (pp. 103-105) -- without committing himself to it.

Apart from the  $P\bar{S}$  structure, illustrated in (4.5a) below, and the COMP-S structure in (4.5b), two other analyses of CAC's as PP's have been argued for. One, in Jaworska 1984, involves the P-NP structure (4.5c) and the other, in Jayaseelan 1983, the P-ADVP structure in (4.5d). Within both these analyses, what on the surface appears to be a clausal complement of a preposition is regarded as a clause embedded in a complex phrase.<sup>2</sup>

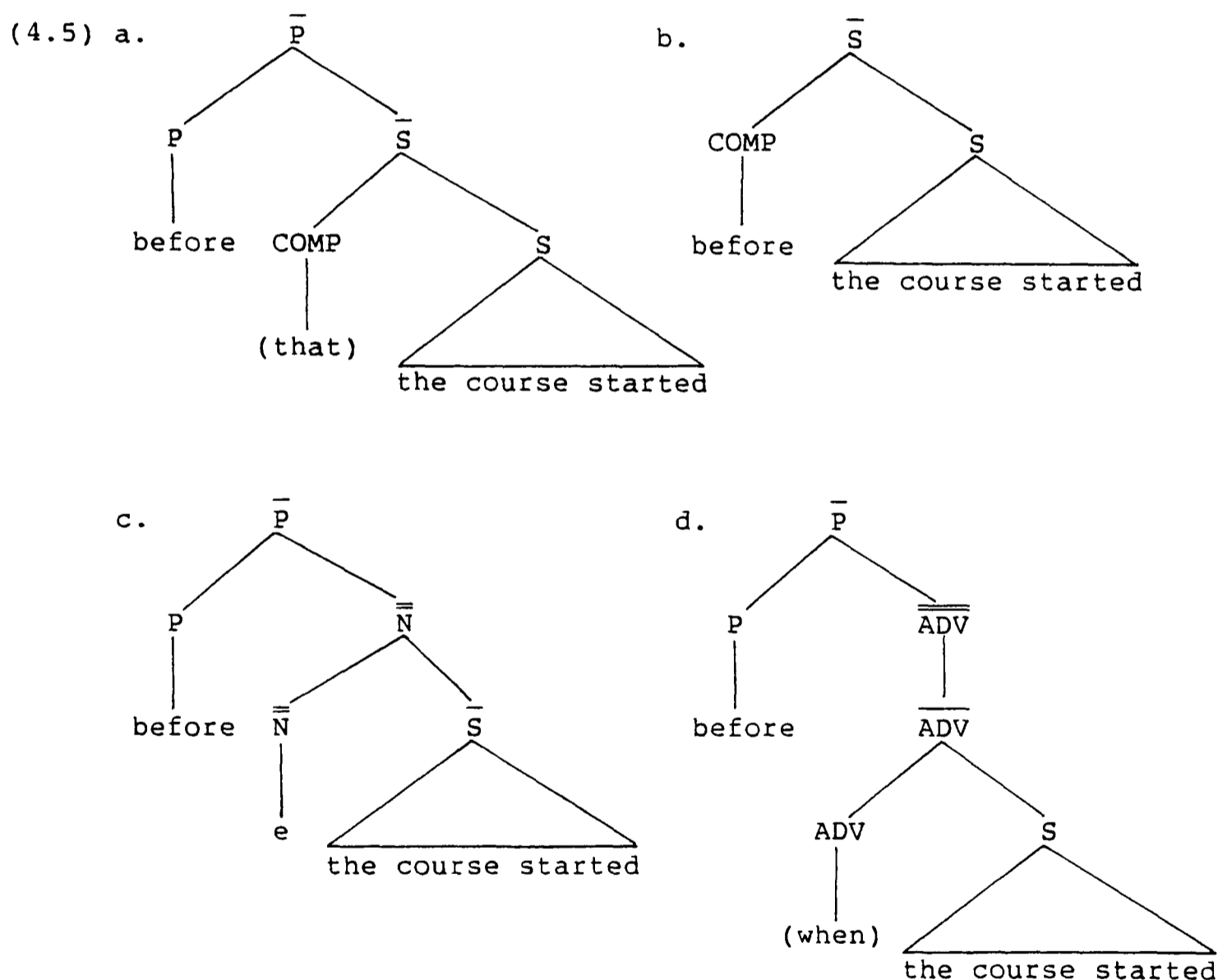

The discussion in this chapter revolves around these structures. In Section 4.2, I summarize the arguments that have been advanced in favour of the analyses embodied in them. I shall note that the original case for the  $P\bar{S}$  structure is not as strong as it has been seen to be. I

shall then develop a critique of the alternative analyses of *before*-type CAC's illustrated by the diagrams in (4.5b)-(4.5d) above. Some of the arguments against these analyses can be seen as further arguments for a  $P-\bar{S}$  analysis. In Section 4.3, I shall propose a slight modification of the  $P-\bar{S}$  structure in (4.5a) for *before*-type CAC's, and then examine other complex constructions. In some cases, e.g.,

(4.6) The twins differ *in that one speaks Irish and the other Welsh*.

the  $P-\bar{S}$  analysis is applicable in a straightforward way. In other cases, however, e.g.,

(4.7) The train was late *because the engine broke down*.

it is not obviously appropriate. A possible alternative might be the COMP-S structure in (4.5b). In Section 4.4, I shall consider Stowell's treatment of the  $P-\bar{S}$  structure, a structure ruled out by the Case Resistance Principle (cf. Chapter 3, p. 86 above). In Section 4.5, I shall sum up the discussion.

## 4.2. Previous analyses

### 4.2.1. PP's with a clausal complement

Emonds' (1976) and Jackendoff's (1977) reasons for distinguishing a sub-class of prepositions that can take a clausal complement arise, again, from their concern with cross-categorial generalizations. In particular, they point out that like verbs, prepositions can take an NP, a PP, or no complement. Since verbs can also take an  $\bar{S}$ , it is to be expected that prepositions can as well. The obvious candidates for such an analysis are the subordinating conjunctions *before*, *after*, etc. and -- by extension -- other subordinating conjunctions such as *because*,

*although*, and *if*. However, they exclude from this classification such clause-introducing items as *that* and *whether*, which they regard as complementizers (cf. Emonds, 172-173, 189; Jackendoff, 33, 79).

Both Emonds and Jackendoff assume that the COMP node is present in the underlying structure of all clausal complements (cf. my note 2 to this chapter). They both assume that this node is normally filled by the complementizer *that* unless it is filled by some other complementizer (e.g. *whether*) or a *wh*-phrase. Where *that* is optional, as it is with most verbs (e.g. *He thought (that) it was raining*), they assume optional deletion of *that*. Thus, in the case of clausal complements of prepositions such as in (4.1a)-(4.4a), Emonds and Jackendoff are forced into the claim that *that* is obligatorily deleted (cf. \**The students bought the book before that the course started*). Jackendoff makes this claim explicitly (p. 79). He proposes the following transformation (p. 102):

(4.8) That-deletion

$[\bar{P} P - \textit{that} - S] \text{ ----> } 1 - \emptyset - 3$   
OBLIGATORY

This deletes *that* from a PP containing a preposition and a clause (S) whenever *that* immediately follows the preposition and immediately precedes the S. In Section 4.3, I shall suggest that it is undesirable and unnecessary to invoke such a transformation.

Emonds (pp. 173-177) brings two properties of CAC's to bear on the idea that they are PP's rather than  $\bar{S}$ 's. One is their occurrence in focus position in cleft sentences, and the other is their co-occurrence with the intensifier *right*.

(4.9) contains two of his examples illustrating the first of these points.

- (4.9) a. It was *after the president had finished* that the  
 disorder began. (from E's (45), p. 174)
- b. It was *because John left* that Mary cried.  
 (from E's (45), p. 174)

Emonds assumes that the occurrence of a constituent in focus position in a cleft sentence is 'a diagnostic in English for the categories NP and PP' (p. 132), and he concludes that clausal adverbials like those in (4.9) are PP's (pp. 173-174), given that they can appear in focus position in a cleft sentence.

However, contrary to a fairly wide-spread belief, expressed in such works as Chomsky (1980: 23), Radford (1981: 110), and Stowell (1981: 24), clefting is not a reliable test for identifying PP's and NP's. Quirk et al. (1985: 547-548, 562, 1385) note that certain ADVP's and AP's can occur in this position. Here are some of their examples:

- (4.10) a. It's *not often* that I have a chance to speak to him.  
 b. It's *all too frequently* that people don't offer to help.  
 c. It's *seldom* that people don't offer to help.  
 d. It was *surgically* that he treated the patient.  
 e. It's *dark green* that we've painted the kitchen.

Pinkham and Hankamer (1975: 433) note examples with finite clauses in this position and infinitives are possible there also. The following illustrate:

- (4.11) a. It was *when they were due* that he was asking.  
 (= P&H's (30))

- b. It's *whether they are fat or not* that he's most concerned about. (= P&H's (31))
- c. It was to attract <sup>the</sup> *neighbour's attention* that she was knocking on the wall.

Given GB assumptions, both types of these constituents are  $\bar{S}$ 's.

Furthermore, as the examples in (4.12) illustrate, not all the clausal constructions that Emonds (p. 175) would analyze as PP's can be clefted. The first example here is from Quirk *et al.* (1985: 1071).

- (4.12) a. \* It's *since they are always helpful* that he likes them.
- b. ?\* It was *although the weather was bad* that the children went to the beach.
- c. \* It's *if you can come* that I'll be pleased.

It is evident from these data that clefting cannot be used to differentiate between PP's and NP's on the one hand, and  $\bar{S}$ 's (and other categories) on the other. In particular, it cannot be used as a test for the category status of CAC's.

In (4.13), we have an illustration of Emonds' second point.

- (4.13) a. They kissed *right after the ceremony*.  
(from E's (47), p. 174)
- b. He came in *right before the party started*.  
(from E's (47), p. 174)

As I noted earlier in Chapter 2 (p. 36), *right*, according to Emonds, can appear as a specifier in ordinary PP's, especially those expressing spatial and temporal location and direction. (4.13b) above illustrates that it can also precede semantically equivalent CAC's. If they are regarded as (temporal) PP's, then -- Emonds (p. 174) suggests -- the

distribution of *right* can be said to be restricted to a single category -- a PP.

This seems to be a generalization broadly along the right lines, as *right* cannot modify a semantically appropriate  $\bar{S}$ . The following illustrates:

(4.14) ?\* I don't know *right when he's coming*.

Unlike clefting, then, an argument for regarding *before*-type CAC's as PP's rather than  $\bar{S}$ 's based on the distribution of *right* is a valid argument. Notice, however, that it is inapplicable to the other types of CAC's, as they are neither spatial nor temporal. Thus, the case for a P- $\bar{S}$  analysis of these CAC's rests solely on considerations of similarities between prepositions and verbs (cf. pp. 99-100 above). In the next sub-section, I shall provide two more arguments for the P- $\bar{S}$  analysis of *before*-type CAC's, and later on, I shall suggest that certain other cross-categorial considerations point towards the COMP-S analysis of some other CAC's.

Before I move on to these matters, let me briefly turn to Jespersen's views on the structure of CAC's and on the category status of their initial elements. In Jespersen 1924, he writes as follows after the examples *after his arrival vs after he had arrived, before his breakfast vs before he had breakfast, and He laughed for joy vs He laughed because he was glad*:

'The so-called conjunction is really ... a sentence preposition: the difference between the two uses of the same word consists in the nature of the complement and in nothing else; and just as we need no separate term for a verb completed by a whole sentence (clause) as distinct from one completed by a substantive, so it is really superfluous to have a separate name for a "conjunction"; if we retain the name, it is merely due to tradition, not to any scientific necessity, and should not make us recognize conjunctions as a "part of speech."' (Jespersen 1924: 89)

This appears to be very like Emonds' and Jackendoff's reasoning described above (cf. pp. 99-100).

Given such a categorical statement, it is rather surprising, then, to find the following passage on *before*, *after*, etc. in Jespersen 1927:

'In "after that (before that) this had happened" *after* and *before* were originally prepositions having the clause with *that* as their object, but now *after that* and *before that* became a kind of composite conjunction, in which *that* was viewed in exactly the same way as in the other combinations mentioned [e.g. *I think (that) he can come, if (that) he can come, though (that) he can come, etc. -- EJ*], and therefore was frequently omitted. In all these cases the insertion of *that* fell more and more into disuse, and is not found in literary style and in educated speech; thus *after*, *before*, *till*, *since* are in this respect placed on the same footing as *if* and *though*: they are, to all intents and purposes, conjunctions, though in other combinations they are prepositions'. (Jespersen 1927: 28)

Here, Jespersen appears to differentiate between prepositions and (subordinating) conjunctions, without a trace of the earlier claim that no distinction should be made between these two categories.

Finally, Jespersen (1937: 152) gives two different formalizations of the sentence in (4.15), a *before*-type CAC.

(4.15) He came *before* I left.

They are presented in (4.16). The explanations of the symbols are from Jespersen (1937: 6-7).

(4.16) a. S V p1(S<sub>2</sub> V)

b. S V 3(3<sup>c</sup> S<sub>2</sub> V)

S is subject

V is finite verb

p is preposition

1 is primary

3 is tertiary

<sup>c</sup> is connective (serving to connect a clause with the principal part of sentence, conjunction, relative pronoun, etc.)

( ) contains particulars serving to explain the item immediately preceding

According to (4.16a), *before* in (4.15) is a preposition taking a clausal complement. According to (4.16b), it is a 'connective'. However, the following remark implies that as a 'connective', *before* is not a preposition:

'The symbol  $3^C$ , the reader may have remarked, does not stand for any particular word-class ...  $3^C$  according to circumstances is a relative adverb or a conjunction ... [When *after* or *before* introduce a clause, we may write them either  $3^C$  like ordinary conjunctions or else as prepositions *p*, but in that case it is necessary to insert *l* as the regimen of the preposition, which is then interpreted by means of the following parenthesis'. (Jespersen 1937: 152)

If (subordinating) conjunctions and prepositions were members of the same category, as is suggested in the first of the passages quoted above, then there should be no need for emphasizing that *before* and *after* can be regarded as one or the other. Thus, it seems that Jespersen is rather ambivalent about the structure of CAC's.<sup>3</sup>

#### 4.2.2. Bare $\bar{S}$ 's

The most attractive alternative to the P- $\bar{S}$  analysis of *before*-type CAC's appears to be the one embodied in the diagram in (4.5b) above, repeated here in (4.17).

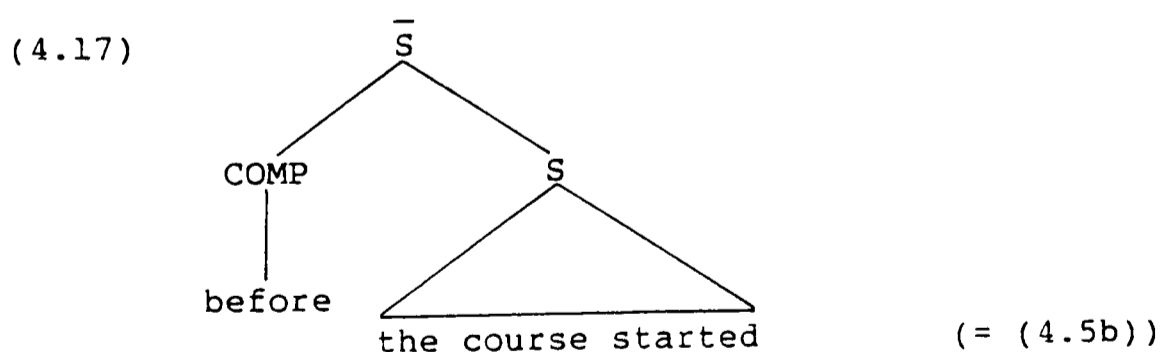

The idea that the preposition-like elements introducing a clause are subordinating conjunctions (or complementizers) is favoured in Quirk *et al.* (1985: 997-998) and -- in direct response to Jackendoff 1977 -- argued for in Hendrick (1976: 116-120). In both these works, *because*, *although*, etc. receive the same treatment.

Hendrick presents three arguments against the  $P-\bar{S}$  structure and in favour of the COMP-S structure. One is concerned with the impossibility of extraction out of CAC's, another with the distribution of sentence adverbials like *hopefully*, and the third with the non-occurrence of *that* following the CAC-initial element, i.e. the ungrammaticality of sequences like *\*before that S* and *\*because that S*. All these arguments are reviewed at length in Jaworska (1984: 256-263), where it is argued that Hendrick has no case against the  $P-\bar{S}$  analysis.

While I still maintain my objections to the first two of these arguments, I now think that the non-occurrence of strings like *\*because that S* (but not *\*before that S*) might be regarded as some evidence against the  $P-\bar{S}$  analysis of such CAC's (cf. p. 131 below).

I shall now develop two new arguments against the COMP-S analysis of *before*-type CAC's. One is prompted by examples like (4.18), which would have to be analyzed as involving two successive complementizers.

(4.18) a. The applause lasted *until after the pubs closed*.

b. He's been working *since before the match began*.

The other argument has to do with the case marking of the subject of the adverbial clause. To make these arguments explicit, I shall refer to some concepts of the GB framework.

If one is not prepared to contemplate the  $P-\bar{S}$  structure, one must analyze not just *after* and *before* in (4.18a) and (4.18b) but also *until* and *since* as complementizers. If the latter were prepositions, these strings would be instances of the  $P-\bar{S}$  structure. Thus, we must consider the viability of a COMP- $\bar{S}$  structure.

It was noted in Chapter 1 (pp. 17-18) that two formalizations of the  $S/\bar{S}$  structure have been considered within GB. They are repeated in (4.19).

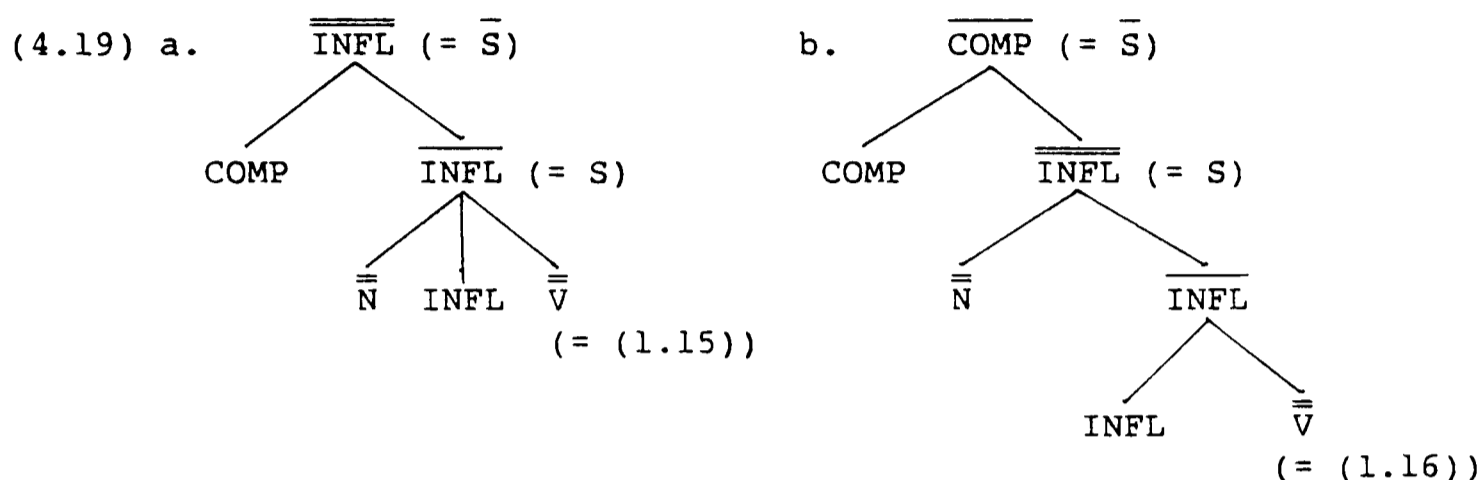

Given these possibilities, the CAC in (4.18a), for example, would have one of the following structures:

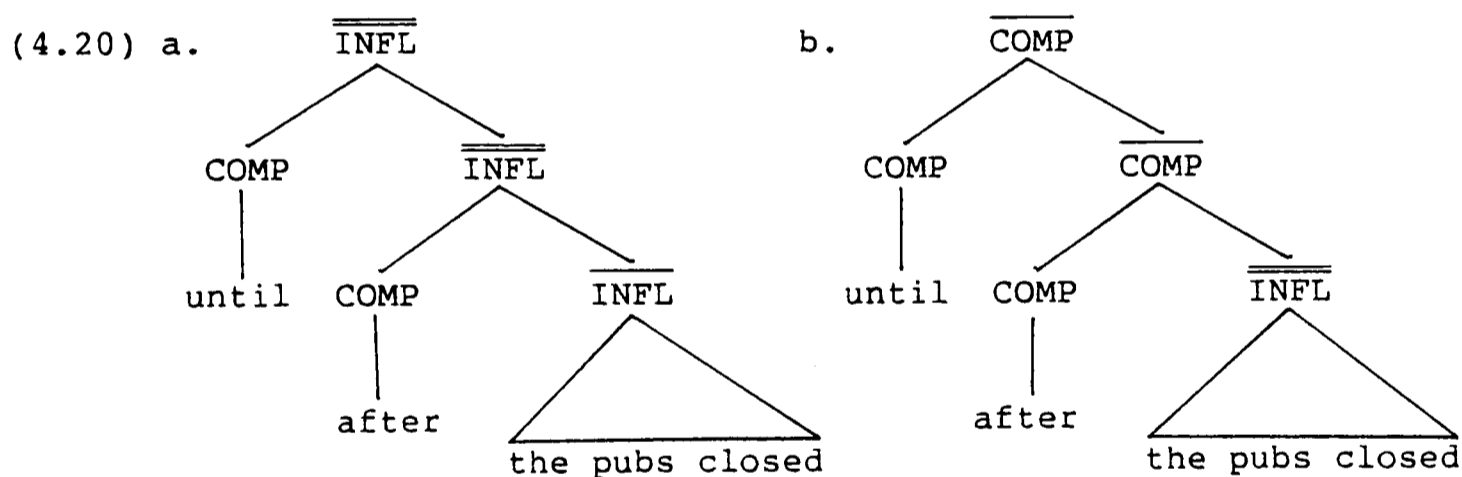

The former is unsatisfactory because the higher COMP is a specifier whose sister is a maximal projection. Normally, however, the sister of a specifier is an  $\bar{X}$  (cf. Chapter 1, pp. 15-16 above).

On the face of it, the other structure seems more plausible. Here, the higher COMP is a head, which takes  $\overline{\text{COMP}}$  -- the maximal projection of COMP -- as its complement. Notice, however, that the lower COMP takes  $\overline{\overline{\text{INFL}}}$  as its complement and this is the category that all the other complementizers take. If *until* (and *since*) in our examples were complementizers that could take either  $\overline{\text{COMP}}$  or  $\overline{\overline{\text{INFL}}}$  as a complement,

then we would expect them, or some other complementizers, to take other maximal projections as complements as well.

The examples in (4.21) appear to be relevant in this regard.<sup>4</sup>

- (4.21) a. *While in Nepal*, he fell in love with a Yeti.  
 b. *Although a victim of considerable persecution*,  
     Alphonse generally remained cheerful.  
 c. *Whether young or old*, you will enjoy the play.

Here, we have complementizers followed by a (predicative) PP, NP, and AP, respectively. Given GB assumptions, these constructions will be 'small clauses', constituents with a subject and a predicate but with no verb. The subject will be PRO, a phonologically unrealized category coreferential with the subject of the main clause (cf. Chapter 3, p. 67 above). Similar constructions in sentences like *John emerged from the meeting [PRO confused by their reaction]* have been discussed by Stowell (1981: 263-265) and referred to by Chomsky (1981: 111).

To claim that complementizers can take a full range of maximal projections as their complements, and hence that the structure in (4.20b) is well-motivated, it would have to be shown that the italicized phrases in (4.21) are instances of a complementizer followed by an XP, XP ≠ S. For example, it would have to be shown that the phrase in (4.21a) has the structure in (4.22).

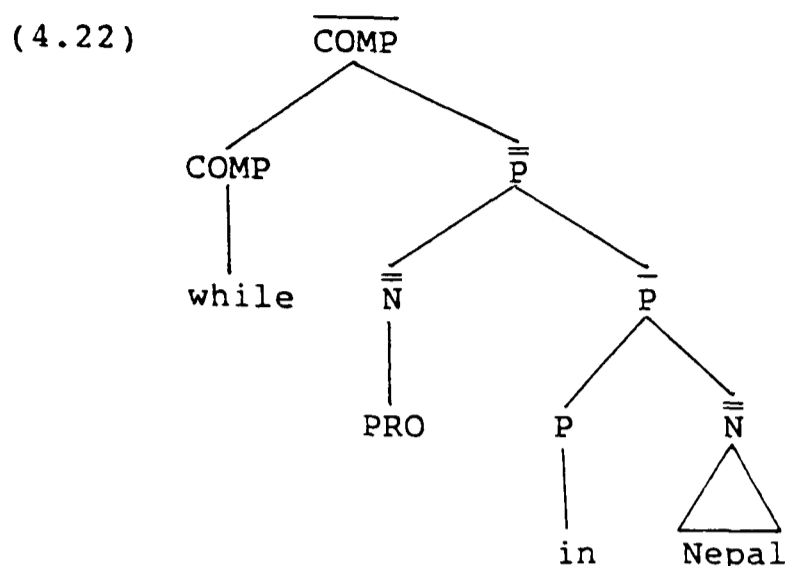

Here, COMP is followed by a small clause PP, whose head is a preposition, the head of the predicative phrase. In the other examples in (4.21), *although* and *whether* would, respectively, be followed by an NP and an AP small clause.

The idea that some small clauses are constituents, projections of their predicates, has been advanced by Stowell (1981: 257-258). He points out, however, that small clauses whose subject is PRO are S's rather than XP's (1981: 265) since one of the properties of PRO is that it cannot be governed (cf. Chomsky 1981: 191).

According to the definition of government (cf. Chapter 1, p. 21 above), for a category *x* to govern a category *y*, the former must be a lexical category and both must be dominated by exactly the same maximal projections. Possible governors include all the main lexical categories, INFL (when it bears the feature complex AGR, i.e. in finite clauses), and the complementizer *for* in English.

In structure (4.22), PRO is governed by the preposition *in*, since *in* is a lexical category and both *in* and PRO are dominated by exactly the same maximal projections (i.e.  $\bar{P}$  and  $\overline{\text{COMP}}$ ). Thus, (4.22) is not a viable representation of the phrase in (4.21a). The analogous COMP-NP and COMP-AP structures associated with the *although*- and *whether*-phrases in (4.21b) and

(4.21c), respectively, must likewise be rejected.

The alternative to (4.22) is the structure in (4.23), where the complementizer is followed by an  $\overline{\overline{\text{INFL}}}$  (i.e. S) complement.

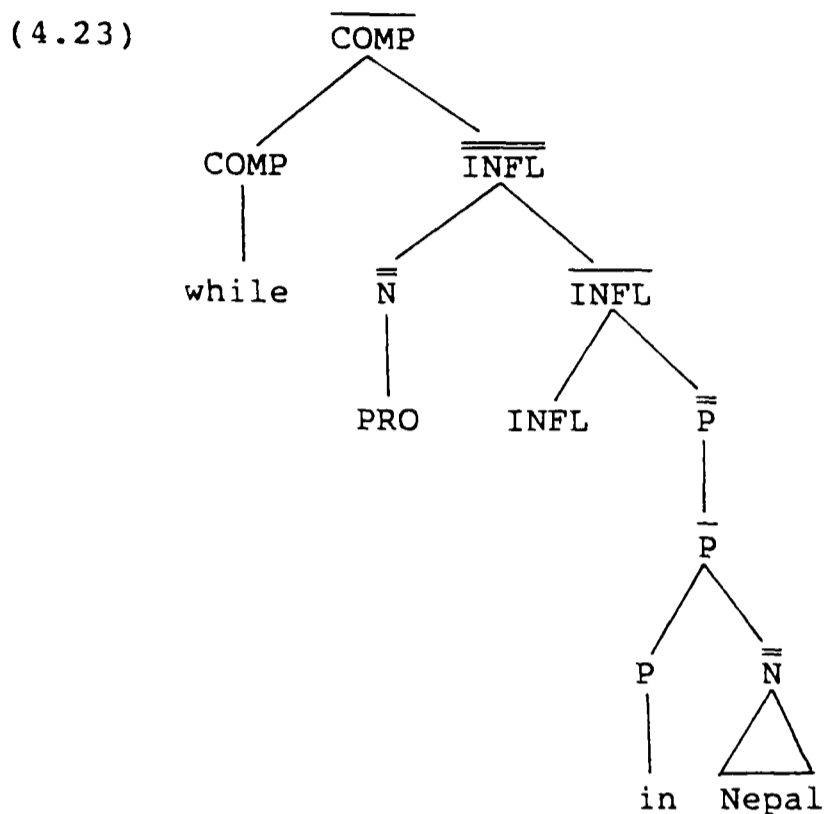

Here, as required, PRO is ungoverned: the preposition does not govern PRO because it is dominated by a maximal projection ( $\overline{\overline{\text{P}}}$ ) which does not also dominate PRO; INFL does not govern it because, heading a non-finite clause, it has no AGR; and *while* does not govern PRO because it is not the type of complementizer that is a possible governor.

Given these considerations, the data in (4.21) do not provide evidence for the idea that complementizers can select a complement from a range of maximal projections, which would include  $\overline{\overline{\text{COMP}}}$  as in (4.20b) above. On the contrary, these data strengthen the case for regarding  $\overline{\overline{\text{INFL}}}$  (i.e. S) as the only possible complement of a complementizer.

No comparable problems arise if we assume that the preposition-like items in (4.18) are prepositions. Then, the CAC's are simply PP's with the P-PP structure discussed in the previous chapter, with the lower PP consisting of a preposition and an  $\overline{\overline{\text{S}}}$  complement,  $\overline{\overline{\text{INFL}}}$  or  $\overline{\overline{\text{COMP}}}$ , depending on the choice of the  $\text{S}/\overline{\overline{\text{S}}}$  structure in (4.19) above.

Leaving the content of the COMP node aside for the moment (but see p. 125 below), these CAC's have one or the other of the following structures:

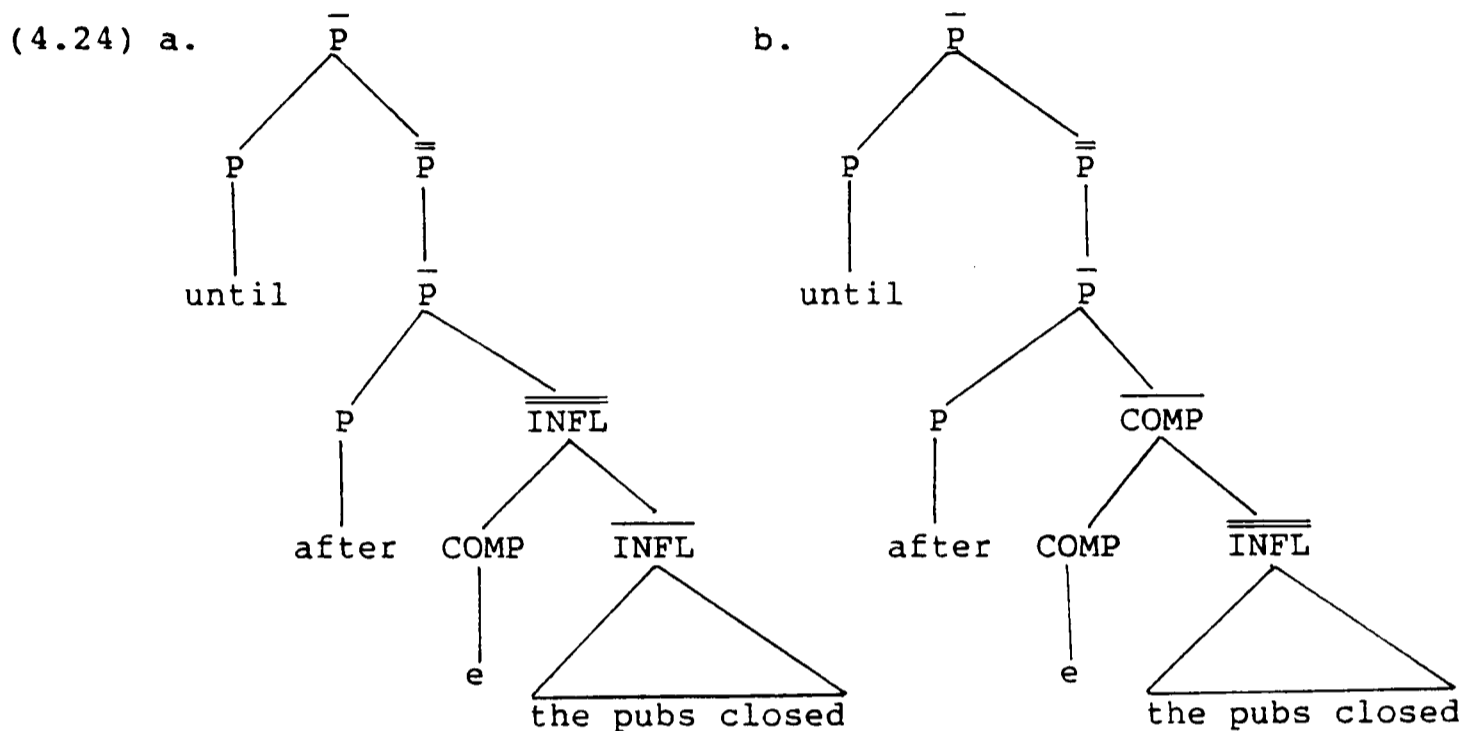

It should be noted for the sake of completeness that since the original advocates of the  $P-\bar{S}$  structure consider subordinating conjunctions like *while* and *although* (but not *whether*) as prepositions (cf. pp. 99-100 above), they would presumably favour a  $P-\bar{S}$  structure like (4.25) for the phrases *while in Nepal* and *although a victim of considerable persecution in* (4.21b) and (4.21c), respectively.

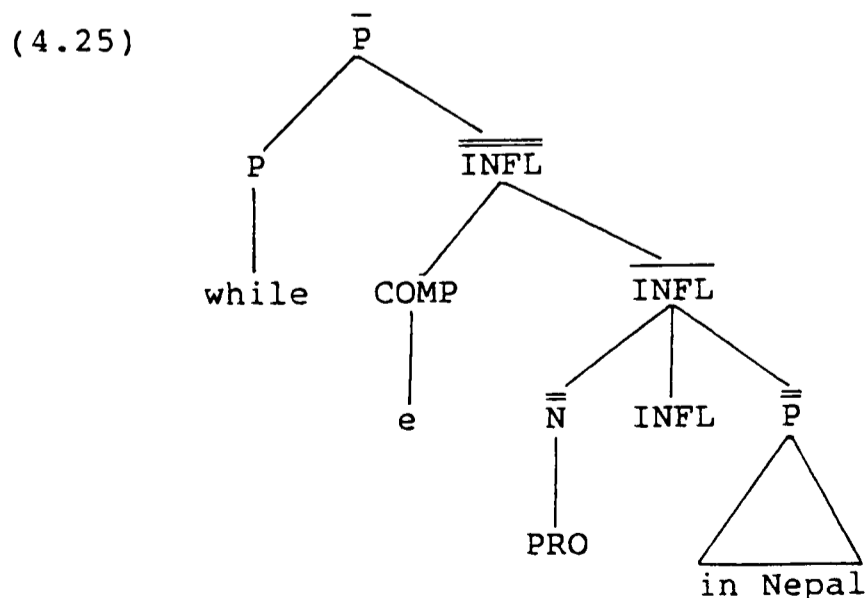

PRO here would not be governed by the preposition <sup>in</sup> for the same reason as in (4.23) above and it would

not be governed by *while* (even if it were a possible governor) because PRO and *while* are not dominated by the same maximal projections. Notice that since (4.23) and (4.25) make the same correct predictions about the grammaticality of the constructions under consideration, the data in (4.21) do not seem to provide any arguments for the choice between one of these structures.

Let us now turn to the other objection to the COMP-S structure, arising from the case marking of the subject NP in CAC's. Here, I shall refer to the GB Case assignment mechanism (cf. Chapter 1, p. 22). This argument pertains to either conception of the  $S/\bar{S}$  structure depicted in (4.19) above. I choose (4.19a) for the purpose of illustration.

The following example shows that the subject NP in CAC's is nominative:

(4.26) We left before *they* exploded.

If *before they exploded* were an  $\bar{S}$ , its structure would be comparable to that of the infinitival clause in the following sentence:

(4.27) We arranged *for them to be exploded*.

Both structures are presented in (4.28), with the lexical items in their surface form.

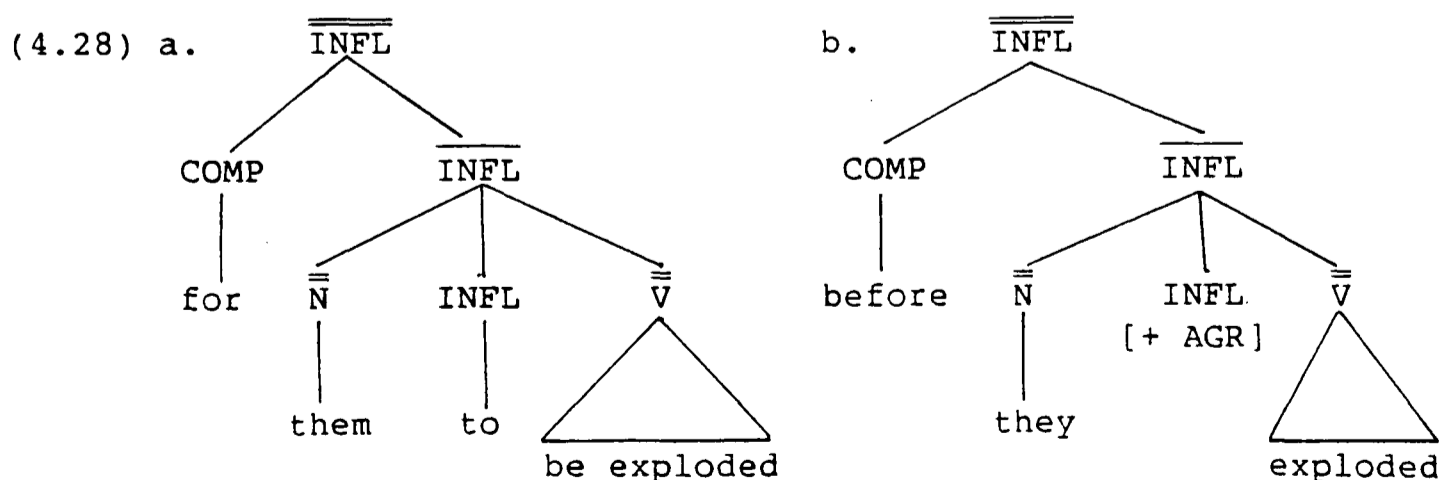

In (4.27a), *for*, a 'prepositional complementizer' (cf. Chapter 1, p. 22

above), retains its prepositional properties of being a governor and the assigner of objective Case. Since it governs the subject NP in the following clause, it assigns objective Case to it. Hence, we have *them*, and not the nominative form *they* in (4.26) above.<sup>5</sup>

Now, since *before*, *after*, etc. are prepositions elsewhere, they would -- like *for* -- be prepositional complementizers in CAC's if they appeared in COMP position as in (4.28b). If this were so, the subject of the clause -- governed here by *before* -- should receive objective Case from it as well as nominative Case from the governing INFL[+AGR]. With the NP assigned two conflicting Cases, (4.26) should not be a grammatical sentence.

To eliminate this prediction, we must prevent *before* from governing this NP. The obvious alternative to (4.28b) is the P-S structure, given in (4.29).

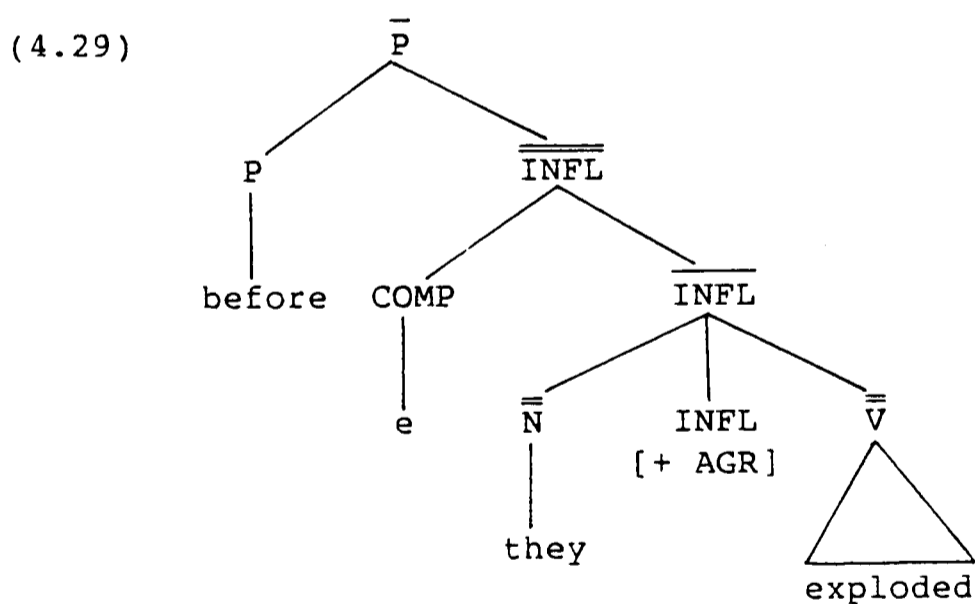

Here, only INFL[+AGR] but not *before* governs the subject because *before* and *they* are not dominated by the same maximal projections. Thus, only nominative Case is assigned to the subject.

Once again, then, technical considerations lead us to favour the

$\bar{P}$ - $\bar{S}$  analysis over the COMP-S analysis of *before*-type CAC's.

#### 4.2.3. PP's with a complex NP complement

We turn next to an analysis of these constructions where they are PP's consisting of a preposition followed by a complex NP rather than by a bare clause. This is the analysis illustrated in (4.5c), repeated here in (4.30)

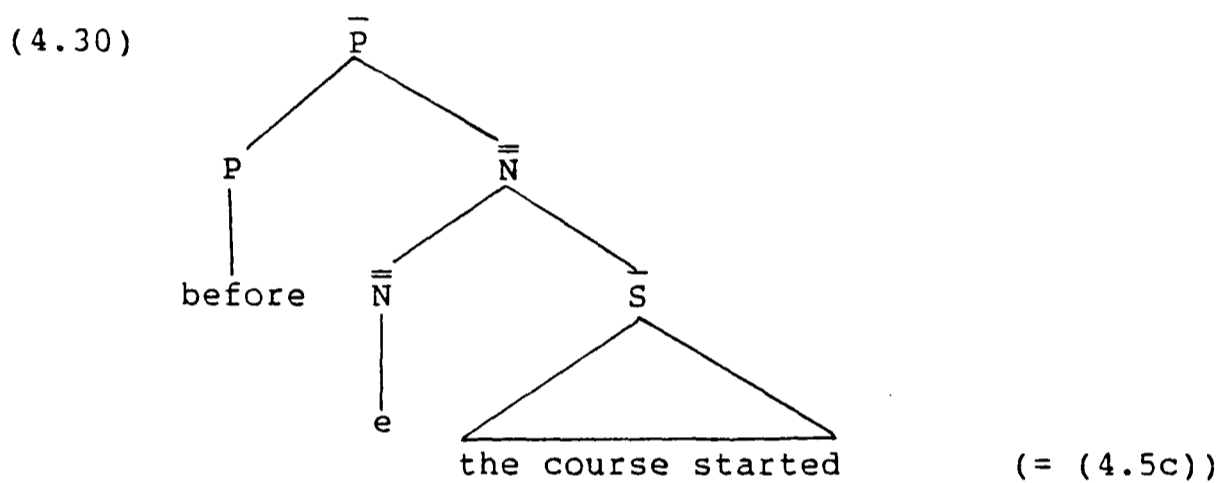

This was tentatively proposed in Jaworska (1984: 265) on the basis of two considerations: the impossibility of extraction out of CAC's and certain paraphrase relations holding between *before*-type CAC's and relative constructions. It was argued that this analysis was preferable not only to Hendrick's COMP-S analysis but also to Jackendoff's  $\bar{P}$ - $\bar{S}$  analysis. I now believe that the arguments are not compelling.

My first argument was based on an example like (4.31).

(4.31) \* What did Tom arrive *before* Ann saw \_\_\_?

I considered the possibility of accounting for this unacceptability in terms of the 'Subjacency' condition (Chomsky 1973: 247-248). This requires that movement rules cannot operate across more than one 'bounding node'.

If CAC's were PP's with a complex NP complement, (4.31) would have the structure indicated in (4.32) and it would be ruled out by Subjacency. The arrows mark the successive applications of *wh*-movement.

(4.32)

$$[\text{COMP} \text{What}_i] [\text{S} \text{did Tom arrive} [\bar{\text{P}} \text{before} [\bar{\text{N}} \text{e} [\bar{\text{S}} [\text{COMP} t_i] [\text{S} \text{Ann saw } t_i]]]]]]?$$

On the first application of *wh*-movement, the *wh*-element is moved from the object position to the nearest COMP, and on the second application, it is moved to the next COMP, leaving a trace in each case. As there is only one S-boundary between the two traces, Subjacency is not violated on the first cycle. On the second cycle, however, the *wh*-element crosses two bounding nodes, NP and S, in violation of the condition. Therefore, (4.31) is ungrammatical.

If CAC's were PP's with a bare  $\bar{\text{S}}$  complement, and if NP and S were the only possible bounding nodes, Subjacency -- I argued -- could not be invoked to account for (4.31). The relevant aspects of the structure and the movement involved would be as indicated in (4.33).

(4.33)  $[\text{COMP} \text{What}_i] [\text{S} \text{did Tom arrive} [\bar{\text{P}} \text{before} [\bar{\text{S}} [\text{COMP} t_i] [\text{S} \text{Ann saw } t_i]]]]]?$

Here, on both cycles, *wh*-movement would be crossing only one bounding node, S. The attraction of the P-NP analysis seemed to be that it provided an additional bounding node, NP, so that (4.31) could be ruled out by Subjacency.

However, I was wrong in assuming that the choice of NP and S as bounding nodes in English was fixed for all relevant constructions. In fact,  $\bar{\text{S}}$  can sometimes be added to the stock of bounding nodes. For example, the contrast between (4.34a) and (4.34b),

- (4.34) a. Who did you say that Tom saw \_\_\_?  
 b. \* Who did you *murmur* that Tom saw \_\_\_?

is accounted for by regarding  $\bar{S}$  as a bounding node if  $\bar{S}$  is a complement of a certain class of verbs -- 'manner of speaking' verbs (cf. Chomsky 1977: 85; 1980: 15). As illustrated in (4.35), both these examples have identical structures.

- (4.35) a. [COMP $Who_i$ ][ $S$ did you say[ $\bar{S}$ [COMP $t_i$  that][ $S$ Tom saw  $t_i$ ]]]?  
 b. [COMP $Who_i$ ][ $S$ did you murmur[ $\bar{S}$ [COMP $t_i$  that][ $S$ Tom saw  $t_i$ ]]]?

In (4.35a), only  $S$  is a bounding node and Subjacency is not violated. In (4.35b), both  $S$  and  $\bar{S}$  are bounding nodes. As they both intervene between the *wh*-element in the higher COMP and the trace in the lower COMP, Subjacency is violated and (4.34b) is ungrammatical.

We can return now to the example in (4.31) and its structure in (4.33). It is easy to see that with the flexibility in the choice of bounding nodes we can, after all, account for the unacceptability of this question by invoking Subjacency and retaining the  $P-\bar{S}$  structure. This simply requires that we assign to the  $\bar{S}$  in (4.33) the status of a bounding node. Specifically, we can stipulate that  $\bar{S}$  is a bounding node when it is the complement of a preposition, just as it is stipulated for those  $\bar{S}$ 's that are complements of manner of speaking verbs. Looking back at (4.33), we could now draw a broken line across the  $\bar{S}$ . With the *wh*-element crossing two bounding nodes on the second cycle, Subjacency is violated.<sup>6</sup>

My other argument (p. 226) for the P-NP structure was based on paraphrase relations between pairs like the following:

- (4.36) a. Bill arrived *before John hit Mary*. (= J's (3.13a))  
 b. Bill arrived *before the time at which John hit Mary*.  
 (= J's (3.13b))

I suggested that since these sentences were synonymous, they should have similar structures.<sup>7</sup> Since the structure associated with the more elaborate adverbial in (4.36b) would be P-NP, illustrated in (4.37) below, the structure associated with the CAC in (4.36a) should also involve a complex NP, something like (4.30) above.

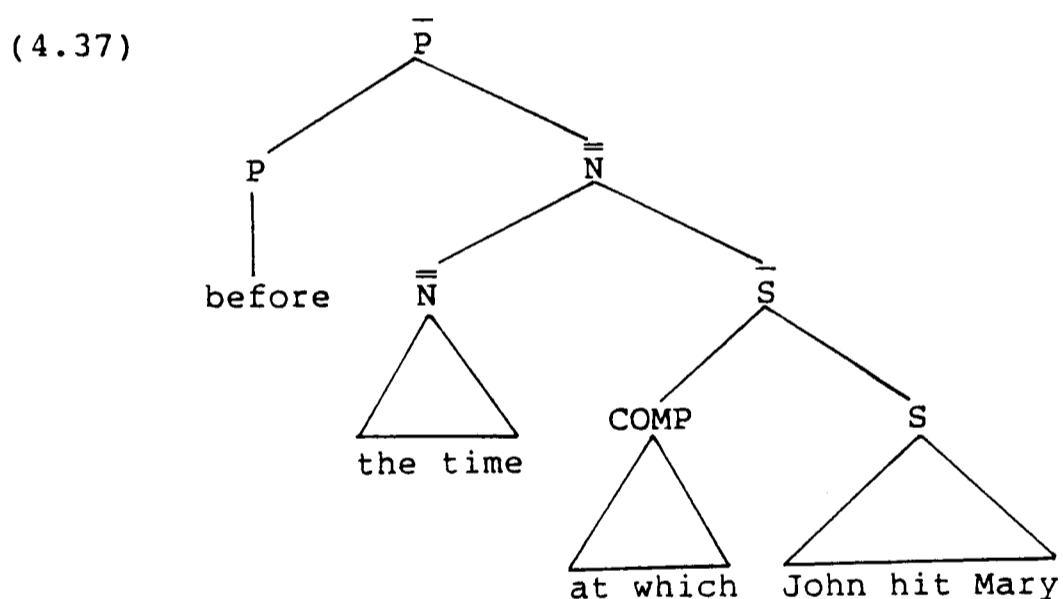

I then suggested that (4.30) could be either derived transformationally from (4.37) through deletion of *the time at which* or base-generated with an empty NP head.<sup>8</sup>

Obviously, an argument about the structure of constituents based on such paraphrase relations is not very strong and it certainly could not be accepted as the only argument for this analysis. There is no more reason for assigning the P-NP structure to both adverbials in (4.36) on the basis of such paraphrases than there would be for assigning identical structures to the italicized phrases in (4.38) just because

they are paraphrases of each other (cf. Chapter 3, pp. 65 ff.).

- (4.38) a. He emerged *from inside the house*. (= (3.19c))  
 b. He emerged *from a place inside the house*. (= (3.24))  
 c. He emerged *from a place which was inside the house*.  
 (cf. (3.25))

It turns out, then, that neither of my previous arguments against the  $P\bar{S}$  structure is of any value.

There is, however, one positive feature of my analysis highlighted by the possibility of paraphrase of *before*-type CAC's with a relative clause construction. This is the implicit suggestion that these CAC's, like relative clauses, might involve *wh*-movement. In the next sub-section, there will be an opportunity to expand on this idea.

#### 4.2.4. PP's with a free relative complement

Jayaseelan 1983 develops an analysis of *before*-type CAC's involving the last of the structures in (4.5), repeated here in (4.39). The analysis is advanced in reply to Jackendoff's  $P\bar{S}$  analysis.

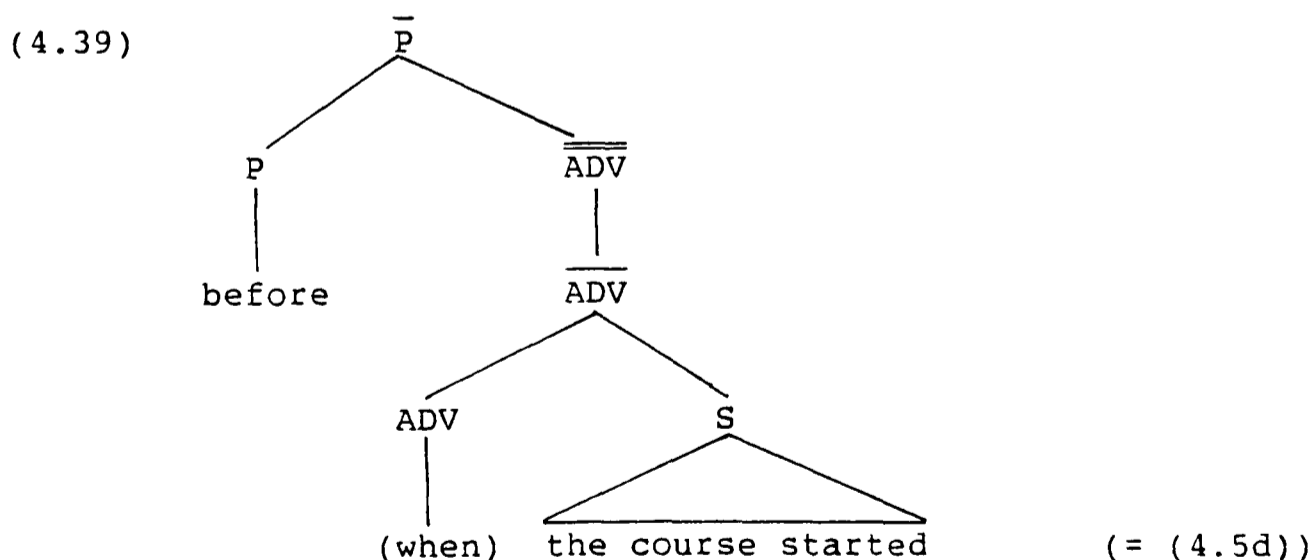

Here, CAC's are PP's whose complement is a type of relative construction, the so-called 'free relative'. This can be described as a relative clause construction with the relativized constituent missing (cf. *before (the time) when the course started*). Jayaseelan adopts

Bresnan and Grimshaw's (1978) conception of the structure of free relatives, but he regards *when* as an adverb whereas they label it as nominal (1978: 347).

According to Jayaseelan (p. 431), *when* undergoes obligatory deletion, which explains why it can never occur on the surface, e.g.:

- (4.40) \* I arrived there before *when* Mary arrived there.  
 (= J's (13))

This account is unsatisfactory for empirical and theoretical reasons.

First of all, Jayaseelan's judgement about (4.40) is misleading. Although not standard, such sentences are acceptable for some speakers, and they improve greatly with the indefinite particle *-ever* attached to *when*. In (4.41), *when* is present in a CAC introduced by *since* and in (4.42), we have examples with *whenever*.

- (4.41) I've had this gem since *when* I was a child.

- (4.42) a. I arrived there before *whenever* Peter arrived there.  
 b. The message was delivered after *whenever* it was that  
 the building collapsed.

Given the acceptability of these examples, one might think of *when*-deletion as optional rather than obligatory.

Secondly -- obligatory or optional -- *when*-deletion would make free relatives in the complement of *before*, *after*, etc. unlike other free relatives because elsewhere, *when* and other *wh*- $\int$  words must be present on the surface. The following illustrate:<sup>9</sup>

- (4.43) a. The garden looks different now from \*(*when*) you last  
 saw it.

- b. The application must be submitted by \*(when) the committee meets.

Finally, as I have already pointed out (Chapter 3, p. 66, and note 8 to this chapter), deletion of specific lexical items is a type of syntactic operation not permitted within current grammatical theory.

Given these considerations, the analysis embodied in (4.39) is not viable.

A more valuable feature of Jayaseelan's contribution is that it provides evidence that clauses introduced by *before*, *after*, etc. must be analyzed in terms of *wh*-movement, given GB assumptions. Because I find Jayaseelan's discussion of these matters more complex than it need be, below I depart somewhat from the original.<sup>10</sup>

A relevant example to begin with is the following:

- (4.44) Adam was in bed before [ $\bar{S}$  Ann said [ $\bar{S}$  that he would be in bed]].

As indicated by the labelled brackets, the clause following *before* contains a subordinate clause. The sentence has two meanings: one expressing a temporal relation between the time that Adam was in bed and the time that Ann talked about it; and the other expressing a temporal relation between the time that Adam actually was in bed and the time that he was said by Ann to be in bed.<sup>11</sup>

However, when the final clause in (4.44) is embedded within an NP, the sentence is unambiguous:

- (4.45) Adam was in bed before [ $\bar{S}$  Ann made [ $\bar{N}$  the claim [ $\bar{S}$  that he would be in bed]]].

This can only be interpreted as expressing a temporal relation between

the time that Adam was in bed and the time that Ann talked about it. The same is true of the next example, (4.46), where the final clause in (4.44) is a *wh*-clause.

(4.46) Adam was in bed before [ $\bar{S}$  Ann asked [ $\bar{S}$  why he would be in bed]].

We find the same pattern with *wh*-questions. Like (4.44), (4.47) is ambiguous.

(4.47) When did Ann say [ $\bar{S}$  that Adam would be in bed]?

It can be taken as questioning the time of Ann's saying something or the time that Adam would be in bed according to Ann. However, when the subordinate clause in (4.47) is within an NP or is a *wh*-clause, the ambiguity disappears. In this respect, (4.48) and (4.49) are comparable to (4.45) and (4.46), respectively.

(4.48) When did Ann make [ $\bar{N}$  the claim [ $\bar{S}$  that Adam would be in bed]]?

(4.49) When did Ann ask [ $\bar{S}$  why Adam would be in bed]?

In neither of these examples can *when* be taken to question the time that Adam would be in bed.

Before drawing a conclusion from these data, I present examples with CAC's introduced by *after*, *since*, and *until*, displaying the same pattern of interpretation as (4.44)-(4.46).

(4.50) a. Adam was in bed after [ $\bar{S}$  Ann said [ $\bar{S}$  that he would be in bed]].

b. Adam was in bed after [ $\bar{S}$  Ann made [ $\bar{N}$  the claim [ $\bar{S}$  that he would be in bed]]].

c. Adam was in bed after [ $\bar{S}$  Ann asked [ $\bar{S}$  why he would be in bed]].

(4.51) a. Adam has been in bed since [ $\bar{S}$  Ann said [ $\bar{S}$  that he would be in bed]].

b. Adam has been in bed since [ $\bar{S}$  Ann made [ $\bar{N}$  the claim [ $\bar{S}$  that he would be in bed]]].

c. Adam has been in bed since [ $\bar{S}$  Ann asked [ $\bar{S}$  why he would be in bed]].

(4.52) a. Adam was in bed until [ $\bar{S}$  Ann said [ $\bar{S}$  that he would be in bed]].

b. Adam was in bed until [ $\bar{S}$  Ann made [ $\bar{N}$  the claim [ $\bar{S}$  that he would be in bed]]].

c. Adam was in bed until [ $\bar{S}$  Ann asked [ $\bar{S}$  why he would be in bed]].

Given the above similarities between *before*-type CAC's and *wh*-questions, and the fact that -- within a transformational framework -- the latter involve *wh*-movement, we can conclude that the former, like the various constructions discussed in Chomsky (1977: 86 ff.), involve a type of *wh*-movement.

Given GB assumptions, the *wh*-element in *before*-type CAC's will be a phonologically empty 'operator' (Chomsky 1982: 30-32). Such operators appear elsewhere in the grammar. For example, in the sentence *The men are too stubborn to talk to*, there is a gap following the preposition *to*, which -- according to Chomsky (1982: 31-32) -- is a trace left by an empty operator *0*. The structure in (4.53) is based on Chomsky's (p. 31).

(4.53) The men are too stubborn [ $\bar{S}$  [COMP  $O_i$ ][ $\bar{S}$  PRO to talk to  $t_i$ ]].  
 (cf. Ch's (43))

In the next section (p. 125), I shall return to this idea.

#### 4.3. PP's with a clausal complement revisited

##### 4.3.1. The simple cases

Having strengthened the case for the P- $\bar{S}$  structure for *before*-type CAC's, I shall now proceed to consider some further questions that arise in connection with this structure, and to examine the scope of the analysis.

Let us first recapitulate Emonds' and Jackendoff's version of this analysis, which involves structure (4.5a), repeated here in (4.54).

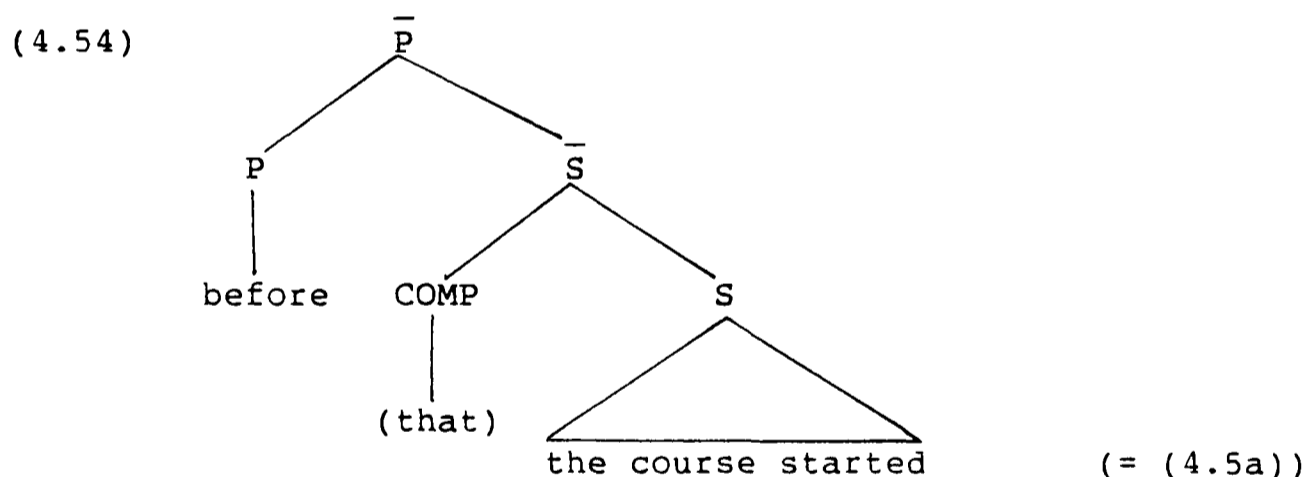

As was mentioned earlier (pp. 99-100), they both assume this structure for all types of subordinate clause except those introduced by straightforward complementizers, and they are both committed to the obligatory deletion of *that* following a preposition. I shall look more closely at the first of these two points in Sub-section 4.3.3. Here, I shall raise two objections to the second point.

One objection is -- as in similar cases previously -- that deletion of arbitrary lexical material is undesirable in principle. The other objection is that the rule, as formulated by Jackendoff (cf. (4.8), p. 100 above) predicts that there are no prepositions followed by a 'full' *that*-clause, i.e., a clause with an overt *that*. As will be shown in the next sub-section, this prediction is incorrect.

In view of this, I suggest that *before*-type CAC's are PP's whose clausal complement does not contain a lexical complementizer in the underlying structure.

Special requirements on the contents of COMP are not without precedence. First, certain verbs can be followed by clausal complements with COMP realized in a specific way. For example, the verb *wonder* requires *whether* but disallows *that*. The following illustrates:

(4.55) They wondered  $\left\{ \begin{array}{l} \textit{whether} \\ * \textit{that} \end{array} \right\}$  anybody was coming.

It also allows a *wh*-phrase to fill the COMP node in indirect questions, following *wh*-movement:

(4.56) They wondered  $\left\{ \begin{array}{l} \textit{why} \\ \textit{when} \end{array} \right\}$  anybody was coming.

Secondly, with certain verbs, COMP in non-finite complements must be empty:

(4.57) a. \* The postman knows *for the family to be on holiday*.  
 b. The postman knows *the family to be on holiday*.

Such variations have been attributed to subcategorization (cf. Stowell 1981: 389). We can say, then, that the prepositions *before*, *after*, *since*, and *until* subcategorize for an  $\bar{S}$  with no overt complementizer.

Some motivation for a COMP node in these structures is provided by the fact that they involve *wh*-movement (cf. p. 122 above), which is movement to the COMP position. As I have noted, the moved element is a phonologically empty operator *O*. In view of this, the structure of *before*-type CAC's given in (4.54) above should be revised as in (4.58), where *O* is coindexed with its trace *t* in adverbial position.

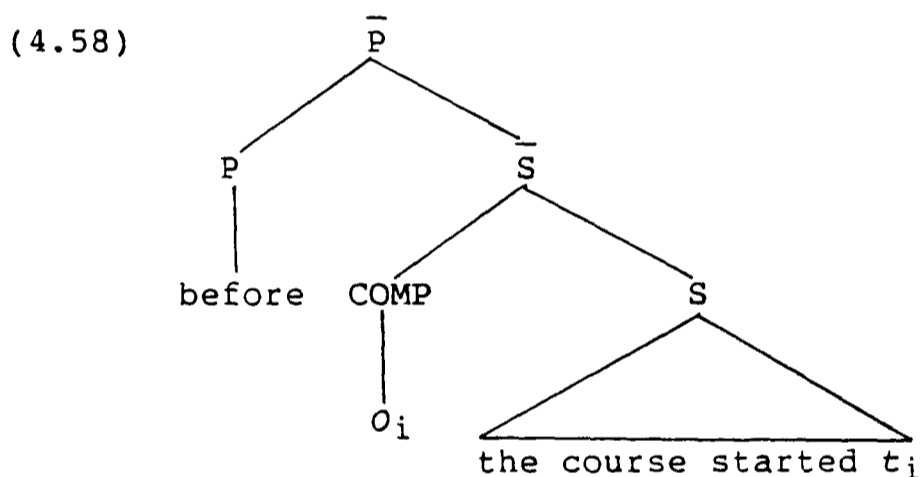

This structure captures the *wh*-movement characteristics of these CAC's without invoking deletion of a *wh*-element. However, it makes this class of prepositions unlike any verb, because there seem to be no verbs in English that take an  $\bar{S}$  complement, whose COMP is filled with the phonologically empty operator *O*.

#### 4.3.2. Some obvious extensions

While *before*-type CAC's have the  $P\bar{S}$  structure with a phonologically empty COMP, there are others, where COMP must or can be lexical, and which, therefore, are the most transparent cases of this structure. Superficially, these constructions fall into two categories, exemplified in (4.59) and (4.60). (4.59a) and (4.60a) come from Emonds

1976.

(4.59) a. They are unwise *in that they are trying to escape*.  
 (from E's (44), p. 173)

b. It'll be good if you could come *except (that) you shouldn't bring your wife*.

c. *Considering (that) their evidence compromises the Prime Minister*, he looks very relaxed.

(4.60) a. Mary questioned them *on whether they had been home*.  
 (E's, p. 183 n.8)

b. They wondered *about why Ann didn't come*.

c. I'm not quite certain *of what he said*.

In (4.59), we have CAC's introduced by a preposition-like element followed by an obligatory or optional *that*. In (4.60), we have clausal complement constructions introduced by a preposition-like element followed by the complementizer *whether* or a *wh*-word.

Emonds refers to such constructions only in passing (pp. 173, 175, 183) and Jackendoff does not mention them at all. Jespersen (1927: 28-29, 46-49) and Quirk et al. (1985: 998, 1051) note both types. For Jespersen, as for Emonds, they are all PP's with a clausal complement, but for Quirk et al. (p. 1051), only examples like (4.60) are. Examples like (4.59) are regarded as involving complex subordinating conjunctions *in that*, *except that*, and *considering that*, with *that* optional in the latter two (p. 998). Hence, according to Quirk et al., the CAC's in (4.59) are  $\bar{S}$ 's.

There are at least three reasons why these items should not be regarded as forming complex units. It will be useful in this regard to draw comparisons between them and the complex preposition out of discussed in the previous chapter (pp. 61-62). First, if *expect* and

*that*, and *considering* and *that* were single words, *that* should not be optional. In the complex preposition *out of*, neither element is optional.

Secondly, the putative complex subordinating conjunctions can be interrupted by an additional lexical item in ways that *out of* cannot be. The following illustrate:<sup>12</sup>

(4.61) \* The nine black riders appeared out  $\left\{ \begin{array}{l} \textit{precisely} \\ \textit{however} \\ \textit{only} \end{array} \right\}$  of the  
darkness.

(4.62) a. ? They are unwise *in precisely that* they are trying  
to escape.

b. It'll be good if you could come *except, however, that*  
you shouldn't bring your wife.

c. *Considering only that* their evidence compromises the  
Prime Minister, he looks very relaxed.

Thirdly, *that* and the clause following *in, except, and considering* can be conjoined with another *that-S* sequence, but conjoining *of-NP* sequences following *out* is impossible. The following illustrate:

(4.63) \* The nine black riders appeared out of *the barn* and  
*of the castle*. (= (3.17))

(4.64) a. They are unwise *in that they are trying to escape*  
and *that they haven't yet made any provisions for*  
*food and shelter*.

- b. It'll be good if you could come except *that you shouldn't bring your wife and that you'll have to pay to get in.*
- c. Considering *that their evidence compromises the Prime Minister and that the conference is just about to begin*, he looks extremely relaxed.

That the clauses in (4.60) form independent constituents can also be demonstrated by coordination:

- (4.65) a. Mary questioned them on *whether they had been home and who they met on their way.*
- b. They wondered about *why Ann didn't come and whether or not they'd see her again.*
- c. I'm not quite certain of *what he said or what he intended to say.*

The most natural structure for all these constructions is  $P-\bar{S}$ . The superficial difference between them is that those in (4.59) contain declarative clause complements, introduced by the complementizer *that*, and those in (4.60) contain interrogative complements.<sup>13</sup>

With the clausal constructions discussed here, the task of identifying their structure has been easy because their morphology and syntactic properties are quite transparent. It must be noted, however, that there remains a large number of other, more or less preposition-like elements introducing finite and non-finite clauses, which are not so transparent. A comprehensive list can be found in Quirk et al. (1985: 998-1006). It includes *because, in case, in order (that), as if, and as long as*. According to Quirk et al., they are all subordinating conjunctions, simple or complex. According to Emonds and Jackendoff, they are, or would probably be said to involve,



and complementizers is a valid one, two analyses of these CAC's can plausibly be considered: they might be PP's ( $P-\bar{S}$ ) or they might be  $\bar{S}$ 's (COMP-S). I shall now bring three more general issues to bear on the choice between them.

As prepositions, *because*, *although*, etc. would be prepositions that subcategorize only for a clause. This would make them unlike *before*, *after*, etc., which, in addition to an  $\bar{S}$ , can also take an NP complement or no complement, and some can take a PP complement as well (e.g. *since*). As a by-product of analyzing in Chapter 3 *away* in *away from NP* as a specifier, we avoided the conclusion that a preposition can take a PP complement but not an NP complement. On the other hand, a characteristic of some verbs (e.g. *suppose*) is that they take only a clause as a complement. In view of Jackendoff's (1977: 82) emphasis on the importance of similarities between prepositions and verbs in their complement-taking properties, it seems plausible to distinguish a sub-class of prepositions that do not occur in combination with any other constituent but  $\bar{S}$ .

However, this kind of similarity between the two categories should not be over-emphasized: verbs vary in their subcategorization properties much more than prepositions. In particular, as Jackendoff (1977: 79) himself notes, there are verbs, though not prepositions, that can take combinations of two complements:  $NP-\bar{S}$  and  $PP-\bar{S}$ . This is illustrated in (4.67).

(4.67) a. Tom promised [ $\bar{N}$  *his son*][ $\bar{S}$  *that they'd go to the zoo*].

b. It seems [ $\bar{p}$  *to Peter*][ $\bar{S}$  *that he won't see the pandas*].

Furthermore, a verb, but not a preposition, can be followed by two complement PP's, e.g.:

(4.68) They applied [ $\bar{p}$  to the authorities][ $\bar{p}$  for exit visas].

Lastly, some verbs can be followed by the NP-PP combination of complements, e.g.:

(4.69) Stan bought [ $\bar{N}$  a watch][ $\bar{p}$  from a passer-by].

Jackendoff (1973: 350-354; 1977: 79) suggests that there are parallel PP structures in sentences like (4.70).

(4.70) They raced to [ $\bar{N}$  Cambridge] [ $\bar{p}$  in Massachusetts].

This, however, is doubtful since *in Massachusetts* might well be a PP in apposition to *Cambridge*, a possibility that he does not consider.

Thus, a comparison between prepositions and verbs does not provide a strong argument for regarding *because*, *although*, etc. as prepositions.

The next two points encourage the conclusion that these items are complementizers. First, one should bear in mind that the COMP node in these  $P-\bar{S}$  structures would always be empty: *\*because that S* and *\*although whether S*, for example, are impossible, and there is no reason to think that these constructions contain a *wh*-movement clause with a phonologically unrealized *wh*-element in COMP. Thus, rather than prepositions taking an  $\bar{S}$  with an empty COMP, we might regard *because*, etc. as complementizers in the COMP-S structure.

The second point concerns the general picture of the distribution of PP's and  $\bar{S}$ 's. If these CAC's were PP's, there would be no finite  $\bar{S}$ 's functioning as adverbials although there are finite and non-finite  $\bar{S}$ 's functioning as complements, e.g.,

(4.71) a. They expect *that the train will arrive late*.

b. They argued *for the students to have fewer exams*.

and there are non-finite clauses functioning as adverbials, e.g.:

(4.72) She was knocking on the wall *to attract neighbours' attention*.

If *because*-type CAC's were analyzed as  $\bar{S}$ 's, then this gap in the paradigm would not occur.

It looks, then, as if not all CAC's should be regarded as PP's.

#### 4.4. PP's with a clausal complement and the CRP

In Chapter 3 (pp. 86-87), I described in basic terms Stowell's (1981) Case Resistance Principle. I noted there that it excludes not only the P-PP structure but also the P- $\bar{S}$  structure.

Stowell claims that 'prepositions may not take  $\bar{S}$  complements' (p. 391) and illustrates this claim with the following example:

(4.73) \* We are talking about *(that) we should help them*.  
(= S's (29b), p. 393)

He concedes (p. 392), however, that prepositions can be followed by interrogative clauses with a *wh*-phrase in COMP, e.g.:

(4.74) We are talking about *who we should help*.  
(= S's (28b), p. 392)

His account of this contrast is based on the following assumptions:  
(i) Case may not be assigned to a head (rather than a phrase) which bears a Case-assigning feature; (ii) the feature [+ TENSE], which is a Case-assigning feature and, therefore, relevant to the CRP, is associated with the complementizer *that* and the phonologically

unrealized complementizer [e]; (iii) a complementizer is the head of  $\bar{S}$ ; and (iv) a *wh*-question is headed by the fronted *wh*-phrase, which is [+ N], and hence acceptable to the CRP. Assumption (i) is -- in Stowell's words -- a 'refined version of the CRP' (pp. 393-394).

Given these assumptions, Stowell appears to be able to distinguish between those  $\bar{S}$ 's that can occur in a Case marked position and those that cannot. Thus, when Case is assigned to the head of an  $\bar{S}$  headed by a [+ N] element in COMP (e.g. *who* as in (4.74)), the (refined) CRP is not violated, and hence examples like (4.74) are grammatical. When, however, Case is assigned to the head of an  $\bar{S}$  headed by a [+ TENSE] complementizer (i.e. *that* or [e] as in (4.73)), the CRP is violated, and hence examples like (4.73) are ungrammatical. There are two pieces of data that undermine this account. One involves the P- $\bar{S}$  strings as in (4.75), where a *that*-clause or a clause with the empty complementizer [e] appears in a Case marked position.

(4.75) a. They are unwise in *that they are trying to escape*.  
 (= (4.59a))

b. Considering  $\left\{ \begin{array}{l} \textit{that} \\ [e] \end{array} \right\}$  *their evidence compromises the*

Prime Minister, he looks very relaxed. (= (4.59c))

Since these clauses are headed by [+ TENSE] complementizers, they should be ruled out by the CRP just as (4.73) is.<sup>14</sup>

The other datum involves sentences where the clausal complement of a preposition is introduced by *whether*, as in the following example:

(4.76) Mary questioned them on *whether they had been home*.  
 (= (4.60a))

As it is for Emonds and Jackendoff, *whether* is a complementizer within GB (cf. Chomsky 1981: 53), not a *wh*-word moved into COMP by *wh*-movement.

Therefore, like *that*, it should bear the feature [+ TENSE]. When it is assigned Case in contexts like (4.76), where it is governed by a preposition, the CRP is violated.

As we can see, then, even the refined version of the CRP fails to account adequately for the occurrence of clauses as complements of prepositions.<sup>15</sup> Without the CRP, one can account for all the above data simply by referring to specific subcategorization properties of prepositions.

#### 4.5. Conclusion

In this chapter, I have considered a range of clausal constructions for which a  $P-\bar{S}$  structure has been proposed by Emonds 1976 and Jackendoff 1977. I have argued, with reference to certain principles of X-bar Theory and GB assumptions about government and Case assignment, that constructions introduced by *before*, *after*, *since*, and *until* are PP's and not  $\bar{S}$ 's. These arguments throw some more weight behind Emonds' and Jackendoff's argument for the  $P-\bar{S}$  structure of this type of construction, based mainly on their concern for cross-categorial generalizations involving prepositions and verbs. Following in essence Jayaseelan 1983, I have argued that *before*-type CAC's involve *wh*-movement -- a feature not considered by Emonds and Jackendoff. I have highlighted some further fairly obvious examples of the  $P-\bar{S}$  structure, but I have argued that constructions introduced by *because*, etc. are probably not examples of this structure. I have tentatively concluded that they are instances of the COMP-S structure. Finally, I have presented some further evidence against the CRP.

In my discussion, I have made comparisons between prepositions and verbs, and between clause-introducing and 'ordinary' prepositions. I have indicated that there is a similarity between verbs and prepositions

in the variety of clausal complements that they can take -- *that*-clauses, *whether*-clauses, and *wh*-questions -- although only prepositions like *before* seem to allow a clausal complement with a phonologically empty *wh*-operator. I have also pointed out that on the whole, verbs allow a wider range of complements than prepositions, which indicates that there is a limit to the reliability of cross-categorial generalizations involving verbs and prepositions.

By regarding *because*, etc. as complementizers, I have reached a position within which all clause-taking prepositions take an NP as well. With the exception of *away*, *beforehand*, etc., which are always intransitive, intransitive prepositions and prepositions that can take a PP complement can also take an NP. We can say, then, that object of a preposition is a typical NP position without implying that only NP's can appear there. Later on, I shall discuss the occurrence of non-NP's, and PP's in particular, in two other typical NP positions, namely, subject and object.

## NOTES TO CHAPTER 4

1. The temporal *since* in (4.3a) must be distinguished from the causal *since* in sentences like *Since the train was late, we had to walk*, to be discussed in Sub-section 4.3.3.
2. (4.5a) is closer to Jackendoff's structure than to Emonds'. For Jackendoff (1977: 53), both  $\bar{S}$  and  $\bar{S}$  are maximal, three-bar projections of  $\bar{V}$ , the topmost  $\bar{\bar{V}}$  also immediately dominating the COMP node. The following illustrates:

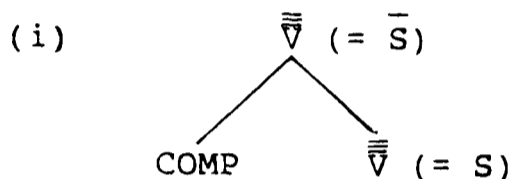

Emonds makes no distinction between  $S$  and  $\bar{S}$ , despite passing references to it (1976: 61 n. 20; 197). For him (pp. 188, 206), COMP is the leftmost sister of the other constituents of  $S$ :

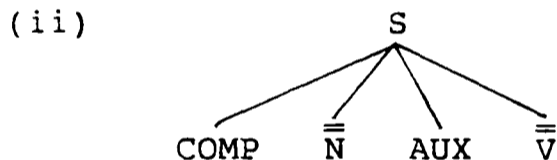

Thus, to be precise, Emonds' 'P- $\bar{S}$ ' structure is a 'P-S' structure. This difference, however, is of no consequence for our discussion. The relevant point is that both authors assume the presence of COMP in clausal complements (cf. Emonds, p. 189; Jackendoff, p. 53).

3. Elsewhere, Jespersen suggests in passing that clause-initial items like *because*, *that*, and *after* are all 'adverbs in a special function' (1914: 15). However, in formal representations of clauses introduced by *because* and *that*, these items are always symbolized as 'connectives' (1937: 72 ff., 78).
4. These examples come from Nigel Vincent's handout entitled 'Syntactic categories old and new: complementizers and conjunctions', distributed at his presentation of the paper to the Philological Society in London, in February, 1980. The paper is not available in a written form. I am grateful to Professor Rebecca Posner for drawing this handout to my attention.
5. Given the alternative  $S/\bar{S}$  structure in (4.19b), the NP is a daughter of  $\bar{\text{INFL}}(S)$ , a maximal projection:

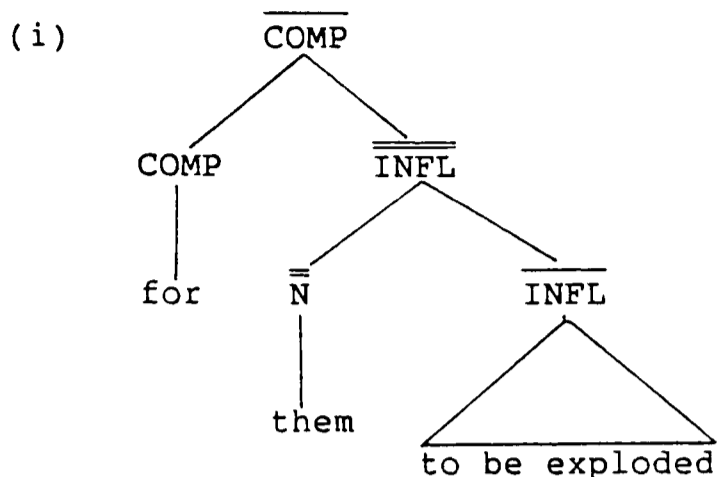

The fact that *for* and *them* are not dominated by the same maximal projections does not prevent *for* from governing and assigning Case to the NP. As suggested by Borer (1984: 252-253), government across INFL boundary is exceptionally possible.

6. Note that with the flexibility in the choice of bounding nodes, extraction from CAC's could be accounted for also if they had the COMP-S structure. Our example in (4.31), \**What did Tom arrive before Ann saw*, would have the following structure:

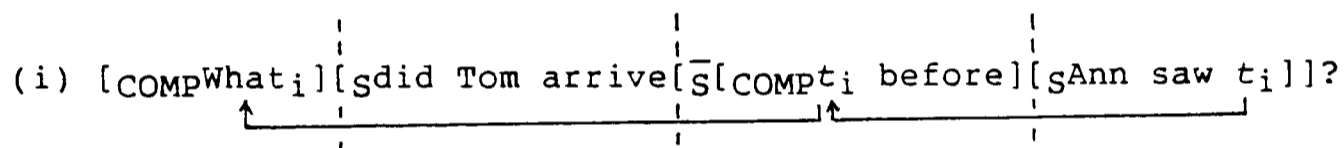

In this case, one would stipulate that an  $\bar{S}$  introduced by *before*, *after*, etc. is a bounding node. As indicated above, two bounding nodes separate the *wh*-element in the higher COMP and the trace in the lower COMP. Since the impossibility of extraction out of *before*-type CAC's can be accounted for with either a P-S structure or a COMP-S structure, considerations of extraction do not seem to provide any evidence as to which is the correct structure.

7. I used the same argument for analyzing *because*-clauses as also instances of the P-NP structure. The relevant paraphrase relation is in (i).

- (i) a. John didn't come *because his car had broken down*.  
 (= J's (3.12a))  
 b. John didn't come *because of the fact that his car had  
 broken down*.  
 (= J's (3.12b))

The criticism of this type of argument developed in the main body of the text and in the next note to this chapter is equally valid in connection with these examples.

8. Neither of these proposals is tenable. First, as noted in Chapter 3 (p. 66), deletion of arbitrary lexical material is undesirable in principle. Secondly, the head of the NP could not be a base-generated empty node because, given GB assumptions, it would have to be either PRO or pro and -- for reasons discussed in Chapter 3 (pp. 67-68) -- neither can be associated with this position.

9. An asterisk before parentheses means that the omission of the marked item renders the sentence unacceptable.
10. I am grateful to Bob Borsley for his assistance with the interpretation of Jayaseelan's discussion.
11. Such sentences are ambiguous when both embedded clauses are in the same tense as the main verb. In Jayaseelan's example in (i),

(i) Bill arrived three days before Mary claims that he arrived.  
(= J's (2))

there is no ambiguity because the present tense of *claim* makes this clause irrelevant to the interpretation of the time of Bill's arrival, which was in the past. Thus, (i) can only be interpreted as expressing a temporal relation between the time of Bill's actual arrival and the time of his arrival announced by Mary.

12. The possibility of separating a preposition and its  $\bar{S}$  complement in these constructions is noteworthy in view of the fact that a preposition and its NP or PP complement cannot be so separated (cf. the examples in (3.33) and (3.34) above).
13. Notice that Jackendoff's obligatory *that*-deletion transformation quoted in (4.8) above (p. 100) would unduly affect the strings *in that S*, *except that S*, and *considering that S*.
14. *Before*-type CAC's might not be a problem for this account if the empty operator in COMP is, like *wh*-words, [+ N].
15. A more general objection to this account is that it seems to imply that a transformation can change a category label. It has been generally accepted since Jackendoff (1972: 13), however, that syntactic transformations cannot change category labels. Within Stowell's analysis, prior to *wh*-movement, COMP contains the complementizer [e], which -- according to the assumption in (ii) in the text -- is [+ TENSE], and -- according to the assumption in (iii) in the text -- [e] is the head of the S. Thus, prior to *wh*-movement, an S is [+ Tense]. When a *wh*-phrase has been moved into COMP, it becomes the head of S and the S is no longer [+ TENSE] but [+ N]. Except for the sake of the CRP, there seems to be no reason why such a change of the category of S should take place.

## CHAPTER 5

## THE P-P-NP STRINGS IN POLISH

5.1. Introduction

In the last two chapters, I discussed the arguments for and against associating certain English strings with the structures P-PP and P- $\bar{S}$ . I hope to have demonstrated that there is a good case for both although their scope is narrower than originally assumed.

In the present and the next chapter, I shall consider the applicability of these structures to Polish data. Although less widespread than in English, both structures occur in Polish.

These chapters have a rather different character from the previous two. The present chapter is quite brief because of absence of earlier discussion of the P-P-NP strings in Polish and because I shall only consider two types of P-P-NP string. One is where the prepositions form a complex preposition and the other is where the first preposition takes a PP complement.<sup>1</sup> I shall not be discussing the other two structures considered in Chapter 3. The following examples might be relevant here:

(5.1) a. *Wokół w ogrodzie rosły jabłonie.*

around in garden grew apple trees

'Apple trees grew about in the garden.'

b. *Obok u sąsiadów jest dziś wesele.*

by at neighbours is today wedding

'There is a wedding on at the next door neighbours' today.'

In these P-P-NP strings, the intransitive prepositions might plausibly be specifiers within the PP's or they might be separate constituents. It is, however, difficult to establish their structure because standard tests yield ambiguous results.

The present chapter is organized as follows. In Section 5.2, I discuss complex prepositions. Some of these are well-established in the language but others are not. In Section 5.3, I investigate the P-P-NP strings which are instances of the P-PP structure. Section 5.4 contains some concluding remarks.

## 5.2. Complex prepositions

We saw in Chapter 3 (pp. 62-64) that in many examples of the P-PP structure in English, the first preposition in the string is the source preposition *from* and the second is a place preposition (e.g. *from under the Russians' feet*). PP's of this form have a Path-Place pattern. The Polish counterparts of such PP's involve what looks like a single preposition and an NP:

(5.2) a. *Kot wyskoczył zza domu.*

cat jumped from-behind house(GEN)

'A cat jumped from behind the house.'

b. *Autobus odjechał spod mostu.*

bus drove-away from-under bridge(GEN)

'A bus drove away from under the bridge.'

- c. Ci delegaci byli *spoza* Gdyni.  
 these delegates were from-outside Gdynia(GEN)  
 'These delegates were from outside Gdynia.'
- d. Ojciec podniósł głowę *znad* gazety.  
 father lifted head from-over newspaper(GEN)  
 'Father lifted his head from over a newspaper.'
- e. *Sprzed* Ratusza ruszyła procesja.  
 from-in-front-of City Hall(GEN) moved procession  
 'A procession moved from in front of the City Hall.'
- f. Ta informacja pochodzi *sprzed* niedzieli.  
 this information comes from-before Sunday(GEN)  
 'This information comes from before Sunday.'

The glosses illustrate that the prepositional elements have a complex meaning. The elements responsible for it can easily be identified. One is *z-*, spelt as *s-* when the following letter represents a voiceless consonant, which corresponds to the source preposition *z* 'from'. The other elements correspond to the prepositions *za* 'behind', *pod* 'under', *poza* 'outside', *nad* 'over', and *przed* 'in front of' or 'before', respectively. All these prepositions can be used to express a place or a goal in space, and *przed* can additionally be used to express a place in time, though not a goal in time. As a whole, each PP in the above examples expresses a Path-Place relation.

There are good reasons to believe that we have complex prepositions here, as the orthography suggests. Thus, as was the case with the complex preposition *out of* (cf. Chapter 3, pp. 61-62 above), they cannot be interrupted by a modifier, e.g.,

(5.3) \* Kot wyskoczył z tuż za domu.

cat jumped from right behind house

and it is impossible to conjoin the second element and the NP with a similar string:

(5.4) \* Ci delegaci byli spoza Gdyni

these delegates were from-outside Gdynia

i poza Warszawy.

and outside Warsaw

Furthermore, the case marking associated with the NP's in these strings is genitive. Genitive is required by the source preposition *z* when it appears on its own, e.g.:

(5.5) Kot wyskoczył z domu.

cat jumped from house(GEN)

The other elements, when they appear on their own in Place PP's, require an instrumental NP complement.<sup>2</sup> The following illustrate:

(5.6) a. Kot siedzi za domem.

cat sits behind house(INST)

b. Autobus stoi pod mostem.

bus stands under bridge(INST)

c. Konferencja odbyła się poza miastem.

conference took-place PRT outside city(INST)

d. Ojciec pochyla się nad gazetą.

father leans PRT over newspaper(INST)

e. Procesja stoi przed Ratuszem.

procession stands in-front-of City Hall(INST)

f. Powiedzieli im to *przed niedzielą*.

they-told them this before Sunday(INST)

If *zza domu* 'from-behind the house', etc. were instances of the P-PP structure, one would expect the NP's to be in the instrumental case. As (5.7) illustrates, this is not even a possibility.

(5.7) \* *Autobus odjechał spod mostem.*

bus drove-away from-under bridge(INST)

It is evident, then, that the items in (5.2) are complex prepositions taking a genitive NP complement.

There appear to be other complex prepositions, not written as a single word. They occur in sentences like the following:

(5.8) a. *Wujek mieszkał w Warszawie do przed wojny.*

uncle lived in Warsaw until before war(GEN)

'Uncle lived in Warsaw until before the war.'

b. *Tomek i Alek przyjaźnią się od przed wakacji.*

Tomek and Alek are-friends PRT since before holidays(GEN)

'Tomek and Alek have been friends since before

the holidays.'

Here, we have temporal PP's consisting of the goal preposition *do* 'until' and the source preposition *od* 'since' followed by the (temporal) place preposition *przed* 'before'.<sup>3</sup> The NP's are in the genitive case, which -- as illustrated in (5.9) -- is normally required by *do* and *od*. We saw in (5.6f) above that *przed* requires an instrumental NP.

(5.9) a. *Wujek mieszkał w Warszawie do wojny.*

uncle lived in Warsaw until war(GEN)

b. Tomek i Alek przyjaźnią się od wakacji.

Tomek and Alek are-friends PRT since holidays(GEN)

The genitive case marking of the NP's in (5.8) suggests that they do not form 'simple' PP's with *przed* in the respective strings. If they did, we would expect them to be in the instrumental case.

There are two structures that one might plausibly consider for these strings. They are presented in (5.10). I use the string *do przed wojny* 'until before the war' for the purpose of illustration.

(5.10) a.

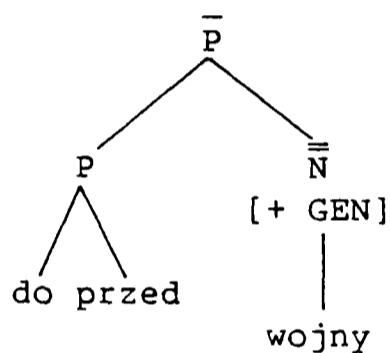

b.

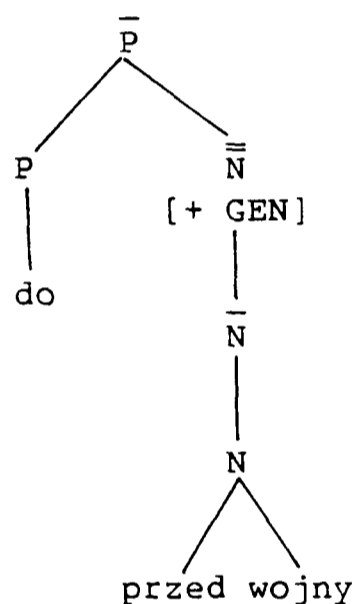

According to the first of these diagrams, the two prepositions form a complex preposition. This would be like the prepositions *zza* 'from-behind', etc. in having complex meaning and requiring a genitive NP complement.

According to the second diagram, *przed* is part of a complex noun, analogous to nouns like *przedwiosnie* 'early spring' or *przedszkole* 'kindergarten', in which one can identify the elements *przed*, and *wiosna* 'spring' and *szkoła* 'school', respectively. Literally, then, *przedwiosnie* means 'before-spring' and *przedszkole*, 'before-school'.

A number of considerations suggest that the 'complex preposition' analysis is preferable to the 'complex noun' analysis.

First, a modifier can be inserted between *przed* and the noun:

- (5.11) a. Wujek mieszkał w Warszawie *do* *przed* *pierwszej wojny*.  
 uncle lived in Warsaw until before first war
- b. Tomek i Alek przyjaźnią się *od* *przed*  
 Tomek and Alek are-friends PRT since before  
*tamtych wakacji*.  
 those holidays

This would not be possible if *przed* and *wojny*, and *przed* and *wakacji* were single lexical items.

Secondly, as single nouns, these combinations would be expected to appear in other environments, with different case markings, as in (5.12).

- (5.12) a. \* *Przedwojna* była tematem wielu filmów.  
 before-war(NOM) was subject many films
- b. \* Tomek miło wspomina *przedwakacje*.  
 Tomek pleasantly remembers before-holidays(ACC)

Here, the putative nouns are, respectively, a subject in the nominative case and an object in the accusative case. Neither example is acceptable.

Thirdly, and lastly, if *przed wojny* and *przed wakacji* were complex nouns, one would expect to be able to conjoin them with other similar expressions. As (5.13) illustrates, this too is impossible.

- (5.13) a. \* Wujek mieszkał w Warszawie do *przed pierwszej wojny*  
 uncle lived in Warsaw until before first war  
 lub *przed drugiej.*  
 or before second
- b. \* Tomek i Alek przyjaźnią się od *przed wakacji*  
 Tomek and Alek are-friends PRT since before holidays  
 lub *przedwiosnia.*  
 or before-spring

These three observations are compatible with the 'complex preposition' structure in (5.10a) above. It is additionally supported by the impossibility of the appearance of a modifier between the two prepositional elements:

- (5.14) a. \* Wujek mieszkał w Warszawie *do tuż przed wojny.*  
 uncle lived in Warsaw until right before war
- b. \* Tomek i Alek przyjaźnią się *od tuż*  
 Tomek and Alek are-friends PRT since right  
*przed wakacji.*  
 before holidays

However, the complex prepositions *do przed* and *od przed* appear to be less stable than *zza*, etc. As we shall see in the next section, *do*, *od*, and *przed* together with a handful of other prepositions can occur in P-P-NP strings with the P-PP structure.

### 5.3. Prepositions with PP complements

We can now consider the P-P-NP strings in the following sentences:

- (5.15) a. Kłócili się do po filmie.  
 they-argued PRT until after film(LOC)  
 'They argued until after the film.'
- b. Wujek mieszka w Warszawie od po powstaniu.  
 uncle lives in Warsaw since after uprising(LOC)  
 'Uncle has been living in Warsaw since after the uprising.'
- c. Umówili się na przed rozpoczęciem roku  
 they-appointed PRT for before beginning(INST) year  
 szkolnego.  
 school  
 'They made an appointment for before the beginning of the  
 school year.'
- d. Postanowili zostawić tę czekoladę na po egzaminie.  
 they-decided leave this chocolate for after exam(LOC)  
 'They decided to leave this chocolate for after the exam.'

Here, the first three PP's are temporal expressions and the last one is arguably a purpose expression. All these PP's follow a Path-Place pattern of the strings considered previously. The NP's in these examples are in the locative or instrumental case. These are the cases that are required by the immediately preceding place prepositions *po* 'after' and *przed* 'before' when they appear in 'ordinary' Place PP's:<sup>4</sup>

- (5.16) a. Kłócili się po filmie.  
 they-argued PRT after film(LOC)
- b. Umówili się przed rozpoczęciem roku szkolnego.  
 they-appointed PRT before beginning(INST) year school

Of the other prepositions, the goal preposition *do* 'until' and the

source preposition *od* 'since' require their complements to be in the genitive case (cf. (5.9) above), and the goal preposition *na* 'for' requires an accusative NP:<sup>5</sup>

- (5.17) *Postanowili zostawić tę czekoladę na egzamin.*  
 they-decided leave this chocolate for exam(ACC)

At this point, we can eliminate one potential analysis of these strings, one in which they involve complex nouns composed of the second preposition and the noun in the complement of the first preposition (cf. the diagram in (5.10b) above). If this analysis were correct, the putative complex nouns in (5.15) would bear, appropriately, the genitive or the accusative case marking.

A second analysis that might be considered is one in which we have complex prepositions *do po* 'until-after', *na po* 'for-after', and *na przed* 'for-before', requiring their NP complements to bear the locative case (cf. the diagram in (5.10a) above). This possibility is ruled out, however, by the fact that the prepositions can be separated by a modifier, e.g.,

- (5.18) a. *Kłócili się do długo po filmie.*  
 they-argued PRT until long after film
- b. *Wujek mieszka w Warszawie od tuż po powstaniu.*  
 uncle lives in Warsaw since right after uprising
- c. *Umówili się na krótko przed rozpoczęciem roku.*  
 they-appointed PRT for shortly before beginning year
- d. *Postanowili zostawić tę czekoladę  
 they-decided leave this chocolate  
 na tuż po egzaminie.  
 for right after exam*

and by the fact that the second preposition and the NP can be conjoined with another similar string:<sup>6</sup>

- (5.19) a. Kłócili się do po filmie albo po Dzienniku.  
 they-argued PRT until after film or after the News
- b. Wujek mieszka w Warszawie od po powstaniu lub  
 uncle lives in Warsaw since after uprising or  
 po wyzwoleniu.  
 after liberation
- c. Umówili się na przed rozpoczęciem roku i  
 they-appointed PRT for before beginning year and  
 przed pierwszym zebraniem związku.  
 before first meeting of-union
- d. Postanowili zostawić tę czekoladę na po egzaminie  
 they-decided leave this chocolate for after exam  
 lub nawet po absolutorium.  
 or even after graduation

These facts argue against the complex preposition analysis and in favour of the P-PP analysis of these strings. (5.20) illustrates the structure of the string *do po filmie* 'until after the film'.

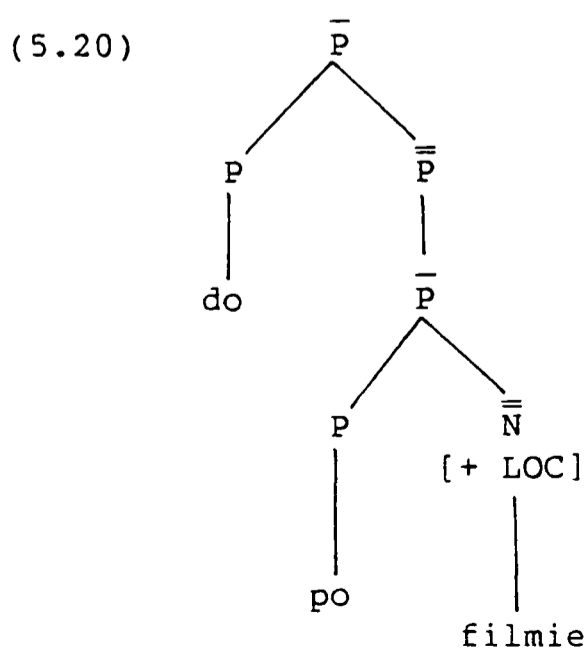

Given this structure, the modifier appearing between the two prepositions in (5.18) is a specifier in the complement PP, and the coordination in (5.19) involves two complement PP's. The case marking of the NP's in these strings is determined by the second preposition, and the first preposition is not involved in case marking, as its complement is a PP. We can conclude, then, that *do*, *od*, and *na* take not only an NP but also a PP complement.

It will be recalled that in earlier discussion in this chapter (pp. 143-146), *do* and *od* appeared in the P-P-NP strings *do przed wojny* 'until before the war(GEN)' and *od przed wakacji* 'since before the holidays(GEN)', in which they were part of complex prepositions. I remarked then (p. 146) that they were not as 'stable' as *zza* 'from-behind', etc.

By this, I mean that these strings can also appear in the P-PP structure. Thus, along with (5.8), repeated here in (5.21), the sentences in (5.22) are also possible.

(5.21) a. *Wujek mieszkał w Warszawie do przed wojny.*

uncle lived in Warsaw until before war(GEN)

'Uncle lived in Warsaw until before the war.'

(= (5.8a))

b. *Tomek i Alek przyjaźnią się od przed wakacji.*

Tomek and Alek are-friends PRT since before holidays(GEN)

'Tomek and Alek have been friends since before

the holidays.'

(= (5.8b))

(5.22) a. *Wujek mieszkał w Warszawie do krótko przed wojną.*

uncle lived in Warsaw until shortly before war(INST)

- b. Tomek i Alek przyjaźnią się od tuż  
 Tomek and Alek are-friends PRT since right  
*przed wakacjami.*  
 before holidays(INST)

We can see that in the latter pair of examples, the prepositions are separated by a modifier and that the case marking of the following NP's is instrumental, as required by the second preposition in the string, *przed*. When the case marking of the following NP's is genitive, as in (5.21), a modifier cannot appear between the prepositions (cf. (5.14) above).

The strings with instrumental NP's are less acceptable without the modifiers separating the prepositions, but I do not find them wholly unacceptable. It seems that where the two prepositions are adjacent, they are more likely to be considered as a unit, in which situation, the NP assumes the genitive case. The acceptability of these P-P-NP strings with instrumental NP's increases with the *przed* stressed.

In contrast to these strings, the strings in (5.15) above are quite stable, i.e., the case marking of the NP can never be the same as that required elsewhere by the first preposition. (5.23) illustrates that the case form of the NP's in these P-P-NP strings does not vary.

- (5.23) a. \* Kłócili się do po filmu.  
 they-argued PRT until after film(GEN)
- b. \* Wujek mieszka w Warszawie od po wojny.  
 uncle lives in Warsaw since after war(GEN)
- c. \* Umówili się na przed rozpoczęcie roku.  
 they-appointed PRT for before beginning(ACC) year

- d. \* Postanowili zostawić tę czekoladę na po egzamin.  
 they-decided leave this chocolate for after exam(ACC)

So far, I have been discussing examples with temporal prepositions as providing evidence for the P-PP structure. These are in fact its most transparent instances. To see this, we can consider the following examples of spatial PP's:

- (5.24) a. ?? Adam prowadził od (tuż) za Poznaniem  
 Adam drove from right beyond Poznań(LOC)  
 do samego Torunia.  
 to itself Toruń  
 'Adam drove from (right) beyond Poznań to Toruń itself.'
- b. ?\* Adam prowadził od (tuż) pod Poznaniem  
 Adam drove from right under Poznań(LOC)  
 do samego Torunia.  
 to itself Toruń
- c. \* Adam prowadził z (tuż) pod Poznaniem  
 Adam drove from right under Poznań(LOC)  
 do samego Torunia.  
 to itself Toruń
- d. Adam prowadził (tuż) spod Poznania.  
 Adam drove right from-under Poznań(GEN)

In the first three examples here, we have the source prepositions *od* 'from' and *z* 'from', which require a genitive NP complement. The NP's in these strings are in the locative case, as required by the place prepositions *za* 'beyond' and *pod* 'under' (or 'outside' in this context). The prepositions are separated from each other by a modifier. Thus, the strings in the first three examples above have the characteristics of

the P-PP structure.

As I have indicated, none of these three examples is (fully) acceptable although there seem to be differences between them in this respect. We can explain this by comparing the meaning and the form of the PP's there with the PP in the last example, (5.24d), which is fully acceptable.

All four PP's express (or are intended to express) motion from a certain place, specifying its direction and the precise position of the source of the motion. In the first three PP's, the complex meaning is expressed by combinations of two individual prepositions in a 'complex' (P-PP) structure but in the last PP, the complex meaning is expressed by a single preposition, *spod* 'from-under', in a 'simpler' (P-NP) structure.

The elements of this single preposition are *z-* 'from' and *-pod* 'under' (cf. p. 141 above). The P-P-NP string in (5.24c) contains just these elements in the P-PP structure. Given the availability of the single item *spod* in the lexicon, a sentence with the string *z pod* is unacceptable. In (5.24b), the string *od pod* contains only one preposition formally identical to a part of *spod*. This example appears to be slightly more acceptable than the one with *z pod*. Finally, in the string *od za* in (5.24a), both elements are formally different from the elements of *spod* and the example seems the most acceptable.

Similar comparisons could be carried out between the unacceptability of the P-PP structures in *\*Wyszedł z za domem* 'He came from behind the house(LOC)' vs *Wyszedł z za domu* 'He came from-behind the house(GEN)', etc. In each case, the P-P string has a single semantic and formal equivalent in the lexicon, which renders the P-PP structures redundant.

Among the complex prepositions, there are fewer items that express various complex temporal relations than spatial relations (cf. *sprzed (niedzieli)* 'from-before (Sunday)' and the less well-established *do przed (wojny)* 'until before (the war(GEN))' and *od przed (wakacji)* 'since before (the holidays(GEN))'). The 'gaps' in the lexicon are compensated for by the P-PP structures.

#### 5.4. Conclusion

In this chapter, I have considered the structure of certain P-P-NP strings in Polish. After discussing straightforward examples of complex prepositions, I have argued that some cases of separate prepositions are actually single complex prepositions. I then showed that some P-P-NP strings have the P-PP structure although this is relatively rare because of the existence of complex prepositions.

The fact that prepositions in Polish can take a PP complement lends further support to Jackendoff's (1977) claim that prepositions and morphological case markers should be regarded as distinct entities (cf. Chapter 1, p. 4 above). If every preposition were always to be accompanied by a case ending, then one might expect the NP in a P-PP structure to bear two case endings. The Polish examples show very clearly that NP's bear only one case marker even in structures where two individual prepositions are present.

The occurrence of the P-PP structure in Polish provides a further argument in favour of regarding Polish prepositions as heads of phrases (cf. Chapter 1, pp. 26-29 above). Not only do prepositions determine the internal structure of the phrase by selecting an NP complement in a particular case but also by selecting a constituent of a different syntactic category.

## NOTES TO CHAPTER 5

1. I presented some of the ideas in the present chapter in a paper entitled 'Taking Polish prepositions seriously', read at the Slavonic Linguistics Seminar VII at Sheffield, 10-11 September, 1985. I am grateful to doc. dr hab. Tadeusz Zabrocki for his comments on an earlier version of that presentation.

2. The accompaniment preposition *z* 'with' requires an instrumental NP complement. The goal prepositions *za* 'behind', *pod* 'under', *poza* 'outside', *nad* 'over', and *przed* 'in-front-of' require an accusative NP complement.

Following Saloni and Świdziński (1985: 114-115), I tentatively assume that, e.g. the goal and accompaniment *z* is formally represented in the lexicon as two separate lexical items with different subcategorization features, which include the specification of the case marking of the NP complement. In Chapter 10, Section 10.4, I discuss an idea according to which single lexical entries of prepositions with underspecified complements might be more appropriate.

3. *Do* and *od* can also appear in spatial PP's.

4. *Po* 'for' takes an accusative NP in purpose expressions.

5. The NP complement of *na* 'on' is locative in Place PP's.

6. The sentence in (5.19a) has two possible interpretations, represented schematically in (i).

- (i) a. Kłócili się [do [po filmie] albo [po Dzienniku]]  
 b. Kłócili się [[do po filmie] albo [po Dzienniku]]

The intended interpretation is that in (ia), and this is the more likely one. The other sentences in (5.19) appear to be unambiguous.

## CHAPTER 6

## COMPLEX ADVERBIAL CONSTRUCTIONS IN POLISH

6.1. Introduction

We can now turn to some Polish CAC's. As was mentioned in the introduction to the previous chapter (p. 131), Polish also has the P- $\bar{S}$  structure although, like the P-PP structure, this is less widespread than in English. Another -- and perhaps more interesting -- difference between the two languages in this area is that some Polish CAC's are PP's containing an intransitive preposition as the head and a modifying clause. Some CAC's in Polish have the COMP-S structure, which, unlike in the case of their English counterparts, can be easily established on the basis of empirical considerations.

The chapter is organized as follows. In Section 6.2, I argue that CAC's of the form *mimo że S* 'despite that S' and *podczas gdy S* 'during when S' are instances of the P- $\bar{S}$  structure and not of the COMP-S structure, as is implicitly assumed in Polish work on Polish grammar. In Section 6.3, I present evidence for analyzing certain other CAC's in terms of the COMP-S structure. In Section 6.4, I consider a class of CAC's among which there are translational counterparts of *before-type* CAC's. I argue with Polish linguists that they involve a relative clause construction but I analyze them as PP's rather than ADP's or NP's. Another class of complex adverbials (and complements) -- some of them counterparts of the most transparent instances of the P- $\bar{S}$  structure in

English are also PP's, with another type of modifying clause. Section 6.5 contains some concluding remarks.

## 6.2. PP's with an $\bar{S}$ complement

### 6.2.1. The case of *mimo*

One of the most obvious candidates for the P- $\bar{S}$  structure in Polish is the complex construction introduced by *mimo* 'despite':<sup>1</sup>

(6.1) a. *Idę na spacer, mimo że pada deszcz.*

I-go on walk despite that falls rain

'I'm going for a walk despite the fact that it's raining.'

b. *Wojna wybuchła, mimo że podpisano porozumienie.*

war broke-out despite that one-signed agreement

'A war broke out despite the fact that an agreement had been signed.'

As is illustrated in (6.2), *mimo* can be followed by an NP in the genitive case in what is most obviously a PP.

(6.2) a. *Idę na spacer mimo deszczu.*

I-go on walk despite rain(GEN)

b. *Mimo niepowodzeń, Tomek był optymistą.*

despite failures(GEN) Tomek was optimist

Since *mimo* is a preposition in (6.2), it is natural to suppose that it is a preposition in (6.1) also, taking a clause ( $\bar{S}$ ) with the complementizer *że* 'that' as a complement.

In Polish works on grammar, however, *mimo* and *że* are regarded as a single lexical item. Klemensiewicz (1957: 72) and Grochowski (1984a: 295) list *mimo że* among 'conjunctions' (*spójniki*), and Walczak (1975:

59) refers to them as a 'group of conjunctions' (*zespół spójników*), which form an 'indivisible sign' (*niepodzielny znak*; Walczak (p.57)). It is not clear, however, why Walczak assumes that *mimo* itself is a conjunction, given that examples like (6.3), where *mimo* might be construed as a conjunction, are unacceptable.

(6.3) \* *Idę na spacer, mimo pada deszcz.*

I-go on walk despite falls rain

The only reference to *mimo* as a preposition in the context of a discussion of this construction can be found in Grochowski's work. Grochowski (1977: 19-20) advances an argument for analyzing *mimo* and *że* (and certain other items to be discussed in this chapter) as a single conjunction against an analysis -- essentially Walczak's -- in which they are a string of two conjunctions. He rightly points out that there is no reason to regard *mimo* as a conjunction because elsewhere it can only be a preposition (cf. (6.2) and (6.3) above). From this, however, he immediately concludes that *mimo* forms a single conjunction with *że*. Grochowski does not consider the possibility that *mimo* in combination with a *że*-clause might be a preposition. This is not surprising, given his assumption (p. 18) that prepositions can only combine with NP's.

Within an approach in which the two items form a complex conjunction, CAC's like those in (6.1) above have -- in our terms -- the COMP-S structure. Below, I shall argue that the P- $\bar{S}$  structure is better-motivated. Both structures are depicted in (6.4) for the string *mimo że pada deszcz* 'despite the fact that it's raining' in (6.1a).

(6.4) a.

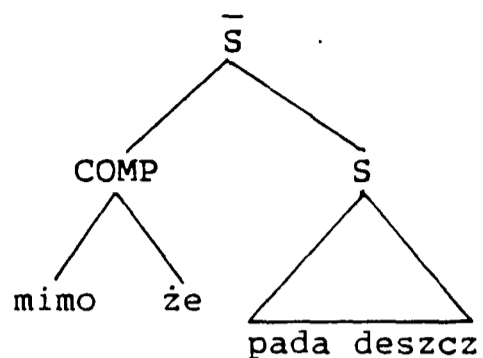

b.

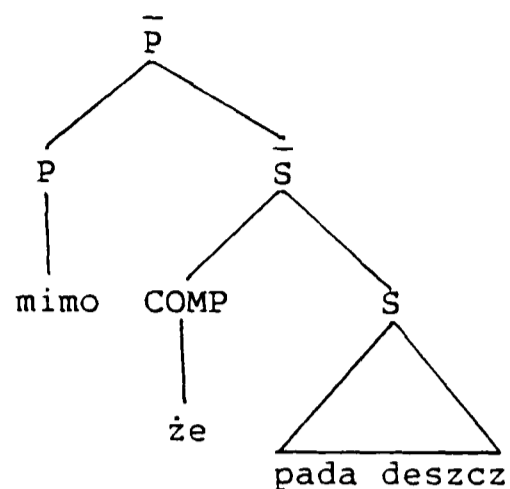

Advocates of the 'complex conjunction' analysis appear to see some support for their position in the fact that both elements are usually adjacent and the fact that they are both obligatory.

If they were always adjacent, there might be a case for considering them as a unit. However, as (6.5) illustrates, a lexical item can appear between them.

(6.5) *Mimo jednak, że od tej pory ich egzystencja oparła*  
 despite however that from this time their existence rested  
*się na wątkiej podstawie, jakość życia niewątpliwie*  
 PRT on meagre foundations quality life undoubtedly  
*podniosła się znacznie.*

raised PRT significantly

'However, despite the fact that from this time their existence  
 rested on meagre foundations, the quality of their lives  
 undoubtedly increased significantly.'

(KTT, Polityka, 26.7.1986.)

Moreover, it is possible to conjoin a *że*-clause following *mimo* with another *że*-clause:

(6.6) Pożar ugaszono, mimo że przyjechało tylko dwóch  
 fire one-extinguished despite that arrived only two  
 strażaków i że zabrakło wody.  
 firemen and that lacked water  
 'The fire was extinguished despite the fact that only two  
 firemen arrived and that water ran out.'

Both these pieces of data show that *mimo* and *że* do not form an 'indivisible unit'. For comparison, we can recall the complex prepositions *zza* 'from-behind', etc. from the previous chapter (pp. 140-142), which cannot be interrupted by an additional lexical item and whose second element cannot appear in a conjunct (cf. examples (5.3) and (5.4) above). Within the P- $\bar{S}$  analysis of the *mimo*-construction, *jednak* 'however' in (6.5) appears between a head and its complement, and coordination in (6.6) involves two  $\bar{S}$ 's.<sup>2</sup>

The fact that both *mimo* and *że* are obligatory is also compatible with this analysis. *Mimo* is obligatory because it is the head of a phrase, like *mimo* in straightforward PP's. (6.7) illustrates that an omission of *mimo* from an 'ordinary' PP and an omission of *mimo* from a clausal construction are equally unacceptable.

- (6.7) a. Idę na spacer \*(*mimo*) *deszczu*.  
 b. Idę na spacer \*(*mimo*) *że pada deszcz*.

*Że*, on the other hand, is obligatory because in Polish, finite subordinate clauses must contain an overt complementizer or a *wh*-element in COMP. The following examples with their English translations illustrate that Polish differs from English in this respect:

(6.8) a. Piotr powiedział, że Alek lubi truskawki.

'Piotr said that Alek likes strawberries.'

b. \* Piotr powiedział Alek lubi truskawki.

'Piotr said Alek likes strawberries.'

(6.9) a. Książki, które zamówiłeś zostały przyniesione.

'The books which you ordered have been delivered.'

b. \* Książki, zamówiłeś zostały przyniesione.

'The books you ordered have been delivered.'

Another argument against the COMP-S and in favour of the P-S̄ analysis of the *mimo*-construction is provided by considerations of simplicity of the lexicon. This argument involves the additional examples of this construction presented in (6.10).

(6.10) Wojna wybuchła,  $\left\{ \begin{array}{l} \textit{mimo iż} \\ \textit{pomimo że} \\ \textit{pomimo iż} \end{array} \right\} \textit{podpisano porozumienie.}$

war broke-out despite that one-signed agreement

Here, we have *pomimo* and *iż*, which are interchangeable with *mimo* and *że*, respectively. Elsewhere, *pomimo* is a preposition and *iż*, a complementizer:

(6.11) a. Idę na spacer *pomimo* deszczu.

I-go on walk despite rain(GEN) (cf. (6.2a))

b. Piotr powiedział, *iż* Alek lubi truskawki.

Piotr said that Alek likes strawberries (cf. (6.8a))

Within the 'complex conjunction' analysis, one must recognize four distinct complex conjunctions in addition to the simple items of which they consist. (All four complex items are, in fact, included in Grochowski's (1984a: 295-296) list of conjunctions.) Within the P- $\bar{S}$  analysis, the lexicon is simpler: *mimo* and *pomimo* are prepositions which require an NP or an  $\bar{S}$  with *że* or *iż*. In this respect, they are like the verb *żałować* 'regret', for example, which -- as (6.12) purports to illustrate -- also takes only these two kinds of complement.

(6.12) a. Tomek *żałował*  $\left\{ \begin{array}{l} \textit{tej decyzji.} \\ * \textit{ o tej decyzji} \end{array} \right.$   
 Tomek regretted  $\left\{ \begin{array}{l} \textit{this decision(GEN)} \\ \textit{about this decision} \end{array} \right.$

b. Tomek *żałował*,  $\left\{ \begin{array}{l} \textit{że} \\ \textit{iż} \\ * \textit{ czy} \\ * \textit{ żeby} \end{array} \right\}$  *zaprosił Wojtkę.*  
 Tomek regretted  $\left\{ \begin{array}{l} \textit{that} \\ \textit{whether} \\ \textit{so that} \end{array} \right\}$  he-invited Wojtek

I conclude, then, that the *mimo*-construction illustrated in (6.1) is an instance of the P- $\bar{S}$  structure.

### 6.2.2. The case of *podczas*

We turn now to CAC's introduced by *podczas* 'during' illustrated in (6.13).<sup>3</sup>

- (6.13) a. *Podczas, gdy mama była w kinie, tata*  
 during when mother was in cinema father  
*grał w szachy.*  
 played in chess  
 'When mother was in the cinema, father was playing chess.'
- b. *Adam czytał książkę podczas, gdy rozdawano nagrody.*  
 Adam read book during when one-handed prizes  
 'Adam was reading a book when the prizes were being  
 handed out.'

Like *mimo* and *że*, *podczas* and *gdy* are listed as a single conjunction in Polish work (cf. Klemensiewicz 1937: 205; Szober 1923: 374; Grochowski 1984a: 296). As in the previous case (cf. p. 158 above), Grochowski (1977: 19) argues that they form a single conjunction rather than a string of two conjunctions because elsewhere, *podczas* is a preposition, not a conjunction. (6.14) contains Grochowski's example.

- (6.14) *Podczas jego nieobecności wiele się zmieniło.*  
 during his absence(GEN) much PRT changed  
 'Much has changed during his absence.'

Here again, Grochowski does not consider the possibility that *podczas* might be a preposition followed by a clausal complement, a position that I shall argue for.

While *podczas* can appear elsewhere as a preposition in sentences like (6.14), *gdy* 'when' can appear elsewhere also, for example, introducing a relative clause:

(6.15) W czasie, *gdy* mama była w kinie, tata  
 in time when mother was in cinema father  
 grał w szachy.  
 played in chess  
 'At the time when mother was in the cinema, father was  
 playing chess

Apart from *gdy*, *podczas* in a clausal construction can be followed by *kiedy* 'when' and *jak* 'how' in the sense of 'when'. Thus, (6.16) is an alternative to (6.13a) above.

(6.16) Podczas,  $\left\{ \begin{array}{l} \textit{kiedy} \\ \textit{jak} \end{array} \right\}$  mama była w kinie, tata  
 during when mother was in cinema father  
 grał w szachy.  
 played in chess (cf. (6.13a))

Both these items can appear in relative clauses and *kiedy* can introduce a *wh*-question. The sentence in (6.17), containing a relative clause construction, is an alternative to (6.15) above. In (6.18), we have a question introduced by *kiedy*.

(6.17) W czasie,  $\left\{ \begin{array}{l} \textit{kiedy} \\ \textit{jak} \end{array} \right\}$  mama była w kinie, tata  
 in time when mother was in cinema father  
 grał w szachy.  
 played in chess (cf. (6.15))

(6.18) *Kiedy* mama była w kinie?

when mother was in cinema

'When was mother in the cinema?'

*Jak* can also introduce a *wh*-question, but a *jak*-question is about manner, not time. Thus, the question in (6.19), corresponding to (6.18) above, can only -- with some difficulty -- be interpreted as 'How did it come about that mother was in the cinema?'

(6.19) ? *Jak* mama była w kinie?

If *podczas* and *gdy* were a single lexical item, *podczas* and *kiedy*, and *podczas* and *jak* would have to be also. Thus, in addition to the individual items under consideration, the lexicon would include three additional complex conjunctions. (In addition to *podczas gdy*, *podczas kiedy* is, in fact, included in Grochowski's (1984a: 296) list of conjunctions.) There is no need for these additional complex items given the P- $\bar{S}$  analysis of the *podczas*-construction.

Although *podczas* and the following clause usually appear adjacent, it is possible for a lexical item to appear between them in sentences like the following, similar to the example with *mimo* in (6.5) above:

(6.20) *Podczas jednak,*  $\left\{ \begin{array}{l} \text{gdy} \\ \text{kiedy} \\ \text{jak} \end{array} \right\}$  *robił porządki, znalazł*

during however when he-did tidying he-found  
brakujące dokumenty.

missing documents

'However, when he was tidying up, he found the missing  
documents.'

This should not be possible within the 'complex conjunction' analysis. Within the  $P-\bar{S}$  analysis, on the other hand, such an example is not unexpected.

Unfortunately, we cannot rely on coordination to provide us with another argument in this discussion. Although sentences like (6.21) are acceptable,

(6.21) *Podczas,*  $\left\{ \begin{array}{l} \text{gdy} \\ \text{kiedy} \\ \text{jak} \end{array} \right\}$  *mama była w kinie i*  $\left\{ \begin{array}{l} \text{gdy} \\ \text{kiedy} \\ \text{jak} \end{array} \right\}$  *dzieci*

during when mother was in cinema and when children  
oglądały telewizję, tata grał w szachy.

watched television father played in chess

they need not involve conjoined  $\bar{S}$  complements of *podczas*. This is because clauses introduced by *gdy*, *kiedy*, and *jak* can appear as adverbials by themselves. (6.22) illustrates.

(6.22)  $\left. \begin{array}{l} \text{Gdy} \\ \text{Kiedy} \\ \text{Jak} \end{array} \right\} \text{mama była w kinie, tata grał w szachy.}$

'When mother was in the cinema, father was playing chess.'

Given this fact, the first of the conjuncts in (6.21) may be a PP and the second an  $\bar{S}$ , or the conjuncts may be two  $\bar{S}$ 's in the complement of *podczas*. As far as I can see, there are no examples in which *podczas* is unambiguously followed by conjoined  $\bar{S}$  complements. This, however, does not count as an argument against the P- $\bar{S}$  analysis of the *podczas*-construction.

Assuming this analysis, we should note that unlike *mimo*, *podczas* appears to take a clause which involves *wh*-movement. While in the *mimo*-construction, we have an ordinary complementizer *że* 'that', *podczas* is followed by items which can appear elsewhere in relative clauses (cf. 6.15) and (6.17) above), and *kiedy* can additionally appear in *wh*-questions (cf. (6.18) above). Since relative clauses and *wh*-questions involve *wh*-movement, it seems natural to suggest that *gdy*, *kiedy*, and *jak* in the *podczas*-construction also mark a *wh*-movement clause.

The fact that not only *kiedy* but also *gdy* and *jak* can introduce a complement clause here, makes *podczas* somewhat unlike verbs: as illustrated in (6.23), the latter two cannot introduce a clausal complement of verbs.<sup>4</sup>

(6.23) Dyrektor wie,  $\left\{ \begin{array}{l} * \text{ gdy} \\ * \text{ jak} \\ \text{ kiedy} \end{array} \right\} \text{ przyjedzie delegacja.}$

director knows when will-arrive delegation

It will be recalled from Chapter 4 (p. 125) that a similar conclusion emerged upon the examination of the English *before*-type CAC's. These involve a *wh*-movement clausal complement with the operator *0*, which -- like clausal complements with *gdy* and *jak* -- is also restricted to occurrence within a PP. A difference between the English and the Polish examples of this construction is that the latter contain an overt manifestation of *wh*-movement in the form of *gdy*, *kiedy*, or *jak*.

### 6.3. Bare $\bar{S}$ 's

We can now consider some CAC's for which there is good evidence that the COMP-S and not the P- $\bar{S}$  structure is appropriate. They are exemplified in (6.24)

(6.24) a. Nie mogliśmy przyjechać, *bo* *były* *zaspy*.

not we-could come because were snow-drifts

'We couldn't come because there were snow-drifts.'

b. Tomek oglądał film, *choć* *miał* *sporo* *roboty*.

Tomek watched film although he-had much work

'Tomek was watching the film although he had much work to do.'

c. *Ponieważ* *nie* *byli* *spragnieni*, poprosili

since not they-were thirsty they-asked

tylko o chleb.

only for bread

'Since they were not thirsty, they asked only for bread.'

d. *Odwiedzi* *mnie*, *jeśli* *będzie* *miał* *czas*.

he'll-visit me if he'll have time

'He'll visit me if he has the time.'

These CAC's are introduced by items which are not prepositions elsewhere, and which are widely regarded as subordinating conjunctions. Since they can only introduce adverbial clauses and not complement clauses, we can regard them as specialized complementizers.

As we recall (Chapter 4, pp. 99-100), according to Emonds 1976 and Jackendoff 1977, the category 'preposition' includes all subordinating conjunctions except for a handful of those that are 'complementizers'. If we were to apply this proposal to Polish, *bo* 'because', *choć* 'although', *ponieważ* 'since', and *jeśli* 'if' in (6.24) would be classified as prepositions.

In Chapter 4 (pp. 130-132), I examined Emonds' and Jackendoff's proposal in connection with the English counterparts of these items. I pointed out that in the absence of any obvious empirical evidence, the case for analyzing *because*, etc. as prepositions or as complementizers rests on considerations of symmetry and simplicity. I concluded that CAC's introduced by these items are probably  $\bar{S}$ 's. As I argue below, there can be little doubt that the Polish CAC's in (6.24) are  $\bar{S}$ 's.

For ease of reference, in (6.25), I present the two competing structures. I use the string *bo były zaspły* 'because there were snow-drifts' in (6.24a) above for the purpose of illustration.

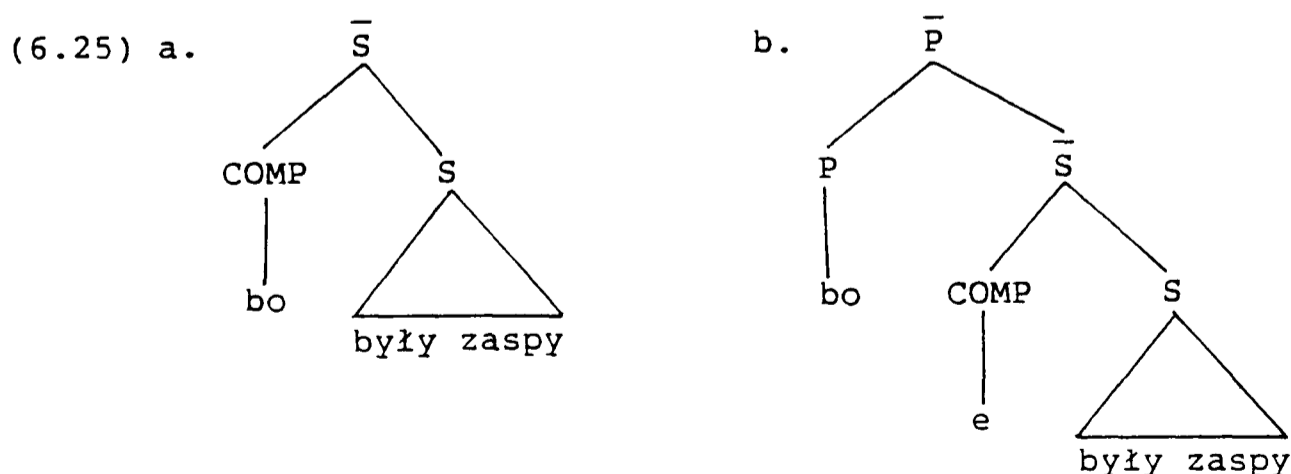

According to the former, the items in question are complementizers, and according to the latter, they are prepositions. There are at least two

arguments in favour of the former structure.

First, notice that in (6.25b), the preposition is followed by a finite clause complement with no overt complementizer or *wh*-element. As was noted earlier (pp. 160-161), however, Polish finite subordinate clauses must have a lexical item in COMP. Given (6.25a), this requirement is fulfilled.

The other argument involves reference to the so-called 'mobile suffixes' (*końcówki ruchome*; cf. Szober 1923: 270; Laskowski 1984c: 183). In Polish, certain person and number suffixes, usually associated with past tense verbs, can appear attached to some other, preceding lexical item.<sup>5</sup> An example of this phenomenon is given in (6.26).

- (6.26) a. Tylko wy                      tam      byliście.  
                     ónly you(2nd/PL) there were(2nd/PL)  
                     b. Tylko wyście tam byli.  
                     c. Tylkoście wy tam byli.

As we can see, in (6.26a), the second person plural suffix *-ście* is in its usual position, attached to the verb. In (6.26b) and (6.26c), it is attached to a preceding lexical item.

An important fact about mobile suffixes, noted in Borsley (1984: 10-11) is that they cannot be attached to a lexical item outside the minimal clause ( $\bar{S}$ ) that contains the verb with which they are associated in the first place. Thus, while they can appear as far away from the verb as the nearest complementizer, e.g.,

- (6.27) a. Wiemy tylko to, [ $\bar{S}$  że tam wczoraj byliście].  
                     we-know only this that there yesterday you-were(2nd/PL)  
                     'We know only that you were there yesterday.'  
                     b. Wiemy tylko to, [ $\bar{S}$  żeście tam wczoraj byli].

they cannot appear attached to an element beyond it:

(6.28) \* Wiemy tylkoście, [ $\bar{S}$  że tam wczoraj byli].

Now, returning to our data in (6.24), we can ask whether or not verbal suffixes can be attached to *bo*, etc. As (6.29) and (6.30) illustrate for just two of those items, they can. In (6.29a) and (6.30a), I give the neutral examples, where the suffixes are attached to the verb.<sup>6</sup>

(6.29) a. Spóźniliście się na koncert, bo  
 you-were-late PRT for concert because  
 ogądaliście film.  
 you-watched(2nd/PL) film

b. Spóźniliście się na koncert, boście oglądali film.

(6.30) a. Przeczytam te listy, chociaż je już raz  
 I'll-read these letters although them already once  
 czytałam.  
 I-read(1st/SG)

b. Przeczytam te listy, chociażem je już raz czytała.

Given that the suffixes cannot appear outside the minimal  $\bar{S}$  that contains the verb with which they are associated in the first place, and given the fact that they appear with the items in question, we must conclude that these items are complementizers and not prepositions. If they were prepositions, they would be outside the  $\bar{S}$  (cf. the diagram in (6.25b) above). Thus, the CAC's in (6.24) are not PP's. In this case,

then, Polish data are more straightforward than the English data.

#### 6.4. PP's with a modifying clause

##### 6.4.1. PP's with a relative clause

In earlier discussion in this chapter, I identified two examples in Polish of the P-S̄ structure. This structure is, however, comparatively rare. The obvious question to ask is how Polish compensates for this 'deficiency'. The present section will provide an answer to this question.

I shall first look at the structure of a class of CAC's exemplified in (6.31), the first four of which are the counterparts of the English *before-type* CAC's discussed in Chapter 4.

- (6.31) a. Wyszli *przedtem*, *zanim skończył się seans*.  
 they-left beforehand before finished PRT show  
 'They left before the show finished.'
- b. Rower dostaniesz *potem*, *jak zdasz egzamin*.  
 bike you'll-get afterwards when you-pass exam  
 'You'll get a bike after you've passed your exam.'
- c. *Odtąd*, *odkąd tu mieszka*, *z nikim się*  
 since-then since-when here he-lives with nobody PRT  
 nie zaprzyjaźnił.  
 not he-made-friends  
 'He hasn't made any friends since he moved here.'
- d. Pracował *dotąd*, *dokąd starczyło mu sił*.  
 he-worked until-then until-when lasted him energy  
 'He worked as long as his energy lasted.'

- e. *Zdarzyło się to wtedy, kiedy Adam był w wojsku.*  
 happened PRT it then when Adam was in army  
 'It happened when Adam was in the army.'
- f. *Stań tu, gdzie ja stoję.*  
 stand here where I stand  
 'Stand where I'm standing.'
- g. *Schowaj to tam, gdzie trzymasz dokumenty.*  
 hide it there where you-keep documents  
 'Hide it where you keep your documents.'
- h. *Powietrze ucieka stąd, skąd wystaje gwóźdź.*  
 air escapes from-here from-where sticks-out nail  
 'Air is escaping from where the nail is sticking out.'
- i. *Czytaj odtąd, odkąd inni czytali.*  
 read from-here from-where others read  
 'Read from where the others read.'
- j. *Doszli dotąd, dokąd zaprowadziła ich ścieżka.*  
 they-went to-here to-where lead them path  
 'They went to where the path lead them.'

As we can see, these CAC's are introduced by the temporal and spatial demonstratives, discussed in Chapter 2. The clauses following them are introduced by a variety of items: complementizers (*zanim* 'before' and *jak* 'how' in the sense of 'when') and *wh*-words (e.g. *odkąd* 'since-when' and *gdzie* 'where'). The latter correspond to the preceding demonstratives in their meaning and, in some cases, in their form (e.g. *skąd* 'from-where' -- *stąd* 'from-here').

In the Polish literature, the demonstratives in such constructions are known as 'correlatives' (*korelaty*; cf. Polański 1968: 291, Topolińska 1984a: 345) or 'junction markers' (*wskazniki zespolenia*; cf.

Klemensiewicz 1957: 73). These terms refer to their function in a sentence, which is the introduction of a subordinate clause. The category status of the 'correlatives' in CAC's is assumed to be 'adverb' or 'pronoun' -- just as when they appear on their own in a sentence as simple temporal and spatial adverbials. The clauses following the 'correlatives' are usually regarded as relative clauses. However, for Klemensiewicz (1957: 89), only those clauses which are introduced by a *wh*-word are relative clauses. Those introduced by *zanim* and *jak* are 'conjunction clauses' (*wypowiedzenia spójnikowe*).

In Chapter 2 (pp. 45-48), I argued that demonstratives like those in (6.31) are of the category 'preposition' rather than 'adverb' or 'pronoun'. Following this argument, I assume that they are also prepositions in CAC's. Unlike Klemensiewicz, I regard all the clauses in these constructions as relative clauses. Thus, the structure of the CAC's in (6.31) is as presented in (6.32) below. I use the string *wtedy*, *kiedy Adam był w wojsku* 'when Adam was in the army' in (6.31e) for the purpose of illustration.

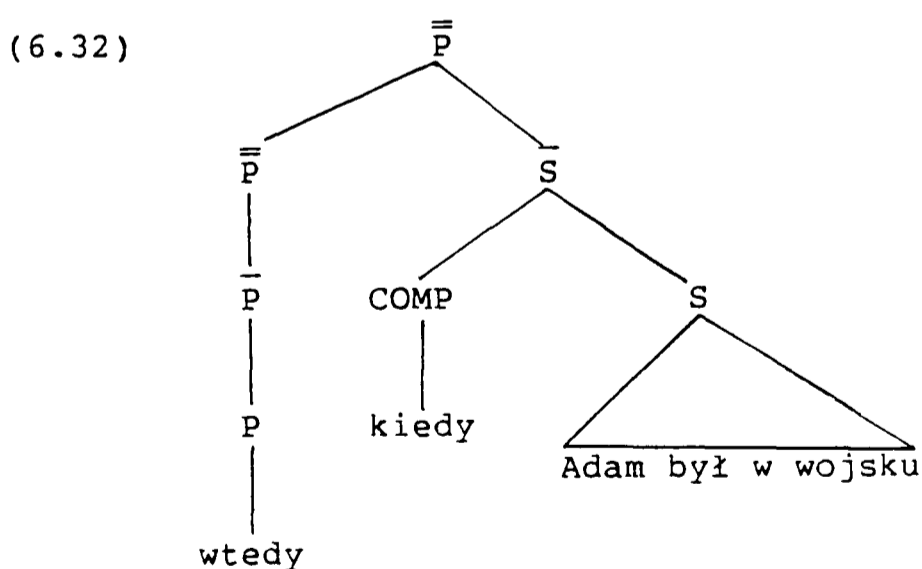

To illustrate the relative construction properties of these CAC's, I shall compare them with a more typical relative construction, which involves an NP headed by the demonstrative pronoun to 'this' as in (6.33).

(6.33) Kupili to, co widzieli wczoraj na wystawie.

they-bought this what they-saw yesterday on display

'They bought what they saw on display yesterday.'

First, relative clauses are optional. In their presence, the interpretation of the demonstrative depends on the following clause, and in their absence, on the preceding linguistic context or on the non-linguistic context, e.g.:

(6.34) a. Zobacz! To kupili.

look this they-bought

b. Wykłady zaczynały się dopiero w styczniu, ale studenci

lectures began PRT only in January but students

kupili książki przedtem.

bought books beforehand

c. Z opony wystaje gwóźdź. Stąd ucieka powietrze.

from tyre sticks-out nail from-here escapes air

Secondly, the clauses contain a *wh*-word or -- in the case of *zanim* and *jak* -- a specialized complementizer. (6.35) and (6.36) illustrate that *co* 'what' and all but these two clause-initial items from (6.31) can appear in *wh*-questions corresponding to the relative clauses.

(6.35) Co widzieli wczoraj na wystawie?

'What did they see on display yesterday?' (cf. (6.33))

(6.36) a. Odkąd on tu mieszka?

'Since when has he been living here?' (cf. (6.31c))

b. Dokąd starczyło mu sił?

'How long did his energy last?' (cf. (6.31d))

- c. *Kiedy* Adam był w wojsku?  
       'When was Adam in the army?' (cf. (6.31e))
- d. *Gdzie* stoję?  
       'Where am I standing?' (cf. (6.31f))
- e. *Gdzie* trzymasz dokumenty?  
       'Where do you keep your documents?' (cf. (6.31g))
- f. *Skąd* wystaje gwóźdź?  
       'From where is the nail sticking out?' (cf. (6.31h))
- g. *Odkąd* inni czytali?  
       'From where did the others read?' (cf. (6.31i))
- h. *Dokąd* zaprowadziła ich ścieżka?  
       'Where did the path lead them to?' (cf. (6.31j))
- i. \* *Zanim* skończył się seans?  
       before finished PRT show (cf. (6.31a))
- j. (\*) *Jak* zdasz egzamin?  
       when you'll-pass exam (cf. (6.31b))

As we have already seen (p. 165), *jak* can only appear in questions asking about manner but not time, though it can appear in other relative clauses with a temporal interpretation (cf. (6.17) above).<sup>7</sup> The occurrence of *zanim* is restricted to contexts in which *przedtem* can appear. However, both *zanim* and *jak* following *przedtem* and *potem*, respectively, can be replaced by the *wh*-word *kiedy* 'when'. Thus, corresponding to (6.31a) and (6.31b), we have the examples in (6.37).

- (6.37) a. Wyszli *przedtem*, *kiedy* skończył się seans. (cf. (6.31a))  
       b. Dostaniesz rower *potem*, *kiedy* zdasz egzamin. (cf. (6.31b))

It seems appropriate, then, to regard *zanim* and *jak* in CAC's as specialized relative complementizers.

The third, and last, relevant characteristic shared by the *to*-construction and the CAC's is that in addition to the restrictive interpretation, they also have a non-restrictive interpretation, given a distinctive comma intonation (cf. note 1 to this chapter). Most of the English glosses in (6.31) convey this interpretation.

It is evident, then, that these CAC's involve relative clauses. Since the items which the relative clauses modify are (intransitive) prepositions elsewhere, it is natural to assume that they are prepositions here and hence, that the structure of the CAC's is as in (6.32).

However, since relative clauses normally modify NP's, one might have some doubts about an analysis in which they modify PP's. But such doubts are ill-founded because -- independently of these CAC's -- relative clauses are not limited to modifying NP's in Polish. The relevant examples are presented in (6.38).

(6.38) a. *Ich dzieci są takie, jaki był dziadek.*

their children are such what was granddad

'Their children are like granddad was.'

b. *Anna gra na skrzypcach tak, jak grają zawodowcy.*

Anna plays on violin so how play professionals

'Anna plays the violin as the professionals do.'

Here, we have a demonstrative pro-adjective *taki* 'such' and a demonstrative pro-adverb *tak* 'so' followed by clauses introduced by *jaki* 'what' and *jak* 'how', respectively. (6.39) illustrates that these are *wh*-words, as they can appear in *wh*-questions.

(6.39) a. *Jaki był dziadek?*

'What was granddad like?' (cf. (6.38a))

b. *Jak grają zawodowcy?*

How do the professionals play? (cf. (6.38b))

Like the clauses in the *to-* and *przedtem-*constructions, the clauses in (6.38) are optional, e.g.,

(6.40) a. *Ich dzieci są takie.*

'Their children are such.'

b. *Anna tak gra na skrzypcach.*

'Anna plays the violin this way.'

and they can have a non-restrictive as well as a restrictive interpretation.

These constructions, then, are further instances of non-NP relatives: an AP and an ADVP.

While it is accepted in the Polish literature that not only NP's but also demonstrative AP's and ADVP's can participate in the relative clause construction, the inclusion of PP's is a novel proposal. However, this addition is not unexpected from the standpoint of X-bar Theory, whose major assumption is that certain syntactic phenomena occur cross-categorially.

As it happens, English does not fully exploit the potential in this area, but Polish clearly does.<sup>8</sup> In English, intransitive prepositions can only be antecedents of non-restrictive relative constructions, e.g.:

(6.41) They bought the books *beforehand*, *when they were in Oxford*.

#### 6.4.2. PP's with an appositive clause

The last type of construction to consider is illustrated in (6.42).

(6.42) a. Wyjechał *dlatego*, że stracił pracę.

he-left therefore that he-lost work

'He left because he'd lost his job.'

b. Poszedł do lekarza *dlatego*, bo był chory.

he-went to doctor therefore because he-was ill

'He went to the doctor because he was ill.'

This consists of a demonstrative pro-form *dlatego* 'therefore' and a clause introduced by a complementizer. In addition to *że* 'that' and *bo* 'because', *iż* 'that' and *ponieważ* 'since' can also follow *dlatego*. In *dlatego*, one can easily distinguish the preposition *dla* 'for', which requires a genitive NP complement (e.g. *prezent dla Anny* 'a present for Anna(GEN)'), and the element *tego*, which looks like the genitive form of the demonstrative *to* 'this'.

As was the case with the demonstratives considered above, the clause is optional and the interpretation of *dlatego* depends on the clause when it is present and on the context when the clause is absent. The clause contains a complementizer rather than a *wh*-word and there is no ambiguity between a restrictive and a non-restrictive interpretation of the construction. A CAC introduced by *dlatego* does, however, acquire the characteristics of a relative construction when the *wh*-word *dla czego* 'why' takes the place of the complementizer in sentences like the following:

(6.43) Poszedł do lekarza *dlatego*, *dlatego* ty *poszedłeś*.

he-went to doctor therefore why you went

'He went to the doctor for the same reason as you  
went there.'

Two analyses of CAC's like those in (6.42) have been advanced by Polish linguists. According to Klemensiewicz (1957: 74, 93-94), *dlatego* is another 'junction marker', a pronoun (1969: 12), and the clause is a non-relative 'conjunction' clause. On the other hand, according to Walczak (1975: 59) and Grochowski (1977: 20-21), such CAC's involve a complex conjunction *dlatego że*. (Grochowski's (1984a: 295) list of conjunctions includes also *dlatego iż* though not *dlatego bo* or *dlatego ponieważ*.)

Let me first briefly discuss the second of these analyses. My objections to it are essentially the same as they were to analyzing *mimo* and *że*, and *podczas* and *gdy* as complex conjunctions.

First, by postulating complex conjunctions, the authors extend the lexicon by complex items whose components must be included there independently.

Secondly, the possibility of coordination of the complementizer and the clause following *dlatego* with a similar string, illustrated in (6.44) below, suggests that the complementizer and the clause form a constituent, an  $\bar{S}$ .

- (6.44) Grał w karty dlatego, że się nudził  
 he-played in cards therefore that PRT he-bored  
 i że chciał szybko dużo zarobić.  
 and that he-wanted quickly much earn  
 'He was playing cards because he was bored and because he  
 wanted to earn much quickly.'

Thirdly, as Grochowski (1977: 20) himself notes, *dlatego* and *że* (or *iż*) need not be adjacent. He offers the following example to illustrate this point:

- (6.45) *Dlatego grał w karty, że się nudził.*

Both these pieces of data are incompatible with the 'complex conjunction' analysis.<sup>9</sup> It seems, then, that Klemensiewicz's is a preferable analysis.

I agree with Klemensiewicz that the clause following *dlatego* in (6.42) is a non-relative clause. Following Quirk et al. (1985: 1244), I refer to such clauses as 'appositive' clauses. However, I disagree with Klemensiewicz about the category status of *dlatego* and hence, the category status of the whole CAC, given the natural assumption that *dlatego* is its head. If -- as Klemensiewicz claims -- *dlatego* were a pronoun, one would expect non-pronominal NP's to appear in positions where it can appear. There is only one such position, adverbial (of reason). As (6.46) illustrates, *dlatego* can alternate with PP's but not with NP's there.<sup>10</sup>

|                           |   |  |
|---------------------------|---|--|
| (6.46) Anna zdała egzamin | } | <i>dlatego.</i><br><i>z tego powodu.</i><br><i>dzięki pilnej nauce.</i><br><i>* tym powodem.</i><br><i>* pilnej nauki.</i> |
| Anna passed exam          | } | therefore<br>for this reason<br>thanks to diligent study<br>this reason(INST)<br>diligent study(GEN)                       |

Because the distribution of *dlatego* and NP's is not the same, it is unlikely that it is a pronoun. Because its distribution is the same as the distribution of PP's, it is more appropriate to regard it as another (intransitive) preposition.

As a preposition, *dlatego* in examples like (6.42) will be the head of a PP with a structure rather like that of the relative clause construction (cf. the diagram in (6.32) above), as in both cases the clause is a modifying clause. In (6.47) below, the string *dlatego, że stracił pracę* 'because he'd lost his job' from (6.42a) above is used for the purpose of illustration.

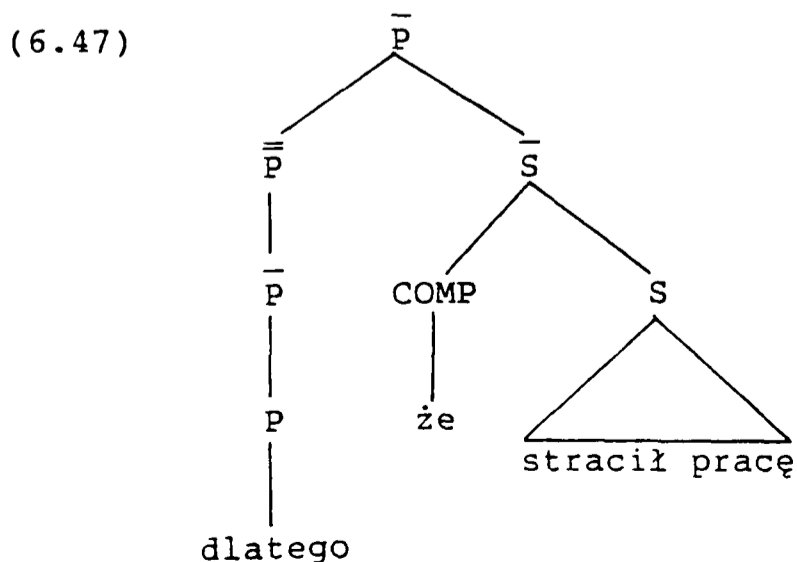

In assuming this analysis, we add a demonstrative of the category 'preposition' to the demonstratives of the other categories which can appear in this type of construction. As illustrated in (6.48), the pro-forms associated with the category 'noun' (to 'this'), 'adjective' (*taki* 'such'), and 'adverb' (*tak* 'so') can be followed by an appositive clause.

(6.48) a. *Jestem pewna tego, że Anna zda egzamin.*

I-am sure this that Anna will-pass exam

'I'm sure that Anna will pass the exam.'

b. *Ich dzieci są takie, że wszystko jedzą.*

their children are such that all they-eat

'Their children are such that they eat everything.'

c. *Zrobili to tak, że wszystkim zaimponowali.*

they-did it so that all they-impressed

'They did it in such a way that everybody was impressed.'

Thus, considerations of a cross-categorial generalization emerging from the proposed analysis lends some further support to this analysis.

Finally, we turn to some further data, which include counterparts of the straightforward English examples with the P- $\bar{S}$  structure discussed in Chapter 4 (pp. 125-129):

(6.49) a. *Oni byli nierozsądni w tym, że zwlekali z*

they were unreasonable in this(LOC) that they-delayed with  
*budową domu.*

building house

'They were unreasonable in that they delayed the building  
of the house.'

b. *Zastanawia się nad tym, jak ułożyć list.*

he-wonders PRT over this(INST) how compose letter

'He's wondering about how to compose the letter.'

c. *Pojechali w góry mimo to, że zgubili*

they-went in mountains despite this(ACC) that they-lost

*narty.*

skis

'They went to the mountains despite the fact that they'd

lost their skis.'

In these examples, we have complex constructions (complements and adverbials) consisting of a preposition followed by the demonstrative pronoun to 'this' in an appropriate case form, followed by a modifying clause with a complementizer or a *wh*-word. The clauses have a non-relative interpretation. Hence, they are appositive clauses. Various other prepositions can appear in such strings.

Since the case marking of the demonstrative depends on the preposition and since *to* on its own can introduce appositive clauses in other environments (cf. (6.48a) above, where *to* and a clause follow an adjective and where there is no preposition immediately preceding *to*), it might be thought that the italicized strings in (6.49) form a PP with a complex NP complement such as illustrated in (6.50) below. The string *w tym, że zwlekali z budową domu* 'in that they delayed the building of the house' in (6.49a) is used for the purpose of illustration.

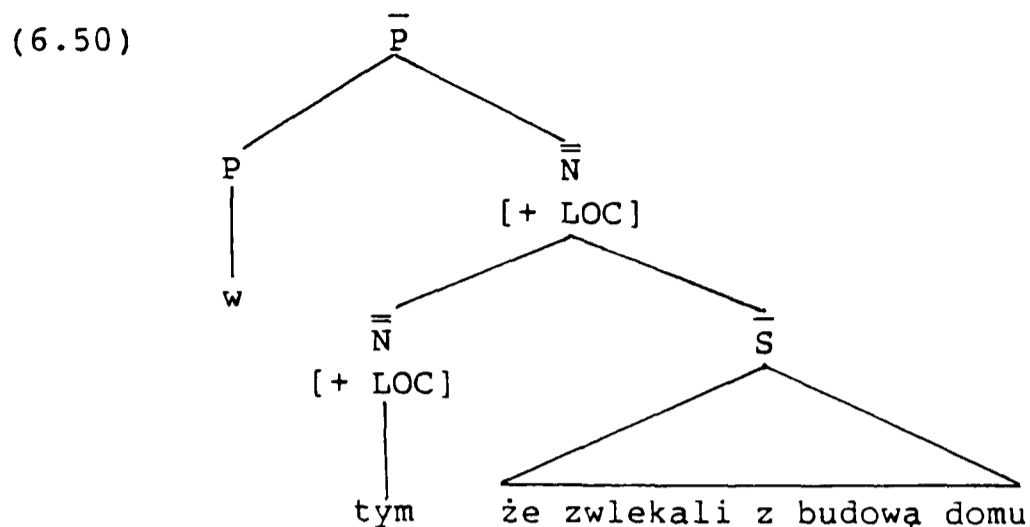

This analysis predicts, however, that *to* with the following clause can be conjoined with another similar string. The example in (6.51) shows that the prediction is false.

- (6.51) \* *Oni byli nierozsądni w tym, że zwlekali z budową domu i tym, że nie kupili mebli.*  
 they were unreasonable in this that they-delayed with building house and this that not they-bought furniture

An alternative that suggests itself is that the prepositions *and to* in constructions like (6.49) are further instances of intransitive prepositions, followed by appositive clauses.<sup>11</sup>

This appears to extend the lexicon by a large number of complex intransitive prepositions. In view of the fact that their components must be represented in the lexicon independently, it looks like an objectionable proposal. However, given that *to* can appear with, I think, any transitive preposition in this construction, we can simplify the lexicon by postulating a 'lexical redundancy rule', which will state that for every transitive preposition there is a corresponding intransitive demonstrative preposition of the form *P-to*. Thus, the implication of the proposed analysis for the lexicon is not as severe as

it might appear to be.

### 6.5. Conclusion

In this chapter, I have argued that there are at least two Polish prepositions that can take an  $\bar{S}$  complement: *mimo* 'despite' and *podczas* 'during'. *Mimo* takes a clause with an ordinary complementizer and *podczas* takes a clause introduced by items which are normally associated with *wh*-movement. Both types of clausal complement occur in English but there is no one-to-one correspondence between the items involved.

I then showed that there is no basis for analyzing certain other Polish CAC's as PP's because the clause-initial elements are clearly complementizers. Thus, Emonds' (1976) and Jackendoff's (1977) position that all but a few subordinating conjunctions should be analyzed as prepositions is not sustained by the Polish data.

Finally, I investigated two other types of CAC's. Building on my earlier case for analyzing spatial and temporal demonstratives as intransitive prepositions, I suggested that the CAC's that they introduce are PP's containing a relative clause. I then suggested that other CAC's (and some complements) consist of an intransitive preposition and an appositive clause, which either does or does not involve *wh*-movement. Some of the English counterparts of these constructions have the  $P-\bar{S}$  structure. As far as I can see, there are no PP's with the same structure in English.

The adverbial PP's discussed in this chapter fall into four categories with respect to the kind of clause that they contain. The following table presents a rough classification of the constructions discussed.

|                                    | COMPLEMENT                 | NON-COMPLEMENT                    |
|------------------------------------|----------------------------|-----------------------------------|
| <i>wh</i> -movement<br>clause      | <i>podczas</i> + $\bar{S}$ | <i>przedtem</i> , etc.+ $\bar{S}$ |
| non- <i>wh</i> -movement<br>clause | <i>mimo</i> + $\bar{S}$    | <i>dlatego</i> , etc.+ $\bar{S}$  |

Table 6.1.  
Complex adverbial PP's in Polish

Given that there are prepositions in Polish that can take an  $\bar{S}$  complement, an analysis of PP's in which they are non-heads within an NP is further undermined. In the light of the objections to this analysis presented in Chapter 1 (pp. 27-29) and in the light of the empirical arguments against it advanced in Chapters 2 and 5, I conclude that the case against regarding Polish prepositions as non-heads and in favour of regarding them as heads is a strong one.

## NOTES TO CHAPTER 6

1. In Polish orthography, all subordinate clauses are usually preceded by a comma, not only those that are marked by a 'comma intonation'. In the case of *mimo* followed by a clause, however, it is recommended that a comma is put immediately before *mimo* rather than the complementizer *że* (cf. Jodłowski and Taszycki 1972: 177).
2. In Polish, as in English (cf. n. 12 to Chapter 4 above), a lexical item can separate a preposition from its clausal complement but not a preposition and its NP or PP complement.
3. Clausal constructions introduced by *podczas* can sometimes be ambiguous between temporal and non-temporal interpretation, the latter corresponding to the English *whereas*-clauses. As the English translations indicate, (i) is an ambiguous sentence.

- (i) Adam czytał książkę *podczas*, *gdy* koledzy pisali listy.  
 Adam read book during when friends wrote letters  
 'Adam was reading a book when his friends were writing letters.'  
 'Adam was reading a book whereas his friends were writing letters.'

In my discussion, I refer only to unambiguous examples of temporal *podczas*-clauses.

4. *Jak* can appear in a complement clause such as (i),

- (i) Dyrektor wie, *jak* robotnicy pracują.  
 director knows how workers work

where the clause refers to the manner in which workers work, but not the time when they work (cf. also (6.19) above).

5. The person and number suffixes involved are those of the first and the second person singular and plural. Apart from past tense verbs, the phenomenon involves also the present tense verb *być* 'be' and the defective verb *powinien* 'ought'.
6. For phonological reasons -e- is inserted between the consonant-final *choć* 'although' and the suffix.
7. I have included an asterisk in parentheses in (6.37j) because while this example is unacceptable as a question about time, it is perfectly acceptable as a question about manner, 'How will you pass the exam?'

8. Ojeda 1983 argues that PP's consisting of a preposition and a pronominal element are heads of relative constructions in Spanish. I am grateful to Professor Rebecca Posner for bringing this reference to my attention.

9. In view of the example in (6.45), Grochowski (1977: 20-21) weakens his claim about *dlatego że* by saying that it is a complex conjunction which can sometimes be discontinuous. He likens it to *albo...albo* 'either...or'. However, the comparison seems to be inappropriate because *albo...albo* is always discontinuous. The following illustrate:

- (i) a. *Albo grał w karty albo czytał książki.*  
       either he-played in cards or he-read books  
       b. \* *Grał w karty albo albo czytał książki.*

10. The sentence in (i),

- (i) *Żołnierze przymierali głodem.*  
       soldiers were-dying starvation(INST)  
       'Soldiers were close to death from starvation.'

from Klemensiewicz (1957: 54) might appear to be a counter-example to this claim. It seems, however, that *przymierać głodem* is an idiomatic expression and not an example of a productive construction because *głodem* cannot be replaced by, for example, *pragnieniem* 'thirst(INST)'. The following is unacceptable:

- (ii) \* *Żołnierze przymierali pragnieniem.*

11. According to Klemensiewicz (1969: 12), prepositions and *to* in such constructions form pronouns. The fact that non-pronominal NP's cannot generally appear in positions where the prepositional items can appear argues against this analysis. The fact that ordinary PP's can appear in these positions lends support to the 'intransitive preposition' analysis.

## CHAPTER 7

## PP's IN TYPICAL NP POSITIONS: AN OVERVIEW

7.1. Introduction

In the preceding chapters, my main concern has been with the structure of certain prepositional strings and with the justification of the idea that prepositions are heads of PP's in Polish as well as in English. In this chapter and the next two, I turn to a different aspect of the syntax of PP's, namely, their occurrence as subject and object.<sup>1</sup>

The topic is interesting from both a descriptive and a theoretical point of view. Any standard English or Polish grammar will mention NP as the typical occupant of the subject and object positions, and it will also note that clauses can be subjects and objects (cf., e.g. Quirk et al. 1985: 1047; Szober 1923: 369-370, 371-372).<sup>2</sup> Only a passing reference to English PP's as 'primaries'<sup>3</sup> can be found in Jespersen (1927: 5) and to PP's with 'nominal' function as subjects can be found in Quirk et al. (1985: 658). Examples from Jespersen and Quirk et al. are presented in (7.1) and (7.2), respectively.

- (7.1) a. *From infancy to manhood* is rather a tedious period.  
 b. *From nine to twelve* is three long hours.  
 c. *Between two o'clock and getting up's* the worst time.  
 d. He spent *from eleven to one* at his church.  
 e. I desired *till the next day* to consider it.

- (7.2) a. *Between six and seven* will suit me.  
 b. *On Tuesday* will be fine.  
 c. *In March* suits me.  
 d. *During the vacation* is what we decided.  
 e. *Between six and seven* may be convenient.

I have not encountered comparable examples in work on Polish grammar but the acceptability of sentences like (7.3) suggests that PP's can also be 'primaries' in Polish.

- (7.3) a. *Między szóstą a siódmą* pasowało wszystkim.  
 between six(LOC) and seven(LOC) suited all  
 b. *Od rana do wieczora* zmarnowaliśmy  
 from morning(GEN) to evening(GEN) we-wasted  
 na szukanie ołówka.  
 on searching pencil

PP subjects and objects recall the occurrence of PP's as objects of prepositions in both languages in strings like *from inside the rain barrel* and *do po filmie* 'until after the film' discussed in Chapters 3 and 5, respectively. For Jespersen (1927: 5-9), such PP's are another instance of PP's as 'primaries' and Quirk et al. (1985: 658) cite them as another instance of PP's with a 'nominal' function. The unifying feature of PP's as subjects, objects and objects of prepositions is that they occur in positions with which NP's are usually associated. For this reason, I shall refer to them as 'PP's in typical NP positions'.

Not surprisingly, this phenomenon goes beyond simple active sentences like those in (7.1)-(7.3) above. As (7.4)-(7.7) illustrate, PP's also parallel NP's in their occurrence as subjects in raising and

passive constructions in English and in Polish. The first two examples contain English raising and passive sentences, respectively, and the next two, Polish.

(7.4) a. *This solution* seemed to suit everyone.

b. *After dinner* seemed to suit everyone.

(7.5) a. *All this time* was wasted by the team on the experiment.

b. *From May to September* was wasted by the team on the experiment.

(7.6) a. *To rozwiązanie* wydawało się pasować wszystkim.

'This solution seemed to suit everyone.'

b. *Po obiedzie* wydawało się pasować wszystkim.

'After dinner seemed to suit everyone.'

(7.7) a. *Cały ten czas* został przez nas zmarnowany na szukanie ołówka.

'All this time was wasted by us on trying to find a pencil.'

b. *Od rana do wieczora* zostało przez nas zmarnowane na szukanie ołówka.

'From the morning to the evening was wasted by us on trying to find a pencil.'

As we can see, PP's are used in these unusual functions in a range of constructions, and the phenomenon is not restricted to just only one language. This makes it a matter of some theoretical interest. It would appear that the data cannot be easily accommodated within a category-based approach to sentence structure and that they can be accounted for more satisfactorily within a relational approach, as has been suggested by Richardson (1984: 330-331). In the next chapter, however, I shall develop an analysis of the data within the GB

framework, which is not 'relational' in any obvious sense.

PP's in typical NP positions have so far received little attention from theoretical linguists. In fact, apart from Jackendoff's (1973, 1983) work on PP objects of prepositions, only subject PP's have been considered, though -- as I shall show below -- in a rather limited way. As I proceed, I shall refer to the proposals about subject PP's advanced by Chametzky 1985, Williams (1984: 662-663), and Stowell (1981: 268-269).

In the present chapter, I shall describe the data more fully in theory-neutral terms and spell out some of their implications for grammatical analysis. In Section 7.2, I shall explain why certain PP's must be regarded as subjects and objects. In Section 7.3, I shall discuss the category status of PP's in typical NP positions, and in Section 7.4, I shall identify some semantic and pragmatic properties of the data. Finally, in Section 7.5, I shall consider the data in the light of classical Transformational Grammar -- a transparent example of a category-based framework -- and Relational Grammar -- a transparent example of a relational framework. In the next chapter, I shall develop an analysis of the data within the GB framework and in Chapter 9, I shall consider some further data which lend support to the proposed analysis.

## 7.2. Identifying subject and object PP's

### 7.2.1. Subject PP's in English

In this section, I shall be concerned with the following question: What indicates that PP's in certain sentences should be regarded as subjects and objects rather than adverbials or non-object complements of verbs? I shall first discuss subjects and then objects because the

identification of objects involves reference to subjects. Since the identification of subject PP's in English is based on somewhat different considerations from Polish, I shall discuss the two in separate sub-sections.

The initial PP's in the following English sentences are subjects:

- (7.8) a. *Behind the shed* was swarming with bees.  
 b. *Between six and seven* will suit everyone.  
 c. *Down the road* has changed in appearance since I last visited the town.

These must be distinguished from the initial PP's in the following, stylistically marked sentences:

- (7.9) a. *Behind the shed* was Peter.  
 b. ? *Between six and seven* arrived the Prime Minister.  
 c. *Down the road* went the procession.

These PP's are preposed adverbials and non-object complements, their usual position being after the verb, as illustrated in (7.10)

- (7.10) a. Peter was *behind the shed*.  
 b. The Prime Minister arrived *between six and seven*.  
 c. The procession went *down the road*.

The sentences in (7.10) and (7.8) are stylistically unmarked declaratives. Since English has a fixed subject-verb(-object) word order and since subjects are normally obligatory in finite sentences, the pre-verbal position of the NP's in (7.10) and the PP's in (7.8) provides some indication of the subjecthood of these constituents.

As subjects, the sentence-initial PP's in (7.8) are expected to differ from the sentence-initial PP's in (7.9), which are not subjects. For example, they should follow the auxiliary verbs in yes-no questions. (7.11) shows that they do and (7.12) shows that the PP's in (7.9) cannot.

- (7.11) a. Was *behind the shed* swarming with bees?  
 b. Will *between six and seven* suit everyone?  
 c. Has *down the road* changed in appearance since you  
 last visited the town?

- (7.12) a. \* Was *behind the shed* Peter?  
 b. \* Did *between six and seven* arrive the Prime Minister?  
 c. \* Did *down the road* go the procession?

As subjects, the PP's in (7.8) should occur in raising sentences. This means that while they are the syntactic subject of the main verb, they are understood as the subject of the following infinitive. (7.13) contains raising sentences related to (7.8).

- (7.13) a. *Behind the shed* appeared to be swarming with bees.  
 b. *Between six and seven* is certain to suit everyone.  
 c. *Down the road* seems to have changed a lot since  
 I last visited the town.

(7.14), on the other hand, shows that the initial PP's in (7.9) cannot occur in raising constructions.

- (7.14) a. \* *Behind the shed* appeared to be Peter.  
 b. \* *Between six and seven* was certain to arrive the  
       Prime Minister.  
 c. \* *Down the road* seems to have gone the procession.

Finally, as subjects, the PP's in (7.8) should be able to appear in coordinate constructions, conjoined with subject NP's. This possibility should not be available to the PP's in (7.9), which are not subjects and should not be able to be conjoined with subjects. As (7.15) and (7.16) illustrate, both predictions are borne out.<sup>4</sup>

- (7.15) a. *Behind the shed and the shed itself* were swarming  
           with bees.  
 b. Both *between six and seven* and *lunchtime tomorrow*  
       will suit everyone.  
 c. *The outskirts of the city and down the road* have  
       changed in appearance since I last visited the town.

- (7.16) a. \* *This boy and behind the shed* was Peter.  
 b. \* *Between six and seven* and *the taxis* arrived (the  
       Prime Minister).  
 c. \* *Down the road and the horses* went (the procession).

The fact that PP's in sentences like (7.8) above follow the auxiliary in yes-no questions, appear in raising sentences, and can be conjoined with subject NP's argues strongly that they are subjects.

In some constructions, the function of the sentence-initial PP is ambiguous between subject and non-subject. As it happens, these are the most frequently cited examples of subject PP's. In (7.17), we have an

example from Safir (1983: 731).

(7.17) *Under the bed is a cosy spot.* (= S's (3))

The following paraphrases convey the two interpretations of this sentence:

(7.18) a. *The whole area under the bed is a cosy spot.*

b. *There is a cosy spot somewhere under the bed.*

Interpreted as (7.18a), the sentence in (7.17) is a construction with a PP subject. For example, as a subject, it follows the verb in a question:

(7.19) *Is under the bed a cosy spot?*

In contrast to the declarative sentence in (7.17), this question is unambiguous: an interpretation related to (7.18b) cannot be associated with it.

As a subject, the PP in (7.17) can be conjoined with another (NP) subject, as (7.20) illustrates.

(7.20) *This corner and under the bed are quite cosy spots.*

Here too no ambiguity arises.

Interpreted as (7.18b), (7.17) is a sentence with a latent dummy subject *there* (cf. Postal 1977: 147-151). In (7.21), *there* is explicit and the sentence is unambiguous.

(7.21) *Under the bed, there is a cosy spot.*

The implicit presence of the subject *there* in (7.17) under this interpretation rules out the possibility that the PP itself is a subject. Rather, it is a preposed PP in topic position.<sup>5</sup> The fact that

this interpretation is not associated with the question in (7.19) and with the coordinate construction in (7.20) supports this analysis.

In raising constructions related to (7.17), such as (7.22),

(7.22) *Under the bed* seems to be a cosy spot.

the role of the PP is also ambiguous. It can either be a raised subject or a preposed PP in a sentence with a raised latent dummy subject. As was the case with (7.17), the presence of *there* disambiguates this sentence:

(7.23) *Under the bed*, there seems to be a cosy spot.

If one of the interpretations of (7.17) implies a latent subject *there*, one might suggest that under the other interpretation, this sentence (and also the sentences in (7.8)) contains a different latent subject, namely *it*, and hence that the PP *there* is not a subject after all. The alternative, 'full' form of (7.17) would then be as in (7.24).

(7.24) ? *Under the bed*, *it* is a cosy spot.

Arguments against this idea are already provided by (7.19) and (7.20), which demonstrate subject properties of the PP. Hence, (7.17) cannot be regarded as involving a preposed PP when it is interpreted as (7.18a).

We can conclude, then, that while some sentence-initial PP's are not subjects, others quite clearly are.

### 7.2.2. Subject PP's in Polish

The identification of subject PP's in Polish involves a somewhat different set of criteria from English because subject-verb inversion does not occur in Polish questions in the way it does in English and because subjectless finite sentences are quite common in this language.

Therefore, before we can identify sentences with subject PP's, we must look at some features of subjectless sentences.

These fall into two broad types, illustrated in (7.25) and (7.26).

(7.25) a. Padało.

was-falling(3rd/SG/NEUT)

'It was raining.'

b. Było                      bardzo wesoło.

was(3rd/SG/NEUT) very      cheerfully

'It was very cheerful there.'

(7.26) W pokoju była                      dziewczynka.

in room      was(3rd/SG/FEM) girl(3rd/SG/FEM)

Bawiła                      się zabawkami.

she-played(3rd/SG/FEM) PRT toys(INST)

'A girl was in the room. She was playing with toys.'

The first type of sentence, (7.25), can be analyzed as involving a null dummy subject, whose English equivalent is the so-called 'expletive' *it* (cf. *It rained*, *It was very cheerful there*). Such sentences are characterized by the third person singular neuter verb form and, in the case of predicative sentences, by an ADVP following the verbs *być* 'be' (cf. Chapter 2, pp. 40-41). They do not allow a lexical nominative NP subject. I illustrate this with (7.27), where the NP is either the demonstrative *to* 'this' or the personal pronoun *ono* 'it'.

(7.27) a. \*  $\left\{ \begin{array}{l} To \\ Ono \end{array} \right\}$  padało.

'This/it kept falling down.'

b. \*  $\left. \begin{array}{l} To \\ Ono \end{array} \right\}$  było bardzo wesoło.

'\* This/it was very cheerfully.'

These examples are unacceptable in the meaning intended, that of (7.25a) and (7.25b), respectively. (7.27a) can only be interpreted as 'Something kept falling down', without implying that any weather-related objects were falling.<sup>6</sup> (7.27b), with *to* or *ono* as its subject, is meaningless. The nearest interpretation that can be assigned to it is 'This/it in itself was very cheerful', but this requires a replacement of the adverb *wesoło* 'cheerfully' with the adjective *wesołe* 'cheerful'. (7.28) is an 'improved' version of (7.27b).

(7.28)  $\left. \begin{array}{l} To \\ Ono \end{array} \right\}$  było bardzo wesołe.

'This/it was very cheerful.'

As we can see, then, subjectless sentences like (7.25) do not allow a lexical subject.

The other type of subjectless sentence, (7.26), involves the so-called 'pro-drop' phenomenon (cf. Chapter 3, p. 68 above). This is the optional omission of a non-dummy (pronominal) subject. As a result, the missing participant in the situation referred to by the sentence must be reconstructed from the context. In (7.26), the second sentence, *Bawiła się zabawkami* '(She) was playing with toys' involves a missing subject, which is the third person singular feminine pronoun *ona* 'she', whose antecedent is *dziewczynka* 'girl' in the preceding sentence. The presence or absence of the subject pronoun does not affect the interpretation of the sentence.

We can now turn to sentences with putative subject PP's:

- (7.29) a. *Bardzo szybko minęło od wtorku do soboty.*  
 very quickly passed from Tuesday to Saturday  
 'From Tuesday to Saturday passed very quickly.'
- b. *Po obiedzie pasowało wszystkim.*  
 after dinner suited all  
 'After dinner suited everyone.'
- c. *Wokół jeziora roiło się od wczasowiczów.*  
 around lake swarmed PRT from holiday-makers  
 'Around the lake was swarming with holiday-makers.'
- d. *Pod schodami jest dobrą kryjówką.*  
 under stairs is good hiding-place  
 'Under the stairs is a good hiding-place.'

To establish that these PP's are subjects, we must first discard the possibility that they are (optional) adverbials in one or the other type of subjectless sentence.

If the examples in (7.29) were sentences with a null dummy subject, it should not be possible for a nominative NP to appear in them. As (7.30) shows, a nominative NP can appear in these sentences.<sup>7</sup>

- (7.30) a. *Zebranie minęło bardzo szybko.*  
 meeting(NOM) passed very quickly
- b. *To popołudnie pasowało wszystkim.*  
 that afternoon(NOM) suited all
- c. *Uzdrowisko roiło się od wczasowiczów.*  
 resort(NOM) swarmed PRT from holiday-makers

d. *Biurko* było dobrą kryjówką.

desk(NOM) was good hiding-place

Since the sentences in (7.29) allow a lexical subject, they cannot be regarded as subjectless sentences with a null dummy subject.

Could they be subjectless sentences of the second type, then, related to (7.30), with a pronominal subject unrealized, as in (7.31)?

(7.31) a. *Minęło* nam bardzo szybko.

b. *Pasowało* wszystkim.

c. *Roiło* się od wczasowiczów.

d. *Było* dobrą kryjówką.

It seems not. A comparison of (7.31) with (7.29), where the PP's are present, reveals an important difference: whereas in isolation, the sentences in (7.31) require a context to identify one of the participants in the situation, no such context is required for (7.29). Since subjects are missing from (7.31), it is arguable that the PP's in (7.29) are the missing subjects.

Further evidence for their status as subjects is provided by the fact that they can be conjoined with nominative NP's:

(7.32) a. *Od wtorku do soboty i całe Święta* minęły

from Tuesday to Saturday and whole Christmas(NOM) passed

bardzo szybko.

very quickly

b. *Przedpołudnie i po obiedzie* pasowały wszystkim.

morning(NOM) and after dinner suited everyone

c. *Wokół jeziora i polana* roiły się od  
 around lake and clearing(NOM) swarmed PRT from  
 wczasowiczów.  
 holiday-makers

d. *Pod schodami i piwnica* były dobrymi kryjówkami.  
 under stairs and cellar(NOM) were good hiding-places

If the PP's are subjects in (7.29), it follows that, like their English counterparts in (7.8) above, they are subjects in raising sentences like (7.33)

(7.33) a. *Od wtorku do soboty* wydawało się minąć bardzo szybko.

'From Tuesday to Saturday seemed to have passed very quickly.'

b. *Po obiedzie* wydawało się pasować wszystkim.

'After dinner seemed to suit everyone.'

c. *Wokół jeziora* wydaje się roić od wczasowiczów.

'Around the lake seems to be swarming with holiday-makers.'

d. *Pod schodami* wydaje się być dobrą kryjówką.

'Behind the cupboard seems to be a good hiding-place.'

One further piece of evidence for the status of these PP's as subjects comes from a consideration of *wh*-questions like (7.34), which the sentences in (7.29) might be answers to.

(7.34) a. *Co* minęło wam bardzo szybko?

'What passed quickly to you?'

b. *Co* pasowało wszystkim?

'What suited everyone?'

c. Co roiło się od wczasowiczów?

'What was swarming with holiday-makers?'

d. Co było dobrą kryjówką?

'What was a good hiding-place?'

As the English translations indicate, these are questions about subjects, with the pronominal *wh*-word *co* 'what'. *Co* is in the nominative case. In contrast, in order to question the PP's in sentences like (7.35), where they are adverbials,

(7.35) a. *Od wtorku do soboty bawiła się nowymi zabawkami*

'From Tuesday to Saturday, (she) played with new toys.'

b. *Wokół jeziora postawili namioty.*

'Around the lake, (they) put up tents.'

we must use the adverbial question words *kiedy* 'when' and *gdzie* 'where', not *co*. The following illustrate:

(7.36) a. *Kiedy* } bawiła się klockami?  
\* *Co* }

'When/\*What did she play with building blocks?'

b. *Gdzie* } postawili namioty?  
\* *Co* }

'Where/\*What did they put up tents?'

Even when the adverbial is an NP rather than a PP, as in (7.37a), the question word cannot be *co*.

(7.37) a. *Tej wiosny dzieci chorowały.*

this spring(GEN) children were-ill

|                 |   |                          |
|-----------------|---|--------------------------|
| b. <i>Kiedy</i> | } | <i>dzieci chorowały?</i> |
| * <i>Czego</i>  |   |                          |
| when            | } | children were-ill        |
| what(GEN)       |   |                          |

As follows from the English translations and glosses of the Polish examples in (7.34)-(7.37), the same pattern occurs in English. Thus, both *co-* and *what-*questions provide some additional evidence for the subject status of certain PP's in the respective languages.

### 7.2.3. Object PP's

Linguists of various persuasions agree that objects can be successfully identified by means of reference to the active-passive relation between sentences (Jespersen 1914: 9; Allerton 1982: 82; Bresnan 1982: 8; Jodłowski 1976: 98). The principle is very simple: a constituent is an object in an active sentence if it is a subject in the corresponding passive sentence.<sup>8</sup> The subject of a passive sentence is understood in the same way as the object in the corresponding active sentence. (7.38) and (7.39) illustrate typical active-passive pairs in English and Polish.

(7.38) a. Ann cured *the children*.

b. *The children* were cured (by Ann).

(7.39) a. Anna leczyła *dzieci*.

Anna cured children

b. *Dzieci* były leczone (przez Annę).

children were cured by Anna

Given this test, the italicized PP's in (7.40) and (7.41) will be identified as objects if it can be shown that they are subjects in the corresponding passive sentences.

(7.40) a. The police examined *behind the shed*.

b. The team wasted *from May to September* on the experiment.

(7.41) a. Milicja przeszukiwała *wokół garażu* w poszukiwaniu

militia seached around garage(GEN) in search

śladów włamania.

clues burglary

'The militia was examining around the garage in search for

clues to the burglary.'

b. *Od rana do wieczora* zmarnowaliśmy na szukanie ołówka.

'We wasted from the morning to the evening on trying

to find a pencil.'

(= (7.3b))

The passive counterparts of these sentences are presented in (7.42) and (7.43), respectively.

(7.42) a. *Behind the shed* was examined by the police.

b. *From May to September* was wasted by the team on

the experiment.

(= (7.5b))

(7.43) a. *Wokół garażu* było przeszukiwane przez milicję.

around garage was searched by militia

- b. *Od rana do wieczora* zostało zmarnowane na szukanie  
 from morning to evening. became wasted on searching  
*ołówka.*  
 pencil (= (7.7b))

As the next set of examples illustrates, the PP's in the above English passive sentences participate in subject-verb inversion in questions, occur in raising constructions, and can be conjoined with a subject NP.

- (7.44) a. *Was behind the shed* examined by the police?  
 b. *Was from May to September* wasted by the team on the  
 experiment?

- (7.45) a. *Behind the shed* seems to have been examined by the  
 police.  
 b. *From May to September* appears to have been wasted by  
 the team on the experiment.

- (7.46) a. *All this side of the garden and behind the shed* were  
 examined by the plice.  
 b. *The previous term and from May to September* were  
 wasted by the team on the experiment.

This indicates that the PP's in (7.42) are subjects and hence that the PP's in (7.40) are objects.

The PP's in the Polish passives in (7.43) can be conjoined with a nominative NP and they can appear in raising sentences. The following illustrate:

- (7.47) a. *Jadalnia* i *wokół garażu* były przeszukiwane  
 dining-room(NOM) and around garage were searched  
 przez milicję.  
 by militia
- b. *Od rana do wieczora* i *wolna sobota* zostały  
 from morning to evening and free Saturday(NOM) became  
 zmarnowane na szukanie ołówka.  
 wasted on search pencil

- (7.48) a. *Wokół garażu* wydawało się być przeszukiwane przez milicję.  
 around garage seemed PRT be searched by militia
- b. *Od rana do wieczora* wydawało się zostać zmarnowane  
 from morning to evening seemed PRT become wasted  
 na szukanie ołówka.  
 on search pencil

Like their English counterparts, then, these PP's are subjects in the passives in (7.43) above. The implication is that they are objects in the active sentences in (7.41).

### 7.3. The category status of subject and object PP's

In Chapter 3 (pp. 65-70), I argued that PP objects of prepositions in English are bare PP's and not PP's embedded in an NP. In Chapter 5, I tacitly assumed this also to be the case in Polish. Other things being equal, subject and object PP's -- two other instances of a PP in typical NP positions -- should also be bare PP's in both languages. Since no unified account of this aspect of the distribution of PP's has been attempted, this argument has not been advanced before.

It has, however, been suggested with reference to English data that subject PP's are immediately and exhaustively dominated by NP in structures like the following (Williams 1984: 662-663):

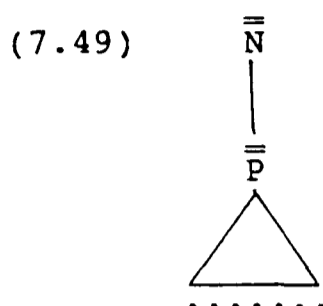

Williams admits that such a structure is undesirable in principle since it is incompatible with a restrictive version of X-bar Theory, in which every phrasal category must have a head. However, he considers it as a product of 'a rule with a highly specialized utility, confined to copular constructions' (1984: 663). An implicit assumption here seems to be that violations of a restrictive version of X-bar Theory might be permissible, provided they appear in limited, clearly defined contexts. It is obvious, however, that the rule generating the structure in (7.49) would have a wider application than Williams presupposes.

First, PP's can be subjects not only in copular constructions (i.e. with verbs like *be* and *seem*) but also in non-copular constructions (i.e. with verbs like *suit* and *pass*).

Secondly, Williams' rule would have to be invoked to generate PP's in object position and also, presumably, PP objects of prepositions.<sup>9</sup> As a result, the claim that the rule has 'specialized utility' is difficult to defend.

Furthermore, structures like (7.49) have been explicitly rejected by Emonds (1976: 15-16) and independently criticized by Richardson 1984.<sup>10</sup> Richardson objects to the way various linguists analyze as NP's any type of constituent ( $\bar{S}$ , PP, AP, etc.) that occurs in a typical NP

position. He points out that this blurs the distinction between the categorial and functional properties of constituents, and strips X-bar Theory of one of its central constraints on phrase structure, namely, that all phrasal categories must have a head.

One might avoid exocentric structures like (7.49) by assuming that the NP has a head noun which is not phonetically realized on the surface. Thus, instead of (7.49), we would have (7.50).

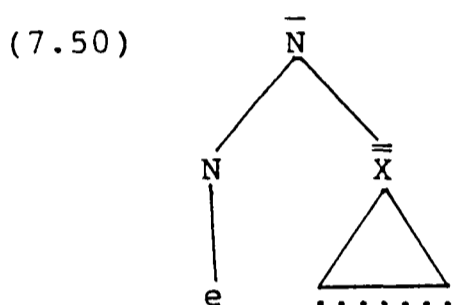

This recalls certain transformational analyses of subject and object clauses (cf. Rosenbaum 1967; Emonds 1976). The empty N might be said to result from the deletion of *it*, *time*, *place*, etc., as appropriate. Such an analysis, however, would meet only the second of Richardson's objections. It would, moreover, violate the restriction on deletion of arbitrary elements (cf. Chapter 3, p. 66), if deletion were assumed. Furthermore, it could not be extended to PP objects of prepositions because of considerations of extraction of a PP complement out of a PP (cf. Chapter 3, pp. 68-70).

It is fair to conclude, then, that subject and object PP's as well as PP objects of prepositions are bare PP's and not PP's embedded in an NP.

#### 7.4. Some characteristics of PP's in typical NP positions

In this section, I shall highlight some semantic properties of PP's in typical NP positions, including PP objects of prepositions, and consider some factors that seem to affect their acceptability. One

previous attempt to discuss these issues, Chametzky 1985, is unsatisfactory because of the author's failure to appreciate the range of the data. Some useful remarks on the semantics of PP objects of prepositions can, however, be found in Jackendoff (1983: 162-165).

Chametzky makes two claims. One is that PP's 'fail to show up in NP positions other than subject' (1985: 31). In the light of our discussion so far, this is erroneous.

The other claim is that PP's can occur as subjects only in sentences whose predicate 'contains an NP that names the class of denotata which the subject is being used to refer to' (1985: 33). In support of this claim, he cites examples like the following:

- (7.51) a. *Under the bed* makes a nice hiding *place*. (= Ch's (1a))  
 b. *Before lunch* is believed to be a good *time*  
 for the meeting.

In (7.51a), the referent of the subject is 'named', or identified, as 'place' by the head of the predicative NP, *place*. In (7.51b), the subject is identified as 'time' by the noun *time*. The sentences in (7.52), whose predicates do not contain such identifying NP's, show this claim also to be erroneous.

- (7.52) a. Behind the shed was swarming with bees. (= (7.8a))  
 b. *Bardzo szybko minęło od wtorku do soboty*.  
 very quickly passed from Tuesday to Saturday (= (7.29a))

Jackendoff's work is more valuable. He divides spatial and temporal PP's into two broad classes.<sup>11</sup> One of them, exemplified by his examples in (7.53) below, is a class of PP's referring to 'Places'. These consist

of a preposition and an NP referring to a 'Thing' (1983: 162, 164, 189).

The following examples illustrate:

(7.53) in the room; on the table; at 6:00; on my birthday; etc.

The other class, exemplified by his examples in (7.54) below, is a class of PP's referring to 'Paths'. These consist of a preposition and either an NP referring to a Thing, or a PP referring to a Place (1983: 163, 190).

(7.54) a. to the floor; from Tuesday; etc.

b. from under the table; since before midnight; etc.

Of special interest to us are Path PP's of the form P-P-NP in (7.54b). Notice first that all the English and Polish examples whose structure has been argued to be P-PP are PP's of this kind: a path preposition followed by a Place complement. Such PP's are also the easiest to attest (cf. the examples in (3.20) above).

Subject and object PP's can refer either to Places or to Paths. This is illustrated in (7.55) and (7.56), respectively.<sup>12</sup>

(7.55) a. *Between 1940 and 1960 was a good time indeed to*

*read English at Oxford.*

(Rachel Trickett, *The Guardian*, 4.1.1986.)

b. *Milicja przeszukiwała wokół garażu w poszukiwaniu*

*militia searched around garage in search*

*śladów włamania.*

*clues burglary*

(= (7.41a))

(7.56) a. *Until the end of term* was filled by revision.

b. Dyrektor zaplanował do końca kwartału.

director planned until end quarter

'The director has planned until the end of the quarter.'

Like subject NP's, subject PP's must obey selectional restrictions imposed by the predicate. The following examples from English and Polish illustrate:

(7.57) a. *The chair* } attracted his attention.  
           *Under the chair* }

b. *Krzesło* } przykuło jego uwagę.  
       *Pod krzesłem* }

chair } attracted his attention  
 under chair }

(7.58) a. \* { *The chair* } shouted at the patient.  
               { *Under the chair* }

b. \* { *Krzesło* } krzyczało na pacjenta.  
       { *Pod krzesłem* }

chair } shouted on patient  
 under chair }

Like corresponding NP's, object PP's and objects of prepositions must be compatible with the meaning of verbs and prepositions (or with their 'semantic selection' properties, see Chapter 10, Section 10.4 below). For example, the verb *przeszukać* in (7.55b), and its English equivalent *examine* require an object referring to a spatial location. The examples in (7.59), with these verbs followed by temporal objects,

are unacceptable.

(7.59) a. \* The police examined  $\left\{ \begin{array}{l} \textit{midnight} \\ \textit{before midnight} \end{array} \right\}$  in search

for clues to the burglary.

b. \* Milicja przeszukała  $\left\{ \begin{array}{l} \textit{północ} \\ \textit{przed północą} \end{array} \right\}$

militia searched  $\left\{ \begin{array}{l} \textit{midnight} \\ \textit{before midnight} \end{array} \right\}$

w poszukiwaniu śladów włamania.

in search clues burglary

The temporal preposition *until* and its Polish equivalent *do* in (7.60) below require a temporal object. The examples in (7.61), with spatial objects, violate this requirement.

(7.60) a. They argued until  $\left\{ \begin{array}{l} \textit{midnight.} \\ \textit{after midnight.} \end{array} \right\}$

b. Kłócili się do  $\left\{ \begin{array}{l} \textit{północy.} \\ \textit{po północy.} \end{array} \right\}$

they-argued PRT until  $\left\{ \begin{array}{l} \textit{midnight} \\ \textit{after midnight} \end{array} \right\}$

(7.61) a. \* They argued until  $\left\{ \begin{array}{l} \textit{the wall.} \\ \textit{behind the wall.} \end{array} \right\}$

b. \* Kłócili się do  $\left\{ \begin{array}{l} \textit{ściany.} \\ \textit{za ścianą.} \end{array} \right\}$

they-argued PRT until  $\left\{ \begin{array}{l} \textit{wall} \\ \textit{behind wall} \end{array} \right\}$

However, not all PP's that are compatible with selectional restrictions or semantic selection are acceptable in NP positions. It seems that PP's are acceptable in these positions if the intended meaning cannot be expressed by an NP. This claim stems from the following four observations.

First, as Jackendoff (1983: 164) points out, in the English prepositions *into* and *onto*, the 'path' and 'place' meanings are combined in a single lexical item. Thus, the meaning intended by the unacceptable (7.62a) can be expressed better by (7.62b).

(7.62) a. ?\* The mouse ran *to in the hole*.

b. The mouse ran *into the hole*.

The Path-Place meaning expressed by sentences like (7.63a) below, on the other hand, can be expressed only by a sequence of two prepositions. As I show in (7.63b), no appropriate single preposition is available for this purpose.

(7.63) a. He crawled *from under the table*.

b. \* He crawled  $\left\{ \begin{array}{l} \text{fromunder} \\ \text{underfrom} \end{array} \right\}$  the table

In Polish, however, single prepositions expressing the path and place notions are quite common (cf. Chapter 5, pp. 140-141 above). *Spod* 'from-under', *zza* 'from-behind', and *sprzed* 'from-before' are just a few examples. In consequence, Polish has fewer P-P-NP strings that form the P-PP structure than English. It appears, then, that a PP can be object of a preposition if the lexicon lacks a single preposition with a complex meaning.

The second observation concerns cases where the lexicon lacks nouns with certain complex meanings. As (7.64) and (7.65) illustrate, a PP can be used if there is no noun that would express the intended meaning.

(7.64) a. *Under the desk* is a good hiding-place.

b. \* (The) *underdesk* is a good hiding-place.

(7.65) a. *Pod schodami* jest dobrą kryjówką.

under stairs is good hiding-place (= (7.29d))

\* *Podschody* są dobrą kryjówką.

understairs(NOM) are good hiding-place

In the next two examples, the situation is reversed: there is a noun with the intended meaning and a PP is unacceptable:

(7.66) a. \* We need *after noon* for completing this task.

b. We need an *afternoon* for completing this task.

(7.67) a. \* *Potrzebujemy po południu* na wykończenie tego zadania.

we-need after noon for completing this task

b. *Potrzebujemy popołudnie* na wykończenie

we-need afternoon(ACC) for completing

tego zadania.

this task

The third point concerns cases where more than one meaning can be associated with a preposition. Consider the contrast between the Path-Place PP's headed by *from* and *to*, respectively, in sentences like (7.68).

(7.68) a. He crawled *from under the table*.

b. ? He crawled *to under the table*.

As we can see, a PP object occurs less readily with *to* than with *from*. This is probably because certain place prepositions also have a goal meaning. *Under* is one such ambiguous preposition (cf. Jackendoff 1983: 166). Since it can embody the meaning 'goal', *to*, being a goal preposition itself, appears to be redundant in (7.68b). Since *under* cannot embody the meaning 'source', *from* is obligatory in (7.68a) for the intended Path-Place meaning. The omission of *to* from (7.68b) renders the sentence fully acceptable even though it is now ambiguous out of context:

(7.69) He crawled under the table.

It seems that in the attested example (3.20c), repeated in (7.70a), the preposition *to* appears there precisely to prevent the ambiguity of (7.70b).

(7.70) a. [They] moved the camera *to directly above it*. (= (3.20c))

b. [They] moved the camera *directly above it*.

(7.70b) could mean either that the camera was above it all the time it was being moved, or that it was moved from below it to a point above it. The presence of *to* eliminates the first interpretation.

*In front of* in sentences like (7.71),

(7.71) The children ran *to in front of the house*. (cf. (3.28b))

differs from *under* and *above* in that it does not have a goal meaning. Hence, it is quite acceptable in combination with the goal preposition

to.

The fourth and last observation is that the preposition in a PP in a typical NP position must have a definite role to play. In the PP's in (7.72), the second prepositions are redundant and NP's are preferred to PP's, as illustrated in (7.73).

(7.72) a. \* They haven't seen each other *since in May*.

b. \* The cat jumped *from on the desk*.

(7.73) a. They haven't seen each other *since May*.

b. The cat jumped *from the desk*.

The redundant prepositions in (7.72) are *in* and *on*, respectively. In the unmarked case, nouns referring to months have *in* as the associated preposition (cf. nouns referring to days, with which *on* is associated, e.g. *on Monday*), and nouns referring to objects with top surfaces have *on*. These prepositions are implicit in (7.73) above.

In contrast, *before* and *under*, for example, are not associated in this way with these nouns. Therefore, the PP's in (7.74) are acceptable.<sup>13</sup>

(7.74) a. They haven't seen each other *since before May*.

b. The cat jumped *from under the desk*.

There are, then, a variety of factors that affect the acceptability of a semantically appropriate PP (i.e. one compatible with selectional restrictions or semantic selection) in an NP position. It seems, however, that the unacceptable cases of such PP's may be grammatical but should be ruled out by pragmatic constraints. If they were to be ruled out by grammatical constraints, it is not clear to me how the acceptable cases would be accounted for. However, I have no pragmatic account to

offer.

#### 7.5. Some theoretical considerations

In the course of the preceding sections, I have established that in certain sentences, PP's function as subjects and objects, that they and PP objects of prepositions are bare PP's, and that their acceptability depends on semantic and pragmatic factors. I now turn to the formal analysis of the data. In this section, I shall consider how classical Transformational Grammar (TG) and Relational Grammar would handle the data. This is intended as an introduction to the discussion in the next chapter, in which I shall consider the data in the light of GB.

The constructions I am concerned with are as follows:

- (i) simple active sentences with PP subjects
- (ii) active sentences with PP objects
- (iii) PP's with object PP's in any type of sentence
- (iv) raising sentences with PP subjects
- (v) passive sentences with PP subjects

They have all been exemplified in the preceding sections, and further examples will appear shortly. In subsequent discussion, I shall refer only to English data but I shall return to Polish in the next two chapters.

Constructions (i)-(iii) can be accommodated within classical TG in a straightforward way. The standard phrase structure rules for S, VP, and PP introduce NP's as, respectively, subject, object, and object of a preposition. The rules are presented in (7.75).

- (7.75) a. S -----> NP AUX VP  
 b. VP -----> V NP  
 c. PP -----> P NP

The subcategorization features in the lexical entries of verbs like *examine* and of prepositions like *from* contain NP's, which will match the NP positions in structures generated by the phrase structure rules for VP and PP:

- (7.76) a.  $\left[ \begin{array}{c} \textit{examine} \\ \text{V} \\ + \text{ [\_ NP]} \end{array} \right]$                       b.  $\left[ \begin{array}{c} \textit{from} \\ \text{P} \\ + \text{ [\_ NP]} \end{array} \right]$

All we need to do to accommodate our data is to revise the phrase structure rules and the subcategorization statements to allow PP's to figure as alternatives to the NP's. For the purpose of illustration, I revise only the phrase structure rules:

- (7.77) a. S ----->  $\left\{ \begin{array}{l} \text{NP} \\ \text{PP} \end{array} \right\}$  AUX VP  
 b. VP -----> V  $\left\{ \begin{array}{l} \text{NP} \\ \text{PP} \end{array} \right\}$   
 c. PP -----> P  $\left\{ \begin{array}{l} \text{NP} \\ \text{PP} \end{array} \right\}$

With the revised apparatus, sentences like those in (7.78) can easily be generated.

- (7.78) a. [S [pp After dinner] was convenient].  
 b. The police [vp examined [pp behind the shed]]. (= (7.40a))  
 c. The noise came [pp from [pp above the altar]].

A problem arises, however, with raising and passive constructions listed above as (iv) and (v). Let us first look again at some typical examples of these constructions, involving NP's.

(7.79) a. *This solution* seemed to suit everyone. (= (7.4a))

b. *The children* were cured by Ann. (= (7.38b))

The characteristics of these constructions are well-known. In raising sentences, the syntactic subject of the main verb, *seem* in (7.79a), is understood as the subject of the infinitival predicate, complement of *seem*, so that (7.79a) can be paraphrased as *It seems that this solution suited everyone*. In passive sentences, the subject is understood in the same way as it would be if it were the object in a corresponding active sentence, so that (7.79b) can be paraphrased as *Ann cured the children*.

Classical TG transformations generating these constructions are as follows:<sup>14</sup>

(7.80) Subject-raising (it-replacement)

SD: *it* - AUX -  $\left\{ \begin{array}{c} V \\ \text{Copula A} \end{array} \right\}$  - [S NP - X]

1 2 3 4 5

SC: 4 2 3  $\emptyset$  5

(7.81) Passive

SD: NP - AUX - V - NP

1 2 3 4

SC: 4 *be -en* 2 3 (*by* 1)

These formulations specifically refer to NP's (cf. terms 4) as the constituents to be moved by the transformations. These rules will, then, generate sentences like (7.79) above, with subject NP's, but they will

not generate sentences like (7.82), with subject PP's.

(7.82) a. *After dinner* seems to be convenient.

b. *Behind the shed* was examined by the police. (= (7.42))

The obvious revision to these formulations would consist in including PP's as alternatives to NP's in the manner indicated in (7.77). Revised in this way, these rules would generate raising and passive sentences not only with subject NP's but also with subject PP's.

Notice, however, that the structural descriptions for these rules would now also be met by the following strings:

(7.83) a. *it* - PAST - *appear* - [<sub>S</sub> *behind the shed* - be Peter]  
           1          2          3                                  4                                  5

b. *they* - PAST - *look* - *for a solution*  
           1          2          3                  4

These strings could be associated with the following sentences:

(7.84) a. It appeared that *behind the shed* was Peter.

b. They looked *for a solution*.

They could also, however, be the input to the respective transformations, which would derive the following unacceptable constructions:

(7.85) a. \* *Behind the shed* appeared to be Peter. (= (7.14a))

b. \* *For a solution* was looked.

Clearly, the rules in (7.80) and (7.81) with PP's as alternatives to the NP's in terms 4 would lead to overgeneration: any PP would be affected if it were in this position in a string.

The overgeneration might be avoided if some additional mechanism were introduced to distinguish between the PP's that can and cannot be affected. For example, one might mark certain constituents in syntactic structure as 'subjects' and 'objects', and include these relational terms within the formulations of the transformations.

Viewing transformations as operations on constituents with specific grammatical relations is the essence of Relational Grammar (cf. Johnson 1977; Perlmutter 1980). Within this framework, subject-raising consists in the 'advancement' or 'promotion' of the subject of a lower clause to the status of the subject of the main clause. Passivization consists in the promotion of an object to the subject status. Any constituent will be affected by these rules, provided it bears the appropriate grammatical relation. The examples in (7.85), problematic for the category-specific model of classical TG, will not be generated within Relational Grammar because the PP's concerned are, respectively, not a subject in the lower clause and not an object of the corresponding active verb. It is evident, then, that the constructions in (iv) and (v) do not pose a challenge to a relational framework.

## NOTES TO CHAPTER 7

1. Much of the material in these three chapters was included in a paper presented at the Spring Meeting of the Linguistics Association of Great Britain at Salford, 1-3 April, 1985. Jaworska (forthcoming) is based on this paper. I am grateful to Bob Borsley for lengthy discussions of the issues considered here and to Professor Rebecca Posner and an anonymous reviewer of the forthcoming publication for helpful comments and suggestions.
2. Infinitives are also mentioned as possible subjects and objects in work on both languages by, e.g. Quirk et al. (1972: 739-740), Jodłowski (1976: 66), and Bartnicka (1982: 53-54, 231). Like finite clauses, infinitives are S's in GB (cf. Chapter 4, p. 112).
3. By 'primaries', Jespersen (1927: 1) means constructions functioning as subjects, objects, and objects of prepositions.
4. Subject-auxiliary inversion is referred to as a test for the subjecthood of PP's by Stowell (1981: 268) and Safir (1983: 731). Raising constructions are referred to by Williams (1984: 662), Safir (1983: 732), and Chametzky (1985: 28). The coordination test is not mentioned in these works.
5. Stowell (1981: 269, 273-276) analyzes such sentences as containing an empty subject with the trace of the PP preposed to topic position.
6. Words like *deszcz* 'rain', *śnieg* 'snow', *mżawka* 'drizzle', etc. are masculine and feminine, so they could not be the antecedents of the neuter pronouns *to* or *ono*. (7.27a) and (7.27b) with *to* are acceptable when *to* is understood as an emphatic particle. The meaning of these sentences then is something like 'Didn't it rain!' and 'Wasn't it cheerful there!', respectively.
7. I omit the PP's from these examples to avoid constructing examples in which they would be construed as modifying the subject NP's
8. Certain constituents which are analyzed as subjects within GB are also included in this description of objects. These are subjects of infinitival clauses following 'raising-to-object' verbs like *believe*, e.g. *the milk* in *We believe this milk to be contaminated*.
9. On p. 662, Williams seems briefly to refer to non-NP objects but the wording is too brief and imprecise for any interpretation.
10. Emonds (1976: 15-16), in his contribution to the formulation of X-bar Theory, imposes restrictions on the base component to exclude rules of the form VP ---> PP, AP ---> S, S ---> PP, etc.

11. The points summarized here are made by Jackendoff with detailed reference to spatial PP's. I feel justified in describing spatial and temporal PP's jointly here in view of his discussion of temporal PP's on pp. 189-191.
12. As was mentioned in note 6 to Chapter 3 (p. 92), some apparent P-PP structures do not obviously lend themselves to the Path-Place interpretation. The example in (ii) is from Quirk et al. (1985: 658).

- (i) a. They talked *about between the wars*.  
 b. Myślał o po egzaminach.  
 he-thought about after exams  
 'He was thinking about/of after the exams.'
- (ii) The weather has been fine *except in the north*.

The first prepositions in these strings do not seem to have a path meaning.

Another exception to my description is the occurrence of manner PP's in typical NP positions, pointed out to me by Mr. T.F. Hoad.

- (iii) a. *In capital letters* will have the best effect.  
 b. They considered *on foot* to be the cheapest.  
 c. He's travelled on this route in every manner  
 except *on horseback*.

13. Note, however, that among Quirk et al.'s examples of subject PP's in (7.2) above are *In March suits me* and *On Tuesday will be fine*. These subjects contain redundant prepositions of the kind discussed here.

14. Akmajian and Heny (1975: 147) provide a precise formalization of passive, which I have adopted with minor simplifications in (7.82). They do not, however, provide a formalization of raising. (7.83) is based on one of their tree diagrams. Both formulations are adequate for the purpose of this section.

Classical formulations of transformations consist of a 'structural description' (SD) -- a specification of the string of elements involved in a transformation -- and a 'structural change' (SC) -- a statement about the effect of the operation. The 'V' and 'Copula A' in the SD of the raising rule are to provide for raising sentences with, respectively, raising verbs (e.g. *seem, appear*) and raising adjectives (e.g. *certain, obvious*). The 'X' in the SD of this rule stands for 'the rest of the constituent labelled S'.

## CHAPTER 8

### SUBJECT AND OBJECT PP's: A GB ANALYSIS

#### 8.1. Introduction

In this chapter, I shall consider another category-based framework, the GB framework, which, on the face of it, fares no better than classical TG when confronted with raising and passive sentences with PP's as their subjects. Within GB, as presented in Chomsky 1981, raising and passive constructions involve a Case Filter, which specifically refers to lexical NP's as requiring Case. The effect is that if a lexical NP is in a position to which Case is not assigned, it must be moved to a position to which Case is assigned. Assuming that the mechanisms at work in sentences with PP's in typical NP positions are identical to those in sentences with NP's, PP's should also require Case. It is possible to incorporate this idea into the framework, given a particular view of Case and Case assignment, and a revised Case Filter.

The present chapter is devoted to an elaboration of this idea. The discussion is organized as follows. In Section 8.2, I introduce some further general details of GB. In Section 8.3, I present a critical discussion of Stowell's (1981) analysis of subject PP's involving the Case Resistance Principle. In Section 8.4, I develop my own analysis of the data. Section 8.5 summarizes the discussion in this and the

preceding chapter.

## 8.2. Raising and passive constructions in GB

Raising and passive constructions are analyzed in GB in terms of the transformational rule 'move  $\alpha$ ' (cf. Chapter 1, p. 20 above) and the well-formedness conditions imposed by Case Theory and Theta Theory.<sup>1</sup> (In the present context, the latter is of limited relevance and I shall refer to it only in passing.) In addition to movement, passive constructions also involve a lexical rule.

The components of Case Theory are Case, Case marking conventions, and the Case Filter (CF). Case marking and the CF apply at S-structure. Typically, in raising and passive constructions, move  $\alpha$  moves a lexical NP from a position to which Case is not assigned to a position to which it is assigned.

Case is normally assigned under specific structural conditions. It is called 'structural' Case (as opposed to 'inherent' Case, see p. 243 below). The key notion in structural Case assignment is 'government' (cf. Chapter 1, p. 21 above). To recall, verbs and prepositions govern their objects, and INFL governs the subject within the same clause. For an NP to be assigned Case, it must be governed by an  $X^0$  which has the capacity to assign Case.

A subject NP is assigned nominative Case if a complex of agreement features (AGR) is associated with INFL, i.e. if the NP is subject in a finite clause. An NP is assigned objective Case if it is governed by a verb that subcategorizes for an NP or by a preposition (or by the prepositional complementizer *for* in English). The Case marking conventions, directly applicable to English, are as follows (cf. Chomsky 1981: 170, 292):<sup>2</sup>

(8.1) Case marking conventions

- a.  $\bar{N}$  is [+ NOM] if governed by INFL[+ AGR]  
 b.  $\bar{N}$  is [+ OBJ] if governed by V[ $\bar{N}$ ] or by P

Case assignment prevents lexical NP's from violating the Case Filter, which Chomsky (p. 49) formulates as in (8.2).

(8.2) Case Filter (CF)

- \* NP if NP has phonetic content and has no Case

This marks as ungrammatical structures containing lexical NP's with which no Case is associated.

(8.3) and (8.4) illustrate typical raising and passive sentences, their D-structures, and derivations.

(8.3) a. *This arrangement seems to be convenient.*

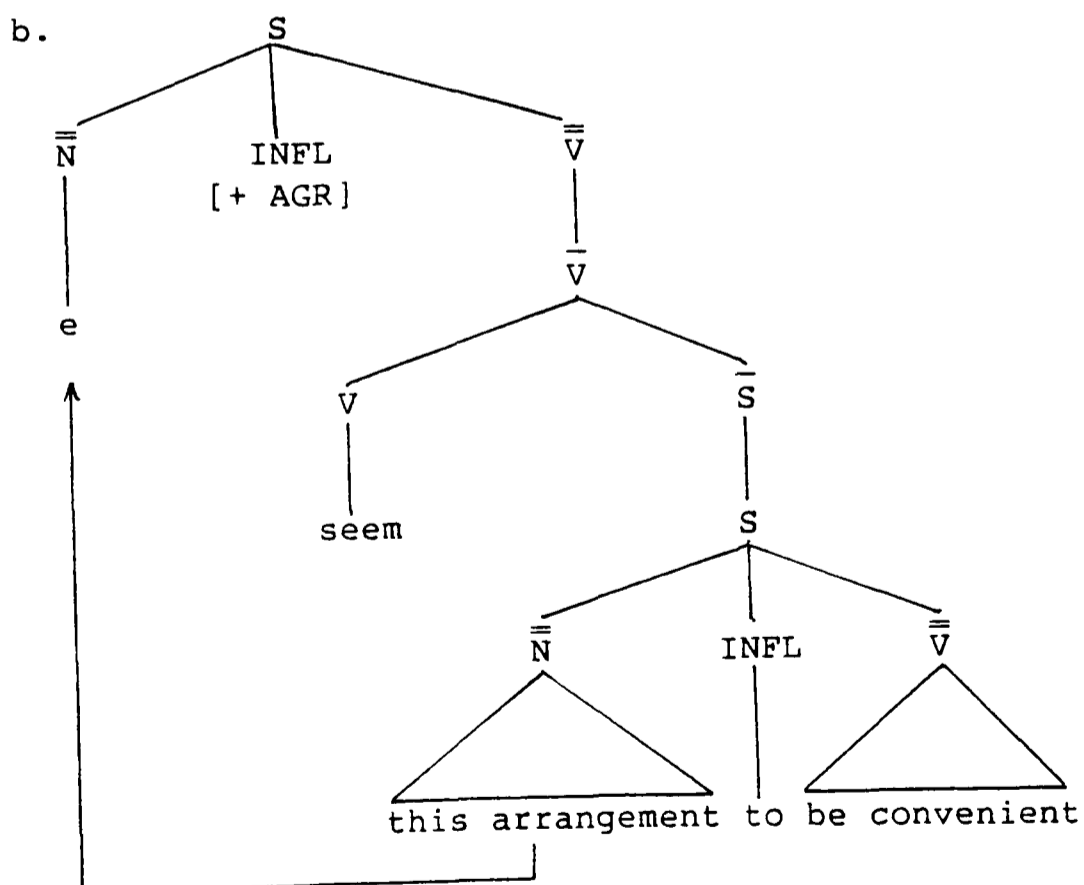

(8.4) a. *The shed was examined by the police.*

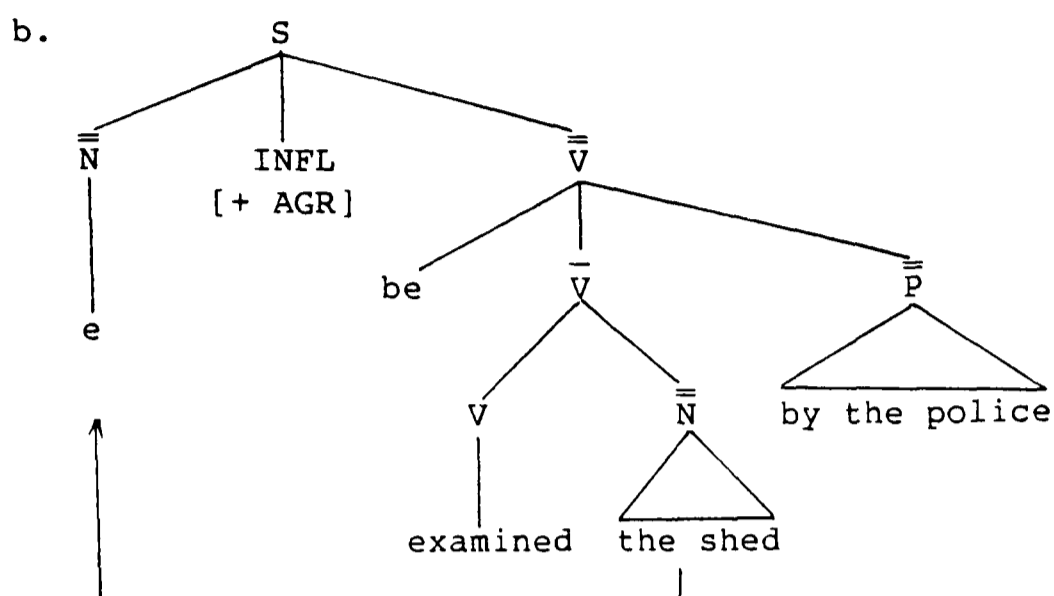

As (8.3b) shows, the surface subject of the raising sentence, *this arrangement*, originates as the subject of the clausal complement of *seem*. After ' $\bar{S}$ -deletion' (cf. Chomsky 1981: 66), this verb will govern the NP but it will not assign Case to it since it does not subcategorize for an NP. The NP *this arrangement* will not be assigned Case by the governing INFL either since INFL is not [+AGR]. Thus, if there is no movement, the resulting (8.5) is ungrammatical.

(8.5) \* *It seems this arrangement to be convenient.*

Once moved, the NP will receive Case from the governing INFL[+AGR] in the higher clause.

As (8.4b) shows, the surface subject of the passive sentence, *the shed*, originates as the complement of the 'passive participle' *examined*. Passive participles have no capacity to assign Case either. Hence, (8.6) is ungrammatical.

(8.6) \* *It was examined the shed by the police.*

This NP too must be moved to the empty subject position, where it will receive Case from the governing INFL[+AGR]. In a sense, then, the

movement of the NP's in both these constructions is obligatory, triggered by the requirement that lexical NP's have Case.

Exactly the same pattern occurs in examples with PP's. As (8.7a) and (8.8a) below illustrate, a PP cannot appear in a position to which Case is not assigned but, as illustrated in (8.7b) and (8.8b), it can appear in a position to which Case is assigned.

(8.7) a. \* It seemed *after dinner* to be convenient.

b. *After dinner* seemed to be convenient. (= (7.82a))

(8.8) a. \* It was examined *behind the shed* by the police.

b. *Behind the shed* was examined by the police. (= (7.82b))

The most obvious interpretation of this pattern is that the movement of the PP's is obligatory because, like the NP's in the earlier examples, they require Case. I shall develop this idea in Section 8.4.

For the remainder of the present section, I turn to Theta Theory and then to the lexical passive rule.

Theta theory requires complements and most subjects to bear a unique 'theta' (or semantic) role. Only one theta role can be associated with a given constituent (Chomsky 1981: 36). Objects and objects of prepositions receive their theta roles from the subcategorizing verbs and prepositions, respectively. Predicates assign a theta role to their subjects but VP's headed by raising verbs and passive participles do not have this property. In raising and passive sentences, subjects receive their theta roles by inheritance of the theta role assigned to their traces. This accounts for the fact that the subject of a raising sentence is interpreted as subject of the infinitival complement, and the fact that the subject of a passive sentence has the same interpretation as the object of the corresponding active sentence.

Following a brief suggestion in Chomsky (1981: 55), and Marantz's (1982: 135-137) arguments, I regard 'verbal' participles as members of the category [- N, + V] (i.e. V), formed by a lexical rule from active verbs.<sup>3</sup> This changes the morphology of the verb and removes its ability to assign Case and to assign a theta role to its subject via the VP (Chomsky 1981: 124). It follows that passive participles are formed from those verbs that can assign Case to their objects. The lexical rule does not change the subcategorization feature of the verb.

Other things being equal, raising and passive sentences in Polish should also involve movement, subject to the principles of Case and Theta Theories. This assumption requires some justification in view of the claim made by Zabrocki (1981: 118-126, 138, 141-146) that in Polish, these constructions are base-generated, and that the active-passive relation is captured by a lexical rule which alters the subcategorization feature of the verb.

Such an account is possible, however, only if the object in the active sentence is a subcategorized complement of the verb. Given GB assumptions about the relation between theta role assignment and subcategorization, a purely lexical account is impossible for passives of verbs taking 'small clauses' (cf. Chapter 4, p. 108). Such passives are not discussed by Zabrocki.<sup>4</sup> Some relevant examples are given in (8.9).

- (8.9) a. *Ta informacja była uważana za fałszywą.*  
           this information(NOM) was regarded as false
- b. *Uważali tę informację za fałszywą.*  
           they-regarded this information(ACC) as false

The syntactic subject in the passive sentence in (8.9a) is understood as

the subject of the predicate *za fałszywą* 'as false', as is the object in the active sentence in (8.9b). In both sentences, then, the NP receives its theta role from the PP. If the NP in (8.9b) were a subcategorized complement of the verb, the verb would assign a theta role to it. Therefore, the NP cannot be a complement of the verb but must be subject of a small clause:<sup>5</sup>

(8.10) *Uważali* [<sub>sc</sub> [ $\bar{N}$  *tę* *informację*] [ $\bar{P}$  *za fałszywą*]].

Since the NP is not a complement of the verb here, a lexical rule alone cannot provide for a passive sentence and it must be supplemented by movement. The S-structure of (8.9a) is as in (8.11).

(8.11) [ $\bar{N}$  *Ta informacja*] *była uważana* [<sub>sc</sub> [ $\bar{N}$  *t*][ $\bar{P}$  *za fałszywą*]].

As required, the NP here will receive its theta role from the predicate PP, indirectly, via the trace. If passive sentences like (8.9a) involve movement, it can reasonably be assumed that other (verbal) passives in Polish do also.

Since movement is certainly involved in the passive construction in (8.9a), it must also be involved in raising sentences like (8.12) because -- to put it in classical TG terms -- passivization 'feeds' raising.

(8.12) *Ta informacja wydawała się być uważana za fałszywą.*

this information seemed PRT be regarded as false

Here, the raising verb is followed by an infinitival passive, *być uważana*, in a sentence related to (8.9a). Since its subject is interpreted as the subject of the PP, the S-structure of (8.12) is of the following form:

(8.13) [ $\bar{N}$  Ta informacja] wydawała się [ $\bar{S}$  [ $\bar{N}$  t] być uważana  
 [ $\bar{sc}$  [ $\bar{N}$  t][ $\bar{p}$  za fałszywą]]].

If raising sentences like (8.13) involve movement, then simpler raising constructions like (8.9a) will involve movement as well. Needless to say, a movement analysis will be assumed for the analogous constructions in (8.14) with PP's instead of NP's.

- (8.14) a. *Pod schodami* jest uważane za dobrą kryjówkę.  
 under stairs is regarded as good hiding-place
- b. *Pod schodami* wydaje się być uważane za dobrą  
 under stairs seems PRT be regarded as good  
 kryjówkę.  
 hiding-place

### 8.3. Subject PP's and the CRP

In earlier chapters, I referred to Stowell's (1981: 146) Case Resistance Principle in connection with PP and  $\bar{S}$  objects of prepositions (cf. Chapter 3, p. 86 above). I pointed out that it incorrectly rules out these constructions in excluding [-N] categories from Case marked positions. The CRP predicts that PP's will not occur in subject and object positions, with which nominative and objective Cases are associated.

Stowell fails to notice acceptable examples with object PP's and a set of examples with subject PP's, and concentrates on providing an account of sentences with PP subjects in copular constructions such as in (8.15).<sup>6</sup>

(8.15) a. *Under the bed* is a nice place for the cat to sleep.  
 (= S's (27a), p. 268)

b. *Under the stars* is a nice place to sleep.  
 (= S's (i), p. 225 n. 43)

According to Stowell, PP's in such constructions do not really violate the CRP because of 'a special property of copular constructions which permits nominative case to be absorbed or deflected away from the subject position' (p. 268, also p. 225 n. 43). This means that in copular constructions, (nominative) Case marking is optional.

This account presupposes the mechanism illustrated in (8.16), which is not very satisfactory.  $\overline{\overline{V}}$  stands for a super-category subsuming NP's and PP's (cf. Table 1.1, p. 13 above).

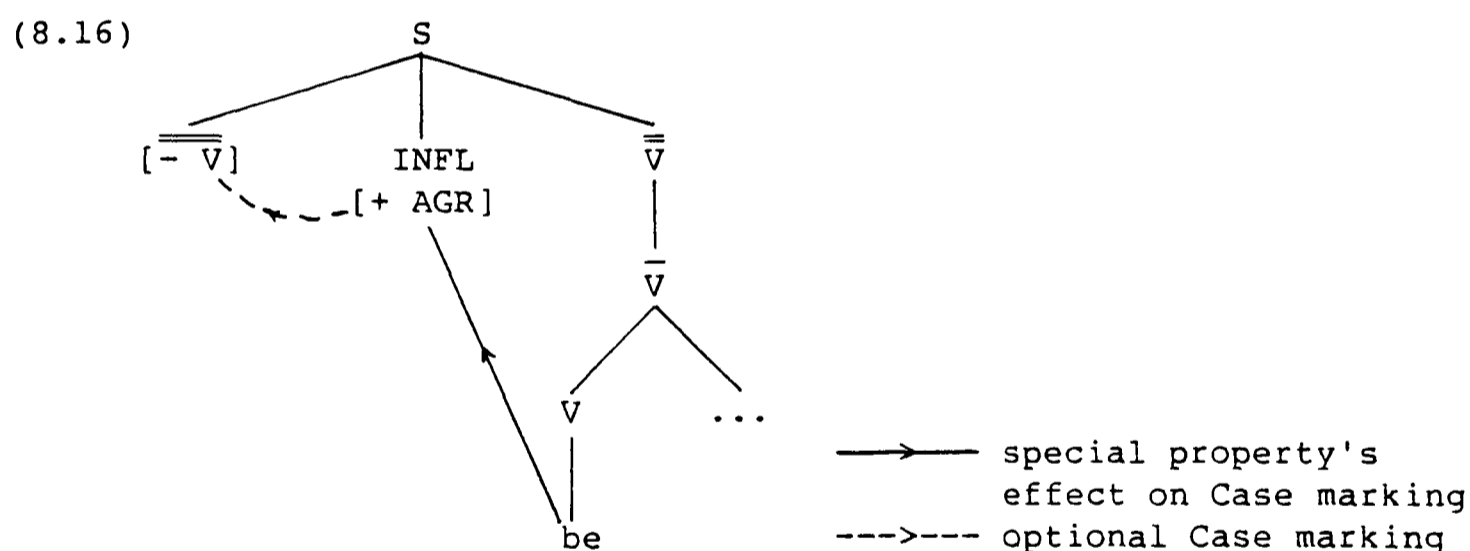

As this diagram illustrates, the ability of a Case-assigning element (in this case, INFL[+AGR]) to assign Case to a governed constituent ( $\overline{\overline{V}}$ ) is -- according to Stowell -- influenced by some lexical property of the head of its sister maximal projection (a copular verb, e.g. *be*). Accepting this mechanism, one would expect to encounter a similar mechanism elsewhere. A comparable relation would occur if, for example, a verb optionally assigned Case to its object if it also took a PP complement with a particular preposition as its head. The configuration

in (8.17) is comparable to (8.16).

(8.17)

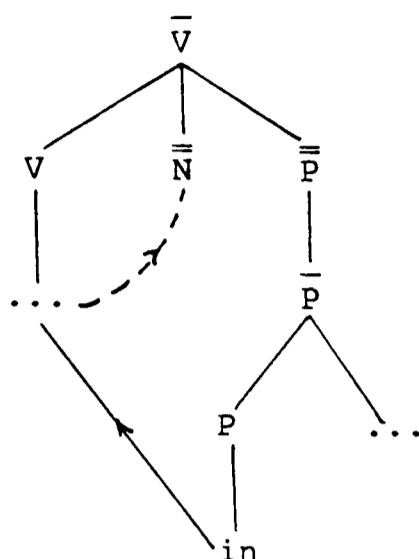

As far as I can see, no construction can be associated with this kind of relation.

A more serious problem with the CRP is that it prohibits PP's from bearing Case. As already noted (p. 230), however, there is evidence from raising and passive constructions (not referred to by Stowell) that PP's sometimes not only allow Case but actually require it. It appears, then, that there is no place for the CRP in an account of the distribution of PP's.

#### 8.4. The analysis

Once we recognize that PP's require Case, we must revise the Case marking conventions in (8.1) and the Case Filter in (8.2) to accommodate this category.

A possible revision of the latter might be something like (8.18),

(8.18) \*  $[-\bar{V}]$  if  $[-\bar{V}]$  has phonetic content and has no Case.

where  $[-\bar{V}]$ , as in (8.16) above, subsumes NP's and PP's. This Case Filter would imply, however, that not only all lexical NP's but also all lexical PP's must bear Case. Its effect would be similar to the effect of the inclusion of PP as an alternative to NP in the formulations of

the classical TG raising and passive transformations in (7.80) and (7.81) (cf. pp. 221-222 above). For example, the Case Filter would rule out sentences like those in (8.19) since the PP's there are governed, respectively, by a non-Case-assigning verb and by a noun.

- (8.19) a. They looked *for a solution*. (= (7.84b))  
 b. She has a dog *with big ears*.

Since there is no reason for such PP's to be Case marked, this Case Filter must be revised further.

First, however, we need to find a way of distinguishing between PP's (and possibly other categories, see Chapter 9, Section 9.1 below) that do and do not require Case. We shall also need a way of distinguishing between verbs that can and verbs that cannot assign Case.

To make the first of these distinctions, I shall draw on the idea in Gazdar *et al.* (1985: 23) that 'case' is represented as a feature, CASE, which takes a case-name (e.g. NOM, OBJ, INST, etc.) as its value. This approach contrasts with the more familiar representation of 'case', current in the GB formalism, as a set of binary features  $\pm$  NOM,  $\pm$  OBJ, etc.<sup>7</sup>

Within the proposed approach, it is quite easy to incorporate the idea that some categories are not marked for Case in D-structure but require Case. We can do this by adding ZERO to the stock of the possible values of the feature CASE. The [CASE, ZERO] feature specification will mark just those constituents that require Case, and a structure containing a constituent so marked will be rejected by the Case Filter in (8.20), a further revised version of (8.18).<sup>8</sup>

(8.20) Revised Case Filter I (RCF)

- \*  $\overline{[-V]}$  if  $\overline{[-V]}$  has phonetic content  
 [CASE, ZERO] (cf. (8.18))

From now on, I shall refer to the original Case Filter in (8.2) as the CF, and its revised formulation in (8.20) as the RCF.

The PP in, e.g. *They looked for a solution* in (8.19a) above will not have [CASE, ZERO] associated with it and will not be subject to the RCF. The assignment of Case, usually formulated as an addition of a positively specified binary feature to an appropriate NP (cf. the Case marking conventions in (8.1) above) will now involve a change of the value of CASE from ZERO to one of the other values. I present appropriately revised Case marking conventions in (8.23) below.

Let us now briefly compare the two approaches to Case. Assuming the 'binary feature' approach, one would need an additional binary feature, something like  $\pm$  REQUIRE CASE, to identify constituents in the suitable way. However, adopting a feature like this alongside the other binary features related to Case, one would be treating Case requirement and Case assignment as matters more distant than they really are. A system in which Case requirement is the consequence of one of the values of CASE is simpler and more elegant. Such a system also automatically predicts that a category in a given structure has only one Case marking (and hence one case form) since the feature CASE, like any other feature, can only have one value. Within the binary feature approach, a stipulation is necessary to ensure that if one of the set of Case features is specified positively (e.g. as inherent Case), the others must be specified negatively. It turns out, then, that the two approaches are not merely notational variants of one another.

We can now move on to the other distinction mentioned earlier, that between verbs that can and verbs that cannot assign Case. To make this distinction, I adopt a binary feature TRANS ('transitive'). I assume that [+ TRANS] verbs can assign Case, and that [- TRANS] verbs cannot. I

also assume that English prepositions are [+ TRANS] and that Polish prepositions are [- TRANS] (cf. note 2 to this chapter). This means that English prepositions can assign Case but Polish cannot.

As noted earlier (p. 231), in the process of passive participle formation, active verbs lose their capacity to assign Case. This, within the proposed analysis, consists in a change of the value of the feature TRANS from '+' to '-'. As illustrated in (8.22) below, the feature TRANS is part of the feature make-up of a lexical category.

This approach differs from Chomsky's original proposal, according to which Case-assigning verbs are identified through their subcategorization feature (cf. the 'V[      $\bar{N}$ ]' in (8.1b) above). If passive participles are formed from verbs that can assign Case, the two positions make different predictions with respect to which verbs have a passive counterpart. I shall pursue this matter below (pp. 243-244, 265-267).

The feature specification [CASE, ZERO] is part of the feature make-up of subjects and certain complements. It appears in the base in structures of the following form:

(8.21) a.

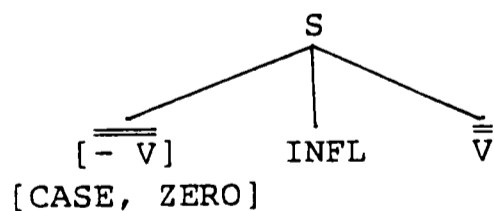

b.

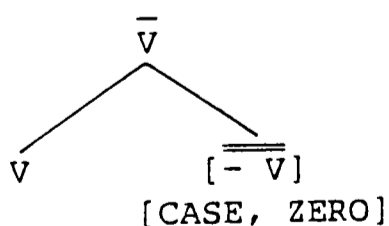

c.

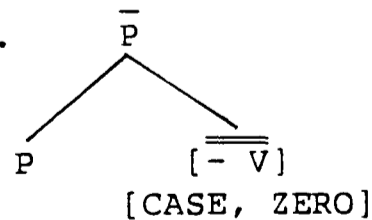

It also appears in the lexical entries of certain verbs (including passives) and of English transitive prepositions as part of the feature make-up of their subcategorized elements, e.g.:

- (8.22) a.  $\left[ \begin{array}{l} \text{examine} \\ [-N, +V][+TRANS] \\ + [ \_ [-V] ] \\ [CASE, ZERO] \end{array} \right]$       b.  $\left[ \begin{array}{l} \text{examined} \\ [-N, +V][-TRANS] \\ + [ \_ [-V] ] \\ [CASE, ZERO] \end{array} \right]$
- c.  $\left[ \begin{array}{l} \text{from} \\ [-N, -V][+TRANS] \\ + [ \_ [-V] ] \\ [CASE, ZERO] \end{array} \right]$

We can now revise the original Case marking conventions:

(8.23) Revised Case marking conventions

- a.  $\left[ \overline{-V} \right] \text{ ---> } \left[ \overline{-V} \right]$  if governed by INFL[+AGR]  
     [CASE, ZERO]      [CASE, NOM]
- b.  $\left[ \overline{-V} \right] \text{ ---> } \left[ \overline{-V} \right]$  if governed by [-N][+TRANS]  
     [CASE, ZERO]      [CASE, OBJ]

According to these conventions, Case marking consists in a change of the value of CASE from ZERO to one of the other values depending, as in the original formulations, on the satisfaction of certain structural conditions: ZERO becomes NOM if the constituent is the subject of a finite clause, and ZERO becomes OBJ if the constituent is governed by a Case-assigning verb or preposition.

A consequence of this analysis is that we have feature specifications like [CASE, NOM] and [CASE, OBJ] associated not only with NP's but also with some PP's. In view of the fact that prepositions do not show morphological variation, this may seem problematic. However, the problem is not very serious. (See Chapter 9, pp. 264-265 below.)

I have now made all the modifications of Case Theory necessary for the derivation of raising and passive constructions in which not only NP's but also PP's participate. Below, I illustrate the derivations of the raising example in (8.7b) and of the passive example in (8.8b), repeated for convenience in (8.24b) and (8.25a),

respectively. In the corresponding diagrams, all the relevant parts of their D-structure are indicated.

(8.24) a. *After dinner* seemed to be convenient.

(= (8.7b))

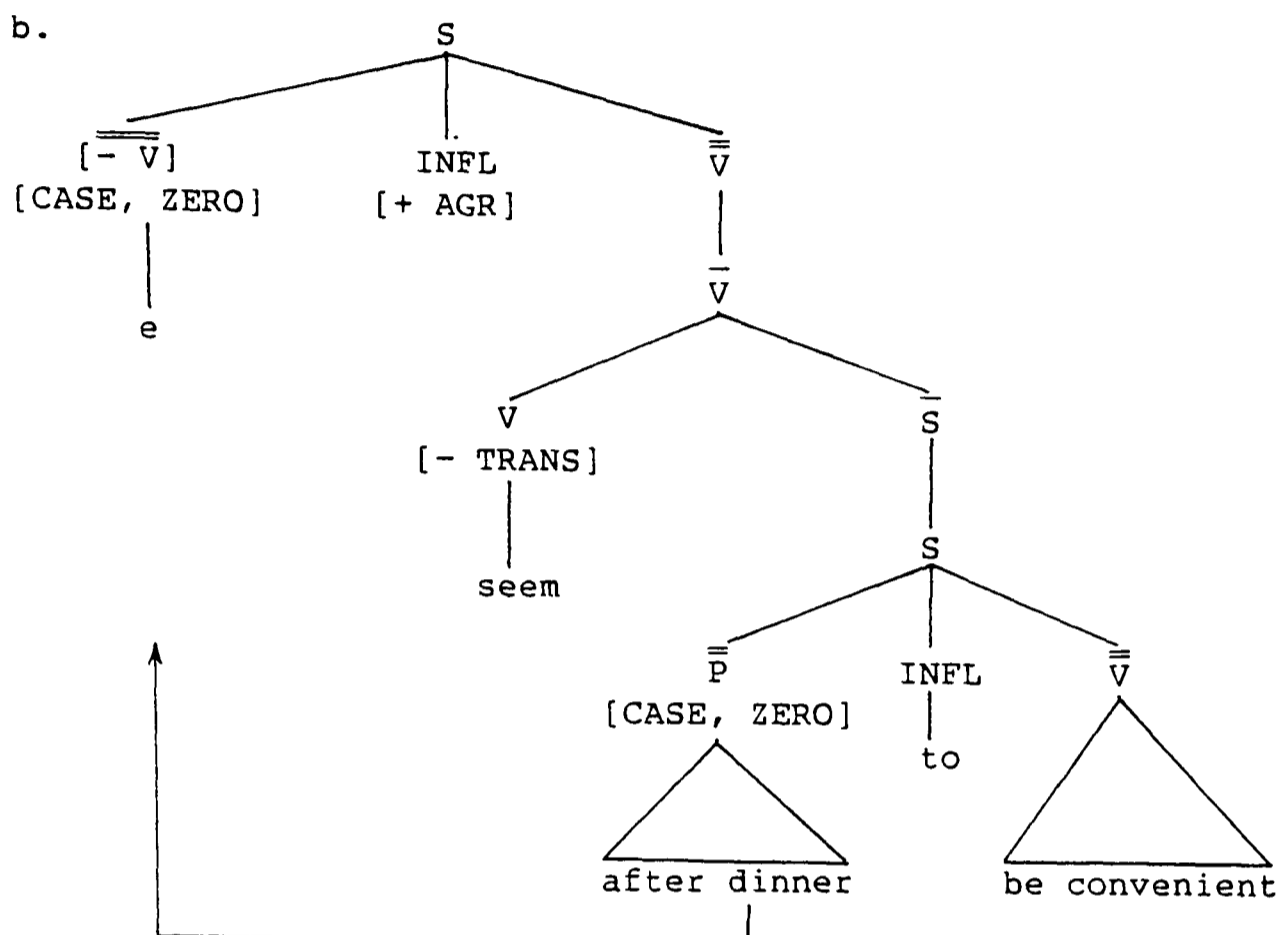

(8.25) a. *Behind the shed* was examined by the police.

(= (8.8b))

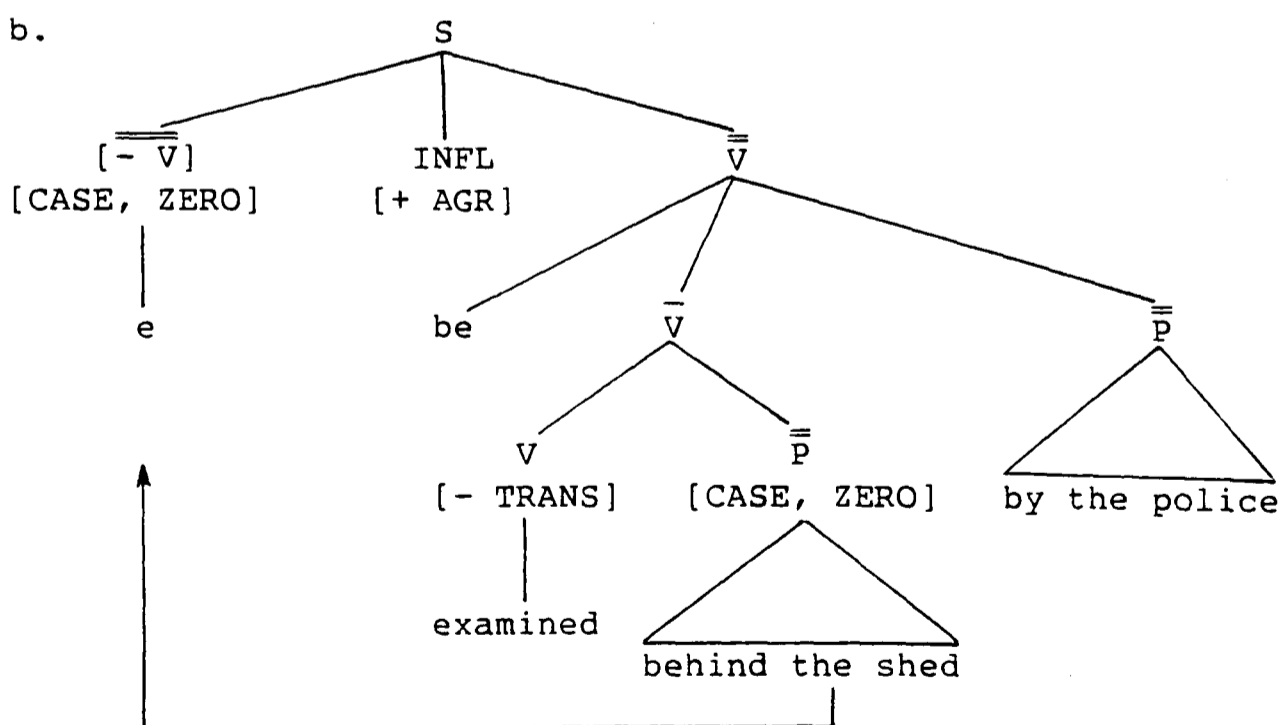

It should be easy to see from these diagrams how the particular elements in the structures interact with each other to result in structures that will satisfy the RCF. In (8.24b), the phrase after *dinner* is generated as a PP subject of the lower, non-finite, clause. This is a position with which the feature specification [CASE, ZERO] but no Case is associated. When the PP is moved to the empty position in the higher clause, it will be governed by INFL[+AGR] and [CASE, ZERO] will become [CASE, NOM] by the Case marking convention in (8.23a).

In (8.25b), the PP *behind the shed* is generated as a [CASE, ZERO] complement of a passive participle. After movement, it will also become [CASE, NOM].

A simple active sentence with a PP as its object will have the following D-structure:

(8.26) a. The police examined *behind the shed*. (= (7.40a))

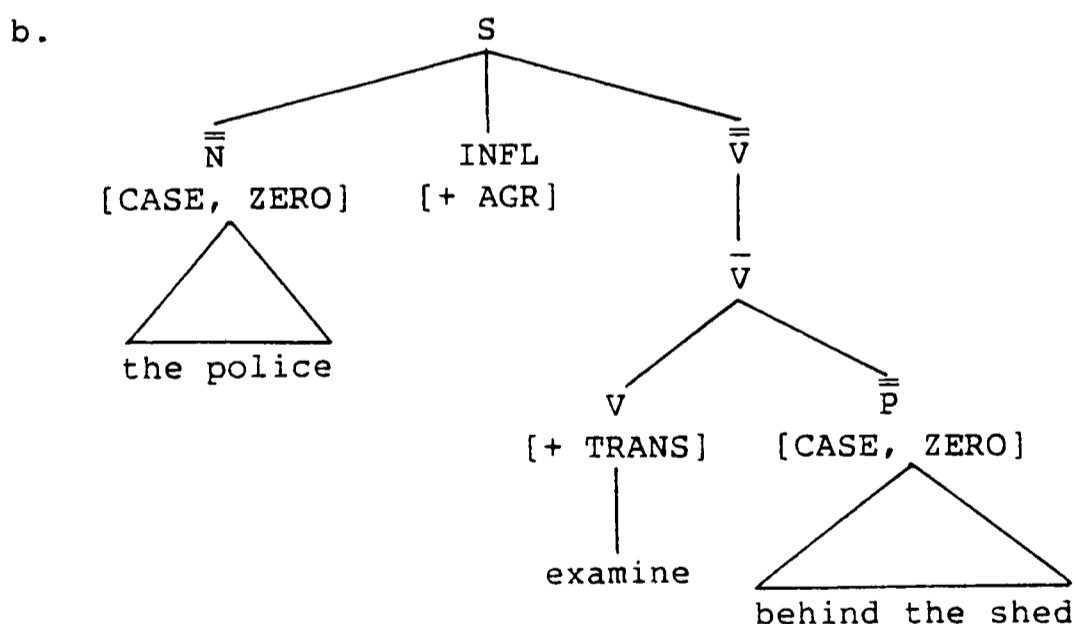

The NP *the police*, governed by INFL[+AGR], will be marked [CASE, NOM]. The PP *behind the shed*, governed by a [+TRANS] verb, will be marked [CASE, OBJ]. Both constituents will thus satisfy the RCF.

Three further examples illustrate the role of the newly-introduced features. Let us first consider the verb *look* in (8.27).

(8.27) They looked for a solution. (= (8.19a))

I mentioned earlier (p. 236) that there is no reason why its complement should require Case. Therefore, the [CASE, ZERO] feature specification will not appear in the subcategorization frame of this verb. Since this verb does not have a passive counterpart, e.g.,

(8.28) \* For a solution was looked. (= (7.85b))

it will be [- TRANS]. *Look* will, then, have the following lexical entry:

(8.29) 
$$\left[ \begin{array}{l} \textit{look} \\ [- N, + V] [- TRANS] \\ + [ \underline{\quad} \overline{P} ] \end{array} \right]$$

Thus, the absence of the feature specification [CASE, ZERO] is as significant as its presence. Its presence or absence differentiates between constituents of the same basic category with respect to their susceptibility to the RCF.

*Look*, of course, occurs in pseudopassive constructions such as (8.30).

(8.30) A solution was looked for.

Here, we have a complex passive participle, *looked for*. I assume with Bresnan (1982a: 55) that this is formed by a complex verb formation rule followed by passive participle formation. The former combines the verb *look* in (8.29) above with the preposition *for* in (8.31).

(8.31) 
$$\left[ \begin{array}{l} \textit{for} \\ [- N, - V] [+ TRANS] \\ + [ \underline{\quad} \overline{N} ] \\ [CASE, ZERO] \end{array} \right]$$

As indicated in the next lexical entry, the complex verb *look for* inherits the preposition's capacity to assign Case and its subcategorization feature:

$$(8.32) \left[ \begin{array}{l} \textit{look for} \\ [- N, + V][+ TRANS] \\ + [ \underline{\quad} \quad \bar{N} \quad ] \\ \quad \quad [CASE, ZERO] \end{array} \right]$$

The other rule, passive participle formation, changes the morphology and removes the verb's capacity to assign Case, giving *looked~~for~~*, which is [- TRANS].

Finally, we consider verbs like *suit* and *fit* in (8.33).

- (8.33) a. The change suited her.  
 b. These dresses fit them.

The form of their NP complements shows that they bear Case. However, as illustrated in (8.34), these verbs do not have passive counterparts.

- (8.34) a. \* She is *suit*ed by the change.  
 b. \* They are *fit*ted by these dresses.

They must, then, like *look*, be [- TRANS].

But if they are [- TRANS], how do the NP's acquire their Case? We can answer this question by exploiting the idea of so-called 'inherent' Case. According to Chomsky (1981: 170), inherent Case is associated with the second NP in double object constructions like *buy the wife a new hat* and is assumed to be assigned in D-structure.

Given our view of Case, inherent Case can be interpreted as the feature CASE with one of the specific values, e.g. OBJ in English, subcategorized for by certain verbs (and Polish prepositions). Thus, the lexical entry for *suit*, for example, is as in (8.35).

$$(8.35) \left[ \begin{array}{l} \textit{suit} \\ [- N, + V][\underline{- TRANS}] \\ + [ \underline{\quad} \quad \underline{N} \quad ] \\ \quad \quad [CASE, OBJ] \end{array} \right]$$

The above discussion highlights further the difference between the 'standard' and the revised way of identifying verbs that can assign Case and hence passivize. As we recall (cf. p. 238 above), according to the former, they are verbs that subcategorize for an NP. As we have just seen, verbs like *suit* and *fit* subcategorize for an NP but they do not passivize. Hence, they cannot assign Case. Given the proposed approach, on the other hand, Case assignment and passive formation are independent of subcategorization. Therefore, the fact that some verbs taking an NP complement do not have passive counterparts does not come as a surprise.<sup>9</sup>

#### 8.5. Conclusion

In this chapter and the preceding one, I have examined sentences with PP's in typical NP positions. I have concentrated on subject and object PP's, and on those aspects of PP objects of prepositions that were not discussed in Chapters 3 and 5. In Chapter 7, I showed why we should regard some PP's as subjects and objects, and why we should regard them (and PP objects of prepositions) as bare PP's. I also identified some semantic and pragmatic properties of those PP's. I then turned to an examination of their theoretical significance. Subject and object PP's in simple active sentences and PP objects of prepositions proved to be easy to accommodate within the classical TG framework. However, raising and passive constructions with subject PP's were problematic for it, but not for Relational Grammar. An examination of these constructions in the light of GB has been the focus of subsequent

discussion.

The analysis proposed here rests on the observation that certain PP's must be moved to a position to which Case is assigned. It follows that, like NP's, they require Case. Within the revised Case Theory, Case is regarded as a non-binary multivalued feature, one of whose values is ZERO. [CASE, ZERO] distinguishes constituents which require Case from those that do not. The Case Filter rules out structures with a constituent which requires Case but has not been assigned Case. As a result, we have a category-neutral analysis of raising and passive.

One more point should be noted here, concerning the Case Resistance Principle. Within the proposed approach to Case, the various counter-examples to the CRP cannot be viewed as merely a special class of exceptions to it. If Case marking involves a change from ZERO to some other value of the CASE feature, Case will not be assigned to any phrase at all, but only to those that are marked [CASE, ZERO], regardless of their lexical category feature specifications. In this situation, there is no possibility of retaining any version of the CRP.

## NOTES TO CHAPTER 8

1. Apart from X-bar Theory, the other sub-theories of GB have no significant bearing on the issues discussed in this chapter and the next.
2. In Chomsky 1981, prepositions are said to assign oblique Case (p. 170) and objective Case (p. 292). The latter point is made with specific reference to English prepositions. Therefore, the Case marking convention in (8.1b) differs from the original on which it is based.

In view of the variety of case forms in Polish, the Case marking conventions in (8.1) would have to be suitably revised for this language. In particular, Case assignment by verbs would have to be stated in terms of verb classes. While most verbs assign the accusative Case to their objects, some assign genitive (e.g. *zabronić fotografowania* 'prohibit photographing(GEN)'), some assign dative (e.g. *zagrozić życiu* 'threaten life(DAT)'), and others assign instrumental (e.g. *kierować zakładem* 'manage an enterprise(INST)'). Case assignment by Polish prepositions should not be a matter of structural Case assignment, however. It is more appropriate to assume, as I did in Chapter 5 (cf. note 2 to Chapter 5, p. 155 above), that prepositions subcategorize for NP's with a specific (inherent) Case. To appreciate why, one must bear in mind that NP objects of English prepositions are regarded as recipients of structural Case because, like objects of verbs, they can appear as subjects in passive constructions, e.g. *This bed has been slept in*. Since such constructions do not occur in Polish (e.g. the Polish counterpart of the above English example, *\*To łóżko było spane w* is unacceptable), there is no motivation for associating structural Case assignment with Polish prepositions.

3. Following Wasow 1977, Chomsky 1981 recognizes a distinction between 'syntactic' and 'lexical' passives (e.g. *A bird was saved* vs *This house is uninhabited*). The passives considered in this chapter are syntactic passives. Chomsky claims (pp. 117, 54-55) that while lexical passive participles are adjectives (i.e. [+N, +V]), syntactic passive participles are members of a 'neutralized' category [+V]. As Marantz (1982: 135-137) shows, nothing is gained by regarding syntactic passive participles as adjective-like. Therefore, I assume that such passive participles are verbs.
4. Zabrocki's discussion is based on Chomsky's ideas in Chomsky 1980, which antedates Chomsky's adoption of the position that a verb assigns a theta role to all its complements. See Chomsky (1981: 32,33, 109-110) for a discussion of equivalent English constructions.
5. I label the small clause constituent 'sc' without indicating its category status, which is unimportant in the present context.

6. Stowell cites the following examples to illustrate the claim that PP's do not appear as subjects in non-copular constructions:

- (i) \* *Under the chair* pleased the cat. (= S's (28a), p. 268)  
 (ii) \* It would be nice for *on the counter-top* to have a nice  
 paint job. (= S's (58a), p. 143)

7. That 'case' should be regarded as a non-binary multivalued feature rather than a binary feature was suggested in Chomsky (1965: 171).

8. A feature specification is an ordered pair [FEATURE, FEATURE VALUE] (Gazdar et al. 1985: 21). I adopt this format for the representation of the multivalued feature CASE. I shall continue to use the format [+ FEATURE]/[- FEATURE] in the representations of binary features.

The formulations of the CF and the Case marking conventions in this section will be slightly modified in the next chapter (pp. 251-152).

9. Cann (1983: 116-119) argues against associating subcategorization for an NP with passive participle formation on the basis of Latin, where some verbs that take an NP complement do not have forms that appear in passive sentences.

## CHAPTER 9

## SOME FURTHER CONSIDERATIONS

9.1. Introduction

In the present chapter, I shall consider some further data, which pose problems for 'standard' Case Theory but which can be accommodated quite naturally within its revised version proposed in the previous chapter, thus lending support to it. In the course of the discussion, I shall refine some of the assumptions and the formalism introduced in the preceding discussion.

The chapter is organized as follows. In Section 9.2, I consider examples in which categories other than NP's appear in typical NP positions. In Section 9.3, I discuss the question of Case marking of NP's in adverbial position. In Section 9.4, I ask why NP's with inherent Case do not appear in positions to which Case is not assigned, and in Section 9.5, I discuss verbs which are not obviously 'transitive', i.e., they do not subcategorize for an NP object, but which, nevertheless, form passive participles.

9.2. Other categories as subjects and objects

The occurrence of PP's in typical NP positions raises the question as to whether or not other categories can appear in these positions also. A good range of examples, suggesting a positive answer to this question can be found in Radford (1981: 210).<sup>1</sup> They are cited in (9.1)

and (9.2), annotated with labelled brackets, which reflect the relevant parts of their S-structures.

- (9.1) a. [ $\bar{p}$  *In Paris*] seems [ $_{\mathcal{S}}$  t to be where they first met].  
 b. [ $\bar{S}$  *Why she is leaving*] seems [ $_{\mathcal{S}}$  t to be an obvious question to ask].  
 c. [ $\bar{A}$  *Rather plump*] seems [ $_{\mathcal{S}}$  t to be how he likes his girlfriends].  
 d. [ $\bar{ADV}$  *A little too casually*] seems [ $_{\mathcal{S}}$  t to have been how he addressed the judge].

- (9.2) a. [ $\bar{p}$  *In Paris*] is thought [ $_{\mathcal{S}}$  t to be where they first met].  
 b. [ $\bar{S}$  *Why she is leaving*] is thought [ $_{\mathcal{S}}$  t to be an obvious question to ask].  
 c. [ $\bar{A}$  *Rather plump*] is thought [ $_{\mathcal{S}}$  t to be how he likes his girlfriends].  
 d. [ $\bar{ADV}$  *A little too casually*] is thought [ $_{\mathcal{S}}$  t to have been how he addressed the judge].

(9.1) contains raising sentences with a PP, an  $\bar{S}$ , an AP, and an ADVP as their subjects. (9.2) contains passive sentences with identical subjects.<sup>2</sup>

If the PP's in these positions are bare PP constituents (cf. Chapter 7, pp. 208-210 above), then the other constituents in these positions should be bare  $\bar{S}$ 's, AP's, and ADVP's. Like the PP's, they have been moved from the positions marked t. Since no Case is associated with these positions and since the phrases under discussion cannot appear there on the surface, e.g.,

(9.3) a. \* It seems [<sub>S</sub> [<sub>S̄</sub> *why she is leaving*] to be an  
obvious question to ask]. (cf. (9.1b))

b. \* It is thought [<sub>S</sub> [<sub>Ā</sub> *rather plump*] to be how  
he likes his girlfriends]. (cf. (9.2c))

they must be regarded as requiring Case, i.e., have [CASE, ZERO] as part of their feature make-up. In their surface position, in (9.1) and (9.2), they will be assigned nominative Case.

More data of this kind, including subject XP's in simple active sentences, can be found in Safir (1983: 731-732), Richardson (1984: 322), Williams (1984: 662), Chametzky (1985: 26), and Quirk et al. (1985: 736):

- (9.4) a. *Angry* } is a terrible way to feel. (= S's (5b))  
          *Unwanted* }
- b. *Angry* } seems a terrible way to feel. (= S's (8b))  
          *Unwanted* }
- c. *That Mary loves Susan* seems to bother Fred. (= R's (5a))
- d. *Triumphantly* is how we sang the anthem. (= R's (5c))
- e. *Relaxed* is what Mary wants to be. (= W's (55a))
- f. *Relaxed* seems to be what Mary wants to be. (= W's (56a))
- g. *Happy* seems like a good way to feel. (= Ch's (1c))
- h. *Slowly* is exactly how he speaks. (Q et al.'s)

In (9.5), we have these categories in positions governed by [+ TRANS] verbs, to which objective Case is assigned.

- (9.5) a. He regards *unwanted* as the most terrible way to feel.  
 b. They believe *triumphantly* to be how to sing the anthem.  
 c. Few people believe *that the world is flat*.

Finally, in (9.6), we have the same set of categories as objects of prepositions. The first example comes from Chapter 4 and the second from Emonds (1976: 14).

- (9.6) a. They wondered about *why Ann didn't come*. (= (4.60b))  
 b. The atmosphere changed from *very depressing* to  
*quite gay*.  
 c. Until *quite recently*, these islands were uninhabited.

It would be interesting to consider what types of AP, ADVP, and  $\bar{S}$  can appear in all these NP positions and what factors affect their acceptability. I leave these questions for further research, noting that from among all these XP's, AP's and ADVP's appear to be the most restricted in their appearance.

While the CF and the original Case marking conventions cannot accommodate the above data, their revised versions can, given a minor modification. All we need to do is to replace each occurrence of  $[-\bar{V}]$  with an even more general category symbol  $\bar{X}$ , as illustrated in (9.7) and (9.8).

(9.7) Revised Case Filter II (RCF)

- \*  $\bar{X}$  if  $\bar{X}$  has phonetic content  
 [CASE, ZERO] (cf. (8.20))

(9.8) Revised Case marking conventions II

- a.  $\bar{X}$  ---->  $\bar{X}$  if governed by INFL[+AGR]  
 [CASE, ZERO] [CASE, NOM]
- b.  $\bar{X}$  ---->  $\bar{X}$  if governed by [-N][+TRANS]  
 [CASE, ZERO] [CASE, OBJ]
- (cf. (8.23))

Of all the non-NP's that can appear as subjects in raising and passive sentences because, within my analysis, they require Case,  $\bar{S}$ 's have received the greatest attention in theoretical work. One position that has been assumed in GB is that they are base-generated topics in sentences with an empty subject (Chomsky 1981: 145 n. 85; Safir 1985: 85-86). Arguments for this position, covering  $\bar{S}$  subjects in simple active sentences, were first advanced in Koster 1978. The example in (9.9) comes from his work (p. 60).<sup>3</sup>

(9.9) a. *That Mary loves Susan* seems to bother Fred. (= K's (35c))

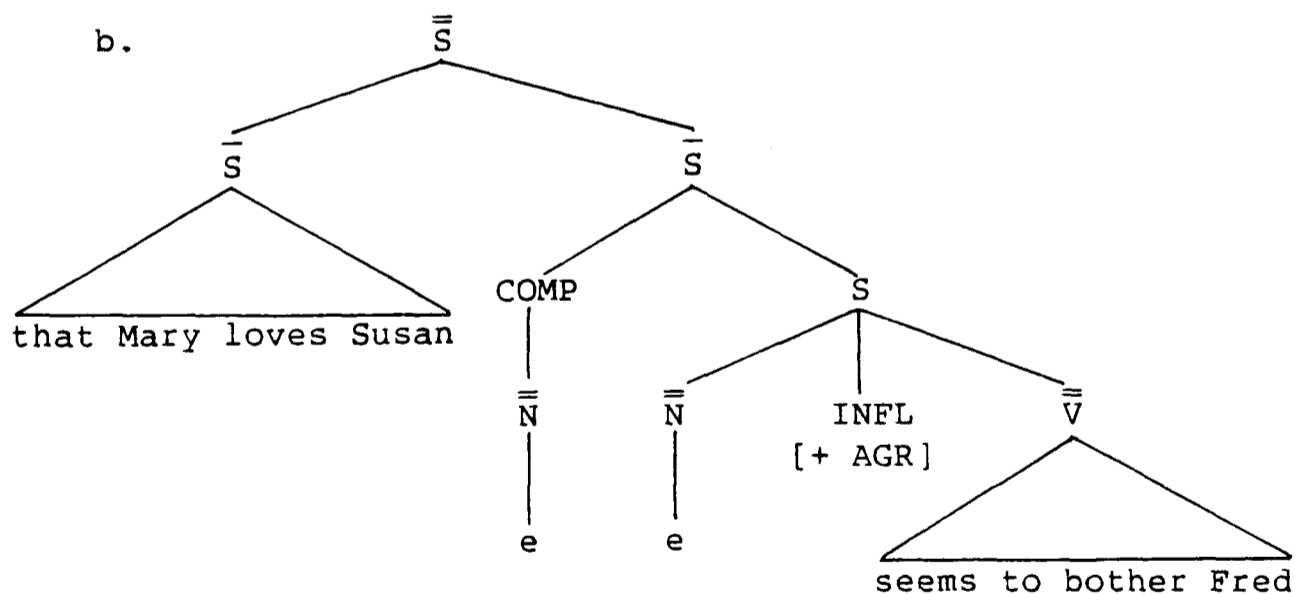

Given this proposal, sentence-initial  $\bar{S}$ 's in raising and passive constructions have not undergone movement and hence they are not regarded as requiring Case. Even if such an analysis of subject clauses were correct, it would not necessarily have to be extended to the other non-NP subjects.

It is doubtful, however, that it is correct. Koster's arguments for the non-existence of subject clauses have been challenged by Delahunty (1983: 382 ff.). Delahunty, among other things, undermines Koster's claims (based on the examples and acceptability judgements cited in (9.10) and (9.11)) that (i) putative subject clauses cannot appear within an embedded clause, and that (ii) they cannot follow the auxiliary verb in questions.

(9.10) a. \* That *for Bill to smoke* bothers the teacher is quite possible. (= K's (2a))

b. \* Although *that the house is empty* may depress you, it pleases me. (= K's (2b))

(9.11) a. \* Did *that John showed up* please you? (= K's (3a))

b. \* What does *that John will come* prove? (= K's (3b))

Delahunty's counter-examples in (9.12) and (9.13) show that  $\bar{S}$ 's can appear in these positions, provided their 'weight' (or 'heaviness') is matched by the 'heaviness' of the predicate.<sup>4</sup>

(9.12) a. I think that *for Bill to remain* would so upset so many people that he and everybody else would be very much more comfortable if he left quietly but immediately. (= D's (7))

b. That *for Bill to smoke* bothers the teacher is not only possible, but quite certain, given what we know of his brand of tobacco, and of the teacher's asthma. (= D's (8))

c. It seems that *that Fred left early* so bothered all of the people who have been waiting for him that they now refuse to do business with him. (= D's (9))

- (9.13) a. To what extent did *that Fred failed to show up* anger those of his devoted fans who had waited by the stage door since dawn of the previous day? (= D's (11))
- b. Why does *that Fred wants to marry her* so upset Mary's mother, father, brothers, sisters and four grandparents that they haven't ceased to harangue her about it since they discovered the proposal? (= D's (12))

Having presented these and some other data, Delahunty then proceeds to argue convincingly that the  $\bar{S}$ 's in question cannot be topics and that they are subjects. As far as I am aware, his challenge has not been taken up by the advocates of Koster's position.

### 9.3. Adverbial NP's

A comparison between the CF and the RCF raises another question: Are there any NP's that do not require Case? According to the CF, a constituent requires Case if and only if it is an NP. According to the RCF, the properties of requiring Case and of being an NP are independent of one another: like PP's, NP's only require Case if they are marked [CASE, ZERO].

In this sub-section, I shall argue that Case need not be associated with adverbial NP's in English and that it cannot be associated with certain adverbial NP's in Polish. The discussion will revolve around the notion 'inherent' Case introduced in the previous chapter (p. 243).

By 'adverbial' NP's, I mean daughters of  $\bar{V}$  as well as NP complements of verbs like *live*, *stay*, and *put*, which are daughters of  $\bar{V}$ . Typically, PP's occur in these positions but ADVP's and  $\bar{S}$ 's do also. The examples of adverbial NP's in (9.14) are from Larson 1985.



position governed by a Case-marking element. [+ F] is, then, a Case-assigning feature specification.

One of the objections to this proposal is that it invokes quite a new mechanism for Case assignment. It would be preferable to assume that the Case marking of adverbial NP's results from a mechanism available already, such as inherent Case. As noted earlier, (pp. 243-244), inherent Case is motivated not only by double object constructions, where it is associated with the second NP, but also by constructions with verbs like *suit* and *fit*, where it must be associated with their NP complements.

An advantage of the revised Case Theory is that the problem addressed by Larson does not arise since, as was indicated at the beginning of this section, not all NP's need have Case. Since NP's in adverbial position in English never show any morphological variation (not even the adverbial pro-forms *there*, *then*, etc., which -- as was noted in Chapter 2 (pp. 48-49) -- Larson argues are nominal) nor do they have any other properties that might be related to Case, we simply need not associate Case with them. Tentatively, then, I suggest that these NP's have no Case.

Rejecting Larson's approach to English data, we still need to appeal to inherent Case in connection with adverbial NP's in Polish, such as those in (9.16)-(9.18).

- (9.16) a. *Wiosną*           byli           w Walii.  
           spring(INST) they-were in Wales  
           'In the spring, they were in Wales.'
- b. *Tej wiosny*       byli           w Walii.  
           that spring(GEN) they-were in Wales

c. *Całą wiosnę* byli w *Walii*.

Whole spring(ACC) they-were in Wales

(9.17) a. *Ojciec* prowadził *dziecko* *tą drogą*.

father led child this way(INST)

'The father led the child this way.'

b. *Ojciec* prowadził *dziecko* *leśną ścieżką*.

father led child forest path(INST)

'The father led the child along a forest path.'

(9.18) *Rozwiąż* to *zadanie* *innym sposobem*.

solve this problem different manner(INST)

'Solve this problem in a different manner.'

The typical case form of such NP's is instrumental although, as illustrated in (9.16), temporal NP's can also be genitive and accusative, depending on the type of modifier.<sup>6</sup> I assume that nouns that can head an adverbial NP will have [CASE, INST], [CASE, GEN], or [CASE, ACC] as part of their feature make-up in the lexicon. (9.19) contains possible lexical entries for the instrumental nouns *wiosną* 'spring', *ścieżką* 'path', and *sposobem* 'manner'.

(9.19) a.  $\left[ \begin{array}{l} \textit{wiosną} \\ [+ N, - V] \\ [CASE, INST] \end{array} \right]$  b.  $\left[ \begin{array}{l} \textit{ścieżką} \\ [+ N, - V] \\ [CASE, INST] \end{array} \right]$  c.  $\left[ \begin{array}{l} \textit{sposobem} \\ [+ N, - V] \\ [CASE, INST] \end{array} \right]$

Unlike [CASE, ZERO], these feature specifications will not appear in the base, in structures introducing adverbial nodes. An adverbial node will only be specified as a 'maximal projection':<sup>7</sup>

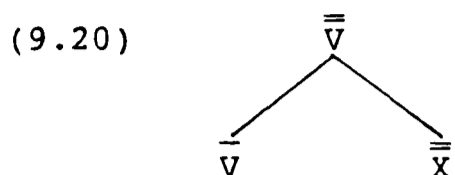

An adverbial node will, however, acquire various features from its daughter through 'inheritance'. For example, given the features of *ścieżką* in (9.19b), the adverbial NP in the example in (9.17b) above will have the following form:

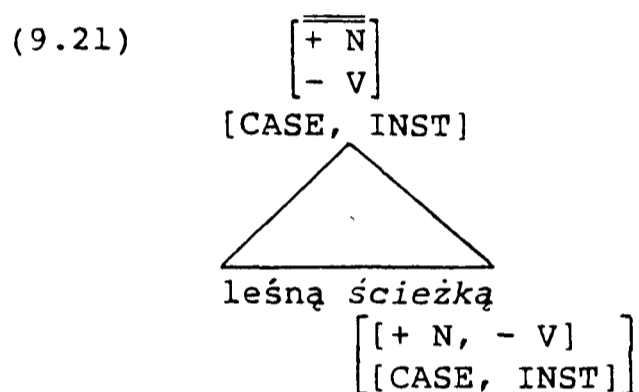

I assume that features are inherited by a mother node from its head in accordance with the Head Feature Convention (HFC) proposed in Sag et al. (1985: 131) and Gazdar et al. (1985: 94-99) in an effort to develop an explicit theory of syntactic features. For the present purpose, it can be formulated as follows:<sup>8</sup>

(9.22) Head Feature Convention (HFC)

Unless otherwise specified, the feature specifications on the mother node must be identical to those on its head or to those shared by its heads

In (9.21), the adverbial NP has a single head, the noun *ścieżką*. (The reference to 'heads' in the HFC is relevant to coordinate structures, to which I turn shortly.) We can see that the only difference between the (lexical) head and its mother is in the bar-level: the former is 'bar-zero' (cf. Chapter 1, p. 15 above), and the latter 'bar-two'. (For the sake of brevity, the intermediate 'bar-one' node is not marked in

this diagram.) This difference is allowed for by the conditional clause of the HFC.<sup>9</sup> Both elements are identical to each other with respect to the other feature specifications: [+ N, - V] and [CASE, INST]. In this situation, we have an adverbial node that is an NP with Case.

(9.23) contains adverbials with more than one head.

- (9.23) a. *Zazwyczaj spacerowali wieczorami lub wczesnym*  
 usually they-walked evenings(INST) or early  
*popołudniem.*  
 afternoon(INST)  
 'Usually, they walked <sup>in the</sup> evenings or early afternoons.'
- b. *Zazwyczaj spacerowali polem lub szosą.*  
 usually they-walked field(INST) or road(INST)  
 'Usually, they walked across the field or along the road.'

These are coordinate constructions with instrumental NP conjuncts. Following Sag et al. (1985: 137) and Gazdar et al. (1985: 170), I assume that in a coordinate structure, each conjunct is a head. In accordance with the HFC, the feature specifications on the coordinate (mother) node must be identical to those shared by its heads (the conjuncts). The distribution of the feature specifications in, e.g., (9.23a), conforms to this requirement. The following represents the structure of the adverbial in this example:<sup>10</sup>

(9.24)

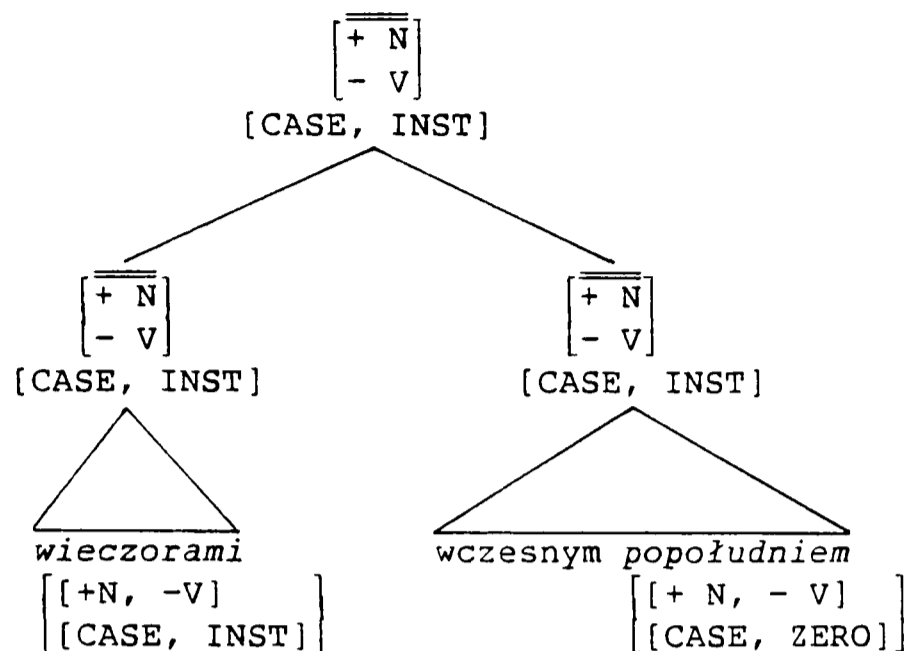

Since the heads here share their feature specifications, the coordinate mother node is identical to them in every respect. Here, too, we have an adverbial NP with Case.

There is one situation, however, where an adverbial NP cannot bear Case. This is when conjoined are NP's in different Case forms, such as in (9.25).

(9.25) a. Przyjadę *tej zimy* albo *wczesną wiosną*.

I'll-come this winter(GEN) or early spring(INST)

'I'll come this winter or early spring.'

b. Deszcz padał *wieczorem* i *całą noc*.

rain fell evening(INST) and whole night(ACC)

'It rained in the evening and the whole night.'

c. Widzieli się *całe Święta* i *tego pamiętnego*

they-saw PRT whole Christmas(ACC) and that memorable

*popołudnia*.

afternoon(GEN)

'They saw each other the whole Christmas and that memorable afternoon.'

Here, the conjuncts share the categorial feature specification [+ N, - V] but not the CASE feature specification. As (9.26) illustrates, the latter will not appear on the mother.

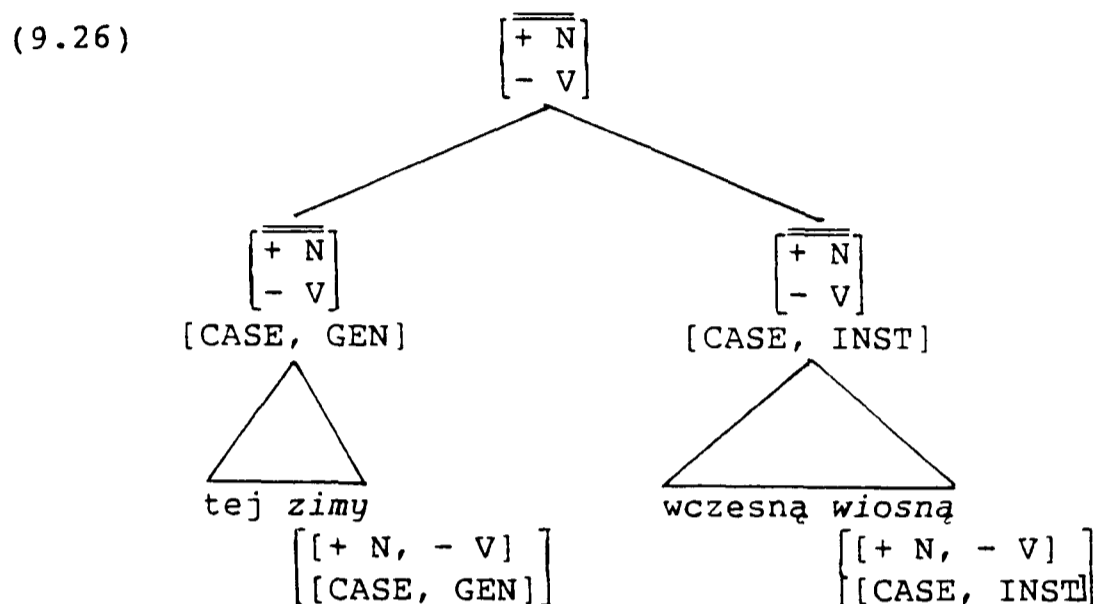

Given (9.26) on the one hand, and (9.21) and (9.24) on the other, it is clear that even in Polish, Case cannot be obligatorily required of all NP's. Since this is required by 'standard' Case Theory but not by its revised version, we have some evidence here against the former and in favour of the latter.<sup>11</sup>

#### 9.4. More on inherent Case

Given that some nouns are inherently Case marked, we must ask why they cannot be inserted into some positions to which Case is not assigned, while they can be inserted into other such positions. The positions in question are subject of the infinitival complement of a raising verb and object of a passive participle. (9.27) and (9.28) contain, respectively, raising and passive examples from English and Polish with inherently Case marked NP's in these positions.

(9.27) a. \* It seems [<sub>S</sub> her to be at school].

- b. \* Wydawało się [s tą drogą być bezpiecznie  
 seem-ed PRT this way(INST) be safely  
 na przemyt cukru].  
 for smuggle sugar  
 '\* It seemed this way to be safe for smuggling sugar.'

(9.28) a. \* It was [ $\bar{v}$  preferred *them*].

- b. \* Zostało [ $\bar{v}$  omówione następnego dnia] pod  
 became discussed next day(GEN) under  
 koniec zebrania.  
 end meeting  
 '(\* ) It was discussed the next day towards the end  
 of the meeting.'

These data pose a problem for the 'standard' approach to Case since, as far as I can see, there is nothing to prevent inherently Case marked nouns from being inserted into any non-Case position with the result that the CF will not rule out structures associated with examples like the above.

Let us assume, for the sake of exposition, that all the positions in which <sup>an</sup> inherently Case marked NP can appear are NP positions, and that the two positions in which they particularly cannot appear are also NP positions. Prior to lexical insertion, they will have the following internal structure:

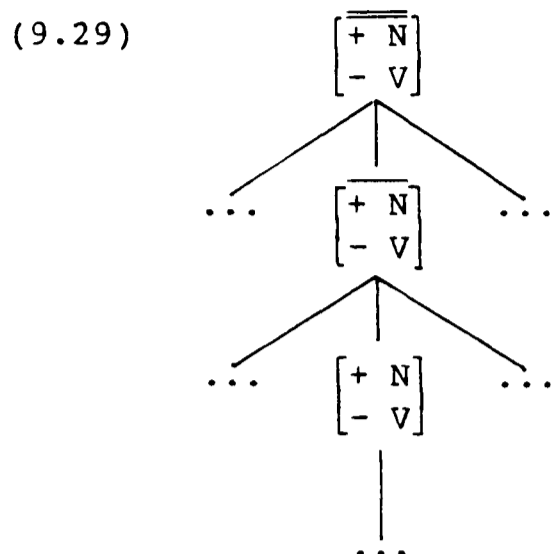

According to Chomsky (1965: 84, 81), a lexical item can be inserted into a preterminal node if it is non-distinct with respect to the features specified on that node, i.e., if the two do not have different values for some feature.

The only features specified on the preterminal node in (9.29) are the categorial features. The nouns *her*, *drogą* 'way', *them*, and *dnia* 'day' in our examples in (9.27) and (9.28) above have these features also. They have other features as well, specifying, e.g., their gender and Case, but since these do not appear on the preterminal node, they do not make the lexical items distinct from this node. Thus, given (9.29), an inherently Case marked noun can be inserted into any non-Case position because its inherent CASE feature specification has no counterpart with a different value in the preterminal node.

We can avoid this consequence within the revised approach to Case. It will be recalled (cf. p. 238 above) that prior to lexical insertion, certain positions are marked [CASE, ZERO]. In (9.30), I provide more explicit versions of the diagrams (8.21a) and (8.21b).

(9.30) a.

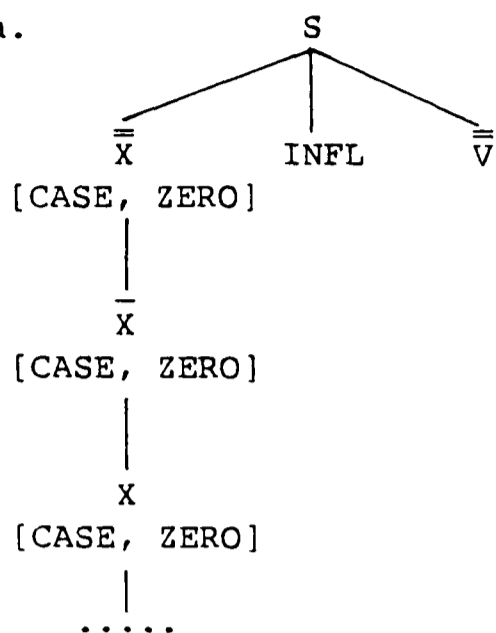

(cf. (8.21a))

b.

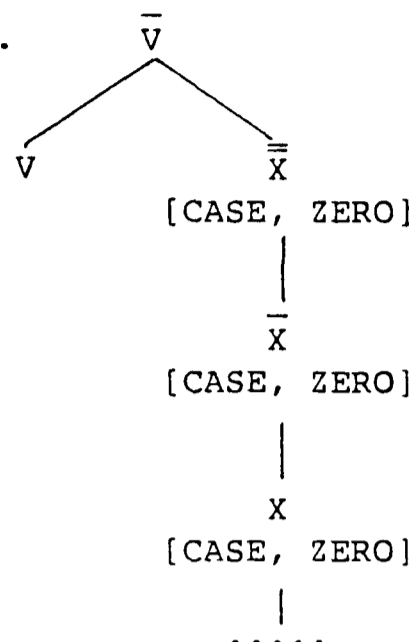

(cf. 8.21b))

Inherently Case marked nouns will not be inserted into these structures because they are distinct from the preterminal nodes X: their values of the feature CASE are different from that on X. Only nouns marked [CASE, ZERO] in the lexicon, as all nouns will have to be, can be inserted into these positions. Inherently Case marked nouns, on the other hand, can be inserted into preterminal nodes with no CASE feature specification (cf. the adverbial node in (9.20) above) or into a preterminal node marked [CASE,  $\alpha$ ],  $\alpha \neq \text{ZERO}$ , as would be the situation with the second node in double object constructions and with some complement positions in VP (cf. *suit* and *fit*).

These considerations bring us to yet another point of detail of the proposed analysis. It follows that in their lexical entries, prepositions (and members of other lexical categories) must have [CASE, ZERO] as part of their feature make-up to allow insertion into one of the [CASE, ZERO] positions. This is an unwelcome consequence since we have no case morphology associated with prepositions.

It can, however, be avoided, given the way the HFC is formulated. As was pointed out before (p. 258), its *unless*-clause allows for the non-identity between a mother and its head. We can stipulate, then, that

the [CASE, ZERO] feature specification on the mother ( $\bar{\bar{X}}$ ) must not appear on its head ( $\bar{X}$ ) unless the head is [+ N, - V], i.e. a noun. This will give us structures like the following:

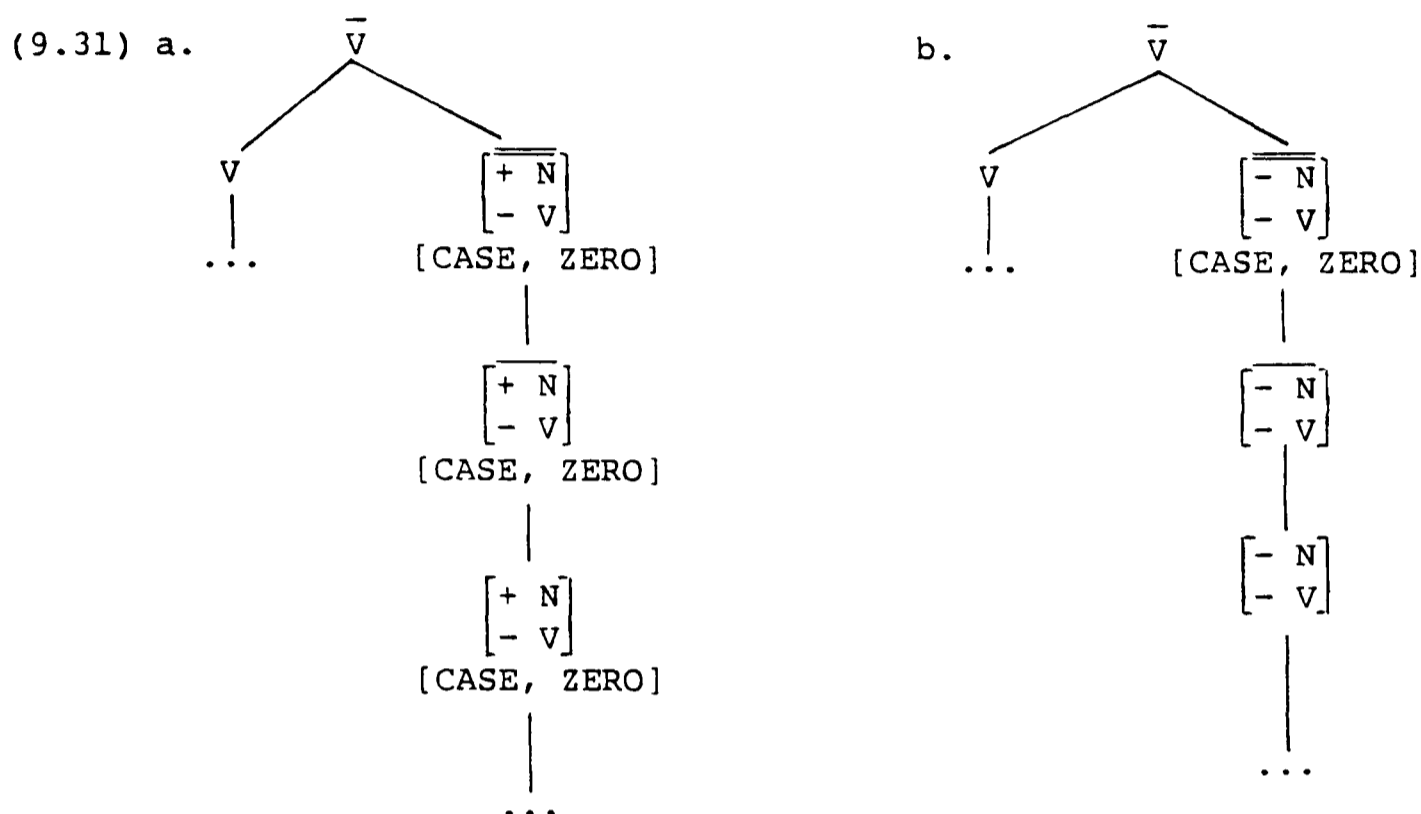

Since the preterminal node [- N, - V] (i.e. P) will not be marked [CASE, ZERO], a lexical item of the category P will not have to be [CASE, ZERO], and hence it will never be [CASE, NOM] or [CASE, OBJ] either. Thus, there will be no implication that case morphology is associated with prepositions without ever being realized.<sup>12</sup>

#### 9.5. Passive without movement

The final issue in this chapter concerns verbs that do not subcategorize for an NP but, nevertheless, have passive participles. This class of verbs, discussed in some detail in Marantz (1982: 138-140; 1984: 133-137), includes *hope*, *feel*, *hold*, *say*, and *reason*.

As illustrated in (9.32), *hope* takes a clausal complement but not an NP complement, and forms a passive participle but does not allow its complement to occur in subject position in a passive construction.

- (9.32) a. Everybody hopes *that spring will come soon*.  
 b. \* Everybody hopes *the arrival of the spring*.  
 c. It is hoped *that spring will come soon*.  
 d. \* *That spring will come soon* is hoped (by everyone).

Referring to an unpublished paper by Williams (1979), Marantz (1984: 135-136) shows that passives like (9.32c) cannot be analyzed as involving obligatory extraposition applied to structures corresponding to (9.32d) and hence that they should be base-generated. Chomsky (1981: 125) adopts this view (attributing it to personal communication from Marantz (p. 150 n. 127)) implying that since -- given his CF --  $\bar{S}$ 's do not need Case, they do not need to be moved to subject position. He does not, however, say why they cannot be moved to this position, i.e., why examples like (9.32d) are generally unacceptable.

Let us first see what is involved in the analysis of the acceptable (9.32a) and (9.32c). In the former, we have the verb *hope*. Since it can form a passive participle, it must be [+ TRANS]. Since its complement does not occur in subject position in passives, the  $\bar{S}$  evidently does not require Case. Therefore, it will not bear the feature specification [CASE, ZERO]. It will not be [CASE, OBJ] either, as there is no reason to invoke inherent Case here. *Hope* will, then, have the following lexical entry:

$$(9.33) \left[ \begin{array}{l} \text{hope} \\ [- N, + V][+ TRANS] \\ + [ \_ \bar{S} ] \end{array} \right]$$

In (9.32c), we have the passive participle of this verb, which is [- TRANS], and which also subcategorizes for a bare  $\bar{S}$  complement. This passive participle appears in the following D-structure underlying the

passive sentence:

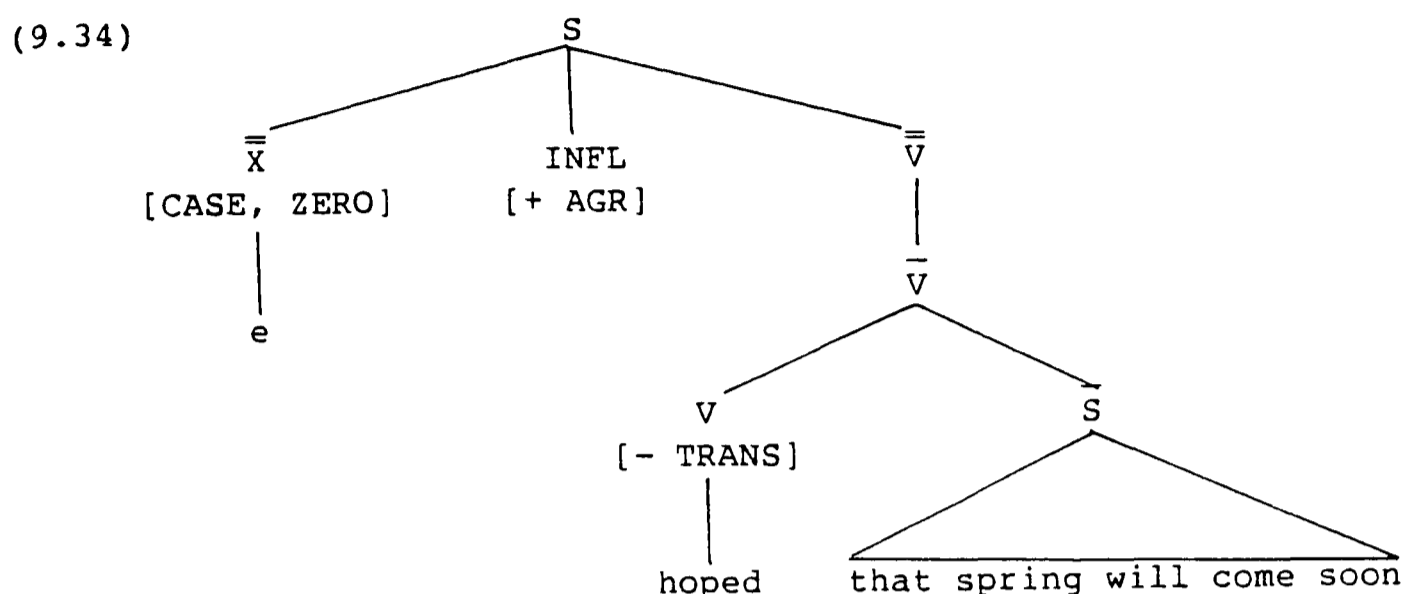

This underlies the acceptable passive in (9.32c), in which a dummy pronoun *it* has been inserted into the empty subject position.

Given this structure, we can account for the unacceptability of (9.32d), which might be derived by move  $\alpha$  moving the clause to the empty subject position. As suggested in Borsley (forthcoming, n. 5), this movement can be prevented by a requirement that the moved constituent must have all the feature specifications of the position to which it is moved. Since the  $\bar{S}$  in (9.34) above does not have the feature specification [CASE, ZERO], it cannot be moved to the  $\bar{X}$ [CASE, ZERO] position.<sup>13</sup> It should be noted that this kind of requirement is not unprecedented -- it is a close relative of Emonds' (1976: 5-6, 68-70) Structure Preserving Constraint. The fact that within the proposed approach to Case we can rule out movement of the complement of the verb in passives like (9.32d) lends further support to this approach.

Verbs like *hope* constitute another class of verbs that are incompatible with Chomsky's notion embodied in the Case marking convention in (8.1b) above, that objective Case is assigned by verbs that subcategorize for an NP (cf. p. 238 above) and hence that only those verbs form passive participles. Although by virtue of discussing

constructions like (9.32c), Chomsky recognizes that verbs that do not take an NP complement can passivize, he does not say this explicitly, and he ignores such verbs when he introduces the Case marking conventions (1981: 170).

#### 9.6. Conclusion

In this chapter, I examined four types of construction in English and Polish within the approach to Case proposed in the previous chapter to accommodate sentences with PP's in subject and object position. It turns out that sentences with other non-NP subjects and objects, and adverbial NP's do not pose any problems for the Revised Case Filter and that within the proposed approach, it is possible to account for the non-occurrence of inherently Case marked NP's in positions to which Case is not assigned. Within the approach to Case developed here, a verb's capacity to assign Case and to form a passive participle are independent of its subcategorization properties. In view of verbs like *suit* and *fit*, which subcategorize for an NP but do not passivize, and verbs like *hope*, which do not subcategorize for an NP but passivize, the proposed approach makes a more adequate prediction than the 'standard' GB approach as to what verbs will and will not passivize.

## NOTES TO CHAPTER 9

1. These examples appear in an exercise where it is suggested that they are problematic for the Extended Standard Theory account of raising and passive constructions in terms of NP-movement -- a category-specific rule.
2. It might be suggested that the subjects in these sentences are 'quotations' and hence irrelevant to the discussion. Note, however, that if they were quotations, in the *why*-clauses in (9.1b) and (9.2b), the subject *she* should follow the verb, as it would in the 'quoted' question, e.g. *Why is she leaving?* vs *\*Why she is leaving?*  
 It might also be suggested that in (9.1a), (9.1c), and (9.1d), and (9.2a), (9.2c), and (9.2d) the XP's are preposed modifiers. Such constructions ('specificational pseudoclefts') are discussed by Williams 1983b, who argues that the initial phrases there are indeed subjects.
3. For Koster, the 'topic' node is a daughter of E ('expression'), which he equates (p. 58 fn. 12) with Chomsky's (1977: 91)  $\bar{S}$ . In my diagram, I use the latter symbol. Stowell's (1981) analysis of subject clauses also relies on Koster's arguments.
4. Further counter-examples can be found in Safir (1985: 323 n. 23) and in Gazdar et al. (1982: 613). The question marks in (i) and (ii) are Safir's.
 

|   |                      |
|---|----------------------|
| (i) ? John knows that to be a fool would embarrass Mary.  |                      |
|   | (= S's (ii))         |
| (ii) ? Is to be careful impossible?                       | (= S's (i))          |
| (iii) Does that she is here surprise you?                 | (= G et al.'s (51c)) |
| (iv) Will whether she arrives determine whether you stay? | (= G et al.'s (51d)) |
5. See Larson (1985: 596) and Quirk et al. (1985: 515, 526-528, 557) for more examples of adverbial NP's.
6. The NP is accusative when it contains the modifier *cały* 'whole' and genitive with some other modifiers, e.g. *ten* 'this', *następny* 'next', and *pół* 'half'. Polish grammars do not provide any insightful descriptions of adverbial NP's. Jodłowski (1976: 96) regards them as 'preposition-less forms of dependent cases' (*bezprzyimkowe formy przypadków zależnych*) and Saloni and Świdziński (1985: 129), as 'non-subcategorized forms of synthetic case' (*nieakomodowane formy przypadku syntetycznego*). It seems fair to equate these terms with inherent Case.

7. It must be noted, for the sake of accuracy, that an adverbial node will also have to be marked with one of such feature specifications as [+ TEMPORAL], [+ LOCATION], [+ MANNER], etc. This follows from the analysis of certain conjoined adverbials in Sag et al. (1985: 143), which accounts for the impossibility of coordination of adverbials of different adverbial 'sub-categories' as in, e.g.:

(i) \* Spacerowali całymi dniami i lasem.  
 they-walked whole days[TEMP] and forest[LOC]  
 '\* They walked whole days and in the forest.'

Since this point has no bearing on matters in hand, I shall not discuss it here.

8. I am grateful to Bob Borsley for a clarification of some more complex formulations of the HFC.
9. In the less formalized version of X-bar Theory current in GB, the difference in the bar-level of a head and its mother is the norm, i.e., heads are assumed to have one bar less than the immediately dominating mother. As Pullum (1985: 347) points out, the HFC implies that it is the norm for a mother and its head daughter (or head daughters) to have the same bar-level.
10. For the sake of simplicity, I omit the conjunctions from this diagram and the next.
11. Safir (1985: 77) has proposed that the CF should be revised so as to affect only NP's in argument positions. Although adverbial NP's would be irrelevant to such a revised CF, PP's in typical NP positions would still be problematic.
12. Given (9.31a), we have to accept that morphological Case marking will be implied for all English nouns although only pronouns show morphological variation. It is to ensure the correct distribution of pronouns that [CASE, ZERO] must appear on the preterminal node N and in the lexical entries of nouns.
13. The same restriction can be invoked in the case of unacceptable examples like (i).

(i) \* *That they are working in the garden* seems t.

Here, we have an  $\bar{S}$  complement of a raising verb in subject position. As Stowell (1981: 164) points out, there is no account within GB of the unacceptability of such examples. Given the analysis proposed here, the clausal complement of a raising verb is a bare S and hence, it cannot be moved into a [CASE, ZERO] position.

## CHAPTER 10

### CONCLUDING REMARKS

#### 10.1. Introduction

In the preceding chapters, I have been concerned with various aspects of the syntax of prepositions and prepositional phrases in English and Polish. I have looked in particular at the types of complement that prepositions can take in both languages and at the occurrence of PP's in subject and object positions. In the course of the discussion, I have made comparisons between prepositions and PP's on the one hand, and other lexical and phrasal categories on the other. I have also touched on some semantic characteristics of the constructions discussed. In this final chapter, I shall draw together the conclusions that have emerged and add some further observations.

The chapter is organized as follows. In Section 10.2, I compare English prepositions and PP's with their Polish counterparts. In Section 10.3, I compare these categories with other lexical and phrasal categories. In Section 10.4, I discuss the role of syntactic categories in the distribution of phrases. Finally, in Section 10.5, I note some areas for further research.

#### 10.2. Prepositions and PP's in English and Polish

Given the obvious differences between English and Polish, one might expect that prepositions and PP's in these two languages would have

little in common. Some Polish linguists seem to think that this is the case. However, one important conclusion that has emerged here is that they are broadly similar.

The PP structures that Emonds 1972, 1976 and Jackendoff 1973, 1977 have highlighted in connection with English as revealing the 'intrinsic syntactic interest' (Jackendoff 1973: 345) of prepositions can also be found in Polish. In Chapter 2, I showed that Polish has PP's consisting of an intransitive preposition, and in Chapters 5 and 6, I argued that some PP's in Polish consist of a preposition and a PP complement, and others of a preposition and an  $\bar{S}$  complement.

This confirms Jackendoff's passing remark (cf. Chapter 1, p. 4 above) that even in languages with a mixture of prepositions and cases these two categories should be regarded as quite distinct. Since no case marking is involved in PP's containing an intransitive preposition and no morphological case is associated with PP and  $\bar{S}$  complements of prepositions, case determination cannot be a defining property of prepositions. It follows that prepositions cannot be analyzed as part of a discontinuous case marker. Such a position was advocated by Kuryłowicz 1949 but it has been abandoned in more recent Polish work on Polish syntax (cf. Chapter 1, p. 27).

Polish and English differ with respect to intransitive prepositions. In English, there is a variety of prepositions that can take an NP complement or no complement (e.g. *in*, *before*) whereas in Polish, such prepositions are less common. On the other hand, only in Polish is there a sizeable set of prepositional demonstratives. Some of them, e.g. *przedtem* have an intransitive preposition counterpart in English -- *beforehand* -- but others, e.g. *wtedy* 'then', do not. Their counterparts, as was noted in Chapter 2 (pp. 48-49), are pronouns.

The P-PP and P- $\bar{S}$  structures in the two languages are not exploited in exactly the same way. Polish has a variety of complex prepositions which, combined with NP's, convey the meaning typically expressed by PP's with the P-PP structure in English (e.g. *spod stołu* 'from-under the table' vs *from under the table*). It is only where there is no suitable complex preposition that the P-PP structure occurs in Polish (e.g. *do po filmie* 'until after the film').

The P- $\bar{S}$  structure is also less wide-spread in Polish than in English but among Polish clausal constructions are PP's with no counterparts in English. These are PP's consisting of a demonstrative intransitive preposition and a modifying relative or appositive clause. They are part of a broader pattern, restricted to Polish, in which demonstratives of other categories -- NP, AP, and ADVP -- participate.

Another broad similarity between the two languages is the ability of PP's to appear as subjects and objects (cf. Chapter 7). This is a matter of some theoretical interest.

The occurrence of PP's in typical NP positions and the occurrence of intransitive prepositions and of  $\bar{S}$  complements of prepositions argue strongly for analyzing prepositions as heads of phrases. This position has been quite well-established as far as English is concerned since Jackendoff 1973, but not as far as Polish is concerned. If heads are the elements of a phrase which determine its identity and structure, then prepositions are heads in both languages since they fulfill both these roles in both languages.

It is likely that the main differences between English and Polish prepositions is in the area of extraction out of PP's, not discussed in the present thesis. It seems, however, that any discussion of this matter focussing on Polish will benefit from a recognition that

prepositions and PP's in the two languages are fundamentally alike in other respects.

### 10.3. Prepositions and PP's, and other categories

In the course of his demonstration that prepositions are not merely 'an annoying little surface peculiarity of English' (Jackendoff 1973: 345), Jackendoff lays some stress on similarities between prepositions and PP's on the one hand, and verbs and VP's on the other. It emerges from the present study that while the two types of category are similar to some extent, there are important differences between them as well as ways in which prepositions and PP's are more like the other main lexical and phrasal categories. Moreover, in at least two respects, prepositions are unique among lexical categories.

Jackendoff (1977: 81-82) is particularly concerned with subcategorization possibilities of prepositions and verbs. One relevant similarity that he highlights (1977: 32) is that both categories take an 'object', i.e. an NP.

In English, this property distinguishes prepositions and verbs from nouns and adjectives, which do not take an NP complement. An illustration is provided in (10.1) and (10.2) below, where we have examples containing nouns and adjectives related to verbs which take an NP.

- (10.1) a. He *sold the house*.  
       b. \* the *sale the house*  
       c. the *sale of the house*

- (10.2) a. He *likes* her.  
 b. \* He is *fond* her.  
 c. He is *fond of* her.

This generalization is too strong for Polish, where nouns and adjectives can take an NP complement. What distinguishes prepositions and verbs on the one hand from nouns and adjectives on the other in this language is that only the former pair can take an accusative NP as a complement.

Polański (1966: 92), Karolak (1984: 104), and Saloni and Świdziński (1985: 168) note that nouns related to verbs that take an accusative NP take a genitive NP complement, e.g.:

- (10.3) a. Sąsiedzi *sprzedali* dom.  
 neighbours sold house(ACC)  
 b. \* *sprzedaż* dom  
 sale house(ACC)  
 c. *sprzedaż* domu  
 sale house(GEN)

A relevant verb-adjective contrast is presented in (10.4).

- (10.4) a. Dziadek *zapewni* wnukom *mieszkanie*.  
 granddad will-ensure grandchildren(DAT) accommodation(ACC)  
 b. \* Wnuki są *pewne mieszkanie*.  
 grandchildren are sure accommodation(ACC)  
 c. Wnuki są *pewne mieszkania*.  
 grandchildren are sure accommodation(GEN)

The verb *zapewnić* 'ensure' takes an accusative NP but the related

adjective  *pewien*  'sure' takes a genitive NP. In other pairs, as in English, where a verb takes an (accusative) NP, the related adjective takes a PP complement. (10.5) illustrates.

(10.5) a.  *Organizm odparł atak choroby.*

organism resisted attack(ACC) illness

'The organism resisted an attack of the illness.'

b. \*  *Organizm był odporny atak choroby.*

organism was resistant attack(ACC) illness

c.  *Organizm był odporny na atak choroby.*

organism was resistant on attack(ACC) illness

'The organism was resistant to an attack of the illness.'

(In (10.5c), we have an example of a preposition taking an accusative NP complement.)

Given this minor qualification necessitated by the variety of case forms associated with Polish NP's, we can see that the contrast between prepositions and verbs on the one hand, and nouns and adjectives on the other with respect to NP complements is a matter of some significance.

In the preceding chapters, I have established that in addition to NP's, prepositions in both languages -- like verbs -- can take at least a PP or an  $\bar{S}$  complement or no complement at all. I have also, however, noted some differences between prepositions and verbs in their complement systems.

In Chapter 4 (pp. 130-131), I noted that prepositions do not take more than one complement whereas some verbs do (e.g.  *promise, apply,*  and  *buy*). I also suggested (p. 130) that, if items like  *because*  and  *although*  are analyzed as complementizers, and if  *away*  in  *away from NP*  is not analyzed as an instance of a preposition followed by a PP complement (cf. Chapter 3, pp. 79-84), then there are no prepositions that can take

a PP or an  $\bar{S}$  complement but not an NP complement

I mentioned these two points only in connection with English. It seems, however, that Polish prepositions and verbs differ in the same ways.

In allowing only one complement, prepositions seem to be like adjectives. They appear to be unique among lexical categories in allowing a non-NP complement (i.e. a PP or an  $\bar{S}$ ) only if they can take an NP complement as well.

In Chapters 4 (p. 125) and 6 (p. 167), I pointed out that prepositions like *before* and *podczas* 'during' can take a type of *wh*-movement clause that does not occur with verbs. I should add that, as far as I can see, there are no data in either English or Polish suggesting that this type of complement occurs with nouns or adjectives. In this respect also, then, prepositions are unique among lexical categories.

We turn now to the phrasal projections of prepositions and verbs, i.e. PP's and VP's.

PP's are unlike VP's in having demonstrative pro-forms. These were extensively discussed in connection with Polish in Chapters 2 and 6 because they constitute a sizeable set with properties consistent with the properties of the demonstratives of other categories in this language. Like the pro-nominal *to* 'this', the pro-adjectival *taki*, and the pro-adverbial *tak* 'so', the pro-prepositional items like *przedtem* 'beforehand' and *dlatego* 'therefore' allow a restrictive relative or an appositive clause as a modifier.

In English, such constructions do not occur. In the first place -- as has already been pointed out -- English probably does not have demonstrative prepositions. If we accept this position, then English PP's are like AP's, ADVP's, and VP's in that they do not have structures

with modifying clauses.

Where PP's and VP's differ from each other in both languages is in their distribution, a point touched on in Chapters 7 and 9.

We saw there that PP's can appear in three typical NP positions: subject, object, and object of a preposition. AP's and ADVP's are also -- to some extent -- possible in these positions (cf. Chapter 9, pp. 249-251 above). VP's, however, are not. One might suppose that the italicized strings in the following examples involve VP's in these positions:

- (10.6) a. *To err* is human.  
 b. He considered *to err* to be human.  
 c. Mark was about *to get lost*.

Given GB assumptions, however, these strings will be  $\bar{S}$ 's with PRO subjects.

Another position in which PP's but not VP's can appear is the adverbial position. PP's, NP's, and -- of course -- ADVP's appear in this position, but VP's do not. One might suppose that the italicized string in (10.7) is a VP in the adverbial position.

- (10.7) She was knocking on the wall *to attract* <sup>the</sup> *neighbours'*  
*attention.* (= (4.72))

Again, however, given GB assumptions, this will be an  $\bar{S}$  with a PRO subject.

The last position that we can mention is the COMP position, not referred to earlier. As noted in Radford (1981: 158), PP's -- like NP's, AP's and ADVP's -- can undergo *wh*-movement, but VP's cannot. The following illustrate:

- (10.8) a. [ $\bar{P}$  *To whom*] was Peter talking t?  
 b. [ $\bar{N}$  *Which flowers*] did he buy t?  
 c. [ $\bar{A}$  *How long*] was the lecture t?  
 d. [ $\bar{ADV}$  *How frequently*] do they meet t?  
 e. \* [ $\bar{V}$  *Do what*] will Peter t?

Again, there are examples which might be seen as suggesting that VP's too can appear in this position, for instance, the following from Nanni and Stillings (1978: 311):

- (10.9) The elegant parties, [*to be admitted to one of which*]  
 t was a privilege had usually been held  
 at Delmonico's. (= N&S's (3a))

Once more, however, the italicized constituent will -- within the GB assumptions -- be an  $\bar{S}$ .

We can conclude that prepositions are similar to verbs to some extent in their subcategorization properties and hence, that structures of PP's and VP's are similar. In their distribution, however, PP's are quite different from VP's and more like the other phrasal categories. Any theory of syntactic categories must accommodate these similarities and differences.

#### 10.4. Syntactic categories and the distribution of phrases

In a number of places in earlier chapters, I noted that the data that I considered provided evidence against two general principles that have been proposed in connection with the distribution of phrases: the Unlike Category Condition (cf. p. 84 above) and the Case Resistance Principle (cf. p. 86 above). PP's with the P-PP structure undermine the

UCC and PP's with the P-PP and the P- $\bar{S}$  structures as well as the occurrence of PP's as subjects and objects undermine the CRP.

Both these principles exclude specific syntactic categories from certain positions in sentence structure. Some of the data that I have discussed, however, cast doubt on the importance of syntactic categories in an account of the distribution of phrases. In particular, the data considered in Chapters 7 and 9 show that both subject and object position are positions in which any phrasal category (except for VP) can appear, provided it has the appropriate semantic properties (cf. p. 213 above). In other words, the meaning of a phrase appears to be of considerable importance in determining whether it can appear in a particular position.

This idea has been developed recently in Jackendoff 1983, 1985 and Pesetsky 1982, though without reference to subject and object PP's. It is appropriate, therefore, to consider Jackendoff's and Pesetsky's proposals in the light of the present work.

Jackendoff's proposal is that syntactic subcategorization frames typically involve underspecified categories (XP's), whose identity is largely predictable from what type of a semantic complement (or complements) a given lexical item takes. An illustration of this idea is presented in Jackendoff 1985, a work building on Jackendoff 1983.

Jackendoff 1985 examines the subcategorization properties of the verb *climb*. Syntactically, it can take an NP or a PP complement, or no complement at all. The following examples illustrate some of the uses of *climb*:

- (10.10) a. Bill climbed *the hill*. (= J's (19a))  
 b. Bill climbed *along the roof*. (= J's (19b))  
 c. Bill climbed *that way*. (= J's (19c))  
 d. Bill climbed. (= J's (19d))

Semantically, *climb* can take a 'Thing' or a 'Path' complement, or no complement at all. Things are expressed by NP's and Paths, normally, by PP's (cf. Chapter 7, pp. 211-212 above).

The lexical entry for *climb* contains a single syntactic subcategorization frame with an optional underspecified complement, [ $\_\_$  (XP)], and a semantic subcategorization frame with an optional choice of semantic complements. For the present purposes, simplifying the lexical entry in Jackendoff's (26b) considerably, we can represent *climb* as characterized in the lexicon in the following way:

$$(10.11) \left[ \begin{array}{l} \textit{climb} \\ [- N, + V] \\ + [\_\_ (XP)] \\ \left[ \_\_ \left( \left\{ \begin{array}{l} \textit{THING} \\ \textit{PATH} \end{array} \right\} \right) \right] \end{array} \right]$$

Depending on whether the object of climbing is a Thing or a Path, the post-verbal phrase will be an NP (cf. *the hill* in (10.10a)) or a PP (cf. *along the roof* in (10.10b)). Exceptionally, a Path can also be an NP (cf. *that way* in (10.10c)).

I mentioned in Chapter 7 (pp. 212) that Jackendoff 1985 considers both Paths and Places as typically realized by PP's. Thus, when the preposition *from* (or *na* 'for' in Polish) takes a Place complement, it is followed by a PP and when it takes a Thing complement, it is followed by an NP. Such an account appears to be quite plausible.

It appears to be quite easy to accommodate subject and object PP's within this framework. For the purpose of illustration, let us recall a pair of relevant examples, bearing in mind that the PP's there can alternate at least with NP's:

(10.12) a. *Between six and seven* will suit me. (= (7.2a))

b. The team wasted *from May to September* on the  
experiment. (= (7.40b))

We can say that the verb *suit* requires either a Thing or a Place subject, and the verb *waste* either a Thing or a (temporal or spatial) Place object. Accordingly, these positions will be filled by an NP or a PP.

Let us now turn to Pesetsky's (1982: 191-196) proposal, adopted by Chomsky (1985: 87-90) in his recent elaboration on the GB framework. Pesetsky considers the question of what determines the syntactic identity of a complement phrase. Of particular interest in the present context is his discussion of what determines the syntactic category of complements of verbs.

Building on work by Grimshaw 1979, he argues that this is predictable -- with one important exception -- from the type of semantic complement that a verb takes, and that syntactic subcategorization statements can be eliminated from the lexicon. This, then, is a stronger position than Jackendoff's, which assumes syntactic subcategorization statements with underspecified categories.

Pesetsky assumes that every semantic category is associated with one or more syntactic categories, which he calls 'Canonical Structural Realizations' (p. 185). For example, 'objects' are canonically realized as NP's and 'questions' as  $\bar{S}$ 's or NP's. Thus, if a verb selects a

'question', an  $\bar{S}$  will appear as its complement, e.g.,

- (10.13) a. John asked me [ $\bar{S}$  *what time it was*]. (= P's (265a))  
 b. John wondered [ $\bar{S}$  *what time it was*]. (= P's (266a))

or -- in some cases -- an NP:

- (10.14) a. John asked me [ $\bar{N}$  *the time*]. (= P's (265b))  
 b. \* John wondered [ $\bar{N}$  *the time*]. (= P's (266b))

The question that Pesetsky addresses (p. 191) in connection with these data is what prevents 'question' from being realized as an NP in (10.14b) while allowing an NP to appear in (10.13b).

He proposes (p. 192) that whether or not an NP can appear as a 'question' complement of a verb depends on whether or not the verb can assign Case: since *ask* but not *wonder* can assign Case, *ask* but not *wonder* can be followed by an NP complement. A structure containing a verb that does not assign Case and an NP complement with no Case is ruled out by the Case Filter. A structure containing a verb that does not assign Case and an  $\bar{S}$  complement is not ruled out by the Case Filter because -- within his assumptions --  $\bar{S}$ 's do not require Case.

One objection to this proposal arises from a consideration of verbs like *hope* in Chapter 9 (pp. 265-267), which form passive participles but do not take an NP complement (cf. *It is hoped that spring will come soon* vs *\*Everybody hopes the arrival of the spring*). Pesetsky assumes -- as I do (p. 238 above) -- that a verb can passivize only if it can assign Case. It follows from this assumption that *hope* must assign Case and hence that having the capacity to assign Case is not a sufficient condition for taking an NP. What seems to be required in this situation is a syntactic subcategorization statement in the lexical entry of *hope*, which would specify that only an  $\bar{S}$  (or a PP) can be its complement.

A further objection arises if one accepts the proposals of Chapter 8 (pp. 238-239), according to which Case-related properties of constituents are part of their syntactic feature make-up. Thus, syntactic subcategorization statements are necessary for the identification of those complements which must be moved in raising and passive constructions because they require Case and for ensuring that NP complements of verbs like *suit* and *fit* will bear Case although they will not be assigned Case by the verb (cf. pp. 243-244 above).

In view of these points, I conclude that Jackendoff's weaker position, within which lexical entries include partially specified subcategorization frames as well as information about the semantic type of complements, is preferable to Pesetsky's.

It should be noted, however, that Jackendoff's analysis of *climb* is not entirely satisfactory. As (10.15) illustrates, *climb* can be passivized when its complement is interpreted as Thing but not when it is interpreted as Path.

- (10.15) a. *The hill* was climbed by Bill.  
 b. \* *Along the roof* was climbed by Bill.  
 c. \* *That way* was climbed by Bill.

Given the proposals of Chapter 8, this means that the verb is [+ TRANS] and the complement is [CASE, ZERO] in the former case, while in the latter case, the verb is [- TRANS] and the complement has no Case feature specification. In view of this distinction, it is not so easy to propose a single lexical entry for *climb*.

One might, however, include in the entry the information that *climb* can be [+ TRANS] or [- TRANS], and include elsewhere in the grammar the statement that Thing is realized in the unmarked case as NP[CASE, ZERO]

rather than just a bare NP.

#### 10.5. Further research

In my discussion in this thesis, I hope to have illuminated some aspects of the syntax of prepositions and PP's in English and Polish. Obviously, however, I have not exhausted the topic. In Chapter 1 (p. 11), I mentioned a number of issues that I set aside. In this final section, I shall briefly indicate the other main areas for further research that suggest themselves at this point.

Earlier in this chapter, I have made various observations about similarities and differences between prepositions and PP's, and other lexical and phrasal categories. These matters merit further consideration especially in connection with attempts to construct a general theory of syntactic categories.

Also in this chapter, I have touched on some aspects of the relation between syntax and semantics. I have suggested that Jackendoff's position is preferable to the more radical position advanced by Pesetsky. Clearly, these two matters need further thought. In connection with this it is essential to specify a complete set of semantic types of constituents and their possible categorial realizations. It is worth investigating whether or not it is viable in languages like Polish, to construct single lexical entries for prepositions which have different meanings and can take NP complements in different case forms (e.g. the source preposition *z* takes a genitive NP complement but the accompaniment preposition *z* takes an instrumental NP).

Another matter that should be considered is the relation between the ideas developed here and those developed in Emonds 1985 and Chomsky 1986. As noted in Chapter 1 (p. 12), these are two major works potentially relevant to my investigations that became available to me too late to be discussed in the thesis.

On a more mundane level, there is the task of investigating the syntactic properties of further P-P-NP strings and of individual lexical items in various constructions in English and Polish in pursuit of adequate descriptions of the grammars and the lexicons of these languages.

It is important that the theoretical issues noted in the preceding paragraphs should be addressed. It is also important, however, that this more basic work should not be ignored.

## REFERENCES

*Note:* Where references in the text are to an edition of a book other than the first, the number of the edition used for references and its year of publication appear in square brackets.

- Akmajian, Adrian and Frank Heny. 1975. *An Introduction to the Principles of Syntax*. Cambridge, Mass.: MIT Press.
- Alletron, D.J. 1982. *Valency and the English Verb*. London: Academic Press.
- Anderson, Stephen R. and Paul Kiparsky (eds). 1973. *A Festschrift for Morris Halle*. New York: Holt, Rinehart & Winston.
- Aoun, Joseph and Dominique Sportiche. 1983. On the formal theory of government. *The Linguistic Review* 2. 211-236.
- Baltin, Mark. 1978. PP as a bounding node. *Proceedings from the Eighth Annual Meeting of the North Eastern Linguistic Society*, ed. by Mark J. Stein, 33-40. Amherst, Mass.: University of Massachusetts.
- Baker, C. Leroy. 1979. Syntactic theory and the projection problem. *Linguistic Inquiry* 10. 533-581.
- Bartnicka, Barbara. 1982. *Funkcje semantyczno-składniowe bezokolicznika we współczesnej polszczyźnie*. (Prace Językoznawcze 101.) Wrocław: Zakład Narodowy im. Ossolińskich.
- Becker, A.L. and D.G. Arms. 1969. Prepositions as predicates. *Papers from the Fifth Regional Meeting of the Chicago Linguistic Society*, ed. by Robert R.I. Binnick, Alice A. Davison, Georgia G.M. Green, and Jerry J.L. Morgan, 1-11. Chicago, Il.: Department of Linguistics, University of Chicago.

- Beukema, Frits. 1984. Small clauses and free adjuncts. *Linguistics in the Netherlands 1984* (Publications in Language Sciences 17), ed. by Hans Bennin and W.U.S van Lessen Kloeke, 13-21. Dordrecht: Foris.
- Bobrowski, Ireneusz. 1985. Review of *Gramatyka współczesnego języka polskiego: składnia*, ed. by Zuzanna Topolińska. *Język Polski* 65. 52-59.
- Borer, Hagit. 1984. Restrictive relatives in Modern Hebrew. *Natural Language & Linguistic Theory* 2. 219-260.
- Borsley, Robert D. 1984. Free relatives in Polish and English. *Contrastive Linguistics: Prospects and Problems*, ed. by Fisiak, 1-18.
- Borsley, Robert D. Forthcoming. A note on passives in GPSG. To appear in *York Papers in Linguistics*.
- Bresnan, Joan W. 1982a. The passive in lexical theory. *The Mental Representation of Grammatical Relations*, ed. by Bresnan, 3-86.
- Bresnan, Joan W. (ed.) 1982b. *The Mental Representation of Grammatical Relations*. (Cognitive Theory and Mental Representation Series.) Cambridge, Mass.: MIT Press.
- Bresnan, Joan W. and Jane Grimshaw. 1978. The syntax of free relatives in English. *Linguistic Inquiry* 9. 331-391.
- Brown, E. Keith. 1984. *Linguistics Today*. London: Fontana.
- Cann, Ronald. 1983. Raising in Latin: a phrase structure analysis of the accusative and infinitive. *Order, Concord and Constituency*, (Linguistic Models 4), ed. by Gerald Gazdar, Ewan Klein, and Geoffrey Pullum, 113-137. Dordrecht: Foris.
- Chametzky, Robert. 1985. NP's or arguments: exocentricity vs. predication. *Papers from the General Session at the Twenty-First Regional Meeting of the Chicago Linguistic Society*, ed. by Eilfort et al., 26-39.
- Chomsky, Noam. 1965. *Aspects of the Theory of Syntax*. Cambridge, Mass.:

MIT Press.

- Chomsky, Noam. 1968. *Language and Mind*. New York: Harcourt, Brace & World.
- Chomsky, Noam. 1970. Remarks on nominalization. *Readings in English Transformational Grammar*, ed. by Roderick A. Jakobson and Peter S. Rosenbaum, 184-221. Waltham, Mass.: Ginn.
- Chomsky, Noam. 1973. Conditions on transformations. *A Festschrift for Morris Halle*, ed. by Anderson and Kiparsky, 232-286. Also in *Essays on Form and Interpretation*, by Noam Chomsky (1977), 81-160. New York: North-Holland.
- Chomsky, Noam. 1977. On *wh*-movement. *Formal Syntax*, ed. by Culicover et al., 71-132.
- Chomsky, Noam. 1980. On binding. *Linguistic Inquiry* 11. 1-46. Also in *Binding and Filtering*, (Croom Helm Linguistics Series), ed. by Frank Heny (1981), 47-103. London: Croom Helm.
- Chomsky, Noam. 1981. *Lectures on Government and Binding*. (Studies in Generative Grammar 9.) Dordrecht: Foris.
- Chomsky, Noam. 1982. *Some Concepts and Consequences of the Theory of Government and Binding*. (Linguistic Inquiry Monograph 6.) Cambridge, Mass.: MIT Press.
- Chomsky, Noam. 1985. *Knowledge of Language: Its Nature, Origins and Use*. (Convergence.) New York: Praeger.
- Chomsky, Noam. 1986. *Barriers*. (Linguistic Inquiry Monograph 13.) Cambridge, Mass.: MIT Press.
- Cohen, L.J. 1981. Some remarks on the nature of linguistic theory. *Philosophical Transactions of the Royal Society of London B.295*. 235-243.
- Creswell, Max J. 1978. Prepositions and points of view. *Linguistics and Philosophy* 2. 1-41.

- Culicover, Peter W., Thomas Wasow, and Adrian Akmajian (eds). 1977. *Formal Syntax*. New York: Academic Press.
- Curme, George, O. 1935. *A Grammar of the English Language: Parts of Speech and Accidence*. Boston: D.C. Heath.
- Delahunty, Gerald P. 1983. But sentential subjects do exist. *Linguistic Analysis* 12. 379-398.
- Eilfort, William H., Kroeber, Paul D. and Karen L. Peterson (eds). 1985. *Papers from the General Session at the Twenty-First Regional Meeting of the Chicago Linguistic Society*. Chicago. Il.: Chicago Linguistic Society.
- Emonds, Joseph E. 1972. Evidence that indirect object movement is a structure-preserving rule. *Foundations of Language* 8. 546-561.
- Emonds, Joseph E. 1976. *A Transformational Approach to English Syntax: Root, Structure-Preserving, and Local Transformations*. New York: Academic Press.
- Emonds, Joseph E. 1985. *A Unified Theory of Syntactic Categories*. (Studies in Generative Grammar 19.) Dordrecht: Foris.
- Fillmore, Charles. 1968. The case for case. *Universals in Linguistic Theory*, ed. by Emon Bach and Robert Harms, 1-90. New York: Holt, Rinehart & Winston.
- Fisiak, Jacek (ed.) 1984. *Contrastive Linguistics: Prospects and Problems*. (Trends in Linguistics: Studies and Monographs 22.) Berlin: Mouton.
- Fisiak, Jacek, Maria Lipińska-Grzegorek, and Tadeusz Zabrocki. 1978. *An Introductory English-Polish Contrastive Grammar*. Warszawa: Państwowe Wydawnictwo Naukowe.
- Fromkin, Victoria and Robert Rodman. 1978. *An Introduction to Language*. New York: Holt, Rinehart & Winston.
- Gazdar, Gerald, Ewan Klein, Geoffrey K. Pullum, and Ivan A. Sag. 1985.

- Generalized Phrase Structure Grammar*. Oxford: Basil Blackwell.
- Gazdar, Gerald, Geoffrey K. Pullum, and Ivan A. Sag. 1982. Auxiliaries and related phenomena in a restrictive theory of grammar. *Language* 58. 591-638.
- Goldberg, Jeff. 1985. A nonsolution for a problem of PP extraction. *Linguistic Inquiry* 16. 478-481.
- Grimshaw, Jane. 1979. Complement selection and the lexicon. *Linguistic Inquiry* 10. 279-326.
- Grochowski, Maciej. 1977. O właściwościach syntaktycznych polskich spójników. *Polonica* 3. 17-25.
- Grochowski, Maciej. 1984a. Składnia wyrażen polipredykatywnych (zarys problematyki). *Gramatyka współczesnego języka polskiego: składnia*, ed. by Topolińska, 213-299.
- Grochowski, Maciej. 1984b. Projekt klasyfikacji syntaktycznej polskich leksemów nieodmiennych. *Polonica* 10. 73-79.
- Grzegorzczkowska, Renata. 1975. *Funkcje semantyczne i składniowe polskich przysłówków*. (Prace Językoznawcze 77.) Wrocław: Zakład Narodowy im. Ossolińskich.
- Grzegorzczkowska, Renata, Roman Laskowski, and Henryk Wróbel (eds). 1984. *Gramatyka współczesnego języka polskiego: morfologia*. Warszawa: Państwowe Wydawnictwo Naukowe.
- Grzegorek, Maria. 1984. *Thematization in English and Polish: A study in Word Order*. (Seria Filologia Angielska 18.) Poznań: Uniwersytet im. Adama Mickiewicza.
- Harris, Zellig. 1951. *Methods in Structural Linguistics*. Chicago, Il.: University of Chicago Press.
- Heinz, Adam. 1978. *Dzieje językoznawstwa w zarysie*. Warszawa: Państwowe Wydawnictwo Naukowe.
- Hendrick, Randall. 1976. Prepositions and the X' theory. *UCLA Papers in*

- Syntax 7: Proposals for Semantic and Syntactic Theory, ed. by Joseph E.monds, 95-122.
- Hoekstra, Teun. 1984. *Transitivity: Grammatical Relations in Government-Binding Theory*. (Linguistic Models 6.) Dordrecht: Foris.
- Huddleston, Rodney. 1984. *Introduction to the Grammar of English*. (Cambridge Textbooks in Linguistics.) Cambridge: CUP.
- Jackendoff, Ray S. 1972. *Semantic Interpretation in Generative Grammar*. Cambridge, Mass.: MIT Press.
- Jackendoff, Ray S. 1973. The base rules for prepositional phrases. A *Festschrift for Morris Halle*, ed. by Anderson and Kiparsky, 345-356.
- Jackendoff, Ray S. 1977.  $\bar{X}$  *Syntax: A Study of Phrase Structure*. (Linguistic Inquiry Monograph 2.) Cambridge, Mass.: MIT Press.
- Jackendoff, Ray S. 1983. *Semantics and Cognition*. (Current studies in Linguistics 8.) Cambridge, Mass.: MIT Press.
- Jackendoff, Ray S. 1985. Multiple subcategorization and the theta-criterion: the case of *climb*. *Natural Language & Linguistic Theory* 3. 271-295.
- Jaworska, Ewa. 1984. On the structure of adverbial subordinate constructions in English and Polish. *Contrastive Linguistics: Prospects and Problems*, ed. by Fisiak, 251-281.
- Jaworska, Ewa. Forthcoming. Prepositional phrases as subjects and objects. To appear in *Journal of Linguistics*.
- Jayaseelan, Karattuparambil A. 1983. Prepositions as deletion-triggers. *Linguistic Analysis* 11. 429-437.
- Jespersen, Otto. 1914. *A Modern English Grammar on Historical Principles: Syntax*. Vol. 1 [3rd edn, 1927]. Heidelberg: Carl Winters Universitätsbuchhandlung.
- Jespersen, Otto. 1924. *The Philosophy of Grammar*. London: George Allen & Unwin.
- Jespersen, Otto. 1927. *A Modern English Grammar on Historical Principles: Syntax*. Vol. 2. Heidelberg: Carl Winters

Universitätsbuchhandlung.

Jespersen, Otto. 1937. *Analytic Syntax*. London: George Allen & Unwin.

Jodłowski, Stanisław. 1976. *Podstawy polskiej składni*. Warszawa: Państwowe Wydawnictwo Naukowe.

Jodłowski, Stanisław and Witold Taszycki. 1956. *Zasady pisowni polskiej i interpunkcji ze słownikiem ortograficznym*. [17th edn, 1972]. Wrocław: Zakład Narodowy im. Ossolińskich.

Johnson, David. 1977. On relational constraints on grammar. *Grammatical Relations*, (Syntax and Semantics 8), ed. by Peter Cole and Jerrold Sadock, 151-178. New York: Academic Press.

Jurkowski, Marian. 1972. Przyimek i wyrażenie przyimkowe. *Z Polskich Studiów Sławistycznych*. 21-29.

Karolak, Stanisław. 1965. Przypadek a przyimek. *Biuletyn Polskiego Towarzystwa Językoznawczego* 23. 143-158.

Karolak, Stanisław. 1984. Składnia wyrażen predykatywnych. *Gramatyka współczesnego języka polskiego: składnia*, ed. by Topolińska, 11-211.

Klemensiewicz, Zenon. 1937. *Składnia opisowa współczesnej polszczyzny kulturalnej*. Kraków: Polska Akademia Umiejętności.

Klemensiewicz, Zenon. 1957. *Zarys składni polskiej*. [6th edn, 1969]. Warszawa: Państwowe Wydawnictwo Naukowe.

Klemensiewicz, Zenon. 1969. *Studia syntaktyczne*. Part 2. (Prace Komisji Językoznawstwa PAN -- Kraków 23.) Wrocław: Zakład Narodowy im. Ossolińskich.

Klima, Edward. 1965. *Studies in Diachronic Syntax*. Unpublished Ph.D. dissertation, Harvard University.

Koster, Jan. 1978. Why subject sentences don't exist. *Recent Transformational Studies in European Languages*, (Linguistic Inquiry Monograph 3), ed. by Samuel J. Keyser, 53-64. Cambridge, Mass.: MIT Press.

- Kuryłowicz, Jerzy. 1949. Le problème du classement des cas. *Biuletyn Polskiego Towarzystwa Językoznawczego* 9. 20-43. Also in *Esquisses linguistiques*, (Prace Językoznawcze 19), by Jerzy Kuryłowicz (1960), 131-150. Wrocław: Zakład Narodowy im. Ossolińskich.
- Larson, Richard K. 1985. Bare-NP adverbs. *Linguistic Inquiry* 16. 595-621.
- Laskowski, Roman. 1984a. Kategorie morfologiczne języka polskiego -- charakterystyka funkcjonalna. *Gramatyka współczesnego języka polskiego: morfologia*, ed. by Grzegorzczkova et al., 121-169.
- Laskowski, Roman. 1984b. Podstawowe pojęcia morfologii. *Gramatyka współczesnego języka polskiego: morfologia*, ed. by Grzegorzczkova et al., 9-57.
- Laskowski, Roman. 1984c. Predykatyw (czasownik). *Gramatyka współczesnego języka polskiego: morfologia*, ed. by Grzegorzczkova et al., 171-219.
- Lyons, John. 1981. *Language and Linguistics*. Cambridge: CUP.
- Mackenzie, J. Lachlan. 1975. On taking prepositions seriously: an examination of Jackendoff's base rules for prepositional phrases. *Work in Progress* 8. University of Edinburgh Department of Linguistics. 116-128.
- Maling, Joan. 1983. Transitive adjectives: a case of categorial reanalysis. *Linguistic Categories: Auxiliaries and Related Puzzles*, ed. by Frank Heny and Barry Richards. Vol. 1: Categories, 253-289. Dordrecht: Reidel.
- Mańczak, Witold. 1967. Gramatyka 'transformacyjna' a zdrowy rozsądek. *Język Polski* 47. 37-49.
- Marantz, Alec. 1982. Whither 'Move NP'? *MIT Working Papers in Linguistics* 4: *Papers in Syntax*, ed. by Alec Marantz and Timothy A. Stowell, 123-162. Cambridge, Mass.: MIT.
- Marantz, Alec. 1984. *On the Nature of Grammatical Relations*. (Linguistic

- Inquiry Monograph 10.) Cambridge, Mass.: MIT Press.
- McCawley, James D. 1982. The nonexistence of syntactic categories, *Thirty Million Theories of Grammar* (Croom Helm Linguistics Series), by James McCawley, 176-217. London: Croom Helm.
- McCawley, James D. 1985. Review of *Linguistic Categories: Auxiliaries and Related Puzzles*, ed. by Frank Heny and Barry Richards, 2 vols. *Language* 61. 849-862.
- Miller, J.E. 1985. *Semantics and Syntax: Parallels and Connections*. (Cambridge Studies in Linguistics 41.) Cambridge: CUP.
- Nanni, Debbie L. and Justine T. Stillings. 1978. Three remarks on pied piping. *Linguistic Inquiry* 9. 310-318.
- Newmeyer, Frederick J. 1983. *Grammatical Theory: Its Limits and Its Possibilities*. Chicago: University of Chicago Press.
- Nowakowska, Nina. 1981. Derywacja syntaktyczna w gramatyce generatywno-transformacyjnej. *Pojęcie derywacji w lingwistyce*, ed. by Jerzy Bartmiński, 55-70. Lublin: Wydawnictwo Uniwersytetu Marii Curie-Skłodowskiej.
- Ojeda, Almerindo E. 1983. On oblique relativization in Spanish. *Papers from the Nineteenth Regional Meeting of the Chicago Linguistic Society*, ed. by Amy Chukerman, Mitchell Marks, and John F. Richardson, 329-337. Chicago, Il.: Chicago Linguistic Society.
- Perlmutter, David M. 1980. Relational Grammar. *Current Approaches to Syntax*, (Syntax and Semantics 13), ed. by Edith A. Moravcsik and Jessica R. Wirth, 195-229. Orlando: Academic Press.
- Pesetsky, David M. 1982. *Paths and Categories*. Unpublished Ph.D. dissertation, MIT.
- Pinkham, Jessie and Jorge Hankamer. 1975. Deep and shallow clefts. *Papers from the Eleventh Meeting of the Chicago Linguistic Society*, ed. by Robin E. Grossman, L. James San, and Timothy J. Vance, 429-450.

- Chicago, Il.: Chicago Linguistic Society.
- Pisarkowie, Krystyna and Walery. 1966. Review of Noam Chomsky's *Aspects of the Theory of Syntax*. *Język Polski* 46. 234-241.
- Polański, Kazimierz. 1966. Główne typy struktur zdaniowych w języku polskim. *Zeszyty Naukowe Wyższej Szkoły Pedagogicznej w Katowicach* 31. (Prace Językoznawcze 3.) 83-99.
- Polański, Kazimierz. 1968. Problem klasyfikacji polskich zdań złożonych. *Sprawozdania Poznańskiego Towarzystwa Przyjaciół Nauk* 81. 288-292.
- Postal, Paul M. 1971. *Cross-Over Phenomena*. (Transatlantic Series in Linguistics.) New York: Holt, Rinehart & Winston.
- Postal, Paul M. 1977. About a 'Non-argument' for raising. *Linguistic Inquiry* 8. 141-154.
- Pullum, Geoffrey K. 1985. Assuming some version of X-bar theory. *Papers from the General Session at the Twenty-First Regional Meeting of the Chicago Linguistic Society*, ed. by Eilfort et al., 323-353.
- Quirk, Randolph, Sidney Greenbaum, Geoffrey Leech, and Jan Svartvik. 1972. *A Grammar of Contemporary English*. London: Longman.
- Quirk, Randolph, Sidney Greenbaum, Geoffrey Leech, and Jan Svartvik. 1985. *A Comprehensive Grammar of the English Language*. London: Longman.
- Radford, Andrew. 1981. *Transformational Syntax: A Student's Guide to Chomsky's Extended Standard Theory*. (Cambridge Textbooks in Linguistics.) Cambridge: CUP.
- Richardson, John F. 1984. Let  $\bar{X}=\bar{X}$ . *Papers from the Twentieth Regional meeting of the Chicago Linguistic Society*, ed. by Joseph Drogo, Veena Mishra, and David Testen, 321-333. Chicago, Il.: Chicago Linguistic Society.
- Riemsdijk, Henk C. van. 1978. *A Case Study in Syntactic Markedness: The Binding Nature of Prepositional Phrases*. (Studies in Generative

- Grammar 4.) Lisse: Peter de Ridder.
- Rosenbaum, Peter. 1967. *The Grammar of English Predicate Complement constructions*. Cambridge, Mass.: MIT Press.
- Ross, John R. 1967. *Constraints on Variables in Syntax*. Unpublished Ph.D. dissertation, MIT. [Distributed by Indiana University Linguistics Club.]
- Safir, Kenneth J. 1983. On small clauses as constituents. *Linguistic Inquiry* 14. 730-735.
- Safir, Kenneth J. 1985. *Syntactic Chains*. (Cambridge Studies in Linguistics 40.) Cambridge: CUP.
- Sag, Ivan A. 1982. Coordination, extraction, and Generalized Phrase Structure Grammar. *Linguistic Inquiry* 13. 329-335.
- Sag, Ivan A., Gerald Gazdar, Thomas Wasow, and Steven Weisler. 1985. Coordination and how to distinguish categories. *Natural Language & Linguistic Theory* 3. 117-171.
- Saloni, Zygmunt. 1974. Klasyfikacja gramatyczna leksemów polskich. *Język Polski* 54. 3-13, 93-101.
- Saloni, Zygmunt and Marek Świdziński. 1985. *Składnia współczesnego języka polskiego*. Warszawa: Państwowe Wydawnictwo Naukowe.
- Sambor, Jadwiga. 1971. Z zagadnień gramatyki w słowniku frekwencyjnym współczesnego języka polskiego. *Biuletyn Polskiego Towarzystwa Językoznawczego* 29. 117-129.
- Schwartz, Arthur. 1972. Constraints on movement transformations. *Journal of Linguistics* 8. 35-85.
- Stowell, Timothy A. 1981. *Origins of phrase structure*. Unpublished Ph.D. dissertation, MIT.
- Szober, Stanisław. 1923. *Gramatyka języka polskiego*. [12th edn, 1962]. Warszawa: Państwowe Wydawnictwo Naukowe.
- Szwedek, Andrzej. 1974. A note on the relation between the article in

- English and word order in Polish. *Papers and Studies in Contrastive Linguistics* 2. 213-225.
- Taraldsen, Knud T. 1984. The internal structure and external distribution of tensed clausal complements in English, French and Norwegian. *Sentential Complementation: Proceedings of the International Conference Held at UFSAL, Brussels, June 1983*, (Linguistic Models 5), ed. by W. de Geest and Y. Putseys, 239-246. Dordrecht: Foris.
- Topolińska, Zuzanna. 1984a. Składnia grupy imiennej. *Gramatyka współczesnego języka polskiego: składnia*, ed. by Topolińska, 301-389.
- Topolińska, Zuzanna (ed.) 1984b. *Gramatyka współczesnego języka polskiego: składnia*. Warszawa: Państwowe Wydawnictwo Naukowe.
- Waksberg, Judith. 1977. The structure of prepositional phrases in the X bar theory. Unpublished paper, Brandeis University.
- Walczak, Grzegorz. 1975. Perintegracja syntaktyczna. *Biuletyn Polskiego Towarzystwa Językoznawczego* 32. 53-69.
- Wasow, Thomas. 1977. Transformations and the lexicon. *Formal Syntax*. ed. by Culicover et al., 327-361.
- Wątor, Ignacy. 1969. Polskie przyimki odwyrażeniowe. *Język Polski* 49. 372-378.
- Williams, Edwin. 1979. Passive. Unpublished paper, University of Massachusetts, Amherst.
- Williams, Edwin. 1983a. Against small clauses. *Linguistic Inquiry* 14. 287-308.
- Williams, Edwin. 1983b. Semantic vs. syntactic categories. *Linguistics and Philosophy* 6. 423-446.
- Williams, Edwin. 1984. Grammatical relations. *Linguistic Inquiry* 15. 639-673.

Zabrocki, Tadeusz. 1981. *Lexical Rules of Semantic Interpretation: Control and NP-movement in English and Polish*. (Seria Filologia Angielska 14.) Poznań: Wydawnictwo Naukowe Uniwersytetu im. A. Mickiewicza.