

**The Synthesis of (±)-Trichoviridin, WF-10129 and a Biologically Active
Analogue of Antibiotic A-32390A**

A thesis submitted to the
Board of the Faculty of Physical Sciences
in partial fulfilment
of the requirements for the degree of

DOCTOR OF PHILOSOPHY

in the

UNIVERSITY OF OXFORD

by

Marie-Louise Smith

Wolfson College
Oxford

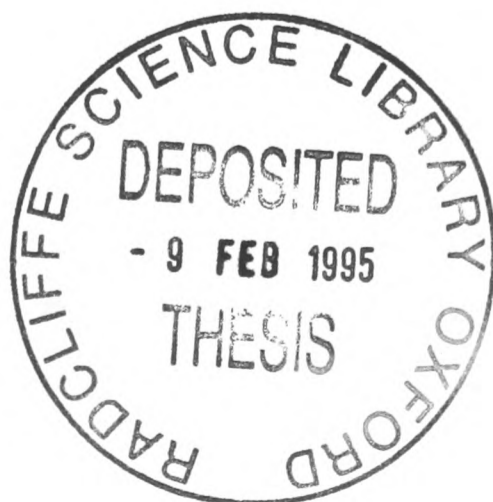

The Dyson Perrins Laboratory
November 1994

ABSTRACT

Marie-Louise Smith
Wolfson College, Oxford

D.Phil.
Trinity 1994

THE SYNTHESIS OF (±)-TRICHOVIRIDIN, WF-10129 AND A BIOLOGICALLY
ACTIVE ANALOGUE OF ANTIBIOTIC A-32390A

This thesis is divided into two parts:

Part 1

(i) The Synthesis of a Biologically Active Analogue of Antibiotic A-32390A

Methodology for the preparation of vinyl formamides from thiooximes has been developed for use with α -carboxy systems and successfully applied to the synthesis of (2*S*, 3*S*)-2,3-di-[hydroxybutane]-1,4-di-[2-isocyano-3-methyl-but-2-enoate], a vinyl isonitrile that is a biologically active analogue of the natural product, antibiotic A-32390A. In addition trifluoromethane sulfonic anhydride has been shown to be an effective reagent for the dehydration of vinyl formamides to vinyl isonitriles in these systems.

(ii) The Synthesis of (±)-Isonitrin C (Trichoviridin)

Further application of the methodology for the synthesis of vinyl formamides from thiooximes allowed for the effective preparation of 1 α -(1'-*t*-butyldimethylsilyloxyethyl)-2 β , 3 β -epoxy-4-en-4-isocyano-cyclopentan-1 β -ol, a key intermediate in the syntheses of the naturally occurring vinyl isonitriles, (±)-isonitrin A and (±)-isonitrin B. New methodology was developed for the synthesis of the epoxy-isonitrile functionality of (±)-isonitrin C (trichoviridin). Masking of the isonitrile functionality of 1 α -(1'-*t*-butyldimethylsilyloxyethyl)-2 β , 3 β -epoxy-4-en-4-isocyano-cyclopentan-1 β -ol by formation of the corresponding dibromoimine was followed by epoxidation of the C-C double bond with methyl (trifluoromethyl)dioxirane and removal of the bromine groups to regenerate the isonitrile moiety. Deprotection afforded (±)-isonitrin C (trichoviridin).

(iii) Mechanism of the Thiooxime Rearrangement

Some insight into the mechanism of the thiooxime rearrangement was obtained by ¹³C n.m.r. experiments and elucidation of the reaction by-products.

Part II

A flexible route to optically pure γ -keto- α -amino acids using carbon based nucleophilic ring opening of activated monocyclic β -lactams has been established. Nucleophiles examined include lithiated sulfones, Lipshutz higher order organocuprates and lithiated phosphonates. This methodology has been applied to a high yielding synthesis of the naturally occurring potent ACE inhibitor WF-10129. The stereochemistry of WF-10129 was established, by synthesis of all possible diastereomers, to be *S* at all stereocentres.

DEDICATED TO

Mum, Dad and Danny

ACKNOWLEDGEMENTS

I am indebted to Professor J.E. Baldwin FRS for giving me the opportunity of working in his laboratories, for the provision of excellent facilities throughout my time in the DP and for my conscription into the front line!

I would like to express my sincere gratitude and thanks to Dr. Rob Adlington for his excellent supervision over the last three years (particularly in times of adversity).

Special thanks go to Dr. Andy Russell for all the time and energy he has devoted to these projects and for his "day to day" advice and encouragement.

I would like to express my appreciation to Rob Adlington, Andy Russell, Roger Whitehead and Danny Marquess for proof-reading this thesis.

I must thank Zeneca Pharmaceuticals and the SERC for financial support.

I would also like to thank Mrs. Elizabeth McGuinness and Richard Chesworth for high-field n.m.r. experiments, Robin Aplin and Robin Procter for mass spectral determinations, Valerie Lamburn for the microanalyses and the other technical staff at the DP, particularly Levi and Alan for their good humour. I am also very grateful to Bill and Paul for help with the molecular modelling.

Many thanks to the members of Room 30 and 71 for making this an enjoyable and memorable three years particularly Gareth (for hugs and ice-cream), Snappy, Al, Ches and Mark (for their intriguing digestive systems), Jemmy, Twitch and Roger, Victor, Andy, Deqi, Mark, Kirsten, Winston, Jan, Mike, Nick, Ali, Bill, Jason, Von G, Spanner, Kate and uuuuummm Colin.

Finally, I would like to thank Dan(ny) for his love and support.

TABLE OF CONTENTS**PART I**

Chapter 1 Isonitriles as Natural Products	1
1.1 Introduction	1
1.2 Isonitriles from Eukaryotes	1
1.2.1 Isonitriles from Fungi	1
1.2.2 Isonitriles from Marine Sponges and Nudibranches	7
1.3 Isonitriles from Prokaryotes	11
1.3.1 Isonitriles from Blue-Green Algae (Cyanobacteria)	11
1.3.2 Isonitriles from Bacteria	15
1.3.2.1 Isonitriles from Actinomycetes	15
1.3.2.2 Isonitriles from Other Bacterial Types	17
1.4 Conclusion On The Biosynthesis of Isonitriles	18
Chapter 2 The Synthesis of Isonitriles	19
2.1 Introduction	19
2.2 Isonitrile Synthesis by Dehydration of Formamides	19
2.2.1 The Synthesis of Isonitriles Attached to a Saturated Carbon	21
2.2.2 Vinyl Isonitrile Synthesis	27
2.2.3 Epoxy Isonitriles Synthesis	33
2.2.4 α -Heteroatom Substituted Isonitrile Synthesis	35
2.3 Isonitrile Synthesis using Organometallic Cyanide	35
2.4 Isonitrile Synthesis from Carbonic Acid Derivatives	37
2.5 Isonitrile Synthesis using Metallated Isonitriles	
(With Retention of the Isonitrile Group)	41
2.6 Isonitrile Synthesis by Displacement of Halide with Cyanide	42

2.7	Isonitrile Synthesis using the Hofmann Carbylamine Reaction	43
2.8	Other Methods for the Preparation of Isonitriles	44
Chapter 3 The Synthesis of a Biologically Active Analogue of Antibiotic A-32390A		
3.1	Antibiotic A-3290A-Isolation and Biological Activity	45
3.2	Schöllkopf's Synthesis of A-32390A and Analogues	45
3.3	Previous Work Toward a Biologically Active Analogue of A-32390A	46
3.3.1	Introduction	46
3.3.2	Background to the Baldwin Thioxime to Vinyl Formamide Rearrangement	48
3.3.3	Preliminary Evaluation	49
3.3.4	Preliminary Studies Towards the Synthesis of a Biologically Active Analogue of Antibiotic A-32390A	51
3.4	Completion of the Synthesis of a Biologically Active Analogue of Antibiotic A-32390A	54
3.5	Concluding Remarks	68
Chapter 4 The Synthesis of (±)-Isonitrin C (Trichoviridin)		
4.1	The Isonitrins-Isolation and Biological Activity	70
4.2	Synthetic Strategy for the Isonitrins-Retrosynthetic Analysis	71
4.3	Previous Synthesis of (±)-Isonitrin B (Deoxytrichoviridin)	72
4.4	Previous Synthesis of (±)-Isonitrin A	74
4.5	Completion of the Synthesis of (±)-Isonitrin C (Trichoviridin)	74
4.5.1	Improved Synthesis of the Key Amine Intermediate	74
4.5.2	Improved Synthesis of the Vinyl Formamide	78
4.5.3	Improved Synthesis of the Vinyl Isonitrile	81
4.5.4	Attempted Epoxidation/Dehydration of the Vinyl Formamide	82

4.5.5	Epoxidation of an Isonitrile Derivative	91
4.5.5.1	The Dichloromine as an Isonitrile "Protecting Group"	92
4.5.5.2	Photolabile "Protecting Groups" for Isonitriles	95
4.5.5.3	The Dibromoimine as an Isonitrile "Protecting Group"	99

Chapter 5 Mechanism of the Thiooxime Rearrangement 106

5.1	Introduction	106
5.2	Summary of Previous Work	109
5.3	¹³ C Experiments and Elucidation of Reaction By-Products	112
5.4	Proposed Mechanism	113
5.5	Conclusion	116

Chapter 6 Experimental for Part I 119

6.1	General Experimental Techniques for Part I and Part II	119
6.2	Experimental Procedures	121
6.2.1	Studies Towards the Synthesis of (X), a Biologically Active Analogue of Antibiotic A-32390A	121
6.2.2	Studies Towards the Synthesis of (±)-Isonitrin C (Trichloviridin)	134
6.2.3	Studies towards the Synthesis of the Thiooxime Rearrangement	164

Chapter 7 References for Part I 166

PART II

Chapter 8 Inhibitors of Angiotensin Converting Enzyme (ACE) 1

8.1	Introduction	1
8.2	First Generation ACE Inhibitors	2
8.3	Second Generation ACE Inhibitors	5
8.4	Naturally Occurring ACE Inhibitors	7

8.5	WF-10129, a Naturally Occurring ACE Inhibitor	9
8.5.1	Isolation, Structure and Biological Activity	9
8.5.2	Retrosynthetic Analysis of WF-10129	10
Chapter 9 γ-Keto α-Amino Acids		12
9.1	Non-Proteinogenic Amino Acids	12
9.2	γ-Keto α-Amino Acids as Natural Products	12
9.3	Syntheses of γ-Keto α-Amino Acids	15
9.3.1	Application of Glycine Cation Equivalents	15
9.3.2	Application of Glycine Anion Equivalents	18
9.3.3	Application of Aspartic Acid Derivatives	19
9.3.4	Application of β -Alanine Equivalents	26
Chapter 10 Carbon Based Nucleophilic Ring Opening of Activated Monocyclic β-lactams; Synthesis and Stereochemical Assignment of the ACE Inhibitor WF-10129		28
10.1	The β-lactam as a Chiral Synthone	28
10.2	Synthesis of γ-Keto-α-Amino Acids <i>via</i> Carbon Based Nucleophilic Ring Opening of Activated Monocyclic β-Lactams	33
10.2.1	β -Lactam Ring Opening with a Sulphur Ylide	33
10.2.2	β -Lactam Ring Opening with Lithiated Sulphones	41
10.2.3	β -Lactam Ring Opening with Lithiated Phosphonates; Synthesis of the Enantiomer of a Potent NMDA Antagonist	51
10.2.4	β -Lactam Ring Opening with Cuprates	53
10.3	Confirmation of the Stereochemistry and Structure of WF-10129 Through Total Synthesis	55
10.3.1	Introduction	55
10.3.2	Synthesis of Diastereoisomers (20a)	57
10.3.3	Synthesis of Diastereoisomers (20b), <i>ent</i> -(20c) and <i>ent</i> -(20d)	59

10.4	Assignment of the Stereochemistry of WF-10129	62
10.5	Concluding Remarks	63
Chapter 11 Experimental for Part II		64
11.1	Experimental Procedures	64
Chapter 12 References for Part II		130

GLOSSARY

Å	ångström
AB	AB system (n.m.r.)
Ac	acetyl
AIBN	2,2'-azobis- <i>iso</i> -butyronitrile
aq.	aqueous
Ar	aryl
atm.	atmospheres of pressure
Boc	<i>tert</i> -butoxycarbonyl
Bn	benzyl
Bz	benzoate
b.p.	boiling point
br	broad
<i>n</i> -Bu	normal-butyl
<i>t</i> -Bu	tertiary-butyl
BuLi	butyllithium
<i>c</i>	concentration
<i>ca.</i>	circa (Latin: about)
Celite®	high grade diatomaceous earth used as a filter aid

<i>m</i> -CPBA	<i>meta</i> -chlorobenzoic acid
cm ⁻¹	wavenumber
COSY	correlation spectroscopy
CSA	camphor sulfonic acid
d	doublet (n.m.r.)
d.e.	diastereomeric excess
DABCO	1,4-diazabicyclo[2.2.2]octane
DBU	1,8-diazabicyclo[5.4.0]undec-7-ene
DCC	1,3-dicyclohexylcarbodiimide
DCM	dichloromethane
DEPT	distortionless enhancement by polarisation transfer
DIBAL	diisobutylaluminium hydride
DMAP	4-(<i>N,N</i> -dimethylamino)pyridine
DMF	<i>N,N</i> -dimethylformamide
DMSO	dimethylsulfoxide
DPPA	diphenylphosphoryl azide
DVB	divinylbenzene
Et	ethyl
Et ₂ O	diethyl ether
EtOAc	ethyl acetate
<i>et al.</i>	<i>et alia</i> (Latin: and others)
<i>etc.</i>	<i>et cetera</i> (Latin: and so on)
eq.	equivalents
FT IR	fourier transform infra red
g	gram
HOBt	1-hydroxybenzotriazole
h.p.l.c.	high performance (pressure) liquid chromatography
HMDS	hexamethyldisilazide
HMPA	hexamethyl

<i>i.e.</i>	<i>id est</i> (Latin: that is)
<i>inter alia</i>	Latin: among other things
J	coupling constant
LDA	lithium diisopropylamide
lit.	literature (reference)
m	multiplet (n.m.r.), medium (IR)
M ⁺	molecular ion
max.	maximum
Me	methyl
mg	milligram
MH ⁺	protonated molecular ion
mmHg	millimetres of mercury
mmol	millimole
m.p.	melting point
m/z	mass/charge ratio
n.m.r.	nuclear magnetic resonance
n.O.e.	nuclear Overhauser effect
ODS	octadecylsilyl
PDC	pyridinium dichlorochromate
PEP	phosphoenol pyruvate
Ph	phenyl
PhFl	phenylfluorenyl
PMB	<i>para</i> -methoxybenzyl
ppm	parts per million
<i>i</i> -Pr	<i>iso</i> -propyl
q	quartet (n.m.r.)
R	alkyl substituent
Red-Al	sodium bis(2-methoxyethoxy)aluminium hydride
R _f	retention factor

RT	room temperature
s	singlet (n.m.r.), strong (IR)
Selectride®	tri- <i>sec</i> -butylborohydride
SEM	2-(trimethylsilyl)ethoxymethylene
t	triplet (n.m.r.)
TBAF	tetra- <i>n</i> -butylammonium fluoride
TBDMS	<i>tert</i> -butyldimethylsilyl
TBDPS	<i>tert</i> -butyldiphenylsilyl
Tf or triflate	trifluoromethane sulfonate
TFA	trifluoroacetic acid
Th	thienyl
THF	tetrahydrofuran
t.l.c.	thin layer chromatography
TMS	trimethylsilyl
Tol	tolyl
TOSMIC	<i>p</i> -toluenesulfonylmethyl isocyanide
<i>p</i> -Ts	<i>p</i> -toluenesulfonyl (tosyl)
Tz	tetrazole
Z	benzyloxycarbonyl

PART I

Chapter 1

Isonitriles as Natural Products**1.1 Introduction**

Secondary metabolites containing the isonitrile (or isocyanide) group occur relatively rarely in nature although, in contrast to the more familiar nitriles, they are found in taxonomically diverse organisms. The isonitriles exhibit wide ranging and often potent biological activity with the majority being isolated and identified as a result of the systematic search for pharmacologically interesting compounds that has taken place over the last few decades.

Naturally occurring isonitriles were the subject of a review by Edenborough and Herbert published in 1988¹ in which they were classified as being derived from either marine or terrestrial sources, a division which appeared to be in agreement with their differing biosynthetic origins. Studies with more recently discovered isonitriles, most notably those from blue-green algae, suggest that this division is over simplified at least on biogenetic grounds. Consequently, the following discussion will divide the isonitriles according to the type of organisms from which they derive.

1.2 Isonitriles from Eukaryotes**1.2.1 Isonitriles from Fungi***Isolation*

The first isonitrile metabolite was isolated in 1950 by Rothe from a culture of *Penicillium notatum* Westling and was called xanthocillin.² It was subsequently shown, however, to be a complex mixture composed mainly of xanthocillins X, Y1 and Y2.^{3,4} The structure of xanthocillin X (1) was elucidated by chemical degradation by Hagedorn and

Tönjes^{5,6} and later confirmed by X-ray analysis.⁷ The structures (6) and (7) have been proposed for Y1 and Y2,⁸ Figure 1.

Xanthocillin X (1) was the first of what is now a family of structurally related compounds.¹ Other members include xanthocillin X dimethyl ether (2),⁹⁻¹³ xanthocillin X monomethyl ether (3),^{9,10,14-16} and methoxyxanthocillin X dimethylether (4),^{9,10} BU-4704 (5),¹⁷ antibiotic MK4588 (8)¹⁸ and xanthoascin (9),¹⁹ Figure 1. Many of the xanthocillins show interesting biological profiles. Xanthocillin, for example, shows a wide spectrum of activity against Gram positive and Gram negative bacteria, fungi and yeasts²⁰ including microorganisms which have developed resistance to penicillins and sulfonamides^{21,22} and is now marketed in Germany as a broad spectrum antibiotic under the trade names Brevicid and Tyrocid-X.⁸

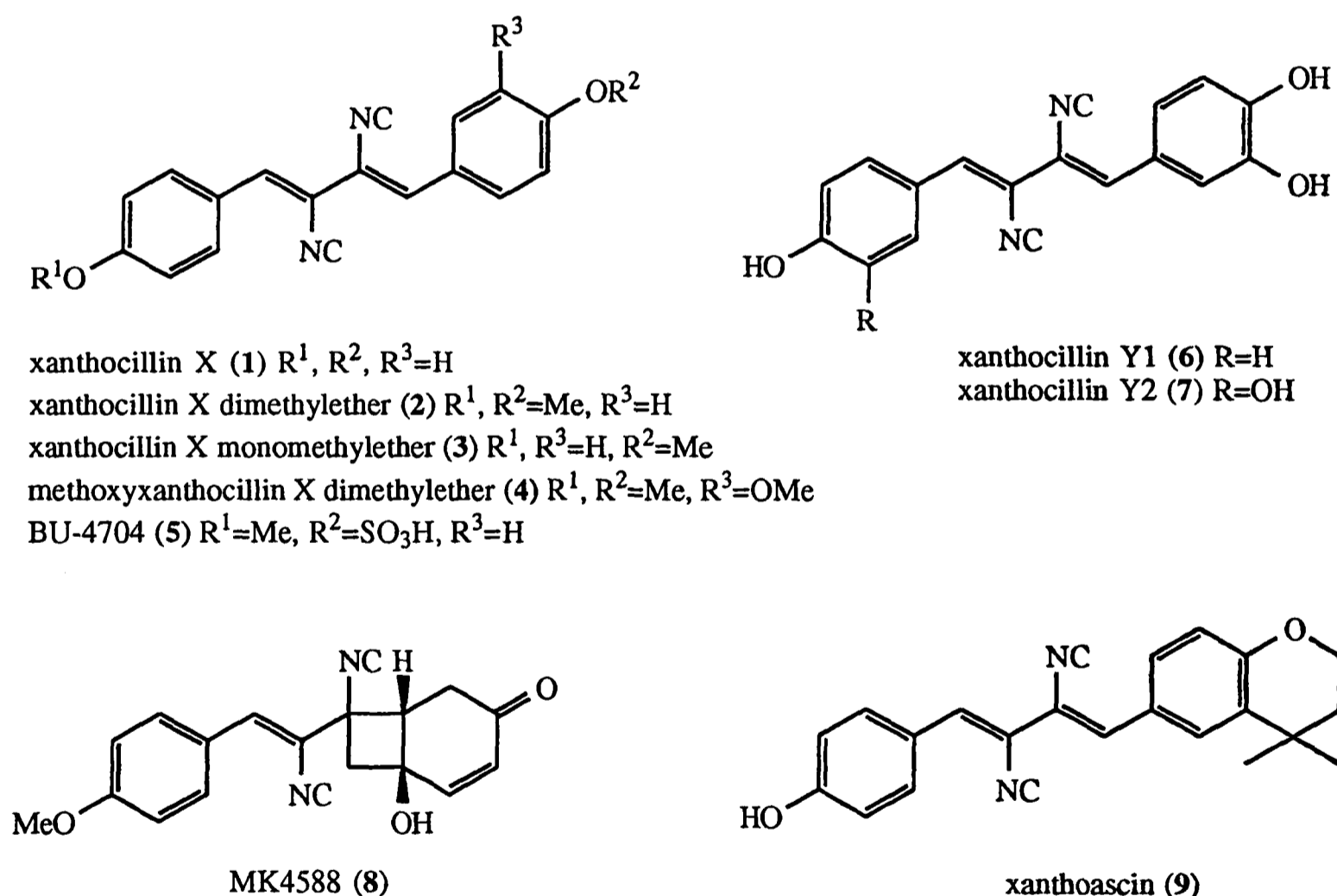

Figure 1

Another family of fungal isonitriles are the unstable cyclopentyl metabolites obtained from fungi of the genus *Trichoderma*^{1,23} e.g. (10)-(17), Figure 2. These compounds vary in molecular complexity from isonitrile 270 (10)^{24,25} to trichoviridin (16)²⁵⁻²⁹ which is surely one of the most complex small molecules known. Trichoviridin and its less oxygenated

congeners, known as isonitrins A (14)^{25,30} and B (15),^{25,31} will be discussed in more detail in Chapter 4.

The antibiotic activity associated with the cyclopentyl metabolites is believed to lead to ovine ill thrift, a sheep disease studied by Brewer and Taylor.^{32,33,34} Grazing on seemingly rich pasture, the afflicted sheep nevertheless do not thrive. It was discovered that in pastures where the disease is common a large amount of trichoderma species were present. Inhibition of the growth of the cellulose digesting bacteria in the rumen of the sheep by the fungal metabolites is the likely cause.^{35,36} These metabolites have also been implicated in the aetiology of the widespread root-rot disease caused by the soil-borne fungus *Phytophthora cinnamomi* Rands.³⁷

Recent work by Taylor with the *Trichoderma* moulds has led to the isolation of some unstable isonitriles (e.g. (10)³⁵) as rhodium or palladium complexes. X-ray analysis of the stable crystalline complex or spectroscopy was then used to elucidate the structures which are otherwise difficult to characterise.^{38,39}

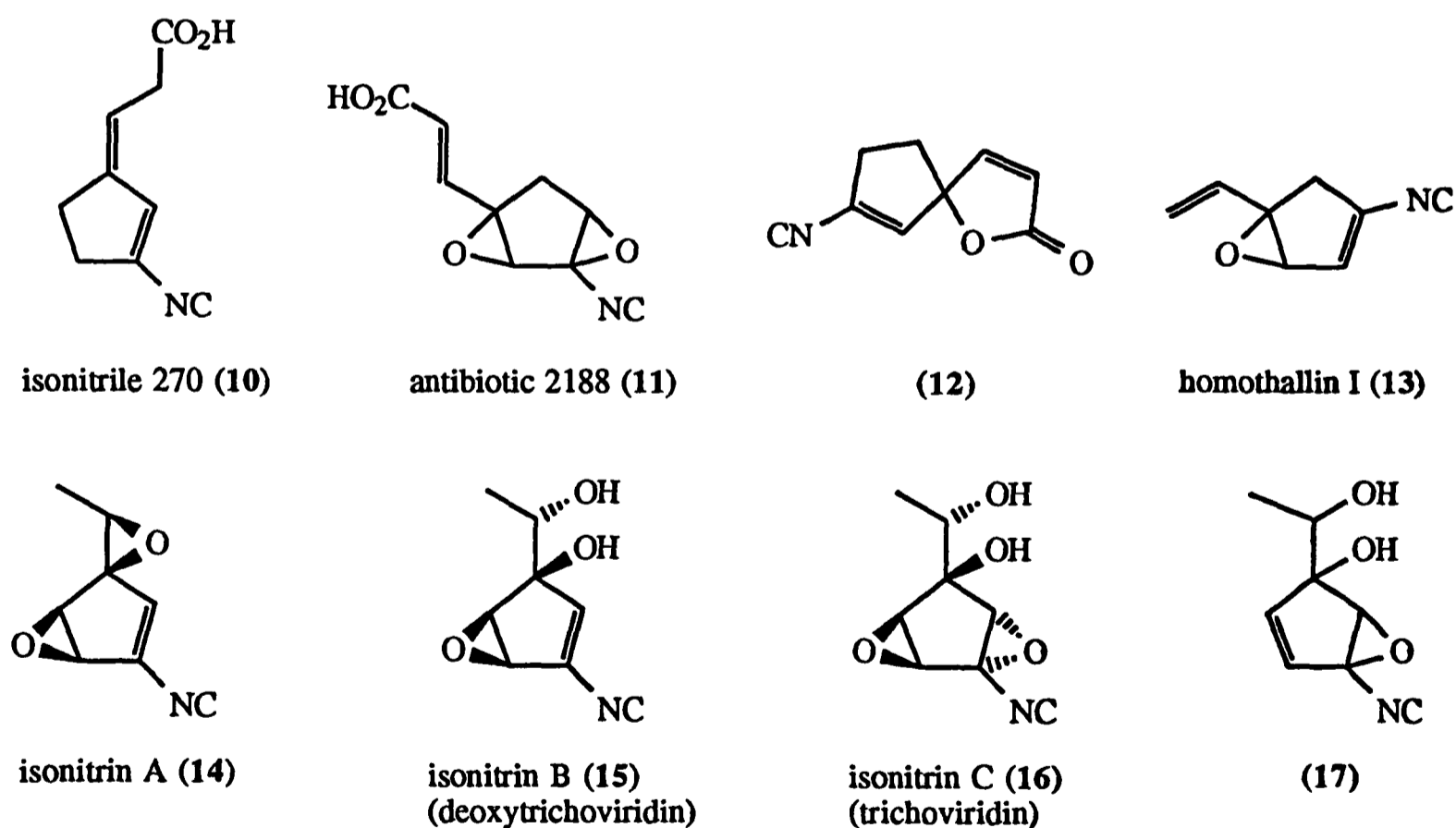
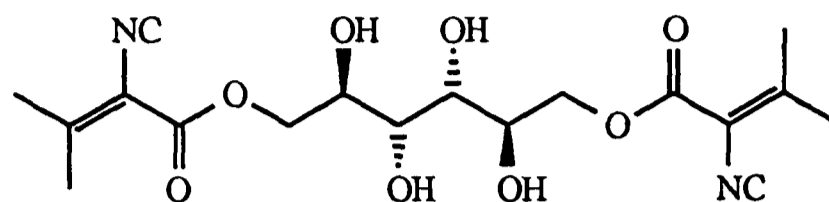

Figure 2

The remaining isonitriles obtained from fungal sources are two derivatives of mannitol, namely antibiotic A-32390A (18), from an organism of the genus *Pyranochaeta*,⁴⁰

and brassicolin A (19),⁴¹ recently obtained from the fungus *Alternaria brassicicola*, Figure 3. Antibiotic A-32390A (18) will be discussed in more detail in Chapter 3.



antibiotic A-32390A (18)

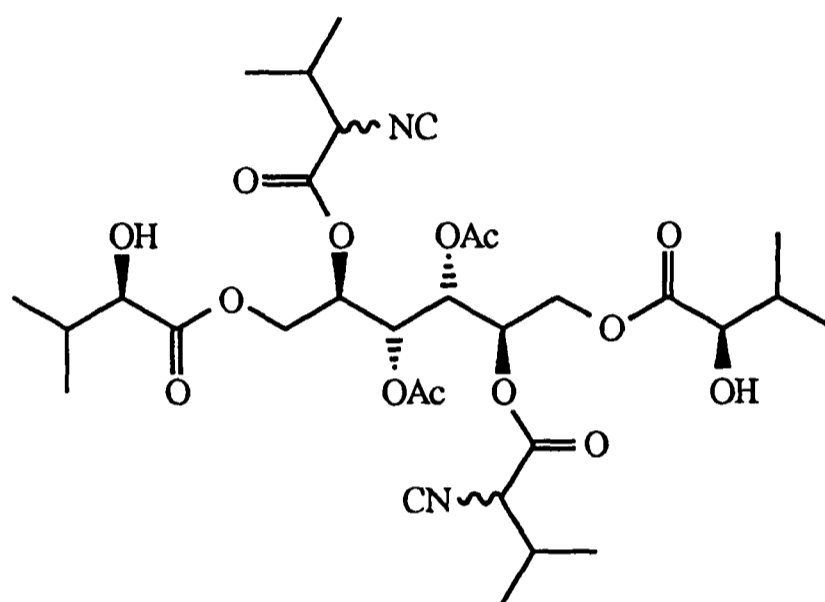

brassicolin A (19)

Figure 3

Biosynthesis

The structures of a large number of the isonitriles from yeasts and fungi strongly suggest a relationship with amino acids, for example xanthocillin X (1) with tyrosine and A-32390A (18) with valine. This leads readily to the hypothesis that they are derived from the metabolism of amino acids.

Achenbach and Grisebach have shown that (*DL*)-[2-¹⁴C]tyrosine does indeed serve as an excellent precursor for the 1,4-diarylbutadiene portion of xanthocillin X (1) in *Penicillium notatum*. In contrast, (*DL*)-[1-¹⁴C]tyrosine was not incorporated indicating that the amino acid is decarboxylated *en route* to the xanthocillins and C-1 of tyrosine does not become the isonitrile carbon.⁴²

The origin of the isonitrile group in xanthocillin X monomethylether (3) from *Dichotomomyces cejprii* has been thoroughly investigated by Herbert. Initial studies showed

that C-1 metabolites associated with tetrahydrofolate metabolism (*i.e.* C-2 of glycine, C-3 of serine, formate, and methionine) labelled only the *O*-methyl group and not the isonitrile carbon. Other potential C₁ sources (potassium [¹⁴C]cyanate, [¹⁴C]carbamoyl phosphate and [*ureido*-¹⁴C]citrulline) were incorporated to an insignificant extent.⁴³⁻⁴⁵

As cyanide production in fungi is widespread, Herbert proposed that this ion may be involved in the biosynthesis of the isonitrile group. Potassium [¹³C, ¹⁴C, ¹⁵N]cyanide and [¹⁴C, ¹³C, ¹⁵N]-2-hydroxy-4-methylvaleronitrile (which could either act as a 'protected' form of cyanide for safe delivery to the site of biosynthesis or as a representative of the metabolism of amino acids to cyanogenic glycosides often found in plants) were both satisfactory precursors for (3) but only the *O*-methyl group was labelled in each case. Methionine may be metabolised to ethylene and HCN, the latter being derived from C-2 of the amino acid. However, [2-¹⁴C]methionine also failed to label the isonitrile carbon. The conclusion of this series of studies is that cyanide is not the source of the isonitrile functionalities in the xanthocillins.^{44,45}

This group then addressed the issue of whether the origin of the nitrogen atoms in (3) was tyrosine. Nitrogen atoms in amino acids can be readily exchanged due to the action of transaminases making isotope labelling studies difficult. Comparison studies with (*DL*)-[¹⁵N]tyrosine, [¹⁵N]ammonium sulfate and (*L*)-[amido-¹⁵N]glutamine, however, showed that tyrosine was the preferred source for the nitrogen atoms,⁴⁵ a result which appears to be in agreement with similar studies using xanthocillin X (1).⁴⁶ It seems therefore, that the isonitrile functionalities in the xanthocillins are biosynthesised by attachment of an, as yet, unknown carbon atom to the nitrogen of tyrosine or a derivative. In view of the above evidence the atom must be part of a unit larger than a single carbon. Some indication of its biosynthetic origin has been obtained by feeding (*D*)-[U-¹³C, U-¹⁴C]glucose to *D. cejpii*.⁴⁴ Comparison of ¹³C enrichments in derivative (2) indicated that the isonitrile carbon is metabolically closer to glucose than either the PEP C₂ units, Figure 4, the C₄ unit in the aromatic ring or the *O*-methyl group as less dilution by endogenous intermediates implies a smaller number of steps. The precise origin of the isonitrile carbon in the xanthocillins, however, remains unresolved.

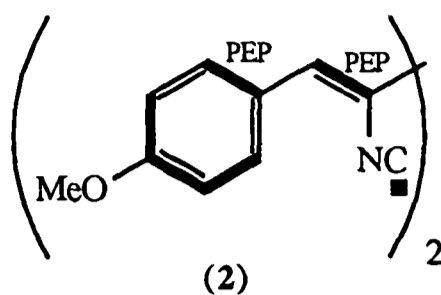
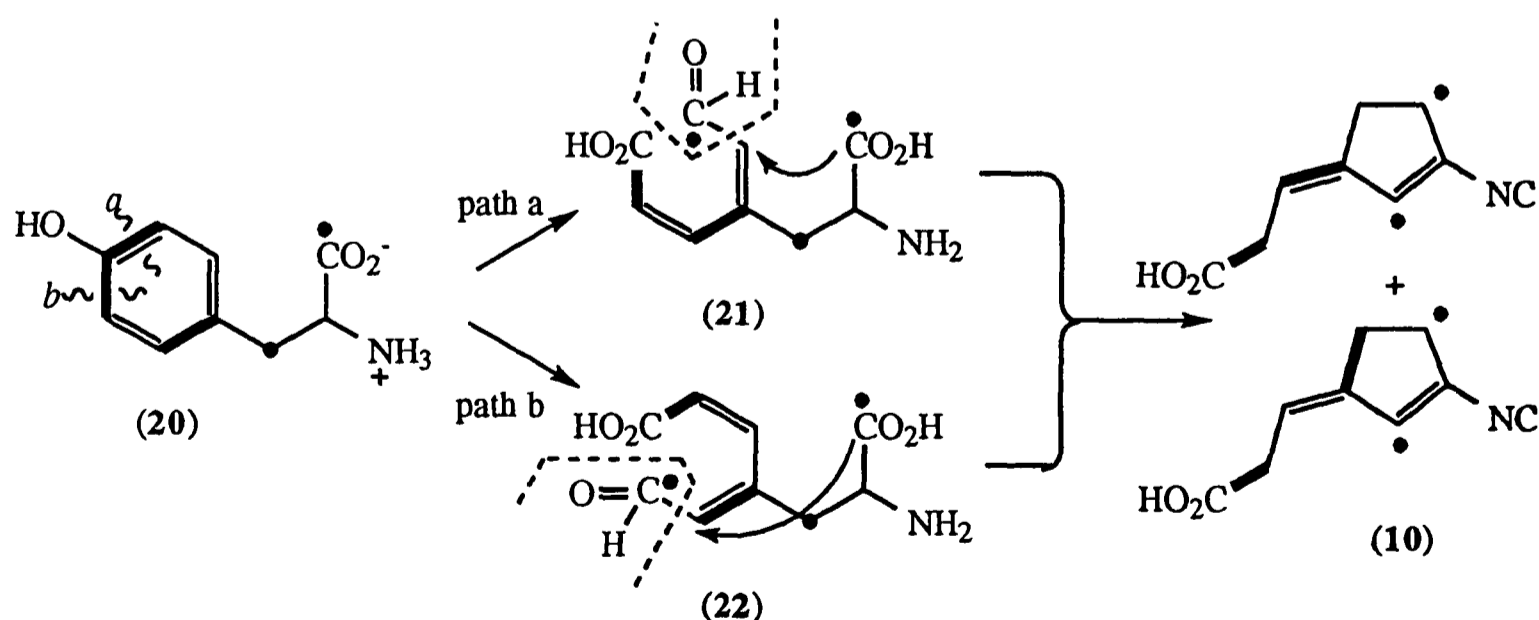

Figure 4

The amino acid derived biosynthetic origins of the cyclopentyl isonitriles derived from the *Trichoderma* moulds is less obvious. Feeding experiments carried out by Baldwin *et al.* have, however, indicated that isonitrile 270 (10) is elaborated from tyrosine (20),^{47,48} a result later confirmed by Parry using a different experimental design.⁴⁹ Ring fission of tyrosine (20) occurs at either of the equivalent bonds *a* or *b*, Scheme 1, and is followed by cyclisation of the tyrosine side chain. Whereas the enzymatic oxidative ring opening of tyrosine to a muconic acid semi-aldehyde is well known,⁵⁰ the subsequent cyclisation of the side chain appears to have no precedent. It is likely that the remaining cyclopentyl isonitriles share tyrosine as a common biogenetic precursor if one considers that they all derive from fungi of the same genus, all possess a C3 or C2 substituent at the 3-ring position and differ only in the degree of ring unsaturation and oxygenation.



Scheme 1

The origin of the isonitrile group in (10) was also investigated. Experiments using (*DL*)-[¹⁵N]tyrosine gave only an inconclusive 1% incorporation of ¹⁵N into the isonitrile

nitrogen (*c.f.* 4.5-7.5% incorporation of [¹⁴C]tyrosine). This result may be due to the rapid exchange of nitrogen with the amine pool, by the action of transaminases, but also raises the possibility of a nitrogen free intermediate in its biosynthetic pathway. In a similar fashion to the xanthocillin biosynthetic studies, *vide supra*, a large number of feeding experiments with C-1 precursors associated with tetrahydrofolate metabolism and potential cyanide sources were carried out but again the origin of the carbon atom could not be determined.⁵¹

The biosyntheses of neither A-32390A (18) nor brassicicolin A (19) have been studied but at a fundamental level they would both appear to be derived from valine (as the amino acid moiety) and (*D*)-mannitol.

1.2.2 Isonitriles from Marine Sponges and Nudibranches

Isolation

Fattorusso *et al.* isolated the first marine isonitrile metabolite from the sponge *Axinella cannabina* in 1973 which they named axisonitrile-1 (23).^{52,53} This discovery was somewhat surprising considering the chemical reactivity of the isonitrile group toward various nucleophiles and the medium (sea water) from which the organism was obtained. Since then, however, numerous other isonitrile containing metabolites have been obtained from marine sources making this, by far, the largest class of naturally occurring isonitriles.^{1,54,55} The most common sources are the sessile filter-feeding sponges of the orders Axinellida, Halichondrida and Haplosclerida. In addition, nudibranches (shell-less molluscs) of the genus *Phyllidia* often contain isonitriles which they utilise as defensive agents. It was shown that these isonitriles, which possess antimicrobial, cytotoxic and ichthyotoxic activities, derive from the sponges on which the nudibranch feeds.⁵⁶ 9-Isocyanopupukeanane (30), which was isolated from the Hawaiian nudibranch *Phyllidia varicosa* and in greater quantities from the sponge prey, *Ciocalypta* sp., was the first example of this class of compound.⁵⁷ More recently, cavernoisnitrile (24) was isolated from the sponge *Acanthella cf. cavernosa* and the nudibranch *Phyllidia ocellata*. Structure elucidation using spectroscopic techniques showed it to be the only known isonitrile of marine origin to possess the epoxy-isonitrile functionality, Figure 5.⁵⁸

So far all marine isonitriles isolated have been terpenoid, either sesqui- or diterpenes.^{1,54} The majority are the former with the molecular formula $C_{16}H_{25}N$. Often cyclic, these alkanes or alkenes possess only a single isonitrile group. A wide range of carbon skeletons are seen, Figure 5, including axane *e.g.* (23),⁵² (24),⁵⁸ eudesmane *e.g.* (25),⁵⁹ amorphane *e.g.* (26),⁵⁸ spiroxane *e.g.* (27),⁶⁰ aromadendrane *e.g.* (28),⁶¹ epimaaliane *e.g.* (29),⁶² pupukeanane *e.g.* (30)⁵⁷ and bisabolane *e.g.* (31).⁶³ Apart from the acyclic geranylalloyl isocyanide (32)^{64,65} the diterpenoids are often complex. The framework may be tri or tetracyclic and multiple functionalities are common. Their carbon skeletons are generally either of the amphilectene *e.g.* (33)⁶⁶ or kalihinol type *e.g.* (34).⁶⁷

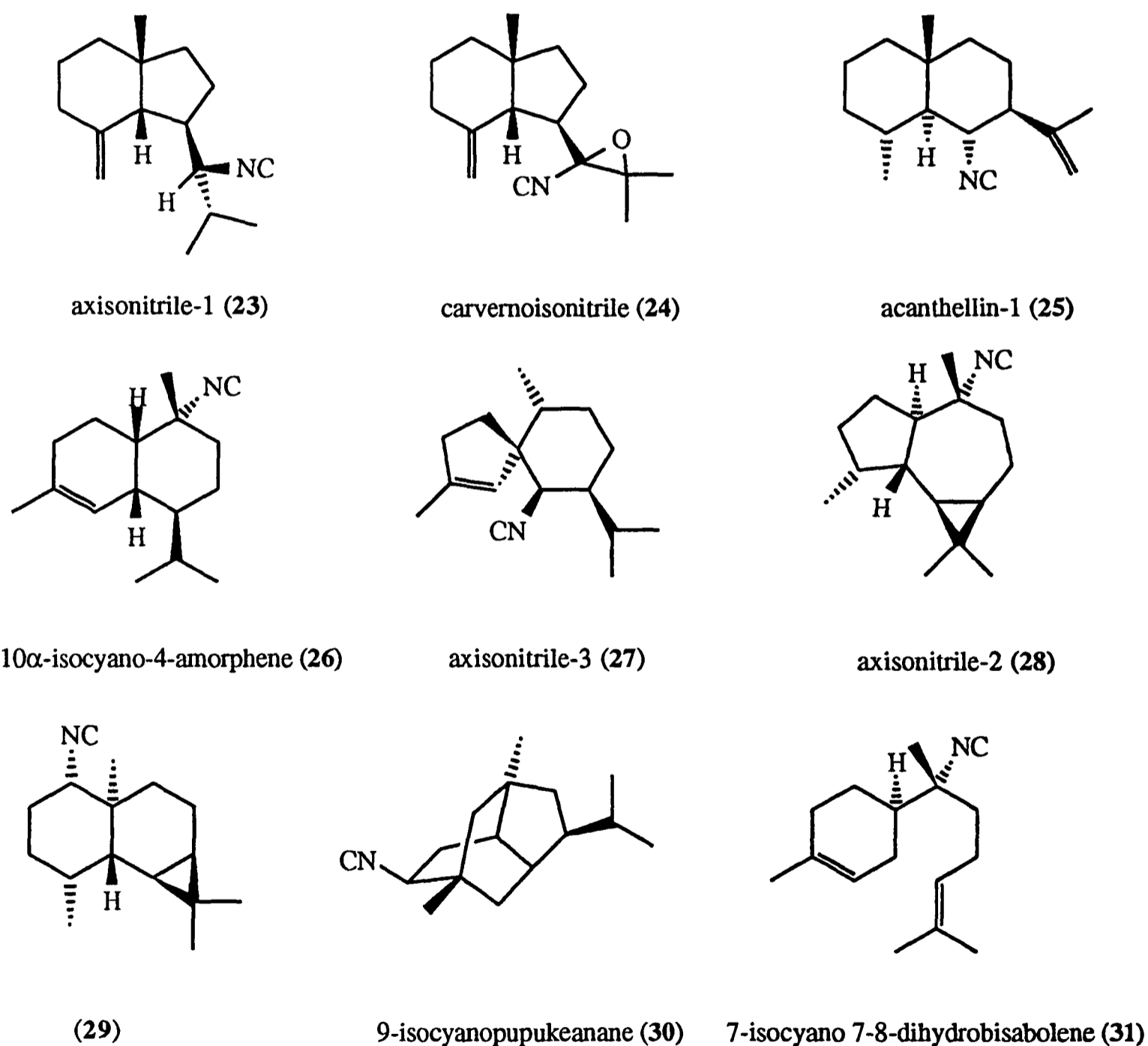

Figure 5

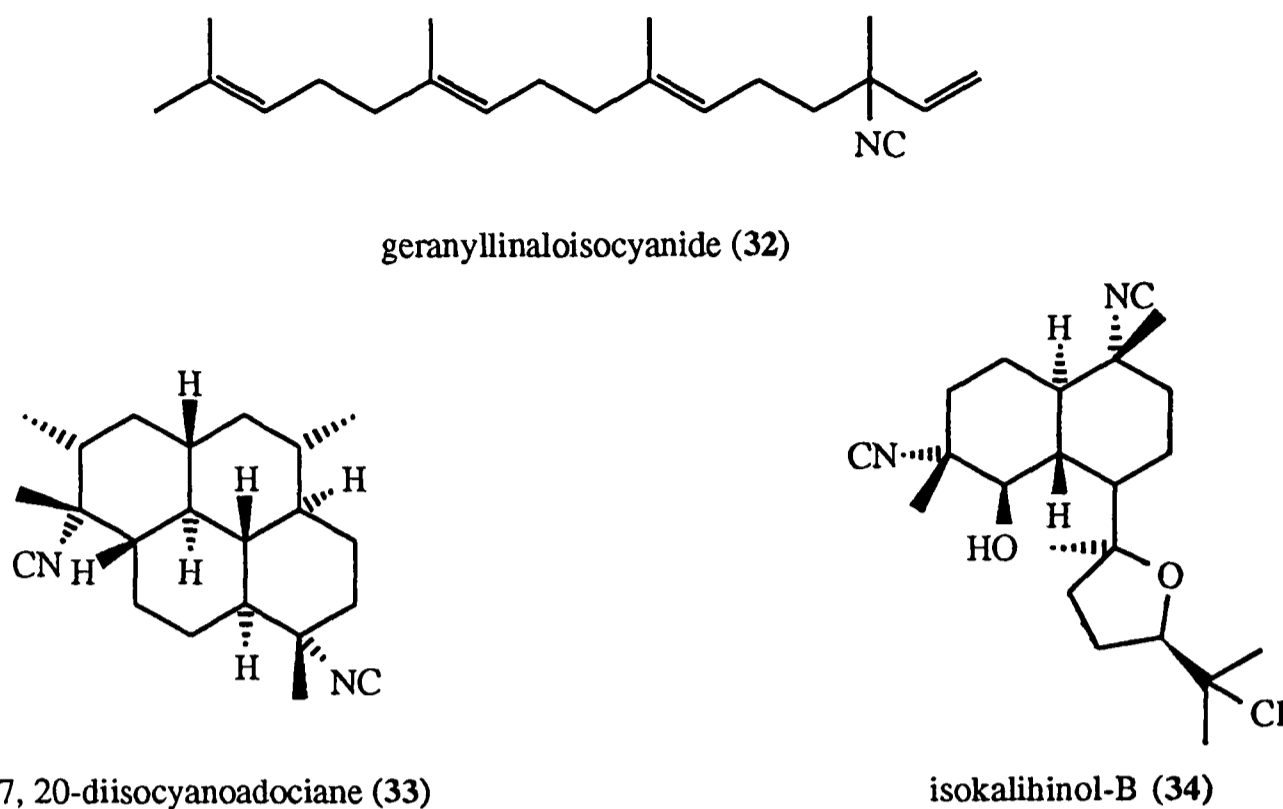

Figure 5 cont.

Many marine natural products have significant biomedical potential^{56,68,69} and the isonitrile metabolites are no exception. In addition to their well established chemical defence properties (*vide supra*), antiviral^{70,71} and antiparasitic⁷² activities have recently been reported.

Biosynthesis

Unlike other naturally occurring isonitriles, the marine metabolites are frequently found as triads with the corresponding isothiocyanate and formamide^{1,54} and it seems reasonable to conclude that there is some biosynthetic relationship between them. It would also appear reasonable to hypothesise that the isonitrile functionality is derived *in vivo* by dehydration of the *N*-formyl group. Evidence has been obtained by Iengo and Hagedone, however, to indicate that this does not occur and in fact it is the formamides and isothiocyanates that derive from the isonitriles.^{73,74}

On occasion, urea and amine derivatives have also been isolated and these compounds may also be related biosynthetically.⁵⁴ In addition, Wratten and Faulkner have reported the isolation of a number of carbonimidic dichlorides (or dichloroimines) *e.g.* (35) and (36), Figure 6, from the sponge *Pseudaxinyssa pitys*.⁷⁵⁻⁷⁷ The dichlorides exhibited no biological

activity although the corresponding isonitriles, prepared in the laboratory by LiAlH_4 reduction of the dichlorides, inhibited the growth of *Staphylococcus aureus*. The isonitriles were not found in the sponge but as *P. pitys* is capable of chlorination reactions it has been proposed that the dichlorides have resulted from enzymatic chlorination of the corresponding isonitriles. It has further been suggested that the chlorination results in an *in vivo* protection of the isonitrile which may be unmasked to give the biologically active compound when required. It is possible, however, that the dichloride arises from a Hofmann type reaction of a C_1 dichloride unit with an amine which then loses the chlorine atoms to deliver the isonitrile.

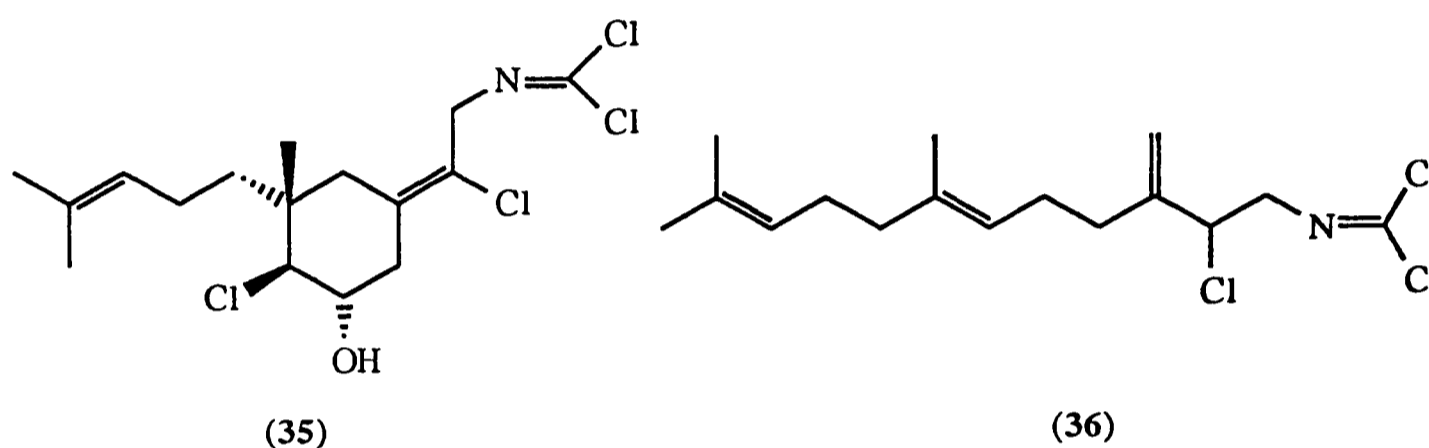

Figure 6

Biosynthetic attention has recently turned to the question of the origin of the isonitrile group in these metabolites.^{1,78,79} Considering that all the skeletons are terpenoid (and therefore biosynthesised from mevalonate) the nitrogen must be incorporated at some point from a pathway other than that which leads to the skeleton.

Herbert and Mann proposed that marine isonitriles might originate from the capture of the ambidentate cyanide ion⁴³ and this was later proved by Garson who observed incorporation of [^{14}C]cyanide into 7, 20-diisocyanoadociane (33) a metabolite from a marine sponge *Amphimedon* sp.^{80,81} The fact that cyanide is incorporated intact and not just the carbon was later demonstrated by Karuso and Scheuer who fed [^{13}C , ^{15}N]cyanide to the sponges *Ciocalypta* sp. and *Acanthella* sp. which produce the metabolites 9-isocyanopupukeanane (30) and kalihinol-F (52) respectively.⁷⁹ Moreover, cyanide incorporation appears to be enzyme-mediated and non reversible.⁸⁰⁻⁸²

It is proposed that cyanide is captured by a carbocation at some point during the biosynthesis. The majority of marine isonitriles bear the isonitrile groups on secondary

carbon atoms but some have these substituents on tertiary carbons or at primary allylic centres. The intermediacy of a carbocation is therefore attractive as the cyanide ion may realistically be accommodated on any of these sites. Biogenetic schemes have been proposed for a number of skeletal types. A possible path to the pupukeananes (30), (41) and (46) from an amorphane precursor, for example, is shown in Scheme 2.^{83,84}

Carbocationic intermediates in the metabolic pathway for the kalihinols, isokalihinols and kalihinene (a group of complex isonitriles isolated from *Acanthella* sp.⁸⁵) may explain the observed multiple functionality and stereoisomers. Kalihinene (49)⁶⁷ is *cis*-fused but may conceivably arise from a common precursor, a geranyl-geraniol equivalent. In contrast, isokalihinols bear hydroxy groups at C-5 and isonitrile groups at C-4 *e.g.* isokalihinol-B (49)⁸⁴ and isokalihinol-F (50),⁶⁷ instead of the more common 4-OH, 5-NC configuration as in kalihinol-A (50)⁸⁶ and kalihinol-F (51),⁸⁷ thereby inferring a common epoxy intermediate (48), Scheme 3.⁸²

1.3 Isonitriles from Prokaryotes

1.3.1 Isonitriles from Blue-green Algae (Cyanobacteria)

Isolation

The blue-green algae (cyanobacteria) show many structural features in common with bacteria including the absence of membrane bound organelles. They are classified with algae, however, because they contain chlorophyll *a* and are capable of oxygenic photosynthesis. A group of alkaloid isonitriles, the hapalindoles *e.g.* (54)-(59), has recently been isolated by Moore *et al.* from cultures of the terrestrial blue-green cyanophyte *Hapalosiphon fontinalis* and shown to be responsible for most of the antibacterial and antimycotic activity associated with this alga.^{88,89} More recently, related antifungal isonitriles, the hapalonamides *e.g.* (58) and (59),⁹⁰ the ambiguines *e.g.* (60)-(63),⁹¹ and fischerindole L (64),⁹² Figure 7, have been obtained from other members of the *Stigonemataceae*.

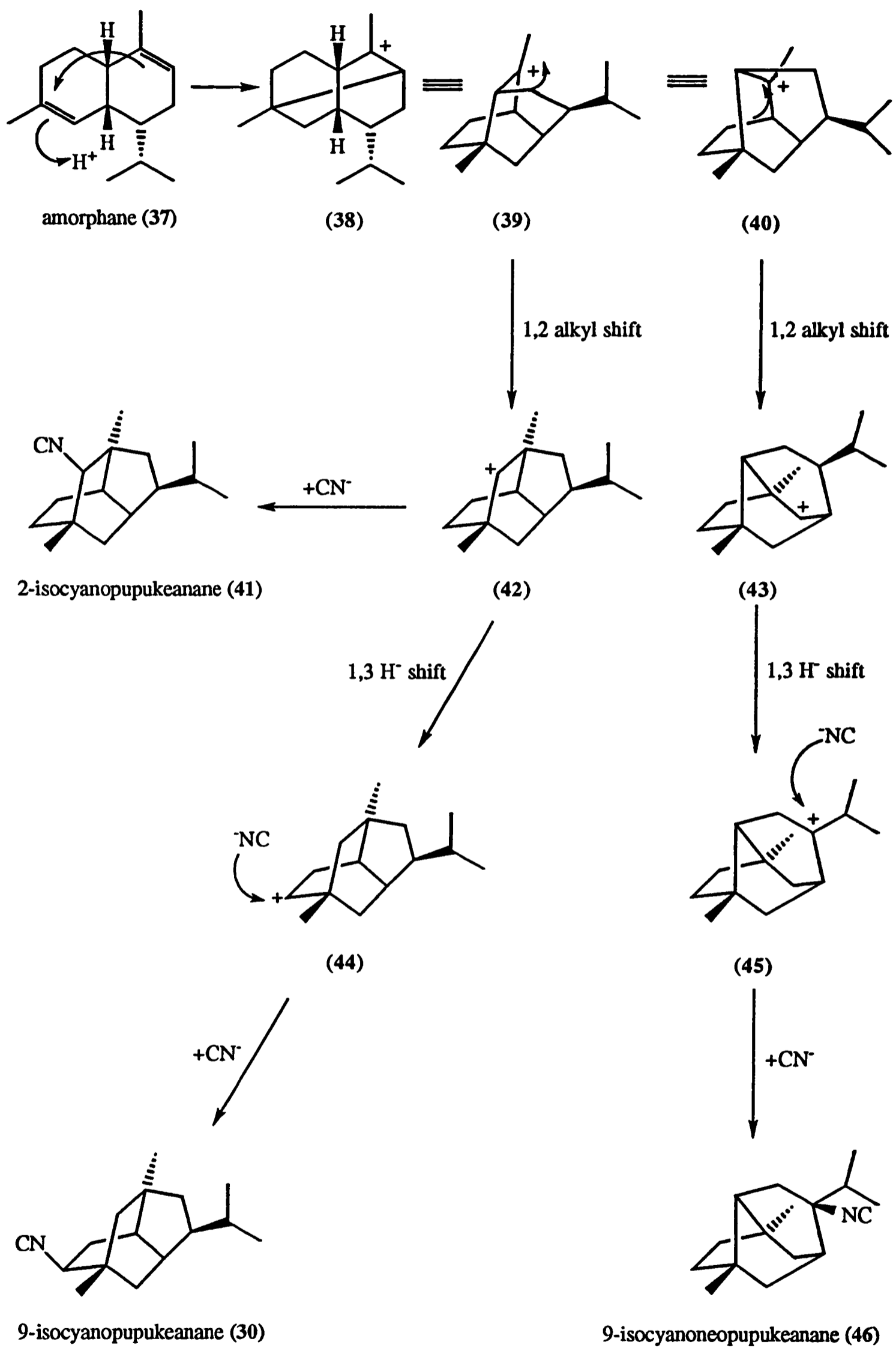

Scheme 2

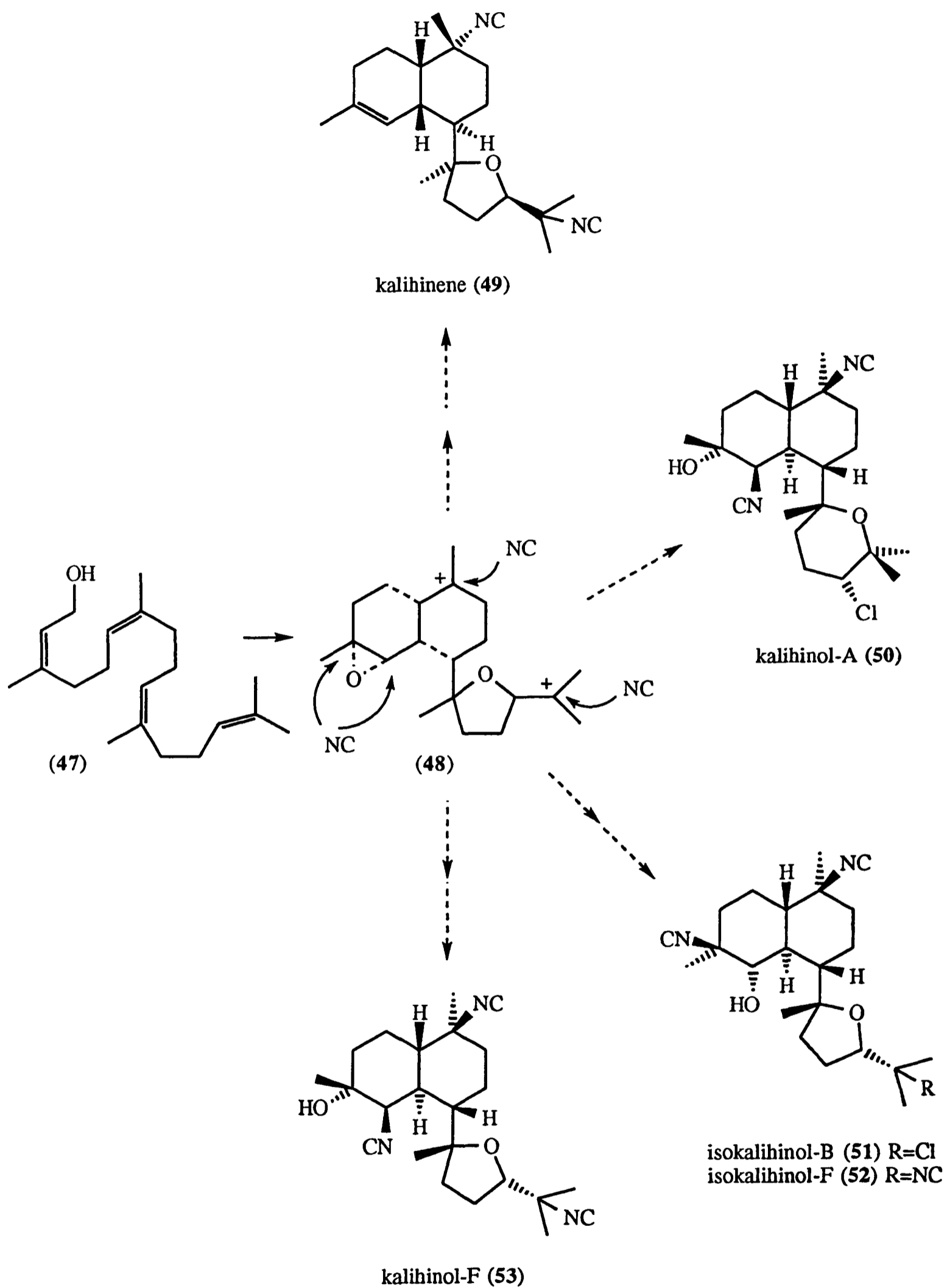

Scheme 3

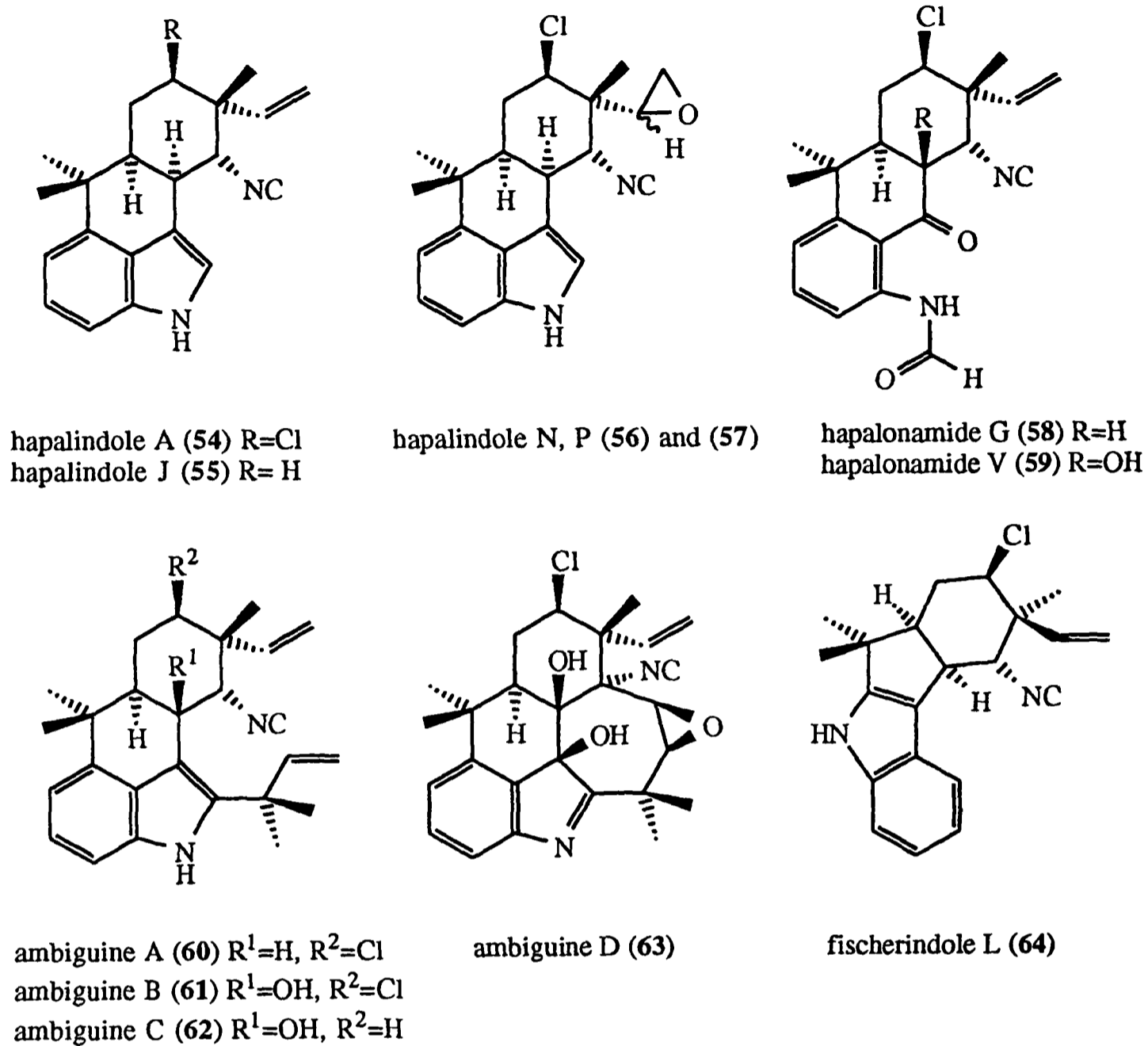

Figure 7

An aerial form of *Scytonema mirabile* produces the isotactic polymethoxy substituted mirabilene isonitriles, e.g. (65) and (66), which are mildly cytotoxic and antimicrobial,⁹³ Figure 8.

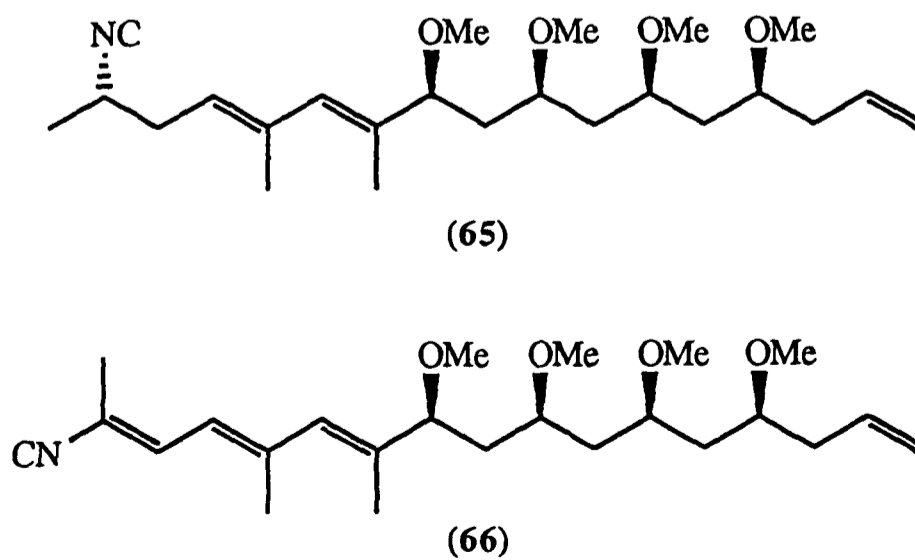

Figure 8

Biosynthesis

The hapalindoles, ambiguines and hapalonamides appear to be of mixed biosynthetic origin involving tryptophan and isoprene units. The biosynthesis of hapalindole A (54) has been investigated by Moore and co workers who showed that (*DL*)-[2-¹⁴C]tryptophan serves as a satisfactory precursor for the indole portion and also detected a low incorporation of acetate (although it was not confirmed whether the label was associated with the monoterpene unit).⁹⁴

Sources of glycine, serine, formate, and methionine which are associated with tetrahydrofolate metabolism were utilised for the synthesis of the isocyano functionality. Glycine and serine were incorporated more efficiently than methionine or formate. Experiments with [2-¹³C, ¹⁵N]glycine moreover proved that both atoms are utilised for biosynthesis of the isonitrile group. In addition ¹⁴C labelled cyanide proved to be an excellent and specific precursor for this group. As cyanobacteria are capable of the metabolism of amino acids into free cyanide^{95,96} these results can best be explained by the direct bioconversion of glycine into cyanide without intervention, in this case, of metabolism centred on tetrahydrofolate.

No biosynthetic studies have been carried out on the mirabilenes but it would seem reasonable to propose that the carbon frameworks are acetate derived with alkylations by *S*-adenosylmethionine (SAM) presumably providing the additional methyl groups.⁹⁷

1.3.2 Isonitriles from Bacteria

1.3.2.1 Isonitriles from Actinomycetes

Isolation

Three isonitriles have been isolated from actinomycete bacteria. The isomeric, biphenolic hazimycin factors 5 (67) and 6 (68) were obtained from *Micromonospora echinospora* var. *challisensis*.^{98,99} They are broad spectrum antibiotics that are interconvertible in the presence of water. Indisocin (69)¹⁰⁰ is an unstable antibiotic obtained from *Nocardia blackwellii*, Figure 9.

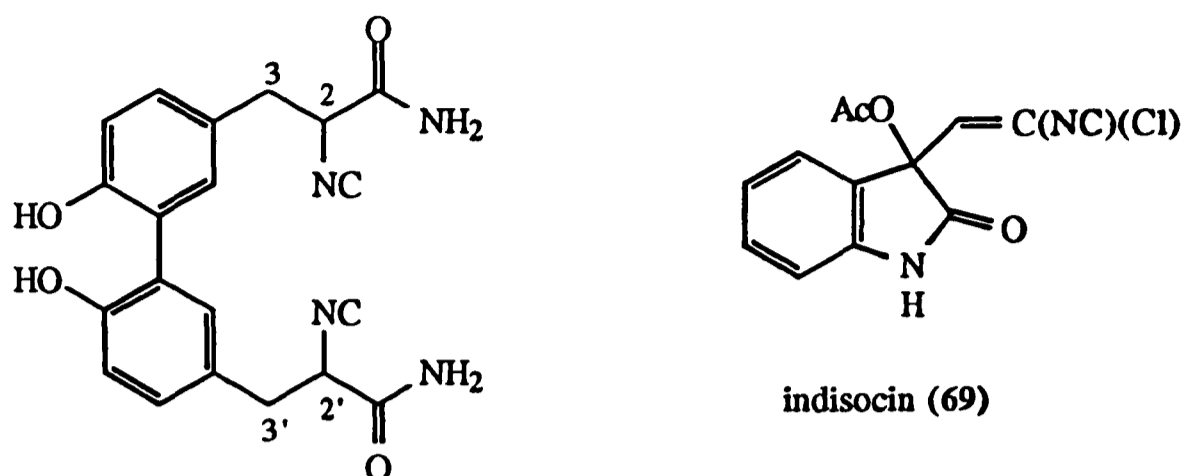

hazimycin factor 5 (67) (2R, 2'R) and (2S, 2'S)
hazimycin 6 (68) (2R, 2'S)

Figure 9

Biosynthesis

The actinomycetes are an unusual group of Gram-positive bacteria. Their prokaryotic cellular organisation, the chemistry of their cell walls, their nitrogen metabolism and their sensitivity to antibiotics and phages, more specifically termed actinophages, leaves little doubt that they are bacteria but for a long time their capacity for mycelial growth caused speculation as to whether their phylogenetic affinities actually lay with the fungi. In common with the fungal isonitriles, the hazimycin factors (67) and (68) derive from amino acid metabolism. (*DL*)-[2-¹³C]Tyrosine was incorporated into (67) and (68) in cultures of *Micromonospora echinospora* var. *challisensis* with the label being found at C-3' and C-3, Figure 9.¹⁰¹ In addition [methyl-¹³C]methionine could be incorporated, a result which contrasts with those obtained for the xanthocillins from fungi, *vide supra*. ¹³C analysis indicated that the isonitrile groups were labelled. This implied that *N*-methyltyrosine should be a biosynthetic intermediate but, somewhat surprisingly, no label from *N*-[¹³C]methyl-(*DL*)-tyrosine was incorporated thereby casting some doubt on the validity of the result with methionine.⁴⁴ The biosynthesis of indisocin (69) has not been studied, but structural similarities to the amino acid tryptophan are apparent, *vide infra*.

1.3.2.2 Isonitriles from Other Bacterial Types

Isolation

Two isonitrile containing metabolites have been obtained from other types of bacteria. Aerocyanidin¹⁰² (70) was isolated from cultures of *Chromobacterium violaceum* along with the unrelated macrolide aerocavin¹⁰³ and shown to be active primarily against Gram positive bacteria. The structure of aerocyanidin (70) was determined by spectroscopic characterisation of the antibiotic and of the degradation product (72) which results from treatment of (70) with base, Scheme 4. Aerocyanidin was thus determined to be an epoxy-isonitrile resembling trichoviridin in possessing a hydroxyl group adjacent to the epoxide with the same relative stereochemistry.

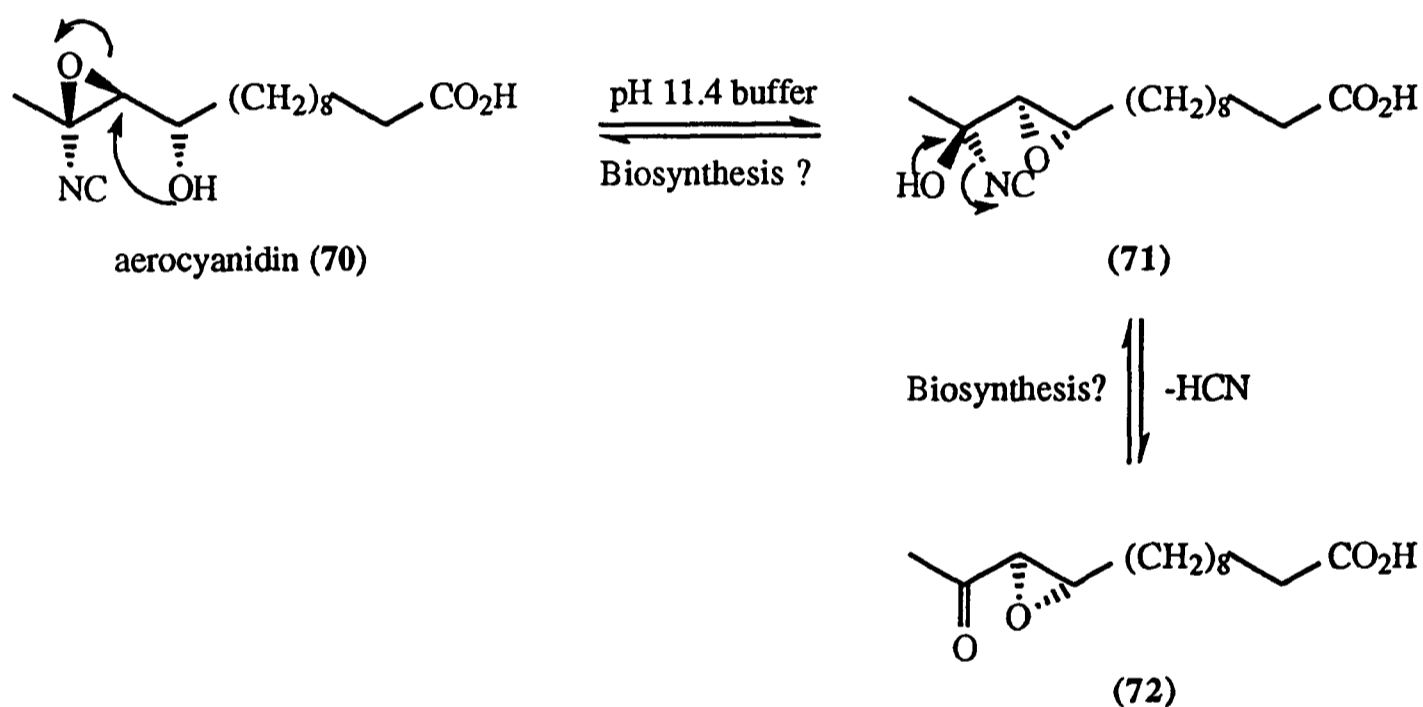

Scheme 4

The unstable metabolite indoleacryloisonitrile (73)^{104,105} was obtained from *Pseudomonas* NCIB 11237, Figure 10 and shown to exhibit potent antimicrobial and antifungal activity.

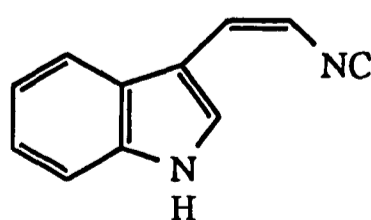

indoleacryloisonitrile (73)

Figure 10

Biosynthesis

The biosynthetic origins of these metabolites have not been studied but the carbon framework of aerocyanidin (70) appears to be derived from acetate and the indole portion of (73) is likely to be derived from the amino acid tryptophan. This leaves unanswered the question of the origin of the isonitrile functionalities in these metabolites. *Chromobacterium violaceum* and *Pseudomonas* sp. are unusual among bacterial species in that they have in common with cyanobacteria the ability to metabolise the amino acid glycine into cyanide (and *vice versa*).^{95,96,106,107} Thus, it is plausible that cyanide is the precursor of the isonitrile functionalities in (70) and (73). A possible biosynthetic pathway for aerocyanidin involves the formation of cyanohydrin (71) followed by a Payne reaction *i.e.* the reverse of the base catalysed degradation, Scheme 4.

1.4 Conclusion on the Biosynthesis of Isonitriles

The body of evidence suggests that the nitrogen of the isonitrile groups in the fungal and actinomycete metabolites are amino acid derived whereas, with the possible exception of the hazimycin factors (67) and (68), the origin of the carbon atom remains unresolved. The remaining microbial isonitriles are produced by species that have adapted and developed cyanide resistant respiratory systems to enable them to survive in the presence of cyanide and it is presumably this ion that forms the isonitrile moieties in these metabolites.^{95,96,106,107}

The isonitrile groups of the marine metabolites also derive from cyanide but the production of cyanide in sponges is not proven and sequestration of cyanide from sea water seems unlikely.⁸¹ The *de novo* synthesis of terpenes from acetate in sponges is also yet to be established.¹⁰⁸ It is well known, however, that marine sponges often contain microorganisms including cyanobacteria and those of the genera *Chromobacterium* and *Pseudomonas*.¹⁰⁹ As these bacteria can produce inorganic cyanide and are capable of acetate metabolism it has been speculated that they are playing a symbiotic rôle in the biosynthesis of the sponge metabolites.⁸⁰ This theory is currently under active investigation in a number of research groups.^{83,80}

Chapter 2

The Synthesis of Isonitriles

2.1 Introduction

The first synthesis of an isonitrile is attributed to Lieke who, in 1859, reacted allyl iodide with silver cyanide and obtained a vile smelling liquid distinctly different to the expected allyl cyanide.¹¹⁰ The result was explained several years later by Hofmann¹¹¹ and Gautier¹¹² who realised that isonitriles were a novel class of compounds, isomeric to nitriles.

Recent advances have allowed the effective preparation of isonitriles and their increased availability has led to the exploitation of their chemistry. Synthetic applications include α -addition reactions,¹¹³⁻¹¹⁵ multi-component condensations,^{116,117} peptide synthesis,¹¹⁸ co-ordination chemistry,¹¹⁹⁻¹²¹ organometallic reactions,¹²² radical chemistry^{123,124} and carbohydrate chemistry.¹²⁵ In addition, naturally occurring isonitriles and their analogues have been targeted by synthetic chemists because of their interesting structures and often potent biological activity.

The methods available for the preparation of isonitriles were well documented some time ago.¹²⁶⁻¹²⁸ The following survey on the synthesis of this fascinating group will, therefore, emphasise the more recent literature. Examples of the use of the various methods in the synthesis of the natural products will be included as relevant.

2.2 Isonitrile Synthesis by Dehydration of Formamides

Any synthetic strategy for an isonitrile must take into account the acid lability and the facile oxidation of this functionality.¹²⁸ For this reason dehydration of the corresponding formamide at a late stage of a synthesis is considered to be one of the most reliable methods

of preparing this sensitive group, Scheme 5. Consequently the precursor formamide (74) becomes the key synthetic target.

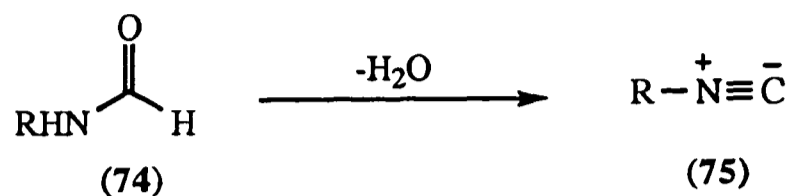

Scheme 5

A wide variety of dehydrating agents including phosgene, diphosgene, *p*-toluenesulfonyl chloride and phosphorous oxychloride will effect the dehydration of formamides in the presence of base.^{127,128} Chlorodimethylformiminium chloride (76) (the Vilsmeier reagent), 2-chloro-3-ethylbenzoxazolium tetrafluoroborate (77) and oxomethylene(3H⁺-imidazolium *bis*(methanesulfonate)) (78), which require generation *in situ*, have also been utilised in this rôle.^{127,129}

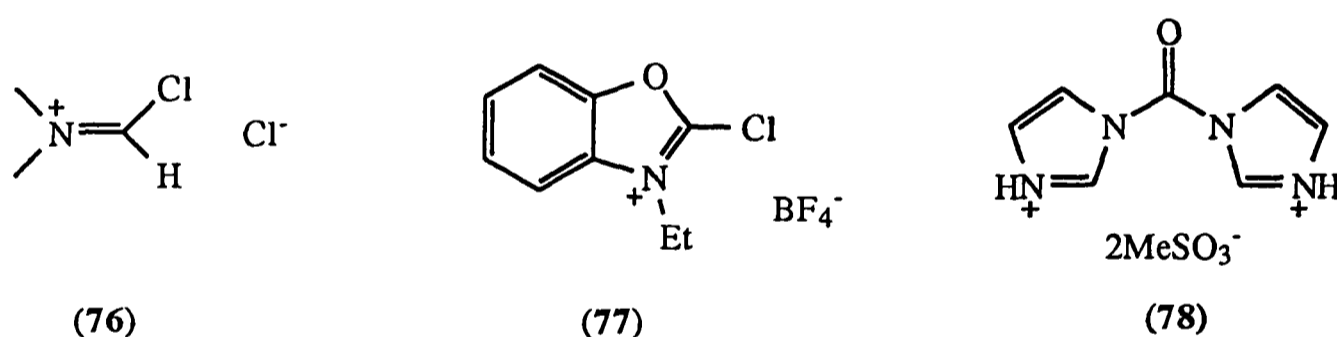
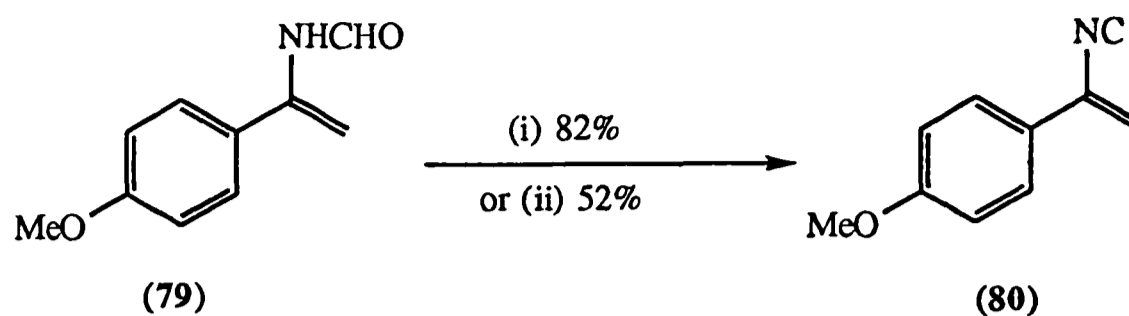

Figure 11

Yields are variable with most of these dehydration conditions being intolerant of functional groups such as epoxides making the preparation of more sensitive isonitriles difficult. Furthermore, these reagents are not as reactive as might be expected, with prolonged reaction times and elevated temperatures often being required to effect complete dehydration. Baldwin and co-workers^{130,131} have recently demonstrated that rapid dehydration of formamides can be achieved in good yield by the use of the highly reactive trifluoromethanesulfonic (triflic) anhydride reagent,¹²⁹ Scheme 6. A proposed mechanism for the dehydration is outlined in Scheme 7.



(i) Tf_2O , $i\text{Pr}_2\text{EtN}$, -78°C ; (ii) COCl_2 , DABCO, 0°C .

Scheme 6

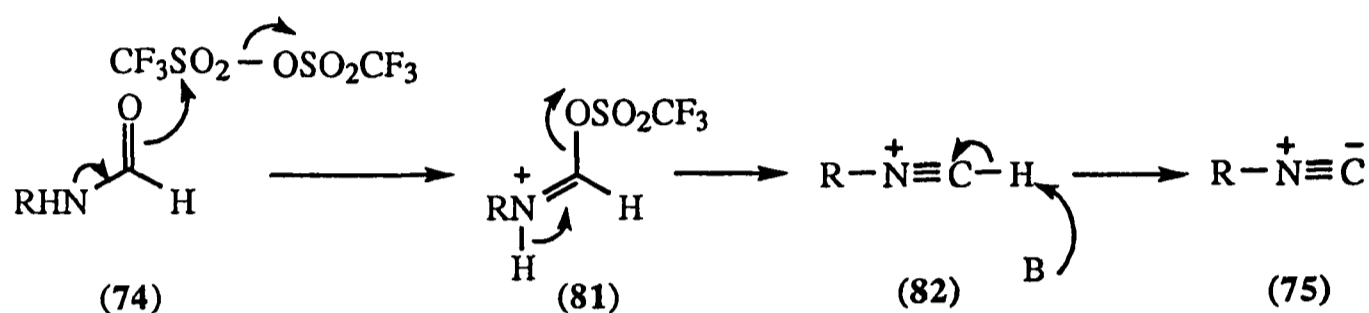

Scheme 7

The use of this reagent circumvents the problem of generating a reactive nucleofuge *in situ* and the general applicability of the reagent to sensitive systems has been amply demonstrated by the successful conversion of the highly functionalised formamide (83) to (84). This is a substrate for which a number of the aforementioned reagents gave none of the desired product, Scheme 8.¹³¹

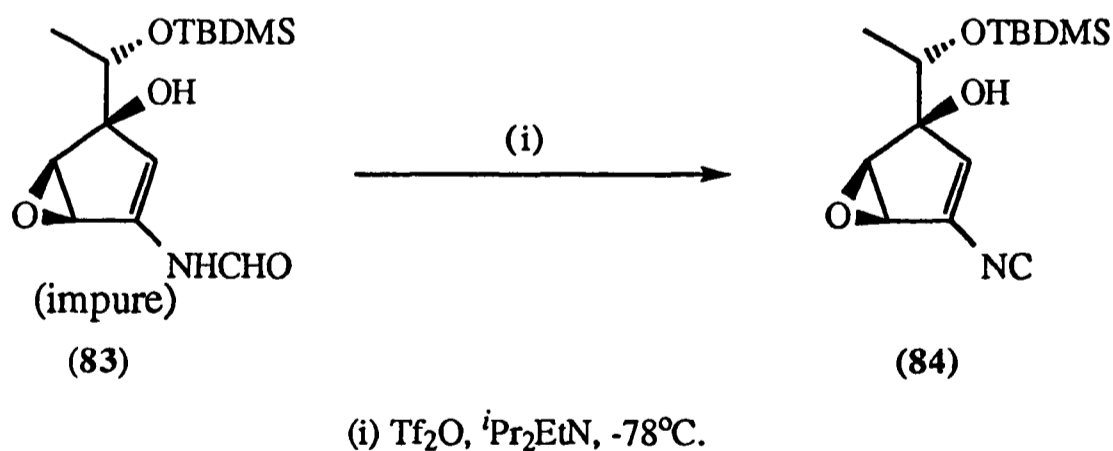

Scheme 8

2.2.1 The Synthesis of Isonitriles Attached to a Saturated Carbon

The saturated isonitrile functionality is commonly observed in the marine sponge and algal metabolites. A number of these have been synthesised *via* dehydration of the corresponding formamide generally prepared by formylation of the corresponding amine. As a variety of ways exist for the introduction of the amine group, the main challenge in the

synthesis of these particular metabolites is often the construction of the carbon framework, as illustrated by the following two examples. Stereocontrolled synthesis of the algal metabolite hapalindole G (**96**)⁸⁸ from (**85**) (available from (-)-carvone¹³²) has been reported by Fukuyama and Chen.¹³³ A key feature of the synthesis was the stereospecific introduction of chlorine into the hindered C-13 position. The *neo*-pentyl isonitrile functionality was assembled by formation of azide (**94**) from the corresponding mesylate, reduction using sodium amalgam in methanol, formylation and finally dehydration with phosgene in the presence of triethylamine, Scheme 9.

(-)-8,15-Diisocyano-11(20)-amphilectene isolated from the sponge *Hymeniacidon amphilecta*,¹³⁴ was shown by X-ray diffraction analysis to have the structure and relative stereochemistry shown in (**114**). Piers *et al.* have recently completed a synthesis of racemic (**114**) in nineteen steps from (**97**), Scheme 10.^{135,136} Construction of the carbon framework was achieved by utilising the Diels-Alder reaction of (**98**) with acrolein to afford aldehyde (**102**) and subsequent elaboration of its side chain to generate diacid (**109**). Completion of the synthesis was achieved by transformation of the carboxyl groups to isonitriles. Compound (**109**) was converted to the dicarbamate (**111**) using diphenyl phosphorazidate and triethylamine followed by reaction of the resultant isocyanate with 2-(trimethylsilyl)ethanol in the presence of triethylamine. Addition of TBAF to (**111**) generated diamine (**112**) which was formylated to give the corresponding diformamide (**113**). Dehydration was effected using triphenylphosphine-carbon tetrachloride in the presence of triethylamine. A similar strategy was adopted by this group to introduce the isonitrile functionality in a total synthesis of another amphilectene-type diterpenoid, (±)-8-isocyano-10,14-amphilectadiene.¹³⁷

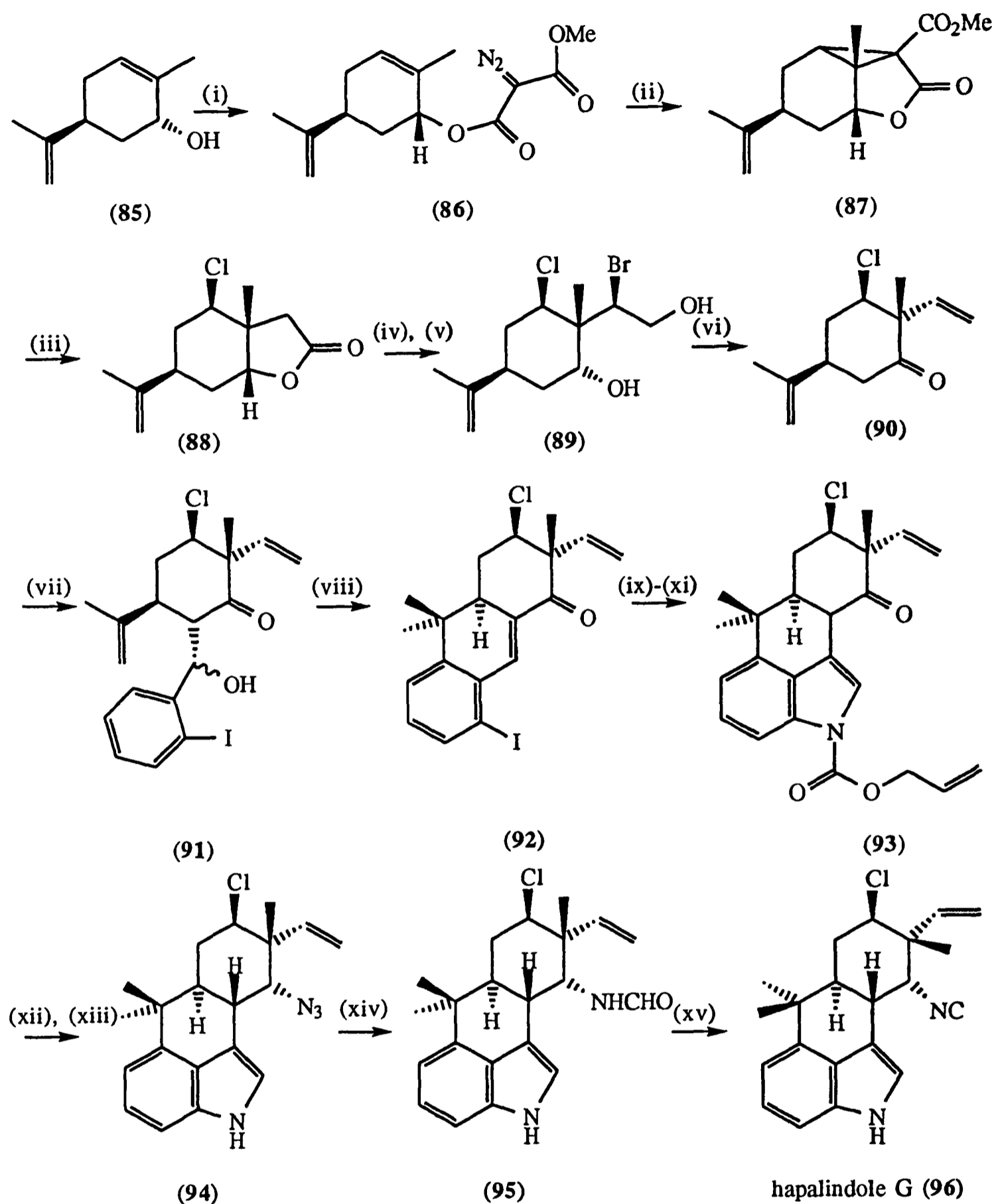

(i) $\text{MeO}_2\text{CCH}_2\text{COCl}$, Et_3N , DCM, -30°C , 97% then $p\text{-AcNHC}_6\text{H}_4\text{SO}_2\text{N}_3$, DBU, CH_3CN , 23°C , 98%; (ii) Copper (II) *bis*(salicylidene-*t*-butylamine), DCM, 70°C , 8h., 60%; (iii) LiCl, CSA, DMF, 140°C , 71%; (iv) LDA, -78°C , THF then CBr_4 , -78°C to 23°C , 81%; (v) DIBAL, -78°C , DCM then EtOH, NaBH_4 , 23°C , 71%; (vi) Zn-Cu couple, EtOH, reflux, 95% then Jones reagent, 23°C , 99%; (vii) LDA, -78°C , THF, $(^i\text{PrO})_4\text{Ti}$ then $o\text{-IC}_6\text{H}_4\text{CHO}$, 68%; (viii) Ac_2O , pyridine, 60°C then DBU, C_6H_6 , reflux then TFA- $\text{CH}_3\text{SO}_3\text{H}$ (10:1), 23°C , 88%; (ix) $\text{Pd}(\text{OAc})_2$, Ph_3P , Et_3N , CO (1 atm.), $\text{CH}_3\text{CN}:\text{H}_2\text{O}$ (8:1), 80°C , 80%; (x) DPPA, Et_3N , allyl alcohol, toluene, 110°C , 90%; (xi) $\text{LiCH}_2\text{SMe}(\text{SOMe})$, -78°C , THF, then H_2O , HgCl_2 , HClO_4 , 80°C , 69%; (xii) NaBH_4 , MeOH, 23°C , 91%; (xiii) Ms_2O , pyridine, 65°C , 82%; (xiv) LiN_3 , 2% H_2O -DMF, 100°C , 36h., 96%; (xv) Na/Hg , EtOH, reflux, HCO_2H , Ac_2O , pyridine, DCM, 23°C , 84%; (xvi) COCl_2 , Et_3N , DCM, 0°C , 90%.

Scheme 9

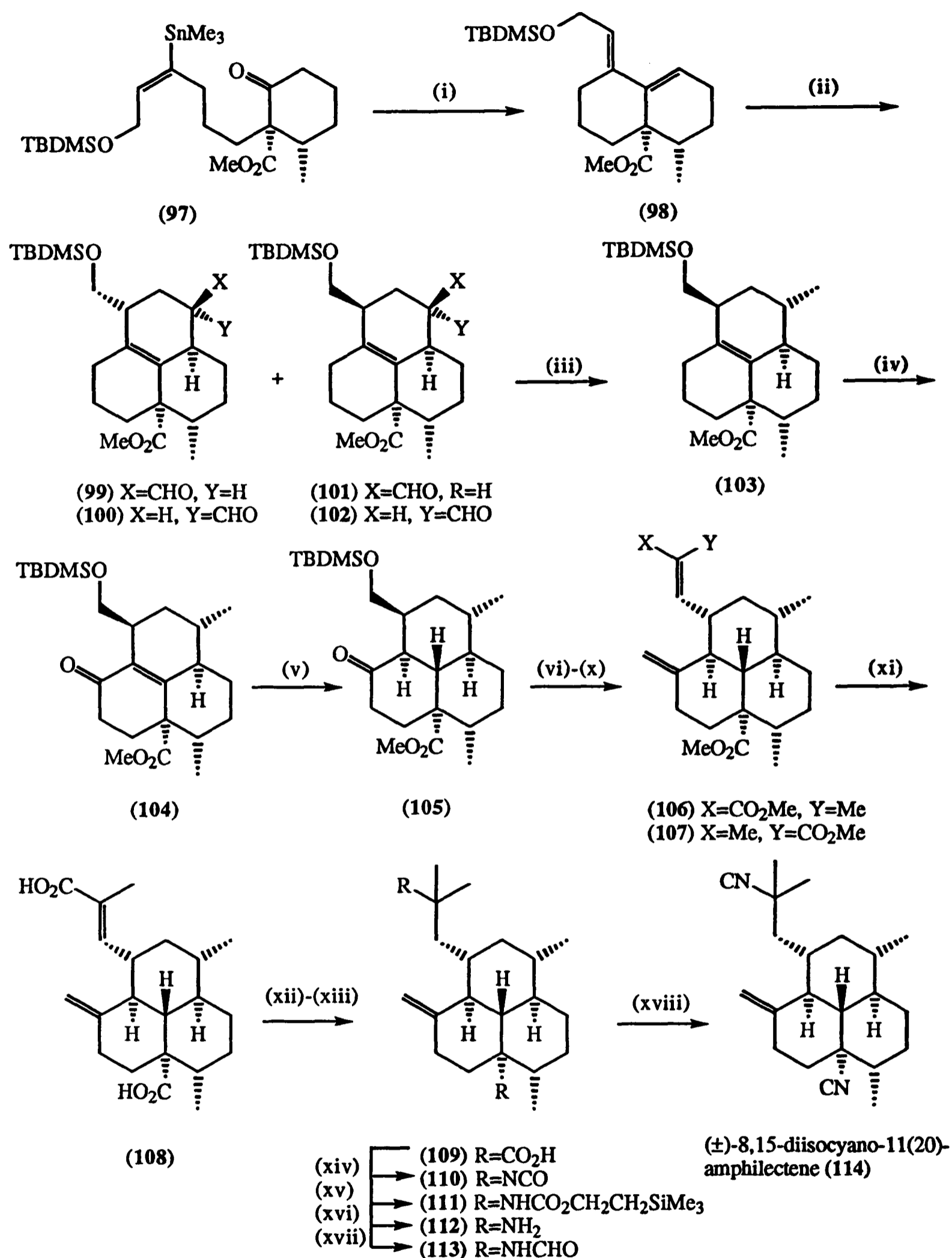

(i) LDA then PhNTf₂ then (Ph₃P)₄Pd, 86%; (ii) acrolein, PhH, reflux; NaOMe, MeOH, 58%;
 (iii) NaBH₄ then *p*-TsCl then LiEt₃BH, 87%; (iv) CrO₃, 77%; (v) Na, ^tBuOH, NH₃, Et₂O, 86%;
 (vi) CH₂Br₂, Zn, TiCl₄, DCM, 79%; (vii) ⁿBu₄NF, 86%; (viii) (COCl)₂, DMSO, Et₃N, 87%;
 (ix) NaOMe, MeOH, 95%; (x) [(MeO)₂P(O)C(Me)CO₂Me]K, 96%; (xi) PhSeNa, THF, HPMA, 88%;
 (xii) Li, NH₃, 50%; (xiii) LDA, MeI, 55%; (xiv) (PhO)₂P(O)N₃; (xv) Me₃SiCH₂CH₂OH;
 (xvi) ⁿBu₄NF; (xvii) AcOCHO; (xviii) PPh₃, CCl₄, 41% from (109).

Scheme 10

The following two examples are total syntheses of less complex marine metabolites. They illustrate, however, some interesting solutions to the introduction of the formamide group. During isolation studies with the Okinawan sponge *Theonella cf. swinhoei*, 3-isocyanotheonellin (120) was not detected despite the corresponding formamide and isothiocyanate being present.¹³⁸ Subsequently, however, Scheuer's group found it to be the major metabolite in a *Phyllidia* sp. nudibranch, from Sri Lanka.⁶³ A biomimetic synthesis of (120) was reported in 1991.^{139,140} Ichikawa achieved direct amination of the theonelline carbon framework by employing the triflic acid promoted Ritter reaction at low temperature generating a mixture of stereoisomers. The allyl sulfone isomer (117) was converted to (118) through a Julia *trans* olefination. The acetamido compound (118) was treated with triethyloxonium tetrafluoroborate followed by hydrolysis with acetic acid to afford an amine, formylation of which, with acetic formic anhydride, provided (119). Formamide (119) was then converted to (120) using triflic anhydride in *N,N*-diisopropylethylamine at -78°C , Scheme 11.

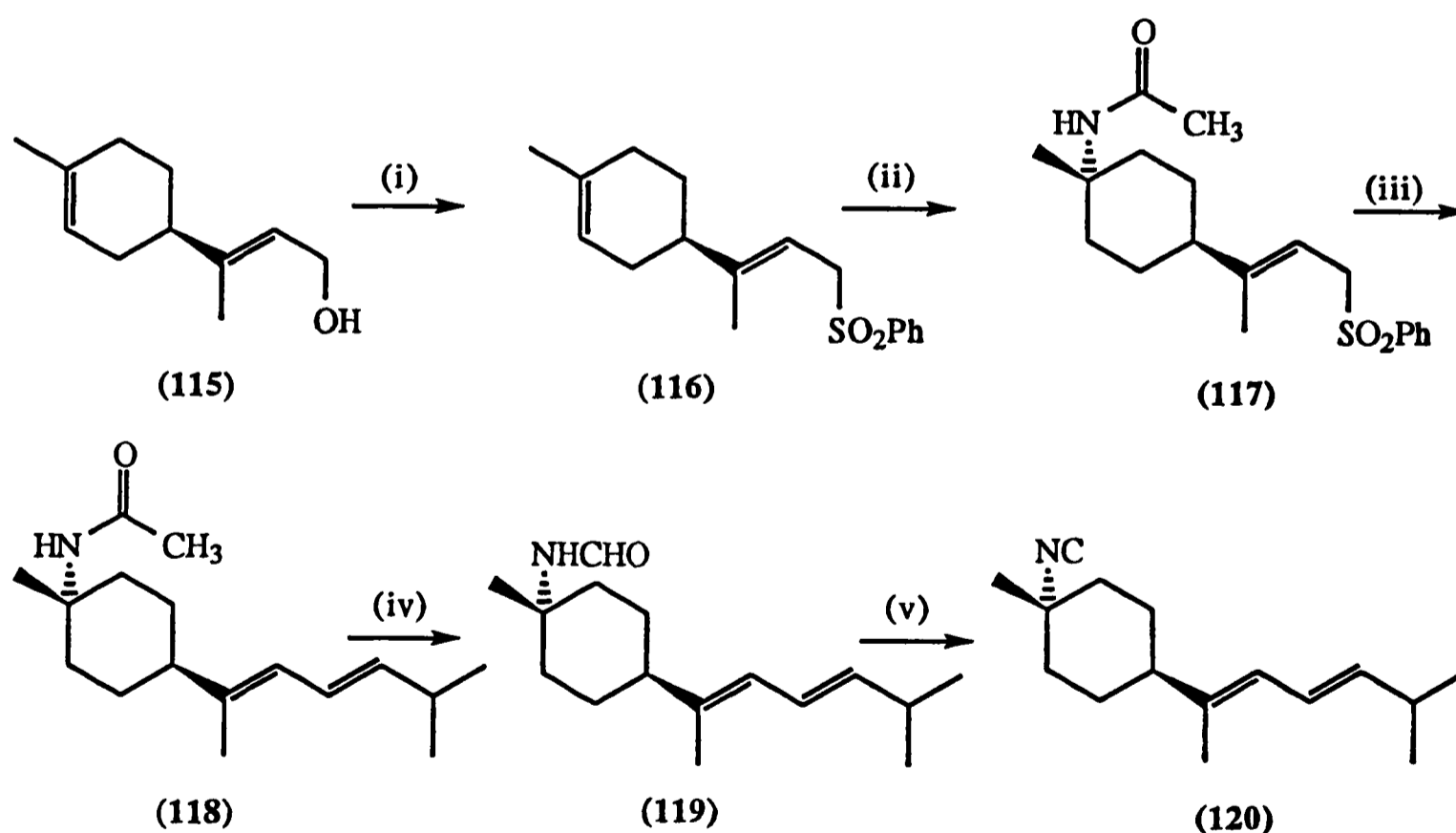

(i) PBr_3 then PhSO_2Na , 78%; (ii) $\text{CF}_3\text{SO}_3\text{H}$, CH_3CN , -78°C then aq. NaHCO_3 , 50%, (minor isomer 48%); (iii) $n\text{BuLi}$, isobutyraldehyde then Ac_2O , pyridine then Na/Hg , Na_2HPO_4 , 98%; (iv) Et_3OBF_4 , Na_2CO_3 then AcOH , H_2O , THF then AcOCHO , 88%; (v) Tf_2O , $i\text{Pr}_2\text{EtN}$, -78°C , 89%.

Scheme 11

The diterpene isonitrile, geranylinaloisocyanide (**32**) was isolated along with the formamide (**126**) and the corresponding isothiocyanate from a sponge of the species *Halichondria*.^{64,65} Recently (**32**) was synthesised from geranylgeraniol *via* an allyl cyanate to isocyanate rearrangement.¹⁴¹ The cyanate (**123**) was prepared by dehydration of the precursor allyl carbamate (**122**). Treatment of (**123**) with Me_3Al then generated the acetamide (**125**) *via* the unstable isocyanate (**124**). The acetamide (**125**) was transformed to the corresponding amine with Meerwein's salt. Treatment of this amine with acetic formic anhydride generated formamide (**126**). Dehydration was in this case effected by using triphenylphosphine, CBr_4 and diisopropylethylamine, Scheme 12.

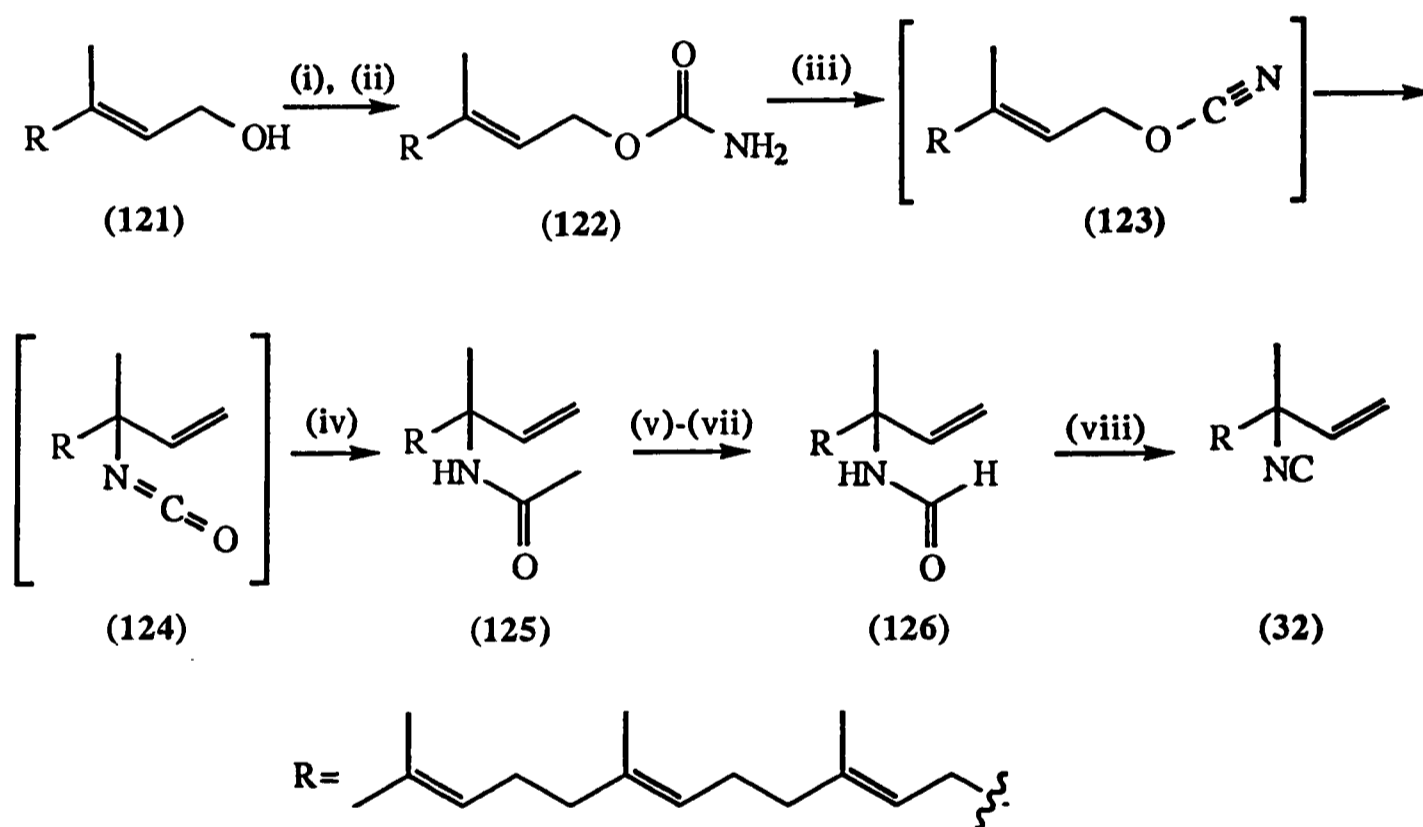

(i) CCl_3CONCO ; (ii) K_2CO_3 , aq. MeOH; (iii) Tf_2O , $i\text{Pr}_2\text{EtN}$;
 (iv) Me_3Al , 59% from (**121**); (v) Meerwein's salt; (vi) AcOH , aq. THF;
 (vii) AcOCHO , 84%; (viii) PPh_3 , CBr_4 , $i\text{Pr}_2\text{EtN}$, -20°C , 82%.

Scheme 12

Other syntheses of naturally occurring saturated isonitriles in which the isonitrile was prepared by dehydration of the corresponding formamide include those of axisonitrile-1 (**23**),^{142,143} axisonitrile 3 (**27**),¹⁴⁴ hapalindole J (**55**),¹⁴⁵ 2-isocyanopupukeanane (**41**)¹⁴⁶ and 9-isocyanopupukeanane (**30**).^{147,148}

2.2.2 Vinyl Isonitrile Synthesis

The vinyl isonitrile is a particularly prevalent functionality amongst fungal and bacterial metabolites. The preparation of this group is not as straightforward as for the saturated isonitriles (*vide supra*) due to the greater difficulty in generating the precursor vinyl formamide. The following methods for the preparation of the latter have, however, been developed.

In 1988 Barton¹⁴⁹ published a synthesis of vinyl formamides based upon the reduction of ketoximes *e.g.* (127) to the corresponding imine¹⁵⁰ by treatment with titanium (III) acetate followed by *in situ* formylation with acetic formic anhydride, Scheme 13. A possible drawback of this method is the high Lewis acidity of titanium (III) acetate which raises the problem of functional group compatibility.

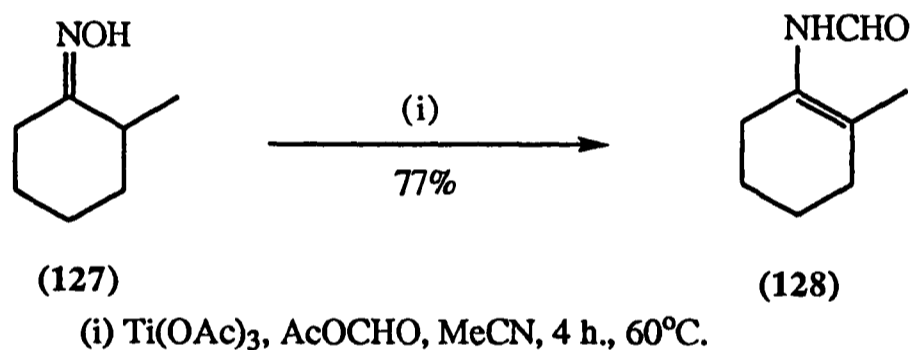

Scheme 13

Barton has also prepared vinyl formamides by the reduction of ketoximes *e.g.* (129) with *n*Bu₃P and diphenyldisulfide. *In situ* trapping with S-formyl-*p*-thiocresol is followed by oxidation of the intermediate α -thioformamide to generate a sulfoxide. Subsequent base catalysed elimination provides the required vinyl formamide, Scheme 14.¹⁵¹

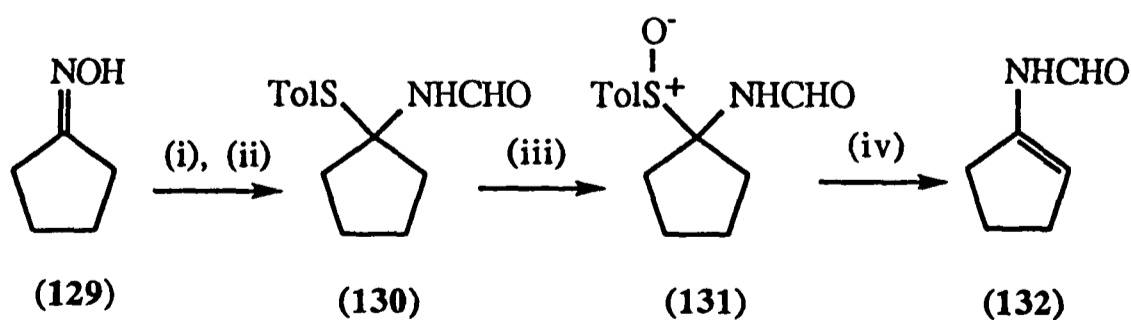

(i) *n*Bu₃P (2.2 eq.); (ii) (PhS)₂, TolSCHO; (iii) *m*-CPBA (1.1 eq.); (iv) K₂CO₃ (20 eq.)

Scheme 14

In 1990, Baldwin *et al.* whilst developing methodology for the total synthesis of isonitrins A, B and C reported that treatment of some thiooximes with triphenylphosphine and acetic formic anhydride gave the corresponding vinyl formamide under essentially neutral conditions, Scheme 15. The procedure was applied to a variety of relatively simple thiooximes as indicated in Table 1.^{131,152} The thiooximes were generally available from the corresponding ketone or amine according to the procedures of Morimoto *et al.*¹⁵³ and Gordon and Pluscec¹⁵⁴ respectively, Scheme 16.

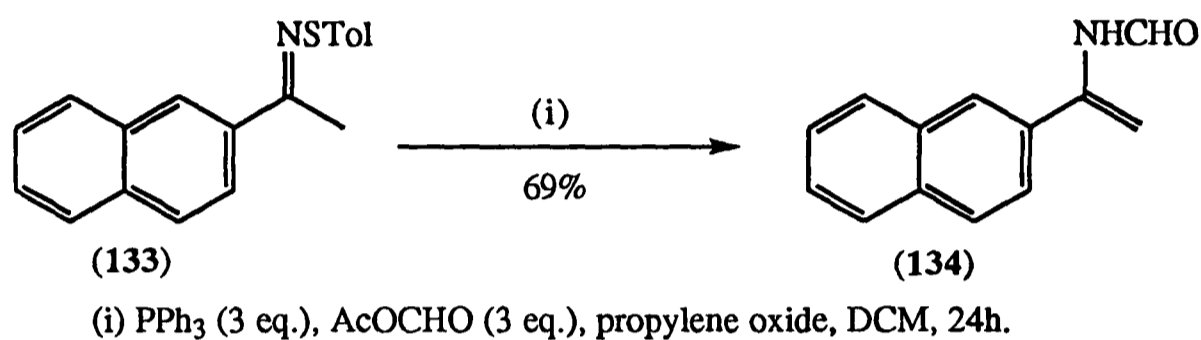

Scheme 15

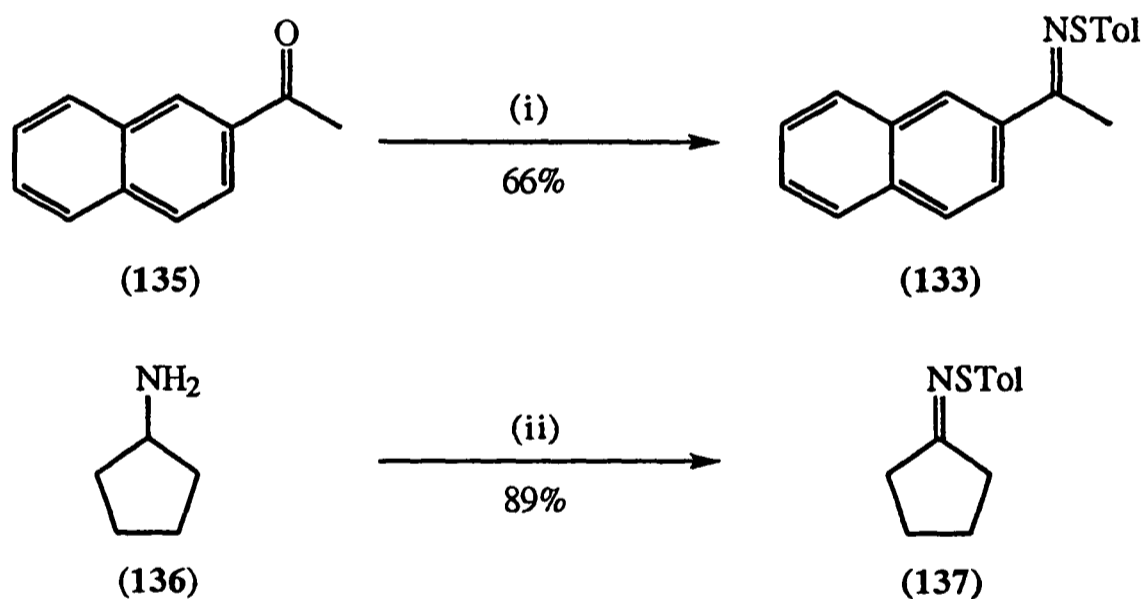

(i) $\text{ToISN}(\text{TMS})_2$, TBAF, THF; (ii) ToISCl (3 eq.), propylene oxide, mol. sieves.

Scheme 16

Barrett *et al.* have recently reported the synthesis of a number of vinyl formamides *e.g.* (141) from carboxylic acid chlorides *via* the corresponding phenylselenocarbamates.¹⁵⁵ The acid chlorides were converted to the selenocarbamates by a Schmidt rearrangement of the derived acyl azides followed by the addition of benzeneselenol to the intermediate isocyanate. Triⁿbutylstannane reduction of the selenocarbamate afforded the desired vinyl formamide, Scheme 17.

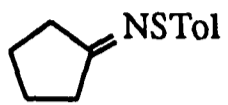
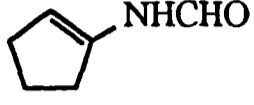
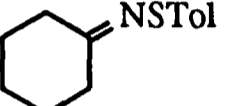
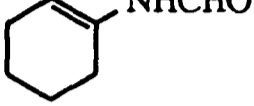
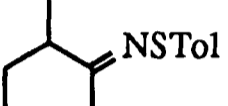
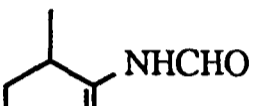
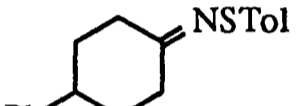
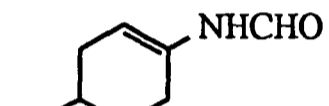
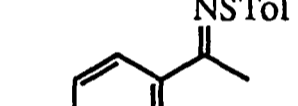
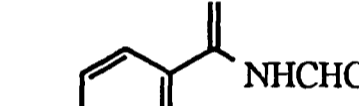
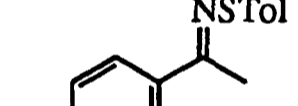
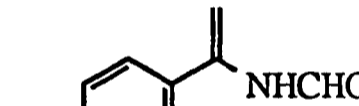
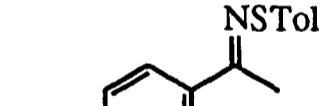
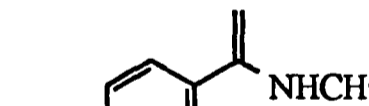
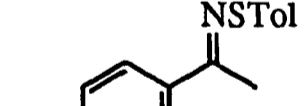
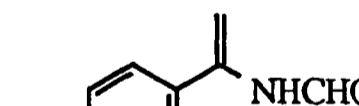
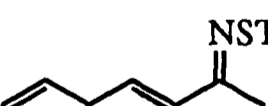
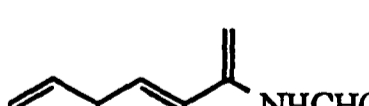
	THIOOXIME	% YIELD THIOOXIME	VINYL FORMAMIDE	% YIELD VINYL FORMAMIDE
1		89 ^a		68
2		88 ^a		76
3		94 ^b		58
4		89 ^a		80
5		89 ^a		81
6		92 ^a		86
7		96 ^a		85
8		66 ^b		68
9		69 ^a		86

a) Purified by recrystallisation from pentane at -30°C.

b) Purified by chromatography on flash silica

Table 1

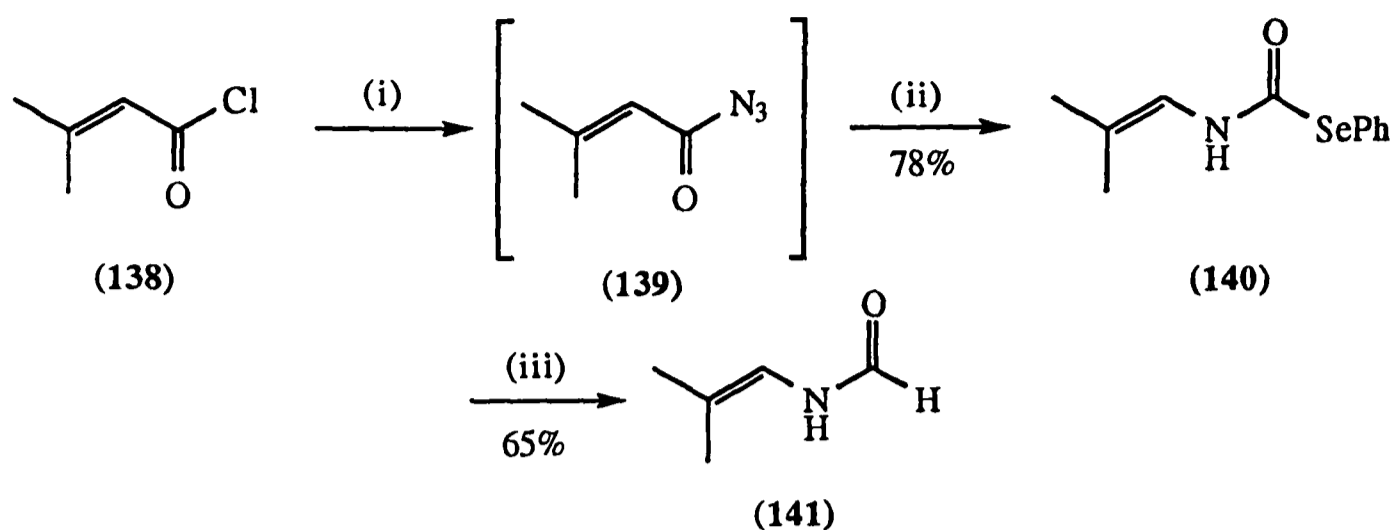

(i) NaN_3 , DMF; (ii) PhMe, heat then PhSeH, $t\text{-BuOK}$ (cat.); (iii) Bu_3SnH , AIBN, PhH, heat.

Scheme 17

The synthesis of α -(formylamino)acrylic esters by the condensation of α -metallated isocyanoacetic esters *e.g.* (143) with aliphatic or aromatic aldehydes and ketones was originally developed by Schöllkopf *et al.*, Scheme 18.¹⁵⁶ Applying this methodology, Suzuki has prepared a large number of formylimino derivatives by varying the ester functionalities and the functional groups at the double bond terminus. Biological assays have shown them to be inactive against a variety of organisms. The corresponding isonitriles obtained by dehydration, however, exhibited interesting antifungal activity.¹⁵⁷ Schöllkopf's application of this methodology to the synthesis of antibiotic A-32390A will be discussed in Chapter 3.

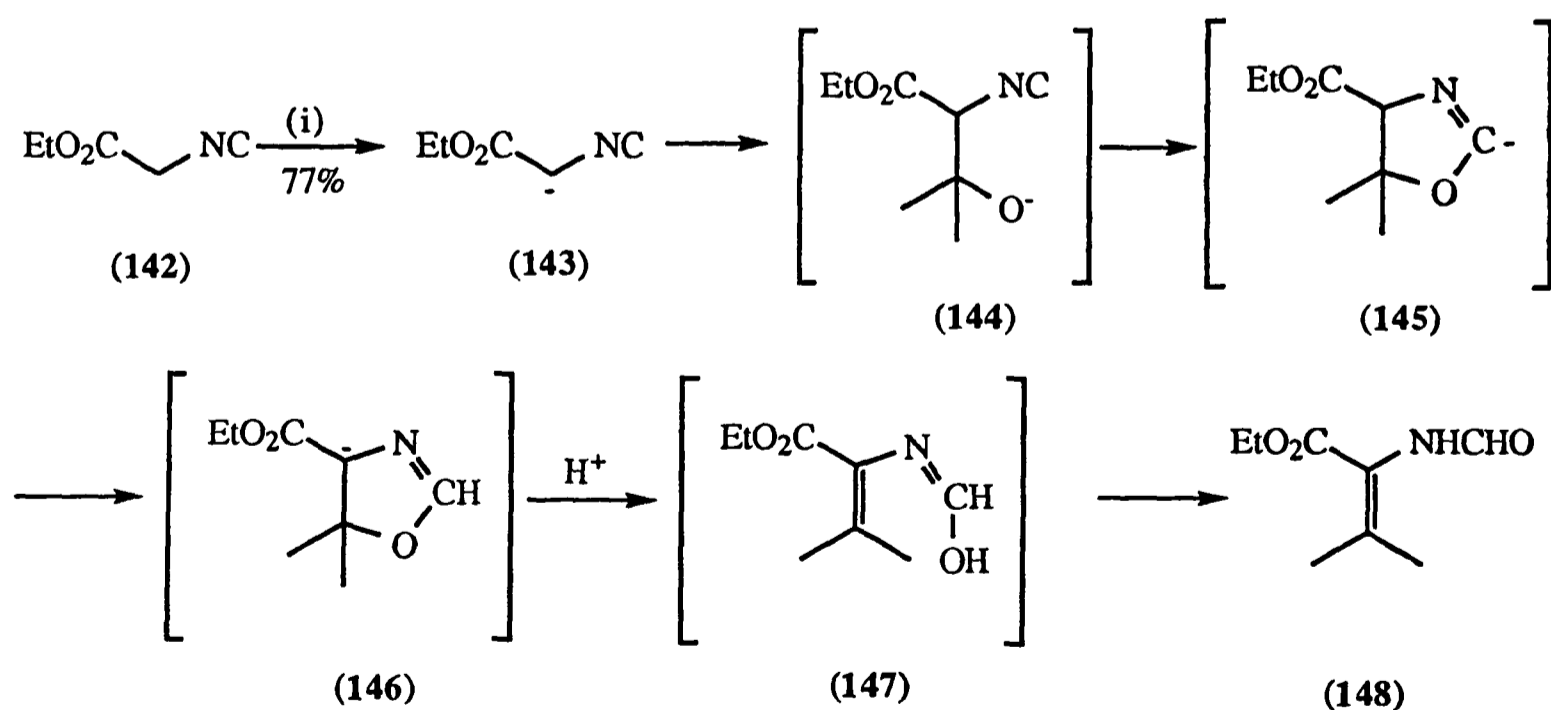

(i) $n\text{BuLi}$, THF, -60°C to RT.

Scheme 18

Kende has shown that γ -*N*, *N*-dibenzylamino α,β -dehydro *N*-formylamino acid esters such as (149) (prepared using the Schöllkopf methodology) undergo a novel dyatropic thermal rearrangement in refluxing toluene to yield the isomeric urea derivative. The following dissociation-recombination mechanism was proposed, Scheme 19.¹⁵⁸

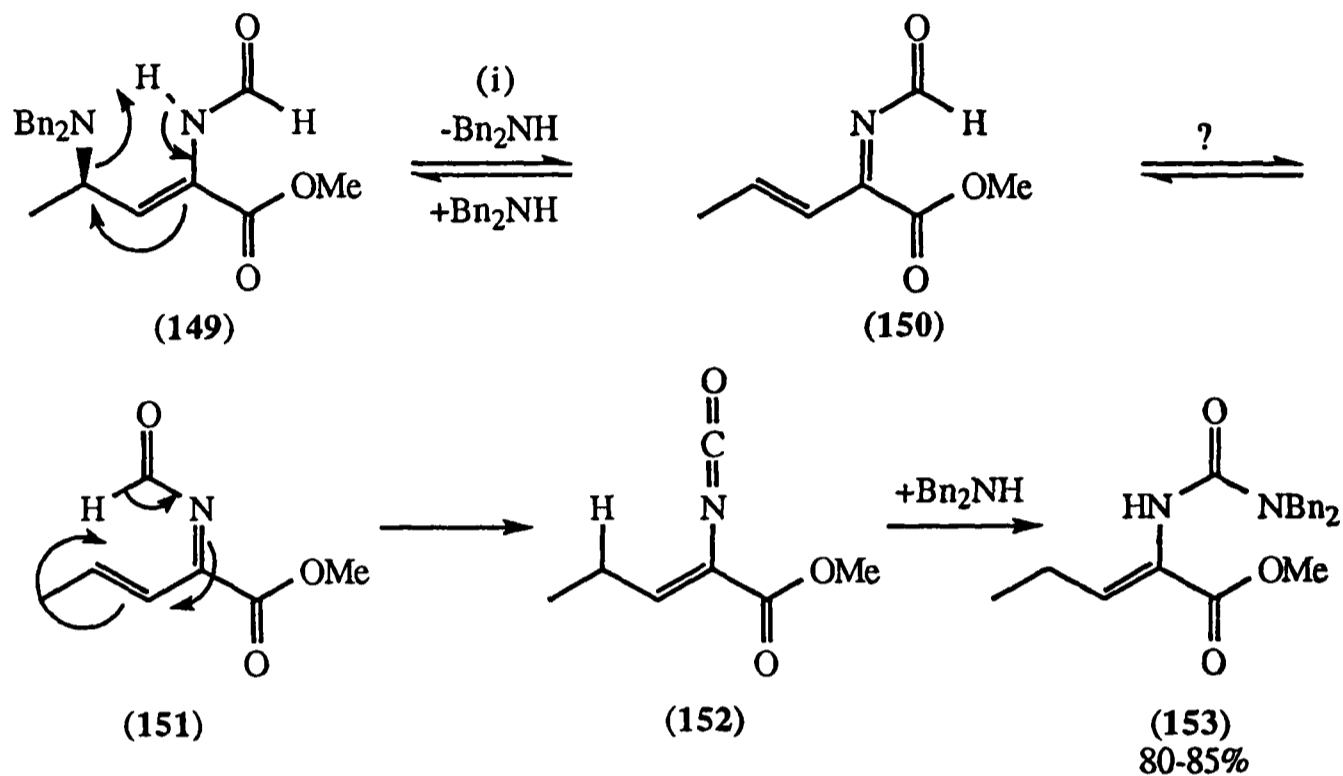

Scheme 19

p-Toluenesulfonylmethyl isocyanide (TOSMIC), an important synthetic synthon, has been applied to the synthesis of vinyl formamides. Erbstatin (157), a natural product, obtained from a strain of *Streptomyces*,^{159,160} has attracted interest as an inhibitor of tyrosine-specific protein kinase. One recent synthesis of (157) involved the condensation of metallated TOSMIC with aldehyde (154) to generate vinyl formamide (155) with *E*-stereochemistry. Isomerisation of the double bond, reductive tosylation with sodium borohydride and *O*-demethylation then generated (157), Scheme 20.¹⁶¹

The following two examples of the synthesis of naturally occurring isonitriles demonstrate alternative ways of generating the vinyl formamide moiety. Isonitrile 270 (10) has been the subject of two syntheses.^{162,163} Chondrogianni's synthesis involves the generation of the vinyl isonitrile by dehydration of the vinyl formamide, prepared by treatment of ketone (161) with formamide, Scheme 21.

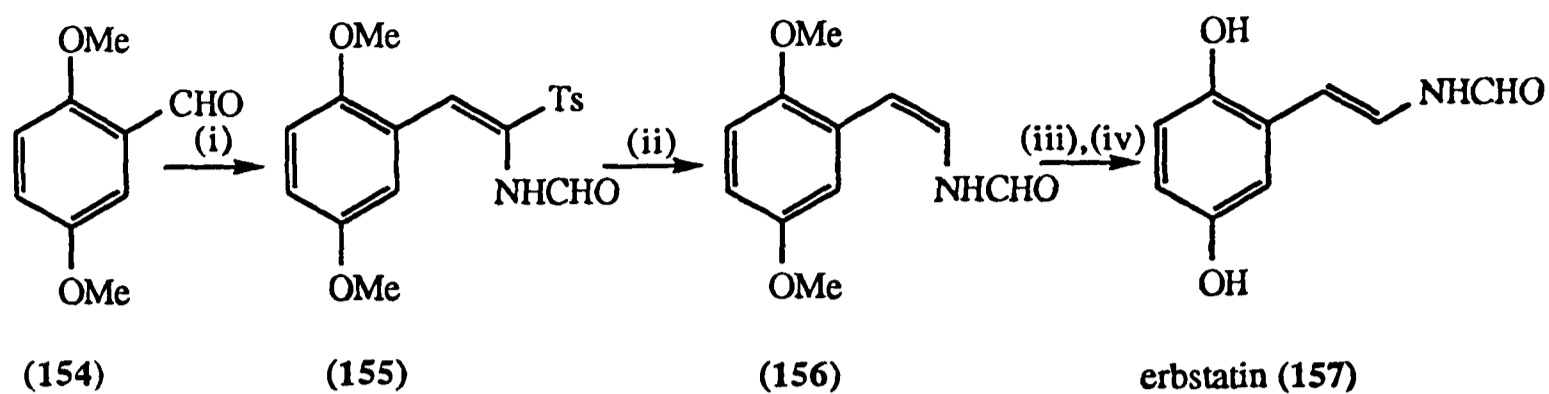

(i) TsCH₂NC, ^tBuOK, THF, -20°C, 45min., 76%; (ii) NaBH₄, DMF, 60°C, 30min., 36%;
 (iii) *hν*, I₂/toluene, 80°C, 3 h., 39%; (iv) BBr₃, DCM, -78°C, 60min. then RT, 90min., 84%.

Scheme 20

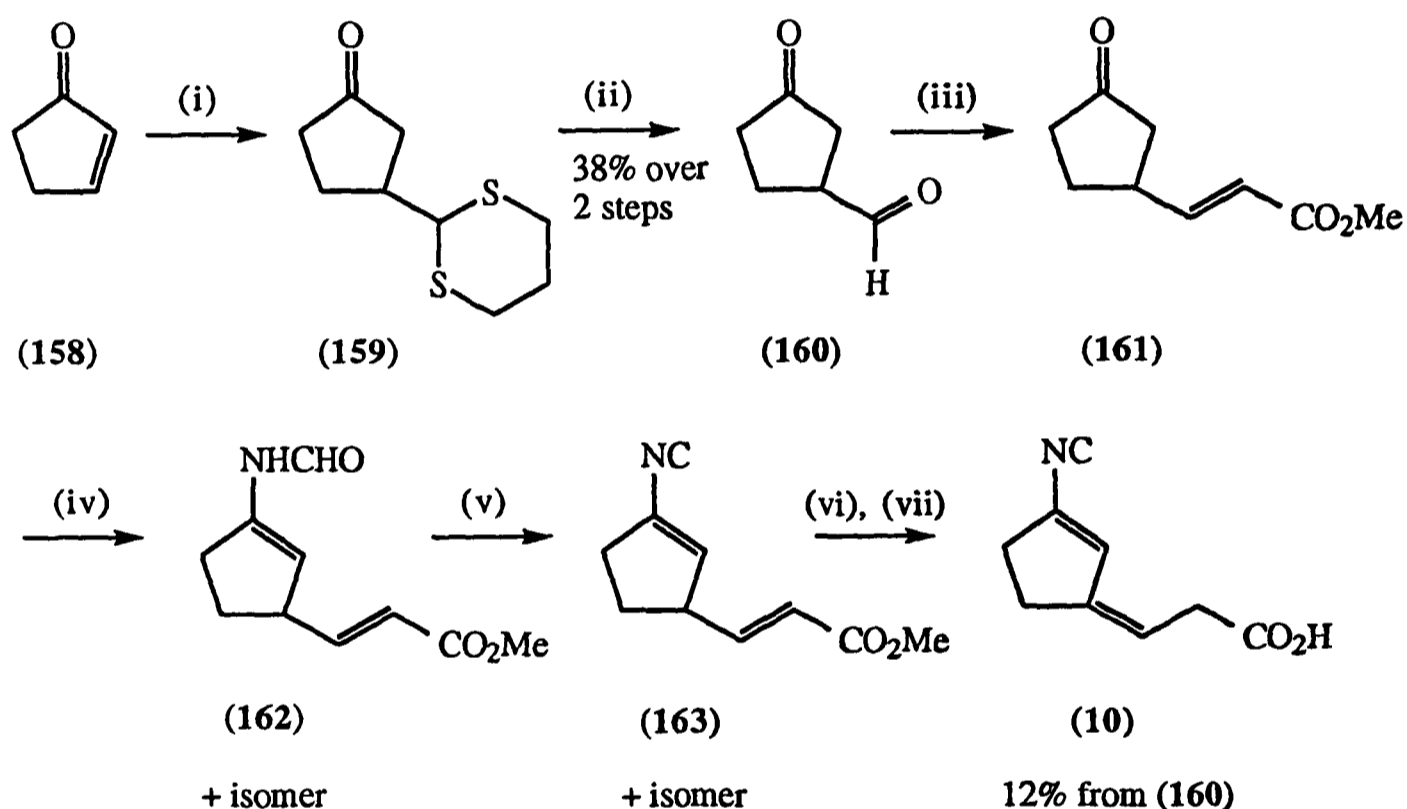

(i) ⁿBuLi, 1,3-dithiane, HMPA; (ii) HgCl₂; (iii) Ph₃P=CHCO₂Me; (iv) NH₂CHO;
 (v) COCl₂, Et₃N; (vi) LiOH, THF, 20°C; (vii) 0.1M HCl added until pH=3-4.

Scheme 21

Axisonitrile-4 (172), axamide-4 (171) and axisothiocyante-4 (173) are a triad of compounds isolated in very small amounts from the sponge *Axinella cannabina*.¹⁶⁴ Their structures are based on the dehydroaxane skeleton and thus (172) is unusual amongst the marine metabolites in possessing the vinyl isonitrile functionality. Racemic syntheses of (171), (172) and (173) were reported by Hart *et al.* in 1992.^{165,166} Construction of the axane skeleton was achieved by using a potassium ^tbutoxide catalysed cyclisation of the isomers of (167) to generate (168). Formation of acid (169) was followed by conversion to

isocyanate (170) by a Curtius rearrangement. Treatment of (170) with lithium triethylborohydride afforded axamide-4 (171). Dehydration with *p*-toluenesulfonyl chloride and pyridine gave (172). Finally, heating (172) with sulfur afforded (173).

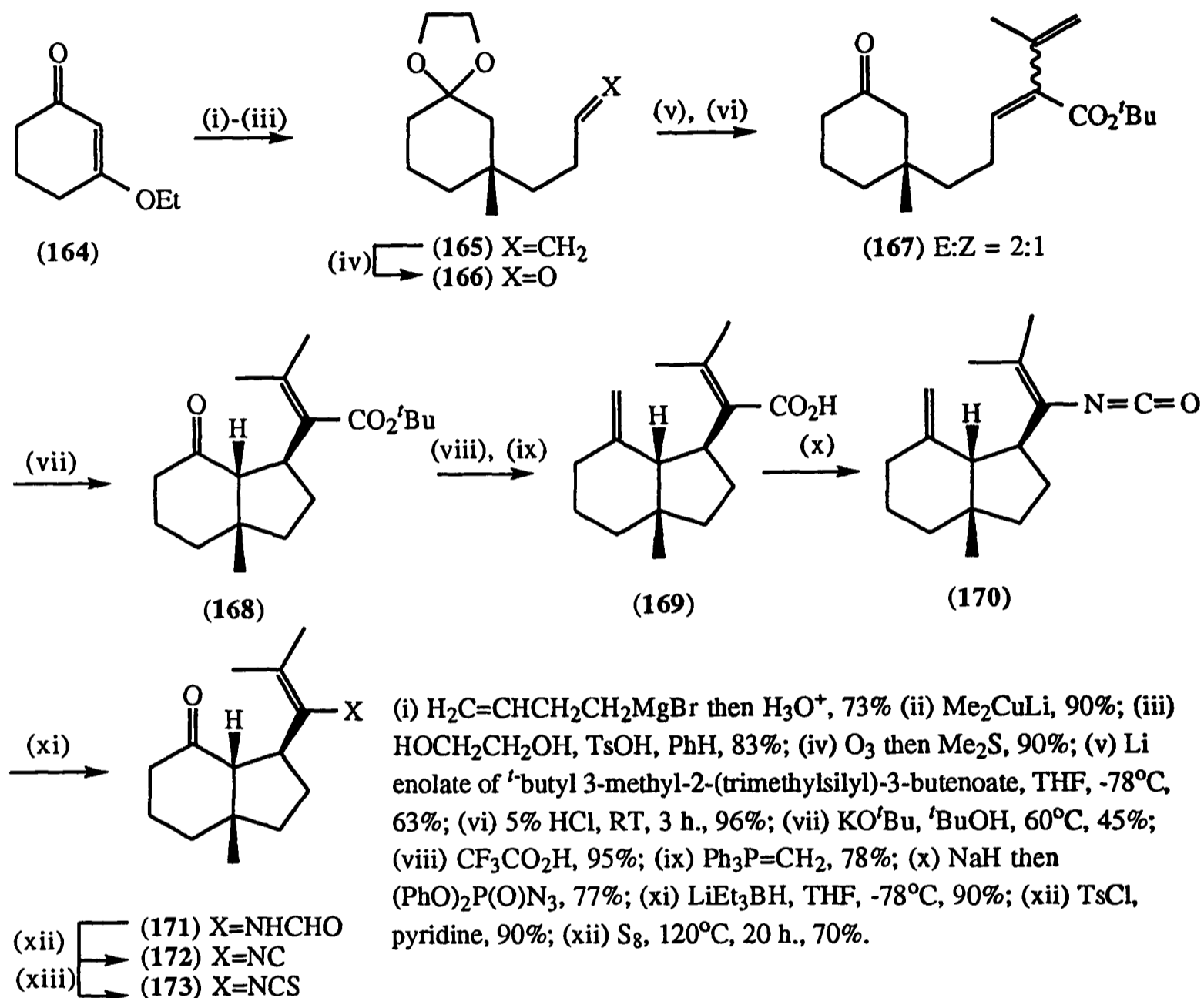

Scheme 22

Other naturally occurring vinyl isonitriles that have been synthesised by dehydration of the corresponding vinyl formamide include xanthocillin X dimethylether (2),^{11,13} dermadin,¹⁶⁷ spiro lactone (12)¹⁶⁸, the hazimycins (67) and (68),⁹⁹ and homothallin II.¹

2.2.3 Epoxy Isonitrile Synthesis

The epoxy isonitrile functionality is extremely rare in nature. The only examples known to date are trichoviridin (16), aerocyanidin (70), carvernoisonitrile (24), (11) and (17).¹⁶⁹

Two methods have thus far been developed for the preparation of epoxy isonitriles. The first approach by Schöllkopf *et al.* involves the Michael addition of basic hydrogen peroxide to an isonitrile substituted acrylate, Scheme 23.¹⁷⁰ The methodology is not applicable to the synthesis of unfunctionalised epoxy isonitriles as the ester group is essential to the success of the reaction.

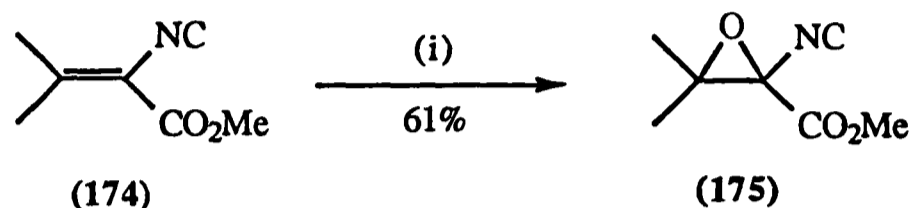

(i) H₂O₂, NaOH, 0°C, MeOH.

Scheme 23

In 1990, Baldwin and O'Neil reported the first synthesis of simple epoxy isonitriles such as (177) by dehydration of the corresponding formamide.¹⁷¹ The novel methodology involved the epoxidation of a vinyl formamide using dimethyldioxirane to give an intermediate epoxy formamide. This was dehydrated *in situ* using triflic anhydride to afford the required epoxy isonitrile *albeit* in modest yield, Scheme 24. The use of triflic anhydride as dehydrating reagent was essential to the success of the reaction. Phosgene based reagents failed to deliver any of the desired product.

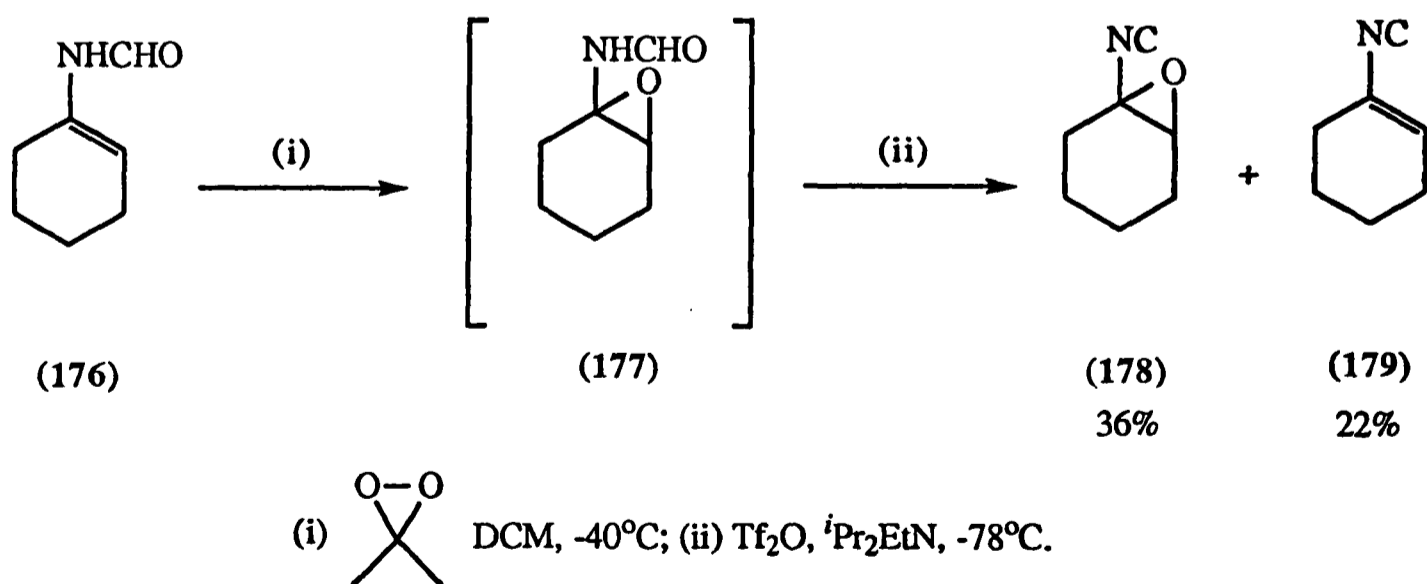

Scheme 24

2.2.4 α -Heteroatom Substituted Isonitrile Synthesis

Few reports exist on the synthesis and chemistry of α -heteroatom substituted isonitriles. Recently, however, Katritzky has synthesised α -morpholinobenzyl isonitrile (**185**) and a number of alkyl and arylthio isonitriles (**183**) by dehydration of the corresponding formamides, prepared by reaction of morphine or thiols with 1-(1-formylaminoalkyl)benzotriazoles, Scheme 25.¹⁷²

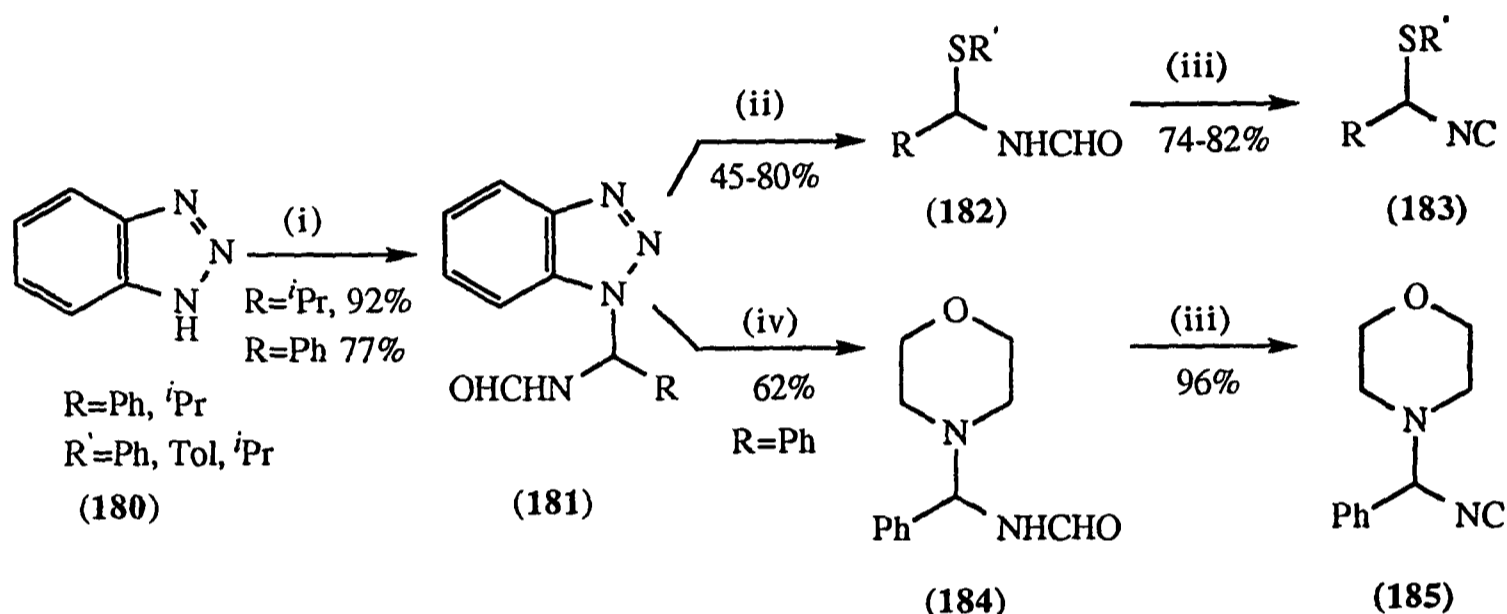

(i) RCHO , NH_2CHO ; (ii) $\text{R}'\text{SH}$, EtOH , Na , RT , 4 days; (iii) POCl_3 , DCM , 0°C , 4 h. then Na_2CO_3 , 20°C , 12 h.; (iv) morpholine, K_2CO_3 , MeOH , 20°C , 12 h.

Scheme 25

As noted previously, α -thioformamides are intermediates in Barton's synthesis of vinyl formamides, Scheme 14. See also Scheme 29 for the preparation of α -thio isonitriles.

2.3 Isonitrile Synthesis using Organometallic Cyanide

Trimethylsilylcyanide, like the cyanide ion, is ambident in character. The equilibrium that exists between the nitrile (**186**) and isonitrile (**187**) forms normally lies in favour of the former, Scheme 26.¹⁷³ The preparation of isonitriles has been effected in good yields by the use this reagent in the presence of a Lewis acid catalyst. Adamantyl isocyanide (**189**), for example, has been prepared from adamantyl chloride (**188**) using titanium tetrachloride as catalyst, Scheme 27.¹⁷⁴

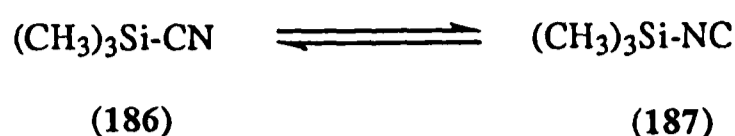

Scheme 26

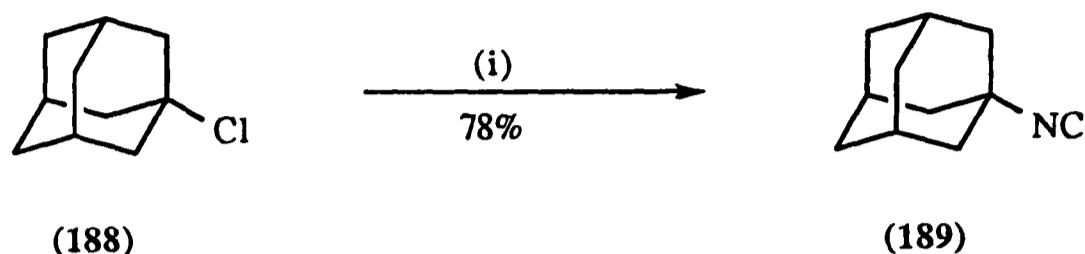
(i) TMSCN, TiCl_4 , DCM, 0°C , 150 min.

Scheme 27

The regiospecific and stereospecific ring opening of epoxides¹⁷⁵⁻¹⁷⁸ and oxetanes^{179,180} by TMSCN in the presence of ZnI_2 or ZnCl_2 proceed in good yields to afford β and γ -silyloxyisonitriles, respectively. Desilylation affords β and γ -hydroxy isonitriles from which the synthetically useful β and γ -hydroxy amines can be derived. In addition $\text{Pd}(\text{CN})_2$, Me_3Ga or SnCl_2 have also been shown to be effective in the ring opening of epoxides in this manner. A recent report has indicated that ring opening of epoxides can be effected in a similar fashion with TBDMSCN in the presence of ZnI_2 .¹⁸¹ The choice of Lewis acid in these reactions is critical. For example, if either AlCl_3 or Et_2AlCl are utilised in epoxide ring opening then formation of nitriles is observed.^{176,178}

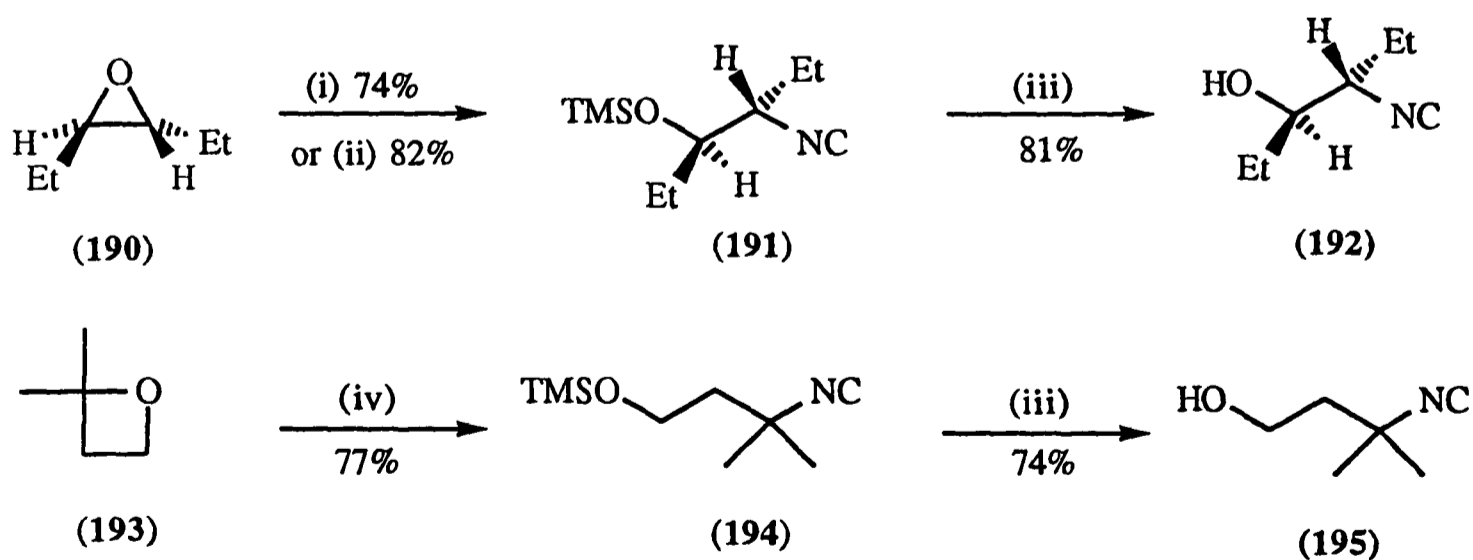

(i) TMSCN, ZnI_2 , DCM, -40°C , 10h.; (ii) TMSCN, $\text{Pd}(\text{CN})_2$, DCM; (iii) KF, MeOH;
 (iv) TMSCN, ZnI_2 , DCM, reflux, 24h.

Scheme 28

Recently, Yoshida reported that anodic oxidation of α -heteroatom substituted organotin compounds in $\text{Bu}_4\text{NBF}_4/\text{THF}$ and in the presence of TMSCN results in cleavage of the C-Sn bonds and exclusive formation of isonitriles, Scheme 29. On the other hand, the use of $\text{Bu}_4\text{NClO}_4/\text{DCM}$ results in the exclusive formation of nitriles. Spontaneous rearrangement of the α -heteroatom substituted isonitriles to nitriles was observed on the addition of Lewis acids.¹⁸²

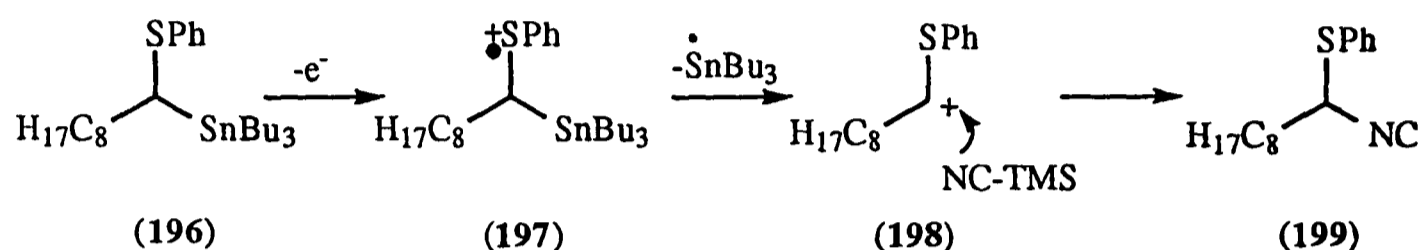

Scheme 29

The diterpene 7,20-diisocyanoadociane (**33**) was isolated from a sponge of the order *Adocia*⁶⁶ where it may function as a structural component in cell membranes.¹⁸³ The structure and relative configuration was established by X-ray analysis. However, a recent enantioselective synthesis by Corey has allowed the assignment of the absolute stereochemistry as that shown in (**33**), Scheme 30.^{184,185} The synthesis began with (1*R*, 2*S*, 5*R*)-(-)-menthol *via* (**200**) with key features for the construction of the carbon framework including the Diels-Alder reactions of (**203**) to *trans*-fused adduct (**204**) and later of (**205**) to the tetracyclic intermediate (**206**). The last step of the synthesis, introduction of the isonitrile groups was accomplished in a single biomimetic operation. Reaction of trifluoroacetate (**207**) with TMSCN and TiCl_4 gave a mixture of four diastomeric isonitriles one of which had structure (**33**).

2.4 Isonitrile Synthesis From Carbonic Acid Derivatives

Isonitriles exhibit carbene character and undergo α -addition reactions with a variety of species to generate carbonic acid derivatives (**208**).¹²⁶ Moreover, isonitriles may be prepared by the α -elimination reactions of such derivatives, Scheme 31.

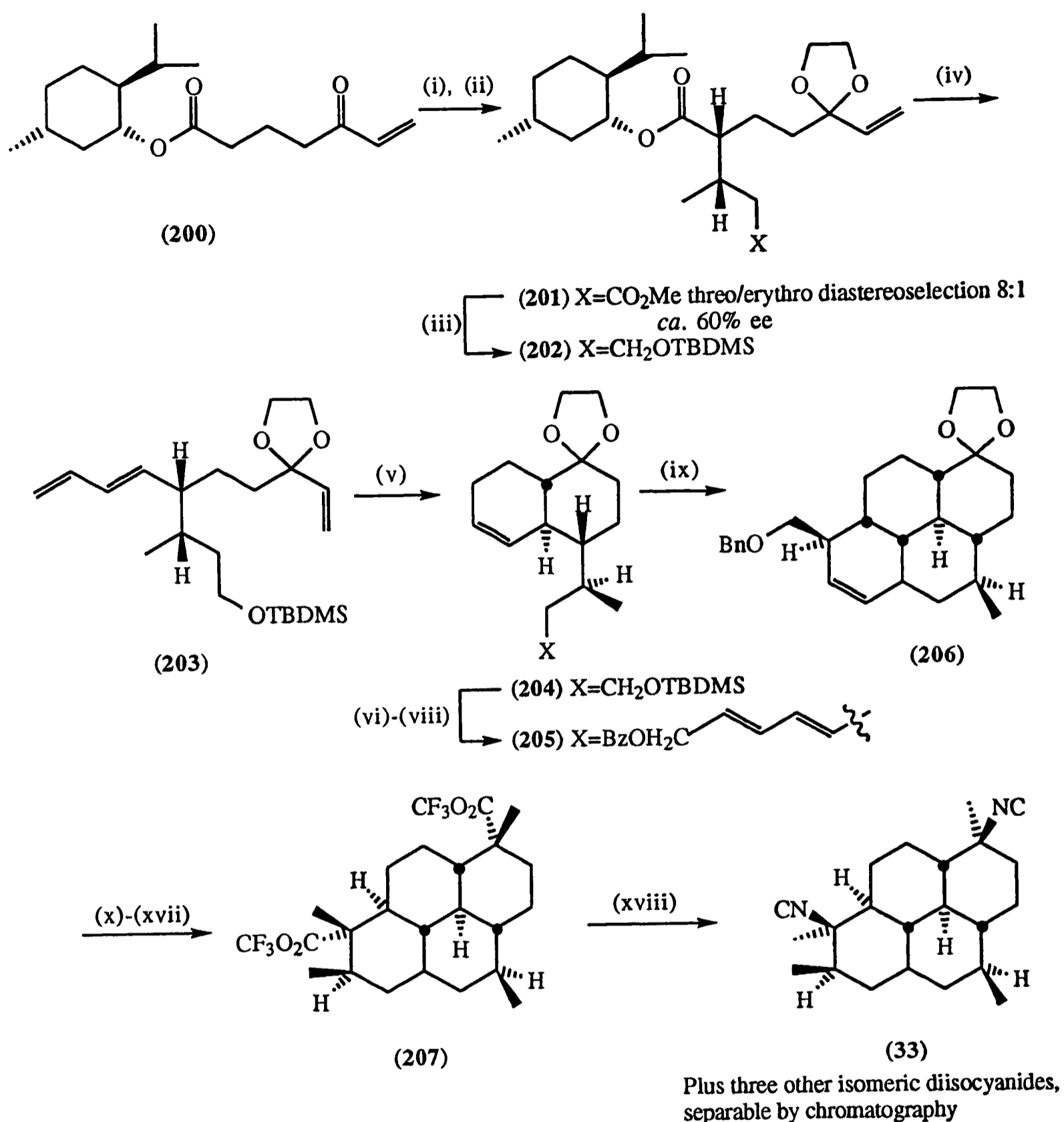

(i) PhSeTMS, ethylene glycol, I₂ (cat.), 65°C, 4 h. then *m*-CPBA, DCM, -20°C, 15 min., 99%; (ii) Me₂S, ⁱPr₂NH, 60°C then LDA, THF, -78°C then methyl *E*-crotonate, 80%; (iii) Red-Al, Et₂O, -40°C, 1.5 h. then TBDMSCl, Et₃N, DMAP, 85%; (iv) LiAlH₄, Et₂O, 23°C, 1.5 h. then PDC, mol. sieves, DCM, 23°C, 30 min. then methylallyldiphenylphosphonium bromide, KO^tBu, THF, 0°C, 45 min., 75%; (v) 150°C, toluene, 20 h., 90%; (vi) ⁿBu₄NF, THF, 23°C, 1.5 h. then PDC, mol. sieves, DCM, 82%; (vii) triethyl-4-phosphono-*E*-crotonate, ⁿBuLi, THF, 1 h., -78°C to 25°C, 70%; (viii) DIBAL, toluene, -20°C, 10 min. then NaH, BnBr, DMSO, 23°C, 30 min., 89%; (ix) 185°C, toluene, 36 h., 54%; (x) H₂, Pd/C, EtOH, 23°C, 4.5 h., 80%; (xi) PDC, mol. sieves, DCM, 80%; (xii) pyrrolidine, *p*-TsOH, PhH, 10 h., 90%; (xiii) RuO₄, CCl₄, 0°C then NaOMe, MeOH, 23°C, 2 min., 75%; (xiv) LDA, THF, -78°C, 15 min. then MeI then NaOMe, THF/MeOH, 23°C, 12 h., 90%; (xv) 0.5M HCl, aq. acetone, 99%; (xvi) MeLi, CeCl₃, THF, -78°C to 0°C, 2 h., 92%; (xvii) (CF₃CO₂)₂O, pyridine, DCM, 0°C, 20 min., 95%; (xviii) TMSCN, TiCl₄, 23°C, 3.5 hours, 70% (mix. of isomers).

Scheme 30

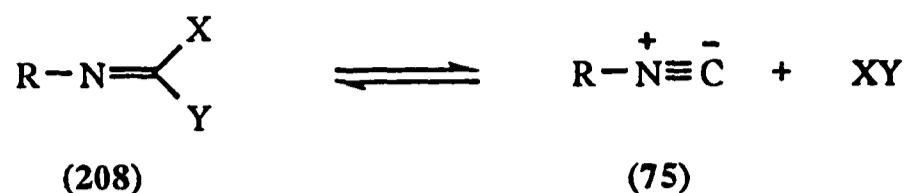

Scheme 31

Isothiocyanates, isocyanates and *N*-substituted formamides can also be easily converted to dichloroimines (X,Y=Cl), Scheme 32.¹⁸⁶ The reaction of simple aromatic and aliphatic dichloroimines *e.g.* (209) with potassium iodide or triphenylphosphine under vigorous conditions affords isonitriles in reasonable yield.¹⁸⁷ More recently, Guirado reported the high yielding preparation of simple aromatic and aliphatic isonitriles by cathodic reduction of the corresponding dichloroimines.¹⁸⁸ This reductive method has the advantage of being mild and 'reagent free', Scheme 32.

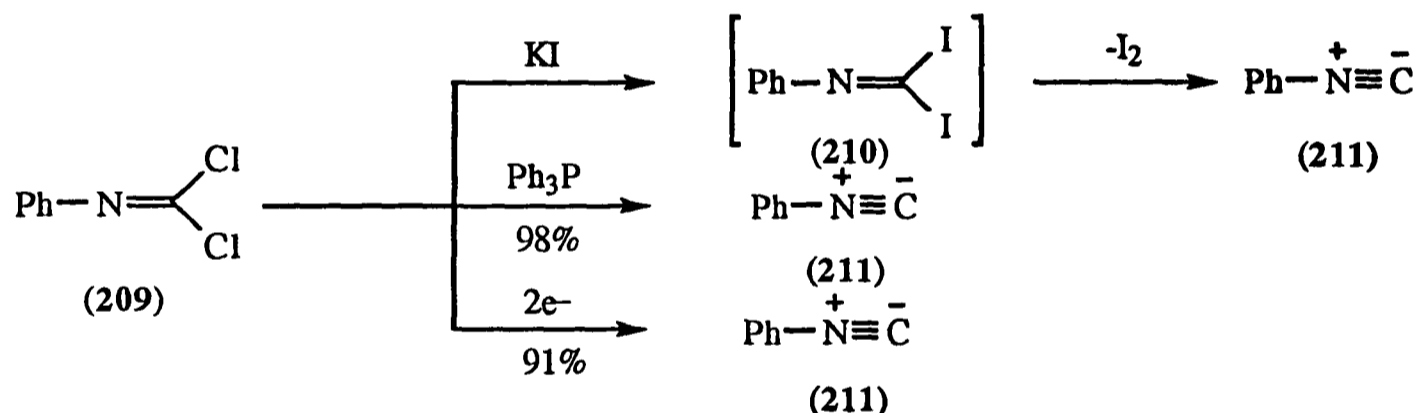

Scheme 32

Isonitriles may also be prepared by the reduction of the corresponding isocyanate. The use of simple phosphines and phosphites can be effective in certain cases but they suffer the drawback of requiring high temperatures.^{128,189} Baldwin *et al.* have utilised ^tbutyldiphenylsilyllithium and trichlorosilane/triethylamine to reduce isocyanates in high yields under mild conditions, Scheme 33. The trichlorosilane/triethylamine reagent is preferable on the grounds that it is less basic, more economical and allows for easier isolation of products.¹⁹⁰

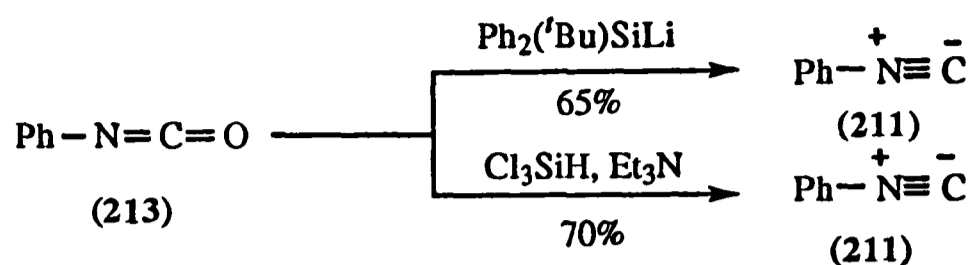

Scheme 33

This methodology has been utilised by Baldwin in the synthesis of vinyl isonitriles *e.g.* (207). Iodoisocyanation of an alkene according to the procedure of Hassner was followed by reduction to the corresponding iodoisonitrile. β -elimination generated the desired product, Scheme 34.¹⁹¹

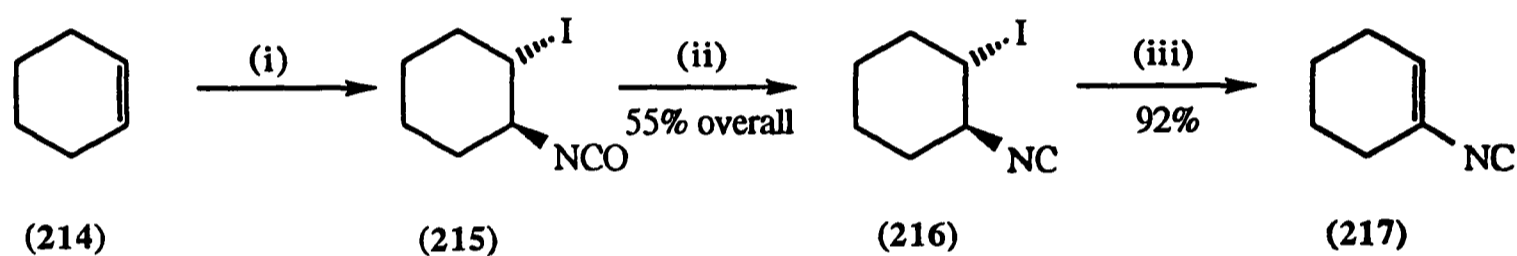

(i) AgOCN (1.3 eq.), I₂ (1 eq.), Et₂O, RT, 5 hours; (ii) LiOMe (cat.), MeOH;
 (iii) Cl₃SiH (1.5 eq.), ⁱPr₂EtN (2.5 eq.), DCM, 0°C, 30min.

Scheme 34

Reduction of both isocyanates and isothiocyanates can be effected at room temperature using Mukaiyama's reagent 2-phenyl-3-methyl-1,3,2-oxazaphospholidine (219), which suffers the disadvantage of being difficult to prepare and store, Scheme 35.¹⁹²

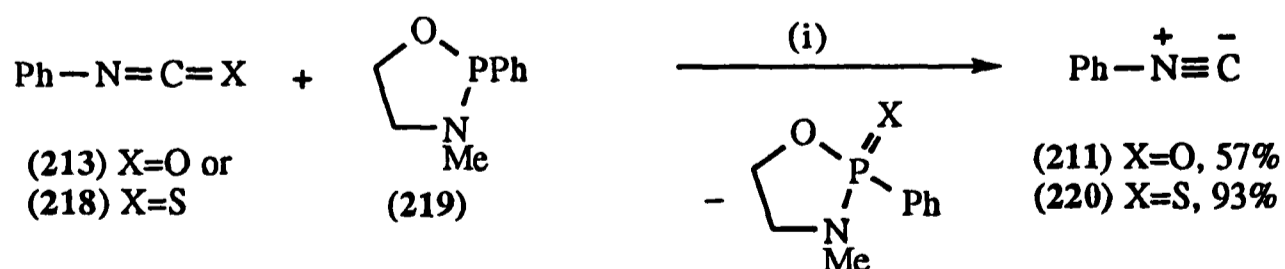

(i) petroleum ether, reflux.

Scheme 35

Isothiocyanates can also be reduced with triethylphosphine,¹⁹³ copper,¹⁹⁴ triphenyltinhydride¹⁹⁵ or photochemically.¹⁹⁶

2.5 Isonitrile Synthesis using Metallated Isonitriles (with Retention of the Isonitrile Group)

Alkyl isonitriles can be metallated at the α -position, *albeit* not quite as readily as alkyl nitriles,^{197,198} with the stabilisation of the negative charge resulting primarily from the inductive effect (field effect) of the strongly electronegative *sp*-hybridised nitrogen atom.¹⁹⁹ α -Metallated isonitriles react with a wide range of electrophiles including halides, imines and carbonyl compounds, epoxides, oxetanes, Scheme 36, and have found significant use as (*inter alia*) synthons for α -metallated primary amines and in the preparation of heterocycles.^{197,198,200} Metallated *p*-toluenesulfonylmethyl isocyanide (TOSMIC) (227), in particular, has found many applications in organic synthesis.

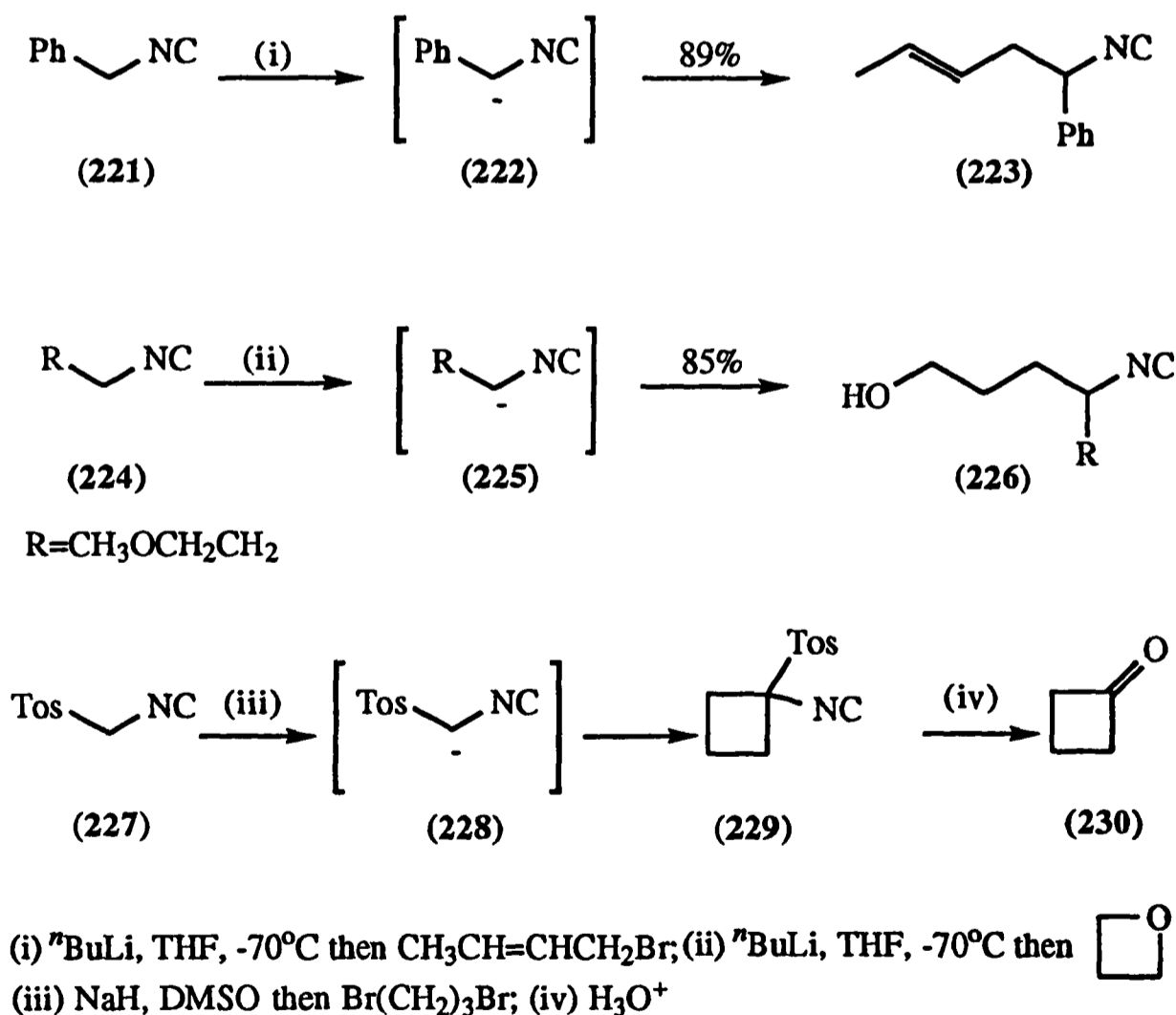

Scheme 36

The synthesis of vinyl isonitriles has been accomplished by Schöllkopf using metallated isonitriles with aldehydes by trapping of the alkoxide intermediate *in situ* with *p*-toluenesulfonic chloride. Elimination of *p*-toluenesulfonic acid then generates the desired vinyl isonitrile, Scheme 37.¹⁹⁷

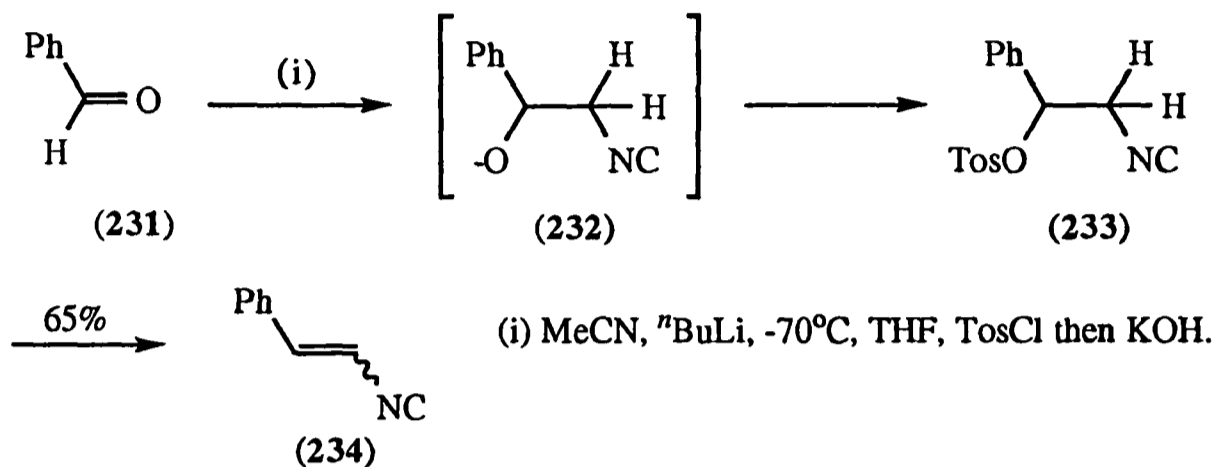

Scheme 37

Schöllkopf later used α -metallated isocyanophosphonates in a Wittig reaction to generate vinyl isonitriles.²⁰¹ Mixtures of *cis* and *trans* isomers were obtained with the latter predominating. In contrast, Baldwin and Lombard have shown that the *cis* isomer predominates when metallated (trimethylsilyl)methyl isocyanide is reacted in a Peterson type reaction, Scheme 38.²⁰²

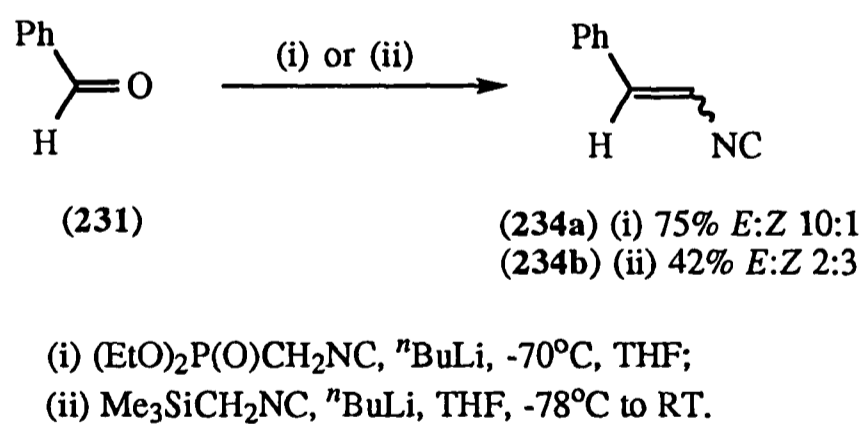

Scheme 38

2.6 Isonitrile Synthesis by Displacement of Halide by Cyanide

The displacement of a halide by the ambident cyanide ion was the first method discovered for the synthesis of isonitriles, see Section 2.1.^{126,127} In recent years there has been a revival in the use of this strategy with silver cyanide in particular allowing for the

preparation of a variety of novel isonitriles such as α -acyloxyisonitriles (**237**)²⁰³ and glycosyl isonitriles (**239**),²⁰⁴ Scheme 39.

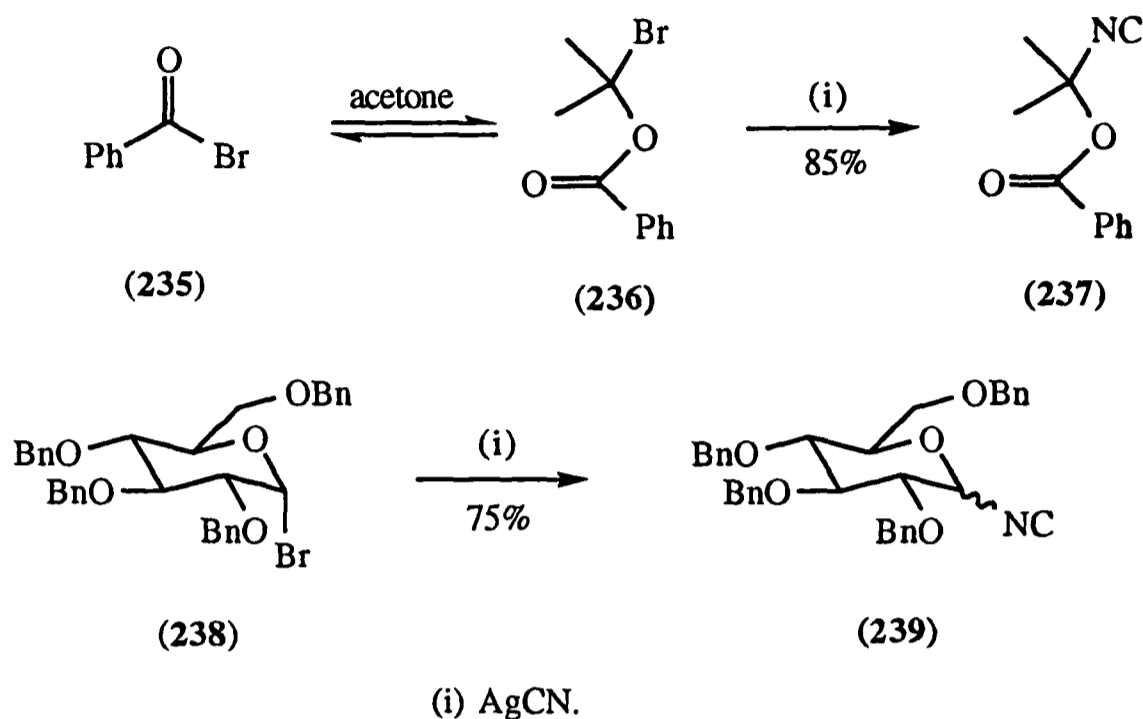

Scheme 39

2.7 Isonitrile Synthesis using the Hofmann Carbylamine Reaction

The carbylamine reaction *i.e.* the reaction of primary amines with chloroform in the presence of strong base, which is proposed to involve dichlorocarbene (**240**) as an intermediate, was another of the early methods of isonitrile synthesis. However, as a result of the low yields usually obtained, it was not considered to be preparatively useful. More recently the yields have been improved by the application of phase transfer catalysis. Weber demonstrated that the reaction of primary amines with either chloroform or bromoform and 50% sodium hydroxide in the presence of the phase transfer catalyst, benzyltriethylammonium chloride, produced isonitriles (**75**) in 40-60% yield.²⁰⁵ A similar procedure was also applied by Jakobsen to the preparation of *N*-isocyanoimines (**241**).²⁰⁶

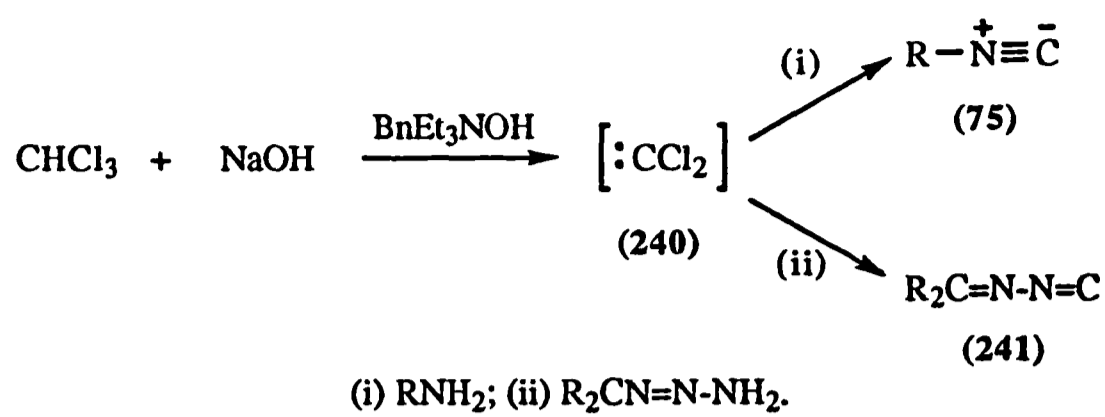

Scheme 40

2.8 Other Methods for the Preparation of Isonitriles

Other methods for the preparation of isonitriles are, *inter alia*, the thermolysis of *N*-hydroxyformamidines, the isomerisation of nitriles and the copper catalysed addition of HCN to tertiary olefins. These approaches have received little attention of late and have been extensively reviewed elsewhere.¹²⁶⁻¹²⁸

Chapter 3

**The Synthesis of a Biologically Active Analogue of Antibiotic
A-32390A****3.1 Antibiotic A-32390A-Isolation and Biological Activity**

In the course of screening for microorganisms that produce dopamine β -hydroxylase inhibitors, Eli Lilly discovered an organism of the genus *Pyranochaeta* which contained several compounds that inhibited this enzyme.⁴⁰ One of these was antibiotic A-32390A which was assigned structure (18) on the basis of spectroscopic analysis and chemical degradation.²⁰⁷ Not only does A-32390A inhibit dopamine β -hydroxylase non-competitively (IC_{50} *in vitro* $1.7\mu\text{gcm}^{-3}$) but also reduces heart and adrenal norepinephrine levels in hypertensive rats, shows a broad spectrum of activity against Gram positive bacteria and is antifungal against the pathogen *Candida albicans*.²⁰⁸ The requirement for antimicrobial agents to cure candidiasis and other invasive fungal infections, which undermine the treatment of chronic diseases (*e.g.* rheumatoid arthritis, diabetes, asthma, cancer) and threaten immunocompromised patients such as those affected by AIDS (Acquired Immune Deficiency Syndrome),²⁰⁹ is omnipresent. The activity of (18) *in vivo* against *C. albicans*, coupled with its low toxicity, is therefore of particular biomedical interest.

3.2 Schöllkopf's Synthesis of A-32390A and Related Analogues

Antibiotic A-32390A (18) has been the subject of a synthesis by Schöllkopf and co-workers²¹⁰ who utilised a condensation reaction between methyl isocyanoacetate²¹¹ and acetone followed by hydrolysis to obtain the key vinyl formamide (244). Two of these units are subsequently coupled to a derivative of (*D*)-mannitol to afford (246) which is then elaborated to the target material, Scheme 41. Structural variants, in which (*D*)-mannitol²¹²

was replaced by (*L*)-threitol and/or where the groups on the double bond were modified *e.g.* (249) and (250), were prepared in an analogous manner, and their efficacy against various bacterial and fungal strains demonstrated, Figure 12.

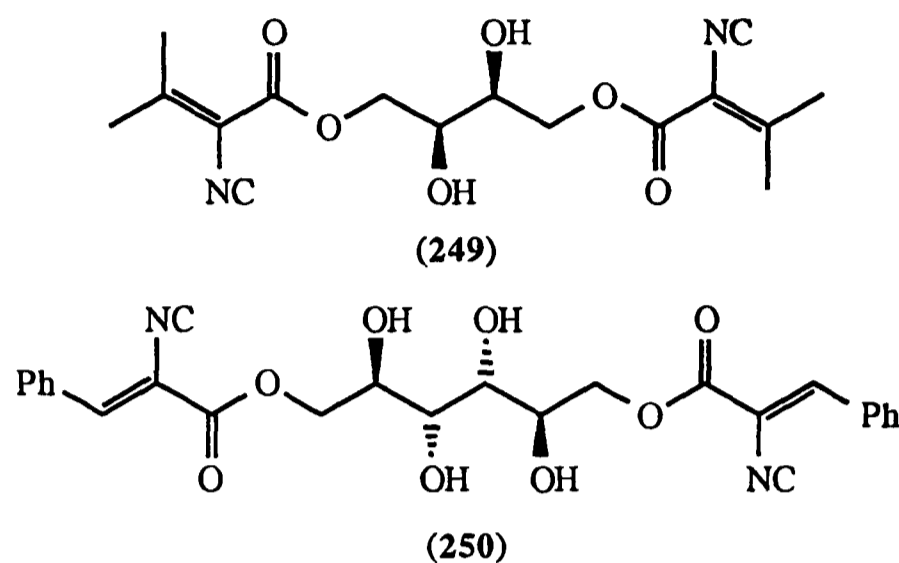

Figure 12

A number of problems exist with the Schöllkopf syntheses. Firstly, due to the instability of the isonitrile functionalities under the conditions required for the removal of the benzylidene protecting groups, modification of the hydroxyl protecting groups to the *O*-formyl esters is required at a late stage of the synthesis, subsequent removal of which is low yielding (*e.g.* 32% and 23% for the synthesis of (18) and (249) respectively). Secondly, the dehydration of the vinyl formamide with phosphorus oxychloride is inefficient, yielding (18) and (249) in only 54% and 68% respectively.

3.3 Previous Synthetic Studies Towards a Biologically Active Analogue of A-32390A

3.3.1 Introduction

Systems pertinent to antibiotic A-32390A (18) have been examined by ourselves in an effort to further define the scope and limitations of Baldwin's thiooxime to vinyl formamide rearrangement,^{152,131} Scheme 15 and the use of triflic anhydride as a dehydrating agent for vinyl formamides, Scheme 6.¹³⁰ This work was originally initiated as a Part II project, the results of which are summarised below following a discussion on the development of the rearrangement reaction.

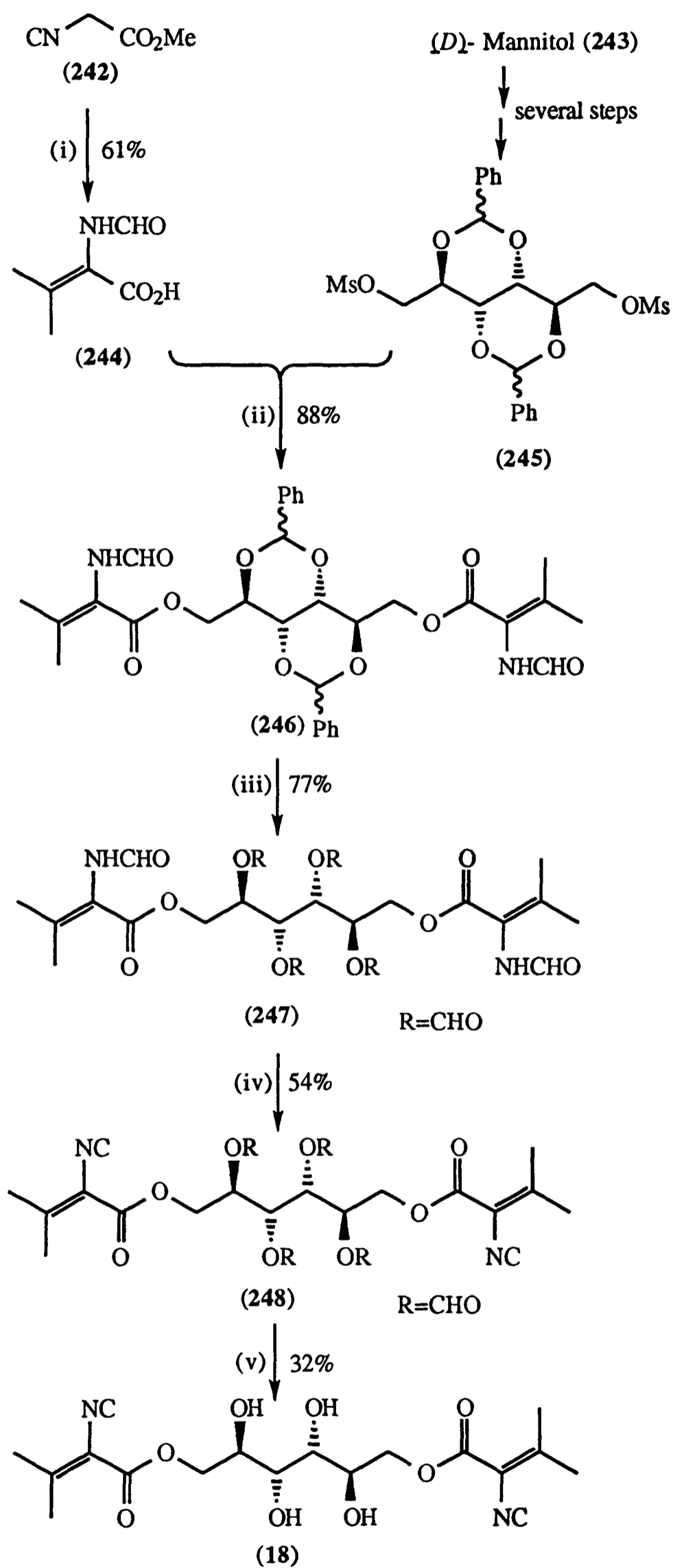

(i) $t\text{-BuOK}$ then acetone then H^+ then Base; (ii) Et_3N , HMPA, DMF; (iii) pyridine, AcOCHO ; (iv) Et_3N , POCl_3 , DCM, 0°C ; (v) H_2O , NaHCO_3 , Na_2CO_3 , RT.

Scheme 41

3.3.2 Background to the Baldwin Thiooxime to Vinyl Formamide Rearrangement

Baldwin's thiooxime to vinyl formamide rearrangement, Scheme 15, was originally designed based on the observations of Gordon *et al.* made during their studies on the partial synthesis of cephamycin antibiotics.²¹³ The cephalosporin thiooxime (**252**) had been converted to an α -thioamine (**253**) by treatment with triphenylphosphine and silica gel. The mechanism outlined in Scheme 42 had been proposed by Gordon *et al.* Triphenylphosphine was proposed to undergo a reversible insertion into the N-S bond of the tolylthiooxime (**252**) to give intermediate (**254**). Physical and spectroscopic evidence was presented for this step. ¹³C n.m.r. experiments in which (**254**) was mixed with three equivalents of triphenylphosphine suggested an equilibrium existed between the thiooxime (**252**) and triphenylphosphine leading to formation of a complex which may have had a structure equivalent to (**254**). A separate experiment showed that almost complete recovery of (**252**) could be made by recrystallisation of a mixture of (**252**) and triphenylphosphine thus "emphasising the reversibility of complex formation." Following complexation the silica gel protonated the amine and migration of thiotolyl to carbon ensued to give intermediate (**255**) which underwent rapid hydrolysis with concomitant loss of triphenylphosphine oxide to generate α -thiotolylamine (**253**).

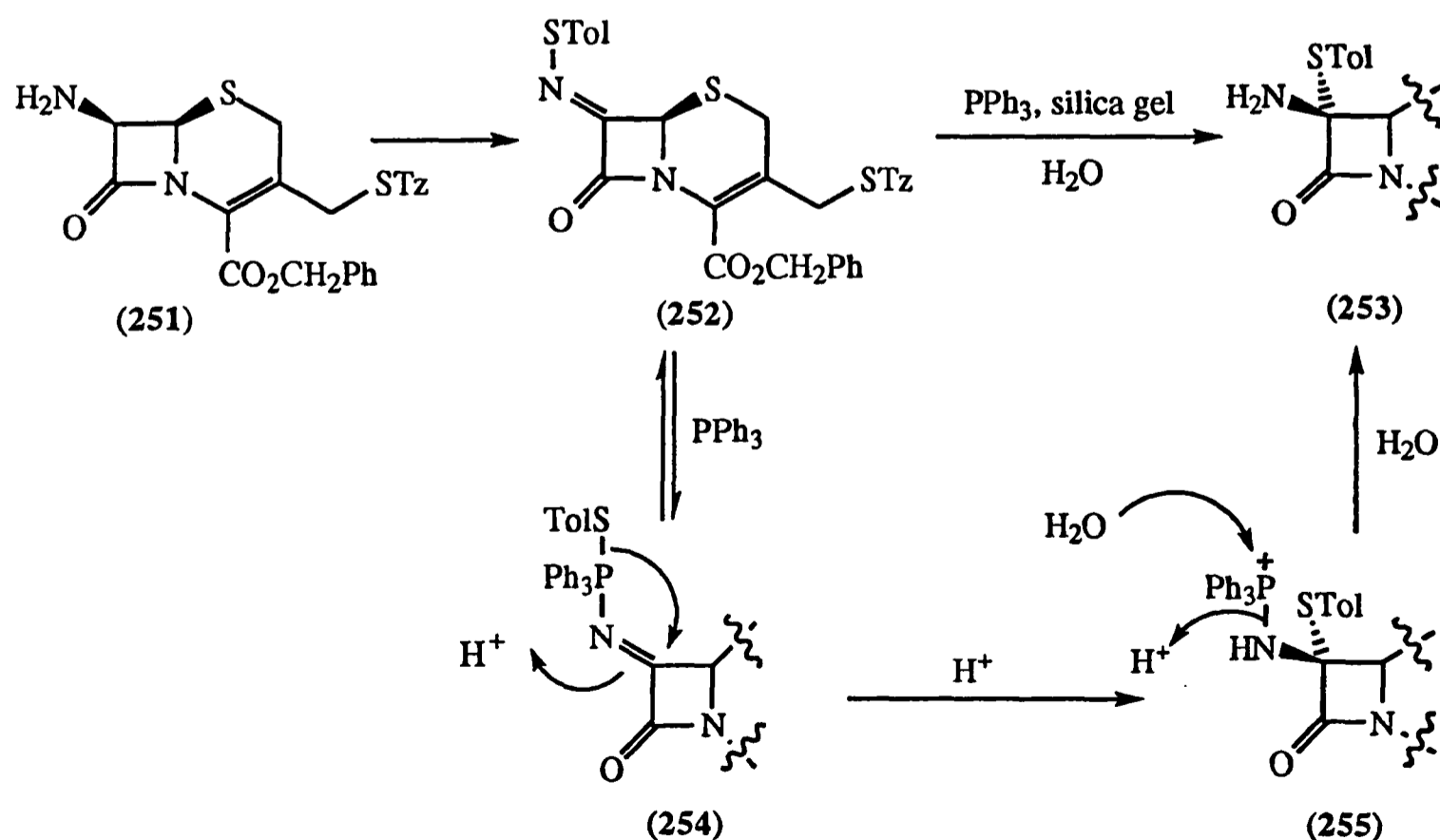

Scheme 42

It was argued that replacement of the proton source with a formyl source such as acetic formic anhydride would lead to the formation of an α -thioformamide.²¹⁴ However, it was subsequently demonstrated that for the majority of the systems to which such modified rearrangement conditions were applied only the vinyl formamide was isolated. In only a few complex cyclopentyl systems was an α -thioformamide isolated.^{214,215} The mechanism will be discussed in greater detail in Chapter 5.

3.3.3 Preliminary Evaluation

At the onset of this work no precedent existed for the rearrangement of α -carboxy thiooximes to vinyl formamides and thus in order to facilitate the investigation of the novel aspects of this proposal it was decided to probe the reactivity of less functionalised and more readily available substrates.²¹⁶ To this end, thiooxime (**257**) was prepared from (*L*)-valine benzyl ester (**256**) according to the method of Gordon.¹⁵⁴ Exposure of (**256**) to the rearrangement conditions failed to deliver any of the desired vinyl formamide, however, two *N*-formylated products, the α -thioformamide (**258**) and the α -acetoxyformamide (**259**) were isolated in reasonable yield. Preliminary experiments indicated that while the minor α -acetoxy formamide (**259**) underwent facile elimination to the desired vinyl formamide (**260**) upon treatment with DBU, treatment of the α -thioformamide (**258**) under equivalent conditions gave rise to a slow reaction and only a modest (40%) yield of (**260**). Treatment of (**258**) with $\text{Hg}(\text{OAc})_2/\text{Et}_3\text{N}$ was found to lead smoothly to (**259**) in 80% yield. A combination of $\text{Hg}(\text{OAc})_2$ and DBU in one synthetic operation gave a 70% yield of vinyl formamide (**260**) directly. Thus the desired transformation of (**257**) to (**260**) could be achieved by sequential treatment of the thiooxime (**257**) with PPh_3 , $\text{Hg}(\text{OAc})_2$ and DBU to afford vinyl formamide (**260**) in 55% overall yield. Hydrolysis of (**260**) afforded the free acid (**244**), a key intermediate in Schöllkopf's synthesis of A-32390A (**18**) and analogue (**249**), Scheme 41. Dehydration of (**260**) to the corresponding vinyl isonitrile (**261**) proceeded smoothly with triflic anhydride in the presence of *N,N*-diisopropylethylamine, Scheme 43.^{130,158} The highest yielding route to (**261**), however, involved the isolation of α -acetoxy formamide (**259**) by the addition of $\text{Hg}(\text{OAc})_2$ to the rearrangement reaction of (**257**), followed by a one pot elimination and dehydration, Scheme 44.

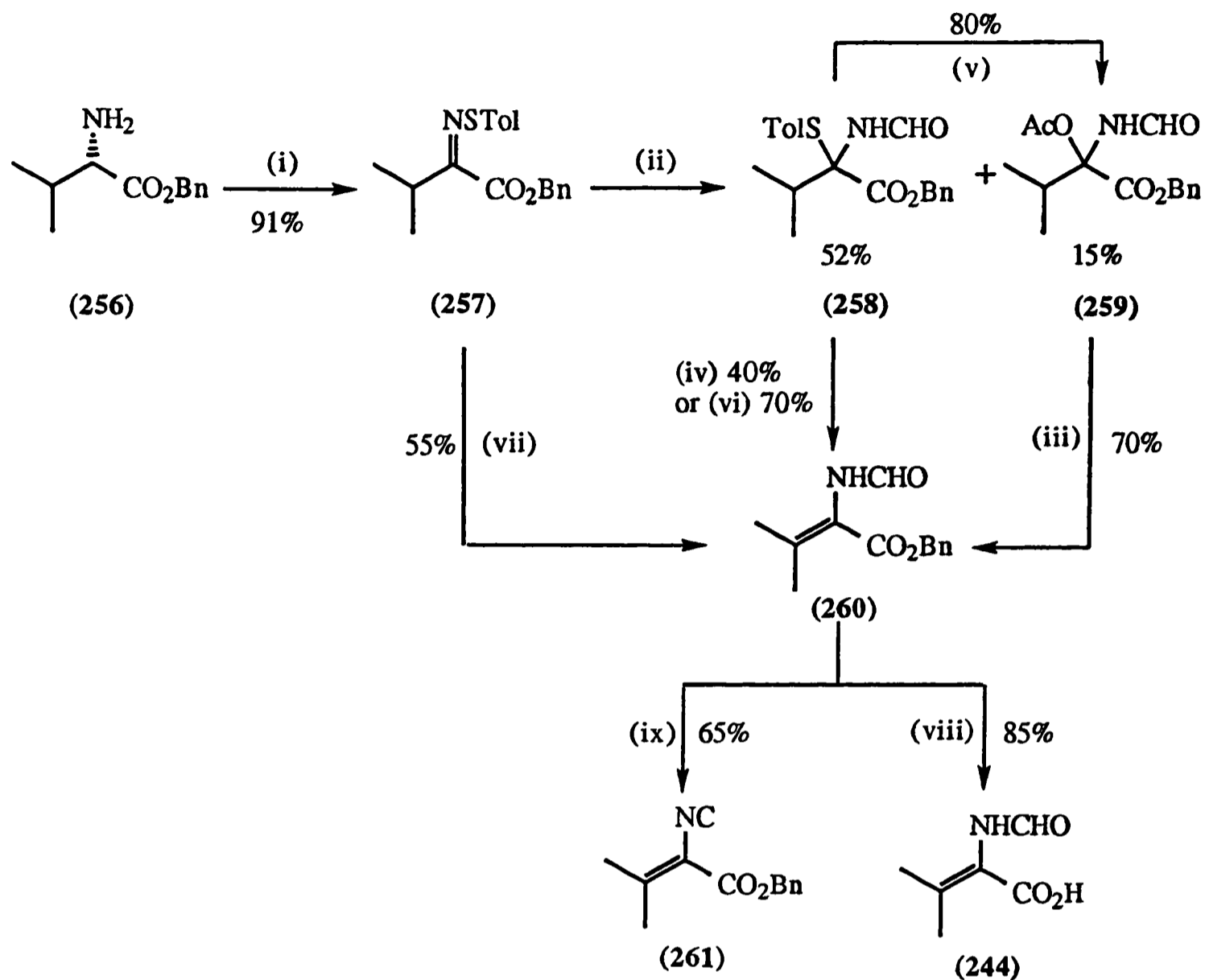

(i) *p*-TolSCl (3 eq.), propylene oxide (50 eq.), 4Å mol. sieves, DCM, 2h., RT; (ii) PPh₃ (3 eq.), AcOCHO (3 eq.), propylene oxide (10 eq.), DCM, RT; (iii) DBU (5 eq.), DCM, 30min., RT; (iv) DBU (5 eq.), DCM, 48h., RT; (v) Hg(OAc)₂ (1 eq.), Et₃N (5 eq.), DCM, 10min., RT; (vi) Hg(OAc)₂ (1 eq.), DBU (5 eq.), DCM, 15min., RT; (vii) PPh₃ (3 eq.), AcOCHO (3 eq.), propylene oxide (10 eq.), DCM, 24h., RT then Hg(OAc)₂ (3 eq.) then DBU (5.5 eq.); (viii) LiOH (1.1 eq.), THF:H₂O 4:1 then H₃O⁺; (ix) Tf₂O (1.5 equiv.), ⁱPr₂EtN (6 equiv.), DCM, 30min., -78°C.

Scheme 43

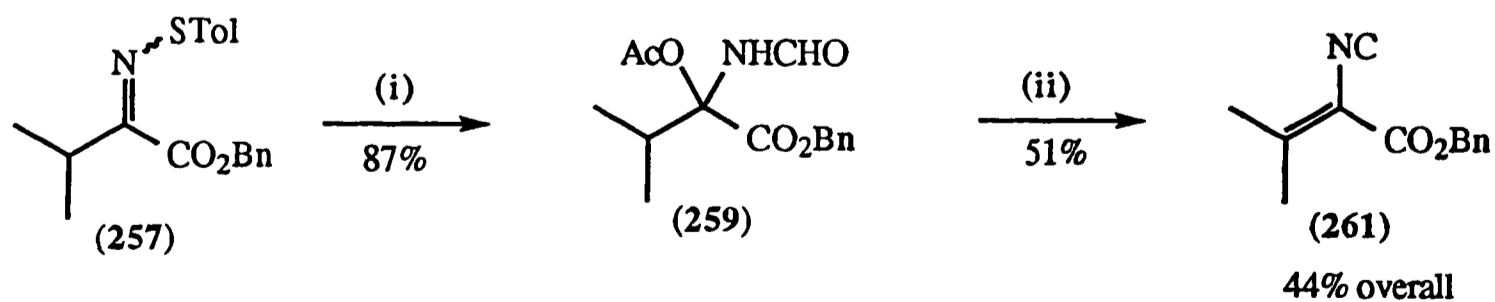

(i) PPh₃ (3 eq.), AcOCHO (3 eq.), Hg(OAc)₂ (3 eq.), DCM, 24h., RT; (ii) DBU (1.1 eq.), RT, 30min. then Tf₂O, (1.5 eq.), DBU (5 eq.), DCM, 20min., -78°C.

Scheme 44

3.3.4 Preliminary Studies Towards the Synthesis of a Biologically Active Analogue of Antibiotic A-32390A

Due to time constraints it was decided to apply the modified methodology to a total synthesis of (249), an analogue of (18), rather than to the natural product itself. This decision was taken on the basis that it would allow for a more rapid examination of the isonitrile chemistry. Furthermore this analogue shows comparable biological activity to A-32390A against a variety of bacterial strains.²¹⁶ Retrosynthetic analysis is shown, Scheme 45.

Thus (249) was disconnected to the erythreitol fragment and two identical vinyl isonitrile portions. The stereochemistry of the central portion suggested it could be readily prepared from a suitable (*L*)-tartrate ester such as (269) whilst the vinyl isonitriles would be prepared as described above with the two portions coupled either as in Strategy 1 or Strategy 2, Scheme 45. In an attempt to address the first of the problems with Schöllkopf's synthesis (*i.e.* the protecting group strategy), *vide supra*, silyl ethers were chosen as the hydroxyl protecting groups. Silyl ethers show stability over a wide range of conditions and in addition, their chemospecific removal with fluoride ion has been shown not to effect the isonitrile functionality.¹³¹ Thus diethyl-(*L*)-tartrate (269) was originally protected as its *bis*-TBDMS ether.²¹⁷ Unfortunately, all attempts to reduce the ester functionalities with either LiAlH₄ or DIBAL resulted in migration of the silicon protecting groups to the primary hydroxyls. Similar results were obtained with the TBDPS protecting group which has been reported to be virtually unaffected by a variety of conditions that lead to the cleavage of *O*-TBDMS, Scheme 46.²¹⁸

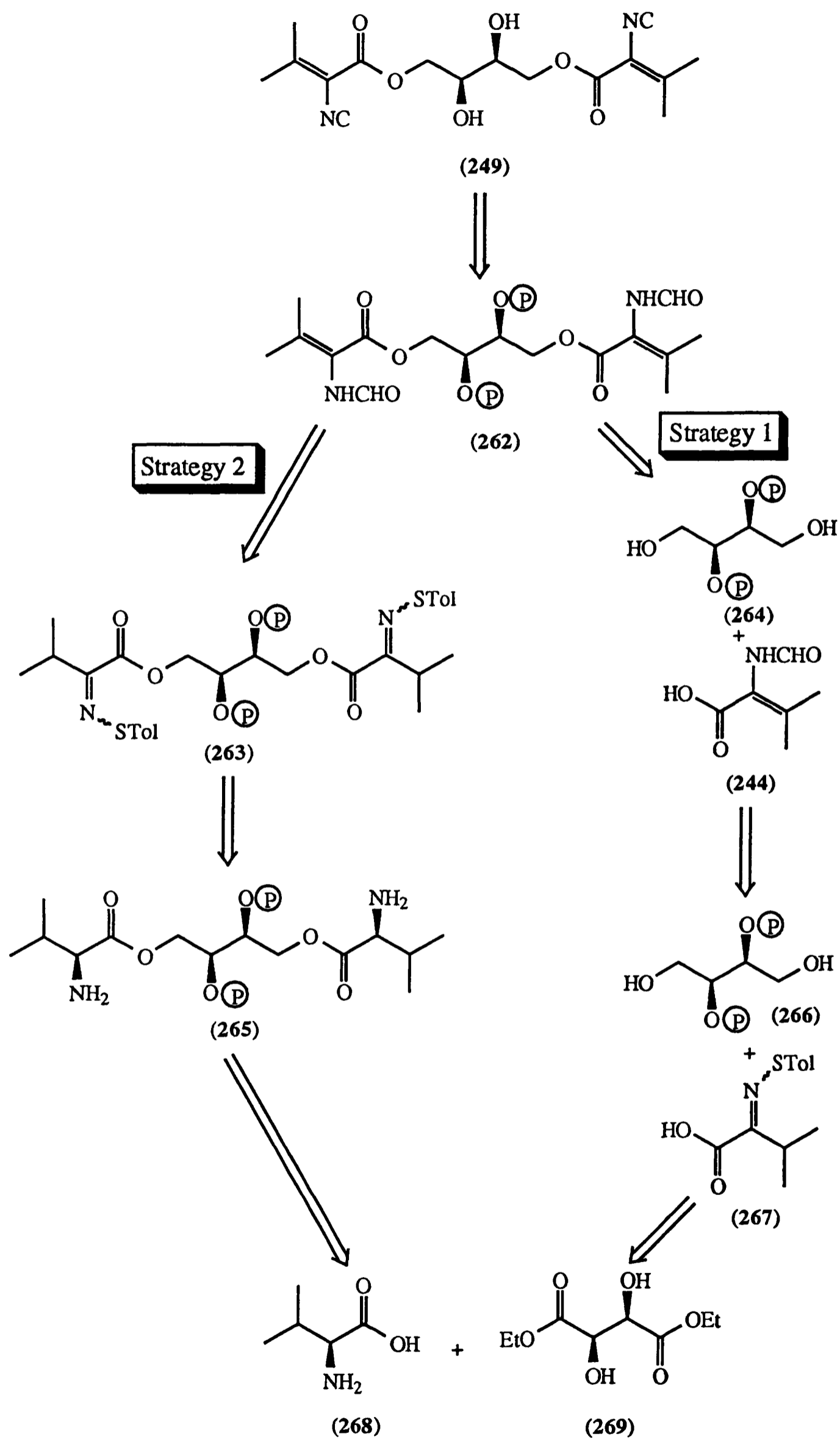

Scheme 45

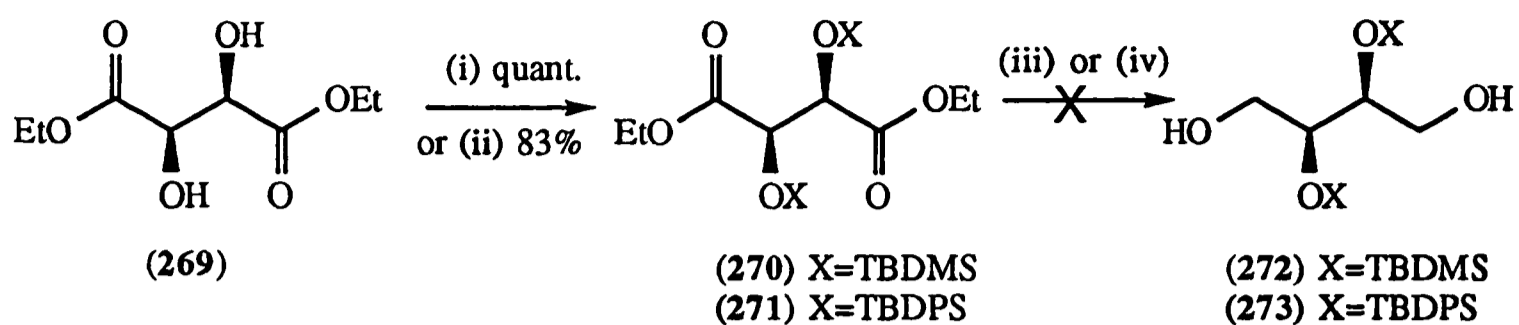

(i) TBDMSCl (2.4 eq.), imidazole (5 eq.), DMF, 35°C, 14h.; (ii) TBDPSCl (2.4 eq.), imidazole (5 eq.), DMF, 40°C, 40h.; (iii) LiAlH₄ (1.5 eq.), Et₂O, 0°C; (iv) DIBAL (4 eq.), Et₂O, 0°C.

Scheme 46

It was then decided to test the much more robust 2-(trimethylsilyl)ethoxymethoxy (SEM) ether as the hydroxyl protecting group.²¹⁹ The SEM group can also be selectively removed with fluoride ion but does not possess an oxygen-silicon bond and was therefore proposed to be stable to the reduction conditions and less likely to undergo migration. Thus the hydroxyl groups of diethyl-(*L*)-tartrate (269) were protected as *O*-SEM ethers in quantitative yield. Reduction of the ester groups of (274) then proceeded smoothly to generate the desired diprotected tetrol (275). At this point it was elected to attach the amino acid residues to the central portion *i.e.* to follow Strategy 2, Scheme 45. This was designed to probe the thiooxime to vinyl formamide rearrangement in a more demanding environment. Thus, thiooxime (276) was prepared from (275) in three synthetic operations.

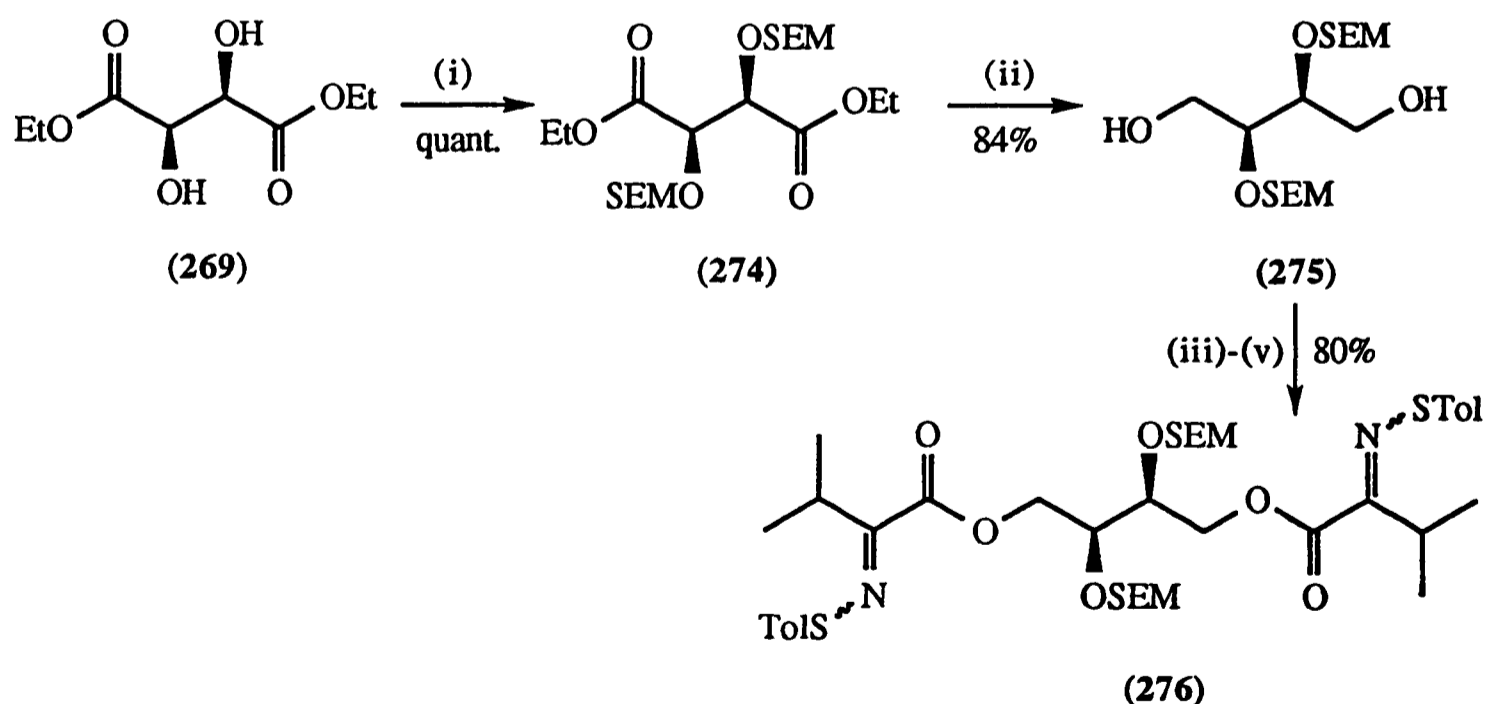

(i) SEMCl (4 eq.), ⁱPr₂EtN (9 eq.), 35°C, 24h.; (ii) LiAlH₄ (1.5 eq.), Et₂O, 0°C; (iii) (*L*)-*N*-Z valine (2.1 eq.), DCC (2 eq.), DMAP (0.2 eq.), DCM, 20h., RT; (iv) H₂, 10% Pd/C, EtOAc; (v) *p*-TolSCl (6 eq.), propylene oxide, 4Å mol. sieves, DCM, 3h., RT.

Scheme 47

Due to problems associated with the isolation of the α -acetoxy formamide or vinyl formamide (278) directly from the rearrangement reaction, (278) was prepared in reasonable overall yield from (276) *via* the α -thioformamide (277) in two steps. The efficacy of triflic anhydride as a dehydrating agent on this system was demonstrated, with a good yield of 70% of vinyl isonitrile (279) being achieved. Unfortunately, however, it was not possible to effect cleavage of the SEM ethers of (279) with either TBAF or CsF in order to obtain the target material (249), Scheme 48. Instead decomposition occurred, with only diol (275) being isolated from the reaction mixture, presumably as a result of hydrolysis of the ester linkages by residual water in the fluoride sources. In keeping with previous indications in the literature it was proposed that the increased stability of the SEM groups was preventing observation of the desired product due to competing decomposition of the sensitive ester moiety.²²⁰ At this time these results did not preclude the potential of using fluoride deprotection of a more labile silicon-based protecting group.

3.4 Completion of the Synthesis of a Biologically Active Analogue of Antibiotic A-32390A

Clearly, in order to achieve a total synthesis of (249), a more labile protecting group for the secondary hydroxyls would be required. For the reasons given above the TBDMS group was preferred. In addition its use would allow recourse to an acid mediated deprotection of earlier intermediates. The formation of the diprotected tetrol (272) was, therefore, re-investigated. In 1991, a reaction carried out by Parry during studies on the biosynthesis of the novel amino acid *trans*-(+)-(*S*)-1-propenyl-(*L*)-cysteine sulfoxide was noted.²²¹ The alcohol (282) had been prepared by reduction of the methyl ester of (281) with lithium triethylborohydride (Super-Hydride[®]) without migration of the TBDPS group to the alternative primary hydroxyl, Scheme 49.

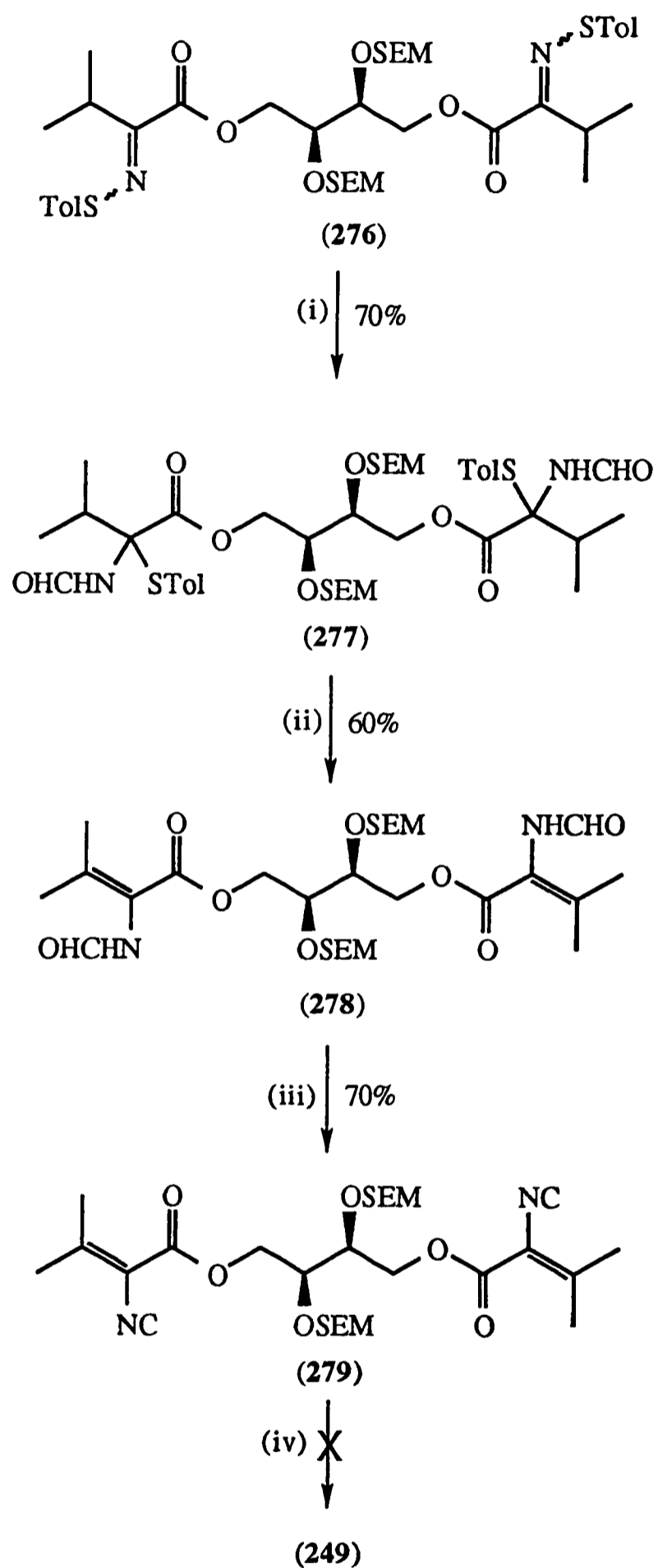

(i) AcOCHO (6 eq.), PPh₃, (6 eq.), propylene oxide, DCM, RT, 48h.;
 (ii) DBU (5 eq.), DCM, RT, 24h.; (iii) Tf₂O, (3 eq.), ^tPr₂EtN (12 eq.),
 DCM, RT, 30min.; (iv) TBAF or CsF.

Scheme 48

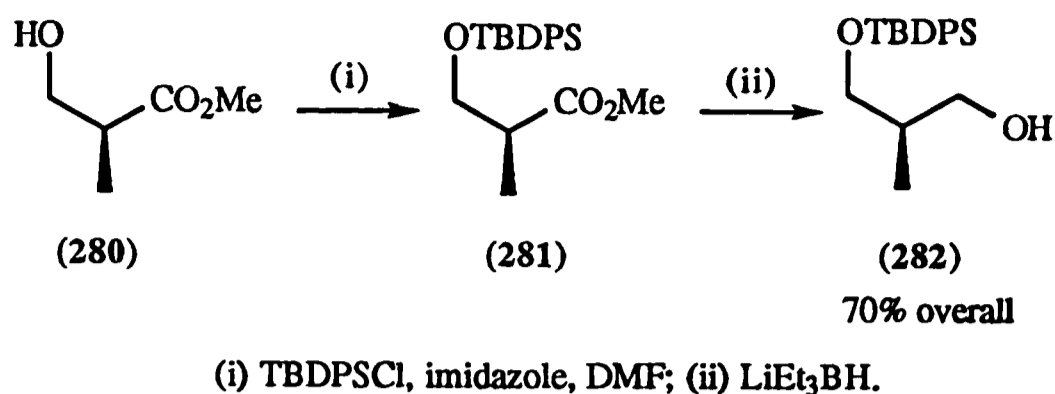

Scheme 49

The use of this reagent in the formation of (249) was therefore examined. No experimental details appeared in Parry's report, but after some optimisation a 70% yield of (272) from (270) was achieved using six equivalents of lithium triethylborohydride, Scheme 50. Essential to the success of the reaction was the rapid work-up with hydrochloric acid which doubtless prevented formation of non-boron alkoxides in the mixture. The yield was reduced on scale-up as, in order to avoid an uncontrollable exotherm, acid could not be added sufficiently rapidly to avoid side reactions. The high strength of the O-B compared to the O-Al bond presumably imposed a kinetic barrier to migration and the large size of the triethylboron moiety may also contribute to this group preferring to be at the terminus.

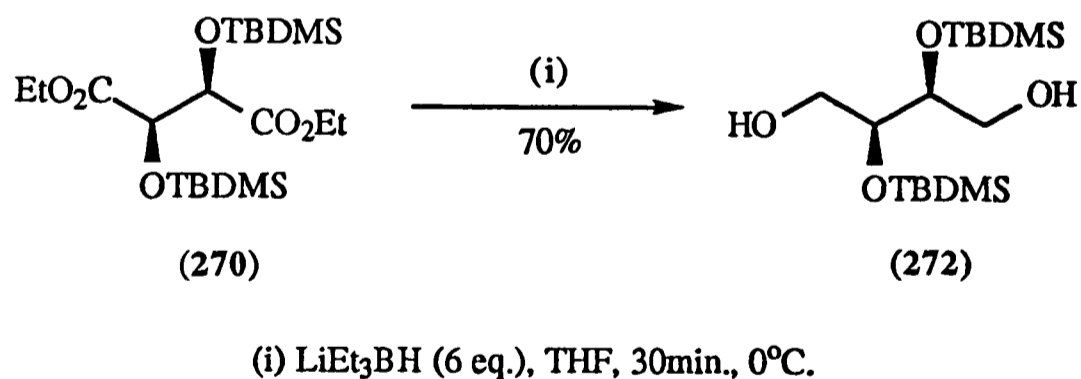

Scheme 50

A DCC/DMAP mediated coupling between diol (272) and (*L*)-*N*-Z protected valine afforded (283) in quantitative yield.²²² Although the sp³ chiral centre from the amino acid would be converted to an achiral sp² centre at a later stage, homochiral valine was utilised in order to maintain the C₂ symmetry of (283), leading to a substantial simplification of the n.m.r. spectra. Hydrogenolysis of the *N*-Z group proceeded smoothly and in quantitative

yield. The resulting diamine (**284**) was converted to *bis*-thiooxime (**285**) (present as a mixture of isomers) in 87% yield by treatment with six equivalents of *p*-tolylsulfenylchloride in the presence of 4Å molecular sieves and propylene oxide.¹⁵⁴ It is interesting to note that despite the fact that two reactions are being carried out at each stage (at either end of the molecule) high yields are obtained for all these synthetic transformations, Scheme 51.

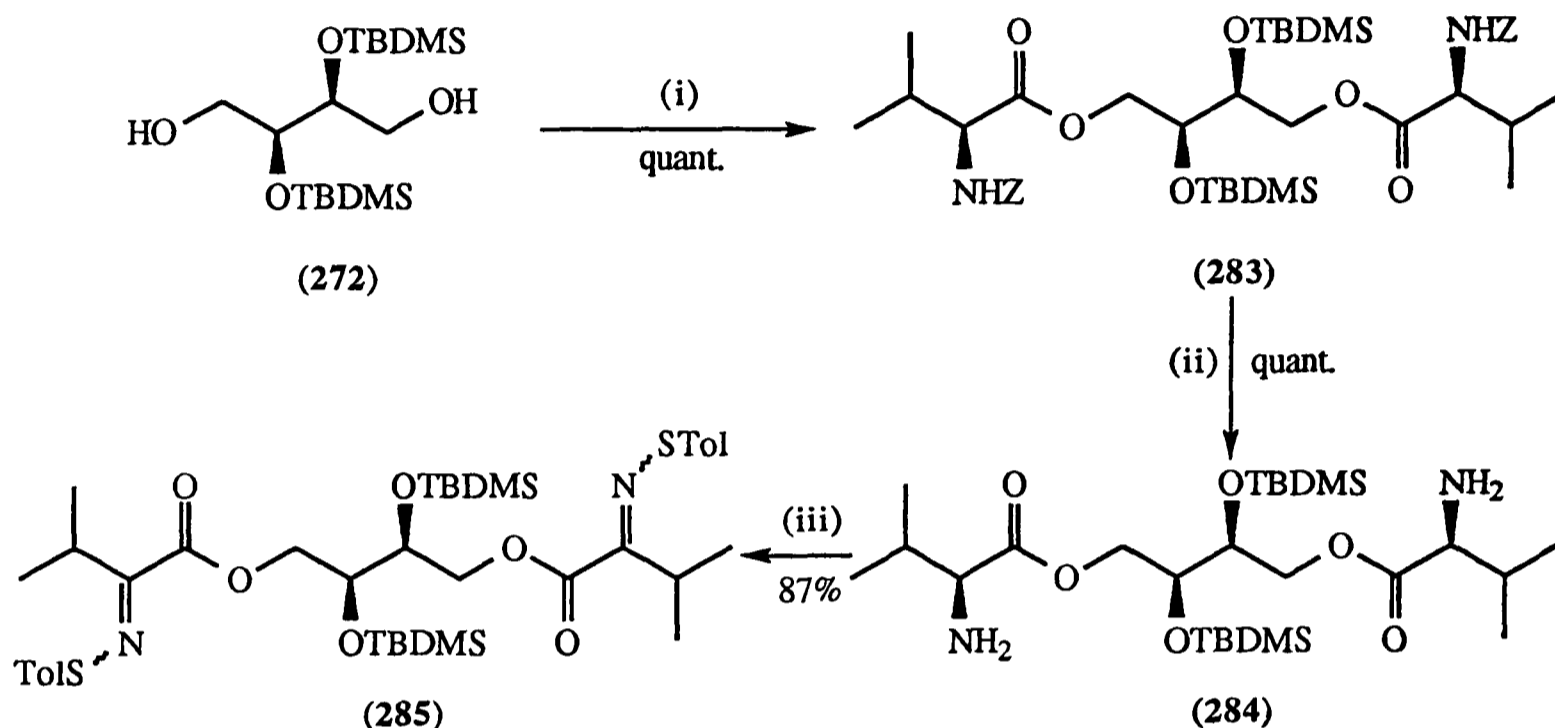

(i) (*L*)-*N*-*Z*-valine (2.1 eq.), DCC (2.1 eq.), DMAP (0.2 eq.), DCM, 24h., RT;

(ii) H₂, 10% Pd/C, EtOAc;

(iii) *p*-TolSCl (6 eq.), propylene oxide (100 eq.), 4Å mol. sieves, DCM, 3h., RT.

Scheme 51

The rearrangement of the thiooxime (**285**) to the α -acetoxy formamide (**286**) was then attempted according to the most efficient route for the model system, Scheme 44. After treatment of (**285**) with acetic formic anhydride, PPh₃ then Hg(OAc)₂ the crude ¹H n.m.r. indicated that the desired α -acetoxy intermediate (**286**) had indeed formed. Unfortunately silica gel chromatography led to complete decomposition. To solve this problem by avoiding the isolation of this sensitive intermediate an *in situ* elimination to deliver vinyl formamide (**287**) was then effected. Unfortunately this very polar compound co-eluted with triphenylphosphine oxide, a by-product of the reaction, in a variety of solvent systems and therefore could not be purified, Scheme 52.

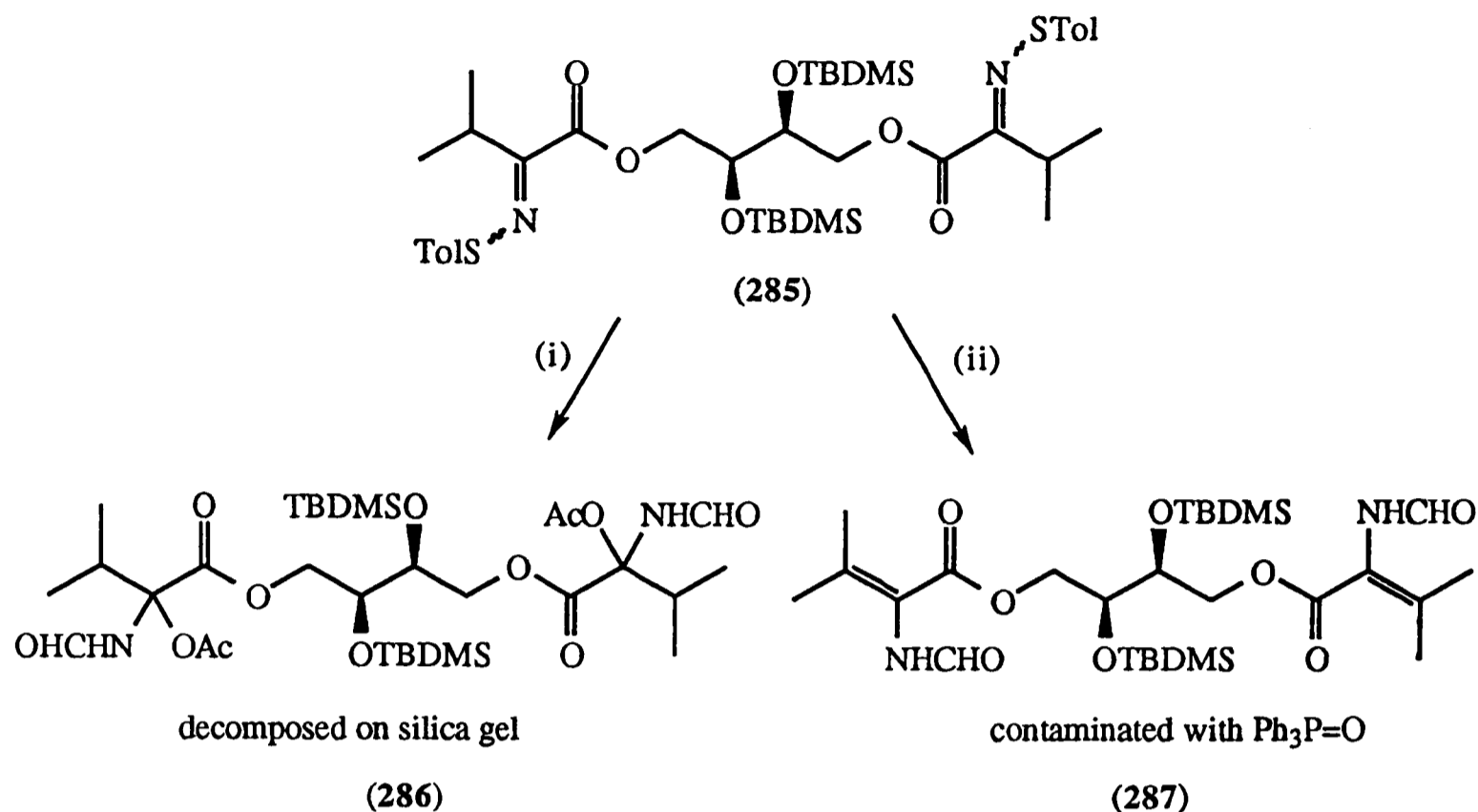

(i) PPh_3 (6 eq.), AcOCHO (6 eq.), propylene oxide (20 eq.), DCM , 24h., RT, then $\text{Hg}(\text{OAc})_2$ (2 eq.), RT;
 (ii) PPh_3 (6 eq.), AcOCHO (6 eq.), propylene oxide (20 eq.), DCM , 24h., RT then $\text{Hg}(\text{OAc})_2$ (2 eq.), then DBU (5 eq.), RT.

Scheme 52

Two different strategies were then investigated in an effort to obtain pure compound (287). In the first of these potential solutions, attempts were made to isolate the α -thioformamide (288) by performing the rearrangement in the absence of $\text{Hg}(\text{OAc})_2$ as the α -thioformamide was thought less likely to undergo decomposition on silica gel. Unfortunately work-up after twenty-four hours gave the α -acetoxy compound as the major product. The yield of the α -thioformamide was low (15%). However, it was found that by performing the reaction under more concentrated conditions and allowing the reaction to proceed for sixty hours rather than the usual twenty-four hours, all the α -acetoxy formamide was converted to the α -thioformamide (288). This led to an isolated yield of 74% of the α -thioformamide (288). Elimination with DBU was found to be more facile than in the model system and afforded the vinyl formamide (287) in a reasonable yield (75%) giving an overall yield from (285) of 56%, Scheme 53.

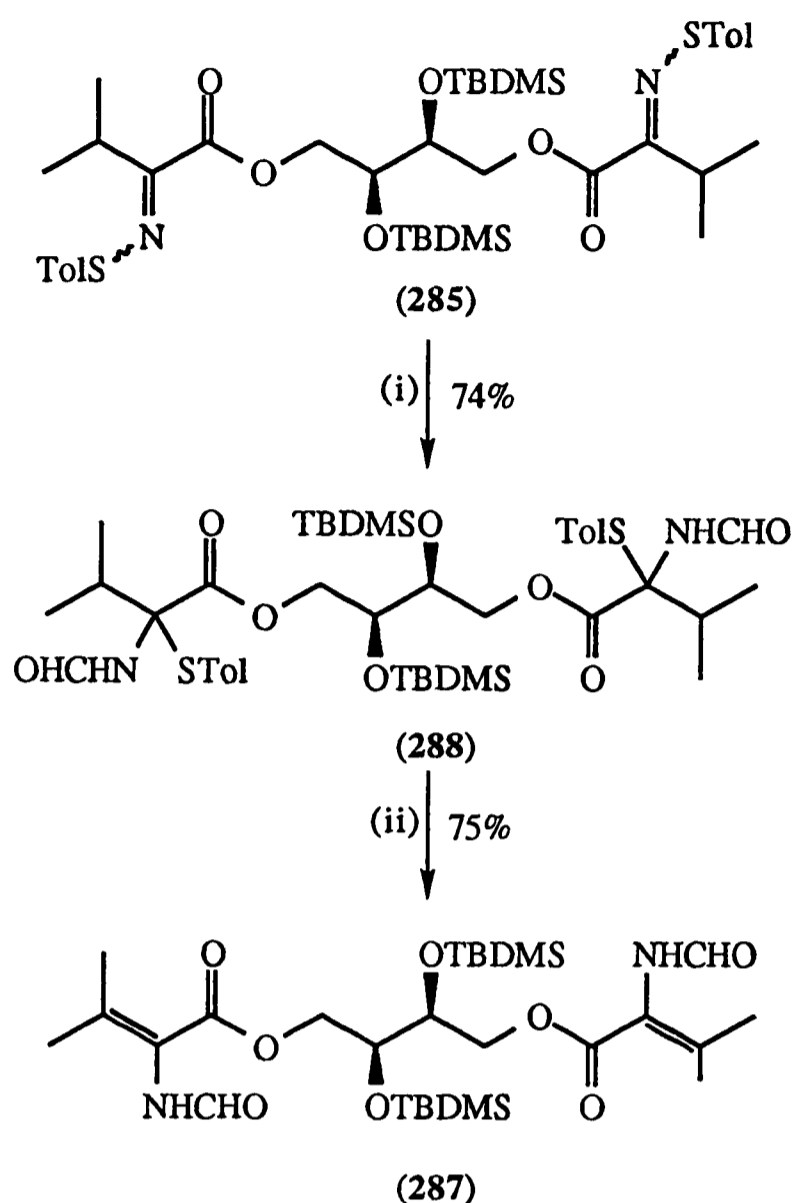

(i) PPh_3 (6 eq.), AcOCHO (6 eq.), propylene oxide (20 eq.), DCM, 60h., RT;
(ii) DBU (5 eq.), DCM, 24h., RT.

Scheme 53

In the second solution to obtaining chromatographically homogenous (287), polymer supported phosphine was investigated. Functionalised polymers have recently found widespread application in organic synthesis where they have been used as reagents, catalysts, protecting groups and substrate carriers. One of the most important advantages in using a functionalised polymer as a reagent or catalyst is the simplification of work-up, separation and isolation.²²³ In 1992, polymer supported triphenylphosphine²²⁴ (a polystyrene cross linked with 2% DVB) became commercially available. It was hoped that the practical problem of obtaining clean (287) directly from (285), Scheme 54, could be overcome by the substitution of PPh_3 by this polymer-supported reagent. After stirring (285) with polymer supported PPh_3 and acetic formic anhydride for twelve hours, t.l.c. analysis indicated a mixture of α -thioformamide (288) and α -acetoxy formamide (286). Filtration to remove the

polymer was followed by the sequential addition of $\text{Hg}(\text{OAc})_2$ and DBU. Silica gel chromatography afforded the vinyl formamide (**287**) as a crystalline solid in a 62% yield from (**285**).

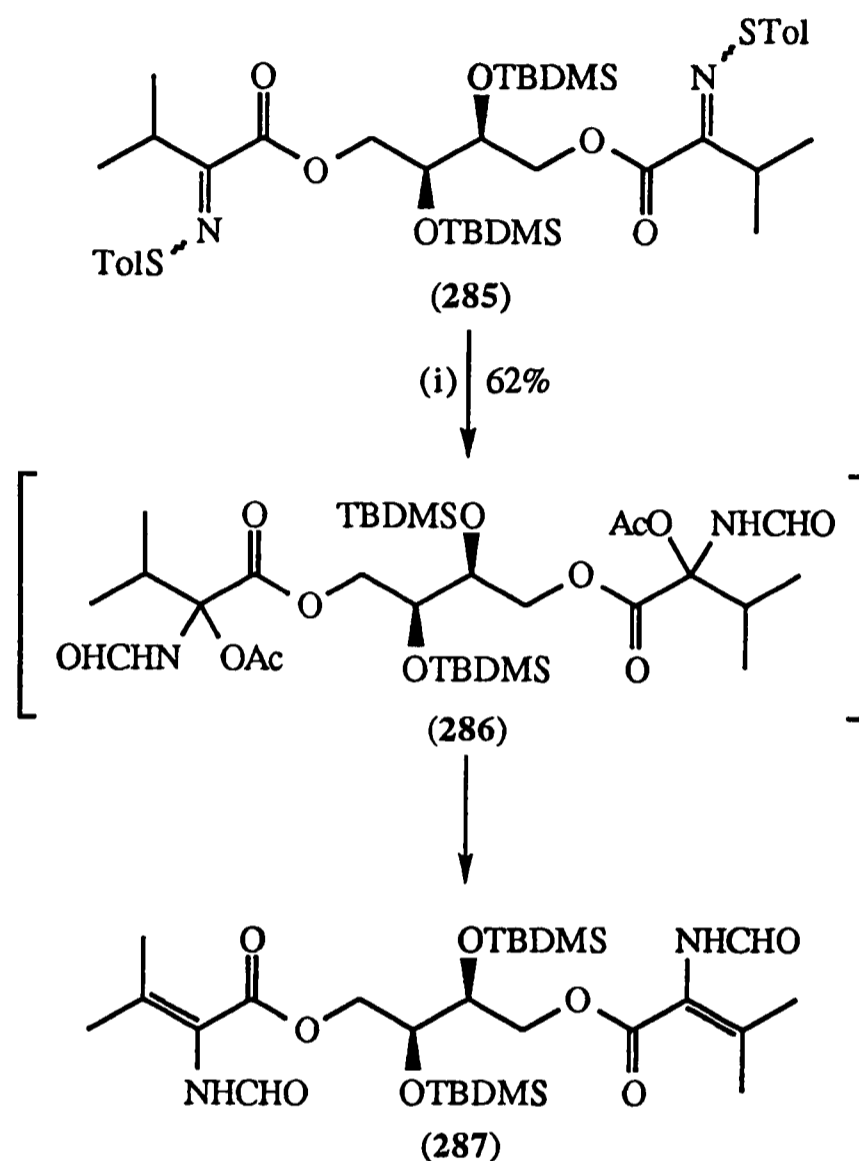

(i) polymer supported PPh_3 (6 eq.), AcOCHO (6 eq.), propylene oxide (20 eq.), DCM, 12h. then $\text{Hg}(\text{OAc})_2$ (2 eq.), then DBU (5 eq.), RT.

Scheme 54

Dehydration of (**287**) was effected in good yield with triflic anhydride in the presence of *N,N*-diisopropylethylamine to afford vinyl isonitrile (**289**), Scheme 55.¹³⁰ Unfortunately, attempts to deprotect (**289**) to generate (**249**) proved unsuccessful with decomposition resulting on treatment with TBAF or CsF. Despite the greater lability of *O*-TBDMS compared to *O*-SEM and attempts to remove residual water from these fluoride sources, the extreme lability of the ester functionalities to base catalysed hydrolysis could not be overcome.

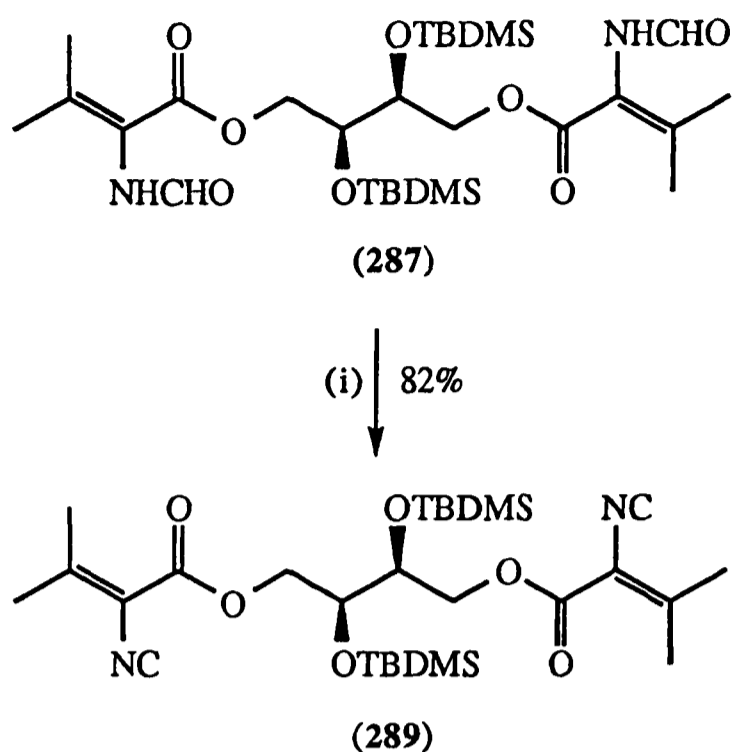

(i) Tf_2O (2 eq.), ${}^i\text{Pr}_2\text{EtN}$ (12 eq.), DCM, 30min., -78°C .

Scheme 55

Ammonium fluoride in methanol has recently been reported to desilylate nucleosides *e.g.* (290) and (291), Figure 13.²²⁵ The ability of this reagent to deprotect these alcohols is remarkable considering the authors report that normally the 'naked' fluoride ion is required. It has been proposed that the weakly acidic ammonium ion participates in hydrogen bonding to the ether oxygen during nucleophilic attack on silicon by the fluoride counter anion, Scheme 56. Due to the acidic rather than basic nature of this reagent it was hoped its use with (289) would overcome the ester hydrolysis problem. The reaction of (289) with NH_4F was, however, extremely slow and led to a large number of unidentifiable products.

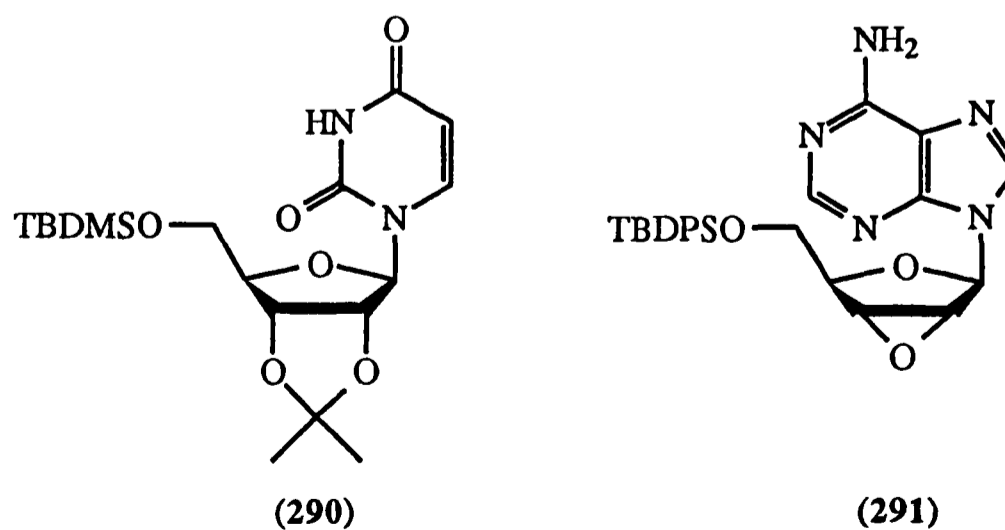
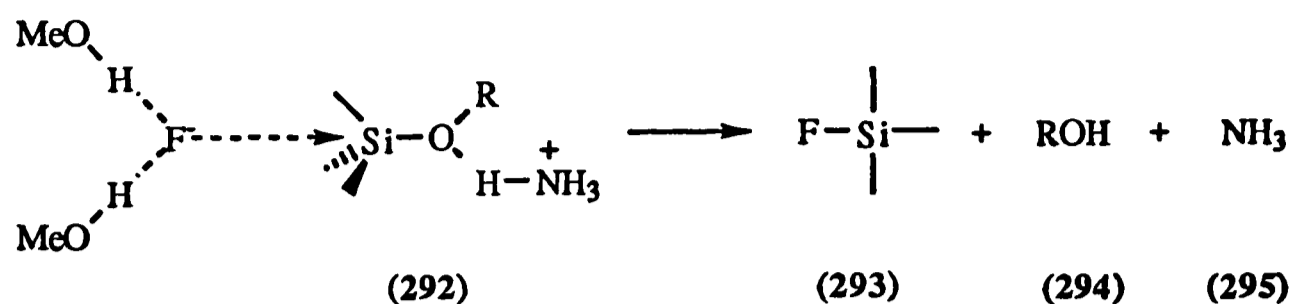
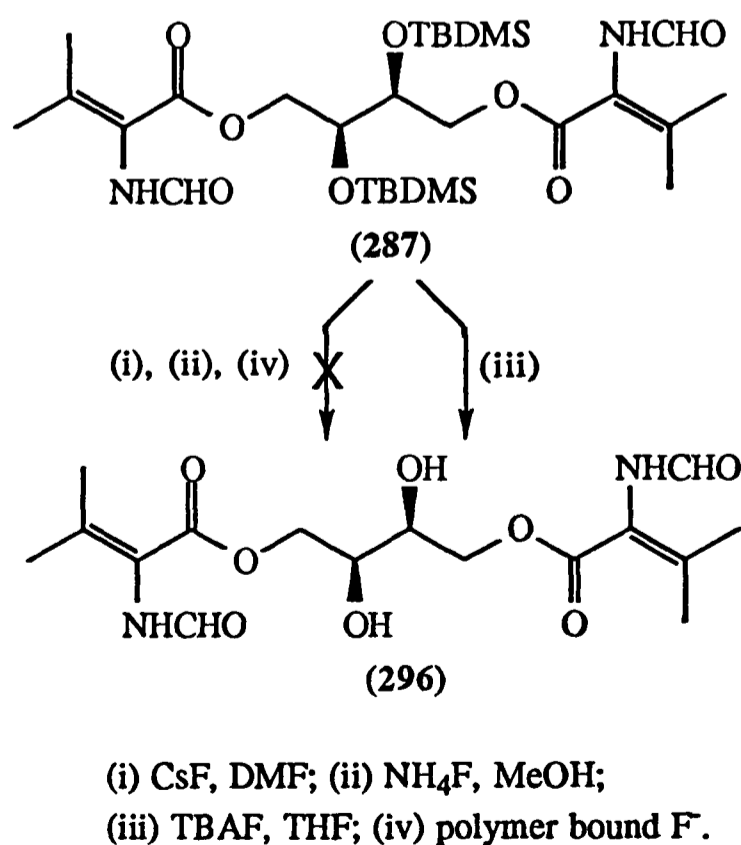

Figure 13



Scheme 56

The possibility of deprotection at the vinyl formamide stage was then examined. Initial attempts were made using CsF which lead to decomposition. However, with TBAF in THF the ^1H n.m.r. of the crude reaction mixture indicated that some of the desired product was being generated but unfortunately the phase transfer properties associated with the tetrabutylammonium cation precluded the separation of the highly polar diol (296) from the reaction by-products. In an attempt to address this point, ammonium fluoride in methanol was used, however, no reaction was observed with this reagent, Scheme 57. The use of a polymer bound fluoride source Amberlyst A-26 (F⁻ form), was then investigated since this has been shown to successfully deprotect silylated sugars, Scheme 58.²²⁶ Unfortunately when (287) was reacted with the resin bound fluoride, using the literature protocol, decomposition resulted, Scheme 57.



Scheme 57

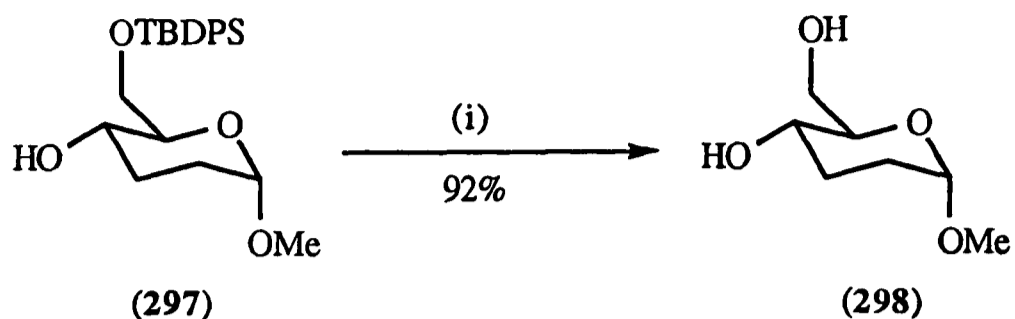

(i) Amberlyst A-26 (F⁻), reflux, benzene, 4h.

Scheme 58

Schöllkopf had utilised formic acid in the removal of benzylidene groups at this stage of his synthesis and, as the acid catalysed cleavage of *O*-TBDMS groups is well established, the possibility of using this reagent in the removal of the silicon groups of (287) was examined.²¹⁰ Heating (287) with 90% formic acid at 50°C for one hour gave a good yield (80%) of (296) after recrystallisation from acetone. An excellent quantitative yield of the crystalline diol (296) could, however, be achieved by stirring at room temperature for four hours and simply removing the by-products *in vacuo*.

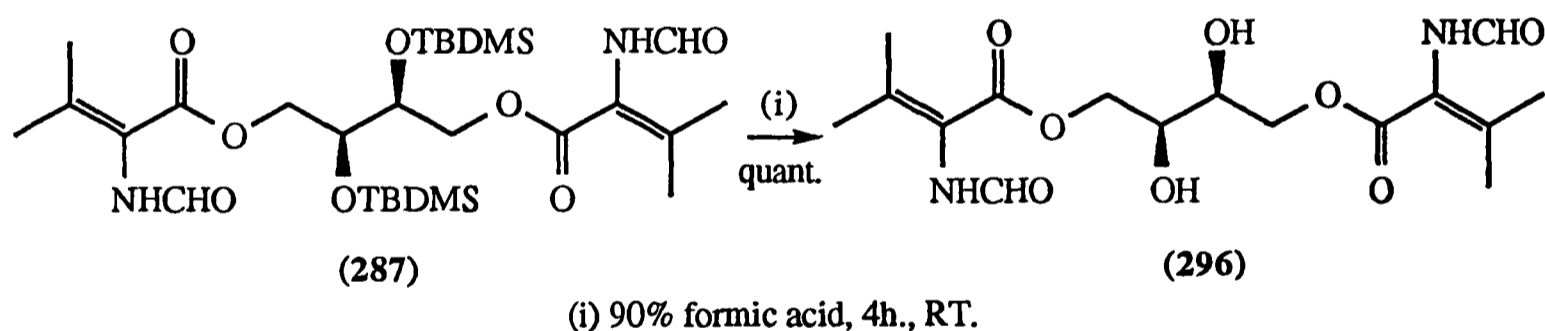

Scheme 59

As the diol (296) had been prepared previously by Schöllkopf this represented a formal total synthesis at this stage. With (296) in hand, the task of improving the final stages of the synthesis of (249) was undertaken.

Many reagents which effect dehydration of primary amides to nitriles also dehydrate formamides to isonitriles and in 1988 Claremon reported an efficient method for the preparation of nitriles from primary amides using methoxy(carbonylsulfamoyl) triethylammonium hydroxide inner salt (Burgess reagent) as the dehydrating agent.²²⁷ The

chemospecificity of the reagent was demonstrated on a number of multi-functionalised molecules including (299) which possesses free secondary hydroxyl groups, Scheme 60. The mechanism proposed for this dehydration is shown in Scheme 61.

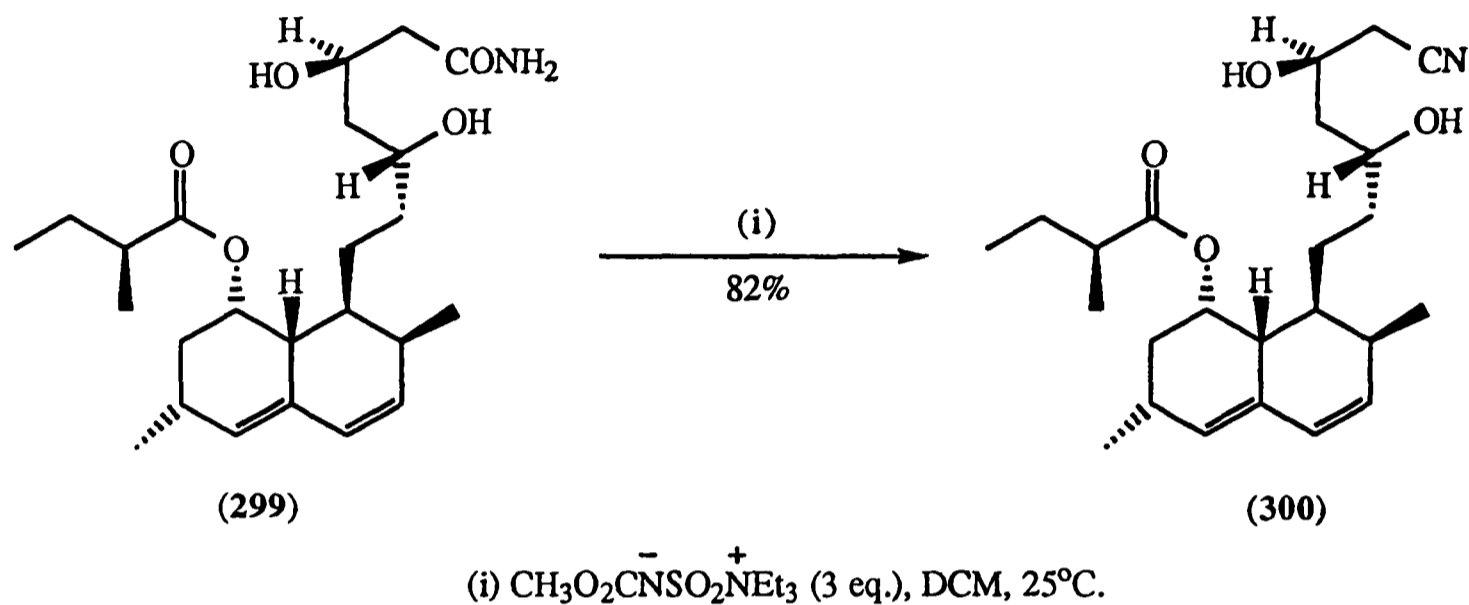

Scheme 60

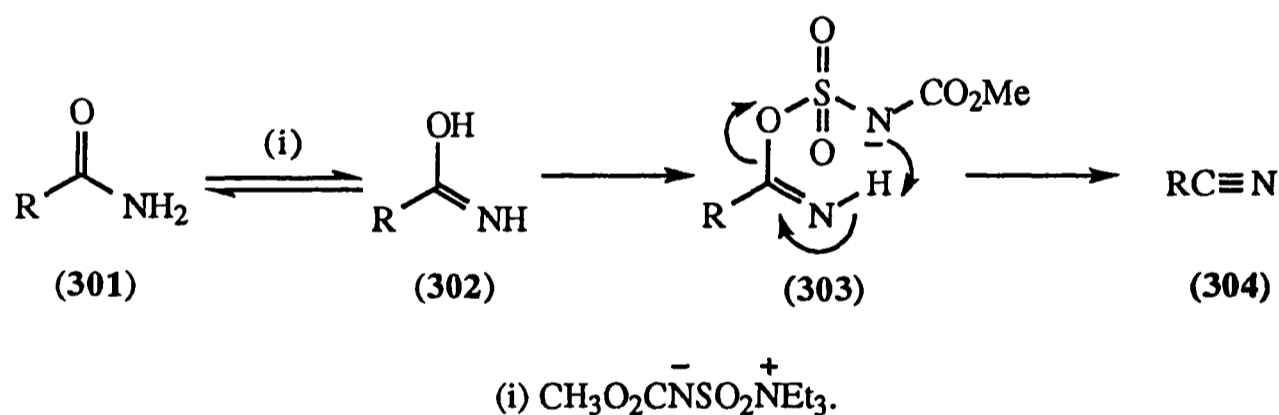

Scheme 61

The direct dehydration of (296) to the target material (249) was therefore a possibility with this reagent. The ability of this reagent to dehydrate simple vinyl formamides, Scheme 62, had been demonstrated by Dr. A.T. Russell.²²⁸ Its efficacy with α -carboxy systems was first tested on the SEM protected vinyl formamide (278) leading to a reasonable 56% yield of (279) with seven equivalents of Burgess reagent in pyridine. Attempted dehydration of (296), however, led only to decomposition, Scheme 63.

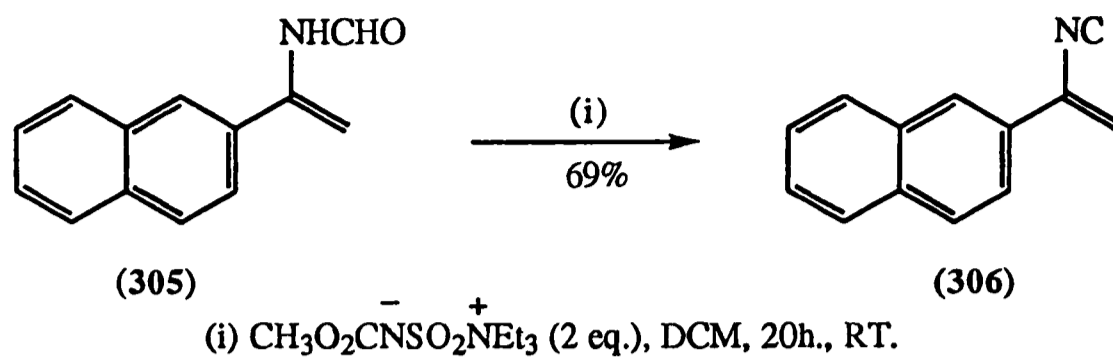

Scheme 62

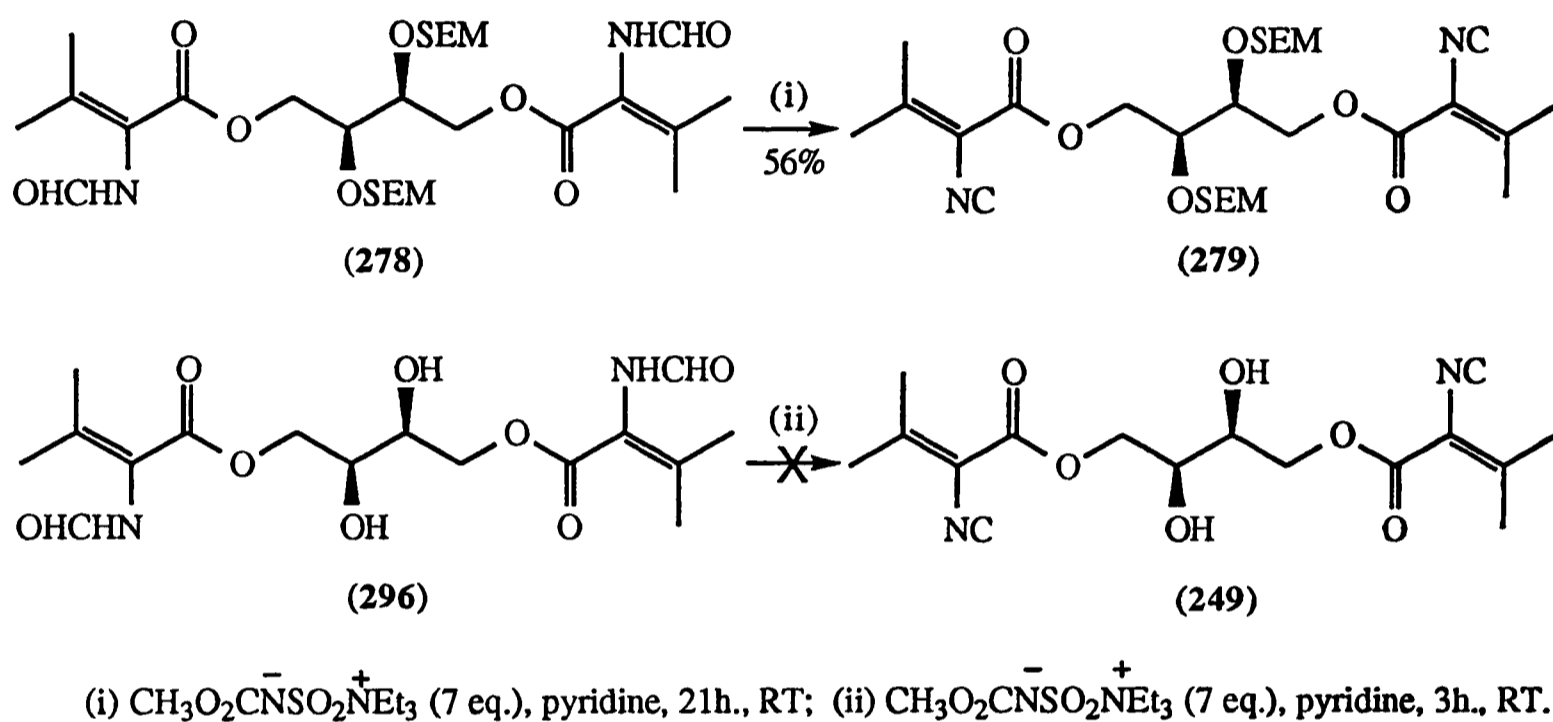

Scheme 63

Campagna has observed that trifluoroacetic anhydride leads to the rapid conversion of primary amides or aldoximes to nitriles.²²⁹ It was hoped that the treatment of (296) with this reagent in the presence of base would simultaneously protect the hydroxyls as their trifluoroacetate esters and dehydrate the formamide groups. Trifluoroacetate esters are readily hydrolysed and it was anticipated that this could be effected in the presence of the isonitrile groups to generate (249). Again, there existed no precedent for trifluoroacetic anhydride being used as a dehydrating agent for formamides and so initial reactions were carried out with benzyl ester (260). Treatment of (260) with an excess of trifluoroacetic anhydride in the presence of *N,N*-diisopropylethylamine resulted in a colour change consistent with dehydration having taken place, but only vinyl formamide (260) was recovered after work-up. The more reactive mixed anhydride of trifluoroacetic acid and triflic acid

(CF₃SO₂OCOCF₃),²³⁰ which also acts as a trifluoroacetylating agent, was then examined in the presence of *N,N*-diisopropylethylamine but again only starting material was recovered, Scheme 64. Finally, these reactions were monitored by ¹H n.m.r. The addition of either trifluoroacetic anhydride or the mixed anhydride to a mixture of (260) and base was accompanied by the rapid and complete loss of the signals associated with (260) and the appearance of other signals, including one at 9.3 p.p.m., which did not correspond to the vinyl isonitrile (261). On work-up vinyl formamide (260) was recovered. It appears, therefore, that (260) reacts with the trifluoroacetylating reagents to generate adduct (307) (signal at 9.3 p.p.m. being proton H_a, Figure 14) which, as a result of the poorer leaving group ability of trifluoroacetate compared to triflate, does not undergo elimination to the vinyl isonitrile but on work-up is hydrolysed back to the formamide.

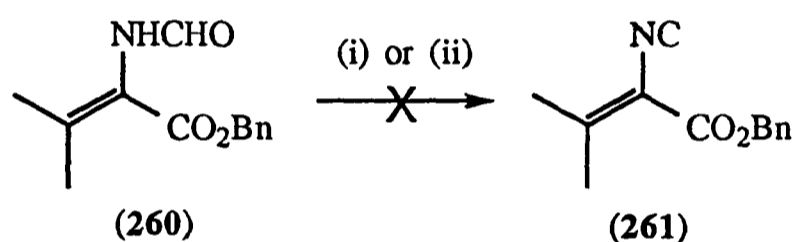

- (i) CF₃CO₂COCF₃ (2 eq.), *i*Pr₂EtN (6 eq.), DCM, -78°C to RT;
(ii) CF₃SO₂OCOCF₃ (2 eq.), *i*Pr₂EtN (6 eq.), DCM, -78°C to RT.

Scheme 64

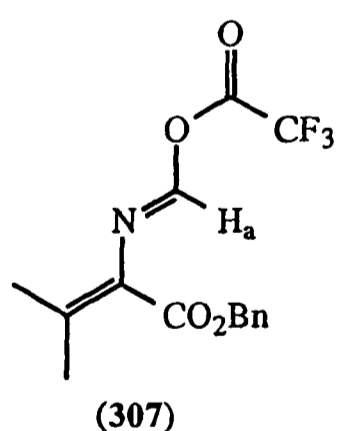
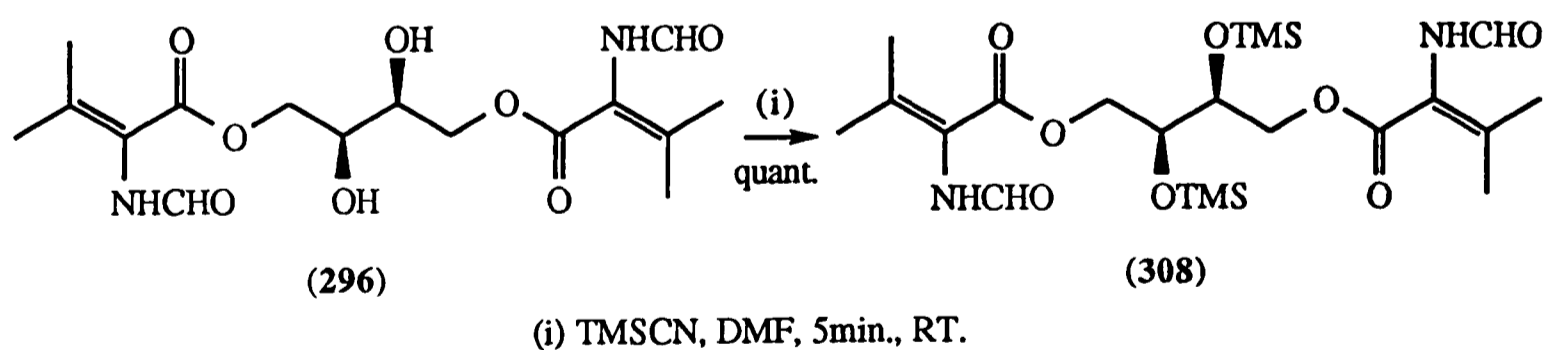

Figure 14

Hence it was decided to reprotect the hydroxyl groups prior to dehydration. Due to the base sensitivity of the ester groups and the acid sensitivity of the isonitrile functionality a protecting group that could be removed under mild conditions was required. For this reason the sensitive trimethylsilyl ether was chosen. Trimethylsilylation can be accomplished with a

large number of reagents that are commercially available. Two of the most widely used reagents, TMSCl and TMSOTf, rapidly silylate hydroxyl groups in the presence of a suitable base such as pyridine, Et₃N, imidazole or DBU but the resultant amine hydrochloride or triflate usually requires an aqueous work-up to ensure complete removal. A number of reagents have recently appeared in the literature, however, that bring about trimethylsilylation with the formation of only volatile by products which are easily removed, for example *N,O*-bis(trimethylsilyl)acetamide (by product *N*-trimethylsilylacetamide or acetamide)²³¹ and trimethylsilylcyanide (by-product HCN).²³² Our attention was drawn to the latter which was reported to readily silylate alcohols, phenols and carboxylic acids and, more slowly, thiols and amines but to not react with amides and related compounds. Thus, vinyl formamide (296) was dissolved in the minimum quantity of DMF and treated with a large excess of TMSCN. Stirring for five minutes was followed by the removal of HCN and the remaining TMSCN by bubbling argon through the reaction mixture. In this way the protected vinyl formamide (308) was obtained cleanly in quantitative yield, Scheme 65. The short reaction time and rapid removal of the excess TMSCN is, however, critical to avoid reaction with the formamide. On the few occasions when this was observed it was possible to recover the starting material by hydrolysis of the product mixture with formic acid.



Scheme 65

Dehydration of (308) was effected in 80% yield using triflic anhydride in the presence of *N,N*-diisopropylethylamine, Scheme 66.¹³⁰

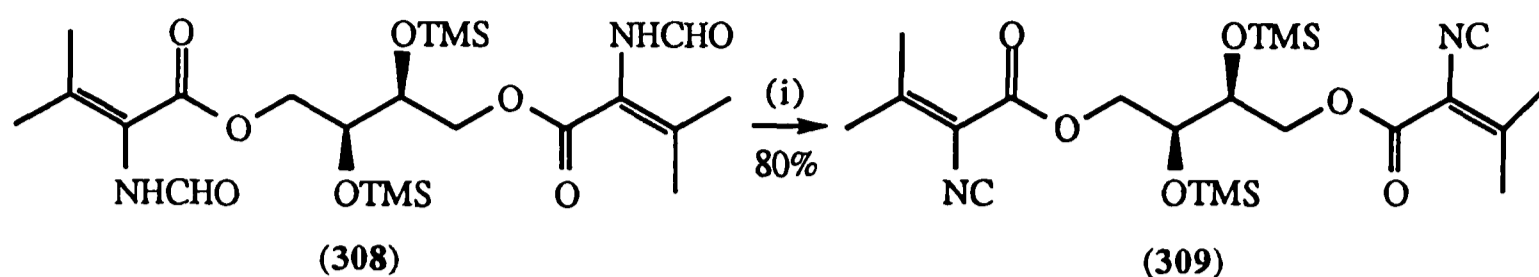

(i) TiF_2O (2 eq.), ${}^i\text{Pr}_2\text{EtN}$ (12 eq.), DCM, 30min., -78°C .

Scheme 66

Attempts to remove the TMS groups using mild base, namely K_2CO_3 in anhydrous methanol²³³ resulted in decomposition and no reaction was observed on stirring over mildly acidic silica gel for twenty-four hours. The acid catalysed hydrolysis of secondary TMS ethers using methanolic citric acid has been reported by Bundy during work on the synthesis of prostaglandin analogues.²³⁴ Indeed, very brief treatment of (309) with methanolic citric acid brought about desilylation without hydrolysis of the isonitrile functionalities to generate the target molecule (249) in 90% yield, Scheme 67.

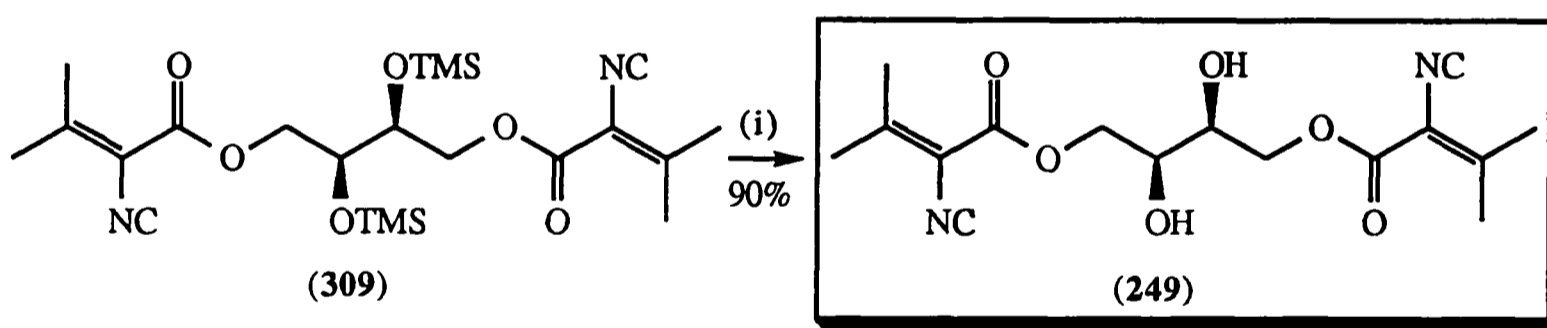

(i) methanolic citric acid, 15min., RT.

Scheme 67

3.5 Concluding Remarks

In conclusion, the Baldwin methodology for the preparation of vinyl formamides from thiooximes has been developed for use with α -carboxy systems and successfully applied to the synthesis of (249), a biologically active analogue of antibiotic A-32390A (18). In addition, triflic anhydride has been shown to be an effective reagent for the dehydration of vinyl formamides to vinyl isonitriles in these systems. The synthesis of (249) offers a shorter and, despite the linear strategy adopted, a higher yielding route to (249) than that of

Schöllkopf. (27% from (269) compared to 2.7% from (242)) using readily available starting materials.²³⁵ Furthermore, the methodology should be applicable to a synthesis of A-32390A where its use would allow the proposed biogenetic precursors of (18), namely valine and (*D*)-mannitol to be utilised as synthetic starting materials. A simple route to the protected diol is indicated in Scheme 68.²³⁶ Subsequent steps may then be carried out in an analogous manner to (249). Moreover, in terms of analogue synthesis such a strategy allows for a flexible entry into the natural and non-natural α -amino acid library.

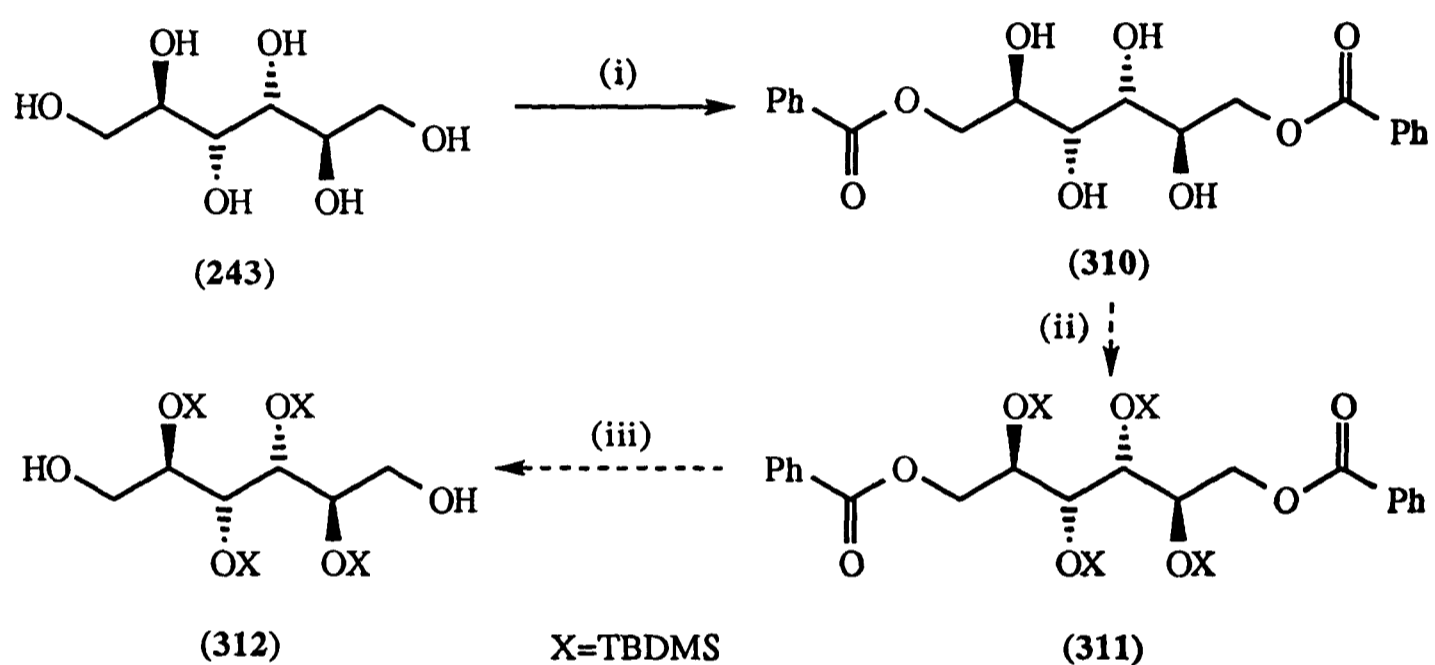

(i) PhCOCl, pyridine; (ii) TBDMSCl; (ii) LiEt₃BH.

Scheme 68

Chapter 4

The Synthesis of (\pm)-Isonitrin C (Trichoviridin)

4.1 The Isonitrins-Isolation and Biological Activity

Isonitrin C (or trichoviridin) was the first of the cyclopentyl isonitriles, obtained from the *Trichoderma* moulds, to be correctly characterised.¹ Its structure and absolute configuration were determined by Nobuhara *et al.* by X-ray analysis in 1975²⁸ (and re-elucidated several years later by Ollis *et al.*²⁹). Trichoviridin was thus determined to be an extremely complex, small molecule of structure (16), Scheme 69. Integrated onto a skeleton of seven carbon atoms are arranged six chiral centres and four functional groups including one, the epoxy isonitrile, which occurs extremely rarely in nature. The ¹H n.m.r. spectrum of trichoviridin has been assigned by Dr. A.E. Derome following n.O.e. experiments on the natural material and its mono-trifluoroacetyl derivative.²³⁷

Trichoviridin has been obtained from a large number of *Trichoderma* species but one of the best sources is *T. hamatum* which also produces the related metabolites, isonitrin A (14) and isonitrin B (or deoxytrichoviridin) (15). The structures of isonitrins A and B were originally determined by Fujiwara *et al.*²⁵ The structure of isonitrin B was, however, later revised by Baldwin following X-ray analysis.^{131,215} Figure 15 shows the dense packing of functionality on the almost flat five membered ring. Following this revision, it was postulated by Baldwin that, on biogenetic grounds, it would be more reasonable for the configuration of the exocyclic chiral centre of isonitrin A to be opposite to that assigned in the literature. N.O.e. studies on the natural material were consistent with this proposal, Figure 16.²³⁸

All three isonitrins exhibit antimicrobial activity. Isonitrin A has the broadest range of activity and the lowest inhibitory concentrations for all but one of the organisms against which they were screened.²⁵

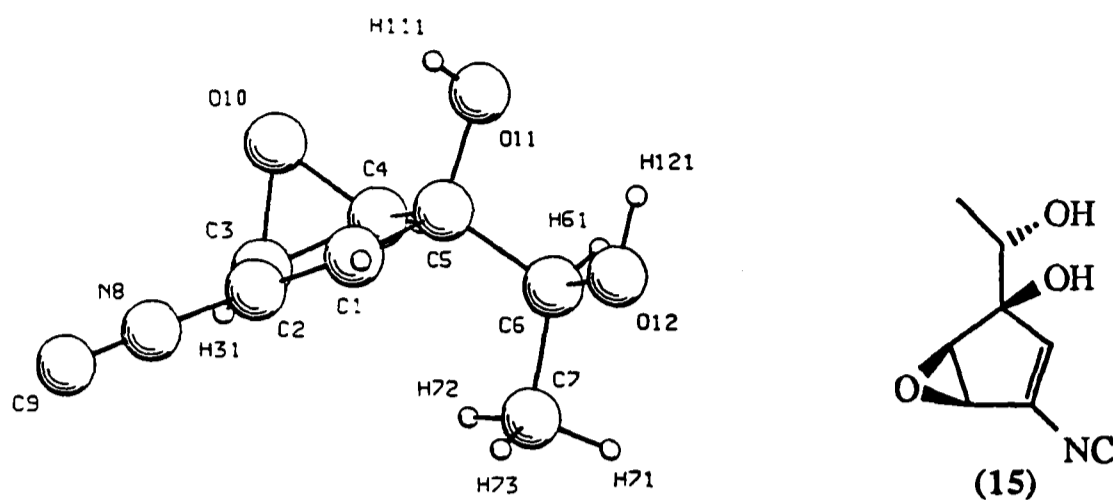

Figure 15

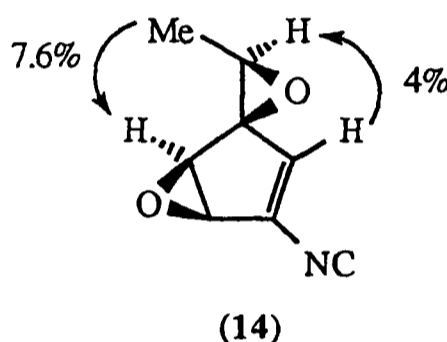

Figure 16

4.2 Synthetic Strategy for the Isonitrins-Retrosynthetic Analysis

The complex structures and biological activity of the isonitrins makes them interesting and challenging targets for synthetic organic chemists. Synthetic studies towards their preparation were initiated by the Baldwin group in Oxford in 1979, with Dr. A.E. Derome.²³⁷ The successful syntheses of isonitrins B and A were completed in 1989 and 1991 respectively.^{131, 238} Thus only the ultimate and most elusive goal, the synthesis of the most oxygenated of the isonitrins, trichoviridin, remained to be completed.

In the interests of flexibility and efficiency, when planning the syntheses of the isonitrins it had been proposed to adopt a divergent strategy whereby all three natural products would be prepared from a common intermediate of type (313) *i.e.* a vinyl formamide. This would be achieved by a combination of oxidative and dehydrative processes, Scheme 69. Preparation of vinyl formamide (313) from the amine (314) requires

a change in oxidation level in the ring. The epoxide (314) could be generated from directed epoxidation of alkene (315). Identification of the 1,3 relationship between the tertiary hydroxyl and nitrogen functionalities then revealed a [4+2] cycloaddition between acetylcyclopentadiene (318) and the acylnitroso dienophile (317) which would deliver the bicyclic adduct (316) after reduction of the ketone.

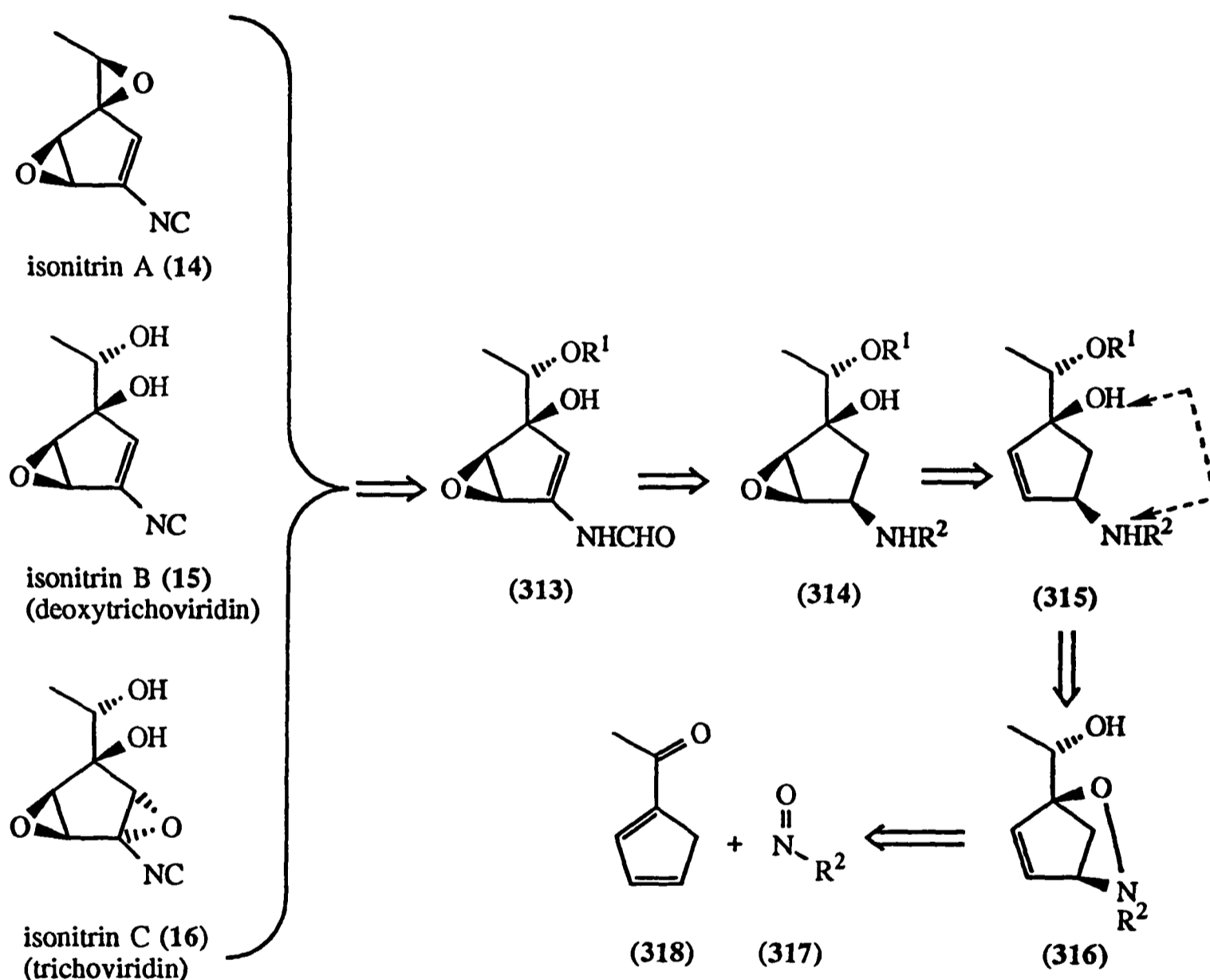

Scheme 69

4.3 Previous Synthesis of (±)-Isonitriin B (Deoxytrichoviridin)

Aldous and Chan had developed such a Diels-Alder strategy to generate the key intermediate (314) (R^1 =TBDMS, R^2 =Z), *vide infra*.²¹⁴ Baldwin's thiooxime to vinyl formamide rearrangement was then utilised by Aldous and O'Neil for the formation of vinyl

formamide (319), Scheme 72. The development of this new methodology was essential to the successful preparation of (319). Mild, neutral conditions are required to generate this vinyl formamide due to its instability toward acid, presumably as a result of the decomposition pathway shown in Scheme 71 which leads to elimination of the tertiary alcohol. For reasons discussed in section 4.5.2, (319) could not, however, be obtained chromatographically homogeneous which prevented its characterisation and hindered implementation of some further aspects of the synthesis.²¹⁵ It should be noted that in the successful synthesis of (15) the tertiary alcohol was left unprotected. A number of different protecting groups for this alcohol had been investigated without success, for example protection of the diol as the carbonate converted the tertiary alcohol to a better leaving group and resulted in an isomer of isonitrin B being formed. This was presumed to have resulted from epimerisation at the vinyl formamide stage, Scheme 71.²¹⁵

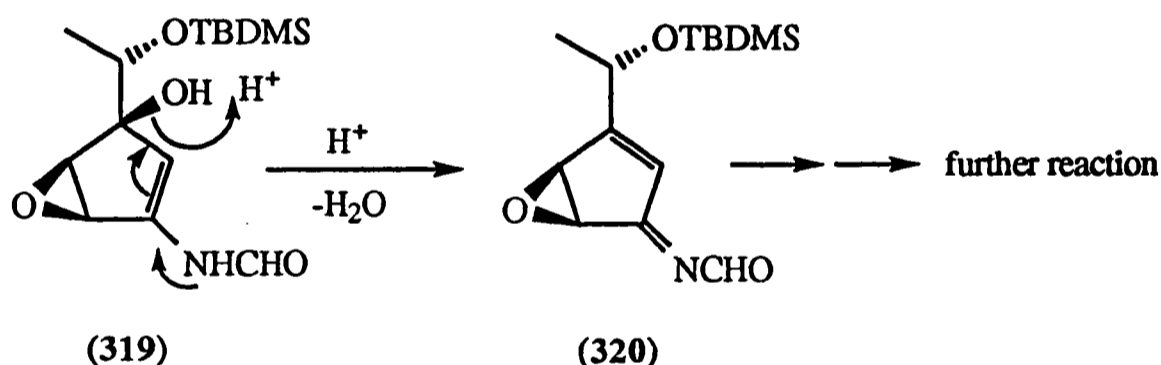

Scheme 70

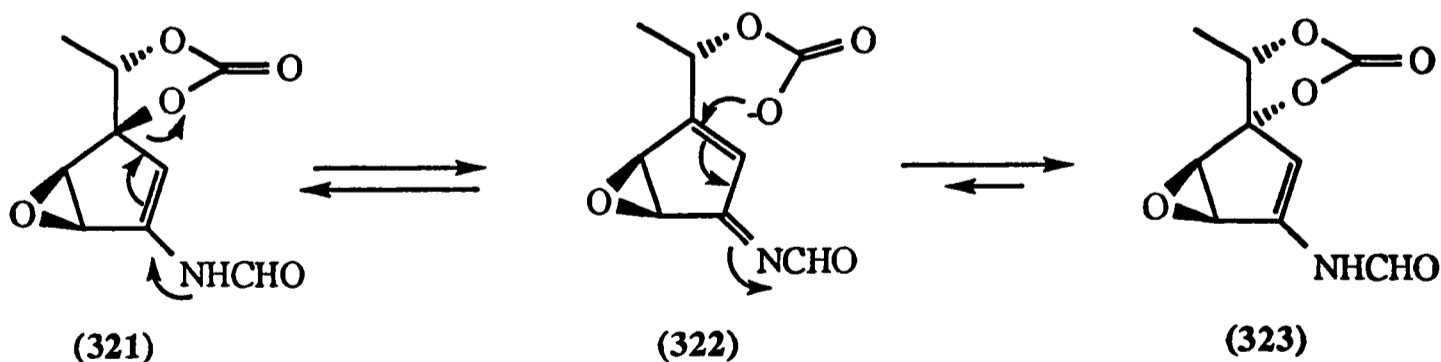

Scheme 71

Dehydration of impure (319) generated isonitrile (325) which was deprotected with TBAF to afford isonitrin B (15), Scheme 72.¹³¹

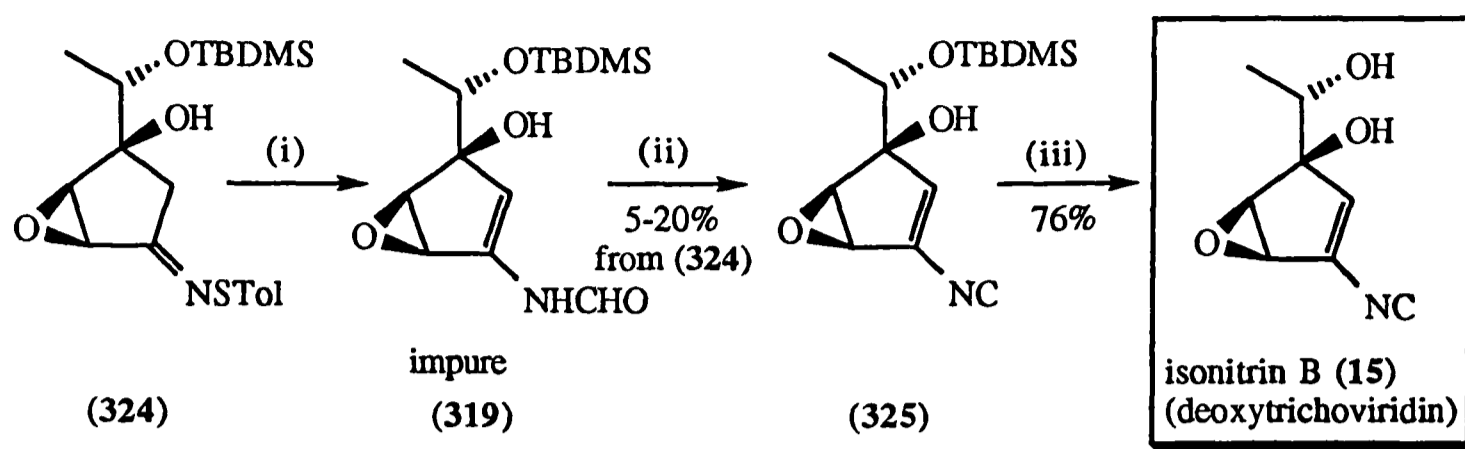

(i) PPh₃ (3 eq.), AcOCHO (3 eq.), propylene oxide, DCM;
(ii) Tf₂O (1.5 eq.), ⁱPr₂EtN (5 eq.), -78°C, 20min.;
(iii) TBAF (1.05eq.), THF, RT, 20min.

Scheme 72

4.4 Previous Synthesis of (±)-Isonitrin A

Isonitrin A (14) was finally synthesised by O'Neil and Russell from isonitrin B using triflic anhydride at low temperature to bring about closure of the exocyclic epoxide in a 34% yield, Scheme 73,²³⁸ after failing to effect the thiooxime to vinyl formamide rearrangement with the exocyclic epoxide already in place (decomposition presumably occurred *via* an analogous pathway to the cyclic carbonate (321), Scheme 71).

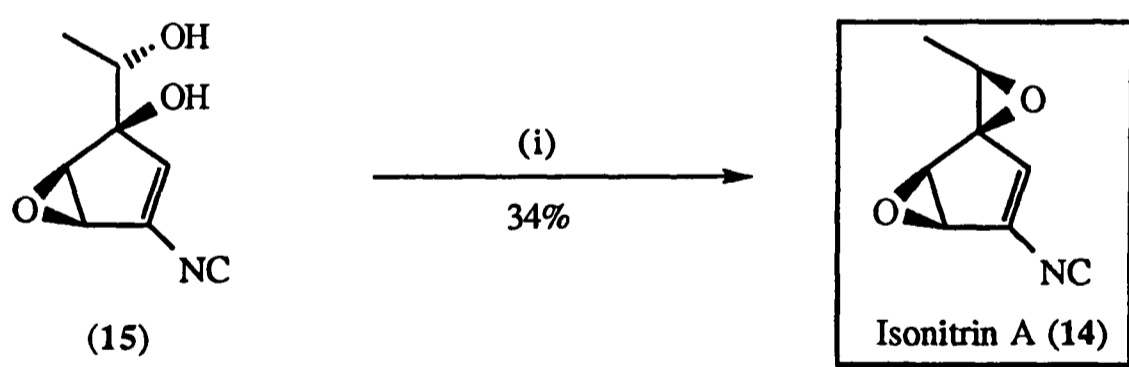

(i) Tf₂O (1.1 eq.), ⁱPr₂EtN (6 eq.), DCM, -78°C.

Scheme 73

4.5 Completion of the Synthesis of (±)-Isonitrin C (Trichoviridin)

4.5.1 Improved Synthesis of the Key Amine Intermediate

At this point the challenge remained to apply the methodology developed by Baldwin and O'Neil, for the preparation of epoxy isonitriles,¹⁷¹ to complete the synthesis of the most

complex member of this family, trichoviridin (16), see Section 2.2.3. Thus vinyl formamide (319) would need to be efficiently prepared and obtained in a pure state. In addition, a number of steps in the current route to (319) would require optimisation and refinement if reasonable quantities of advanced material were to be available to conduct forefront chemistry. Most critically, the epoxy isonitrile functionality needed to be constructed.

Fulvene (327)^{239,240} had been chosen as the precursor of 1-acetylcyclopentadiene (318)^{241,242} and had been prepared in 74% yield from cyclopentadiene in a one synthetic operation which could conveniently be carried out on a one mole scale. As large quantities of this intermediate were available, (327) was used as a starting material by the author.

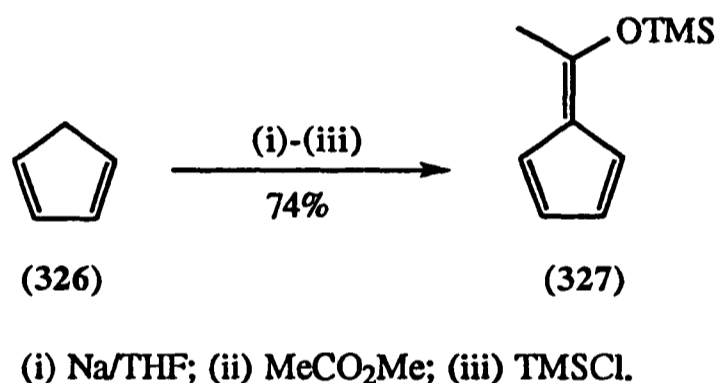

Scheme 74

The bright yellow fulvene (327) was treated with one equivalent of *p*-toluenesulfonic acid monohydrate at -40°C in dichloromethane to generate the deep red colour of 1-acetylcyclopentadiene (318).^{241,242} To the solution of 1-acetylcyclopentadiene (318) was added a solution of benzyl *N*-hydroxycarbamate (329)²⁴³ (prepared from PhCH₂OCOCl (328)) in dichloromethane followed by the addition of tetraethylammonium periodate²⁴⁴ in dichloromethane to effect an *in situ* oxidation of the hydroxamic acid to the acylnitrosodienophile (330). A [4+2] cycloaddition of the acetylcyclopentadiene with the nitroso dienophile then ensued to generate, after work-up, the bicyclic adduct (331) in 98% yield and with a regioselectivity of >20:1, as judged by ¹H n.m.r.²⁴⁵⁻²⁴⁸ The ketone (331) was unstable at room temperature and therefore used directly in the next reaction.

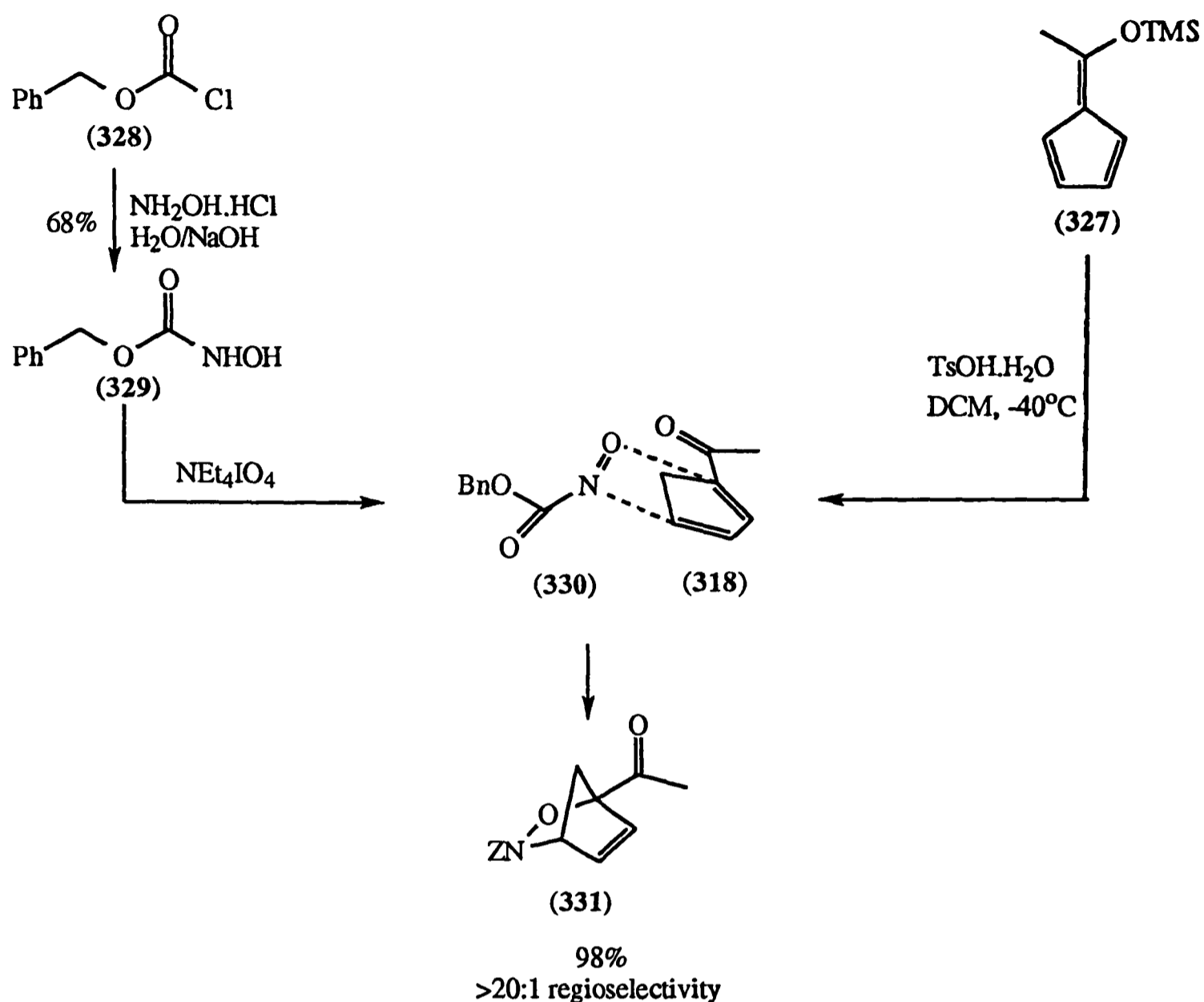

Scheme 75

A number of reagents had been investigated in the attempted diastereoselective reduction of ketone (331). K-Selectride[®]²⁴⁹⁻²⁵¹ at low temperature was found to give a good degree of selectivity (6:1) with the major diastereoisomer being of the correct stereochemistry for the isonitrins.²¹⁴ Unfortunately, the reaction with K-Selectride[®] was low yielding (*ca.* 30-45%) and optimisation of this step was therefore essential. T.l.c. analysis of the reaction mixture indicated that whilst (331) was converted cleanly to (332) at -100°C , decomposition to multiple products resulted on work-up with saturated ammonium chloride solution and subsequent warming of the mixture to ambient temperature. Other proton sources (*e.g.* dilute HCl, acetic acid) were investigated but gave similar results as did attempted oxidative work-up with 30% H_2O_2 in the presence of NaOH.²²⁸ It was finally discovered that rapid quenching of the reaction, by pouring the cold mixture onto silica gel, resulted in significantly reduced decomposition. Concentration of the mixture to dryness was

followed by the application of the silica gel to a flash column. Purification was then effected to give a good yield (79%) of (332), Scheme 76.

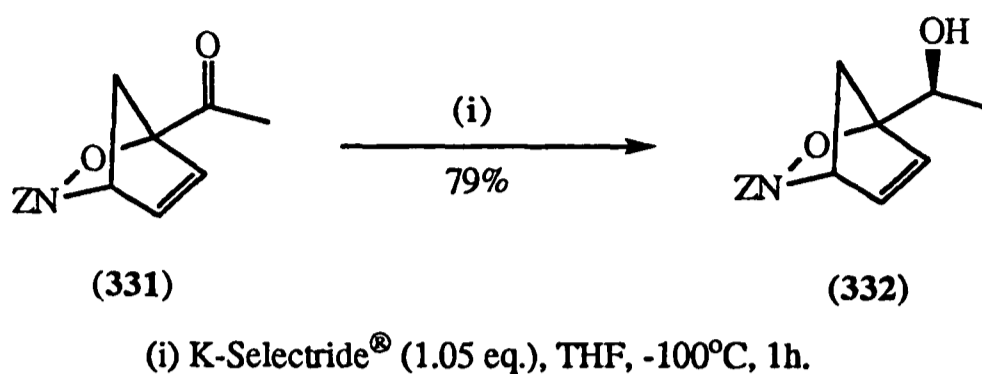

Scheme 76

Protection of the hindered secondary alcohol of (332) as its *t*-butyldimethylsilylether was accomplished using the Corey and Venkateswarlu protocol,²¹⁷ Scheme 77, which offered improved yields over the previously reported method involving TBDMSCl and DBU in dichloromethane.²¹⁵ Treatment of (333) with 6% sodium amalgam in buffered methanol²⁵² gave the tertiary alcohol (334) in 80% yield. Directed epoxidation of (334) with *m*-CPBA^{253,254} generated the key intermediate (335). The selectivity was found to be 10:1 in favour of the required epoxide, Scheme 77, the isomers being separable by flash chromatography.

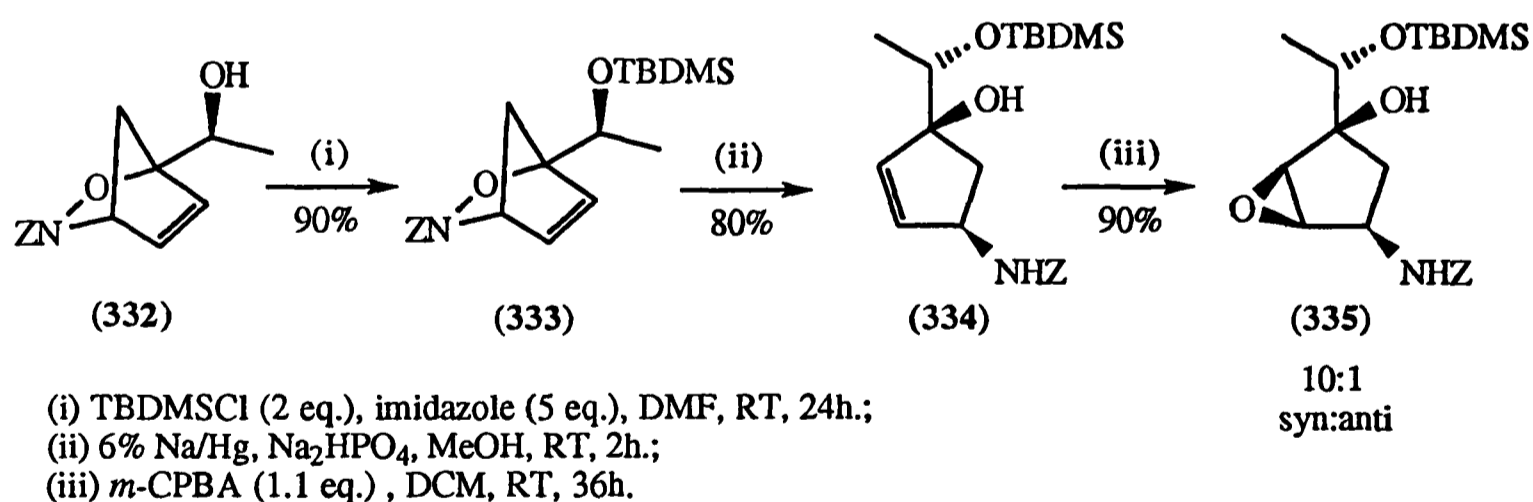

Scheme 77

4.5.2 Improved Synthesis of the Vinyl Formamide

With (335) in hand, the task of preparing vinyl formamide (319) was undertaken. Thus, (335) was subjected to hydrogenolysis to afford the amine (336) which was converted, using Gordons procedure,¹⁵⁴ to thiooxime (324) as a single geometric isomer,

Scheme 78. At this stage it is possible to remove the minor isomer at the secondary alcohol centre by repeated recrystallisation. In order to preserve material the following studies were, however, carried out on the 6:1 epimeric mixture.

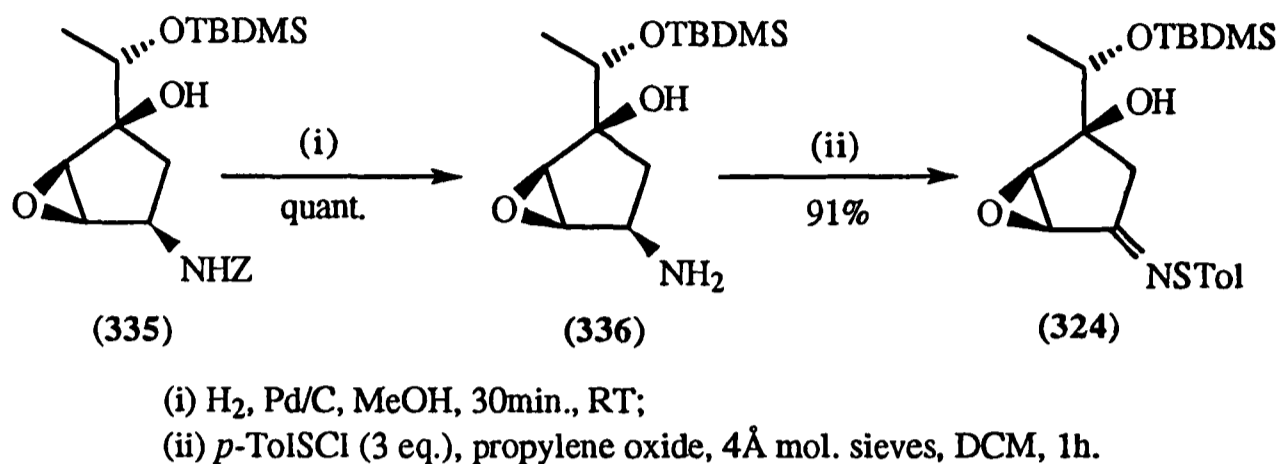

Scheme 78

Previous research by O'Neil had shown that treatment of thiooxime (324) under the previously described conditions of triphenylphosphine, acetic formic anhydride with precautionary use of propylene oxide as an acid scavenger had generated the desired vinyl formamide (319) as detected by ¹H n.m.r. and I.R. spectroscopy. As anticipated the vinyl formamide was unstable to acid but partial purification could be achieved by reverse phase flash chromatography, the major contaminants being triphenylphosphine oxide and an unidentified tolyl containing by-product. Vinyl formamide (319) was successfully dehydrated to afford vinyl isonitrile (325), Scheme 72.¹³⁰ The overall yield of (319) from (324) was, however, low and variable (5-20%).

On one occasion the α -thioformamide (337) had been obtained from the rearrangement reaction. The ¹H n.m.r. was quite complex due to hindered rotation of the formamide but dehydration generated α -thioisonitrile (338) as a crystalline solid which gave satisfactory microanalysis and spectral data. Of interest was the fact that (338) appeared to be a single diastereomer suggesting that the rearrangement had occurred in a stereospecific manner. α -Thioformamide (339) had also been obtained by rearrangement of its corresponding thiooxime and was subjected to X-ray analysis.¹³¹ The tolylthio group was

shown to be on the α -face, Figure 17 and thus it is most likely that (337) and (338) have the structures shown, Scheme 79.

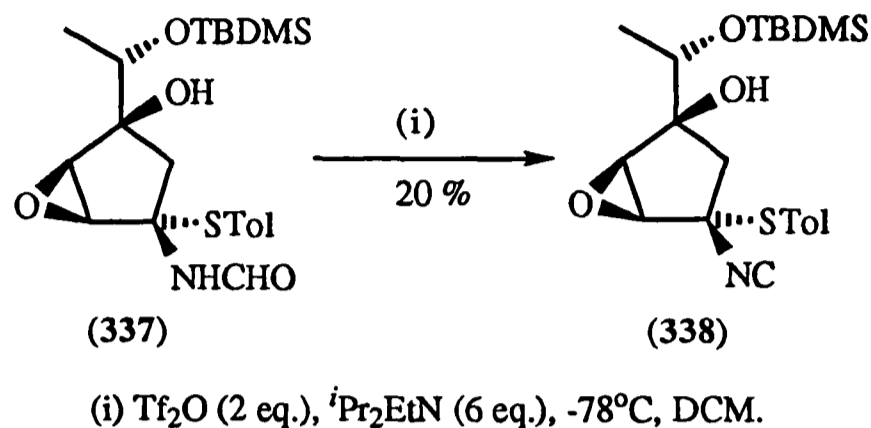

Scheme 79

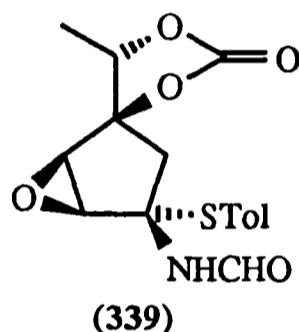
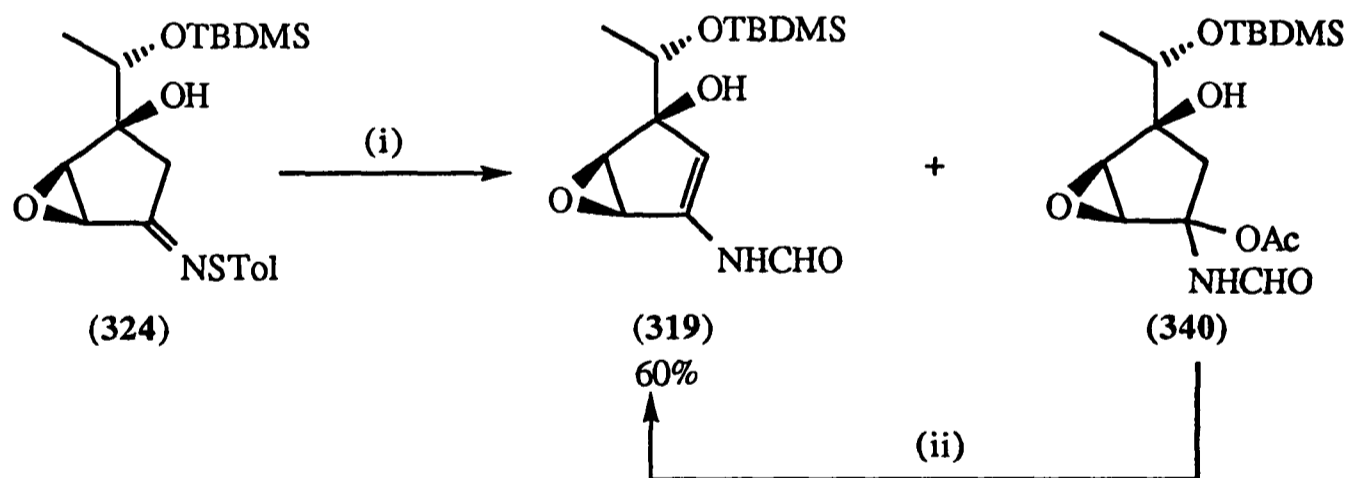

Figure 17

Based on the previously described methodology developed by the author for the synthesis of an analogue of antibiotic A-32390A it was decided that polymer supported triphenylphosphine²²⁴ be used in place of triphenylphosphine in the rearrangement reaction, Section 3.4. It was proposed that this modification would facilitate the preparation of pure vinyl formamide (319). Following filtration of the polymer and work-up the ^1H n.m.r. of the crude reaction mixture indicated that two formamide products had been obtained, the desired vinyl formamide (319) and a compound whose ^1H n.m.r. did not appear to be in agreement with that reported for the α -thioformamide (337).²¹⁵ Again, based on previous work by this author toward the synthesis of an antibiotic A-32390A analogue it was now apparent that α -acetoxy formamides were potential products of this reaction, Chapter 3, and thus it was proposed that (340) is the additional compound generated. It proved impossible to separate (319), (340) and the tolyl containing by-product by reverse phase h.p.l.c. The

ratio of (319) and (340) was found to change considerably from reaction to reaction which may account for the varying yields previously obtained for (325) after dehydration. On one occasion (340) was obtained as the sole formamide containing product. The ^1H n.m.r. was again complex due to hindered rotation of the formamide but (340) appeared to be present as a single diastereoisomer at the new chiral centre.[†] Mass spectroscopy of the mixture of (340) and the tolyl containing by-product (subsequently identified as *p*-tolylthioformate) gave mass ions consistent with the corresponding imine. This is proposed to result from elimination of acetate and is therefore consistent with the proposed structure. The next step was to determine whether α -acetoxyformamide (340) could be converted to vinyl formamide (319) as had been possible with the α -carboxy systems discussed in Chapter 3. Treatment of the crude reaction mixture with the DBU was found to bring about elimination of acetate from (340) and its conversion to (319). Fortunately the *p*-tolylthioformate also reacted with DBU which enabled (319) to be obtained cleanly by reverse phase h.p.l.c. in a yield of 60% from (324), Scheme 80.



(i) polymer supported PPh_3 (3 eq.), AcOCHO (3 eq.), propylene oxide, DCM, RT, 24h.;
 (ii) DBU (5 eq.), DCM, RT, 2h.

Scheme 80

[†] ^1H (200MHz) 0.10 and 0.11 (6H, 2 x s, SiCH_3), 0.91 (9H, s, $\text{SiC}(\text{CH}_3)_3$, minor rotamer), 0.92 (9H, s, $\text{SiC}(\text{CH}_3)_3$, major rotamer), 1.22 (3H, d, J 6.5Hz, CHCH_3 , major rotamer), 1.24 (3H, d, J 6.5Hz, CHCH_3 , minor rotamer), 1.90-2.10 and 2.62-2.79 (2H, 2 x m, $\text{CH}_2\text{C}(\text{OH})$), 3.59-4.11 (2H, m, CHCH), 4.32-4.38 (1H, m, $\text{CH}(\text{OH})$), 6.82 (1H, br s, NHCHO , major rotamer), 6.95 (1H, d, J 11Hz, NHCHO , minor rotamer), 8.15 (1H, s, NHCHO , major rotamer) and 8.52 (1H, d, J 11Hz, NHCHO , minor rotamer); m/z (chemical ionisation) 318[(M-AcOH+ NH_4)⁺, 19%], 301[(M-AcOH+H)⁺, 20], 290[100], 273[45], 159[52], 143[44], 132[48], 124[40], 91[72] and 74[42].

4.5.3 Improved Synthesis of the Vinyl Isonitrile

In an attempt to improve the overall yield of isonitrin B (15), dehydration of pure (319) was carried out. This resulted in a 72% yield of (325) and hence an overall yield of 43% from thiooxime (324), Scheme 81.

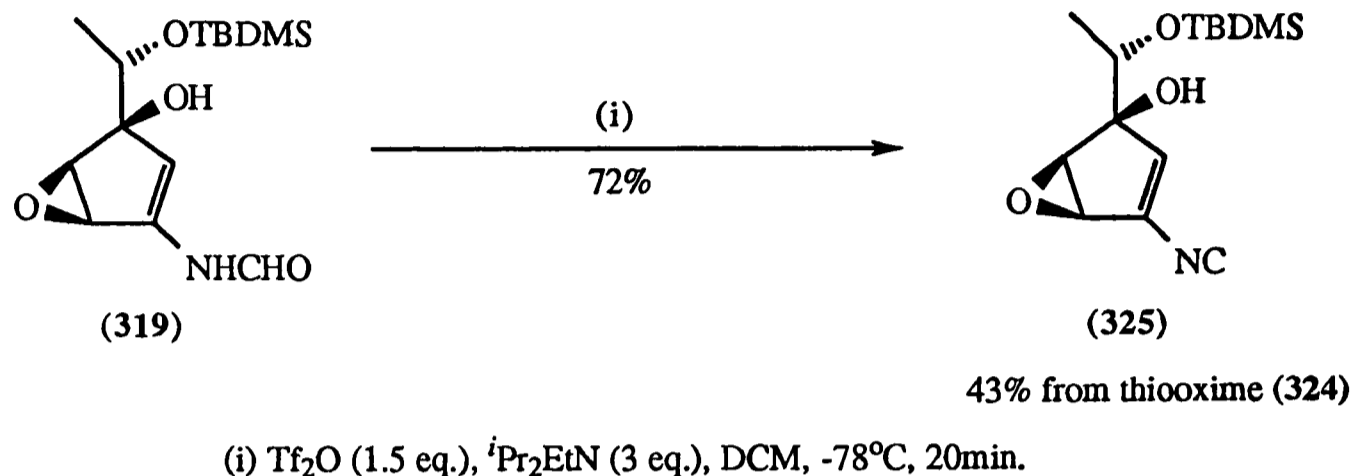

Scheme 81

Even higher yields of (325) from (324) could, however, be obtained by direct dehydration of crude vinyl formamide (319) without recourse to h.p.l.c., Scheme 82. In addition, it was found possible to separate the minor epimer at the secondary alcohol centre at this stage by flash chromatography. This offered a practically more attractive alternative to the repeated recrystallisation of thiooxime (324) at low temperature. Following these studies an overall yield of 19%, in nine steps from fulvene (327), has been achieved for the synthesis of isonitrin B. Thus the initial goal of applying the lessons learnt from the synthesis of the antibiotic A-32390A analogue had led to the successful optimisation of this sequence. It now remained to integrate these results and a successful epoxidation of the C4-C5 double bond to complete the synthesis of trichoviridin.

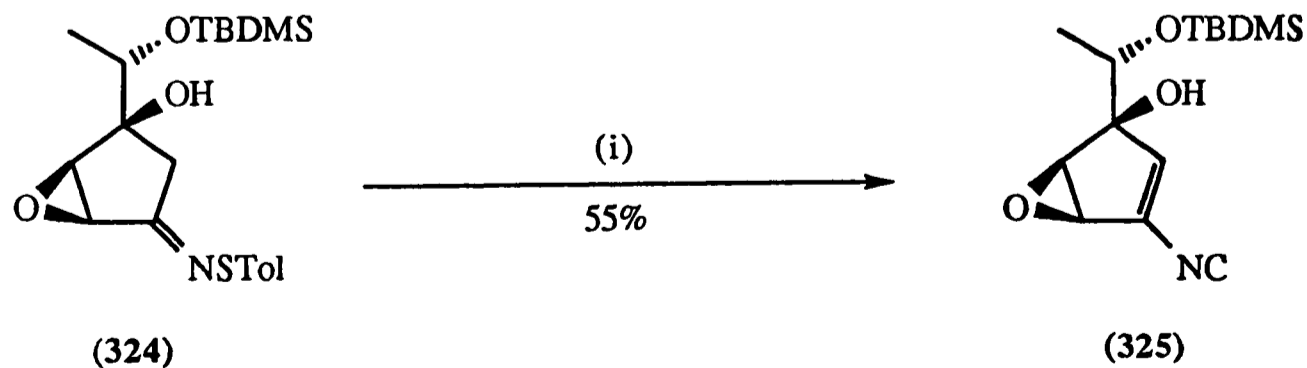

(i) polymer supported PPh_3 (3 eq.), AcOCHO (3 eq.), propylene oxide, DCM, RT, 12h. then DBU (3 eq.), DCM, RT, 2h. then Tf_2O (2 eq.), $i\text{Pr}_2\text{EtN}$ (3 eq.), DCM, -78°C , 30min.

Scheme 82

4.5.4 Attempted Epoxidation/Dehydration of the Vinyl Formamide

Thus far, the Baldwin group has developed two synthetic strategies for the assembly of epoxy isonitriles *e.g.* (342), Scheme 83. Strategy A involves the direct epoxidation of vinyl isonitriles and Strategy B the epoxidation of a vinyl formamide to give an epoxy formamide (343) which could be dehydrated to the epoxy isonitrile.

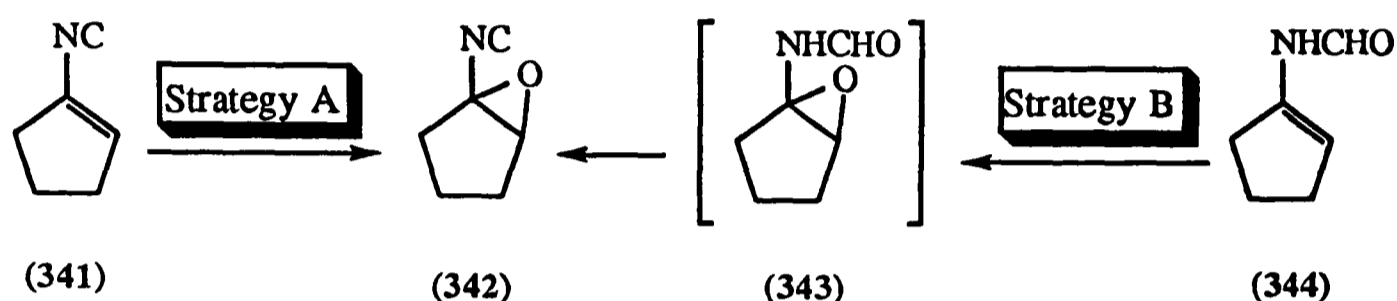

Scheme 83

Early work toward the synthesis of epoxy isonitriles, by Dr. A.E. Derome,²³⁷ had indicated that Strategy A leads to the formation of epoxy isocyanates in solution and polymeric material on attempted isolation. For this reason recent attention has focused on Strategy B. One problem with this approach is the extreme acid sensitivity of epoxyformamide (343), Scheme 83, which precludes the use of epoxidising agents such as *m*-CPBA which are either acidic or have acidic by-products. Previous results have demonstrated that the neutral, electrophilic epoxidising agent, dimethyldioxirane,²⁵⁵ was found to be successful in the formation of epoxy isonitriles. Such a strategy demanded that the intermediate epoxy formamide was dehydrated *in situ* with triflic anhydride, Section 2.2.3.¹⁷¹ The yields of the epoxy isonitriles obtained were modest and optimisation was therefore essential before the methodology was applied to the synthesis of trichoviridin (16).

Model studies were carried out with vinyl formamide (347) prepared from ketone (345) in two steps, Scheme 84.^{152,153}

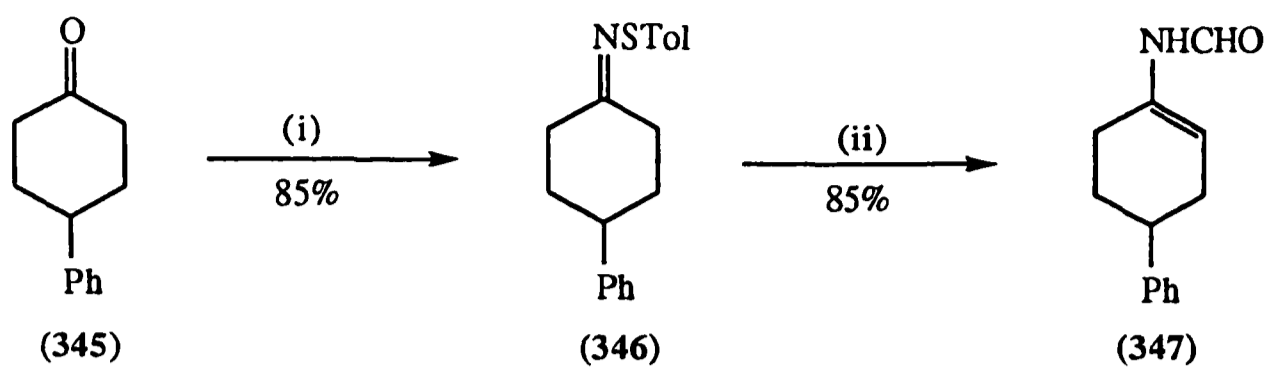

(i) TolSN(TMS)₂ (1.1 eq.), TBAF (cat.), THF, RT, 24h.;
 (ii) PPh₃ (3 eq.), AcOCHO (3 eq.), propylene oxide, DCM, RT, 24h.

Scheme 84

Dimethyldioxirane was prepared as a solution in acetone by the oxidation of acetone with potassium monoperoxysulfate (available commercially as a triple salt known as Oxone[®]) followed by low temperature distillation.^{256,257} The solution was thoroughly dried with 4Å molecular sieves and the concentration determined by titration with thioanisole using ¹H n.m.r spectroscopy. The concentration was typically of the order of 0.1M. Treatment of (347) with one equivalent of dimethyldioxirane at -40°C for ten minutes followed by dehydration at -78°C afforded a modest, 40%, yield of the epoxy isonitrile (348) comparable to that obtained by O'Neil. In addition, the corresponding vinyl isonitrile (349) was isolated as a result of incomplete epoxidation. It had previously been shown that the use of excess dioxirane resulted in the destruction of the product epoxy isonitrile, presumably by oxidation of the isonitrile to the isocyanate followed by polymerisation of the epoxy isocyanate.²¹⁵ However, it was found that a much improved yield of (348) could be obtained using three equivalents of dimethyldioxirane provided that following epoxidation, an excess (ten equivalents) of the base *N,N*-diisopropylethylamine was added to consume the remaining dioxirane by formation of its *N*-oxide. This mixture was allowed to stir for one minute before dehydration was effected with triflic anhydride, Scheme 85. Only 1.5 equivalents of triflic anhydride were required so it may be concluded that the dehydration proceeds more rapidly than any potential Polonovski reaction of the *N*-oxide.²⁵⁸

In an attempt to further improve the yield of (348) a number of different bases were examined in place of *N,N*-diisopropylethylamine. The use of stronger or weaker bases, however, resulted in reduced yields, Scheme 85.

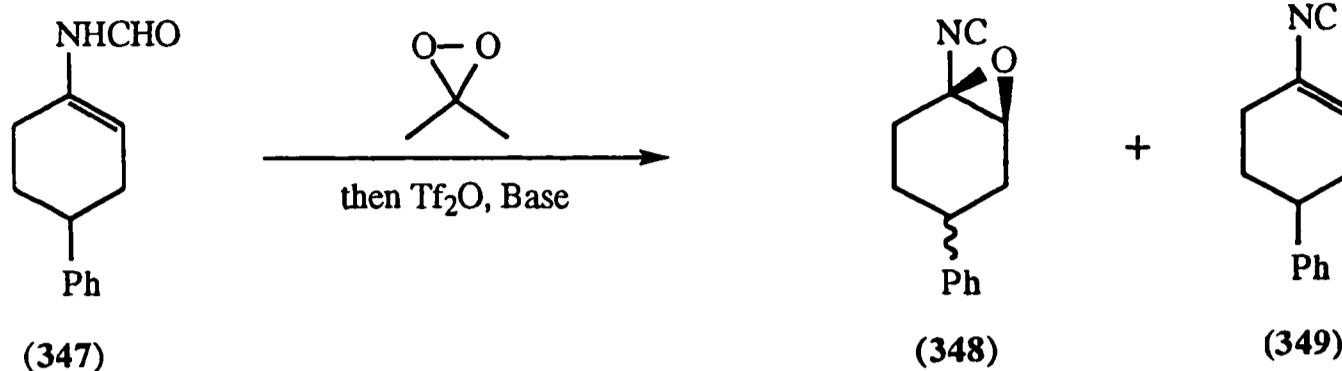

dimethyldioxirane (1 eq.), -40°C, DCM, 10min.
then Tf₂O (1.5 eq.), ⁱPr₂EtN (3 eq.), -78°C, 20min.

47%

10%

dimethyldioxirane (3 eq.), -40°C, DCM, 10min.
then Tf₂O (1.5 eq.), ⁱPr₂EtN (10 eq.), -78°C, 20min.

74%

0%

dimethyldioxirane (3 eq.), -40°C, DCM, 10min. then
Tf₂O (1.5 eq.), Proton sponge (10 eq.), -78°C, 20min.

0%

0%

dimethyldioxirane (3 eq.), -40°C, DCM, 10min. then
Tf₂O (1.5 eq.), *N*-methylmorpholine (10 eq.), -78°C, 20min.

42%

0%

dimethyldioxirane (3 eq.), -40°C, DCM, 10min.
then Tf₂O (1.5 eq.), DBU (10 eq.), -78°C, 20min.

13%

0%

Scheme 85

Attempts were then made to apply the methodology to the synthesis of trichoviridin (16). Baumstark, Kurihara and Curci have shown that dioxiranes preferentially epoxidise *anti* to tertiary allylic hydroxyls, as a result of "H-bonding disrupting or at least slowing attack *syn* to the hydroxy function."²⁵⁹⁻²⁶¹ In addition, work on the rearrangement reaction, *vide supra*, has indicated that the α face is also the sterically more accessible thus it was hoped that epoxidation would occur primarily on this face. Unfortunately attempted epoxidation using the conditions developed for the model system led only to the formation of vinyl isonitrile (325) as a result of the direct dehydration of (319). No epoxidation was observed, presumably as a result of the reduced electron density of the double bond in (319) compared to the model system (347). This was attributed to the number of electron withdrawing groups around the cyclopentane ring and increased steric hindrance.

Epoxidation was also attempted at -20°C , 0°C , and ambient temperature with similar results, Scheme 86.

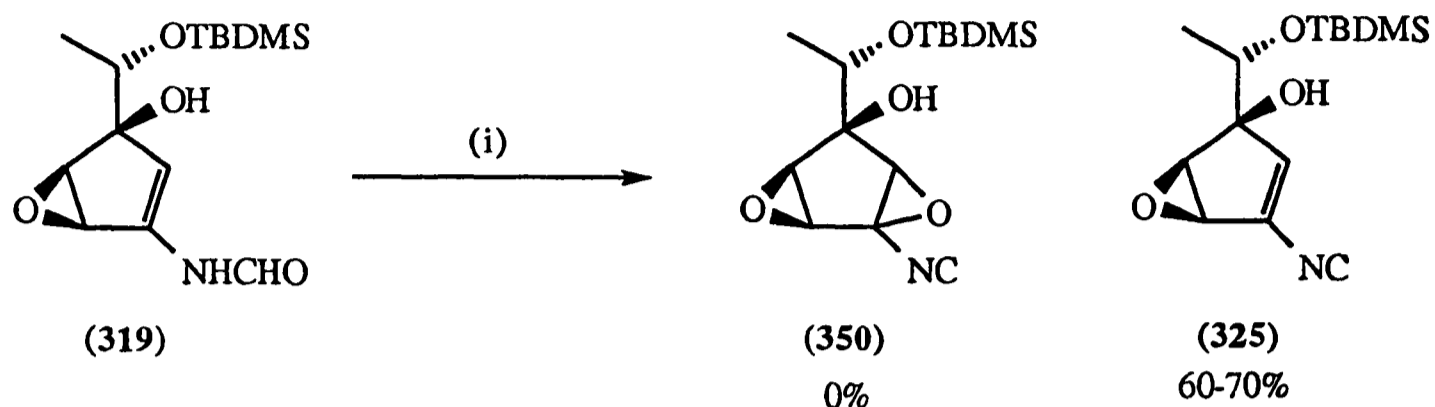

(i) dimethyldioxirane (3 eq.), -40°C , DCM, 10 min. then TiF_2O (1.5 eq.), $i\text{Pr}_2\text{EtN}$ (3 eq.), -78°C , 20min.
Epoxidation also attempted at -20°C , 0°C and RT for 10 min.

Scheme 86

Despite its electrophilic nature, dimethyldioxirane has been used to epoxidise electron deficient double bonds such as those in α,β -unsaturated carbonyl compounds.^{262,263} An excess of the reagent, longer reaction times and elevated temperatures are, however, required. Thus, a number of experiments were conducted with the model system (347) in order to determine the stability of the intermediate epoxy formamides and hence the length of time the epoxidation of (319) may be left before dehydration. Reduced yields of 50% and 40% were obtained on leaving the epoxidation stage for two hours at -40°C and 0°C respectively and complete decomposition resulted on leaving the epoxidation for twelve hours at -40°C or two hours at ambient temperature, Scheme 87. It therefore seemed unlikely that the reaction with vinyl formamide (319) could be left for extended periods in order to effect epoxidation.

Methyl(trifluoromethyl)dioxirane was first obtained in 1988 by Curci and found to exhibit a reactivity far exceeding that of dimethyldioxirane.²⁶⁴ For example, the oxidation of phenanthrene (351) to its 9,10 epoxide (352) takes place with greater than 80% conversion in five minutes at -20°C whereas only 50% conversion is obtained with dimethyldioxirane in twenty hours at 22°C . The rapid oxidation of even weakly activated C-H bonds is also possible with this reagent,²⁶⁵ Scheme 88.

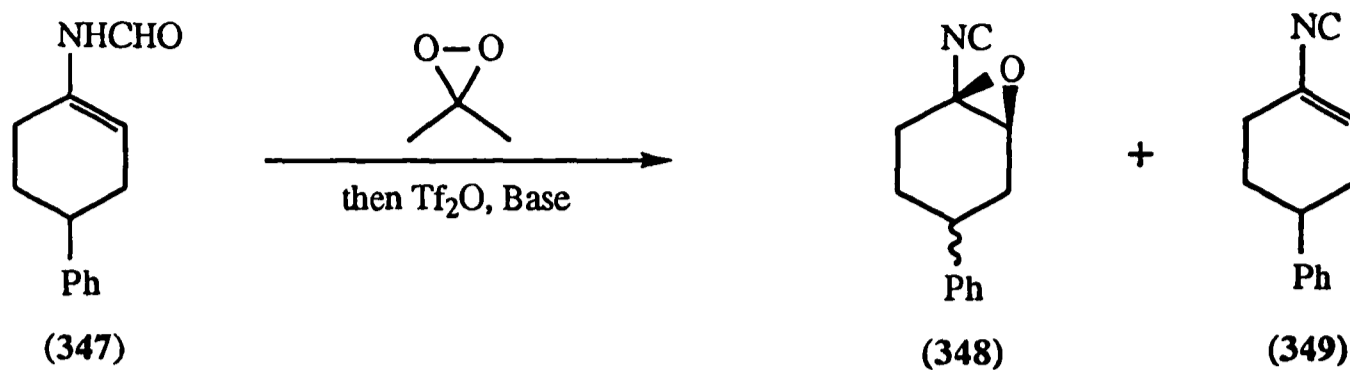

dimethyldioxirane (3 eq.), -40°C, DCM, 2h.
then Tf₂O (1.5 eq.), ⁱPr₂EtN (3 eq.), -78°C, 20min.

50%

0%

dimethyldioxirane (3 eq.), -40°C, DCM, 12h.
then Tf₂O (1.5 eq.), ⁱPr₂EtN (10 eq.), -78°C, 20 min.

0%

0%

dimethyldioxirane (3 eq.), 0°C, DCM, 2h.
then Tf₂O (1.5 eq.), ⁱPr₂EtN (10 eq.), -78°C, 20 min.

40%

0%

dimethyldioxirane (3 eq.), RT, DCM, 2h.
then Tf₂O (1.5 eq.), ⁱPr₂EtN (10 eq.), -78°C, 20min.

0%

0%

Scheme 87

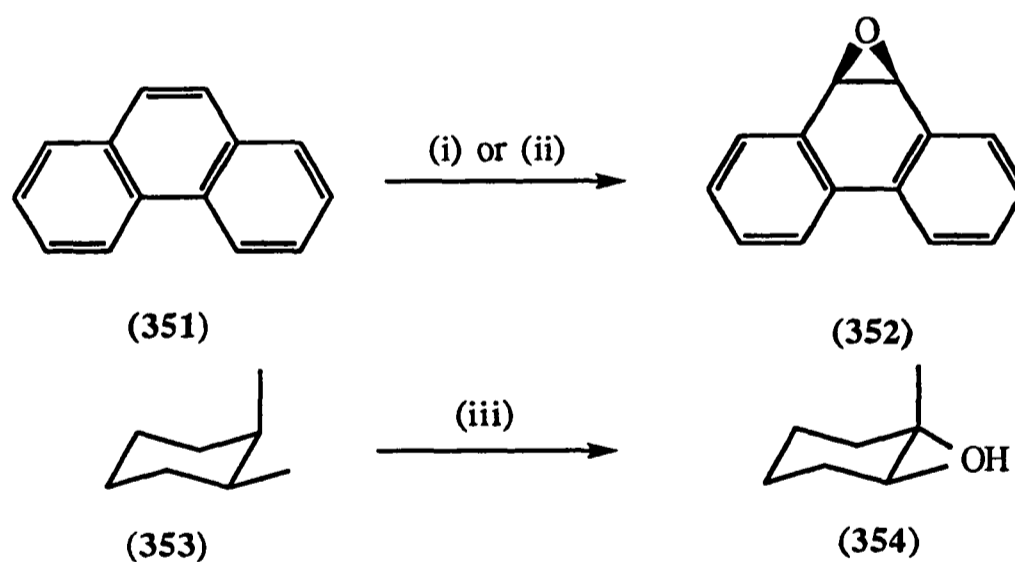

(i) methyl(trifluoromethyl)dioxirane, 5min. -20°C, 80% conversion;

(ii) dimethyldioxirane, 20h. 22°C, 50% conversion;

(iii) methyl(trifluoromethyl)dioxirane, 10min., DCM, 22°C, >80% conversion.

Scheme 88

We were intrigued by a report by Adam *et al.* on the epoxidation of silyl enol ethers, phthalides and enol esters with dimethyldioxirane in which was stated that the "addition of 1,1,1-trifluoroacetone promoted epoxidation under conditions at which dimethyldioxirane

was ineffective."²⁶⁶ This was believed to be a result of oxygen exchange which afforded the more reactive methyl(trifluoromethyl)dioxirane *in situ*. The exact nature of the relevant substrates was not specified and so the validity of this statement was tested with the α,β -unsaturated system (355). Treatment of (355) with 0.8 equivalents of dimethyldioxirane with and without 1,1,1-trifluoroacetone was found to lead to 41% conversion of (355) to the corresponding epoxide (356) in both cases (as judged by ¹H n.m.r), Scheme 89. As no difference in reaction rate was observed some doubt is cast on the suggestion that the more reactive dioxirane is generated *in situ*.

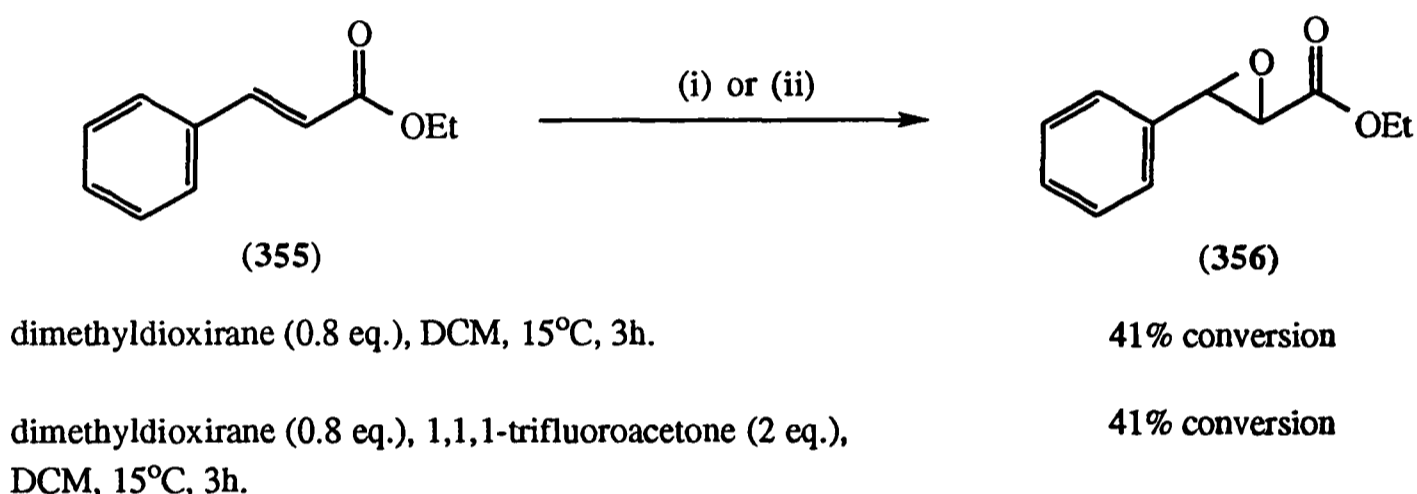

Scheme 89

Methyl(trifluoromethyl)dioxirane was obtained as a solution in 1,1,1-trifluoroacetone by the Oxone[®] oxidation of 1,1,1-trifluoroacetone, using a scaled-down version of Curci's procedure²⁶⁵ and thoroughly dried with 4Å molecular sieves. Due to problems handling the solution, as a result of its volatility, a concentration of 0.5M was generally assumed. This dioxirane was found to be unstable, decomposing rapidly at -20°C despite efforts to avoid contamination with metal ions and to protect the solution from light. In contrast to dimethyldioxirane which decomposes to the 1,2,4,5-tetraoxane (ketone diperoxide) (358),²⁶⁷ the exothermic decomposition of (359) results in the formation of trifluoroacetic acid (361) (TFA) *via* its methyl ester (360), Scheme 90.²⁶⁵

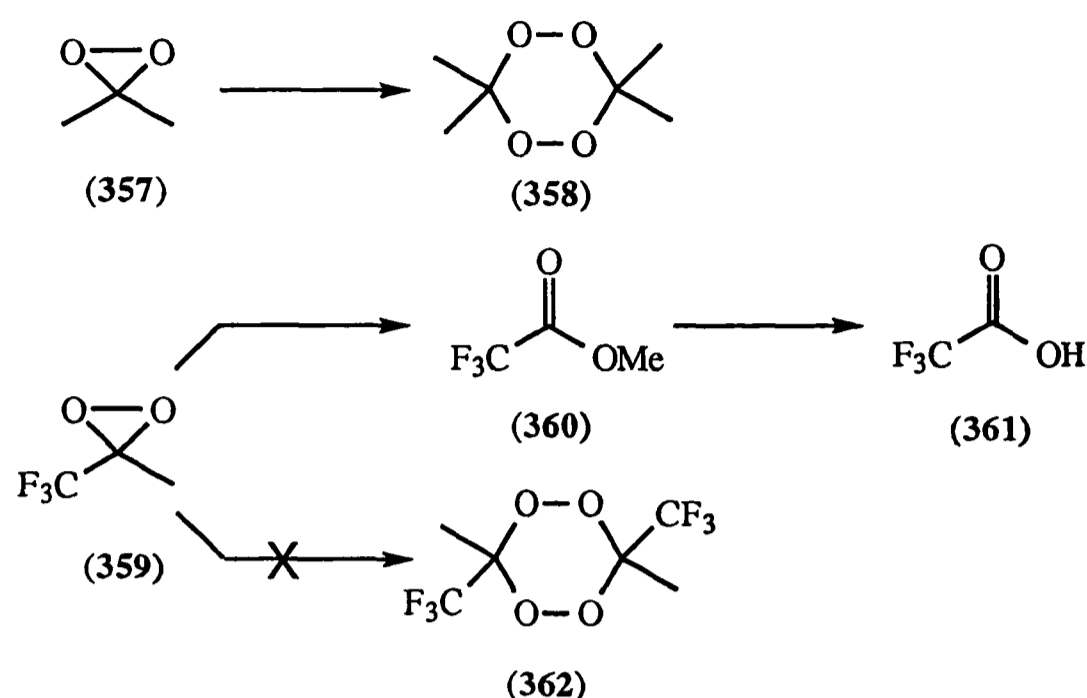

Scheme 90

Its applicability to the synthesis of epoxy isonitriles was first tested on the model system (347). Treatment of (347) with methyl(trifluoromethyl)dioxirane followed by dehydration using the optimal conditions developed for dimethyldioxirane gave a disappointing yield (5%) of epoxy isonitrile (348). An increased yield of 20% was obtained on carrying out both the epoxidation and dehydration at -78°C . Curci has successfully achieved the rapid, low temperature epoxidation of acid sensitive enol ethers with methyl(trifluoromethyl)dioxirane by the addition of the buffer Na_2HPO_4 which presumably acts to scavenge any TFA.²⁶⁸ A much improved, 56% yield was obtained on the addition of this reagent to the epoxidation of (347) but a further increase in yield (to 76%) was achieved by changing the acid scavenger to propylene oxide, Scheme 91.

Finally, attempts were made to epoxidise the C4-C5 bond of vinyl formamide (319) with this more reactive dioxirane. On carrying out the dehydration and epoxidation at -78°C vinyl isonitrile (325) was obtained in 50% yield along with traces of two other isonitrile containing compounds. Increasing the temperature of the epoxidation stage to -40°C resulted in the sole formation of these compounds. Spectroscopic analysis then indicated that neither were the desired epoxy isonitrile (350) but rather a pair of isonitriles of structure (263), Scheme 92. Thus the tertiary alcohol appears to have formed a hemiacetal with 1,1,1-trifluoroacetone present in the solution²⁶⁹ and is presumably stabilised by H-bonding to the

ketone moiety. The ketone may have originated by the direct oxidation of the alkene C-H but more likely is the result of the reaction shown in Scheme 93. Initial epoxidation of (319) to generate epoxy formamide (364) is followed by ring opening to deliver imine (265). Tautomerisation in an Amadori type rearrangement then delivers formamide (267) which is subsequently dehydrated.

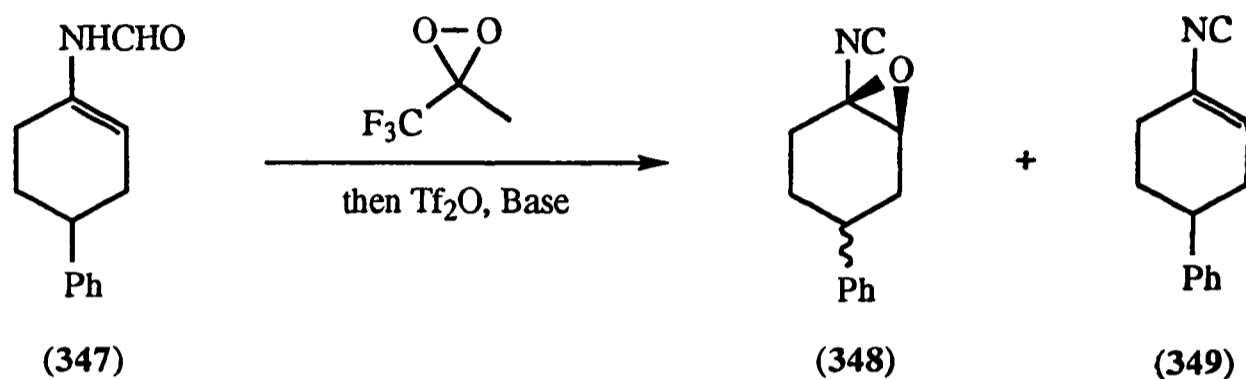

methyl(trifluoromethyl)dioxirane (3 eq.), -40°C, DCM, 10min.
then Tf₂O (1.5 eq.), ⁱPr₂EtN (10 eq.), -78°C, 20min. 5% 0%

methyl(trifluoromethyl)dioxirane (3 eq.), -78°C, DCM, 10min.
then Tf₂O (1.5 eq.), ⁱPr₂EtN (10 eq.), 20min. 20% 0%

methyl(trifluoromethyl)dioxirane (3 eq.), -78°C, DCM, 10min.,
Na₂HPO₄, then Tf₂O (1.5 eq.), ⁱPr₂EtN (10 eq.), 20min. 56% 0%

methyl(trifluoromethyl)dioxirane (3 eq.), -78°C, DCM, 10min.,
propylene oxide, then Tf₂O (1.5 eq.), ⁱPr₂EtN (10 eq.), 20min. 76% 0%

Scheme 91

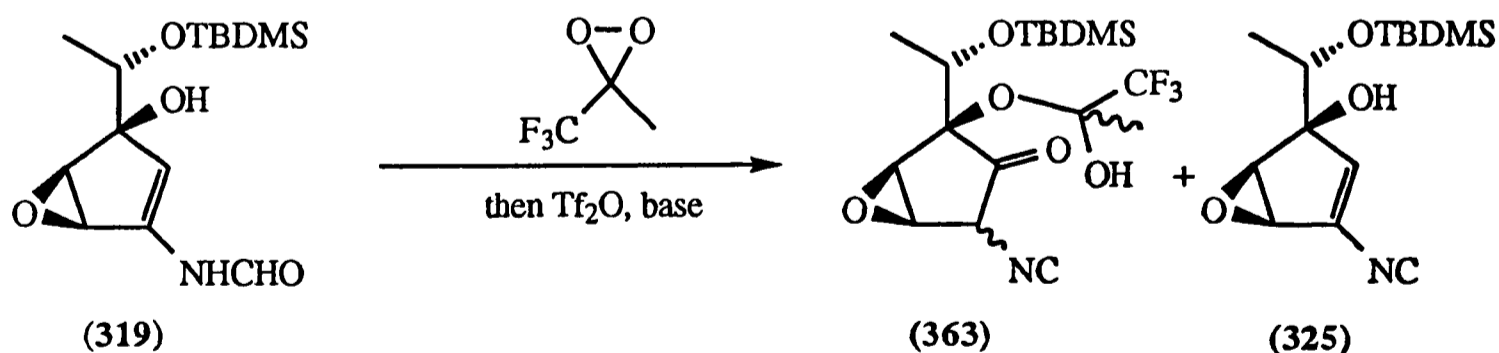

(i) methyl(trifluoromethyl)dioxirane (3 eq.), -78°C, DCM,
propylene oxide, 10min. then Tf₂O (1.5 eq.), ⁱPr₂EtN (10 eq.),
-78°C, 20min. trace 50%

(ii) methyl(trifluoromethyl)dioxirane (3 eq.), -40°C, DCM,
propylene oxide, 10min. then Tf₂O (1.5 eq.), ⁱPr₂EtN (10 eq.),
-78°C, 20min. 60% 0%

Scheme 92

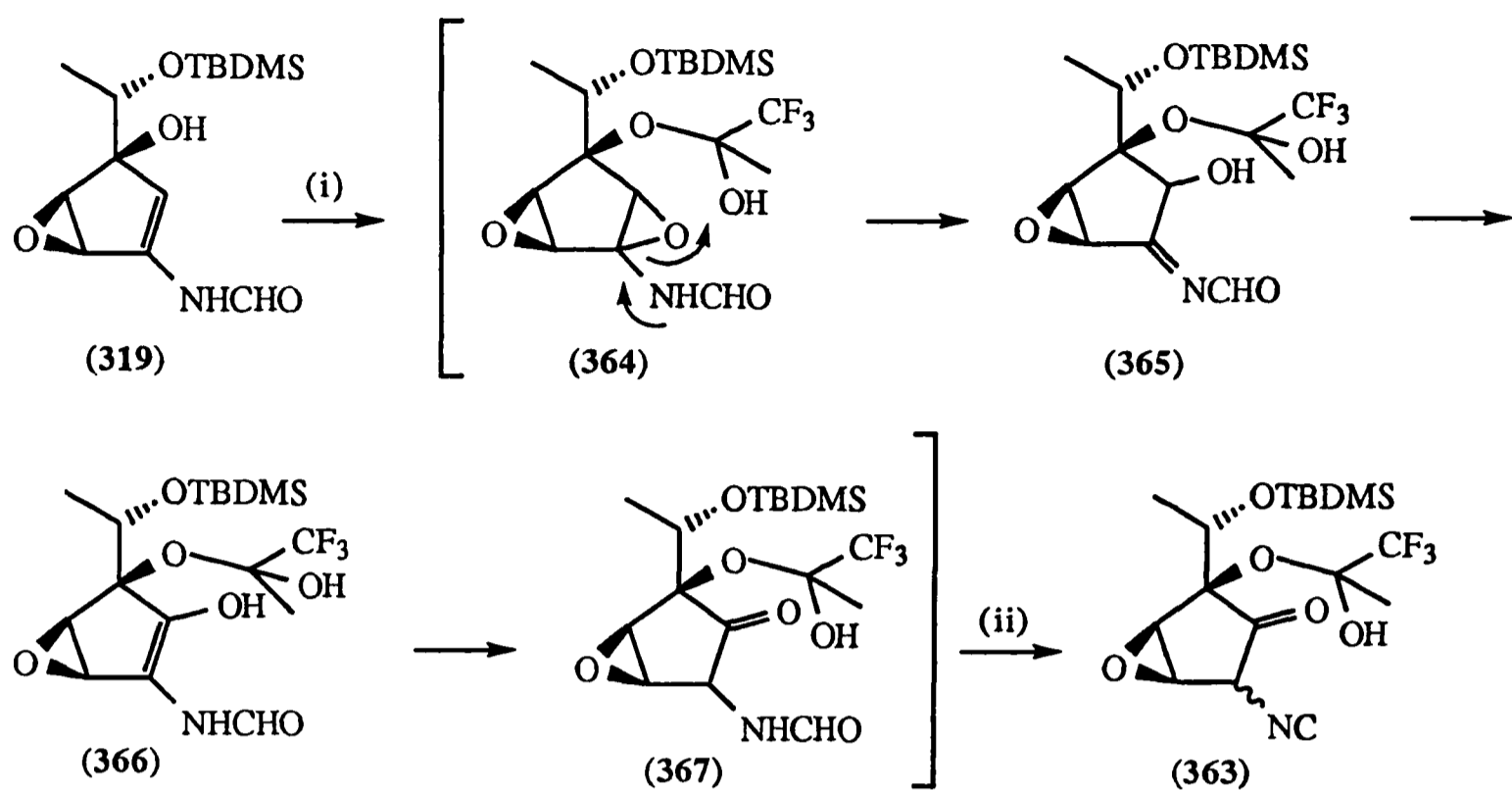

(i) methyl(trifluoromethyl)dioxirane (3 eq.), 1,1,1-trifluoroacetone, -40°C , DCM, propylene oxide, 10min. then (ii) Tf_2O (1.5 eq.), $i\text{Pr}_2\text{EtN}$ (10 eq.), -78°C , 20min.

Scheme 93

In keeping with our observations are the results obtained by Adam for the epoxidation of enamines such as (268).²⁷⁰ Treatment of (268) with dimethyldioxirane at 20°C resulted in the formation of dimer (369) *via* ring opening of the epoxide. Tautomerisation is not possible in this case due to the substitution of the enamine with alkyl groups. The addition of alcohols to the mixture such as methanol leads to the formation of species such as (372). Even at low temperatures no monomeric epoxides were observed due to their extreme lability.

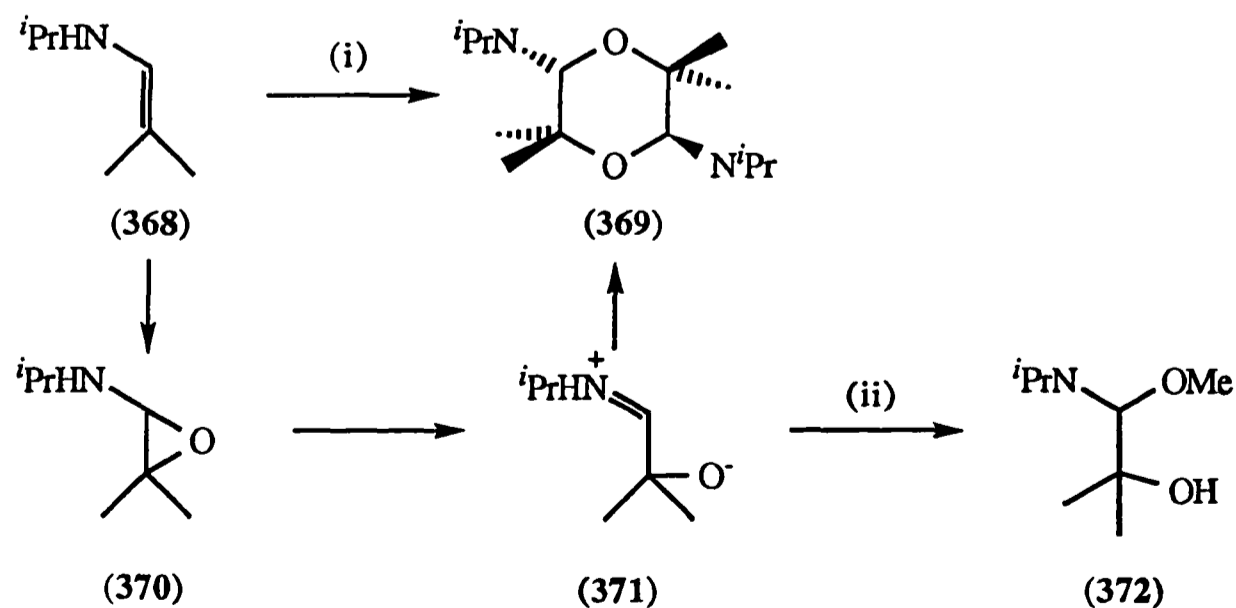

(i) dimethyldioxirane, acetone, 20°C , 30min.; (ii) MeOH, -70°C .

Scheme 94

Depending on the stereochemistry of an epoxide such as (364) it was thought that either the formation of the hemiacetal or the hydroxyl group directly may be leading to the more facile ring opening of the epoxide from (319) by H-bonding to this group. If epoxidation had occurred on the desired α -face then either enhanced ring strain in the tricyclic system may be responsible for the decreased stability. To address the first point the tertiary alcohol was blocked as its TMS ether in quantitative yield with TMSCN.²³² Attempts to form the epoxy isonitrile from (373), were carried out on a small scale but appeared, from ^1H n.m.r. of the crude reaction mixture, to have resulted in the formation of ketone (374) as a mixture of isomers, Scheme 95.

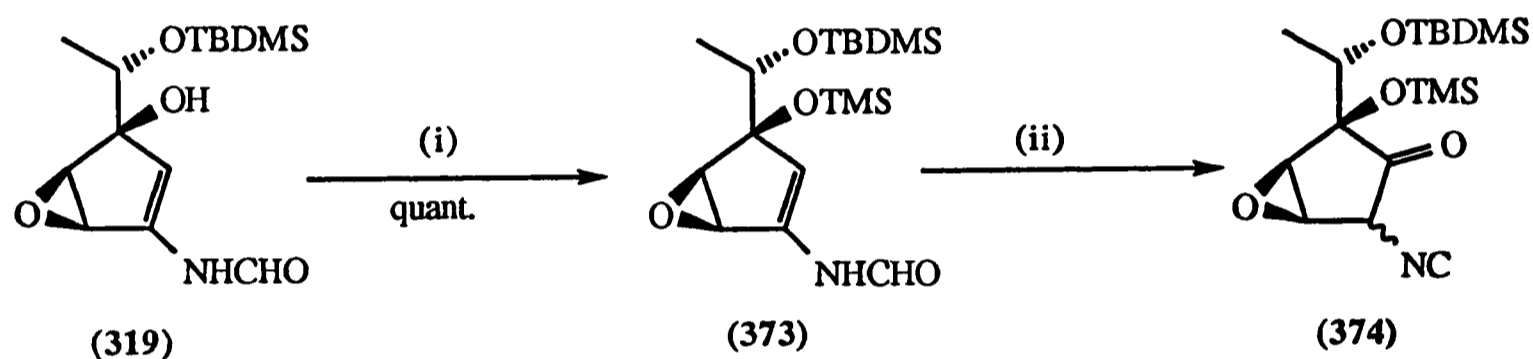

(i) TMSCN, DMF; (ii) methyl(trifluoromethyl)dioxirane (3 eq.), -40°C, DCM, propylene oxide, 10min then Tf₂O (1.5 eq.), ⁱPr₂EtN (10 eq.), -78°C, 20min.

Scheme 95

4.5.5 Epoxidation of an Isonitrile Derivative

An alternative strategy was clearly required for the preparation of the epoxy-isonitrile moiety of trichoviridin. Thus, it was decided to reinvestigate Strategy A, Scheme 83, but with the added introduction of a masking group for the isonitrile function that would 'tie-up' the carbon lone pair and prevent the oxidation of this moiety during epoxidation of the C4-C5 double bond. Taylor, for instance, has recently discussed the use of rhodium and palladium complexes in a protection rôle to assist in the isolation and structure determination of some unstable isonitriles such as isonitrile 270 (10), Section 1.2.1.^{38,39}

More pertinent to the present case, Professor A.G.M. Barrett (Imperial College) disclosed to a member of our group, in a verbal personal communication, that he was examining the following strategy for the preparation of epoxy-isonitriles. Masking of the

isonitrile functionality of (375) was effected by conversion to its corresponding dichloroimine (376) and was then followed by epoxidation. Removal of the chlorine atoms was carried out by treatment with tri-*n*-butyltinhydride with AIBN as initiator to generate the desired epoxy-isonitrile (378).²⁷¹

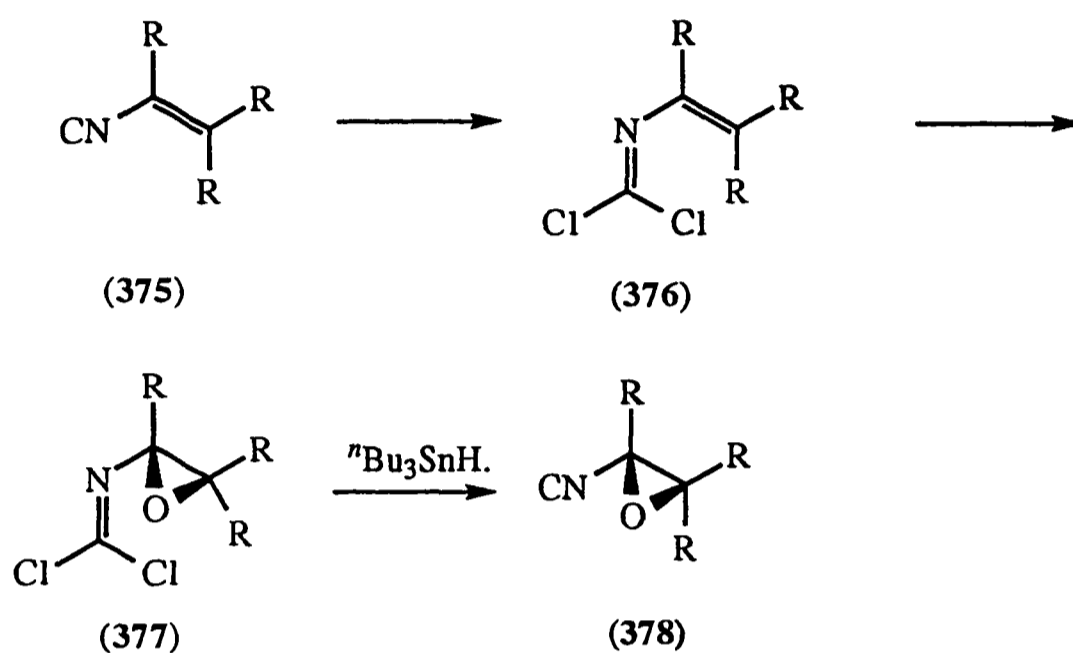

Scheme 96

4.5.5.1 The Dichloroimine as an Isonitrile "Protecting Group"

The dichloroimine moiety was first examined in the "protecting group" rôle for the synthesis of trichoviridin for a number of reasons. Firstly, a number of methods are available for the removal of the chlorine atoms to regenerate the isonitrile group, see Section 2.4. Secondly, dichloroimines may be prepared simply from isonitriles by the α -addition of chlorine,¹⁸⁶ and thirdly, as isonitrile (325) was available no significant change to the overall strategy for the synthesis of trichoviridin would be required. While considering this approach it is interesting to recall Faulkners suggestion that the dichloroimine acts as a biological protecting group for the isonitrile function in a number of sponge metabolites, Section 1.2.2.⁷⁵⁻⁷⁷

Unfortunately, the chlorination of isonitriles is not a generally applicable process. Whereas aromatic and short chain aliphatic isonitriles undergo chlorination to the corresponding dichloroimine, with dodecyl isocyanide and its higher homologues dichloroimines do not result, as the principal reaction in these cases is side chain

chlorination.¹⁸⁶ Thus, studies were first carried out on simple but relevant model systems. Initial attempts at chlorination of vinyl isonitrile (**349**), prepared by dehydration of (**347**)¹⁵² with a 0.8M solution of chlorine in carbon tetrachloride resulted in the formation of a number of unidentifiable products.

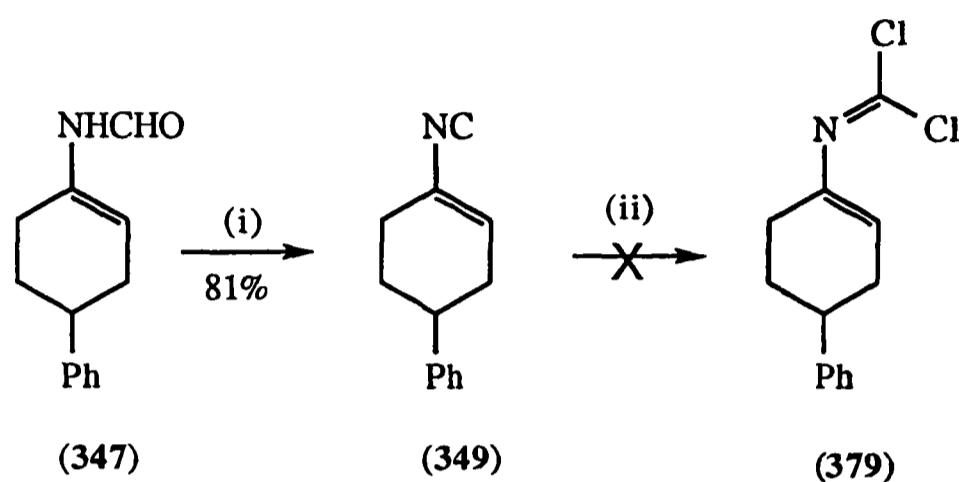

(i) Tf_2O (1.5 eq.), $^i\text{Pr}_2\text{EtN}$ (3 eq.), DCM, -78°C , 20min.;
(ii) Cl_2 , CCl_4 .

Scheme 97

As the radical chlorination of the benzyl-CH was viewed as a potential problem with this substrate, the *t*-butyl substituted vinyl isonitrile (**383**) was prepared in three steps from ketone (**380**) in an analogous manner to (**349**), Scheme 98. Again a number of products were obtained on attempted formation of (**384**). Potential problems were considered to be side chain chlorination or hydrolysis of the dichloroimine by adventitious water but despite the addition of radical inhibitors (*e.g.* 3-*t*-butyl-4-hydroxy-5-methylphenyl sulfide²⁷² or by saturation of the solution with oxygen), attempts to dry the chlorine solution and to remove any traces of HCl that may be generated in the reaction, by the addition of propylene oxide, clean chlorination could not be effected.

To reduce the possibility of side chain chlorination the naphthyl vinyl isonitrile (**388**) was prepared, Scheme 99.¹⁵² On attempted chlorination a mixture of products were again obtained one of which was ketone (**385**). It was argued that over-chlorination may be occurring due to the difficulty in accurately determining the concentration of the chlorine solution. Iodobenzene dichloride (**390**) (prepared from iodobenzene and chlorine),²⁷³ a

crystalline solid that behaves as a source of chlorine was also examined in this rôle but gave similar results. Hence, the model studies were abandoned.

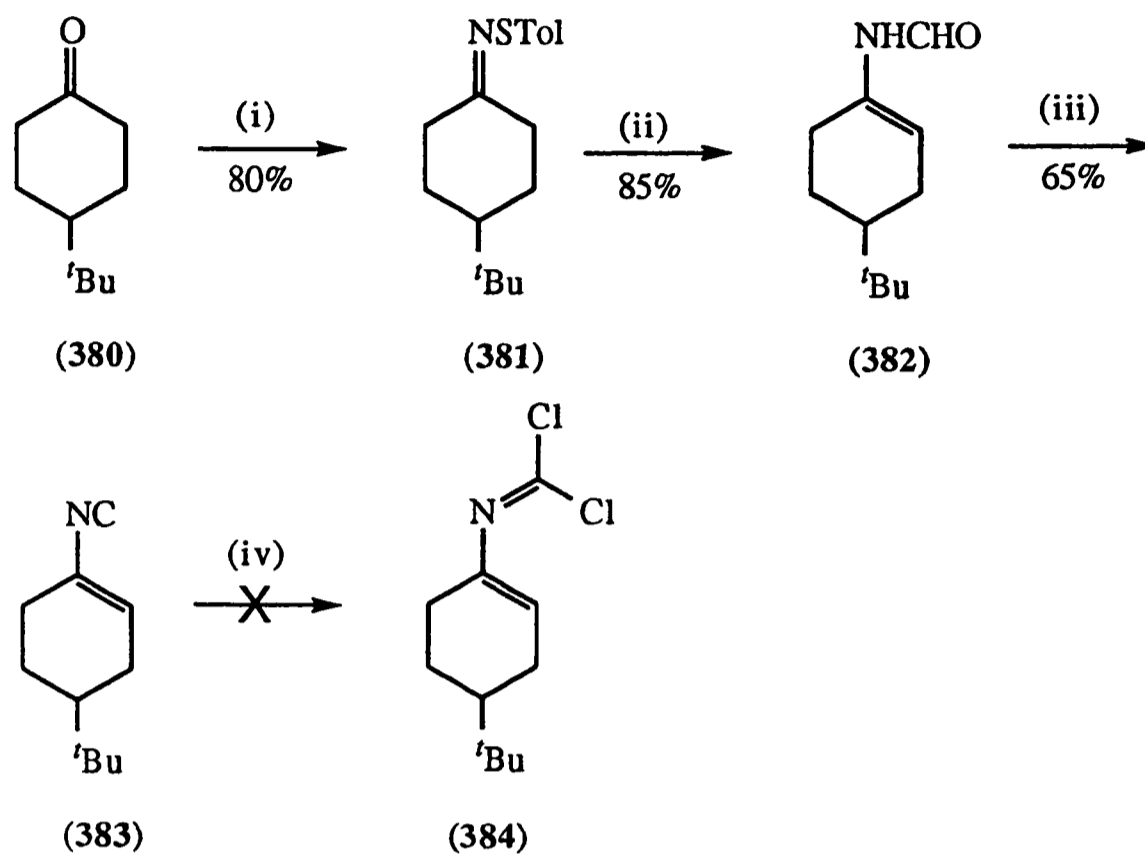

(i) TolSN(TMS)₂ (1.1 eq.), TBAF (cat.), THF; (ii) PPh₃ (3 eq.), AcOCHO (3 eq.), propylene oxide, DCM, RT, 24h.; (iii) Tf₂O (1.5 eq.), ⁱPr₂EtN (3 eq.), DCM, -78°C, 20 min.; (iv) Cl₂, CCl₄.

Scheme 98

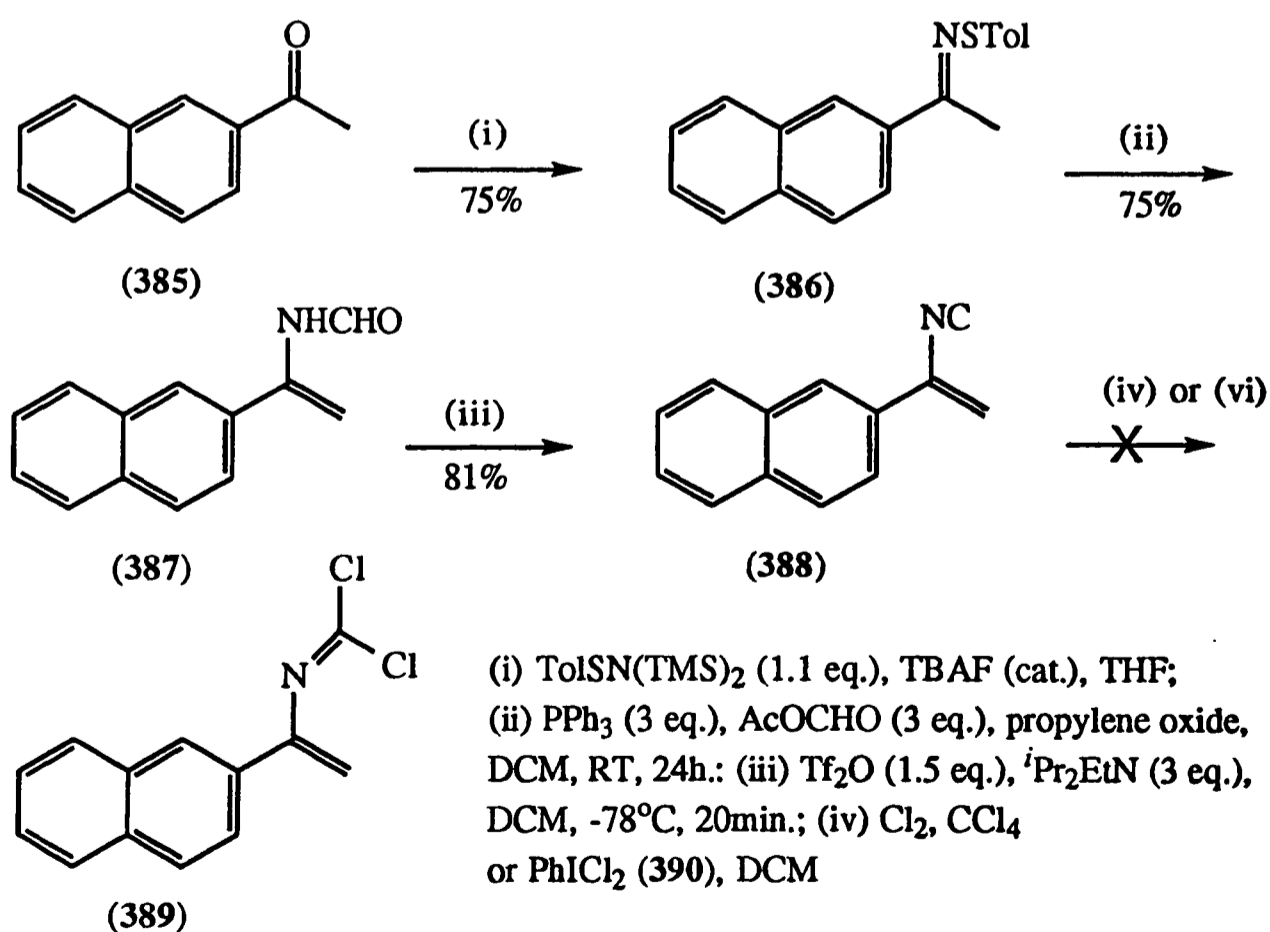

Scheme 99

Chlorination of isonitrile (325) (as a single epimer at the secondary alcohol centre) was successful with Cl_2/CCl_4 but found to be capricious. On the few occasions when dichloroimine (391) was formed as the sole product attempts were made to remove the chlorine atoms to regenerate the isonitrile. As previously mentioned triphenylphosphine has been utilised for this purpose but vigorous conditions are necessary.¹⁸⁷ Trichoviridin is known to be decomposed on heating and it was felt that (325) and the corresponding epoxide were also likely to be sensitive to these conditions. Thus, the milder cathodic reduction,¹⁸⁸ Section 2.2.4 was examined but proved unsuccessful, although this may be a result of the practical difficulty in carrying out this procedure, in particular maintaining the dry state of the solvents. Hence, due to the difficulty of forming dichloroimine (391), which severely restricted the development of subsequent chemistry, alternative isonitrile "masking groups" were sought.

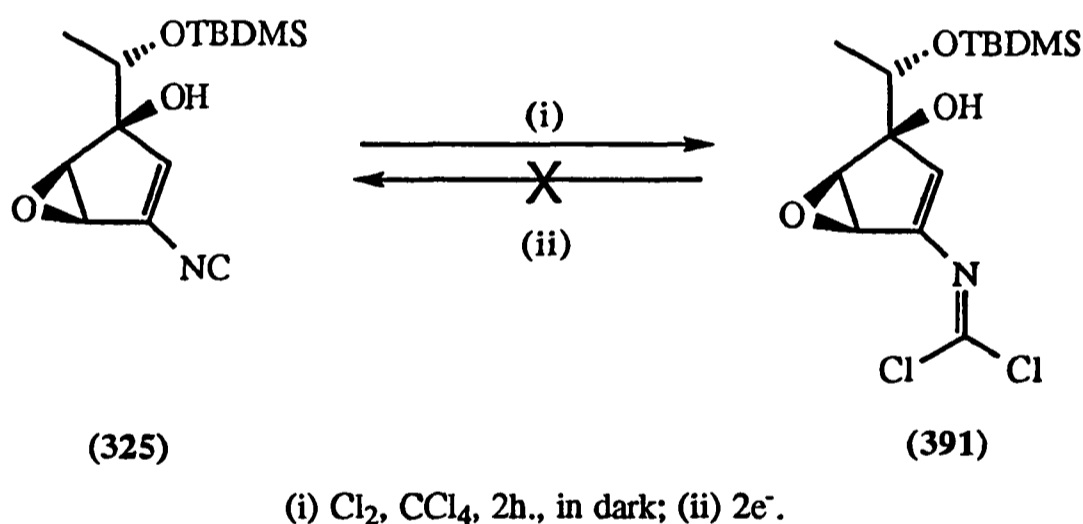

Scheme 100

4.5.5.2 Photolabile "Protecting Groups" for Isonitriles

In the search for a "protecting group" for the isonitrile that could be removed under mild conditions, the possibility of preparing and utilising two groups that were potentially photolabile was investigated. Firstly, sulphenyl chlorides are known to react with isonitriles in an α -addition sense to generate isothiocarbamoyl chlorides (393) Scheme 101.¹⁸⁷



Scheme 101

It was noted that Barton had utilised a 2,4-dinitrobenzenesulfonyl ester (394) to generate the corresponding carboxylic acid in good yield under photolytic conditions, Scheme 102.²⁷⁴⁻²⁷⁶ Although there was some debate as to whether the intermediates were radical or ionic in character the use of this group in this manner suggested the related isothiocarbamoyl chloride (R'=2,4-dinitrosulfonyl, Scheme 101) as a potential photosensitive protecting chromophore for the isonitrile function. The nucleophilic replacement of the remaining chlorine with 2,4-dinitrothiophenol to form a dithioimine was also a possibility.¹⁸⁷

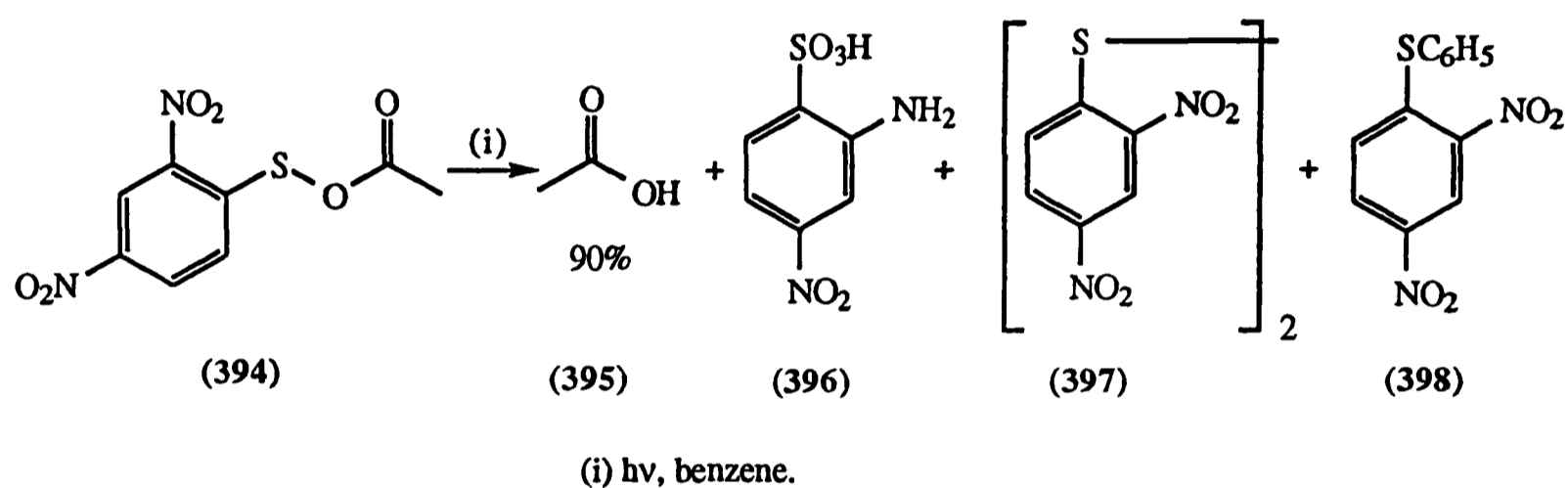

Scheme 102

2,4-Dinitrosulfonyl chloride added smoothly to both isonitriles (383) and (325)^{277,278} to generate (399) and (400) respectively, present as single geometric isomers. These compounds were relatively stable and could be purified by flash chromatography. However, attempts to regenerate the corresponding isonitrile from either (399) or (400), by photolysis with a medium pressure mercury lamp, resulted in decomposition to products which were insoluble in a range of organic solvents, Scheme 103.

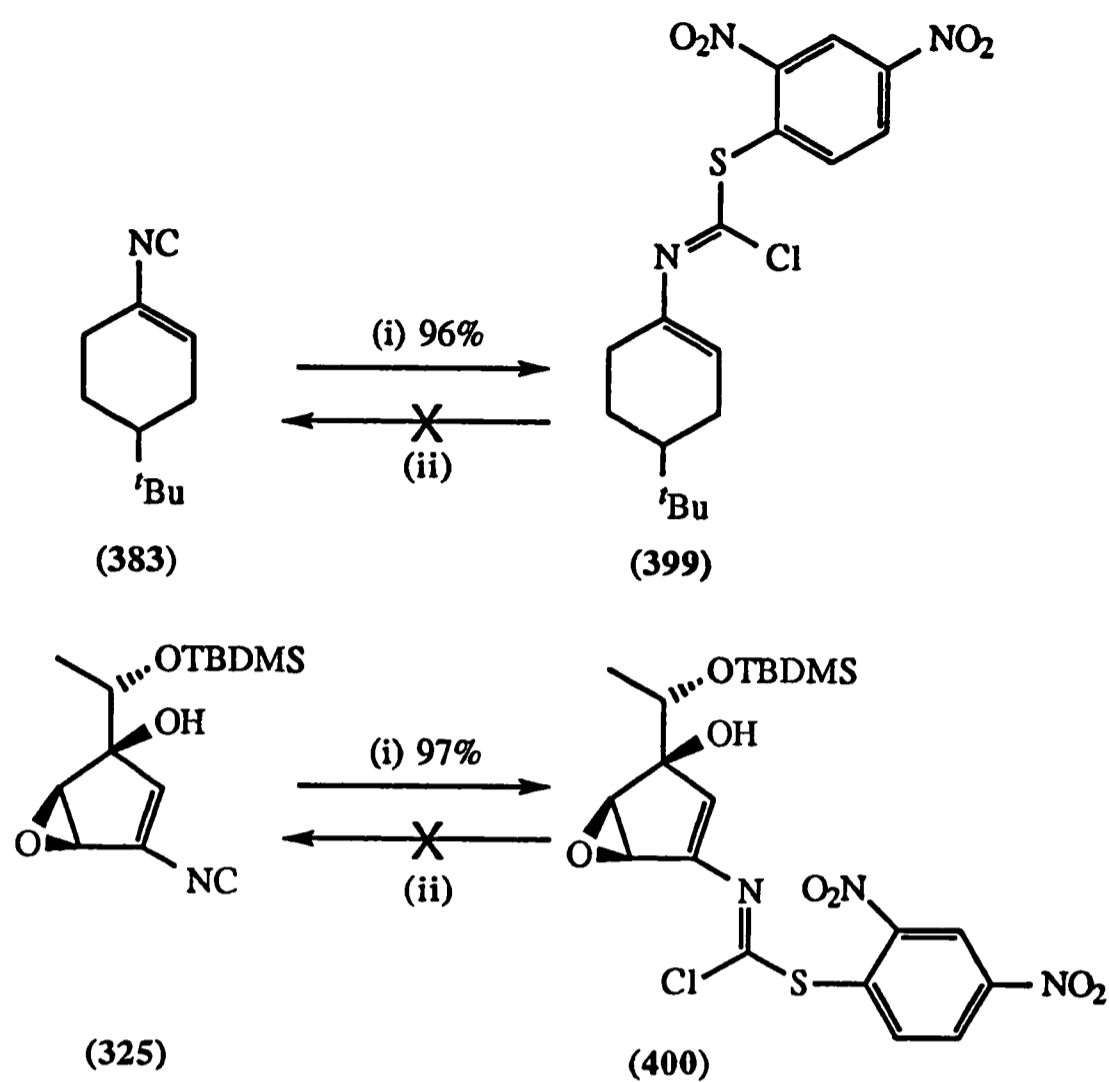

(i) 2,4-dinitrosulfonylchloride (1 eq.), propylene oxide, DCM, -40°C to RT, 1h.;
(ii) hv, benzene.

Scheme 103

Secondly, it was postulated that species such as (401) where R' is for example (403), would on generation of the appropriate radical intermediate, lead to the loss of (402) and carbon dioxide to afford the desired isonitrile, Scheme 104

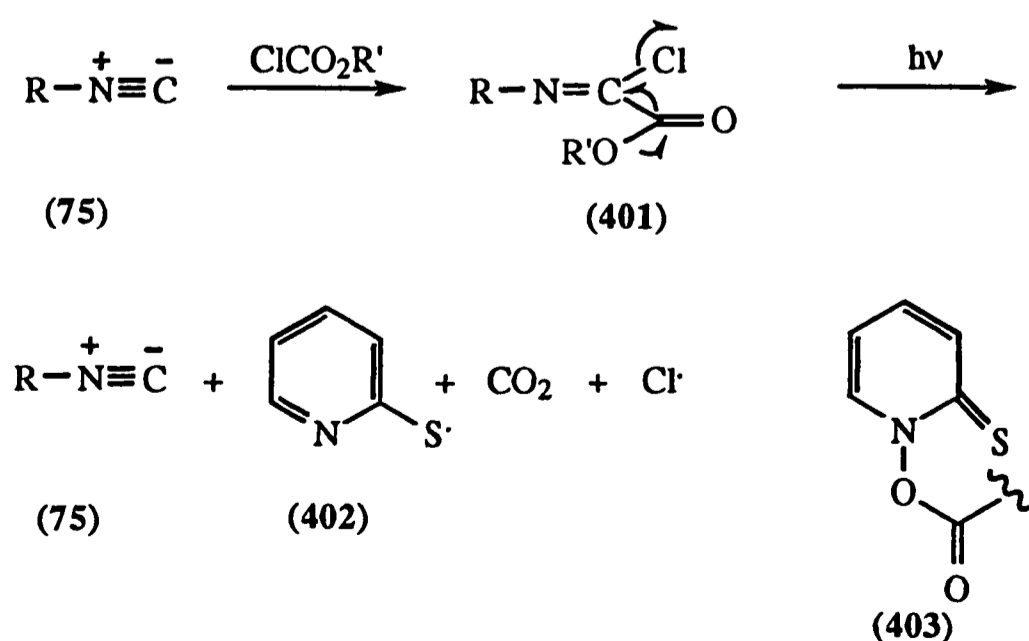

Scheme 104

Such species could potentially be generated by the addition of the appropriate chloroformate to an isonitrile. Despite the fact that the α -addition of acid chlorides to isonitriles is well established,²⁷⁹ the corresponding reaction with chloroformates is unknown. Model studies with simple chloroformates were therefore conducted. Chloroformates would be expected to add more slowly than acid chlorides and indeed no reaction between benzylchloroformate and (347) was observed on prolonged stirring or on heating, Scheme 105.

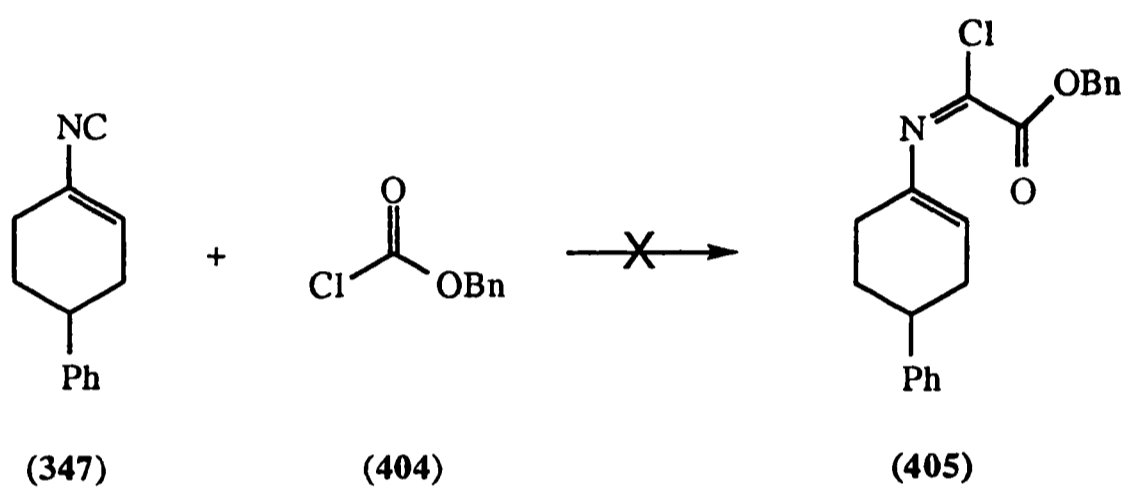

Scheme 105

Palladium catalysis has been used to effect Stille cross coupling reactions of chloroformates with stannanes²⁸⁰ and furthermore, Ito *et al.* recently reported that palladium catalysis allowed for the *bis*-metalation of isonitriles with organosilylstannanes.²⁸¹ Hence, it was postulated that the α -addition of chloroformates to isonitriles would be more facile in the presence of palladium. However, no addition of benzylchloroformate to (347) was observed in the presence of $\text{Pd}(\text{PPh}_3)_4$ and as other routes were showing more promise, this work was abandoned.

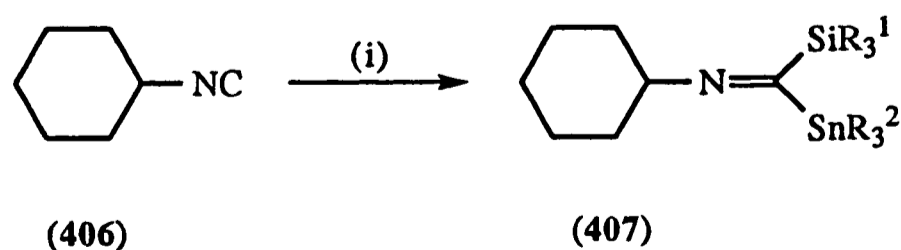

(i) $\text{Pd}(\text{PPh}_3)_4$ (cat.), $\text{R}_3^1\text{SiSnR}_3^2$, toluene, 60°C.

Scheme 106

4.5.5.3 The Dibromoimine as an Isonitrile "Protecting Group"

It was postulated that the removal of bromine atoms would be more facile than the removal of chlorine atoms from the relevant dihaloimine. Bromination of vinyl isonitriles with a solution of bromine in carbon tetrachloride has been shown to result in decomposition possibly as a result of the difficulty in drying this solution or due to competitive attack at the double bond with the more reactive and less discriminating bromine.²⁸² On this basis alternatives were sought and it was discovered that formation of dibromoimine (or carbonimidic dibromide) (**408**) could be effected using polymer supported bromine (Amberlyst A-26 Br₃⁻ form), as a source of dry bromine of known concentration,²⁸³ in the presence of propylene oxide as an acid scavenger, Scheme 107. The lower reactivity associated with Br₃⁻ may also have had a part to play. Dibromoimine (**408**) was found to be acid and moisture sensitive and was therefore used directly in subsequent reactions.

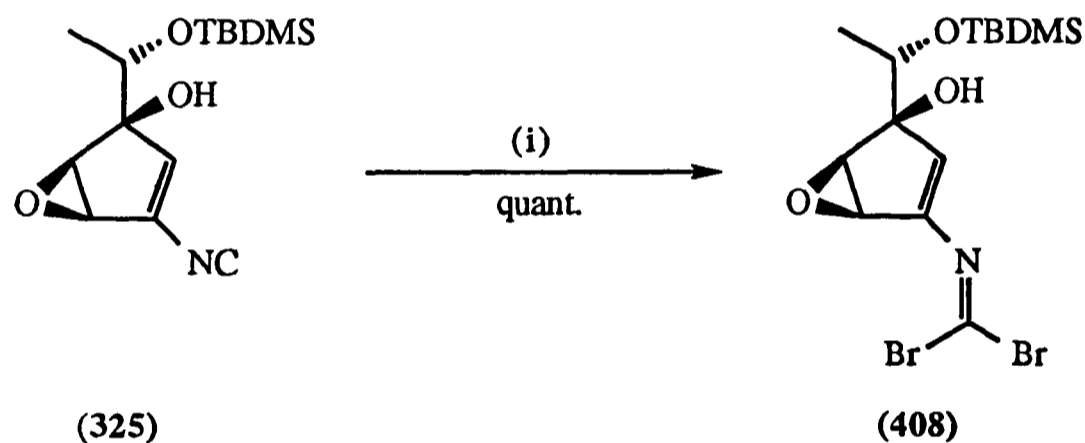

(i) polymer supported Br₂, propylene oxide, DCM, RT, 2h., in dark.

Scheme 107

Of interest is the fact that bromination of the model systems (**347**), (**383**) and (**388**) remained problematic even with this reagent. Similar studies carried out during the attempted synthesis of the epoxy-isonitrile aerocyanidin (**70**) have shown that the electron density of the double bond is critical to the outcome of this reaction.²⁸² Only with electron deficient double bonds (as in (**325**)) can vinyl dibromoimines be formed cleanly. With relatively electron rich double bonds bromination of the C-C double bond competes with bromination of the isonitrile moiety.

Before epoxidation of (408) was attempted, methods of removing the bromine atoms were examined. Encouraged by the success enjoyed by Professor Barrett in dechlorinating epoxy-dichloroimines we first looked at removal of the bromine atoms using a tin hydride reagent. Tin hydrides are often used for the reductive removal of bromine atoms in organic synthesis.²⁸⁴ The radical chain process is usually efficient and furthermore, the remaining functional groups of (408) or the corresponding epoxide would be expected to be stable under these conditions. Although isonitriles may themselves be removed with tin reagents, a procedure which is often used for the deamination of sugars, vigorous conditions are required unless the radical generated is tertiary and even then the chain process, if involved, is inefficient.²⁸⁴ A radical generated on deamination of (408) or the corresponding epoxide would be relatively unstable and thus it was hoped that this unwanted reaction would not be a problem. Treatment of (408) with triphenyltinhydride, chosen for its relatively high reactivity for an organostannane, with AIBN in refluxing benzene resulted in only a trace of (325) being formed. Under low temperature photolytic conditions, however, a recovery of 80% of (325) was achieved although the often encountered problems associated with the purification of compounds derived from procedures involving tin reagents were soon evident, with at least two flash columns being required to remove all the tin residues.

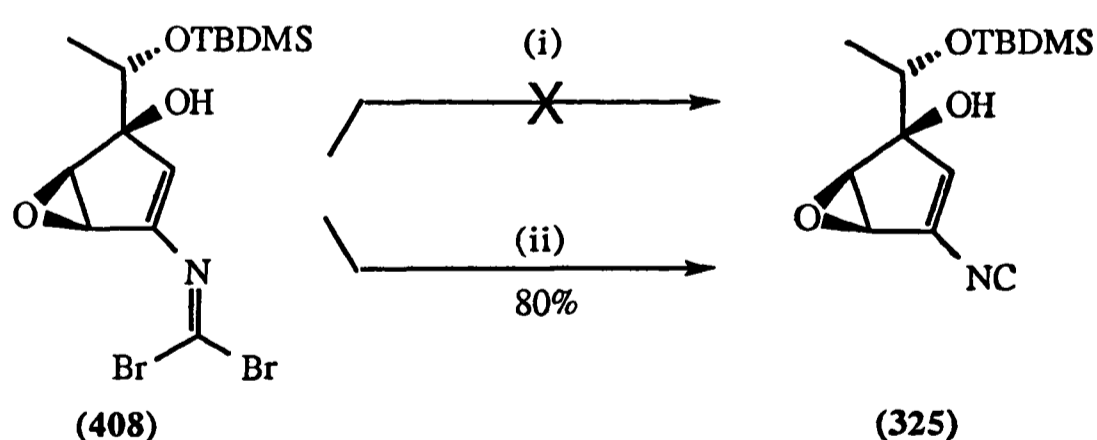

(i) Ph₃SnH, AIBN, PhH, reflux; (ii) Ph₃SnH, hv, AIBN, PhH, 0°C, 1h.

Scheme 108

The preferred option of using phosphorus (III) reagents was then examined. While mindful of the likely reactivity of the Ph₃PBr₂ which would be generated on reaction of Ph₃P with (408) this course was nonetheless pursued with the aim of eventually substituting

polymer supported PPh_3 to simplify purification. While reaction was fairly rapid (twenty minutes at ambient temperature) it was accompanied by total decomposition of the product. Triethylphosphite was then examined in this rôle and it was found that stirring a mixture of (408) and $\text{P}(\text{OEt})_3$ at room temperature for one hour resulted in the regeneration of isonitrile (325) in an excellent 82% yield following a straightforward isolation procedure. The success of this reagent may not only lie in its enhanced nucleophilicity over triphenylphosphine but also that an Arbusov type reaction is possible which would generate $\text{O}=\text{P}(\text{OEt})_2\text{Br}$ and ethyl bromide, potentially less reactive by-products, Scheme 109.

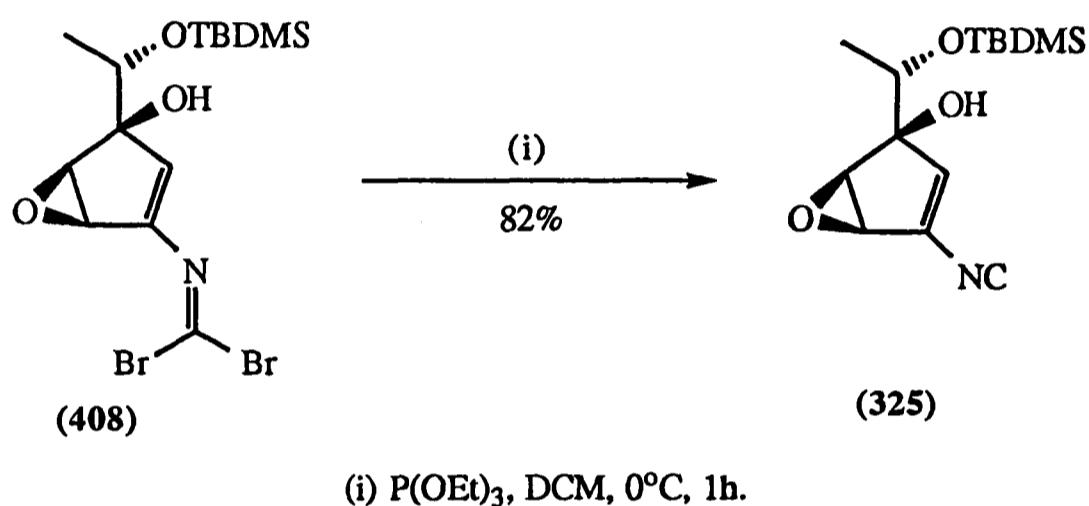

Scheme 109

With efficient addition and removal of the isonitrile "protecting group" now possible, the feasibility of the epoxidation of (408) needed to be ascertained. Compared to vinyl formamide (319) the electron density of the double bond of (408) is further reduced and thus it was felt that the more reactive dioxirane, methyl(trifluoromethyl)dioxirane would be required to effect epoxidation. Again it was hoped that epoxidation would take place primarily *anti* to the tertiary hydroxyl for the reasons already specified (*vide supra*). To a solution of (408) and propylene oxide at -40°C in dichloromethane was added the methyl(trifluoromethyl)dioxirane solution in batches until t.l.c. analysis indicated that the dibromoimine (408) had been consumed.[†] The resulting mixture of products were immediately subjected to treatment with either triethylphosphite or triphenyltinhydride. In each

[†] T.l.c. of dibromoimine (408) gives a number of spots which result from decomposition. It is the disappearance of one of these spots which determines the progress of the reaction.

case just one epoxy isonitrile (**409**) was obtained as a colourless oil (after purification by flash chromatography). With triethylphosphite a yield of 18% of (**409**) from (**325**) was achieved over three steps which was marginally superior to that obtained for the corresponding series involving triphenyltinhydride, with the use of the phosphite again facilitating purification, Scheme 110.

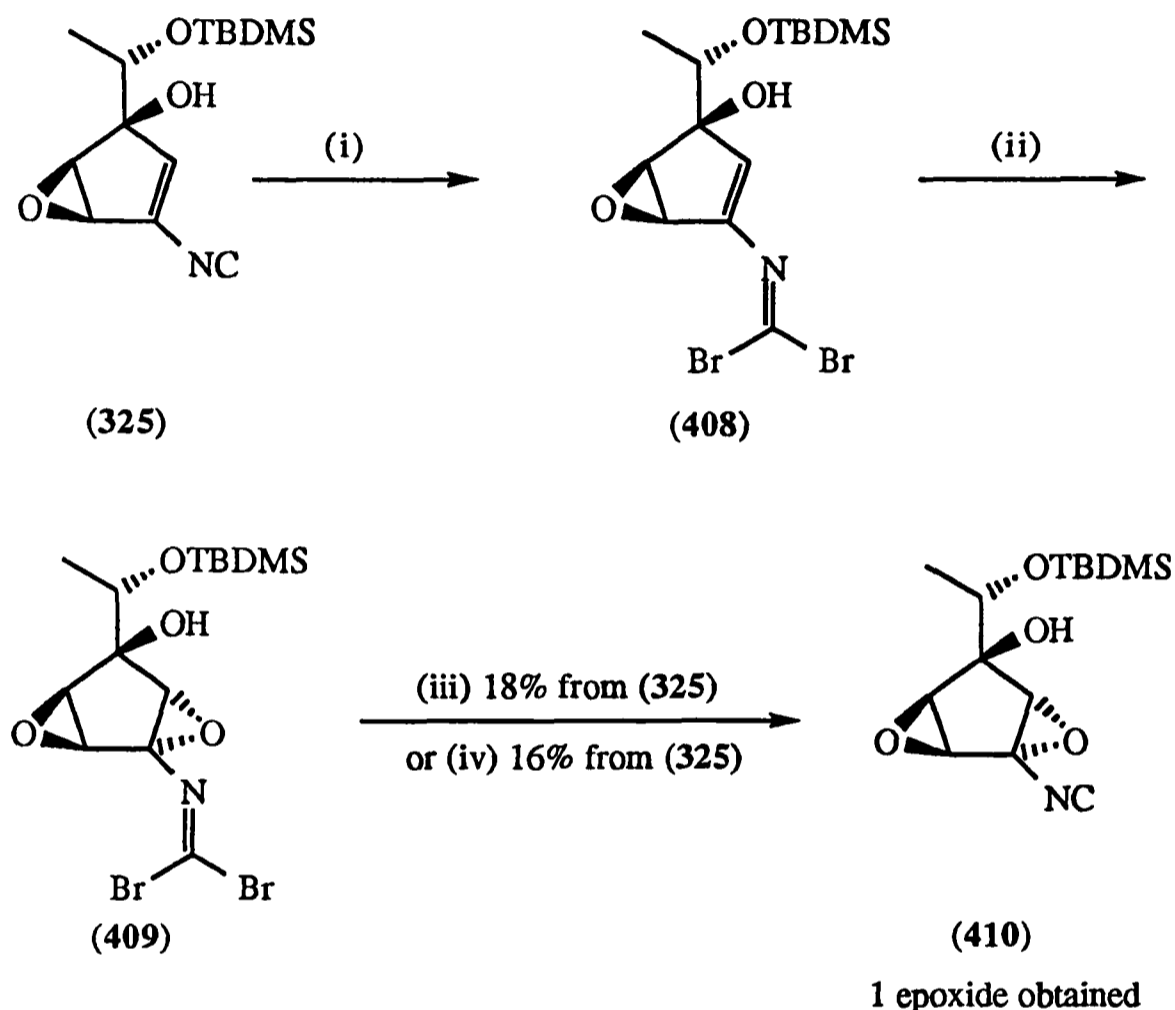

(i) polymer supported Br₂ (1 eq.), propylene oxide (10 eq.), DCM, RT, 2h., in dark;

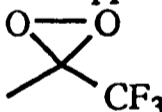
(ii) , propylene oxide, -40°C, DCM;

(iii) P(OEt)₃ (10 eq.), RT, 1h.; (iv) Ph₃SnH (5 eq.), hv, AIBN (cat.), PhH, 0°C, 1h.

Scheme 110

The stereochemistry of the new epoxy group of (**410**) could, unfortunately not be determined by n.O.e. studies and hence deprotection of (**410**) was attempted. Brief treatment of (**410**) with TBAF in THF gave a crystalline compound whose ¹H n.m.r. appeared to be in agreement with that reported for trichoviridin (**16**), Scheme 111. That (±)-trichoviridin was indeed the product of these reactions was established by mixed ¹H n.m.r. with the natural

material, Figure 18. The first synthesis of this extremely complex small molecule has, therefore, been achieved in an overall yield of 3% from fulvene (327).

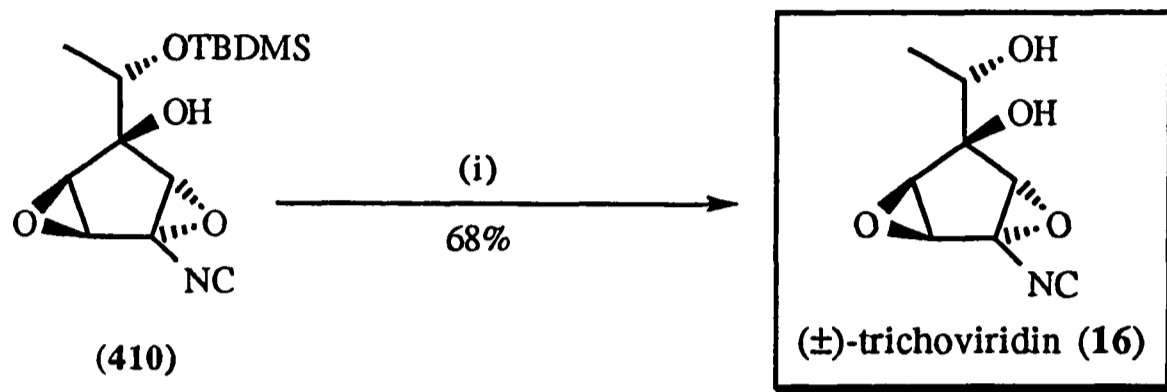

(i) TBAF (1.15 eq.), 0°C, THF.

Scheme 111

The stereochemical outcome of the epoxidation is worthy of further discussion. As the yield of (410) from (325) is modest, primarily as a result of the epoxidation step, the formation of the alternative epoxide (411) cannot be completely ruled out. That (411) was not isolated may be a result of its more facile decomposition (perhaps as a result of H-bonding of the tertiary hydroxyl to the epoxide group). Indirect evidence has, however, been obtained that suggests that the epoxidation is in fact stereospecific. The series of reactions in Scheme 110 was initially carried out on isonitrile (325) as an isomeric 6:1 mixture at the secondary alcohol centre. Epoxidation of the corresponding dibromoimines indicated that whilst the major isomer was consumed rapidly, the minor isomer reacted slowly if at all. Modelling studies, Figure 19, have shown that the α -face of the minor isomer is sterically more congested than that of the major isomer. If the β -face was accessible it would be anticipated that the minor isomer would be consumed *via* epoxidation to give the β -stereoisomer and thence to decomposition products.

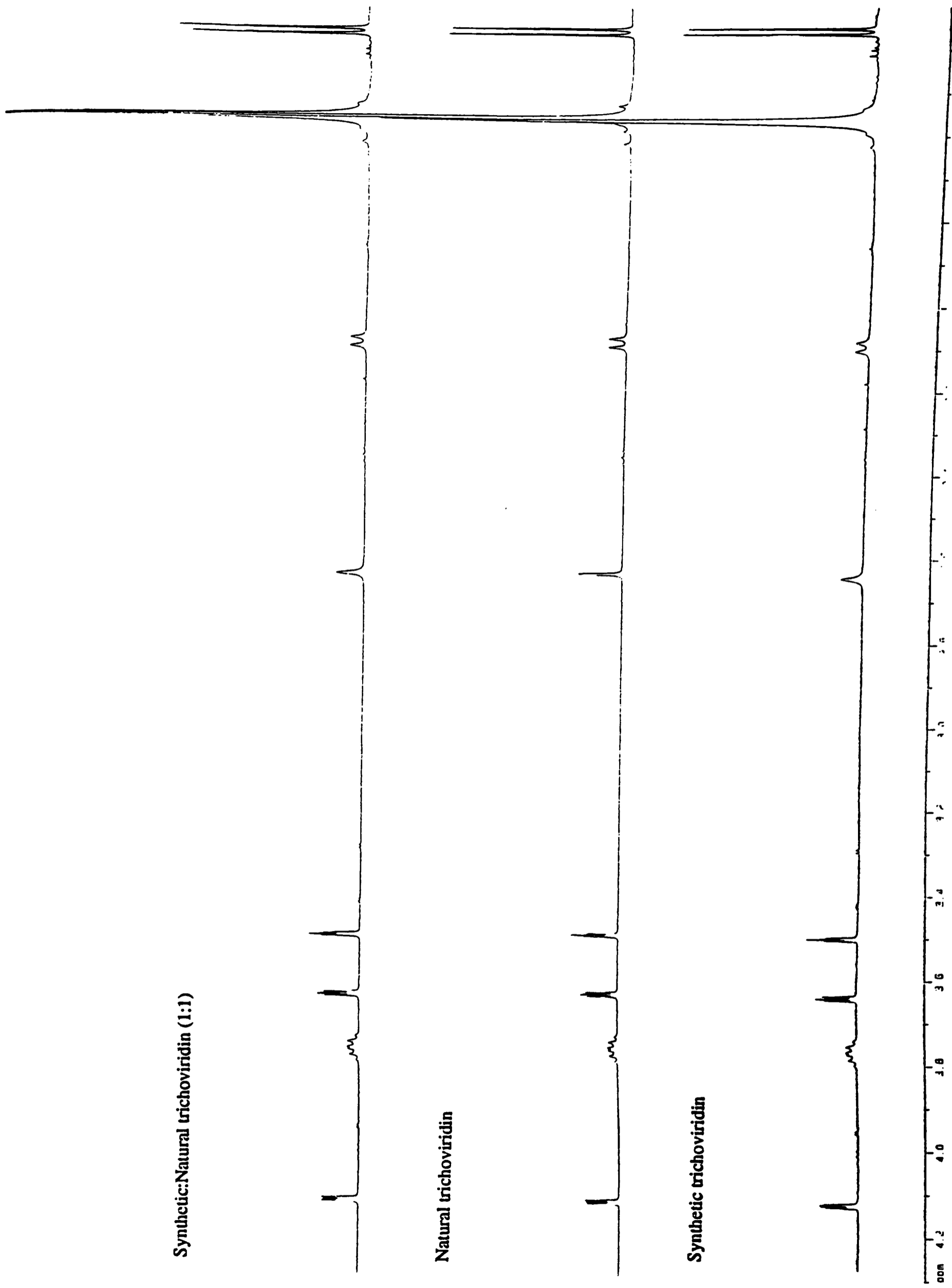
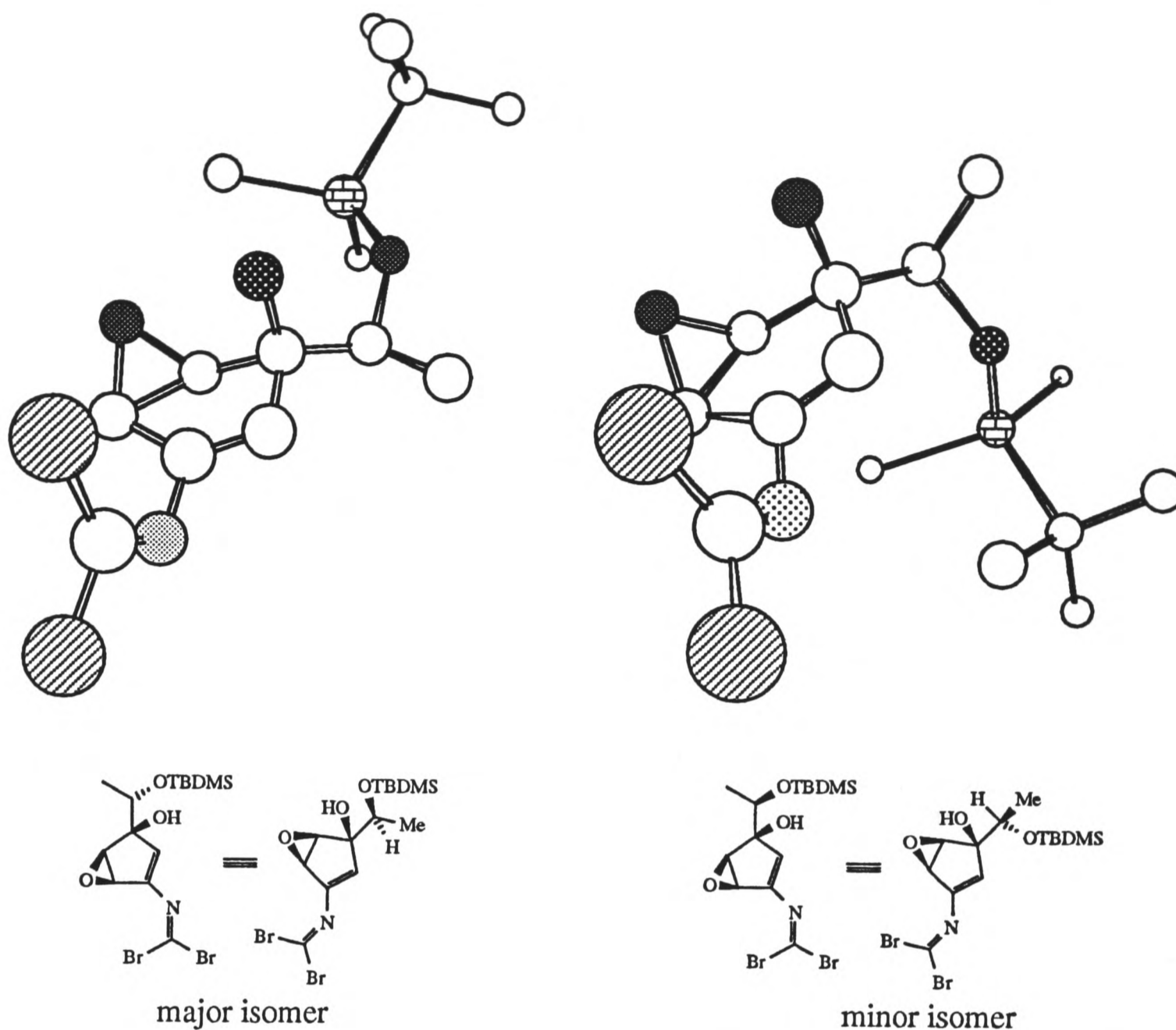

Figure 18



Models of dibromoimines (hydrogen atoms not shown for clarity). Minimised using a first derivative method followed by an Adopted-Basis Newton-Raphson algorithm using Quanta version 4.0. Figures produced using CCS Chemdraw version 3.0b2.

Figure 19

Chapter 5

Mechanism of the Thiooxime Rearrangement

5.1 Introduction

Ever since the conception of the thiooxime rearrangement, Section 2.2.2, there has been much debate as to the mechanism by which it proceeds. As discussed previously, simple thiooximes such as (137) rearrange directly to the corresponding vinyl formamide. It was originally proposed, therefore, that this rearrangement progressed as indicated in Scheme 112 *via* the intermediacy of the α -thioformamide (130) (along a comparable pathway to that postulated by Gordon,²¹³ Scheme 42, where complexation between triphenylphosphine and the thiooxime precede formylation). The α -thioformamide was believed to break down to generate vinyl formamide (132) *via* imine (414) that underwent subsequent tautomerisation.²¹⁵

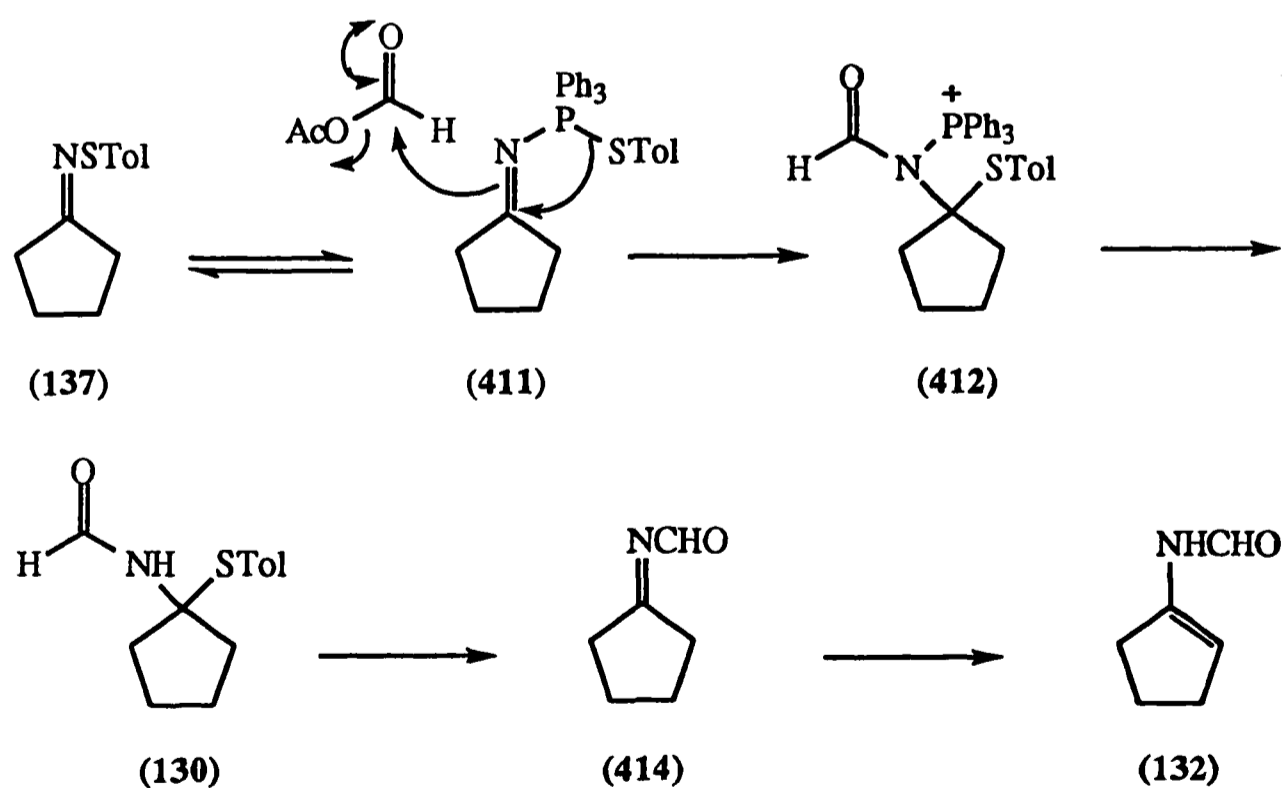

Scheme 112

With a number of complex cyclopentyl thiooximes *e.g.* (415) and (416), Scheme 113, O'Neil had obtained α -thioformamides as products following treatment with triphenylphosphine and acetic formic anhydride. Furthermore, O'Neil showed that it was not possible to transform these α -thioformamides to their corresponding vinyl formamides by further exposure to the rearrangement conditions. Hence at this stage, it was unclear whether α -thioformamides were intermediates in the formation of vinyl formamides or products of competing reactions.

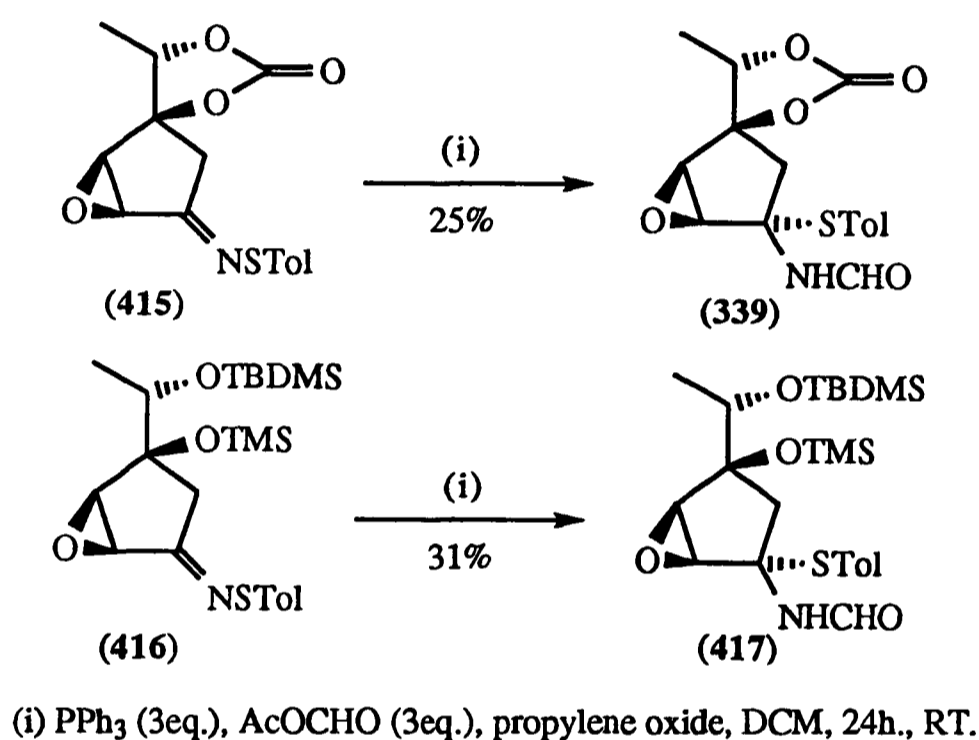

Scheme 113

The intermediacy of an *N*-formylimine was also in question. It was noted that Barton had obtained the thermodynamically more stable vinyl formamide (128) when using his methodology on the oxime (127), Section 2.2.2.¹⁴⁹ Barton suggested that the formation of vinyl formamides from oximes with titanium (III) acetate and acetic formic anhydride proceeds through the intermediacy of an imine which underwent formylation to the *N*-formylimine which then tautomerises to the more thermodynamically more stable vinyl formamide. The observation that thiooxime (418) rearranges with triphenylphosphine and acetic formic anhydride to the vinyl formamide with the least substituted double bond (*i.e.* the kinetic product) cast some doubt on the intermediacy of the corresponding *N*-formylimine as it had been expected that such an intermediate would undergo tautomerisation to the

thermodynamically more stable vinyl formamide. However, it was not possible to completely discount an *N*-formylimine as an intermediate as it was plausible that equilibration of the vinyl formamide was possible under the Barton conditions but not in our case.

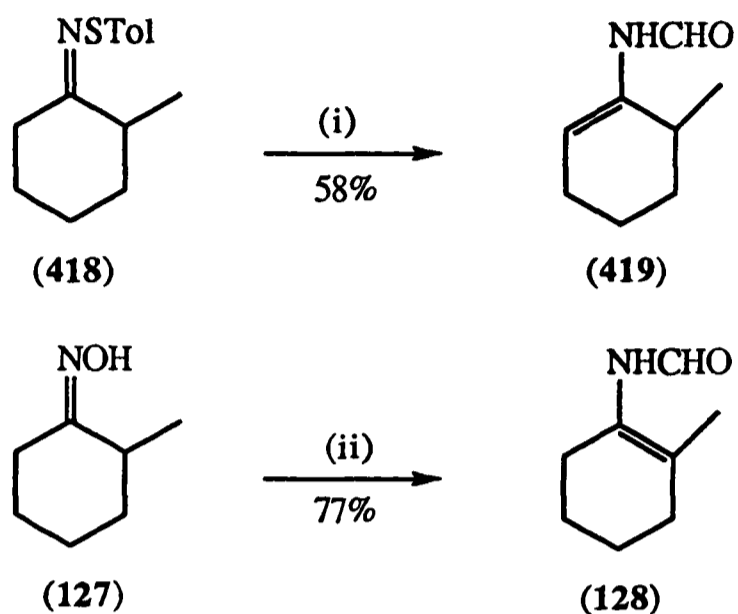

(i) PPh_3 (3eq.), AcOCHO (3eq.), propylene oxide, DCM, 24h., RT;
(ii) $\text{Ti}(\text{OAc})_3$, AcOCHO , MeCN, 6h., 60°C .

Scheme 114

A number of alternative mechanisms were therefore proposed as indicated in Scheme 115.²¹⁵

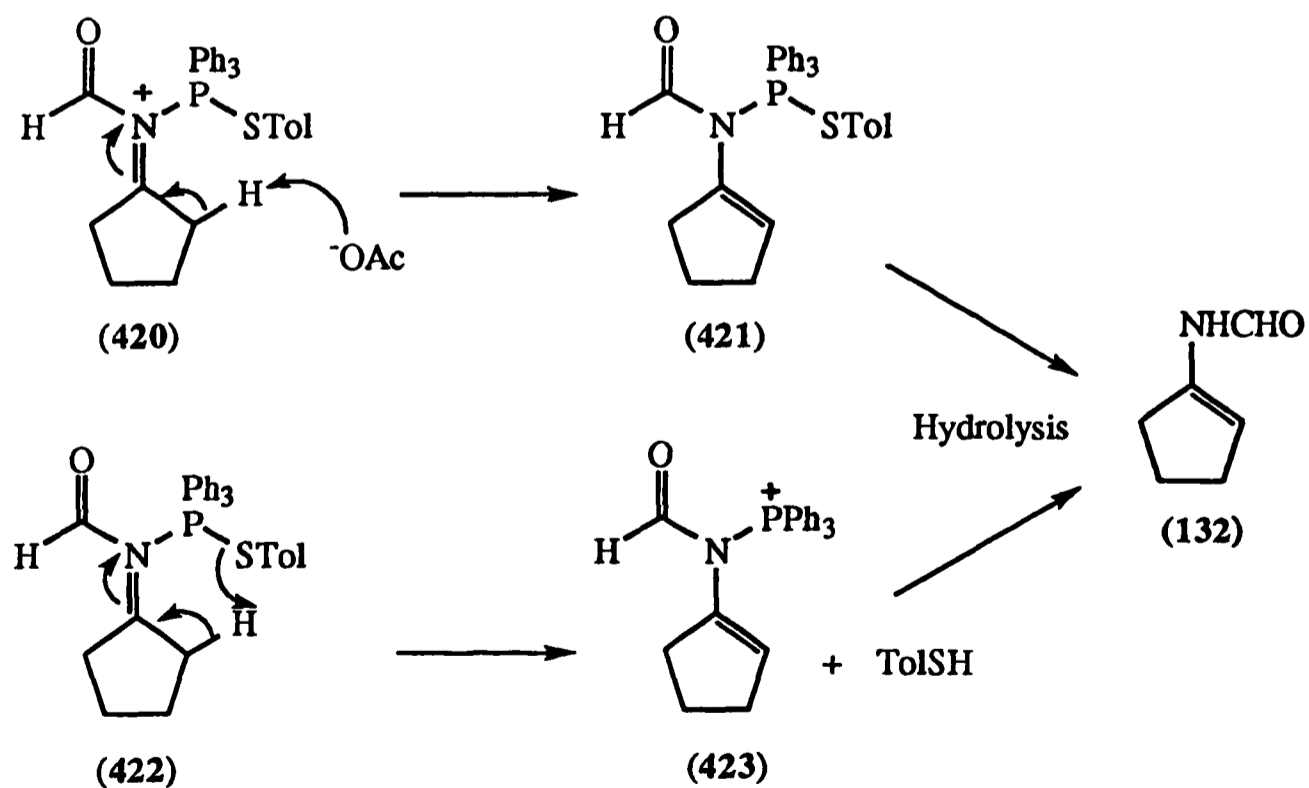

Scheme 115

The more recent observations that the valine derived thiooxime (257) and the cyclopentyl thiooxime (324) delivered α -acetoxyformamides were, however, not readily addressed any of the above mechanisms.

5.2 Summary of Previous Work

In a preliminary study, by this author, designed to elucidate the mechanism of this fascinating rearrangement a number of ^{31}P and ^1H n.m.r. experiments were conducted.²¹⁶ In the hope of understanding the differing behaviour of the variously substituted thiooximes that have been examined in recent years in this laboratory two substrates were chosen for this study, specifically the naphthyl substituted thiooxime (133) which was known to rearrange to the corresponding vinyl formamide and the valine derived thiooxime (257) which delivers the corresponding α -thioformamide and α -acetoxyformamide, Figure 20.

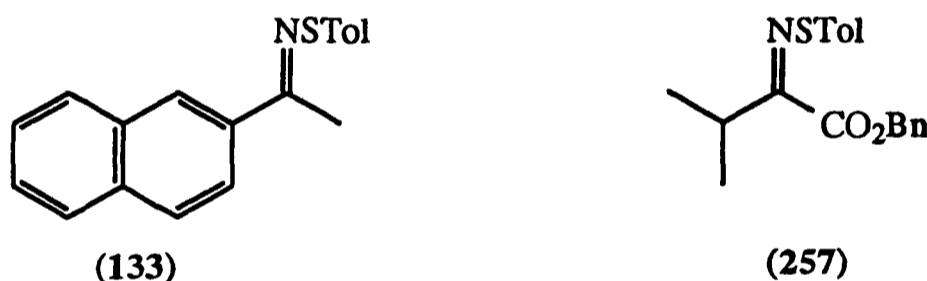
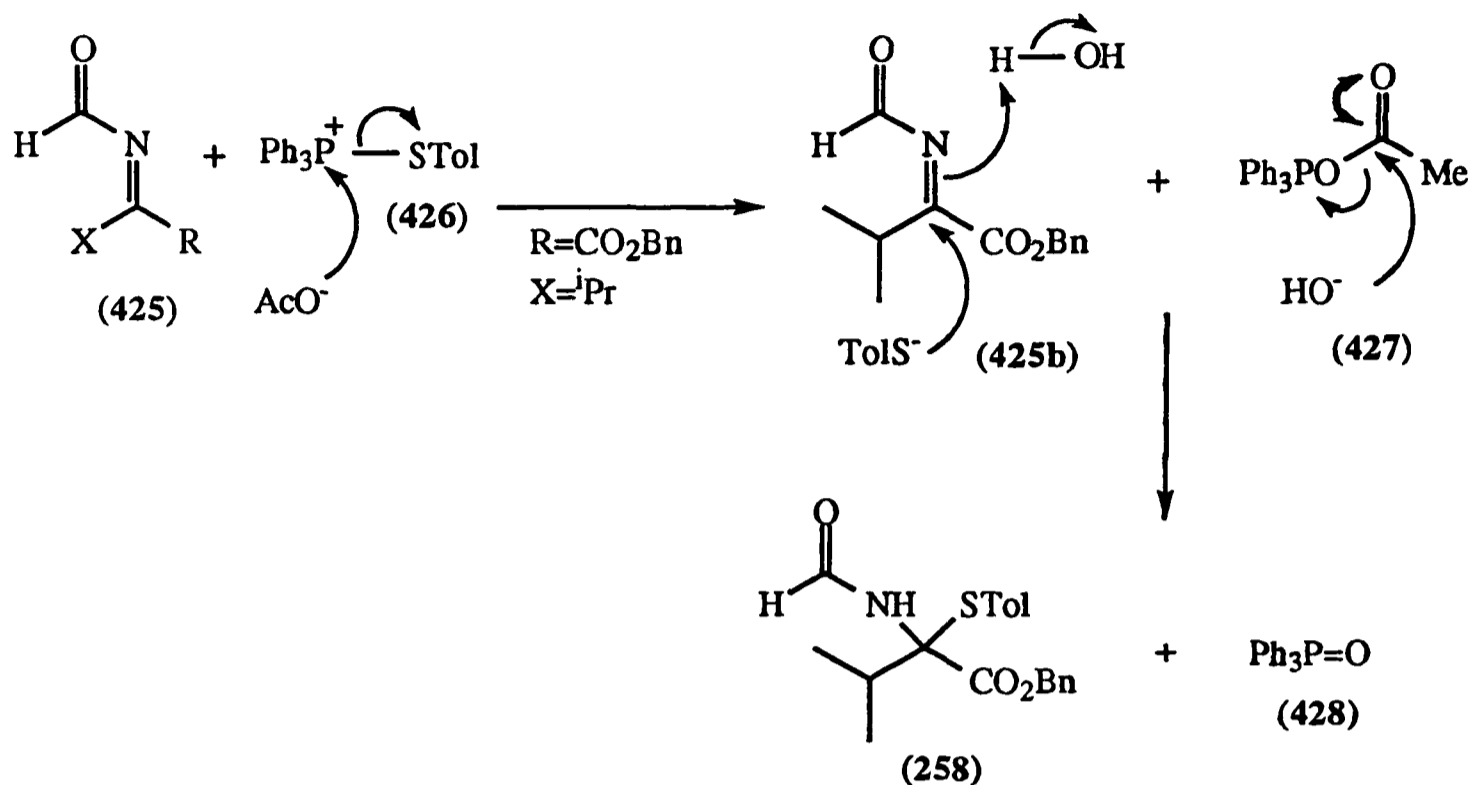

Figure 20

No evidence was obtained for the phosphine insertion complex, proposed by Gordon,²¹³ with no change being observed in either the ^{31}P or ^1H n.m.r. on mixing (133) or (257) with triphenylphosphine prior to the addition of acetic formic anhydride. This was consistent with observations made by Mukaiyama during his related studies of the cleavage of the N-S bond of sulfenamides whereby he observed no cleavage of this bond in the absence of a proton source such as water or alcohol.²⁸⁵ Evidence was, however, obtained for the intermediacy of an *N*-formylimine in that rapid conversion of either (133) or (257) to intermediates with signals in the ^1H n.m.r. consistent with the corresponding imine structures were observed following the addition of acetic formic anhydride along with the concomitant appearance of triphenylphosphine oxide (by ^{31}P and ^1H n.m.r.). This was followed by the

Alternatively direct formation of α -thioformamide;



Scheme 116 cont.

Initially formylation occurs followed by cleavage of the N-S bond to give an *N*-formylimine which then tautomerises more or less slowly depending on the nature of the substituents of the imine carbon. It was believed that for thiooxime (133), in analogy with Mukaiyama,²⁸⁵ displacement of the thiotolyl group occurs followed by re-attack on the acyloxyphosphonium salt to deliver triphenylphosphineoxide (428) and thioester (429). In the case of the valine derived thiooxime (257) the varying amounts of α -thioformamide and α -acetoxyformamide needed to be accounted for. Attack of TolS^- and AcO^- in the Michael sense to the *N*-formylimine is not unreasonable but in the absence of adventitious water it was difficult to account for the absence for a long lived phosphorous species in the ^{31}P n.m.r. Either a phosphonium salt or a five valent phosphorous (V) species would have been expected to have a resonance in a markedly different position to either triphenylphosphine or triphenylphosphine oxide.²⁸⁶ Thus we were forced at this stage to conclude that because of the very slow reaction water is entering the system to mediate triphenylphosphine oxide formation.

5.3 ^{13}C n.m.r. Experiments and Elucidation of Reaction By-products

As mentioned previously Gordon had based his evidence for the phosphine insertion complex on the shift of the tolyl methyl signal of the cephalosporin thiooxime (252) in the ^{13}C n.m.r. spectra that occurred following the addition of triphenylphosphine.²¹³ Hence, to determine with more certainty that phosphorous insertion into the N-S bond was not taking place with (133) and (257) their rearrangements were monitored by ^{13}C n.m.r (50MHz). Thus (133) and (257) were dissolved in anhydrous CD_2Cl_2 such that the concentration of the thiooxime was approximately equal in each case and one equivalent of triphenylphosphine was added. From the ^{13}C n.m.r. spectra no evidence was obtained for the phosphine insertion complex, in agreement with the ^{31}P and ^1H n.m.r. experiments above. Firstly considering the naphthyl thiooxime (133); upon the addition of two equivalents of acetic formic anhydride rapid consumption of the thiooxime (133) was observed with the concomitant appearance of resonances at 176.1 p.p.m. but no resonances corresponding to vinylic carbons ($\delta\text{C} = 101.1$ and 103.8 p.p.m.) of the product vinyl formamide. After a delay of five hours the resonances at 176.1 p.p.m. had disappeared and substantial amounts of vinyl formamide could be seen. Analysis of the ^{13}C n.m.r. of the valine derived thiooxime (257) was more complex. Slow disappearance of the starting material was noted with the appearance of a signal at 174.3 p.p.m. Slower formation of signals consistent with α -thioformamide and α -acetoxyformamide were then observed. No evidence was seen for the formation of vinyl formamide even after forty-eight hours. Thus, further evidence for the intermediacy of *N*-formylimine (425) was obtained in each case. It is proposed therefore that the formation of the kinetic product from (418) *via* the Baldwin rearrangement is a result of the non-reversibility of the tautomerisation of (418) under the conditions of this reaction, *vide supra*. In contrast the application of Barton's conditions to (127) may allow equilibration of the imine and vinyl formamide to take place thus generating the thermodynamic product.

At this stage it became apparent that the thioester (429) was unlikely to be a by-product of the rearrangement reaction of either (133) or (257). Further credence to this suggestion was obtained on mixing the reaction mixtures with an authentic sample of (429)

(obtained by the reaction of *p*-thiocresol with acetic anhydride) and monitoring by ^1H and ^{13}C n.m.r. A signal at 10.2 p.p.m. in the ^1H n.m.r of both (133) and (257) was thought to be more consistent with thioformamide (433) and this was indeed confirmed by mixing the reaction mixtures with an authentic sample of (433) (obtained by the reaction of *p*-thiocresol with acetic formic anhydride). Further mixing of other potential by-products confirmed that, along with (433), acetic anhydride was also being generated.

The major problem with the mechanism previously proposed for the formation of (258) and (259), from the valine derived thiooxime (257), was that it was thought necessary to invoke the presence of water in the system which could act as a proton source. On reflection it was argued that decomposition of either acetic formic anhydride or (433) could deliver a proton which, for the former, is a well known process.^{287a} If this was the case then carbon monoxide would be expected to be evolved. Thus, the gas above a sealed reaction of (257) and triphenylphosphine/acetic formic anhydride was sampled after twenty-four hours by gas I.R. The distinctive absorbance of carbon monoxide was indeed observed. To gain some insight into whether this was the result of the spontaneous decomposition of acetic formic anhydride to carbon monoxide and acetic acid or as a result of the presence of a particular species in the reaction mixture a number of control experiments were conducted. Acetic formic anhydride was stirred at room temperature for twenty-four hours with dichloromethane as solvent. No evolution of carbon monoxide was detected after this time thereby ruling out its spontaneous decomposition. Furthermore the evolution of carbon monoxide was not detected on stirring acetic formic anhydride with either triphenylphosphine or thiooxime (257). Thus, it would appear that the evolution of carbon monoxide is a facet of the rearrangement reaction.

5.4 Proposed mechanism

Based on the observations discussed in both Sections 5.2 and 5.3 above, the following mechanisms are now proposed, Scheme 117:

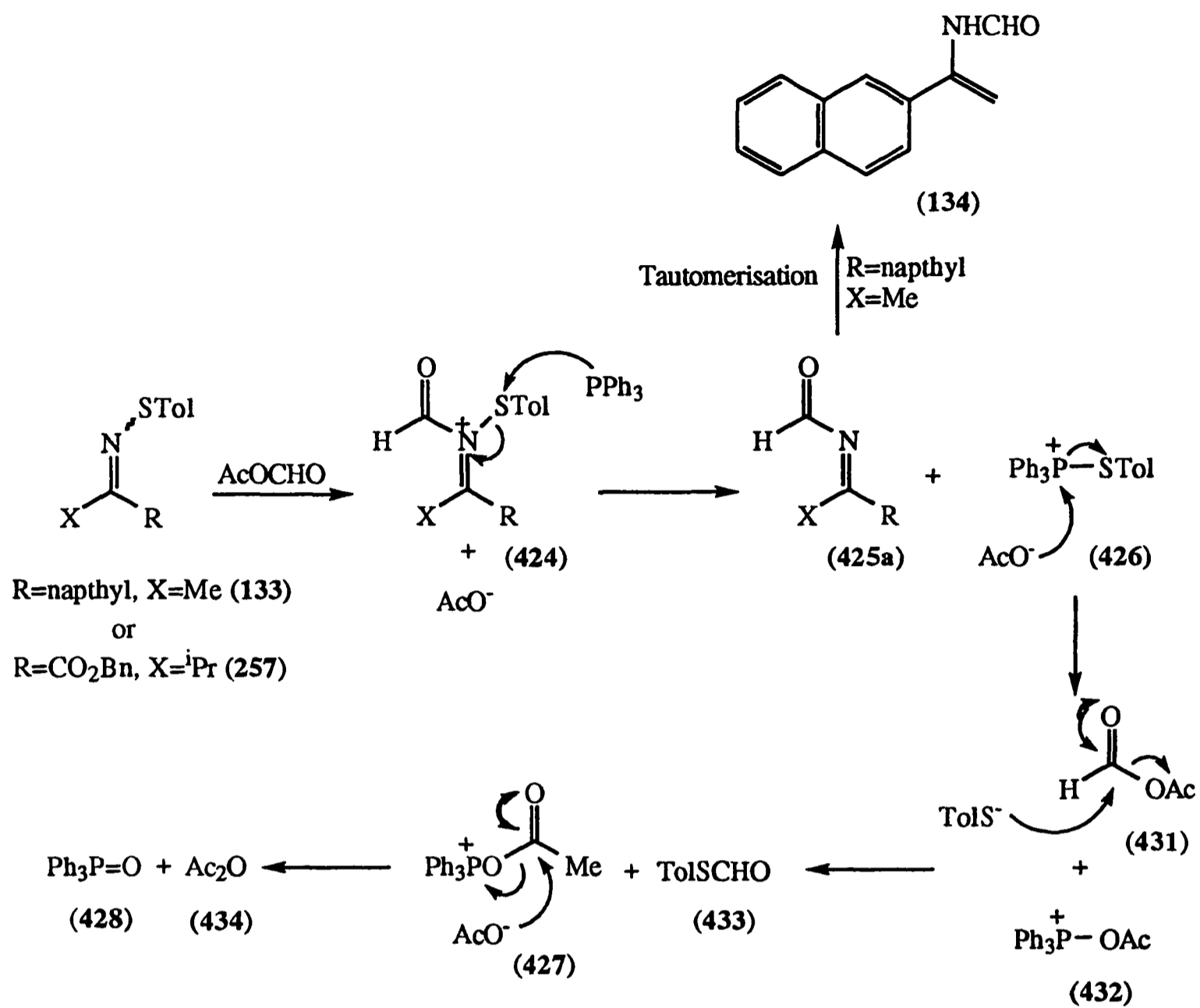

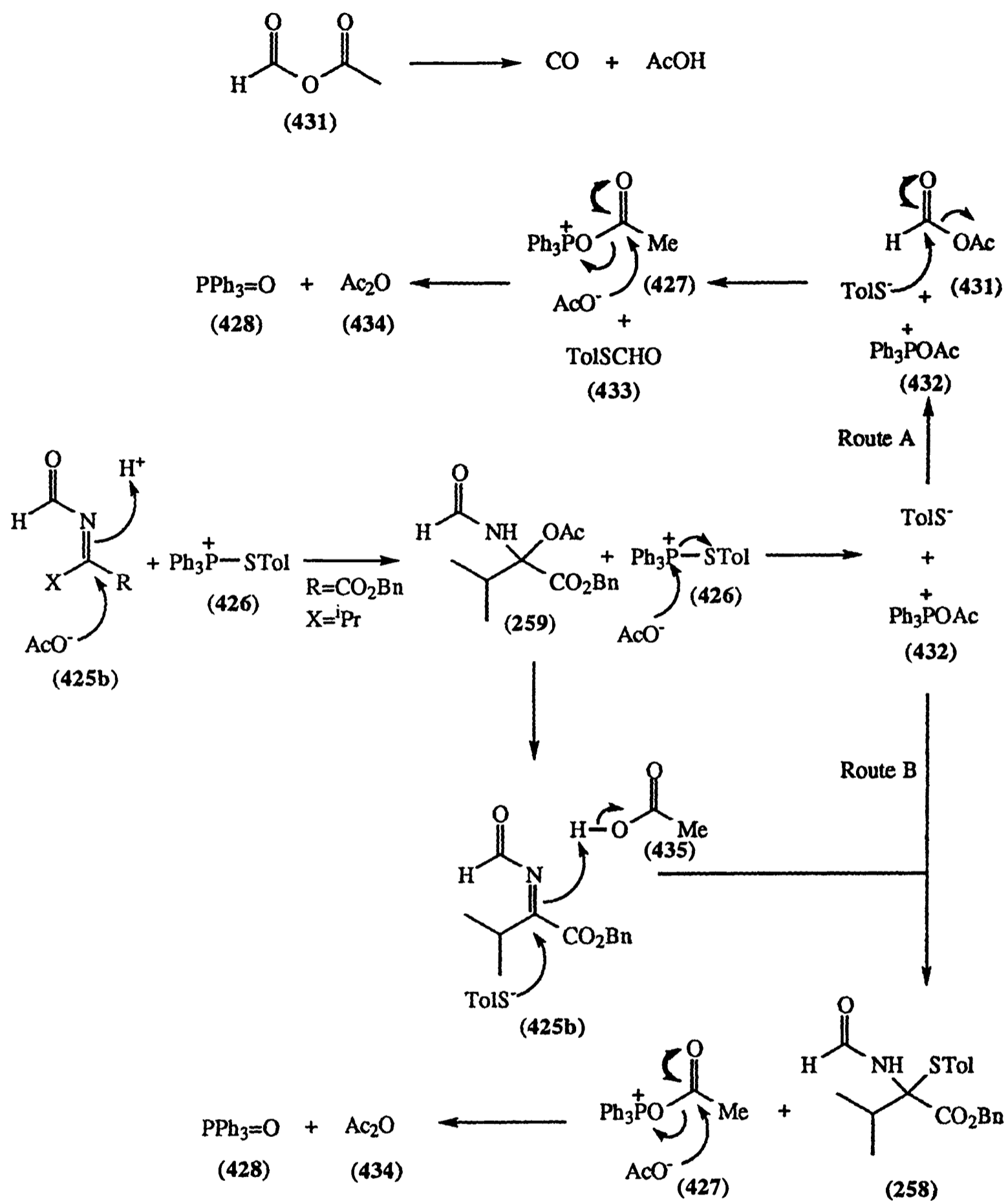

Scheme 117 cont.

Thus formylation and cleavage of the N-S bond occurs as discussed previously to generate an *N*-formylimine which in the case of (133) tautomerises to the vinyl formamide (134). Generation of the reaction by-products can arise from phosphonium salt (426) as indicated. Displacement of the thiotolyl group occurs followed by the reaction of tolylsulphide with a second equivalent of acetic formic anhydride to generate (432) and acetate. Attack of

acetate. Attack of acetate on the acyloxyphosphonium salt then delivers acetic anhydride and triphenylphosphine oxide. Considering (257), attack of acetate or tolylsulphide on imine (425b) in the Michael sense can potentially generate the α -acetoxy (Route A) and α -thioformamide (Route B) respectively with acetic formic anhydride (or (433)) acting as the proton source. A number of alternative mechanisms may be proposed for the method by which acetic formic anhydride or (433) may act to deliver a proton. One, which is in agreement with previous studies involving acetic formic anhydride is shown in Scheme 118 and involves the formation of the diformylated species which would break down^{287b} to (258) and (259). Unfortunately time constraints have prevented a more in depth study of this reaction mechanism.

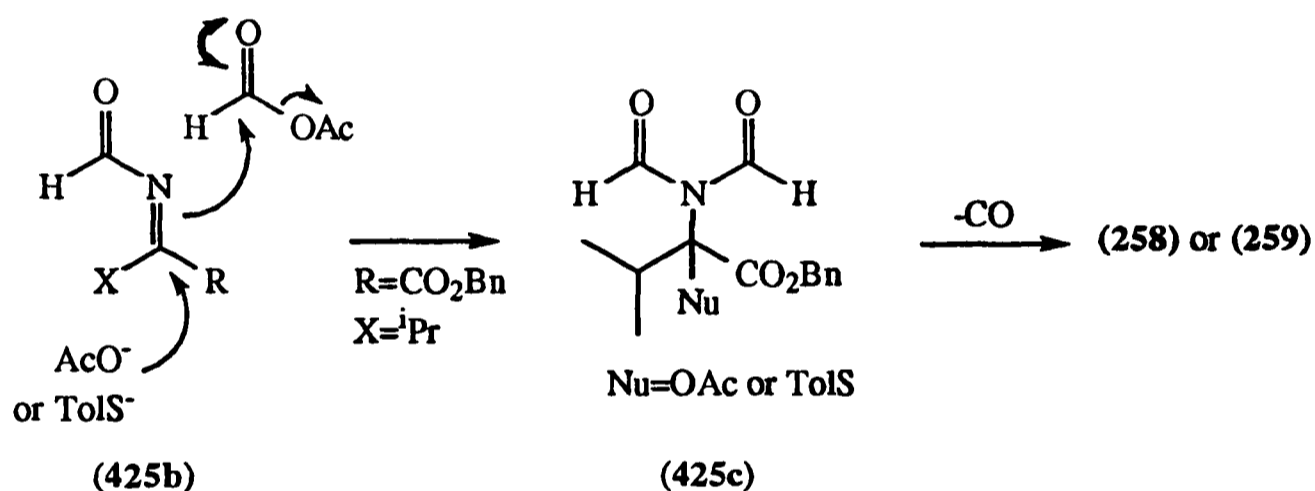

Scheme 118

5.6 Conclusion

It remains to consider the origin of the differing behaviour of the variously substituted thiooximes. For the valine derived thiooxime (257) it had been proposed that steric effects (such as A_{1,2} or allylic strain)²⁸⁸ in the vinyl formamide and its preceding transition state were preventing tautomerisation of imine (425b). A Newman projection indicating the origin of such strain is shown in Figure 21. However, the observation that the alanine derived thiooxime (435) which does not have any β -substituents also rearranged to the corresponding α -thioformamide, Scheme 119, led to the conclusion that tautomerisation in these ester systems is not significantly disfavoured by steric interactions.²¹⁶

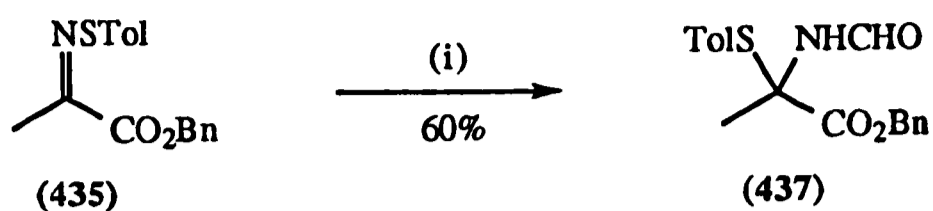

(i) PPh_3 (3eq.), AcOCHO (3eq.), propylene oxide, DCM, 24h., RT.

Scheme 119

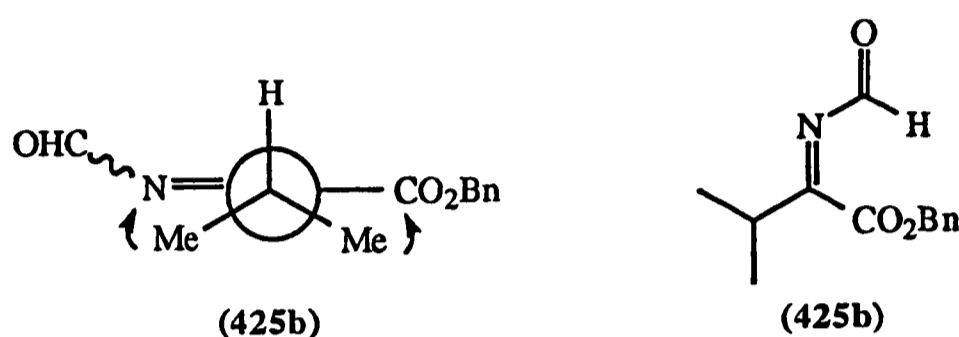
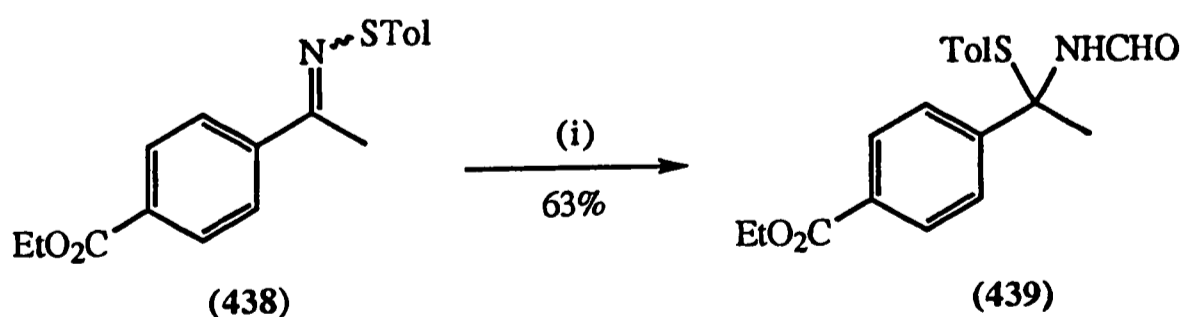

Figure 21

A plausible alternative is that addition to imine (425b) by nucleophiles in the Michael sense is favoured by the electron withdrawing nature of the ester functionality. Further weight is added to this explanation by the recent observation that the thiooxime (438), which can formally be thought of as a doubly vinylogous ester system, also generates the α -thioformamide (439), Scheme 120. Comparison of the hydration constants (K_d for the hydrate) of acetone (500) and methyl pyruvate (0.32) indicate by analogy the greater potential for the imine from (257) to become sp^3 hybridised.



(i) PPh_3 (3eq.), AcOCHO (3eq.), propylene oxide, DCM, 24h., RT.

Scheme 120

The cyclopentyl thiooxime (324) shows transitional behavior between (133) and (257) under the rearrangement conditions with generally a mixture of vinyl formamide (319)

The cyclopentyl thiooxime (324) shows transitional behavior between (133) and (257) under the rearrangement conditions with generally a mixture of vinyl formamide (319) and α -acetoxy formamide (340) being generated with this substrate. The introduction of a double bond into the five membered ring would result in strain which may slow tautomerisation of the imine intermediate in comparison to the more simple thiooximes such as (133) and allow trapping by acetate to compete. The presence of electron withdrawing groups on the five membered ring may also enhance the ability of the *N*-formylimine to react with acetate and generate an sp^3 rather than an sp^2 hybridised centre. The recent observation that the amino acid anticapsin (450) which possesses an epoxy-keto moiety exists, in aqueous conditions, to a significant extent as the ketone hydrate (451) lends further credence to this suggestion, Scheme 121.²⁸⁹

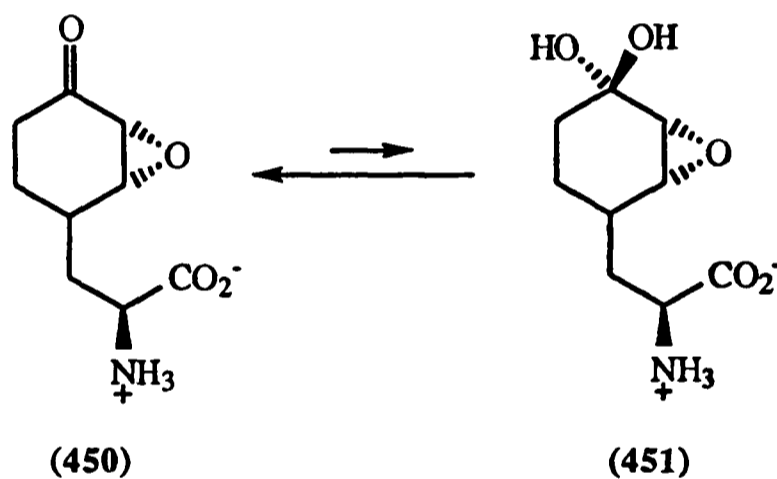

Scheme 121

Chapter 6

Experimental for Part I

6.1 General Experimental Techniques for Part 1 and Part II

Melting points (m.p.) were obtained using a Büchi 510 capillary melting point apparatus and are uncorrected.

Optical rotations were measured with a Perkin-Elmer 241 polarimeter at 20°C with a pathlength of 1dm. Concentrations (*c*) are given in g/100ml.

Elemental microanalyses were performed by Mrs. V. Lamburn, Dyson Perrins Laboratory, University of Oxford.

Fourier transform Infrared (FT IR) spectra were recorded as thin films, KBr discs or in CDCl₃ solution on a Perkin-Elmer 1750 Fourier Transform spectrometer with major features of each spectra recorded. Absorptions are reported in wavenumbers (cm⁻¹). The following abbreviations are used: m, medium; s, strong and br, broad.

Proton nuclear magnetic resonance spectra (¹H n.m.r.) were recorded at 200MHz and 500MHz on Varian Gemini 200 or Bruker AC200 and Bruker AM500 or Bruker AMX500 spectrometers respectively. For ¹H n.m.r. recorded in deuterated solvents chemical shifts (δ_{H}) are quoted in parts per million (p.p.m.) and are referenced to the residual solvent peak. The following abbreviations were used: s, singlet, d, doublet, t, triplet, q, quartet, sp, septet, m, multiplet and br, broad. Coupling constants (*J*) were recorded in Hertz to the nearest 0.5Hz.

Carbon magnetic resonance spectra (¹³C n.m.r.) spectra were recorded at 50.31MHz and 125.77MHz on Varian Gemini 200 or Bruker AC200 and Bruker AM500 or AMX500 spectrometers respectively using DEPT editing. Quaternary carbons are assigned from a broad band decoupled analysis used in conjunction with the DEPT program. Chemical shifts

(δ C) are quoted in p.p.m. and referenced to CDCl_3 unless otherwise stated. Spectra recorded in D_2O are referenced to internal 1,4-dioxane.

Fluorine magnetic resonance spectra (^{19}F n.m.r.) spectra were recorded at 235.19MHz on a Bruker AM250 spectrometer. Chemical shifts are quoted in p.p.m. and referenced to CFCl_3 .

Low resolution mass spectra (m/z) were recorded on a V.G Micromass ZAB 1F (FAB/CI/DCI), V.G.Masslab 20-250 (CI/DCI/EI), a V.G. TRIO 1 (GCMS) or a V.G. BIO-Q (Electrospray) spectrometer, with only molecular ions (M^+), fragments from molecular ions and major peaks being reported.

High resolution mass spectra (high resolution m/z) were recorded by the EPSRC mass spectrometry service centre at the University of Wales, Swansea.

Flash chromatography was accomplished on silica gel using SorbsilTM C60 (mpd 60Å) silica gel (30-60 μm) or Janssen (0.035-0.070mm) silica gel by the method of Still *et al.*²⁹⁰ Thin layer chromatography was performed on glass plates pre-coated with Merck silica gel 60 F₂₅₄ which were visualised by the quenching of u.v. fluorescence ($\lambda_{\text{max}}=254\text{nm}$), by staining with iodine, 10%w/v ammonium molybdate in 2M sulfuric acid, anisaldehyde or ninhydrin, all followed by heat.

High pressure liquid chromatography (HPLC) was performed on a twin Waters Delta Prep 4000 preparative chromatography system using a Waters model 7125 analytical injector, a Waters model 490E absorbance detector, a Servogor 464 vertical recorder and a column packed with Zorbax Hypersil ODS.

Dowex 50W-X8(H) ion exchange resin was washed prior to each use with 1M hydrochloric acid then water (to pH7) followed by 1M ammonium hydroxide then water (to pH7).

All solvents were distilled before use. Anhydrous dichloromethane, P.E. 30-40, P.E. 40-60, pyridine, triethylamine, methanol, benzene and acetonitrile were obtained by distillation from calcium hydride under an inert atmosphere of argon. Anhydrous THF and anhydrous diethyl ether were obtained by distillation from sodium/benzophenone ketyl under nitrogen and anhydrous DMF by distillation from calcium hydride under reduced pressure.

P.E. 30-40 refers to the the fraction of light petroleum ether boiling between 30-40°C. P.E. 40-60 refers to the the fraction of light petroleum ether boiling between 40-60°C. Solvents were evaporated at 40°C or below on a Büchi R110 Rotavapor; high boiling solvents were evaporated on a Büchi R110 Rotavapor fitted with a dry ice condenser at <2mmHg. Kugelrohr distillations were performed at the recorded temperature and pressure.

Triphenyltinhydride was prepared according to the method of Kuivila from triphenyltin chloride.²⁹¹ Commercial solutions of ⁿBuLi were titrated using diphenylacetic acid. Acetic formic anhydride²⁹² and *p*-tolylsulfenyl chloride²⁹³ was prepared according to the literature procedures, *N,N*-bis-(trimethyl)silyl-4-(methylphenyl)sulfenamide according to the method of Ikehira *et al.*²⁹⁴ and (*L*) and (*D*)-tyrosine ^tbutyl esters according to the method of Roeske.²⁹⁵ Diazomethane was prepared according to the method of Moore and Reed.²⁹⁶ *N*-(Benzyloxycarbonyl)hydroxylamine was prepared according to the method of Boyland.²⁴³ Tetraethylammonium periodate and 6% sodium amalgam were prepared according to the methods reported by Aldous.²¹⁴ Iodobenzene dichloride was prepared according to the method of Lucas and Kennedy.²⁷³

All other reagents were purified in accordance with the instructions in D.D. Perrin and W.L.F. Armarego, 'Purification of Laboratory Chemicals', Pergamon Press, London, Third edition, 1988 or used as obtained from commercial sources.

6.2 Experimental Procedures

6.2.1 Studies Towards the Synthesis of (249), a Biologically Active Analogue of Antibiotic A-32390A

(2*S*, 3*S*)-2,3-Di-[^tbutyldimethylsilyloxy]butane-1,4-diol (272)

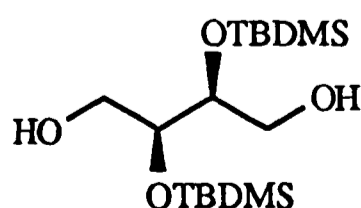

To a stirred solution of (2*R*, 3*R*)-diethyl 2,3-di-^tbutyldimethylsilyloxytartrate (270) (2.33g, 5.35mmol.) in anhydrous THF (10ml), under an inert atmosphere of argon, cooled to 0°C was added LiEt₃BH (32.1ml of a 1M solution in THF, 32.1mmol.). The reaction mixture was then stirred at room temperature for thirty minutes before being quenched at 0°C by the rapid dropwise addition of 1M HCl (20ml) as rapidly as the quench would allow. The mixture was concentrated *in vacuo*, diluted with ether (80ml), washed 1M HCl (20ml), dried (Na₂SO₄), filtered and concentrated *in vacuo* to yield a yellow oil. Flash chromatography (SiO₂, P.E. 30-40: ether; 70:30) afforded (2*S*, 3*S*)-2,3-di-^tbutyldimethylsilyloxybutane-1,4-diol (272) as a white solid (1.31g, 70%), (R_f 0.3, P.E. 30-40: ether; 70: 30); [α]_D -24.5 (*c* 1.0 in CHCl₃); (Found: C, 54.90; H, 11.14. C₁₆H₃₈O₄Si₂ requires C, 54.81; H, 10.92%); ν_{max} (FT IR, KBr disc) 3396br s (OH), 2958s, 2932s, 2895m, 2360m, 1475s, 1389m, 1255s, 1149s, 1039s, 1007s, 838s and 773m cm⁻¹; δ_H (200MHz; CDCl₃) 0.13 (12H, s, Si(CH₃)₂C(CH₃)₃), 0.92 (18H, s, Si(CH₃)₂C(CH₃)₃), 2.51 (2H, br s, OH) and 3.70-3.86 (6H, m, CH₂OH and CHCH₂OH); δ_C (50MHz; CDCl₃) -4.76 (Si(CH₃)₂C(CH₃)₃), 18.01 (Si(CH₃)₂C(CH₃)₃), 25.77 (Si(CH₃)₂C(CH₃)₃), 62.37 (CH₂OH) and 74.06 (CHCH₂OH); m/z (chemical ionisation, NH₃) 351[(MH)⁺, 100%], 219[11], 161[12], 131[11], 117[10], 90[14] and 73[20].

(2*S*, 3*S*)-2,3-Di-^tbutyldimethylsilyloxybutane-1,4-di-*N*-[benzyloxycarbonyl-(*L*)-valinate]
(283)

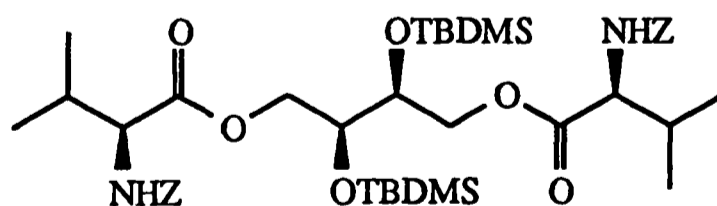

To a stirred solution of *N*-CBZ-(*L*)-valine (754mg, 3.00mmol.), (2*S*, 3*S*)-2,3-di-^tbutyldimethylsilyloxybutane-1,4-diol (272) (530mg, 1.50mmol.) and DMAP (37mg, 0.30mmol.) in anhydrous dichloromethane (10ml) under an inert atmosphere of argon, cooled to 0°C, was added dropwise over ten minutes. DCC (655mg, 3.20mmol.) was then

added as a solution in anhydrous dichloromethane (30ml). The reaction mixture was stirred at room temperature for twenty hours before being filtered and washed with 0.5M HCl (10ml), 1M Na₂CO₃ (10ml) and saturated aqueous brine (10ml). The organic phase was dried (MgSO₄), filtered and concentrated *in vacuo* to yield a yellow oil. Flash chromatography (SiO₂, P.E. 30-40: ether; 90:10; 70: 30; gradient elution) afforded (2*S*, 3*S*)-2,3-di-[*t*butyldimethylsilyloxy]butane-1,4-di-[*N*-benzyloxycarbonyl-(*L*)-valinate] (283) as a colourless oil (1.23g, quant.), (R_f 0.4, P.E. 30-40: ether; 70: 30); [α]_D -24.1 (c 1.0 in CHCl₃); (Found: C, 61.59; H, 8.55; N, 3.55. C₄₂H₆₈N₂O₁₀Si₂ requires C, 61.73; H, 8.39; N, 3.43%); ν_{max} (FT IR, CDCl₃ solution, NaCl plates) 3155m (NH), 2959m, 2932m, 1794m, 1723s (C=O), 1643s, 1512s, 1471s, 1383m and 1086s cm⁻¹; δ_H (200MHz; CDCl₃) 0.85 (12H, s, Si(CH₃)₂C(CH₃)₃), 0.88 (18H, s, Si(CH₃)₂C(CH₃)₃), 0.90 and 0.95 (12H, 2 x d, 2 x *J* 7Hz, CH(CH₃)₂), 2.20 (2H, sp, *J* 7Hz, CH(CH₃)₂), 3.83-3.95 (2H, m, HCCH₂OCO), 4.10 (2H, dd, *J* 6Hz, *J* 11.5Hz, 1 x HCCH₂OCO), 4.28-4.42 (4H, m, 1 x HCCH₂OCO and CHCH(CH₃)₂), 5.12 (4H, m, CH₂(C₆H₅)), 5.33 (2H, d, *J* 9Hz, NH) and 7.37 (10H, s, CH₂(C₆H₅)); δ_C (50MHz; CDCl₃) -4.89 and -4.59 (Si(CH₃)₂C(CH₃)₃), 17.58 and 18.90 (CH(CH₃)₂), 17.96 (Si(CH₃)₂C(CH₃)₃), 25.65 (Si(CH₃)₂C(CH₃)₃), 31.50 (CH(CH₃)₂), 59.29 (CHCH(CH₃)₂), 65.77 (HCCH₂OCO), 67.02 (CH₂(C₆H₅)), 76.74 (HCCH₂OCO), 128.05, 128.08 and 128.49 (aromatic CH), 136.52 (aromatic *ipso* C), 156.12 (NHCO₂) and 171.77 (CHCO₂); m/z (desorption chemical ionisation, NH₃) 833[(MNH₄)⁺, 23%], 816 [(MH)⁺, 23], 726[100], 709[45], 651[48], 618[30], 543[28], 458[24], 300[37], 162[50], 108[25] and 91[65].

(2*S*, 3*S*)-2,3-Di-[*t*butyldimethylsilyloxy]butane-1,4-di-(*L*)-valinate (284)

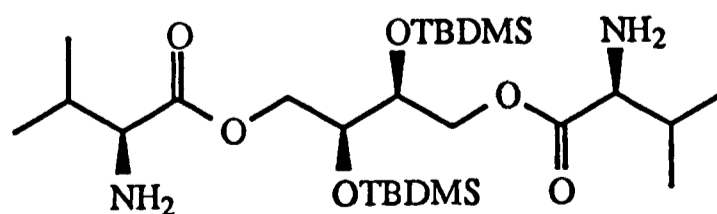

To a stirred solution of 10% Pd/C (50mg) in ethyl acetate (5ml), under an atmosphere of hydrogen, was added (2*S*, 3*S*)-2,3-di-[*t*butyldimethylsilyloxy]butane-1,4-di-[*N*-benzyloxycarbonyl-(*L*)-valinate] (283) (900mg, 1.10mmol.) as a solution in ethyl acetate (20ml). The reaction mixture was stirred for twenty four hours then filtered through Celite® and concentrated *in vacuo* to yield (2*S*, 3*S*)-2,3-di-[*t*butyldimethylsilyloxy]butane-1,4-di-(*L*)-valinate (284) as a colourless oil (600mg, quant); $[\alpha]_D -40.0$ (*c* 1.0 in CHCl₃); ν_{\max} (FT IR, liquid film, NaCl plates), 3391br m (NH), 2958s, 2931s, 2895s, 2859s, 1739s (C=O), 1472s, 1256s, 1160s, 1125s, 839s and 779s cm⁻¹; δ_H (200MHz; CDCl₃) 0.10 (12H, s, Si(CH₃)₂C(CH₃)₃), 0.89 (18H, s, Si(CH₃)₂C(CH₃)₃), 0.93 and 1.00 (12H, 2 x d, 2 x *J* 7Hz, CH(CH₃)₂), 2.05 (2H, d of sp, *J* 5Hz, *J* 7Hz, CH(CH₃)₂), 3.31 (2H, d, *J* 5Hz, CHCH(CH₃)₂), 3.85-3.94 (2H, m, HCCH₂OCO), 4.10 (2H, dd, *J* 6.5Hz, *J* 11Hz, 1 x HCCH₂OCO) and 4.35 (2H, dd, *J* 2Hz, *J* 11Hz, 1 x HCCH₂OCO); δ_C (50MHz; CDCl₃) -4.92 and -4.61 (Si(CH₃)₂C(CH₃)₃), 17.23 and 19.28 (CH(CH₃)₂), 17.93 (Si(CH₃)₂C(CH₃)₃), 25.61 Si(CH₃)₂C(CH₃)₃), 32.18 (CH(CH₃)₂), 60.05 (CHCH(CH₃)₂), 65.29 (HCCH₂OCO), 72.20 (HCCH₂OCO) and 175.51 (CHCO₂); *m/z* (chemical ionisation, NH₃) 549[(MH)⁺, 100%], 392[18] and 72[50].

(2*S*, 3*S*)-2,3-Di-[*t*butyldimethylsilyloxy]butane-1,4-di-[3-methyl-2-(4-methylphenyl)thioimino butanoate] (285)

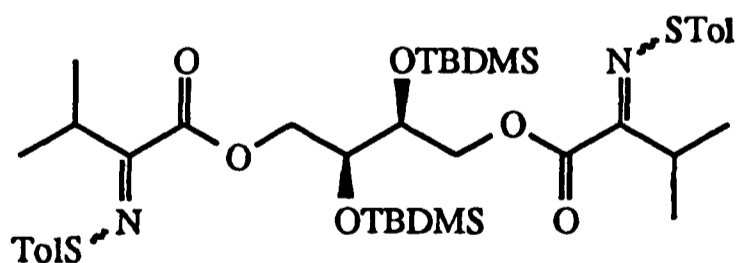

To a stirred solution of (2*S*, 3*S*)-2,3-di-[*t*butyldimethylsilyloxy]butane-1,4-di-(*L*)-valinate (284) (870mg, 1.58mmol.) in anhydrous dichloromethane (70ml), cooled to 0°C, under an inert atmosphere of argon, was added propylene oxide (11.1ml, 0.16mol.) and crushed 4Å molecular sieves (28g). The mixture was allowed to stand for two minutes then treated with *p*-tolylsulfenyl chloride (1.50g, 9.48mmol.). Stirring was continued for five

minutes at 0°C then at room temperature for three hours before saturated aqueous NaHCO₃ (20ml) was added. The two phase mixture was allowed to stir for two minutes then filtered and separated. The organic phase was washed with saturated aqueous NaHCO₃ (20ml), filtered and concentrated *in vacuo* to yield a yellow oil. Flash chromatography (SiO₂, P.E. 30-40: CH₂Cl₂; 50:50) afforded, as a mixture of geometric isomers, (2*S*, 3*S*)-2,3-di-[*t*butyldimethylsilyloxy]butane-1,4-di-[3-methyl-2-(4-methylphenyl)thioiminobutanoate] (285) as a yellow oil (1.08g, 87%), (R_f 0.3, P.E. 30-40: CH₂Cl₂; 30: 70); [α]_D -32.9 (c 1.0 in CHCl₃); (Found: C, 61.00; H, 8.45; N, 3.48. C₄₀H₆₄N₂O₆S₂Si₂ requires C, 60.87; H, 8.17; N, 3.55%); ν_{max} (FT IR, liquid film, NaCl plates) 2958s, 2930s, 2859m, 1718s (C=O), 1252s, 1179m, 1117m, 839, 807s and 778s cm⁻¹; δ_H (200MHz; CDCl₃) 0.08, 0.09 and 0.12 (12H, 3 x s, Si(CH₃)₂C(CH₃)₃), 0.88 and 0.90 (12H, 2 x s, Si(CH₃)₂C(CH₃)₃) 1.13-1.37 (12H, m, CH(CH₃)₂), 2.30, 2.34 and 2.37 (6H, 3 x s, (C₆H₄)CH₃), 3.08-3.32 (2H, m, CH(CH₃)₂), 4.02-4.11 (2H, m, HCCH₂OCO), 4.30-4.59 (4H, m, HCCH₂OCO) and 7.12-7.22 and 7.41-7.52 (2 x 4H, m, (C₆H₄)CH₃); δ_C (125MHz; CDCl₃) -4.78 and -4.64 (Si(CH₃)₂C(CH₃)₃), 17.78 (Si(CH₃)₂C(CH₃)₃), 17.97, 20.46, 20.61 and 21.02 (CH(CH₃)₂ and (C₆H₄)CH₃), 25.70 (Si(CH₃)₂C(CH₃)₃), 34.63 (CH(CH₃)₂), 64.80 (HCCH₂OCO), 71.60 (HCCH₂OCO), 124.97, 126.65 and 129.52 (aromatic CH), 136.35 and 138.16 (aromatic *ipso* C), 155.91 (NCCH(CH₃)₂) and 160.52 and 161.71 (CHCO₂); m/z (desorption chemical ionisation, NH₃) 789[(MH)⁺, 100%], 731[28], 667[28], 140[38] and 123[31].

(2*S*, 3*S*)-2,3-Di-[*t*butyldimethylsilyloxy]butane-1,4-di-[2-formamido-3-methyl-2-(4-methylphenyl) thiobutanoate] (288)

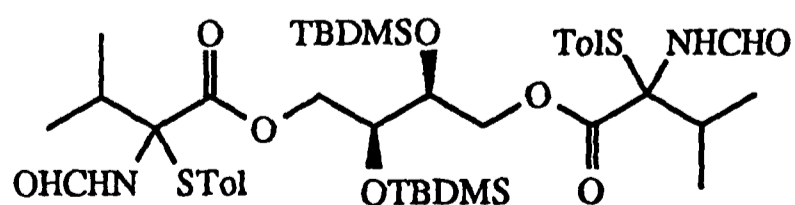

To a stirred solution of (2*S*, 3*S*)-2,3-di-[^tbutyldimethylsilyloxy]butane-1,4-di-[3-methyl-2-(4-methylphenyl)thioiminobutanoate] (285) (513mg, 0.65mmol.) in anhydrous dichloromethane (5ml) under an inert atmosphere of argon was added triphenylphosphine (1.02g, 3.90mmol.), propylene oxide (911μl, 13.00mmol.) and acetic formic anhydride (344mg, 3.90mmol.) as a solution in anhydrous dichloromethane (5ml). The reaction mixture was stirred at room temperature for sixty hours then diluted with dichloromethane (20ml), washed with saturated aqueous NaHCO₃ (3 x 15ml), dried (Na₂SO₄), filtered and concentrated *in vacuo* to afford a yellow solid. Flash chromatography (SiO₂, P.E. 30-40: ether; 40: 60; 25: 75; gradient elution) afforded (2*S*, 3*S*)-2,3-di-[^tbutyldimethylsilyloxy]butane-1,4-di-[2-formamido-3-methyl-2-(4-methylphenylthio)butanoate] (288) as a white crystalline solid (409mg, 74%) as a mixture of three diastereomers. An analytical sample was obtained by recrystallisation from P.E. 30-40, ether, m.p. 50-55°C, (R_f 0.3, P.E. 30-40: ether; 25: 75); [α]_D -37.8 (c 1.0 in CHCl₃); (Found: C, 59.24; H, 8.05; N, 3.30. C₄₂H₆₈N₂O₈S₂Si₂ requires C, 59.40; H, 8.07; N, 3.30%); ν_{max} (FT IR, KBr disc) 3371br m, 2957m, 2930m, 1736s (ester C=O), 1694s (amide C=O), 1255s, 1120m and 839s cm⁻¹; δ_H (200MHz; CDCl₃) 0.15, 0.16, 0.18, 0.19 and 0.22 (12H, 5 x s, Si(CH₃)₂C(CH₃)₃), 0.86, 0.88, 0.89, 0.91, 0.92, 0.93, 0.94, 0.95 and 0.97 (18H, 9 x s, Si(CH₃)₂C(CH₃)₃), 1.12-1.35 (12H, m, CH(CH₃)₂), 2.25, 2.27, 2.28, 2.31 and 2.34 (6H, 5 x s, (C₆H₄)CH₃), 2.54-2.70 and 3.20-3.40 (2H, 2 x m, CH(CH₃)₂), 3.98-4.14 (2H, m, HCCH₂OCO), 4.22-4.63 (4H, m, HCCH₂OCO), 6.40-6.59 (2H, m, NHCHO) and 6.98-7.20 and 7.22-7.30 (2 x 4H, 2 x m, (C₆H₄)CH₃) and 8.02-8.14 and 8.68-8.81 (2H, 2 x m, NHCHO); δ_C (125MHz; CDCl₃) -4.73, -4.53 and -4.46 (Si(CH₃)₂C(CH₃)₃), 16.85 and 16.99 (Si(CH₃)₂C(CH₃)₃), 17.94, 18.41 and 22.21 ((C₆H₄)CH₃ and CH(CH₃)₂), 25.70 (Si(CH₃)₂C(CH₃)₃), 33.51, 36.75, 36.86 and 37.12 (CH(CH₃)₂), 66.86, 67.75, 68.28 (HCCH₂OCO), 71.85, 71.87, 72.00 and 72.17 (HCCH₂OCO), 74.49, 74.64, 75.50 and 76.75 (CCH(CH₃)₂) 129.49, 125.83, 129.80, 129.92, 130.17, 130.23, 135.63, 135.98, 136.06, 136.83 and 137.04 (aromatic CH), 140.31 and 140.55 (aromatic *ipso* C), 158.71 and 164.73 (NHCHO) and 170.19 (CHCO₂); m/z (fast atom bombardment) 871[(MNa)⁺, 10%], 573[10], 205[11], 177[14], 147[10], 115[11], 73[100] and 59[24].

(2*S*, 3*S*)-2,3-Di-[*t*butyldimethylsilyloxy]butane-1,4-di-[2-formamido-3-methyl-but-2-enoate]
(287)

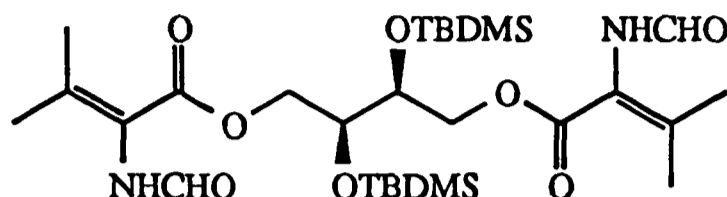

Method 1

To a stirred solution of (2*S*, 3*S*)-2,3-di-[*t*butyldimethylsilyloxy]butane-1,4-di-[2-formamido-3-methyl-2-(4-methylphenylthio)butanoate] (288) (200mg, 0.24mmol.) in anhydrous dichloromethane (8ml) was added DBU (176μl, 1.18mmol.). The reaction mixture was stirred at room temperature for twenty four hours then diluted with dichloromethane (40ml) and washed with 1M HCl (10ml). The organic phase was separated, dried (Na₂SO₄) and concentrated *in vacuo* to yield a yellow oil. Flash chromatography (SiO₂, ethyl acetate: ether; 30: 70) afforded (2*S*, 3*S*)-2,3-di-[*t*butyldimethylsilyloxy]butane-1,4-di-[2-formamido-3-methyl-but-2-enoate] (287) as a white crystalline solid (106mg, 75%), m.p. 160-162°C (P.E. 30-40: Et₂O), (R_f 0.3, ether: ethyl acetate; 70: 30); [α]_D -27.0 (*c* 1.0 in CHCl₃); (Found: C, 55.97; H, 8.84; N, 4.53. C₂₈H₅₂N₂O₈Si₂ requires C, 55.97; H, 8.72; N, 4.66%); ν_{max} (FT IR, KBr disc) 2957m, 2931m, 1723s and 1680s (α,β-unsaturated ester), 1664 (amide C=O), 1504m, 1387m, 1342m, 1299m, 1238m, 1209m, 1133s, 1115m, 1092m, 839m and 783m cm⁻¹; δ_H (200MHz; CDCl₃) 0.05, 0.07 and 0.11 (12H, 3 x s, Si(CH₃)₂C(CH₃)₃), 0.89 (18H, s, Si(CH₃)₂C(CH₃)₃), 1.90, 2.21 and 2.00, 2.26 and 2.10 and 2.29 (12H, 3 x pair of singlets, C(CH₃)₂, three isomers), 3.81-3.95 (2H, m, HCCH₂OCO), 4.12-4.31 (4H, m, HCCH₂OCO), 7.81-7.20 (2H, m, NHCHO), 7.91-7.99 and 8.18-8.26 (2H, 2 x m, NHCHO); δ_C (125MHz; CDCl₃) -5.23, -4.80 and -4.72 (Si(CH₃)₂C(CH₃)₃), 17.79 and 17.98 (Si(CH₃)₂C(CH₃)₃), 21.23 and 22.69, 21.54 and 22.75, 21.54 and 22.95 (CH(CH₃)₂), 25.52 (Si(CH₃)₂C(CH₃)₃), 63.82, 64.10 and 65.23 (HCCH₂OCO), 69.89, 70.53 and 70.80 (HCCH₂OCO), 119.75, 120.89 and 120.99 (C(CH₃)₃), 147.63, 147.77 and 149.35 (C(CH₃)₂), 160.23, 165.43 and 165.98

(NHCHO) and 164.31 (CO₂); m/z (desorption chemical ionisation, NH₃) 618[(MNH₄)⁺, 12%], 601[(MH)⁺, 100], 573[12], 543[22], 200[30] and 126[66].

Method 2

To a stirred solution of (2*S*, 3*S*)-2,3-di-[*t*-butyldimethylsilyloxy]butane-1,4-di-[3-methyl-2-(4-methylphenyl)thioiminobutanoate] (285) (100mg, 0.13mmol.) in anhydrous dichloromethane (1ml) under an inert atmosphere of argon was added polymer supported triphenylphosphine (85mg of a 3mmol/g solid, 0.25mmol.) and acetic formic anhydride (17mg, 0.25mmol.) as a solution in anhydrous dichloromethane (2ml). The reaction mixture was stirred at room temperature for twelve hours afterwhich t.l.c. analysis indicated a mixture of α -thioformamide and α -acetoxyformamide. The mixture was filtered and concentrated *in vacuo*. The residue was then diluted with anhydrous dichloromethane (2ml) and stirred under an inert atmosphere of argon. Mercuric acetate (81mg, 0.25mmol.) was added and the mixture was stirred for five minutes whereupon t.l.c. analysis indicated that no α -thioformamide remained. DBU (95 μ l, 0.63mmol.) was added and the mixture stirred for a further fifteen minutes before being diluted with dichloromethane (40ml) and washed with saturated aqueous NaHCO₃ (10ml), dried (Na₂SO₄), filtered and concentrated *in vacuo* to afford a white solid. Flash chromatography (SiO₂, ethyl acetate: ether; 30: 70) afforded (2*S*, 3*S*)-2,3-di-[*t*-butyldimethylsilyloxy]butane-1,4-di-[2-formamido-3-methyl-but-2-enoate] (287) as a white crystalline solid (47mg, 62%). Spectroscopic data were identical to those obtained for the analytical sample prepared by method 1 above.

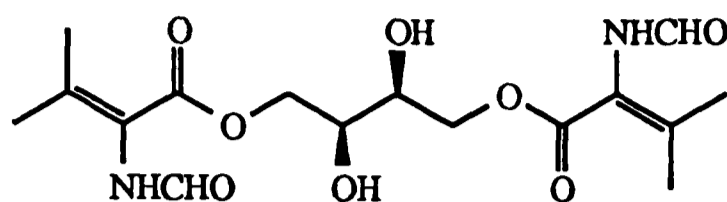
(2*S*, 3*S*)-1,4-Di-[2-formamido-3-methyl-but-2-enoate]-2,3-di-hydroxybutane (296)

A solution of (2*S*, 3*S*)-2,3-di-[*t*butyldimethylsilyloxy]butane-1,4-di-[2-formamido-3-methyl-but-2-enoate] (**287**) (50mg, 0.08mmol.) in 90% formic acid (2ml) was stirred at room temperature for four hours. The mixture was concentrated *in vacuo* to half the initial volume and then diluted with H₂O to the original volume. This procedure was repeated three times and the mixture was then concentrated *in vacuo* to afford (2*S*, 3*S*)-1,4-di-[2-formamido-3-methyl-but-2-enoate]-2,3-di-hydroxybutane (**296**) as a white crystalline solid (31mg, quant.). An analytical sample was obtained by recrystallisation from acetone, m.p. 129-131°C (lit.²¹⁰ 125-128°C); [α]_D -17.6 (*c* 0.13 in acetone); (Found: C, 51.51; H, 6.77; N, 7.47. C₁₆H₂₄N₂O₈ requires C, 51.61; H, 6.50; N, 7.52%); ν_{\max} (FT IR, KBr disc) 3282br, s (NH), 1720s and 1656s (α,β -unsaturated ester), 1641s (amide C=O), 1511s, 1387m, 1238m, 1212m, 1087m and 1055m cm⁻¹; δ_{H} (200MHz; CDCl₃) 1.74 and 1.96 (12H, 2 x s, C(CH₃)₂, major isomer) and 1.84 and 2.08 (9H, 2 x s, C(CH₃)₂, minor isomer), 3.60-3.82 (2H, m, 2 x HCCH₂OCO), 3.95-4.12 (4H, m, 2 x HCCH₂OCO), 4.84 (2H, d, *J* 5.5Hz, CHOH), 7.85 (2H, d, *J* 12Hz, NHCHO, minor isomer) and 8.00 (2H, s, NHCHO, major isomer), 8.87 (2H, d, *J* 12Hz, NHCHO, minor isomer) and 9.38 (2H, s, NHCHO, major isomer); δ_{C} (125MHz; CDCl₃) 20.53 and 21.48 (C(CH₃)₂, major isomer), 21.27 and 22.30 (C(CH₃)₂, minor isomer), 65.26 (HCCH₂OCO, major isomer), 65.81 (HCCH₂OCO, minor isomer), 68.54 (HCCH₂OCO), 121.29 (C(CH₃)₂, major isomer), 121.79 (C(CH₃)₂, minor isomer), 140.47 (C(CH₃)₂), 159.88 (NHCHO, major isomer), 164.20 (CO₂) and 164.94 (NHCHO, minor isomer); *m/z* (fast atom bombardment) 395 [(MNa)⁺, 4%], 373[20], 355[10], 230[25], 152[29], 135[45], 126[100], 103[29], 98[17], 85[70], 79[22], 70[17] and 57[10].

(2*S*, 3*S*)-1,4-Di-[2-isocyano-3-methyl-but-2-enoate]-2,3-di-[trimethylsilylethoxymethoxy]butane (279)

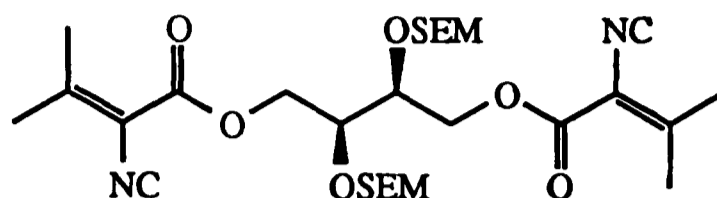

To a stirred solution of (2*S*, 3*S*)-1,4-di-[2-formamido-3-methyl-but-2-enoate]-2,3-di-[trimethylsilylethoxymethoxy]butane (278) (25mg, 0.04mmol.) in anhydrous pyridine (1ml) under an inert atmosphere of argon was added (carboxysulfamoyl)triethylammonium hydroxide inner salt (Burgess reagent) (35mg, 0.14mmol.). The mixture was stirred for twenty hours whereupon t.l.c. analysis indicated that starting material remained. Burgess reagent (35mg, 0.14mmol.) was added and the mixture stirred for a further ten hours. The mixture was then concentrated *in vacuo* to yield a yellow oil. Flash chromatography (SiO₂, P.E. 30-40: ether; 75: 25) afforded (2*S*, 3*S*)-1,4-di-[2-isocyano-3-methyl-but-2-enoate]-2,3-di-[trimethylsilylethoxymethoxy]butane (279) as a yellow oil (14mg, 56%). ¹H n.m.r., t.l.c. and I.R. were identical to those previously reported for (279).²¹⁶

(2*S*, 3*S*)-1,4-Di-[2-formamido-3-methyl-but-2-enoate]-2,3-di-[trimethylsilyloxy]butane (308)

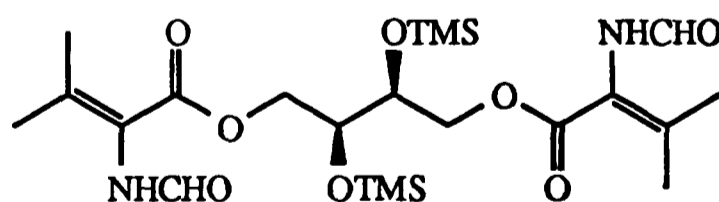

To a stirred solution of (2*S*, 3*S*)-1,4-di-[2-formamido-3-methyl-but-2-enoate]-2,3-di-hydroxybutane (296) (50mg, 0.13mmol.) in anhydrous DMF (two drops), under a stream of argon was added trimethylsilyl cyanide (1ml) and the mixture was stirred at room temperature for five minutes. Argon was then bubbled through the mixture until all the excess trimethylsilyl cyanide, HCN and DMF had evaporated to afford (2*S*, 3*S*)-1,4-di-[2-

formamido-3-methyl-but-2-enoate]-2,3-di-[trimethylsilyloxy]butane (308) as a white crystalline solid (69mg, quant.); ν_{\max} (FT IR, KBr disc) 2952m, 1721s and 1681s (α,β -unsaturated ester), 1654s (amide C=O), 1506s, 1388m, 1302m, 1255m, 1239m, 1217m, 1128m, 1094m and 846s cm^{-1} ; δ_{H} (200MHz; CDCl_3) 0.14 (18H, s, $\text{Si}(\text{CH}_3)_3$), 1.88, 2.20 and 1.99, 2.25 and 2.00 and 2.27 (12H, 3 x pair of singlets, $\text{C}(\text{CH}_3)_2$, 3 isomers), 3.80-3.91 (2H, m, 2 x HCCH_2OCO), 4.04-4.48 (4H, m, 2 x HCCH_2OCO), 7.36 (2H, br s, NHCHO), 7.94 (2H, d, J 12Hz, NHCHO , major isomer) and 8.12-8.23 (2H, m, NHCHO , minor isomer); m/z (chemical ionisation, NH_3), 517[(MH)⁺, 40%], 473[20], 374[19], 267[18], 258[20], 216[20], 206[22], 126[100], 100[20], 90[58] and 73[21].

(2*S*, 3*S*)-1,4-Di-[2-isocyano-3-methyl-but-2-enoate]-2,3-di-[trimethylsilyloxy]butane (309)

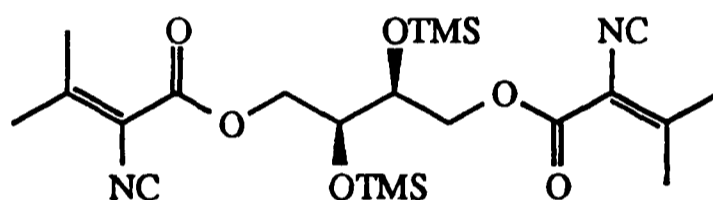

To a stirred solution of (2*S*, 3*S*)-1,4-di-[2-formamido-3-methyl-but-2-enoate]-2,3-di-[trimethylsilyloxy]butane (308) (35mg, 0.07mmol.) in anhydrous dichloromethane (3ml), cooled to -78°C , under an inert atmosphere of argon was added *N,N*-diisopropylethylamine (142 μl , 0.81mmol.) and trifluoromethanesulfonic anhydride (34 μl , 0.20mmol.). The reaction mixture was stirred for twenty minutes at -78°C then 5% aqueous NaHCO_3 (7ml) was added. The two phase mixture was allowed to warm to room temperature, separated and the organic phase was then washed with 5% aqueous NaHCO_3 (7ml), dried (Na_2SO_4), filtered and concentrated *in vacuo* to afford a yellow oil. Flash chromatography (SiO_2 , P.E. 30-40: ether; 75:25) afforded (2*S*, 3*S*)-2,3-di-[trimethylsilyloxy]butane-1,4-di-[2-isocyano-3-methyl-but-2-enoate] (309) as a yellow oil (27mg, 80%), (R_f 0.2, P.E. 30-40: ether; 85:15); $[\alpha]_{\text{D}} -22.8$ (c 0.5 in CHCl_3); (Found: C, 55.21; H, 7.43; N, 5.79. $\text{C}_{22}\text{H}_{36}\text{N}_2\text{O}_6\text{Si}_2$ requires C, 54.99; H, 7.55; N, 5.83%); ν_{\max} (FT IR, KBr disc) 2960m, 2119s (NC), 1732s and 1654s (α,β -unsaturated ester), 1647m, 1625m, 1286s, 1254s, 1237s, 1220s, 1158s, 1134s, 1087s, 1041s, 1013s, 872s and 844s cm^{-1} ; δ_{H} (200 MHz; CDCl_3) 0.17

(18H, s, Si(CH₃)₃), 2.17 and 2.32 (12H, 2 x s, C(CH₃)₂), 3.97-4.08 (2H, m, HCCH₂OCO), 4.22 (2H, dd, *J* 4Hz, *J* 11Hz, 2 x HCCH₂OCO) and 4.32 (2H, dd, *J* 6Hz, *J* 11Hz, 2 x HCCH₂OCO); δ_C (125MHz; CDCl₃) 0.19 (Si(CH₃)₃), 21.04 and 24.61 (C(CH₃)₂), 66.05 (HCCH₂OCO), 71.36 (HCCH₂OCO), 115.23 (CC(CH₃)₂), 156.31 and 160.65 (NC and C(CH₃)₂) and 168.24 (CO₂); *m/z* (chemical ionisation, NH₃) 498[(MNH₄)⁺, 35%], 481[(MH)⁺, 92], 356[30], 240[32] and 90[100].

(2*S*, 3*S*)-2,3-Di-[hydroxybutane]-1,4-di-[2-isocyano-3-methyl-but-2-enoate] (249)

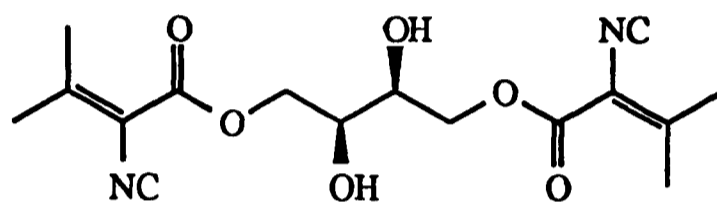

A solution of (2*S*, 3*S*)-1,4-di-[2-isocyano-3-methyl-but-2-enoate]-2,3-di-[trimethylsilyloxy]butane (309) (20mg, 0.04mmol.) in methanolic citric acid (1ml of a 1M solution) was stirred at room temperature for fifteen minutes then diluted with dichloromethane (20ml) and washed with saturated aqueous NaHCO₃ (5ml). The organic layer was separated, dried (Na₂SO₄), filtered and concentrated *in vacuo* to yield a yellow oil. Flash chromatography (SiO₂, P.E. 30-40: ethyl acetate; 80: 20, 60: 40 gradient elution) afforded (2*S*, 3*S*)-2,3-di-[hydroxybutane]-1,4-di-[2-isocyano-3-methyl-but-2-enoate] (249) as a white crystalline solid (13mg, 90%), m.p. 60-62°C (lit.²¹⁰ 63°C); (R_f 0.3, P.E. 30-40: ethyl acetate; 60: 40); [α]_D -3.2 (c 1.0 in CHCl₃) (lit.²¹⁰ -3.4 c 1.0 in CHCl₃); ν_{max} (FT IR, KBr disc) 3420br s (OH), 2121s (NC), 1732s and 1636s (α,β-unsaturated ester), 1287s, 1235s and 1096s cm⁻¹; δ_H (200MHz; CDCl₃) 2.17 and 2.32 (12H, 2 x s, C(CH₃)₂), 2.65 (2H, d, *J* 5.5Hz, OH), 3.98-4.10 (2H, m, 2 x HCCH₂OCO) and 4.38 (4H, d, *J* 5.5Hz, 2 x HCCH₂OCO); δ_C (125MHz; CDCl₃) 21.12 and 24.73 (C(CH₃)₂), 66.41 (HCCH₂OCO), 69.31 (HCCH₂OCO), 114.89 (CC(CH₃)₃), 157.41 and 160.70 (NC and C(CH₃)₃), 168.02 (CO₂); *m/z* (chemical ionisation, NH₃) 354[(MNH₄)⁺, 35%], 337[(MH)⁺, 100], 212[28] and 126[73].

(2*S*, 3*S*)-2,3-Di-[^tbutyldimethylsilyloxy]butane-1,4-di-[2-isocyano-3-methyl-but-2-enoate]
(289)

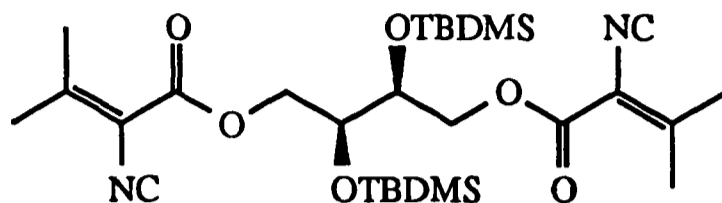

To a stirred solution of (2*S*, 3*S*)-2,3-di-[^tbutyldimethylsilyloxy]butane-1,4-di-[2-formamido-3-methyl-but-2-enoate] (287) (21mg, 0.035mmol.) in anhydrous dichloromethane (2ml), cooled to -78°C, under an inert atmosphere of argon was added *N,N*-diisopropylethylamine (75µl, 0.43mmol.) and trifluoromethanesulfonic anhydride (17µl, 0.10mmol.). The reaction mixture was stirred for twenty minutes at -78°C then 5% aqueous NaHCO₃ (2ml) was added. The two phase mixture was allowed to warm to room temperature, separated and the organic phase was then washed with 5% aqueous NaHCO₃ (2ml), dried (Na₂SO₄), filtered and concentrated *in vacuo* to afford a yellow oil. Flash chromatography (SiO₂, P.E. 30-40: ether; 75:25) afforded (2*S*, 3*S*)-2,3-di-[^tbutyldimethylsilyloxy]butane-1,4-di-[2-isocyano-3-methyl-but-2-enoate] (289) as a colourless oil (16mg, 82%), (R_f 0.3, P.E.30-40: ether; 75: 25), m/z (high resolution) Found 565.313, C₂₈H₄₈N₂O₆Si₂+H⁺ requires 565.313; [α]_D -17.5 (c 0.5 in CHCl₃); ν_{max} (FT IR, CDCl₃ solution, NaCl plates) 2957m, 2931m, 2125s (NC), 1729s and 1626s (α,β-unsaturated ester), 1286s, 1256s, 1230m, 1125s, 1099s, 927s and 811m cm⁻¹; δ_H (200 MHz; CDCl₃) 0.12 and 0.13 (12H, 2 x s, Si(CH₃)₂), 0.90 (18H, s, SiC(CH₃)₃), 2.17 and 2.32 (12H, 2 x s, C(CH₃)₂), 3.98-4.08 (2H, m, HCCH₂OCO), 4.25 (2H, dd, *J* 3.5Hz, *J* 11Hz, 2 x HCCH₂OCO), (2H, dd, *J* 6.5Hz, *J* 11Hz, 2 x HCCH₂OCO); δ_C (125MHz; CDCl₃) -4.85 and -4.63 (Si(CH₃)₂), 17.96 (SiC(CH₃)₃), 21.05 and 24.64 (C(CH₃)₂), 25.70 (SiC(CH₃)₃), 65.90 (HCCH₂OCO), 71.63 (HCCH₂OCO), 115.50 (C(CH₃)₂), 156.36 and 160.65 (NC and C(CH₃)₂) and 168.05 (CO₂); m/z (chemical ionisation, NH₃) 582[(MNH₄)⁺, 12%], 565[(MH)⁺, 20], 132[51], 90[78] and 83[100].

6.2.2 Studies Towards the Synthesis of (±)-Isonitric C (Trichoviridin) (16)

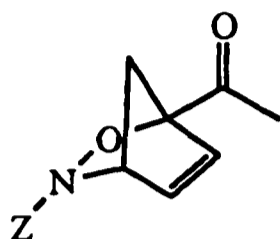
1-Acetyl-3-benzyloxycarbonyl-2-oxa-3-azabicyclo [2.2.1]hept-5-ene (331)

To a stirred solution of 6-methyl-6-trimethylsilyloxyfulvene (**327**)²¹⁵ (5.13g, 28.4mmol.) in anhydrous dichloromethane (60ml) at -40°C, under an inert atmosphere of argon, was added *p*-toluenesulfonic acid monohydrate (5.43g, 28.5mmol.) in four portions over four minutes. The resulting suspension was stirred at -40°C for forty minutes during which time the solution turned a burgundy colour. A solution of *N*-(benzyloxycarbonyl)hydroxylamine (**329**) (4.75g, 28.4mmol.) in anhydrous dichloromethane (70ml) was then added over fifteen minutes and this was followed by the dropwise addition of tetra-ethylammonium periodate (13.8g, 43.0mmol.) in anhydrous dichloromethane (70ml) over two hours. The dark brown solution was stirred at -40°C for a further one hour. Saturated aqueous Na₂S₂O₅ solution (200ml) was then added dropwise and the cooling bath removed. The two phase mixture was stirred vigorously until the organic phase had turned an orange colour. The organic phase was then separated and washed with saturated aqueous Na₂S₂O₅ (3 x 200ml) and saturated aqueous NaHCO₃ (200ml), dried (MgSO₄), filtered and concentrated *in vacuo* to afford *1-acetyl-3-benzyloxycarbonyl-2-oxa-3-azabicyclo[2.2.1]hept-5-ene* (**331**) as a pale yellow oil (7.63g, 98%); ν_{\max} (FT IR, Thin film, NaCl plates) 3034m, 2961m, 1740s and 1718s (2 x C=O), 1499m, 1456s, 1418s, 1386s, 1368s, 1340s, 1250s, 1208s, 1096s, 888s, 806s and 736s cm⁻¹; δ_{H} (200MHz; CDCl₃) 1.97 (1H, dd, *J* 1Hz, *J* 8.5Hz, 1 x CHCH₂), 2.20 (1H, dd, *J* 1.5Hz, *J* 8.5Hz, 1 x CHCH₂), 2.47 (3H, s, C(O)CH₃), 5.13-5.28 (3H, m, CH₂(C₆H₅) and CHCH₂), 6.41 (1H, dd, *J* 2Hz, *J* 5.5Hz, 1 x CH=CH), 6.48 (1H, dd, *J* 1.5Hz, *J* 5.5Hz, 1 x CH=CH) and 7.39 (5H, s, CH₂(C₆H₅)); δ_{C} (50MHz; CDCl₃) 26.90 (C(O)CH₃), 51.98 (CHCH₂), 67.12

($\underline{\text{C}}\text{HCH}_2$), 68.11 ($\underline{\text{C}}\text{H}_2(\text{C}_6\text{H}_5)$), 97.26 ($\underline{\text{C}}\text{C}(\text{O})\text{CH}_3$), 128.42, 128.67 and 128.78 (aromatic $\underline{\text{C}}\text{H}$), 133.80 and 134.88 ($\underline{\text{C}}\text{H}=\underline{\text{C}}\text{H}$), 135.66 (aromatic *ipso* $\underline{\text{C}}$), 159.14 ($\text{N}\underline{\text{C}}\text{O}_2\text{CH}_2(\text{C}_6\text{H}_5)$) and 201.55 ($\underline{\text{C}}(\text{O})\text{CH}_3$); m/z (desorption chemical ionisation, NH_3) 274[MH^+ , 10%], 230[40] and 93[100].

1-(1'-Hydroxyethyl)-3-benzyloxycarbonyl-2-oxa-3-bicyclo[2.2.1]hept-5-ene (332)

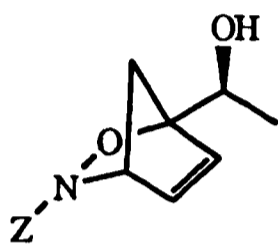

Major diastereoisomer

To a stirred solution of 1-acetyl-3-benzyloxycarbonyl-2-oxa-3-azabicyclo[2.2.1]hept-5-ene (331) (7.21g, 26.4mmol.) in anhydrous THF (120ml) under an inert atmosphere of argon was added K-Selectride[®] (27.7ml of a 1.0M solution in THF, 27.7mmol.) dropwise over twenty minutes. The solution was stirred at -100°C for forty minutes and the reaction mixture was then poured onto flash silica (*ca.* 100g). The mixture was concentrated *in vacuo* and the residue loaded to a flash chromatography column which was then eluted with P.E. 40-60: ethyl acetate 60: 40 to afford, as a mixture of epimers at the secondary hydroxyl centre in a ratio of approximately 6:1, 1-(1'-hydroxyethyl)-3-benzyloxycarbonyl-2-oxa-3-bicyclo[2.2.1]hept-5-ene (332) as a colourless oil (5.45g, 79%), (R_f 0.3, P.E 30-40:ethyl acetate 60:40); ν_{max} (FT IR, Thin film, NaCl plates) 3453br s (OH), 2976m, 1740s (C=O), 1455s, 1386s, 1283s, 1236s and 1096s cm^{-1} ; δ_{H} (200MHz; CDCl_3) 1.33 (3H, d, J 6.5Hz, $\text{CH}(\text{OH})\underline{\text{C}}\text{H}_3$, major isomer), 1.35 (3H, d, J 6.5Hz, $\text{CH}(\text{OH})\underline{\text{C}}\text{H}_3$, minor isomer), 1.63-1.73 (1H, m, 1 x CHCH_2 , major isomer and minor isomers), 1.84-1.90 (1H, m, 1 x CHCH_2 , minor isomer), 2.04 (1H, dd, J 1.5Hz, J 8.5Hz, 1 x CHCH_2 , major isomer), 2.67 (1H, br s, OH), 4.32-4.54 (1H, m, $\underline{\text{C}}\text{H}(\text{OH})\underline{\text{C}}\text{H}_3$), 5.09-5.12 (1H, m, $\underline{\text{C}}\text{HCH}_2$), 5.18 and 5.20 (2H, ABq, J 12Hz, $\underline{\text{C}}\text{H}_2(\text{C}_6\text{H}_5)$), 6.25 (1H, dd, J 1.5Hz, J 5.5Hz, 1 x $\underline{\text{C}}\text{H}=\underline{\text{C}}\text{H}$, major isomer), 6.35-6.42 (1H, m, $\underline{\text{C}}\text{H}=\underline{\text{C}}\text{H}$, major isomer and 1 x $\underline{\text{C}}\text{H}=\underline{\text{C}}\text{H}$, minor isomer), 6.48

(1H, dd, J 1.5Hz, J 5.5Hz, 1 x $\text{CH}=\text{CH}$, minor isomer) and 7.38 (5H, s, $\text{CH}_2(\text{C}_6\text{H}_5)$); δ_{C} (50MHz; CDCl_3) 18.13 ($\text{CH}(\text{OH})\text{CH}_3$, major isomer), 18.63 ($\text{CH}(\text{OH})\text{CH}_3$, minor isomer), 45.86 (CHCH_2 , major isomer), 48.20 (CHCH_2 , minor isomer), 64.16 and 66.24 ($\text{CH}(\text{OH})\text{CH}_3$ and CHCH_2 , major isomer), 65.41 and 66.51 ($\text{CH}(\text{OH})\text{CH}_3$ and CHCH_2 , minor isomer), 67.92 ($\text{CH}_2(\text{C}_6\text{H}_5)$), 99.10 ($\text{CCH}(\text{OH})\text{CH}_3$, minor isomer), 99.30 ($\text{CCH}(\text{OH})\text{CH}_3$, major isomer), 128.37, 128.56 and 128.74 (aromatic CH), 133.44 (1 x $\text{CH}=\text{CH}$, minor isomer), 133.95 and 134.85 ($\text{CH}=\text{CH}$, major isomer and 1 x $\text{CH}=\text{CH}$, minor isomer), 135.84 (aromatic *ipso* C) and 159.48 ($\text{NCO}_2\text{CH}_2(\text{C}_6\text{H}_5)$); m/z (chemical ionisation, NH_3) 276[(MH) $^+$, 5%], 232[15], 124[12], 108[20] and 93[100].

1-(^tButyldimethylsilyloxyethyl)-3-benzyloxy-carbonyl-2-oxa-3-aza-bicyclo [2.2.1]hept-5-ene
(333)

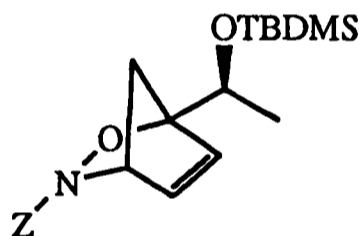

Major diastereoisomer

To a stirred solution of ^tbutyldimethylsilylchloride (5.11g, 33.9mmol.) and imidazole (5.96g, 87.5mmol.) in anhydrous DMF (50ml) under an inert atmosphere of argon was added 1-(1'-hydroxyethyl)-3-benzyloxycarbonyl-2-oxa-3-bicyclo[2.2.1]hept-5-ene (332) (4.67g, 16.9mmol.) as a solution in anhydrous DMF (50ml). The mixture was stirred at room temperature for twenty-four hours before being concentrated *in vacuo*. The residue was diluted with ether (500ml) and washed with H_2O (200ml), 1M HCl (2 x 200ml), saturated aqueous NaHCO_3 (200ml) and saturated aqueous NaCl (200ml). The organic phase was dried (MgSO_4), filtered and concentrated *in vacuo* to yield a brown oil. Flash chromatography (SiO_2 , P.E. 40-60:ethyl acetate; 90:10) afforded, as a mixture of epimers at the secondary hydroxyl centre in a ratio of approximately 6:1, 1-(^tbutyldimethylsilyloxyethyl)-3-benzyloxy-carbonyl-2-oxa-3-aza-bicyclo[2.2.1]hept-5-ene

(333) as a colourless oil (5.93g, 90%), (R_f 0.3, P.E 40-60:ethyl acetate 90:10); ν_{max} (FT IR, Thin film, NaCl plates) 2950m, 2930m, 2886m, 1747s (C=O), 1472s, 1463s, 1389s, 1347s, 1305s, 1254s, 1117s, 1095s and 834s cm^{-1} ; δ_H (200MHz; $CDCl_3$) 0.09 and 0.11 (6H, 2 x s, $Si(CH_3)_2$), 0.89 and 0.92 (9H, 2 x s, $SiC(CH_3)_3$), 1.32 (3H, d, J 6.5Hz, $CHCH_3$), 1.78 (1H, dd, J 1Hz, J 8.5Hz, 1 x $CHCH_2$), 1.88 (1H, dd, J 1.5Hz, J 8.5Hz, 1 x $CHCH_2$), 4.35 (1H, q, J 6.5Hz, $CHCH_3$), 5.00-5.05 (1H, m, $CHCH_2$), 5.16 and 5.17 (2H, ABq, J 12Hz, $CH_2(C_6H_5)$), 6.28-6.40 (2H, m, $CH=CH$) and 7.35 (5H, s, $CH_2(C_6H_5)$); δ_C (50MHz; $CDCl_3$) -4.99 and -4.80 ($Si(CH_3)_2$), 17.92 ($SiC(CH_3)_3$), 20.20 ($CHCH_3$), 25.66 ($SiC(CH_3)_3$), 47.29 ($CHCH_2$, minor isomer), 47.96 ($CHCH_2$, major isomer), 65.60 and 65.81 ($CHCH_3$ and $CHCH_2$), 67.56 ($CH_2(C_6H_5)$), 98.64 ($CHCH_3$), 128.17, 128.38 and 128.67 (aromatic CH), 133.91 and 134.28 ($CH=CH$, major isomer and 1 x $CH=CH$, minor isomer), 134.89 (1 x $CH=CH$, minor isomer), 136.15 (aromatic *ipso* C) and 159.35 ($NC(O)CH_2(C_6H_5)$); m/z (desorption chemical ionisation, NH_3) 390[(MH)⁺, 10%], 238[10], 223[15], 167[10], 108[10] and 93[100].

N-(Benzyloxycarbonyl)-1 α -(1'-*t*-butyldimethylsilyloxyethyl)-4 β -aminocyclopent-2-en-1 β -ol
(334)

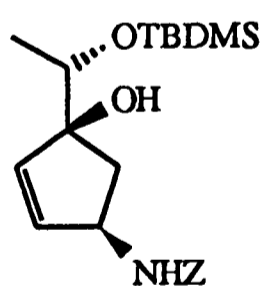

Major diastereoisomer

To a vigorously stirred solution of 1-(*t*-butyldimethylsilyloxyethyl)-3-benzyloxycarbonyl-2-oxa-3-aza-bicyclo[2.2.1]hept-5-ene (333) (3.33g, 8.55mmol.) in anhydrous methanol (200ml) under an inert atmosphere of argon was added Na_2HPO_4 (14.65g, 10.3mmol.) followed by freshly powdered 6% Na/Hg (40.11g). The mixture was stirred for two hours and then filtered through Celite[®] (eluting with ether) and then neutralised by the

addition of glacial acetic acid. The mixture was then concentrated *in vacuo* and the residue partitioned between ether (250ml) and saturated aqueous NaHCO₃ (250ml). The organic phase was separated, dried (MgSO₄), filtered and concentrated *in vacuo* to yield a colourless oil. Flash chromatography (SiO₂, P.E. 30-40:ether; 70:30) afforded, as a mixture of epimers at the secondary hydroxyl centre in a ratio of approximately 6:1, *N*-(benzyloxycarbonyl)-1 α -(1'-*t*-butyldimethylsilyloxyethyl)-4 β -aminocyclopent-2-en-1 β -ol as a colourless oil (334) (2.67g, 80%), (R_f 0.3, P.E. 30-40:ether; 70:30); ν_{\max} (FT IR, Thin film, NaCl plates) 3333br m (OH), 2955s, 2931s, 2857m, 1703s (C=O), 1526s, 1472m, 1463m, 1336s, 1256s, 1082s, 836s and 735s cm⁻¹; δ_{H} (200MHz; CDCl₃) 0.10 and 0.11 (6H, 2 x s, Si(CH₃)₂), 0.92 (9H, s, SiC(CH₃)₃), 1.14 (3H, d, *J* 6Hz, CHCH₃), 1.51-1.69 and 2.42-2.58 (2H, 2 x m, CHCH₂), 2.91 and 3.14 (1H, 2 x br s, OH, major and minor isomers respectively), 3.77 (1H, q, *J* 6Hz, CHCH₃), 4.58-4.78 (1H, m, CHCH₂), 5.00-5.08 (1H, m, NH), 5.12 (2H, s, CH₂(C₆H₅)), 5.75-5.91 (2H, m, CH=CH) and 7.38 (5H, s, CH₂(C₆H₅)); δ_{C} (50MHz; CDCl₃) -5.07 and -4.32 (Si(CH₃)₂), 17.85 (SiC(CH₃)₃), 17.96 and 18.22 (CHCH₃, major and minor isomers respectively), 25.70 (SiC(CH₃)₃), 41.52 and 42.68 (CHCH₂, major and minor isomers respectively), 55.20 and 73.05 (CHCH₃ and CHCH₂, minor isomer), 55.48 and 73.23 (CHCH₃ and CHCH₂, major isomer), 66.63 (CH₂(C₆H₅)), 86.89 (CCHCH₃), 128.27 and 128.70 (aromatic CH), 134.24 and 137.61 (CH=CH, major isomer), 134.77 and 136.86 (CH=CH, minor isomer), 136.86 (aromatic *ipso* C) and 156.05 (NCO₂CH₂(C₆H₅)); *m/z* (chemical ionisation, NH₃) 374[(M-OH)⁺, 100%], 284[71], 266[82], 242[83], 223[55], 108[71] and 91[40].

N-(Benzyloxycarbonyl)-1 α -(1'-*t*-butyldimethylsilyloxyethyl)-2 β , 3 β -epoxy-4 β -aminocyclopentan-1 β -ol (335)

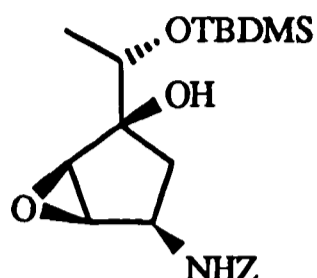

Major diastereoisomer

To a stirred solution of *N*-(benzyloxycarbonyl)-1 α -(1'-*t*-butyldimethylsilyloxyethyl)-4 β -amino cyclopent-2-en-1 β -ol (334) (3.33g, 8.51mmol.) in anhydrous dichloromethane (250ml) was added *m*-CPBA (3.23g, 9.35mmol., 50% pure). The resulting solution was stirred at room temperature for thirty-six hours before being concentrated *in vacuo*. The residue was dissolved in ethyl acetate (200ml) and washed with saturated aqueous NaHCO₃ (2 x 80ml), 10% aqueous Na₂CO₃ (80ml), H₂O (80ml) and saturated aqueous NaCl (80ml). The organic phase was separated, dried (MgSO₄), filtered and concentrated *in vacuo* to yield a yellow oil. Flash chromatography (SiO₂, P.E. 30-40:ether; 40:60) afforded, as a mixture of epimers at the secondary hydroxyl centre in a ratio of approximately 6:1, *N*-(benzyloxycarbonyl)-1 α -(1'-*t*-butyldimethylsilyloxyethyl)-2 β , 3 β -epoxy-4 β -aminocyclopentan-1 β -ol (335) as a pale yellow oil (3.11g, 90%), (R_f 0.3, P.E. 30-40:ether; 60:40); ν_{\max} (FT IR, Thin film, NaCl plates) 3339br m (OH), 2955s, 2857s, 1714s (C=O), 1531m, 1463m, 1339m, 1256s, 1094s and 833 cm⁻¹; δ_{H} (200MHz; CDCl₃) 0.11 (6H, s, Si(CH₃)₂), 0.92 (9H, s, SiC(CH₃)₃), 1.20 (3H, d, *J* 7Hz, CHCH₃, minor isomer), 1.21 (3H, d, *J* 6.5Hz, CHCH₃, major isomer), 2.07-2.31 (2H, m, CHCH₂), 2.58 and 2.62 (1H, 2 x s, OH, major and minor isomers respectively), 3.35-3.62 (2H, m, CHCH), 3.73-3.90 (1H, m, CHCH₃), 4.12-4.31 (1H, m, CHCH₂), 5.12 (2H, s, CH₂(C₆H₅)), 5.10-5.24 (1H, m, NH) and 7.36 (5H, s, CH₂(C₆H₅)); δ_{C} (50MHz; CDCl₃) -4.78 and -4.34 (Si(CH₃)₂), 15.26 and 18.00 (CHCH₃, minor and major isomers respectively), 17.90 (SiC(CH₃)₃), 25.80 (SiC(CH₃)₃), 34.53 and 35.94 (CHCH₂, minor and major isomers respectively),

51.05, 58.20, 59.70 and 71.82 ($\underline{\text{C}}\text{HCH}_3$, $\underline{\text{C}}\text{HCH}_2$ and $\underline{\text{C}}\text{H}\underline{\text{C}}\text{H}$, major isomer), 51.48, 58.98, 61.38 and 72.50 ($\underline{\text{C}}\text{HCH}_3$, $\underline{\text{C}}\text{HCH}_2$ and $\underline{\text{C}}\text{H}\underline{\text{C}}\text{H}$, minor isomer), 66.70 ($\underline{\text{C}}\text{H}_2(\text{C}_6\text{H}_5)$), 80.69 and 80.73 ($\underline{\text{C}}\text{CHCH}_3$, major and minor isomers respectively), 128.03 and 128.45 (aromatic $\underline{\text{C}}\text{H}$), 136.40 (aromatic *ipso* $\underline{\text{C}}$) and 155.98 ($\text{N}\underline{\text{C}}\text{O}_2\text{CH}_2(\text{C}_6\text{H}_5)$); m/z (chemical ionisation, NH_3) 408[(MH)⁺, 60%], 317[100], 300[58], 284[31], 159[30], 108[58] and 91[60].

1 α -(1'-*t*-Butyldimethylsilyloxyethyl)-2 β , 3 β -epoxy-4 β -aminocyclopentan-1 β -ol (336)

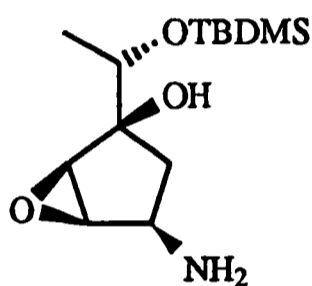

Major diastereoisomer

To a stirred, degassed solution of *N*-(benzyloxycarbonyl)-1 α -(1'-*t*-butyldimethylsilyloxyethyl)-2 β , 3 β -epoxy-4 β -aminocyclopentan-1 β -ol (335) (2.40g, 5.92mmol.) in anhydrous methanol (11ml) was added 10% Pd/C (100mg). The suspension was stirred under an atmosphere of hydrogen at room temperature for thirty minutes before being filtered through Celite[®] (eluting with dichloromethane) and concentrated *in vacuo* to afford, as a mixture of epimers at the secondary hydroxyl centre in a ratio of approximately 6:1, 1 α -(1'-*t*-butyldimethylsilyloxyethyl)-2 β , 3 β -epoxy-4 β -aminocyclopentan-1 β -ol (336) as a white solid (1.62g, quant.), m.p. 95-97°C; ν_{max} (FT IR, KBr disc) 3351br m and 3292br m (NH and OH), 2956s, 2931s, 2360s, 1473s, 1258s, 1141s, 1094s and 834 cm^{-1} ; δ_{H} (200MHz; CDCl_3) 0.09 and 0.11 (6H, 2 x s, $\text{Si}(\underline{\text{C}}\text{H}_3)_2$), 0.89 and 0.90 (9H, 2 x s, $\text{Si}(\underline{\text{C}}\text{H}_3)_3$), 1.17 and 1.20 (3H, 2 x d, 2 x *J* 6.5Hz, $\text{CH}\underline{\text{C}}\text{H}_3$, minor and major isomers respectively), 1.98-2.13 (2H, m, $\text{CH}\underline{\text{C}}\text{H}_2$), 2.47 (1H, br s, OH), 3.21-3.48 (3H, m, $\text{CH}\underline{\text{C}}\text{H}_2$ and $\text{CH}\underline{\text{C}}\text{H}$) and 3.70-3.88 (1H, m, $\text{CH}\underline{\text{C}}\text{H}_3$); δ_{C} (50MHz; CDCl_3) -4.89 and -4.29 ($\text{Si}(\underline{\text{C}}\text{H}_3)_2$), 17.31 ($\text{Si}\underline{\text{C}}(\text{CH}_3)_3$), 17.95 ($\text{CH}\underline{\text{C}}\text{H}_3$), 25.73 ($\text{Si}(\underline{\text{C}}\text{H}_3)_3$), 38.25 and 39.10

($\underline{\text{C}}\underline{\text{H}}\underline{\text{C}}\underline{\text{H}}_2$, minor and major isomers respectively), 52.05, 60.32, 61.12 and 71.78 ($\underline{\text{C}}\underline{\text{H}}\underline{\text{C}}\underline{\text{H}}_3$, $\underline{\text{C}}\underline{\text{H}}\underline{\text{C}}\underline{\text{H}}_2$ and $\underline{\text{C}}\underline{\text{H}}\underline{\text{C}}\underline{\text{H}}$, major isomer), 52.47, 60.06, 61.62 and 71.29 ($\underline{\text{C}}\underline{\text{H}}\underline{\text{C}}\underline{\text{H}}_3$, $\underline{\text{C}}\underline{\text{H}}\underline{\text{C}}\underline{\text{H}}_2$ and $\underline{\text{C}}\underline{\text{H}}\underline{\text{C}}\underline{\text{H}}$, minor isomer) and 81.11 and 81.24 ($\underline{\text{C}}\underline{\text{C}}\underline{\text{H}}\underline{\text{C}}\underline{\text{H}}_3$, major and minor isomers respectively); m/z (chemical ionisation, NH_3) 274 $[(\text{MH})^+]$, 100% and 124[22].

1α -(1'-*t*Butyldimethylsilyloxyethyl)-2 β , 3 β -epoxy-4-(*N*-*p*-toluenesulfinyl)cyclopentan-1 β -ol (324)

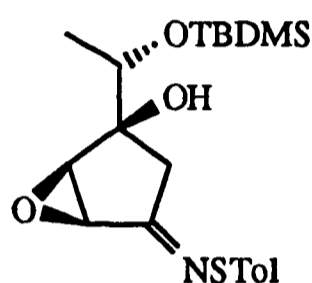

Major diastereoisomer

To a stirred solution of 1α -(1'-*t*butyldimethylsilyloxyethyl)-2 β , 3 β -epoxy-4 β -aminocyclopentan-1 β -ol (336) (1.62g, 5.92mmol.) in anhydrous dichloromethane (160ml) under an inert atmosphere of argon and cooled to 0°C was added propylene oxide (21ml, 0.3mol.) and crushed 4Å molecular sieves (22g). The mixture was allowed to stir for two minutes and then *p*-tolylsulfonyl chloride (2.81g, 17.8mmol.) was added as a solution in anhydrous dichloromethane (50ml). The mixture was stirred at 0°C for five minutes and then at room temperature for one hour before being quenched by the addition of saturated aqueous NaHCO_3 (80ml). The two phase mixture was stirred for five minutes before being filtered through Celite®. The organic phase was separated and washed with saturated aqueous NaHCO_3 (120ml), dried (MgSO_4), filtered and concentrated *in vacuo* to yield a brown oil. Flash chromatography (SiO_2 , P.E. 30-40:ether; 80:20) afforded, as a mixture of epimers at the secondary hydroxyl centre in a ratio of approximately 6:1, 1α -(1'-*t*butyldimethylsilyloxyethyl)-2 β , 3 β -epoxy-4-(*N*-*p*-toluenesulfinyl) cyclopentan-1 β -ol (324) as a yellow solid (2.12g, 91%), m.p. 84-85°C (P.E. 30-40), (R_f 0.3, P.E 30-40:ether 80:20); ν_{max} (FT IR, KBr disc) 3436br m (OH), 2952s, 2927s, 1645m (C=N), 1491s,

1254s, 1106s, 1080s and 834s cm^{-1} ; δ_{H} (200MHz; CDCl_3) 0.12 and 0.13 (6H, 2 x s, $\text{Si}(\text{CH}_3)_2$), 0.89 and 0.91 (9H, 2 x s, $\text{SiC}(\text{CH}_3)_3$), 1.23 (3H, d, J 6.5Hz, CHCH_3), 2.04 (1H, d, J 18Hz, 1 x $\text{CH}_2\text{C}(\text{OH})$, minor isomer), 2.10 (1H, d, J 18Hz, 1 x $\text{CH}_2\text{C}(\text{OH})$, major isomer), 2.37 (3H, s, $\text{S}(\text{C}_6\text{H}_4)\text{CH}_3$), 2.60 (1H, s, OH , major isomer), 2.62 (1H, s, $\text{CH}_2\text{C}(\text{OH})$, minor isomer), 2.71 (1H, d J 18Hz, 1 x $\text{CH}_2\text{C}(\text{OH})$, minor isomer), 2.74 (1H, d, J 18Hz, 1 x $\text{CH}_2\text{C}(\text{OH})$, major isomer), 3.72 (1H, d, J 2.5Hz, 1 x CHCH , minor isomer), 3.77 (1H, d, J 2.5Hz, 1 x CHCH , major isomer), 3.84 (1H, d, J 2.5Hz, 1 x CHCH , major isomer), 3.86 (1H, d, J 2.5Hz, 1 x CHCH , minor isomer), 3.93 (1H, q, J 6.5Hz, $\text{CH}(\text{CH}_3)$, major isomer), 3.98 (1H, q, J 6.5Hz, $\text{CH}(\text{CH}_3)$, minor isomer), 7.21 (2H, d, J 8Hz, 2 x $\text{S}(\text{C}_6\text{H}_4)\text{CH}_3$) and 7.45 (2H, d, J 8Hz, 2 x $\text{S}(\text{C}_6\text{H}_4)\text{CH}_3$); δ_{C} (50MHz; CDCl_3) -4.79 and -4.05 ($\text{Si}(\text{CH}_3)_2$), 17.88 ($\text{SiC}(\text{CH}_3)_3$), 18.00 and 21.15 ($\text{S}(\text{C}_6\text{H}_4)\text{CH}_3$ and CHCH_3), 25.77 ($\text{SiC}(\text{CH}_3)_3$), 36.69 and 38.87 ($\text{CH}_2\text{C}(\text{OH})$, minor and major isomers respectively), 59.37 and 60.76 (CHCH , major isomer), 59.71 and 62.31 (CHCH , minor isomer), 71.95 and 72.30 (CHCH_3 minor and major isomers respectively), 80.07 ($\text{C}(\text{OH})$), 126.98 and 129.70 (aromatic CH), 134.28 and 136.96 (2 x aromatic *ipso* C), 166.46 ($\text{C}=\text{NS}(\text{C}_6\text{H}_4)\text{CH}_3$); m/z (chemical ionisation, NH_3) 394[MH^+ , 15%], 378[100], 256[70], 240[30] and 124[35].

1 α -(1'-*t*-Butyldimethylsilyloxyethyl)-2 β , 3 β -epoxy-4-en-4-formamido-cyclopentan-1 β -ol (319)

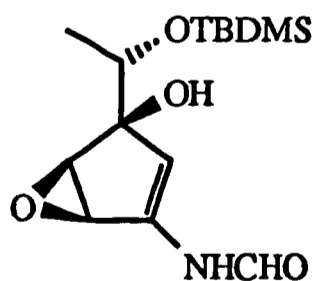

Major diastereoisomer

To a stirred solution of the 1 α -(1'-*t*-butyldimethylsilyloxyethyl)-2 β , 3 β -epoxy-4-(*N*-*p*-toluenesulfimine)cyclopentan-1 β -ol (324) (230mg, 0.58mmol.) in anhydrous

dichloromethane (8ml) under an inert atmosphere of argon was added propylene oxide (0.41ml, 5.8mmol.) and polymer supported triphenylphosphine (3mmol/g) (584mg, 1.75mmol.), followed by acetic formic anhydride (*ca.* 80% pure) (192mg, 1.75mmol.) as a solution in anhydrous dichloromethane (2ml). The mixture was stirred at room temperature for twenty-four hours before being quenched by the addition of saturated aqueous NaHCO₃ (2ml) and the two phase mixture was filtered. The organic phase was separated, washed with saturated aqueous NaHCO₃ (5ml), dried (Na₂SO₄), filtered and concentrated *in vacuo* to yield a yellow oil. The oil was dissolved in anhydrous dichloromethane (5ml) and cooled to 0°C under an inert atmosphere of argon. DBU (292µl, 2.92mmol.) was added dropwise over five minutes. The mixture was then stirred at room temperature for three hours before H₂O (3ml) was added. The organic phase was separated, dried (Na₂SO₄), filtered and concentrated *in vacuo* to yield a yellow oil. Reverse phase h.p.l.c. (water:methanol; 30:70, retention time-twenty minutes) afforded, as a mixture of epimers at the secondary hydroxyl centre in a ratio of approximately 6:1, *1α-(1'-^tbutyldimethylsilyloxyethyl)-2β, 3β-epoxy-4-en-4-formamido-cyclopentan-1β-ol* (319) as a yellow oil (105mg, 60%), *m/z* (high resolution) Found 300.1631, C₁₄H₂₅NO₄Si+H⁺ requires 300.1631; ν_{\max} (FT IR, Thin film, NaCl plates) 3311br m (OH), 2956m, 2931m, 2859m, 1702s and 1645s (amide C=O), 1519m, 1258s, 1145s, 1089s, 1007m, and 836s cm⁻¹; δ_{H} (200MHz; CDCl₃) 0.07 and 0.08 (6H, 2 x s, Si(CH₃)₂), 0.90 (9H, s, SiC(CH₃)₃), 1.25 (3H, d, *J* 6.5Hz, CHCH₃), 2.69 (1H, br s, OH), 3.60-4.00 (3H, m, CHCH and CHCH₃), 4.92 and 4.98 (1H, 2 x t, 2 x *J* 2.5Hz, CH=CNHCHO, minor rotamer, minor and major isomers respectively), 5.61 and 5.67 (1H, 2 x t, 2 x *J* 2.5Hz, CHC(NHCHO), major rotamer, major and minor isomers respectively), 7.10 (1H, br s, NHCHO, minor rotamer), 7.88 (1H, br s, NHCHO, major rotamer), 8.27 and 8.29 (1H, 2 x s, NHCHO, major rotamer, major and minor isomers respectively) and 8.57 (1H, d, *J* 11.5Hz, NHCHO, minor rotamer); *m/z* (chemical ionisation, NH₃) 300[MH⁺, 100%], 282[48], 255[39], 168[60] and 74[39].

1 α -(1'-^tButyldimethylsilyloxyethyl)-2 β , 3 β -epoxy-4-en-4-isocyano-cyclopentan-1 β -ol
(325)

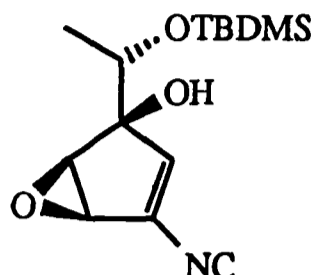

Method 1

To a stirred solution of 1 α -(1'-^tbutyldimethylsilyloxyethyl)-2 β , 3 β -epoxy-4-en-4-formamido-cyclopentan-1 β -ol (319) (37mg, 0.12mmol.) in anhydrous dichloromethane (1ml) under an inert atmosphere of argon and cooled to -78°C was added *N,N*-diisopropylethylamine (65 μ l, 0.37mmol.) followed by trifluoromethanesulfonic anhydride (31 μ l, 0.19mmol). The mixture was stirred at -78°C for twenty minutes and then saturated aqueous NaHCO₃ (1ml) was added and the two phase mixture was allowed to warm to room temperature. The organic phase was separated, washed with saturated aqueous NaHCO₃, dried (Na₂SO₄), filtered and concentrated *in vacuo*. Flash chromatography (SiO₂, P.E. 30-40:ether; 80:20) afforded 1 α -(1'-^tbutyldimethylsilyloxyethyl)-2 β , 3 β -epoxy-4-en-4-isocyano-cyclopentan-1 β -ol (325) as a yellow oil (25mg, 72%), (R_f 0.3, P.E 30-40:ether; 80:20); ν_{\max} (FT IR, CDCl₃ solution, NaCl plates) 3562m (OH), 2957s, 2932s, 2859s, 2121s (NC), 1258m, 1136m, 1093s and 927m cm⁻¹; δ_{H} (200MHz; CDCl₃) 0.10 and 0.12 (6H, 2 x s, Si(CH₃)₂), 0.91 (9H, s, SiC(CH₃)₃), 1.26 (3H, d, *J* 6.5Hz, CHCH₃), 2.46 (1H, s, OH), 3.74 (1H, t, *J* 2.5Hz, 1 x CHCH), 3.84 (1H, t, *J* 2.5Hz, 1 x CHCH), 3.95 (1H, q, *J* 6.5Hz, CH(CH₃)) and 5.83 (1H, t, *J* 2.5Hz, CHC(NC)); δ_{C} (50MHz; CDCl₃) -5.05 and -4.47 (Si(CH₃)₂), 14.10 (SiC(CH₃)₃), 17.70 (CHCH₃), 25.56 (SiC(CH₃)₃), 55.26 and 57.41 (CHCH), 70.55 (CHCH₃), 82.37 (C(OH)) and 136.76 (CHC(NC)); *m/z* (chemical ionisation, NH₃) 282[MH⁺, 100%], 255[M-NC, 40], 159[62], 91[65] and 74[50].

Method 2

To a stirred solution of the 1α -(1'-*t*-butyldimethylsilyloxyethyl)- 2β , 3β -epoxy-4-(*N*-*p*-toluenesulfimine)cyclopentan- 1β -ol (**324**) (450mg, 1.15mmol.) in anhydrous dichloromethane (10ml) under an inert atmosphere of argon was added propylene oxide (0.80ml, 11.5mmol.) and polymer supported triphenylphosphine (3mmol/g) (1.15mg, 3.44mmol.), followed by acetic formic anhydride (*ca.* 80% pure) (378mg, 3.44mmol.) as a solution in anhydrous dichloromethane (4ml). The mixture was stirred at room temperature for twenty-four hours before being quenched by the addition of saturated aqueous NaHCO_3 (3ml). The two phase mixture was filtered and the organic phase then separated, washed with saturated aqueous NaHCO_3 (5ml), dried (Na_2SO_4), filtered and concentrated *in vacuo* to yield a yellow oil. The oil was taken up in anhydrous dichloromethane (7ml) and cooled to 0°C under an inert atmosphere of argon. DBU (343 μl , 3.44mmol.) was added dropwise over five minutes and the mixture was stirred at room temperature for three hours before H_2O (3ml) was added. The organic phase was separated, dried (Na_2SO_4), filtered and concentrated *in vacuo* to yield a yellow oil. The oil was dissolved in anhydrous dichloromethane (10ml) under an inert atmosphere of argon at -78°C and to this solution was added *N, N*-diisopropylethylamine (599 μl , 3.44mmol.) followed by trifluoromethanesulfonic anhydride (385 μl , 2.29mmol.). The mixture was stirred at -78°C for thirty minutes then quenched by the addition of saturated aqueous NaHCO_3 (5ml). The two phase mixture was allowed to warm to room temperature and the organic phase was separated, washed with saturated aqueous NaHCO_3 (10ml) dried (Na_2SO_4), filtered and concentrated *in vacuo* to yield a brown oil. Flash chromatography (SiO_2 , P.E. 30-40:ether; 80:20) afforded 1α -(1'-*t*-butyldimethylsilyloxyethyl)- 2β , 3β -epoxy-4-en-4-isocyano-cyclopentan- 1β -ol (**325**) as a yellow oil (177mg, 55%). Spectral data were identical to those obtained for (**325**) prepared by method 1 above.

General procedure for the formation of thiooximes from ketones

To a stirred solution of ketone in anhydrous THF (10ml/mmol.) under an inert atmosphere of argon was added *N, N*-bis(trimethylsilyl)toluenesulfenamide (1.1 eq.) as a

solution in anhydrous THF (10ml/mmol.), followed by tetra-*n*-butylammonium fluoride (5mol%). The mixture was stirred at room temperature for twelve hours before being concentrated *in vacuo*. The residue was dissolved in dichloromethane and washed with saturated aqueous NaHCO₃, dried (MgSO₄), filtered and concentrated *in vacuo*.

N-(*p*-Toluenesulfinimine-4-phenylcyclohexylamine (346)

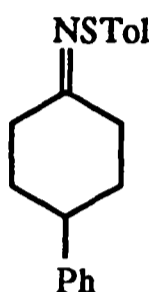

The general procedure was carried out with 4-phenylcyclohexanone (345) (438mg, 2.5mmol.) followed by recrystallisation from P.E. 30-40 to afford *N*-(*p*-toluenesulfinimine-4-phenylcyclohexylamine (346) as a white crystalline solid (631mg, 85%), (*R*_f 0.3, P.E 30-40: ether 98: 2), m.p. 68-70°C (P.E. 30-40, ether); ν_{\max} (KBr disc, NaCl plates) 3040m, 2991m, 2940m, 2879m, 1622s, 1580s, 1489m and 1400 cm⁻¹; δ_{H} (200MHz; CDCl₃) 1.72-2.25 (4H, m, CH₂CH(Ph)CH₂), 2.38 (3H, s, S(C₆H₄)CH₃), 2.26-3.12 (5H, m, CH₂C(NSTol)CH₂ and CH(Ph)) 7.12-7.48 (7H, m, 2 x S(C₆H₄)CH₃ and CH(C₆H₅)) and 7.49 (2H, d, *J* 8Hz, 2 x S(C₆H₄)CH₃); δ_{C} (50MHz; CDCl₃) 21.10 (S(C₆H₄)CH₃), 33.16, 33.67, 34.25 and 39.01 ((CH₂)₂CH(Ph)(CH₂)₂), 43.18 (CH(Ph)), 126.69, 127.07, 128.62, 128.83 and 129.94 (aromatic CH), 135.58, 136.38 and 145.88 (aromatic ipso C), and 170.40 (C=NSTol); *m/z* (chemical ionisation, NH₃) 296[MH⁺, 100%], 174[87] and 91[16].

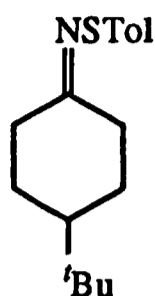
N-(*p*-Toluenesulfinimine-4-*t*butylcyclohexane (381)

The general procedure was carried out with 4-*t*butylcyclohexanone (380) (1.00g, 6.5mmol.) followed by recrystallisation from P.E. 30-40 to afford *N*-(*p*-toluenesulfinimine-4-*t*butylcyclohexane (381) as a white crystalline solid (1.43g, 80%), (R_f 0.5, P.E 30-40: ether 90: 10), m.p. 85-86°C (P.E. 30-40: ether), m/z (high resolution) Found 276.179. $C_{17}H_{25}NS+H^+$ requires 276.179; ν_{max} (KBr disc, NaCl plates) 2950m, 2865m, 2358m, 1617s, 1491m, 1447m, 1427m 1365m, 1115m and 1088m cm^{-1} ; δ_H (200MHz; $CDCl_3$) 1.01 (9H, s, $C(CH_3)_3$), 1.90-2.40 (4H, m, $CH_2CH(tBu)CH_2$), 2.35 (3H, s, $S(C_6H_4)CH_3$), 2.62-2.97 (5H, m, $CH_2C(NSTol)CH_2$ and $CH(tBu)$), 7.17 (2H, d, J 8Hz, 2 x $S(C_6H_4)CH_3$) and 7.44 (2H, d, J 8Hz, 2 x $S(C_6H_4)CH_3$); δ_C (50MHz; $CDCl_3$) 20.98 ($S(C_6H_4)CH_3$), 26.60, 33.68 and 38.88 ($(CH_2)_2CH(tBu)(CH_2)_2$), 27.50 ($C(CH_3)_3$), 32.44 ($C(CH_3)_3$), 46.92 ($CH(tBu)$), 126.60 and 129.77 (aromatic CH), 135.62 and 136.20 (aromatic *ipso* C) and 171.91 ($C=NSTol$); m/z (chemical ionisation, NH_3) 276[MH^+ , 100%] and 154[70].

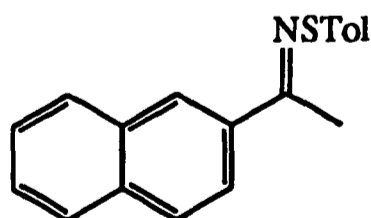
N-1-(1-(2-Naphthylethylidene)toluenesulfenamide (386)

The general procedure was carried out with 2-naphthylacetophenone (385) (362mg, 2.1mmol.) followed by recrystallisation from P.E. 30-40 to afford *N*-1-(1-(2-

naphthylethylidene)toluenesulfenamide (386) as a white crystalline solid (464mg, 75%), (R_f 0.3, P.E. 30-40: ether 80: 20), m.p. 116-117°C (P.E. 30-40: ether); ν_{max} (FT IR, $CDCl_3$ solution, NaCl plates) 3023m, 2979m, 2920m, 1599s, 1584m, and 1371m cm^{-1} ; δ_H (200MHz; $CDCl_3$) 2.40 and 2.61 (6H, 2 x s, $C(NS(C_6H_4)CH_3)CH_3$ and $S(C_6H_4)CH_3$), 7.22-7.28, 7.65-7.63, 7.80-7.95, 8.10-8.21 (11H, 4 x m, aromatic CH); δ_C (50MHz; $CDCl_3$) 19.95 and 20.50 ($C(NS(C_6H_4)CH_3)CH_3$ and $S(C_6H_4)CH_3$), 122.00, 122.89, 123.50, 123.54, 123.98, 124.10, 124.54 and 125.06 (aromatic CH), 126.75 and 127.05, 128.20 and 128.50 (aromatic ipso C), 160.66 ($C(NS(C_6H_4)CH_3)$); m/z (chemical ionisation, NH_3) 292[MH⁺, 75%] and 170[100].

General procedure for the preparation of vinyl formamides from thiooximes

To a stirred solution of thiooxime (400mg, 1.35mmol.) in anhydrous dichloromethane (10ml/mmol.), under an inert atmosphere of argon, was added propylene oxide (10 eq.), triphenylphosphine (3 eq.) followed by acetic formic anhydride (*ca.* 80% pure) (3 eq.) as a solution in anhydrous dichloromethane (2ml/mmol.). The reaction mixture was stirred at room temperature for twenty-four hours before being quenched by the addition of saturated aqueous $NaHCO_3$. The organic phase was separated, washed with saturated aqueous $NaHCO_3$, dried (Na_2SO_4), filtered and concentrated *in vacuo*.

1-Formamido-4-phenylcyclohex-1-ene (347)

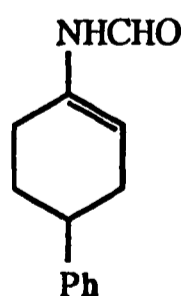

The general procedure with *N*-(*p*-toluenesulfimine-4-phenylcyclohexane (346) (400mg, 1.35mmol.) followed by flash chromatography (SiO_2 , P.E. 40-60:ether; 20:80) afforded 1-formamido-4-phenylcyclohex-1-ene (347) as a white crystalline solid (231mg,

85%), (R_f 0.3, P.E. 30-40: ether 20: 80), m.p. 154-156°C (from P.E. 30-40: dichloromethane), (Found: C, 77.47; H, 7.37; N, 6.52. $C_{13}H_{15}NO$ requires C, 77.58; H, 7.51; N, 6.96%); ν_{max} (FT IR, KBr disc) 3188m, 3053m, 2930m, 1696s (C=O), 1494m, 1380s, 1325s, 1305s and 754m cm^{-1} ; δ_H (200MHz; $CDCl_3$) 1.78-2.92 (7H, m, $((CH_2)_2CH(Ph)CH_2)$), 5.40 (1H, m, $CH=CNHCHO$), 6.21-6.32 and 6.86-7.00 (1H, 2 x m, $NHCHO$, minor and major rotamers respectively), 7.15-7.29 (5H, m, $CH(C_6H_5)$), 8.21 (1H, s, $NHCHO$, minor rotamer) and 8.44 (1H, d, J 12Hz, major rotamer); δ_C (50MHz; $CDCl_3$) 27.12, 29.13, 31.89 ($(CH_2)_2CH(Ph)CH_2$, major rotamer), 28.42, 29.28, 31.90 ($(CH_2)_2CH(Ph)CH_2$, minor rotamer), 39.46 ($(CH_2)_2CH(Ph)CH_2$, minor rotamer), 39.56 ($(CH_2)_2CH(Ph)CH_2$, major rotamer), 109.90 and 113.47 ($CH=CNHCHO$, major and minor rotamers respectively), 126.19, 126.33, 126.76, 128.47 (aromatic CH), 131.59 and 132.44 ($CNHCHO$, minor and major rotamers respectively), 145.71 (aromatic *ipso* C) and 159.00 and 161.38 ($NHCHO$, minor and major rotamers respectively); m/z (chemical ionisation, NH_3) 219[MNH_4^+ , 20%], 202[MH^+ , 100] and 104[18].

1-Formamido-4-*t*-butylcyclohex-1-ene (382)

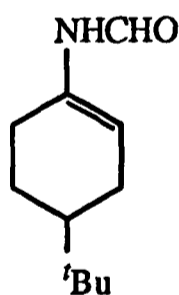

The general procedure with *N*-(*p*-toluenesulfinimine-4-*t*-butylcyclohexane (381) (684mg, 2.49mmol.) followed by flash chromatography (SiO_2 , P.E. 40-60:ether; 20:80) afforded 1-*formamido-4-t*-butylcyclohex-1-ene (382) as a white crystalline solid (383mg, 85%), (R_f 0.2, P.E. 30-40: ether 20: 80), m.p. 125-126°C (from P.E. 30-40: dichloromethane), m/z (high resolution) Found 181.155. $C_{11}H_{19}NO+H^+$ requires 181.155; ν_{max} (FT IR, KBr disc) 3051m, 2968m, 2953m, 1698s (C=O), 1674m, 1476m, 1377s, 1329s, 1305s and 886m cm^{-1} ; δ_H (200MHz; $CDCl_3$) 0.89 (9H, s, $C(CH_3)_3$), 1.15-2.35

(7H, m, ((CH₂)₂CH(Ph)CH₂), 5.27-5.34 and 6.10-6.19 (1H, m, CH=CNHCHO, major and minor rotamers respectively) 6.30-6.50 and 6.39-7.60 (1H, 2 x m, NHCHO, minor and major rotamers respectively), 8.18 (1H, s, NHCHO, minor rotamer) and 8.38 (1H, d, *J* 11.5Hz, NHCHO, major rotamer); δ_C (50MHz; CDCl₃) 23.38, 25.24, 29.07 ((CH₂)₂CH(^tBu)CH₂, minor rotamer), 23.55, 25.23, 27.64 ((CH₂)₂CH(^tBu)CH₂, major rotamer), 27.08 (C(CH₃)₃), 32.02 (C(CH₃)₃), 43.47 ((CH₂)₂CH(^tBu)CH₂, minor rotamer), 43.68 ((CH₂)₂CH(^tBu)CH₂, major rotamer), 110.65 and 114.02 (CH=CNHCHO, major and minor rotamers respectively), 131.00 and 132.78 (CNHCHO, minor and major rotamers respectively) and 159.56 and 162.04 (NHCHO, minor and major rotamers respectively); *m/z* (chemical ionisation, NH₃) 199[MNH₄⁺, 30%] and 182[MH⁺, 100].

1-(2'-Naphthyl)ethenyl-1-formamide (387)

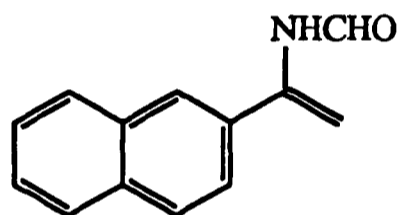

The general procedure with *N*-1-(1-(2-naphthylethylidene)toluenesulfenamide (386) (150mg, 0.52mmol.) followed by flash chromatography (SiO₂, P.E. 40-60:ether; 30:70) afforded 1-(2'-naphthyl)ethenyl-1-formamide (387) as a white crystalline solid (76mg, 75%), (R_f 0.3, P.E 30-40: ether 30: 70), m.p. 104-105°C; ν_{max} (FT IR, KBr disc) 3289m, 1701s, 1674s, 1412s, 1118m and 826m cm⁻¹; δ_H (200MHz; CDCl₃) 5.01 (1H, d, *J* 9.5Hz, HC=CNHCHO, major rotamer), 5.36 (1H, s, HC=CNHCHO, minor rotamer), 6.08 (1H, s, NHCHO), 7.50-7.67, 7.82-8.00 and 8.55-8.62 (7H, 3 x m, aromatic CH); δ_C (50MHz; CDCl₃) 100.73 and 104.33 (HC=CNHCHO), 123.88, 126.75, 126.88, 127.65, 128.34, 128.60 (aromatic CH, major rotamer), 124.70, 125.73, 128.15 and 129.92 (aromatic CH, minor rotamer), 133.03, 133.16, 133.63, 137.38 and 141.32 (3 x aromatic ipso C and CNHCHO), 159.89 and 163.35 (NHCHO, minor and major rotamers respectively); *m/z* (chemical ionisation, NH₃) 198[MH⁺, 100%] and 170[12].

General procedure for the preparation of vinyl isonitriles from vinyl formamides

To a stirred solution of vinyl formamide in anhydrous dichloromethane (10ml/mmol) under an inert atmosphere of argon and cooled to -78°C was added *N, N*-diisopropylethylamine (3 eq.) followed by trifluoromethanesulfonic anhydride (1.5 eq). The mixture was stirred at -78°C for twenty minutes and then saturated aqueous NaHCO_3 was added and the two phase mixture was allowed to warm to room temperature. The organic phase was separated, washed with saturated aqueous NaHCO_3 , dried (Na_2SO_4), filtered and concentrated *in vacuo*.

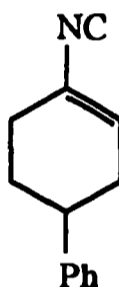
1-Isocyano-4-phenyl cyclohex-1-ene (349)

The general procedure with 1-formamido-4-phenyl cyclohex-1-ene (347) (15mg, 7.43mmol.) followed by flash chromatography (SiO_2 , P.E. 30-40: ether; 95: 5) afforded *1-isocyano-4-phenyl cyclohex-1-ene* (349) as a yellow crystalline solid (11mg, 81%), m.p. $85-87^{\circ}\text{C}$, (R_f 0.4, P.E 30-40:ether 95:5); ν_{max} (FT IR, CDCl_3 solution, NaCl plates) 2935m , 2226m , 2246m , 2117s (NC), 1497m , 1455m , 1371m , 1224s , 1020m and 986s cm^{-1} ; δ_{H} (200MHz; CDCl_3) 1.20-2.90 (7H, m, $((\text{CH}_2)_2\text{CH}(\text{Ph})\text{CH}_2)$), 6.15 (1H, m, $\text{CHC}(\text{NC})$) and 7.15-7.39 (5H, m, $\text{CH}(\text{C}_6\text{H}_5)$); m/z (GCMS, electron impact) 183[M^+ , 100%] and 157[20].

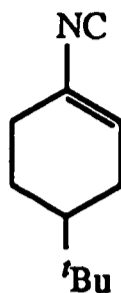
1-Isocyano-4-*t*-butyl cyclohex-1-ene (383)

The general procedure with 1-formamido-4-*t*-butylcyclohex-1-ene (382) (234mg, 1.29mmol.) followed by flash chromatography (SiO₂, P.E. 30-40:ether; 95:5) afforded 1-isocyano-4-*t*-butylcyclohex-1-ene (383) as a yellow crystalline solid (137mg, 65%), m.p. 93-96°C, (R_f 0.3, P.E. 30-40:ether 95:5); ν_{\max} (FT IR, CDCl₃ solution, NaCl plates) 2964s, 2870s, 2115s (NC), 1368m and 927m cm⁻¹; δ_{H} (200MHz; CDCl₃) 0.89 (9H, s, C(CH₃)₃), 1.20-2.20 (7H, m, ((CH₂)₂CH(*t*Bu)CH₂)) and 6.02-6.10 (1H, m, HC=C(NC)); δ_{C} (50MHz; CDCl₃) 23.17, 25.73 and 29.63 ((CH₂)₂CH(*t*Bu)CH₂), 27.05 (C(CH₃)₃), 32.07 (C(CH₃)₃), 42.73 ((CH₂)₂CH(*t*Bu)CH₂) and 129.24 (CH=CNC); m/z (GCMS, electron impact) 163[M⁺, 100%].

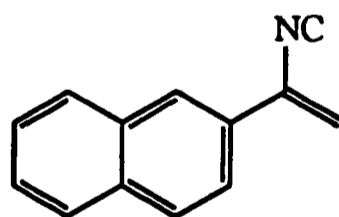
1-(2-Naphthyl)ethenyl-1-isonitrile (388)

The general procedure with 1-(2'-naphthyl)ethenyl-1-formamide (387) (27mg, 0.13mmol.) followed by flash chromatography (SiO₂, P.E. 30-40:ether; 95:5) afforded 1-(2-naphthyl)ethenyl-1-isonitrile (388) as a brown crystalline solid (11mg, 81%), m.p. 79-80°C (P.E. 30-40), (R_f 0.3, P.E. 30-40: ether 95: 5); ν_{\max} (FT IR, Thin film, NaCl plates) 2961m, 2247m, 2122s (NC), 1618m, 1265m, 1196m, 1134m, 927m, 890s, 861s and 657s cm⁻¹; δ_{H} (200MHz; CDCl₃) 5.75 and 5.98 (2H, 2 x s, H₂C=CNC) and 7.52-8.18 (7H, m,

aromatic CH); m/z (chemical ionisation, NH₃) 197[MNH₄⁺, 5%], 170[100] and 153[M-NC, 55].

Dimethyldioxirane solution (357)

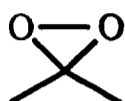

A one litre, 3 neck flask was equipped with a solid addition funnel, a large magnetic stirring bar and a 20cm air cooled condenser which was connected to a dry ice/acetone condenser. A 100ml flask attached to the dry ice condenser was also cooled to -78°C. The one litre flask was charged with NaHCO₃ (80g), H₂O (130ml) and acetone (90ml). The solid addition funnel was charged with Oxone[®] (160g) which was added in *ca.* 15g portions over 20 minutes. Vigorous stirring was continued for twenty minutes and then a vacuum (*ca.* 40mmHg) was applied and the dimethyldioxirane/acetone solution (*ca.* 50ml) was collected. The dioxirane solution was then passed through a plug of glass wool and stirred at 0°C over 4Å molecular sieves under an inert atmosphere of argon for thirty minutes. The solution was then decanted onto fresh 4Å molecular sieves and stored at -20°C. The dioxirane solution was titrated using the following procedure: To thioanisole (172g, 1.38mmol.) in acetone (2ml) was added the dimethyldioxirane solution (5ml). The mixture was then stirred for twenty minutes before being concentrated *in vacuo*. Comparison of the integrals of the CH₃ group of thioanisole and the corresponding sulfoxide in the 200MHz ¹H n.m.r. (CDCl₃) indicated that the titration of the dioxirane solution was typically 0.08-0.1M.

Methyl(trifluoromethyl)dioxirane solution (359)

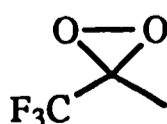

A 100ml three necked flask was equipped with a solid addition funnel, a large magnetic stirring bar, a gas inlet tube and a cold finger which was cooled to -78°C . The cold finger was also attached to a water aspirator. The flask was charged with NaHCO_3 (5g), deionised H_2O (5ml), $\text{Na}_2\text{H}_2\text{EDTA}$ (167mg) and 1,1,1-trifluoroacetone (*ca.* 6ml) and cooled to 0°C . The solid addition funnel was charged with Oxone[®] (8.3g), a vacuum of *ca.* 700mmHg was applied and with a steady stream of argon the Oxone[®] was added over three minutes. Stirring was continued for a further eight minutes during which time the methyl(trifluoromethyl)dioxirane/1,1,1-trifluoroacetone solution was collected (*ca.* 3ml). The solution was then filtered through a glass wool plug and stirred at -20°C over 4Å molecular sieves under an inert atmosphere of argon for thirty minutes. The solution was then decanted onto fresh 4Å molecular sieves and stored at -20°C . The titration of the dioxirane solution was assumed to be the typical literature value of 0.5M.²⁶⁵

1-Isocyano-1-epoxy-4-phenyl cyclohexane (348)



Method 1

To a stirred solution of 1-formamido-4-phenylcyclohex-1-ene (**347**) (36mg, 0.17mmol.) in anhydrous dichloromethane (5ml) under an inert atmosphere of argon and cooled to -40°C was added dimethyldioxirane solution (5.1ml of a 0.1M solution, 0.51mmol.). The mixture was stirred at -40°C for ten minutes and then *N,N*-diisopropylethylamine (298 μl , 1.7mmol.) was added and the mixture stirred for a further 2 minutes before being cooled to -78°C . Trifluoromethanesulfonic anhydride (13 μl , 0.8mmol.) was added and stirring continued at -78°C for twenty minutes before saturated aqueous NaHCO_3 (3ml) was added. The two phase mixture was allowed to warm to room

temperature and the organic phase was separated, washed with saturated aqueous NaHCO_3 (20ml) dried (Na_2SO_4), filtered and concentrated *in vacuo* to yield a brown oil. Flash chromatography (SiO_2 , P.E. 30-40:ether; 95:5) afforded *1-isocyano-1-epoxy-4-phenylcyclohexane* (**348**) (25mg, 74%) as a yellow crystalline solid, (R_f 0.3, P.E. 30-40: ether 95: 5), m/z (high resolution) Found 217.1341, $\text{C}_{13}\text{H}_{13}\text{NO}+\text{NH}_4^+$ requires 217.1341; ν_{max} (FT IR, CDCl_3 solution, NaCl plates) 2363m, 2135s (NC), 1455m, 1431m, 1116m, 1020m, 954m and 705m cm^{-1} ; δ_{H} (200MHz; CDCl_3) 0.85-2.88 (7H, m, $((\text{CH}_2)_2\text{CH}(\text{Ph})\text{CH}_2)$), 3.61 (1H, d, J 5Hz, $\text{CHC}(\text{NC})$, isomer A) and 3.71 (1H, t, J 2Hz, $\text{CHC}(\text{NC})$, isomer B) and 7.13-7.40 (5H, m, $\text{CH}(\text{C}_6\text{H}_5)$); δ_{C} (50MHz; CDCl_3) 25.99, 27.34, 28.90, 29.98, 31.67, $((\text{CH}_2)_2\text{CH}(\text{Ph})\text{CH}_2)$, 34.46 and 38.50 $((\text{CH}_2)_2\text{CH}(\text{Ph})\text{CH}_2)$, 59.14 and 60.89 ($\text{CHC}(\text{NC})$), 62.00 ($\text{C}(\text{NC})$), 126.62, 126.73 and 128.68 (aromatic CH), 143.93 and 144.37 (aromatic *ipso* C) and 159.42 and 159.86 ($\text{C}(\text{NC})$); m/z (chemical ionisation, NH_3) 217[MNH_4^+ , 75%], 200[MH^+ , 30] and 173[100].

Method 2

To a stirred solution of 1-formamido-4-phenylcyclohex-1-ene (**347**) (8mg, 0.04mmol.) in anhydrous dichloromethane (1ml) under an inert atmosphere of argon and cooled to -78°C was added propylene oxide (28 μl , 0.4mmol.) followed by methyl(trifluoromethyl)dioxirane solution (240 μl of a 0.5M solution, 0.12mmol.). The mixture was stirred at -78°C for ten minutes before *N,N*-diisopropylethylamine (70 μl , 0.4mmol.) was added. The mixture was then stirred for a further one minute before trifluoromethanesulfonic anhydride (13 μl , 0.8mmol.). Stirring was continued at -78°C for twenty minutes before saturated aqueous NaHCO_3 (1ml) was added. The two phase mixture was allowed to warm to room temperature and the organic phase was separated, washed with saturated aqueous NaHCO_3 (10ml) dried (Na_2SO_4), filtered and concentrated *in vacuo* to yield a brown oil. Flash chromatography (SiO_2 , P.E. 30-40:ether; 95:5) afforded *1-isocyano-1-epoxy-4-phenylcyclohexane* (**348**) (6mg, 76%) as a yellow crystalline solid, which had identical physical and spectral properties to (**347**) formed by method 1 above.

1 α -(1'-^tButyldimethylsilyloxyethyl)-2 β , 3 β -epoxy-1 β -(trimethylsilyloxy)-4-en-4-formamido-cyclopentane (373)

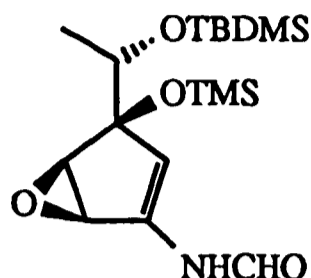

Major diastereoisomer

To 1 α -(1'-^tbutyldimethylsilyloxyethyl)-2 β , 3 β -epoxy-4-en-4-formamido-cyclopentan-1 β -ol (**319**) (5mg, 0.017mmol.) in anhydrous DMF (20 μ l), under argon was added trimethylsilylcyanide (200 μ l) and the mixture was stirred at room temperature for five minutes. Argon was then bubbled through the mixture until all the excess trimethylsilylcyanide and DMF had evaporated to afford 1 α -(1'-^tbutyldimethylsilyloxyethyl)-2 β , 3 β -epoxy-1 β -(trimethylsilyloxy)-4-en-4-formamido-cyclopentane (**373**) as a yellow oil (7mg, quant.), m/z (high resolution) Found 372.2026, C₁₇H₃₃NO₄Si+H⁺ requires 372.2026; ν_{\max} (FT IR, Thin film, NaCl plates), 3427m, 2958m, 2931m, 1708s (C=O), 1646m, 1518m, 1252s, 1111s and 841s cm⁻¹; δ_{H} (200MHz; CDCl₃) 0.08 and 0.09 (6H, 2 x s, Si(CH₃)₂), 0.13 (9H, s, Si(CH₃)₃), 0.87 (9H, s, SiC(CH₃)₃), 1.18 and 1.25 (3H, 2 x d, 2 x *J* 6.5Hz, CHCH₃, minor and major rotamers respectively), 3.58-3.90 (3H, m, CHCH and CH(CH₃)), 4.87 and 4.92 (1H, 2 x t, 2 x *J* 2.5Hz, CH=CNHCHO, minor rotamer, minor and major isomers respectively), 5.51 and 5.62 (1H, 2 x t, 2 x *J* 2.5Hz, CHC(NHCHO), major rotamer, major and minor isomers respectively), 7.00 and 7.50 (1H, 2 x br s, NHCHO, minor and major rotamers respectively), 8.30 (1H, s, NHCHO, major rotamer), 8.58 (1H, d, *J* 12Hz, NHCHO, minor rotamer); m/z (chemical ionisation, NH₃) 372[MH⁺, 10%], 296[34], 282[100], 254[28], 240[26], 152[31] and 90[32].

1 α -(1'-^tButyldimethylsilyloxyethyl) 1 β -(methyl(trifluoromethyl)hemiacetal)-2 β , 3 β -epoxy-4-isocyano-5-keto-cyclopentane (363)

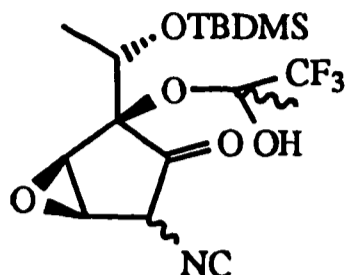

To a stirred solution of 1 α -(1'-^tbutyldimethylsilyloxyethyl)-2 β , 3 β -epoxy-4-en-4-formamidocyclopentan-1 β -ol (319) (7mg, 0.02mmol.) in anhydrous dichloromethane (1ml) under an inert atmosphere of argon and cooled to -78°C was added propylene oxide (164 μ l, 2.3mmol.) followed by methyl(trifluoromethyl)dioxirane solution (359) (92 μ l of a 0.5M solution, *ca.* 0.05mmol.). The mixture was stirred at -78°C for ten minutes before *N,N*-diisopropylethylamine (41 μ l, 0.23mmol.) was added. The mixture was then stirred for a further one minute before trifluoromethanesulfonic anhydride (6 μ l, 0.035mmol.) was added. Stirring was continued at -78°C for twenty minutes before saturated aqueous NaHCO₃ (1ml) was added. The two phase mixture was allowed to warm to room temperature and the organic phase was separated, washed with saturated aqueous NaHCO₃ (10ml), dried (Na₂SO₄), filtered and concentrated *in vacuo* to yield a brown oil. Flash chromatography (SiO₂, P.E. 30-40:ether; 90:10) afforded firstly the minor isomer of 1 α -(1'-^tbutyldimethylsilyloxyethyl) 1 β -(methyl(trifluoromethyl)hemiacetal)-2 β , 3 β -epoxy-4-isocyano-5-keto-cyclopentane (363) as a yellow oil (1.5mg, 16%), (R_f 0.3, P.E 30-40:ether 90:10), ν_{\max} (FT IR, Thin film, NaCl plates) 2953m, 2132s (NC), 1735s (C=O), 1387s, 1117s and 927m cm⁻¹; δ_{H} (200MHz; CDCl₃) 0.16 (6H, s, Si(CH₃)₂), 0.92 (9H, s, SiC(CH₃)₃), 1.33 (3H, d, *J* 6.5Hz, CHCH₃), 1.73 (3H, s, C(CH₃)(CF₃)), 2.83 (1H, s, OH), 3.70 and 3.77 (2H, 2 x d, 2 x *J* 2.5Hz, CHCH) and 4.65 (1H, s, CH(NC)); δ_{F} (235MHz; CDCl₃) -84.02 (CF₃); *m/z* (chemical ionisation, NH₃) 427[MNH₄⁺, 23%], 400[18], 383[12], 159[100], 132[72] and 91[45] and then the major isomer of 1 α -(1'-^tbutyldimethylsilyloxyethyl) 1 β -(methyl(trifluoromethyl)hemiacetal)-2 β , 3 β -epoxy-4-isocyano-5-keto-cyclopentane (363) as a yellow oil (5mg, 52%), (R_f 0.2, P.E 30-40:ether 90:10); *m/z* (high resolution) Found

427.1876, $C_{17}H_{26}F_3NO_5Si+NH_4^+$ requires 427.1876; ν_{max} (FT IR, Thin film, NaCl plates) 2979m, 2132m (NC), 1736s (C=O), 1385s, 1114s and 927m cm^{-1} ; δ_H (200MHz; $CDCl_3$) 0.15 (6H, s, $Si(CH_3)_2$), 0.92 (9H, s, $SiC(CH_3)_3$), 1.35 (3H, d, J 6.5Hz, $CHCH_3$), 1.72 (3H, s, $C(CH_3)(CF_3)$), 2.91 (1H, s, OH), 3.68 and 3.75 (2H, 2 x d, 2 x J 2.5Hz, $CHCH$) and 4.72 (1H, s, $CH(NC)$); δ_F (235MHz; $CDCl_3$) -83.66 (CF_3); m/z (chemical ionisation, NH_3) 427[MNH $_4^+$, 20%], 400[12], 383[13], 159[100], 132[76] and 91[54].

1 α -(1'-*t*-Butyldimethylsilyloxyethyl)-2 β , 3 β -epoxy-4-en-4-dichloroimino-cyclopentan-1 β -ol (391)

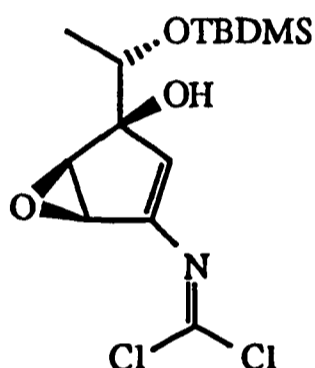

To a stirred solution of 1 α -(1'-*t*-butyldimethylsilyloxyethyl)-2 β , 3 β -epoxy-4-en-4-isocyanocyclopentan-1 β -ol (325) (6mg, 0.021mmol.) in anhydrous carbontetrachloride (200 μ l) under an inert atmosphere of argon at room temperature was added chlorine (28 μ l of a 0.76M solution in anhydrous carbontetrachloride, 0.021mmol.). The mixture was stirred at room temperature for two hours in the dark before being concentrated *in vacuo* to afford 1 α -(1'-*t*-butyldimethylsilyloxyethyl)-2 β , 3 β -epoxy-4-en-4-dichloroimino-cyclopentan-1 β -ol (391) as a yellow oil, (8mg, quant.); ν_{max} (FT IR, $CDCl_3$ solution, NaCl plates) 3556br m (OH), 2956s, 2931s, 1651s (N=C), 1258m and 927m cm^{-1} ; δ_H (200MHz; $CDCl_3$) 0.10 and 0.12 (6H, 2 x s, $Si(CH_3)_2$), 0.91 (9H, s, $SiC(CH_3)_3$), 1.25 (3H, d, J 6.5Hz, $CHCH_3$), 2.51 (1H, s, OH), 3.70 (1H, t, J 2.5Hz, 1 x $CHCH$), 3.89 (1H, t, J 2.5Hz, 1 x $CHCH$), 3.93 (1H, q, J 6.5Hz, $CH(CH_3)$) and 5.41 (1H, t, J 2.5Hz, $CHC(NCCl_2)$).

1 α -(1'-*t*-Butyldimethylsilyloxyethyl)-2 β , 3 β -epoxy-4-en-4-dibromoiminocyclopentan-1 β -ol
(408)

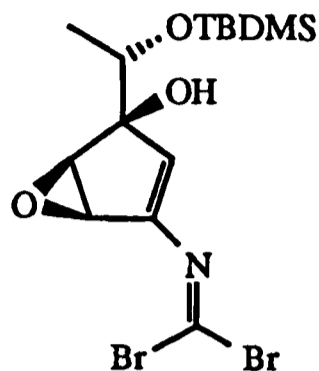

To a stirred solution of 1 α -(1'-*t*-butyldimethylsilyloxyethyl)-2 β , 3 β -epoxy-4-en-4-isocyanocyclopentan-1 β -ol (325) (35mg, 0.12mmol.) in anhydrous dichloromethane (0.1ml) was added polymer supported bromine (1.4mmol/g) (89mg, 0.12mmol.). The mixture was stirred at room temperature for two hours in the dark before being concentrated *in vacuo* to afford 1 α -(1'-*t*-butyldimethylsilyloxyethyl)-2 β , 3 β -epoxy-4-en-4-dibromoiminocyclopentan-1 β -ol (408) as a yellow oil (55mg, quant.); ν_{\max} (FT IR, CDCl₃ solution, NaCl plates) 3557br m (OH), 2956s, 2931s, 1680s (N=C), 1258m, 1093m and 927m cm⁻¹; δ_{H} (200MHz; CDCl₃) 0.11 and 0.12 (6H, 2 x s, Si(CH₃)₂), 0.91 (9H, s, SiC(CH₃)₃), 1.25 (3H, d, *J* 6.5Hz, CHCH₃), 2.52 (1H, s, OH), 3.68 (1H, t, *J* 2.5Hz, 1 x CHCH), 3.89 (1H, t, *J* 2.5Hz, 1 x CHCH), 3.92 (1H, q, *J* 6.5Hz, CH(CH₃)) and 5.39 (1H, t, *J* 2.5Hz, CHC(NCBr₂)).

1 α -(1'-*t*-Butyldimethylsilyloxyethyl)-4 β , 5 β -epoxy-2 α , 3 α -epoxy-3-isocyanocyclopentan-1 β -ol (410)

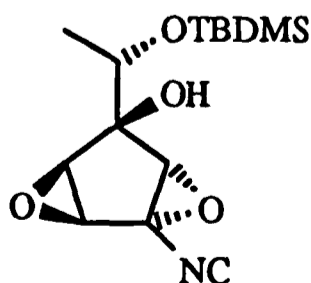

Method 1

To a stirred solution of 1α -(1'-*t*-butyldimethylsilyloxyethyl)- 2β , 3β -epoxy-4-en-4-dibromoiminocyclopentan- 1β -ol (**408**) (50mg, 0.11mmol.) in anhydrous dichloromethane (1ml) under an inert atmosphere of argon was added propylene oxide (84 μ l, 1.1mmol.) followed by methyl(trifluoromethyl)dioxirane (*ca.* 0.5M solution in 1,1,1-trifluoroacetone) in batches of *ca.* 100 μ l until t.l.c analysis indicated complete consumption of starting material. The mixture was then concentrated *in vacuo*. To a stirred solution of the residue in anhydrous dichloromethane (1ml) was added triethylphosphite (194 μ l, 1.1mmol.). The mixture was stirred at room temperature for one hour before being concentrated *in vacuo* to yield a brown oil. Flash chromatography (SiO₂, P.E. 30-40:ether; 85:15) afforded 1α -(1'-*t*-butyldimethylsilyloxyethyl)- 4β , 5β -epoxy- 2α , 3α -epoxy-3-isocyanocyclopentan- 1β -ol (**410**) as a pale yellow oil (6mg, 18%), (*R*_f 0.3, P.E. 30-40: ether 85: 15); *m/z* (high resolution) Found 298.1474, C₁₄H₂₃NO₄Si+H⁺ requires 298.1474; ν_{\max} (FT IR, CDCl₃ solution, NaCl plates) 3694m (OH), 2957m, 2932m, 2899m, 2859m, 2137s (NC), 1602s, 1471m, 1463m, 1379m, 1363m, 1260s, 1176m, 1096m, 1021m and 927m cm⁻¹; δ_{H} (500MHz; CDCl₃) 0.11 and 0.14 (6H, 2 x s, Si(CH₃)₂), 0.92 (9H, s, SiC(CH₃)₃), 1.29 (3H, d, *J* 6.5Hz, CHCH₃), 2.87 (1H, s, OH), 3.32 (1H, dd, *J* 2Hz, *J* 2.5Hz, C(OH)CHC(NC)), 3.52 (1H, dd, *J* 1.5Hz, *J* 2Hz, C(OH)CHCH), 3.82 (1H, q, *J* 6.5Hz, CH(OH)) and 4.04 (1H, dd, *J* 1.5Hz, *J* 2.5Hz, C(OH)CHCH); δ_{C} (50MHz; CDCl₃) -4.83 and -4.03 (Si(CH₃)₂), 17.41 (CHCH₃), 17.94 (SiC(CH₃)₃), 25.73 (SiC(CH₃)₃), 54.99, 58.80 and 60.37 (C(OH)CHCH and C(OH)CHC(NC)), 59.95 (C(NC)), 77.00 (CHCH₃), 82.37 (C(OH)) and 167.46 (C(NC)); *m/z* (desorption chemical ionisation, NH₃) 315[MNH₄⁺, 45%], 298[MH⁺, 25], 159[100], 132[59], 91[71] and 74[60].

Method 2

To a stirred solution of 1α -(1'-*t*-butyldimethylsilyloxyethyl)- 2β , 3β -epoxy-4-en-4-dibromoimino-cyclopentan- 1β -ol (**408**) (55mg, 0.12mmol.) in anhydrous dichloromethane (1ml) under an inert atmosphere of argon was added propylene oxide (87 μ l, 1.2mmol.) followed by methyl(trifluoromethyl)dioxirane (*ca.* 0.5M solution in 1,1,1-trifluoroacetone) in

batches of *ca.* 100 μ l until *ca.* t.l.c analysis indicated complete consumption of starting material. The mixture was then concentrated *in vacuo*. To a stirred solution of the residue in anhydrous benzene (2ml) under an inert atmosphere of argon and cooled to 0 $^{\circ}$ C was added propylene oxide (87 μ l, 1.2mmol.) followed by triphenyltinhydride (153 μ l, 0.60mmol.) and AIBN (*ca.* 4mg). The mixture was then stirred at 0 $^{\circ}$ C whilst being irradiated with a 250W bulb for 1 hour before being concentrated *in vacuo* to yield a yellow oil. Flash chromatography (SiO₂, P.E. 30-40:ether; 85:15) afforded 1 α -(1'-*t*-butyldimethylsilyloxyethyl)-4 β , 5 β -epoxy-2 α , 3 α -epoxy-3-isocyano-cyclopentan-1 β -ol (410) as a pale yellow oil (6mg, 16%). Spectroscopic data were identical to those obtained for (410) prepared by method 1 above.

1 α -(1'-Hydroxy)-4 β , 5 β -epoxy-2 α , 3 α -epoxy-3-isocyano-cyclopentan-1 β -ol ((\pm)-trichoviridin) (16)

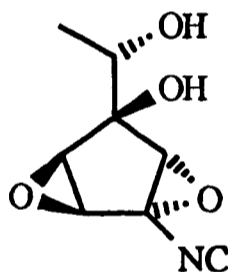

To a stirred solution of 1 α -(1'-*t*-butyldimethylsilyloxyethyl)-4 β , 5 β -epoxy-2 α , 3 α -epoxy-3-isocyanocyclopentan-1 β -ol (410) (6mg, 0.020mmol.) in anhydrous THF (0.5ml) under an inert atmosphere of argon cooled to 0 $^{\circ}$ C was added TBAF (23 μ l of a 0.1M solution in THF, 0.023mmol.). The mixture was stirred for 10 minutes before being filtered through a plug of silica (eluting with THF) and concentrated *in vacuo* to yield a yellow oil. Flash chromatography (SiO₂, dichloromethane:THF; 90:10) afforded 1 α -(1'-hydroxy)-4 β , 5 β -epoxy-2 α , 3 α -epoxy-3-isocyano-cyclopentan-1 β -ol ((\pm)-trichoviridin) (16)^{28, 29} as a white crystalline solid (2.5mg, 68%), (R_f 0.3, dichloromethane:THF; 90:10); m/z (high resolution) Found 184.061, C₈H₉NO₄+H⁺ requires 184.061; ν_{\max} (FT IR, CDCl₃ solution, NaCl plates) 3691m and 3569m (OH), 2931m, 2856m, 2136s (NC), 1602m, 1398m, 1185m, 1134m, 1094m, 1079m, 1015m, 998m, 960m and 928m and 831m cm⁻¹; δ_{H} (500MHz;

CDCl₃) 1.36 (3H, d, *J* 6.5Hz, CHCH₃), 2.07 (1H, d, *J* 10Hz, CH(OH)), 2.62 (1H, d, *J* 1Hz, C(OH)CH(OH)), 3.50 (1H, dd, *J* 1Hz, *J* 2Hz, C(OH)CHC(NC)), 3.64 (1H, dd, *J* 2Hz, *J* 2.5Hz, C(OH)CHCH), 3.77 (1H, ddq, *J* 1Hz, *J* 10Hz, *J* 6.5Hz, CH(OH)) and 4.12 (1H, dd, *J* 1Hz, *J* 2.5Hz, C(OH)CHCH); *m/z* (desorption chemical ionisation, NH₃) 201[MNH₄⁺, 95%], 184[MH⁺, 100], 168[66] and 112[81].

1-(2',4'-Dinitrophenylsulfenylchloroimino)-4-*t*-butyl cyclohexene (399)

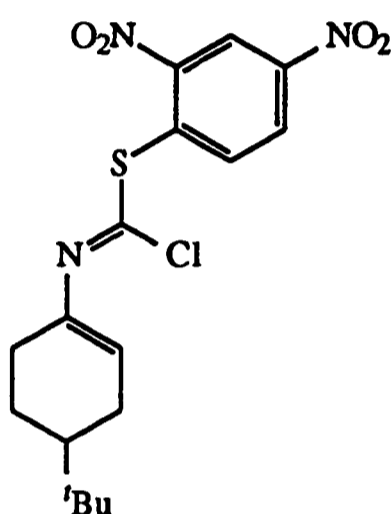

To a stirred solution of 1-isocyano-4-*t*-butylcyclohexene (383) (14mg, 0.086mmol.) in anhydrous dichloromethane (1ml) under an inert atmosphere of argon at -40°C was added propylene oxide (301μl, 4.29mmol.) followed by 2,4-dinitrosulfenylchloride (20mg, 0.086mmol.). The mixture was allowed to warm to room temperature and stirred at room temperature for one hour before being concentrated *in vacuo* to yield a yellow oil. Flash chromatography (SiO₂, P.E. 30-40:ether; 60:40) afforded 1-(2',4'-dinitrophenylsulfenylchloroimino)-4-*t*-butyl cyclohexene (399) (33mg, 96%) as a yellow oil, (*R_f* 0.4, P.E 30-40:ether 60:40); *v*_{max} (FT IR, CDCl₃ solution, NaCl plates) 2960m, 2865m, 2351m, 1640s (N=C), 1595s, 1535s (NO₂), 1345s (NO₂) and 927m cm⁻¹; *δ*_H (200MHz; CDCl₃) 0.91 (9H, s, C(CH₃)₃), 1.18-2.40 (7H, m, (CH₂)₂CH(*t*Bu)CH₂), 5.18-5.28 (1H, m, CH=C), 8.26 (1H, d, *J* 9Hz, CHCHC(NO₂)), 8.46 (1H, dd, *J* 2.5Hz *J* 9Hz, CHCHC(NO₂)) and 8.93 (1H, d, *J* 2.5Hz, C(NO₂)CHC(NO₂)); *m/z* (desorption chemical ionisation, NH₃) 364[(M-Cl)⁺, 10%], 165[20] and 139[100].

1 α -(1'-*t*-Butyldimethylsilyloxyethyl)-2 β , 3 β -epoxy-4-en-4-(2'',4''-dinitrophenylsulfenylchloro imino)-cyclopentan-1 β -ol (400)

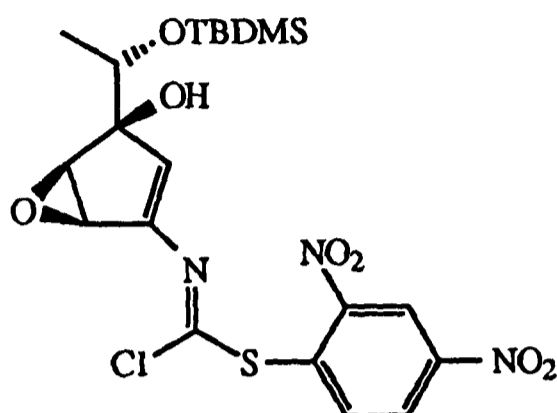

To a stirred solution of 1 α -(1'-*t*-butyldimethylsilyloxyethyl)-2 β , 3 β -epoxy-4-en-4-isocyanocyclopentan-1 β -ol (325) (9mg, 0.032mmol.) in anhydrous dichloromethane (1ml) under an inert atmosphere of argon at -40°C was added propylene oxide (112 μ l, 1.6mmol.) followed by 2,4-dinitrosulfenylchloride (7.5mg, 0.032mmol.). The mixture was allowed to warm to room temperature and stirred at room temperature for ninety minutes before being concentrated *in vacuo* to yield a yellow oil. Flash chromatography (SiO₂, P.E. 30-40:ether; 70:30) afforded 1 α -(1'-*t*-butyldimethylsilyloxyethyl)-2 β , 3 β -epoxy-4-en-4-(2'',4''-dinitrophenylsulfenylchloroimino)-cyclopentan-1 β -ol (400) (16mg, 97%) as a yellow oil, (R_f 0.4, P.E 30-40:ether 70:30); ν_{\max} (FT IR, Thin film, NaCl plates) 2932m, 2859m, 2349m, 1641s (N=C), 1598s, 1537s (NO₂), 1346s (NO₂), 1258m and 1093m cm⁻¹; δ_{H} (200MHz; CDCl₃) 0.10 and 0.12 (6H, 2 x s, Si(CH₃)₂), 0.90 (9H, s, SiC(CH₃)₃), 1.25 (3H, d, *J* 6.5Hz, CHCH₃), 2.51 (1H, s, OH), 3.68 (1H, t, *J* 2.5Hz, 1 x CHCH), 3.82 (1H, t, *J* 2.5Hz, 1 x CHCH), 3.91 (1H, q, *J* 6.5Hz, CH(CH₃)), 5.31 (1H, t, *J* 2.5Hz, CHC(NC)), 8.20 (1H, d, *J* 9Hz CHCHC(NO₂)), 8.61 (1H, dd, *J* 2.5Hz, *J* 8Hz, CHCHC(NO₂)) and 8.91 (1H, d, *J* 2.5Hz, C(NO₂)CHC(NO₂)); *m/z* (desorption chemical ionisation, NH₃) 480 [(M-Cl)⁺, 15%], 298[45], 282[30], 254[30], 159[49], 141[100], 109[80] and 91[72].

6.2.3 Studies Towards the Mechanism of the Thiooxime Rearrangement

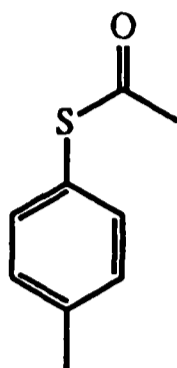
p-Tolylthioacetate (429)

A stirred mixture of thiocresol (10.1g, 0.08mmol.) and acetic anhydride (40ml) was refluxed for eight hours before being concentrated *in vacuo*. The residue was dissolved in dichloromethane (100ml), washed with H₂O (2 x 30ml), dried (Na₂SO₄), filtered and concentrated *in vacuo* to yield a pale yellow oil. Distillation under reduced pressure afforded *p*-tolylthioacetate (429) as a colourless oil (12.2g, 90%), (b.p. 75°C (1mmHg), (R_f 0.8, P.E 30-40:ether 20:80); ν_{\max} (FT IR, Thin film, NaCl plates) 3025m, 2923m, 1826m, 1708s (C=O), 1599m, 1494s, 1426m, 1367m, 1353m, 1119m and 809m cm⁻¹; δ_{H} (200MHz; CDCl₃) 2.39 and 2.42 (2 x 3H, 2 x s, C(O)CH₃ and (C₆H₄)CH₃) and 7.24 and 7.32 (2 x 2H, dd, *J* 8Hz, (C₆H₄)CH₃); δ_{C} (50MHz; CDCl₃) 21.32 and 30.06 (C(O)CH₃ and (C₆H₄)CH₃), 130.03 and 134.43 (aromatic CH), 124.47 and 139.68 (2 x aromatic *ipso* C) and 194.49 (C(O)CH₃); *m/z* (GCMS, electron impact) 166[MH⁺, 21], 124[100] and 91[72].

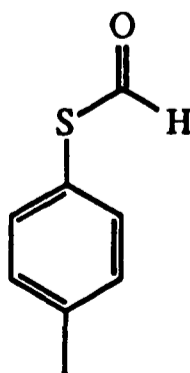
p-Tolylthioformate (433)

To a stirred solution of *p*-thiocresol (10.5g, 0.08mol.) in formic acid (9.6ml, 0.25mol.) and acetic anhydride (14.0ml, 0.13mol.) was added pyridine (136 μ l, 1.69mmol). The mixture was stirred at room temperature for ninety six hours before being concentrated *in vacuo*. The residue was dissolved in dichloromethane (100ml), washed with H₂O (2 x 30ml), dried (Na₂SO₄), filtered and concentrated *in vacuo* to yield a pale yellow oil. Distillation under reduced pressure afforded *p*-tolylthioformate (433) as a colourless oil (10.9g, 85%), (b.p. 80°C (1mmHg), (R_f 0.8, P.E 30-40:ether 20:80); ν_{\max} (FT IR, Thin film, NaCl plates) 3026m, 2922m, 2822m, 1680s (C=O), 1599m, 1493m, 1341m and 813m cm⁻¹; δ_{H} (200MHz; CDCl₃) 2.41 (3H, s, (C₆H₄)CH₃), 7.27 and 7.68 (2 x 2H, dd, *J* 8Hz, (C₆H₄)CH₃) and 10.23 (1H, s, C(O)H); δ_{C} (50MHz; CDCl₃) 21.22 ((C₆H₄)CH₃), 130.04 and 134.20 (aromatic CH), 122.61 and 140.30 (2 x aromatic *ipso* C) and 190.54 (C(O)H); *m/z* (GCMS, electron impact) 152[M⁺, 23%], 124[72] and 91[100].

Chapter 7

References for Part I

1. M.S. Edenborough and R.B. Herbert, *Nat. Prod. Rep.*, 1988, 229.
2. W. Rothe, *Pharmazie*, 1950, 5, 190.
3. N. Kaniss, *Pharmazie*, 1954, 9, 203.
4. F. Freude and N. Kaniss, *Pharmazie*, 1954, 9, 198.
5. I. Hagedorn and H. Tönjes, *Pharmazie*, 1956, 11, 409.
6. I. Hagedorn and H. Tönjes, *Pharmazie*, 1957, 12, 567.
7. D. Britton, W.B. Gleason and M. Glick, *Cryst. Struct. Commun.*, 1981, 10, 1497.
8. H. Achenbach, H. Strittmatter and W. Kohl, *Chem. Ber.*, 1972, 105, 3061.
9. A. Takatsuki, S. Suzuki, K. Ando, G. Tamura and K. Arima, *J. Antibiot.*, 1968, 21, 671.
10. A. Takatsuki, G. Tamura and K. Arima, *J. Antibiot.*, 1968, 21, 676.
11. I. Hagedorn, U. Eholzer and H. Etling, *Chem. Ber.*, 1965, 98, 193.
12. I. Hagedorn and U. Eholzer, *Chem. Ber.*, 1965, 98, 202.
13. I. Hagedorn and U. Eholzer, *Angew. Chem. Int. Ed. Engl.*, 1962, 1, 212.
14. K. Ando, S. Suzuki, A. Takatsuki, K. Arima and G. Tamura, *J. Antibiot.*, 1968, 21, 582.
15. K. Ando, G. Tamura and K. Arima, *J. Antibiot.*, 1968, 21, 587.
16. N. Kitahara and A. Endo, *J. Antibiot.*, 1981, 34, 1556.
17. M. Tsunakawa, N. Ohkusa, S. Kobaru, Y. Narita, S. Murata, Y. Sawada and T. Oki, *J. Antibiot.*, 1993, 46, 687.
18. J. Itoh, Y. Takeuchi, S. Gomi, S. Inouye, T. Mikawa, N. Yoshikawa and H. Ohkishi, *J. Antibiot.*, 1990, 43, 456.
19. C. Takahashi, S. Sekita, K. Yoshihira and S. Natori, *Chem. Pharm. Bull.*, 1976, 24, 2317.
20. W. Rothe, *Dtsch. Med. Wschr.*, 1954, 79, 1080.

21. W. Rothe, H. Sous, H. Keller and H. Mückter, *Antibiotics Annual*, Medical Encyclopedia Inc., New York, 1956-1957, p.140.
22. R. Beiersdorf and W. Ahrens, *Pharmazie*, 1953, **8**, 796.
23. E.L. Ghisalberti and K. Sivasithamparam, *Soil Biol. Biochem.*, 1991, **23**, 1011.
24. D. Brewer, E.J. Gabe, A.W. Hanson, A. Taylor, J.W. Keeping, V. Thaller and B.C. Das, *J. Chem. Soc., Chem. Commun.*, 1979, 1061.
25. A. Fujiwara, T. Okuda, S. Masuda, Y. Shiomi, C. Miyamoto, Y. Sekine, M. Tazoe and M. Fujiwara, *Agric. Biol. Chem.*, 1982, **46**, 1803.
26. T. Yamano, S. Hemmi, I. Yamamoto and K. Tsubaki, Jpn. Kokai 45-15435 (1970).
27. A. Tamura, H. Kotani and S. Naruto, *J. Antibiot.*, 1975, **28**, 161.
28. M. Nobuhara, H. Tazima, K. Shudo, A. Itai, T. Okamoto and Y. Iitaka, *Chem. Pharm. Bull.*, 1976, **24**, 832.
29. W.D. Ollis, M. Rey, W.O. Godtfredsen, N. Rastrup-Andersen, S. Vangedal and T.J. King, *Tetrahedron*, 1980, **36**, 515.
30. M. Fujiwara, A. Fujiwara and T. Okuda, Jpn. Kokai 53-26395 (1978).
31. M. Fujiwara, A. Fujiwara and T. Okuda, Jpn. Kokai 53-15345 (1978).
32. D. Brewer, F.W. Calder, T.M. MacIntyre and A. Taylor, *J. Agric. Sci.*, 1971, **76**, 465.
33. D. Brewer and A. Taylor, *Proc. N. S. Inst. Sci.*, 1980, **30**, 101.
34. D. Brewer, A. Taylor and M.M. Hoehn, *J. Agric. Sci.*, 1972, **78**, 257.
35. D. Brewer, A. Feicht, A. Taylor, J.W. Keeping, A.A. Taha and V. Thaller, *Can. J. Microbiol.*, 1982, **28**, 1252.
36. S.N. Liss, D. Brewer, A. Taylor and G.A. Jones, *Can. J. Microbiol.*, 1985, **31**, 767.
37. B.S. Crandall and G.F. Gravatt, *Ceiba*, 1967, **13**, 43.
38. A.W. Hanson, A.J. McAlees and A. Taylor, *J. Chem Soc., Perkin I*, 1985, 441.
39. R.K. Boyd, A.J. McAlees, A. Taylor and J.A. Walter, *J. Chem Soc., Perkin I*, 1991, 1461.
40. L.D. Boeck, M.M. Hoehn, T.H. Sands and R.W. Wetzel, *J. Antibiot.*, 1978, **31**, 19.
41. J.B. Gloer, G.K. Poch, D.M. Short and D.V. McCloskey, *J. Org. Chem.*, 1988, **53**, 3758.
42. H. Achenbach and H. Grisebach, *Z. Naturforsch., Teil B*, 1965, **20**, 137.

43. R.B. Herbert and J. Mann, *J. Chem. Soc., Chem. Commun.*, 1984, 1474.
44. K.M. Cable, R.B. Herbert, A.R. Knaggs and J. Mann, *J. Chem. Soc., Perkin I*, 1991, 595.
45. K.M. Cable, R.B. Herbert and J. Mann, *Tetrahedron Lett.*, 1987, **28**, 3159.
46. H. Grisebach and F. König, *Chem. Ber.*, 1972, **105**, 784.
47. J.E. Baldwin, A.E. Derome, L.D. Field, P.T. Gallagher, A.A. Taha, V. Thaller, D. Brewer and A. Taylor, *J. Chem. Soc., Chem. Commun.*, 1981, 1227.
48. J.E. Baldwin, H.S. Bansal, J. Chondrogianni, L.D. Field, A.A. Taha, V. Thaller, D. Brewer and A. Taylor, *Tetrahedron*, 1985, **41**, 1931.
49. R.J. Parry and H.P. Buu, *Tetrahedron Lett.*, 1982, **23**, 1435.
50. R.B. Herbert, *The Biosynthesis of Secondary Metabolites*, Chapman and Hall, London, 1989.
51. H.S. Bansal, D. Phil. Thesis, University of Oxford, 1984.
52. F. Cafieri, E. Fattorusso, S. Magno, C. Santacroce and D. Sica, *Tetrahedron*, 1973, **29**, 4259.
53. M. Adinolfi, L. De Napoli, B. Di Blasio, A. Iengo, C. Pedone and C. Santacroce, *Tetrahedron Lett.*, 1977, 2815.
54. C.W.J. Chang and P.J. Scheuer, *Top. Curr. Chem.*, 1993, **167**, 33.
55. P.J. Scheuer, *Acc. Chem. Res.*, 1992, **25**, 433.
56. P.J. Scheuer, *Science*, 1990, **248**, 173.
57. B.J. Burreson, P.J. Scheuer, J. Finer and J. Clardy, *J. Am. Chem. Soc.*, 1975, **97**, 4763.
58. N. Fusetani, H.J. Wolstenholme, K. Shinoda, N. Asai, S. Matsunaga, H. Onuki and H. Hirota, *Tetrahedron Lett.*, 1992, **33**, 6823.
59. L. Minale, R. Riccio and G. Sodano, *Tetrahedron*, 1974, **30**, 1341.
60. B. Di Blasio, E. Fattorusso, S. Magno, L. Mayol, C. Pedone, C. Santacroce and D. Sica, *Tetrahedron*, 1976, **32**, 473.
61. E. Fattorusso, S. Magno, L. Mayol, C. Santacroce and D. Sica, *Tetrahedron*, 1974, **30**, 3911.
62. P. Ciminiello, E. Fattorusso, S. Magno and L. Mayol, *J. Nat. Prod.*, 1985, **48**, 64.

63. N.K. Gulavita, E.D. de Silva, M.R. Hagadone, P. Karuso, P.J. Scheuer, G.D. Van Duyne and J. Clardy, *J. Org. Chem.*, 1986, **51**, 5136.
64. B.J. Burreson, C. Christophersen and P.J. Scheuer, *Tetrahedron*, 1975, **31**, 2015.
65. B.J. Burreson and P.J. Scheuer, *J. Chem. Soc., Chem. Commun.*, 1974, 1035.
66. J.T. Baker, R.J. Wells, W.E. Oberhänsli and G.B. Hawes, *J. Am. Chem. Soc.*, 1976, **98**, 4010.
67. N. Fusetani, K. Yasumuro, H. Kawai, T. Natori, L. Brinen and J. Clardy, *Tetrahedron Lett.*, 1990, **31**, 3599.
68. D.S. Bhakuni and S. Jain, *J. Sci. Ind. Res.*, 1990, **49**, 330.
69. J.H. Cardellina II, *Pure Appl. Chem.*, 1986, **58**, 365.
70. M.T. Hamann and P.J. Scheuer, *Tetrahedron Lett.*, 1991, **32**, 5671.
71. K.A. Alvi, L. Tenenbaum and P. Crews, *J. Nat. Prod.*, 1991, **54**, 71.
72. C.K. Angerhofer, J.M. Pezzuto, G.M. König, A.D. Wright and O. Sticher, *J. Nat. Prod.*, 1992, **55**, 1787.
73. A. Iengo, C. Santacroce and G. Sodano, *Experientia*, 1979, **35**, 10.
74. M.R. Hagadone, P.J. Scheuer and A. Hohm, *J. Am. Chem. Soc.*, 1984, **106**, 2447.
75. S.J. Wratten and D.J. Faulkner, *J. Am. Chem. Soc.*, 1977, **99**, 7367.
76. S.J. Wratten, D.J. Faulkner, D. Van Engen and J. Clardy, *Tetrahedron Lett.*, 1978, 1391.
77. S.J. Wratten and D.J. Faulkner, *Tetrahedron Lett.*, 1978, 1395.
78. M.J. Garson, *Chem. Rev.*, 1993, **93**, 1699.
79. P. Karuso and P.J. Scheuer, *J. Org. Chem.*, 1989, **54**, 2092.
80. M.J. Garson, *J. Chem. Soc., Chem. Commun.*, 1986, 35.
81. C.J.R. Fookes, M.J. Garson, J.K. MacLeod, B.W. Skelton and A.H. White, *J. Chem. Soc., Perkin I*, 1988, 1003.
82. C.W.J. Chang and P.J. Scheuer, *J. Comp. Biochem. Physiol.*, 1990, **97B**, 227.
83. P. Karuso, A. Poiner and P.J. Scheuer, *J. Org. Chem.*, 1989, **54**, 2095.
84. S. Omar, C. Albert, T. Fanni and P. Crews, *J. Org. Chem.*, 1988, **53**, 5971.
85. C.W.J. Chang, A. Patra, J.A. Baker and P.J. Scheuer, *J. Am. Chem. Soc.*, 1987, **109**, 6119.

86. C.W.J. Chang, A. Patra, D.M. Roll, P.J. Scheuer, G.K. Matsumoto and J. Clardy, *J. Am. Chem. Soc.*, 1984, **106**, 4644.
87. A. Patra, C.W.J. Chang, P.J. Scheuer, G.D. Van Duyne, G.K. Matsumoto and J. Clardy, *J. Am. Chem. Soc.*, 1984, **106**, 7981.
88. R.E. Moore, C. Cheuk and G.M.L. Patterson, *J. Am. Chem. Soc.*, 1984, **106**, 6456.
89. R.E. Moore, C. Cheuk, X.-Q.G. Yang, G.M.L. Patterson, R. Bonjouklian, T.A. Smitka, J.S. Mynderse, R.S. Foster, N.D. Jones, J.K. Swartzendruber and J.B. Deeter, *J. Org. Chem.*, 1987, **52**, 1036.
90. R.E. Moore, X.-Q.G. Yang, G.M.L. Patterson, R. Bonjouklian and T.A. Smitka, *Tetrahedron*, 1989, **28**, 1565.
91. T.A. Smitka, R. Bonjouklian, L. Doolin, N.D. Jones, J.B. Deeter, W.Y. Yoshida, M.R. Prinsep, R.E. Moore and G.M.L. Patterson, *J. Org. Chem.*, 1992, **57**, 857.
92. A. Park, R.E. Moore and G.M.L. Patterson, *Tetrahedron Lett.*, 1992, **33**, 3257.
93. S. Carmeli, R.E. Moore, G.M.L. Patterson, Y. Mori and M. Suzuki, *J. Org. Chem.*, 1990, **55**, 4431.
94. V. Bornemann, G.M.L. Patterson and R.E. Moore, *J. Am. Chem. Soc.*, 1988, **110**, 2339.
95. M. Nazly, P.A. Collins, C.J. Knowles, B. Vennesland, E.E. Conn, J. Westley and F. Wissing, *Cyanide in Biology*, Academic Press, London, 1981, p.289-300.
96. P.A. Castric, *Cyanide in Biology*, Academic Press, London, 1981, p.233-261.
97. J. Mann, *Secondary Metabolism*, Clarendon Press, Oxford, 1987.
98. J.A. Marquez, A.C. Horan, M. Kalyanpur, B.K. Lee, D. Loebenberg, G.H. Miller, M. Patel and J.A. Waitz, *J. Antibiot.*, 1983, **36**, 1101.
99. J.J.K. Wright, A.B. Cooper, A.T. McPhail, Y. Merrill, T.L. Nagabhushan and M.S. Puar, *J. Chem. Soc., Chem. Commun.*, 1982, 1188.
100. K. Isshiki, Y. Takahashi, M. Okada, T. Sawa, M. Hamada, H. Naganawa, T. Takita, T. Takeuchi, H. Umezawa, M. Yamamoto and K. Tatsuta, *J. Antibiot.*, 1987, **40**, 1195.
101. M.S. Puar, H. Munayyer, V. Hedge, B.K. Lee and J.A. Waitz, *J. Antibiot.*, 1985, **38**, 530.

102. W.L. Parker, M.L. Rathnum, J.H. Johnson, J.S. Wells, P.A. Principe and R.B. Sykes, *J. Antibiot.*, 1988, **41**, 454.
103. P.D. Singh, W.-C. Liu, J.Z. Gougoutas, M.F. Malley, M.A. Porubcan, W.H. Trejo, J.S. Wells and R.B. Sykes, *J. Antibiot.*, 1988, **41**, 446.
104. J.R. Evans, E.J. Napier and P. Yates, *J. Antibiot.*, 1976, **29**, 850.
105. I. Hoppe and U. Schöllkopf, *Liebigs Ann. Chem.*, 1984, 600.
106. C.J. Knowles, *Bacteriological Rev.*, 1976, **40**, 652.
107. J.P. Ferris, *The Chemistry of Functional Groups Supplement C*, John Wiley and Sons Ltd., New York, 1983, p.325.
108. M.J. Garson, V. Partali, S. Liaaen-Jensen and I.L. Stoilov, *J. Comp. Biochem. Physiol.*, 1988, **91B**, 293.
109. C.R. Wilkinson and R. Garrone, *Nutrition in the Lower Metazoa*, Pergamon Press, Oxford, 1980, p.157-161.
110. W. Lieke, *Ann. Chem. Pharm.*, 1859, **112**, 316.
111. A.W. Hofmann, *Liebigs Ann. Chem.*, 1867, **144**, 114.
112. A. Gautier, *Ann. Chim. (Paris)*, 1869, *Ser. 4*, 1869.
113. I. Ugi, *Angew. Chem. Int. Ed. Engl.*, 1962, **1**, 8.
114. H. Brederick, B. Föhlich and K. Walz, *Liebigs Ann. Chem.*, 1965, **688**, 93.
115. E. Oliveri-Mandala and B. Alagna, *Gazz. Chim. Ital.*, 1910, **40**, **Part 2**, 441.
116. D.S. Kemp and R.B. Woodward, *Tetrahedron*, 1965, **21**, 3019.
117. N. Kreutzkamp and K. Lammerhirt, *Angew. Chem. Int. Ed. Engl.*, 1968, **7**, 372.
118. H. Aigner, G. Koch and D. Marquarding, *Chem. Pept. Proteins, Proc. USSR-FRG Symp.*, 1980, 209.
119. U. Belluco, B. Crociani, R. Michelin and P. Ugualati, *Pure Appl. Chem.*, 1983, **55**, 47.
120. D.P. Plummer, *Diss. Abstr. Int. B*, 1983, **44**, 796.
121. E. Singleton and H.E. Oosthuizen, *Adv. Organomet. Chem.*, 1983, **2**, 209.
122. W.P. Fehlhammer, *Nachr. Chem., Tech. Lab.*, 1982, **30**, 187.
123. T. Fukuyama, X.Q. Chen. and G. Peng, *J. Am. Chem. Soc.*, 1994, **116**, 3127.
124. D.P. Curran and H. Liu, *J. Am. Chem. Soc.*, 1991, **113**, 2127.
125. Z.J. Witczak, *J. Carbohydr. Chem.*, 1984, **3**, 359.

126. C. Grundmann, *Methoden der Organischen Chemie (Hoeben-Weyl)*, Georg Thieme Verlag, Stuttgart, 1985, p.1611-1673.
127. H.M. Walborsky and M.P. Periasamy, *The Chemistry of Functional Groups, Supplement C*, John Wiley and Sons Ltd., New York, 1983, p.835.
128. I. Ugi (ed.), *Isonitrile Chemistry*, Academic Press, New York, 1971.
129. G. Giesmann, E. Von Hinrichs and I. Ugi, *J. Chem. Res. (S)*, 1982, 79.
130. J.E. Baldwin and I.A. O'Neil, *Synlett*, 1990, 603.
131. J.E. Baldwin, D.J. Aldous, C. Chan, L.M. Harwood, I.A. O'Neil and J.M. Peach, *Synlett*, 1989, 9.
132. E. Klein and G. Ohloff, *Tetrahedron*, 1963, 19, 1091.
133. T. Fukuyama and X.Q. Chen, *J. Am. Chem. Soc.*, 1994, 116, 3125.
134. S.J. Wratten, D.J. Faulkner, K. Hirotsu and J. Clardy, *Tetrahedron Lett.*, 1978, 4345.
135. E. Piers and M. Llinas-Brunet, *J. Org. Chem.*, 1989, 54, 1483.
136. E. Piers, M. Llinas-Brunet and R.M. Oballa, *Can. J. Chem.*, 1993, 71, 1484.
137. E. Piers and M.A. Romero, *Tetrahedron*, 1993, 49, 5791.
138. H. Nakamura, J. Kobayashi and Y. Ohizumi, *Tetrahedron Lett.*, 1984, 25, 5401.
139. Y. Ichikawa, *Synlett*, 1991, 715.
140. Y. Ichikawa, *J. Chem. Soc., Perkin I*, 1992, 2135.
141. Y. Ichikawa, M. Yamazaki and M. Isobe, *J. Chem. Soc., Perkin I*, 1993, 2429.
142. E. Piers, B.W.A. Yeung and S.J. Rettig, *Tetrahedron*, 1987, 43, 5521.
143. A.C. Guével and D.J. Hart, *Synlett*, 1994, 169.
144. D. Caine and H. Deutsch, *J. Am. Chem. Soc.*, 1978, 100, 8030.
145. H. Muratake and M. Natsume, *Tetrahedron*, 1990, 46, 6331.
146. E.J. Corey and M. Ishiguro, *Tetrahedron Lett.*, 1979, 30, 2745.
147. E.J. Corey, M. Behforouz and M. Ishiguro, *J. Am. Chem. Soc.*, 1979, 101, 1608.
148. H. Yamamoto and H.L. Sham, *J. Am. Chem. Soc.*, 1979, 101, 1609.
149. D.H.R. Barton, T. Bowles, S. Husinec, J.E. Forbes, A. Llobera, A.E.A. Porter and S.Z. Zard, *Tetrahedron Lett.*, 1988, 29, 3343.
150. J.E. McMurry and J. Melton, *J. Org. Chem.*, 1973, 38, 4367.
151. D.H.R. Barton, Personal Communication.
152. J.E. Baldwin, D.J. Aldous and I.A. O'Neil, *Tetrahedron Lett.*, 1990, 31, 2051.

153. T. Morimoto, Y. Nezu, K. Achiwa and M.J. Sekiya, *J. Chem. Soc., Chem. Commun.*, 1985, 1584.
154. E.M. Gordon and J. Pluscec, *J. Org. Chem.*, 1979, **44**, 1218.
155. A.G.M. Barrett, H. Kwon and E.M. Wallace, *J. Chem. Soc., Chem. Commun.*, 1993, 1760.
156. U. Schöllkopf, F. Gerhart and R. Schröder, *Angew. Chem. Int. Ed. Engl.*, 1969, **8**, 672.
157. M. Suzuki, K.-I. Nunami, K. Matsumoto, N. Yoneda, O. Kasuga, H. Yoshida and T. Yamaguchi, *Chem. Pharm. Bull.*, 1980, **28**, 2374.
158. A.S. Kende, K.M.J. Brands and B. Blass, *Tetrahedron Lett.*, 1993, **34**, 579.
159. H. Umezawa, M. Imoto, T. Sawa, K. Isshiki, N. Matsuda, T. Uchida, H. Inuma, M. Hamada and T. Takeuchi, *J. Antibiot.*, 1986, **39**, 170.
160. H. Nakamura, Y. Iitaka, M. Imoto, K. Isshiki, H. Naganawa, T. Takeuchi and H. Umezawa, *J. Antibiot.*, 1986, **39**, 314.
161. J. Kleinschroth and J. Hartenstein, *Synthesis*, 1988, 970.
162. J.E. Baldwin, D.R. Kelly and C.B. Ziegler, *J. Chem. Soc., Chem. Commun.*, 1984, 133.
163. J. Chondrogianni, D. Phil. Thesis, University of Oxford, 1985.
164. A. Iengo, L. Mayol and C. Santacroce, *Experientia*, 1977, **33**, 11.
165. D.J. Hart and C.-S. Lai, *Synlett*, 1989, 49.
166. B. Chenera, C.-P. Chuang, D.J. Hart and C.-S. Lai, *J. Org. Chem.*, 1992, **57**, 2018.
167. T. Fukuyama and Y.M. Yung, *Tetrahedron Lett.*, 1981, **22**, 3759.
168. J.E. Baldwin, R.M. Adlington, J. Chondrogianni, M.S. Edenborough, J.W. Keeping and C.B. Ziegler, *J. Chem. Soc., Chem. Commun.*, 1985, 816.
169. K. Ohsugi, J. Ichida and E. Takahashi, Ger. Offen. 3326518 (1984).
170. I. Hoppe and U. Schöllkopf, *Liebigs. Ann. Chem.*, 1984, 608.
171. J.E. Baldwin and I.A. O'Neil, *Tetrahedron Lett.*, 1990, **31**, 2047.
172. A.R. Katritzky, L. Xie and W.-Q. Fan, *Synthesis*, 1993, 45.
173. M.T. Reetz, I. Chatziiosifidis, H. Künzer and H. Müller-Starke, *Tetrahedron*, 1983, **39**, 961.
174. T. Sasaki, A. Nakanishi and M. Ohno, *J. Org. Chem.*, 1981, **46**, 5445.

175. P.G. Gassman and T.L. Guggenheim, *J. Am. Chem. Soc.*, 1982, **104**, 5849.
176. G.O. Spessard, A.R. Ritter, D.M. Johnson and A.M. Montgomery, *Tetrahedron Lett.*, 1983, **24**, 655.
177. P.G. Gassman and R.S. Gremban, *Tetrahedron Lett.*, 1984, 3259.
178. J.G. Smith, *Synthesis*, 1984, 629.
179. P.G. Gassman and L.M. Haberman, *Tetrahedron Lett.*, 1985, **26**, 4971.
180. S.A. Carr and W.P. Weber, *Syn. Commun.*, 1985, **15**, 775.
181. P.G. Gassman and L.M. Haberman, *J. Org. Chem.*, 1986, **51**, 5010.
182. J. Yoshida, M. Itoh, Y. Morita and S. Isoe, *J. Chem. Soc., Chem. Commun.*, 1994, 549.
183. M.J. Garson, J.E. Thompson, R.M. Larsen, C.N. Battershill, P.T. Murphy and P.R. Bergquist, *Lipids*, 1992, **27**, 378.
184. E.J. Corey and P.A. Magriotis, *J. Am. Chem. Soc.*, 1987, **109**, 287.
185. E.J. Corey and X.-M. Cheng, *The Logic of Chemical Synthesis*, John Wiley and Sons Ltd., New York, 1989, p.218-220.
186. E. Kühle, B. Anders and G. Zumach, *Angew. Chem. Int. Ed. Engl.*, 1967, **6**, 649.
187. E. Kühle, *Angew. Chem. Int. Ed. Engl.*, 1969, **8**, 20.
188. A. Guirado, A. Zapata and M. Fenor, *Tetrahedron Lett.*, 1992, **33**, 4779.
189. T. Mukaiyama, H. Nambu and M. Okamoto, *J. Org. Chem.*, 1962, **27**, 3651.
190. J.E. Baldwin, J.C. Bottaro, P.D. Riordan and A.E. Derome, *J. Chem. Soc., Chem. Commun.*, 1982, 942.
191. J.E. Baldwin and Y. Yamaguchi, *Tetrahedron Lett.*, 1989, **30**, 3335.
192. T. Mukaiyama and Y. Yokota, *Bull. Chem. Soc. Jpn.*, 1965, **38**, 858.
193. A.W. Hofmann, *Ber. Dtsch. Chem. Ges.*, 1870, **3**, 766.
194. W. Weith, *Ber. Dtsch. Chem. Ges.*, 1873, **6**, 766.
195. D.H. Lorenz and E.I. Becker, *J. Org. Chem.*, 1963, **28**, 1707.
196. U. Schmidt and K.H. Kabitzke, *Angew. Chem. Int. Ed. Engl.*, 1964, **3**, 641.
197. D. Hoppe, *Angew. Chem. Int. Ed. Engl.*, 1974, **13**, 789.
198. U. Schöllkopf, *Angew. Chem. Int. Ed. Engl.*, 1977, **16**, 339.
199. B. Ledig, M. Marsch, K. Harms and G. Boche, *Angew. Chem. Int. Ed. Engl.*, 1992, **31**, 79.

200. S. Marcaccini and T. Torroba, *Org. Prep. Proc. Int.*, 1993, **25**, 141.
201. U. Schöllkopf and R. Schröder, *Tetrahedron Lett.*, 1973, 633.
202. M.J. Lombard, D. Phil. Thesis, University of Oxford, 1985.
203. G. Höfle, *Angew. Chem. Int. Ed. Engl.*, 1974, **13**, 676.
204. P. Boullanger, D. Marmet and G. Descotes, *Tetrahedron*, 1979, **35**, 163.
205. W.P. Weber and G.W. Gokel, *Tetrahedron Lett.*, 1972, 1637.
206. P. Jakobsen, *Acta. Chem. Scand.*, 1976, **B30**, 995.
207. G.C. Marconi, B.B. Molloy, R. Nagarajan, J.W. Martin, J.B. Deeter and J.L. Occolowitz, *J. Antibiot.*, 1978, **31**, 27.
208. J.R. Turner, T.F. Butler, R.S. Gordee and A.L. Thakkar, *J. Antibiot.*, 1978, **31**, 33.
209. *Science*, 1993, **260**, 1209-1396.
210. H.-H. Wüst, J. Bardenhagen and U. Schöllkopf, *Liebigs Ann. Chem.*, 1985, 1825.
211. U. Schöllkopf, D. Hoppe and R. Jentsch, *Chem. Ber.*, 1975, **108**, 1580.
212. E.M. Acton, M. Keyanpour-Rad, J.E. Christensen, H.H. Tong, R.P. Kwok and L. Goodman, *Carbohydrate Res.*, 1972, **22**, 477.
213. E.M. Gordon, H.W. Chang, C.M. Cimarusti, B. Toeplitz and J.Z. Gougoutas, *J. Am. Chem. Soc.*, 1980, **102**, 1690.
214. D.J. Aldous, D. Phil. Thesis, University of Oxford, 1987.
215. I.A. O'Neil, *Postdoctoral Report*, University of Oxford, 1989.
216. M.L. Smith, Part II Thesis, University of Oxford, 1991.
217. E.J. Corey and A. Venkateswarlu, *J. Am. Chem. Soc.*, 1972, **94**, 6190.
218. S. Hanessian and P. Lavalley, *Can. J. Chem.*, 1975, **53**, 2975.
219. B.H. Lipshutz and J.J. Pegram, *Tetrahedron Lett.*, 1980, **21**, 3343.
220. M.P. Edwards, S.V. Ley, S.G. Lister, B.D. Palmer and D.J. Williams, *J. Org. Chem.*, 1984, **49**, 3503.
221. R.J. Parry and F.-L. Lii, *J. Am. Chem. Soc.*, 1991, **113**, 4704.
222. J.K. Whitesell and D. Reynolds, *J. Org. Chem.*, 1983, **48**, 3548.
223. A. Akelah and D.C. Sherrington, *Chem. Rev.*, 1981, **81**, 557.
224. S.L. Regen and D.P. Lee, *J. Org. Chem.*, 1975, **40**, 1669.
225. W. Zhang and M.J. Robins, *Tetrahedron Lett.*, 1992, **33**, 1177.
226. G. Cardillo, M. Orena, S. Sandri and C. Tomasini, *Chem. Ind.*, 1983, 643.

227. D.A. Claremon and B.T. Phillips, *Tetrahedron Lett.*, 1988, **29**, 2155.
228. A.T. Russell, Unpublished results.
229. F. Campagna, A. Carotti and G. Casini, *Tetrahedron Lett.*, 1977, **21**, 1813.
230. T.R. Forbus and J.C. Martin, *J. Org. Chem.*, 1979, **44**, 313.
231. S.D. Young, C.T. Buse and C.H. Heathcock, *Organic Synthesis Coll. Vol. VII*, 1990, 381.
232. K. Mai and G. Patil, *J. Org. Chem.*, 1986, **51**, 3545.
233. D.T. Hurst and A.G. McInnes, *Can. J. Chem.*, 1965, **43**, 2004.
234. G.L. Bundy and D.C. Peterson, *Tetrahedron Lett.*, 1977, 41.
235. J.E. Baldwin, R.M. Adlington, A.T. Russell and M.L. Smith, *J. Chem. Soc., Chem. Commun.*, 1994, 85.
236. W.T. Haskins, R.M. Hann and C.S. Hudson, *J. Am. Chem. Soc.*, 1943, **65**, 1419.
237. A.E. Derome, D. Phil. Thesis, University of Oxford, 1982.
238. J.E. Baldwin, I.A. O'Neil and A.T. Russell, *Synlett*, 1991, 551.
239. J.I. McLoughlin and R.D. Little, *J. Org. Chem.*, 1988, **53**, 3624.
240. W.P. Hart, D.W. Macomber and M.D. Rausch, *J. Am. Chem. Soc.*, 1980, **102**, 1196.
241. R. Riemschneider and M. Kruger, *Monatsch. Chem.*, 1959, **90**, 573.
242. G. Grundke and H.M.R. Hoffmann, *J. Org. Chem.*, 1981, **46**, 5428.
243. E. Boyland and R. Nery, *J. Chem. Soc. C*, 1966, 354.
244. A.K. Qureshi and B. Sklarz, *J. Chem. Soc. C*, 1966, 412.
245. D.L. Boger and S.M. Weinreb, *Hetero-Diels-Alder Methodology*, Academic Press, New York, 1987.
246. S.M. Weinreb and R.B. Staib, *Tetrahedron*, 1982, **38**, 3087.
247. G.W. Kirby, *Chem. Soc. Rev.*, 1977, 1.
248. J.E. Baldwin, P.D. Bailey, G. Gallacher, K.A. Singleton and P.M. Wallace, *J. Chem. Soc., Chem. Commun.*, 1983, 1049.
249. H.C. Brown and W.C. Dickason, *J. Am. Chem. Soc.*, 1970, **92**, 709.
250. H.C. Brown and S. Krishnamurthy, *J. Am. Chem. Soc.*, 1972, **94**, 7159.
251. C.A. Brown, *J. Am. Chem. Soc.*, 1973, **95**, 4100.
252. G.E. Keck, S. Fleming, D. Nickell and P. Weider, *Syn. Commun.*, 1979, **9**, 281.

253. H.B. Henbest and J.J. McCullough, *Proc. Chem. Soc.*, 1962, 74.
254. K.B. Sharpless and T.R. Verhoeven, *Aldrichimica Acta*, 1979, 12, 74.
255. R.W. Murray, *Chem. Rev.*, 1989, 89, 1187.
256. W. Adam, R. Curci and J.O. Edwards, *Acc. Chem. Res.*, 1989, 22, 205.
257. W. Adam, J. Bialas and L. Hadjiarapoglou, *Chem. Ber.*, 1991, 124, 2377.
258. D. Grierson, *Organic Reactions*, John Wiley and Sons Ltd., New York, 1990, p.79.
259. A.L. Baumstark and P.C. Vasquez, *J. Org. Chem.*, 1988, 53, 3439.
260. G. Cicala, R. Curci, M. Fiorentino and O. Laricchiuta, *J. Org. Chem.*, 1982, 47, 2670.
261. M. Kurihara, S. Ito, N. Tsutsumi and N. Miyata, *Tetrahedron Lett.*, 1994, 35, 1577.
262. W. Adam, L. Hadjiarapoglou and B. Nestler, *Tetrahedron Lett.*, 1990, 31, 331.
263. W. Adam, L. Hadjiarapoglou and A. Smerz, *Chem. Ber.*, 1991, 124, 227.
264. R. Mello, M. Fiorentino, O. Sciacovelli and R. Curci, *J. Org. Chem.*, 1988, 53, 3890.
265. R. Mello, M. Fiorentino, C. Fusco and R. Curci, *J. Am. Chem. Soc.*, 1989, 111, 6749.
266. W. Adam, L. Hadjiarapoglou and X. Wang, *Tetrahedron Lett.*, 1989, 30, 6497.
267. R.W. Murray and R. Jeyaraman, *J. Org. Chem.*, 1985, 50, 2847.
268. L. Troisi, L. Cassidei, L. Lopez, R. Mello and R. Curci, *Tetrahedron Lett.*, 1989, 30, 257.
269. R. Mello, L. Cassidei, M. Fiorentino, C. Fusco, W. Hümmer, V. Jäger and R. Curci, *J. Am. Chem. Soc.*, 1991, 113, 2205.
270. W. Adam, E.-M. Peters, K. Peters, H.G. von Schnering and V. Voerckel, *Chem. Ber.*, 1992, 125, 1263.
271. A.G.M. Barrett, Personal Communication.
272. J. Gordon and R. Tabacchi, *J. Org. Chem.*, 1992, 57, 4728.
273. H.J. Lucas and E.R. Kennedy, *Organic Syntheses Collective Volume 3*, New York, John Wiley and Sons Ltd., 1955, p.482.
274. V.N.R. Pillai, *Synthesis*, 1980, 1.
275. D.H.R. Barton, T. Nakano and P.G. Sammes, *J. Chem. Soc. (C)*, 1968, 322.
276. D.H.R. Barton, Y.L. Chow, A. Cox and G.W. Kirby, *J. Chem. Soc.*, 1965, 3571.
277. R. Bossio, S. Marcaccini and R. Pepino, *Heterocycles*, 1986, 24, 2003.

278. A.J. Havlik and M.M. Wald, *J. Am. Chem. Soc.*, 1955, **77**, 5171.
279. I. Ugi and U. Fetzer, *Chem. Ber.*, 1961, **94**, 1116.
280. R.M. Adlington, J.E. Baldwin, A. Gansäuer, W. McCoull and A.T. Russell, *J. Chem. Soc., Perkin 1*, 1994, 1697.
281. Y. Ito and M. Murakami, *Synlett*, 1990, 245.
282. D. Chen, Unpublished results.
283. Commercially available from Fluka Chemical Company.
284. W.B. Motherwell and D. Crich, *Free Radical Chain Reactions in Organic Synthesis*, Academic Press, London, 1992, p.29-37 and 58-65.
285. T. Mukaiyama, M. Ueki, H. Maruyama and R. Matsueda, *J. Am. Chem. Soc.*, 1968, **90**, 4490.
286. G.M. Kosolapoff and L. Maier, *Organic Phosphorus Compounds*, Wiley-Interscience, New York, 1972.
- 287a. P. Strazzolini, A.G. Giumanini and S. Cauci, *Tetrahedron*, 1990, **46**, 1081; V. Gold and E.G. Jefferson, *J. Chem. Soc.*, 1953, 1416.
- 287b. G. Maas and B. Feith, *Angew. Chem. Int. Ed. Engl.*, 1985, **24**, 511.
288. R.W. Hofmann, *Chem. Rev.*, 1989, **89**, 1841.
289. M.B. Mitchell, D. Phil. Thesis, University of Oxford, 1993.
290. W.C. Still, M. Kahn and A. Mitra, *J. Org. Chem.*, 1978, **43**, 2923.
291. H.G. Kuivila and O.F. Beumel, *J. Am. Chem. Soc.*, 1961, **83**, 1246.
292. M. Fieser and L.F. Fieser, *Reagents for Organic Synthesis*, Wiley-Interscience, New York, 1969, p.10.
293. M. Fieser and L.F. Fieser, *Reagents for Organic Synthesis*, Wiley-Interscience, New York, 1975, p.523.
294. H. Ikehira and S. Tanimoto, *Synthesis*, 1983, 716.
295. R. Roeske, *J. Org. Chem.*, 1963, **28**, 1251.
296. J.A. Moore and D.E. Reed, *Organic Synthesis Collective Vol. 5*, John Wiley and Sons Inc., New York, 1973, p.351.

PART II

Chapter 8

Inhibitors of Angiotensin Converting Enzyme (ACE)**8.1 Introduction**

Humoral blood pressure is regulated by several complex mechanisms one of which is the renin-angiotensin-aldosterone system, Scheme 1.¹ Angiotensinogen (1), a circulating plasma α -globulin, produced by the liver, is hydrolysed by the proteolytic enzyme renin to the decapeptide, angiotensin I (2) which has little, if any, biological activity. Angiotensin-converting enzyme (or ACE, dipeptidyl carboxypeptidase I) then cleaves the C-terminal histidylleucine residue of angiotensin I (2), mainly in the lungs and blood vessels, to generate the octapeptide angiotensin II (3) which serves to increase blood pressure by two mechanisms. Firstly angiotensin II (3) acts as a hormone and is itself the most potent endogenous vasoconstrictor substance known. Secondly angiotensin II (3) stimulates the adrenal cortex to release the hormone aldosterone which acts on the kidneys to regulate the electrolyte balance of body fluids by promoting excretion of potassium ions and retention of sodium ions and water. In addition to converting angiotensin I (2) to angiotensin II (3) ACE catalyses the hydrolysis of the two C-terminal dipeptides from the potent vasodilator nonapeptide bradykinin (4), Figure 1, thereby rendering it inactive.

All three mechanisms result in hypertension and an increase in blood pressure. As the inhibition of ACE would result in the shut down of all three of these actions it has become an important target for the design of anti-hypertensive drugs. A number of excellent reviews on the developmental history of the drugs currently in clinical use for this disease have been published.¹⁻³ The following is a brief overview of this area.

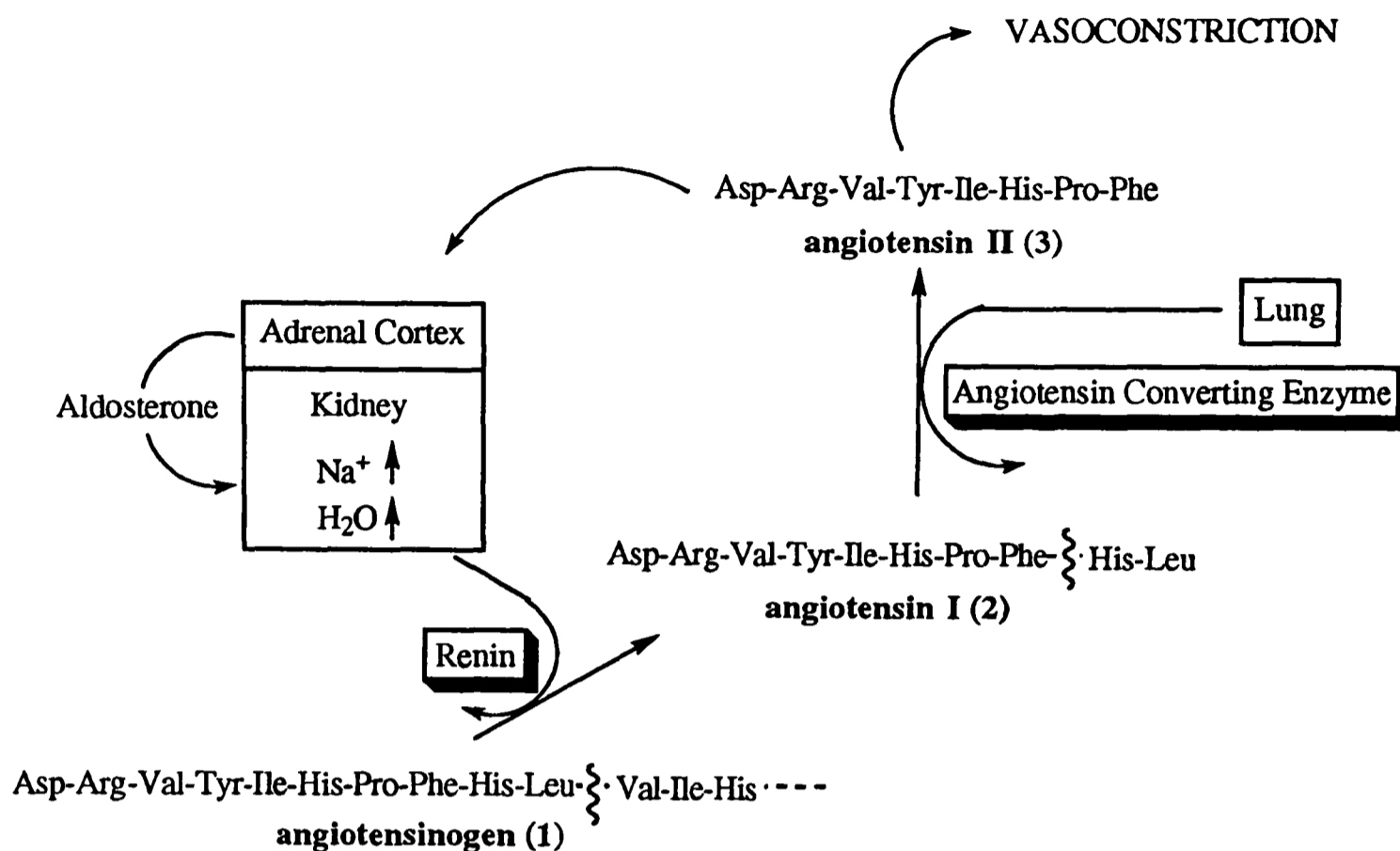

Scheme 1

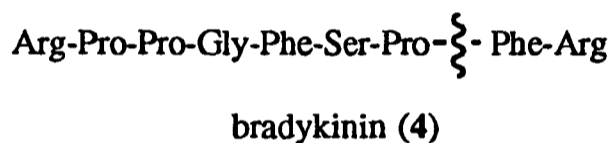

Figure 1

8.2. First Generation ACE inhibitors

In the 1960s and 1970s mixtures of polypeptides obtained from several snake venoms were shown to inhibit ACE. Of the constituent peptides that were isolated and sequenced a nonapeptide (<Glu-Trp-Pro-Arg-Pro-Gln-Ile-Pro-Pro) (named SQ2881 or teprotide) (5) was shown to exhibit the longest duration of inhibitory and antihypertensive action *in vivo*.^{4,5} As these compounds were peptides they were not effective when administered orally, however they provided the scientific basis for the design of orally active drugs.

The problem to be solved was that of finding small-molecule alternatives to relatively large peptides which show the desired pharmacological effect but are poorly absorbed, rapidly metabolised or both. The fact that *N*-acylated tripeptides were also found to be substrates for ACE indicated that the development of a small, orally active ACE inhibitor was a realistic possibility. In these peptides the potency was found to be greatest with proline in

the C-terminal position, alanine in the penultimate position and an aromatic amino acid in the antepenultimate position.⁶

When the search for a potent ACE inhibitor was initiated by Bristol Myers Squibb and Merck pharmaceutical companies, little was known about ACE other than it was a zinc containing exodipeptidase.⁷ However, it was reasoned that ACE might be similar to the pancreatic carboxypeptidase A, another zinc containing protease. Carboxypeptidase A was one of the better understood metalloproteases with a known X-ray structure.⁸ It is an exopeptidase which selectively cleaves an aromatic amino acid from the C-terminus of its substrates. The active site contains a cationic binding site for the carboxylate anion, a group which binds the C-terminal amino acid side chain and a zinc cation which activates the amide carbonyl to hydrolysis. (*R*)-2-benzylsuccinic acid (**6**) which can bind at all three of these sites was found to be a potent inhibitor of this enzyme,⁹ Figure 2.¹⁰

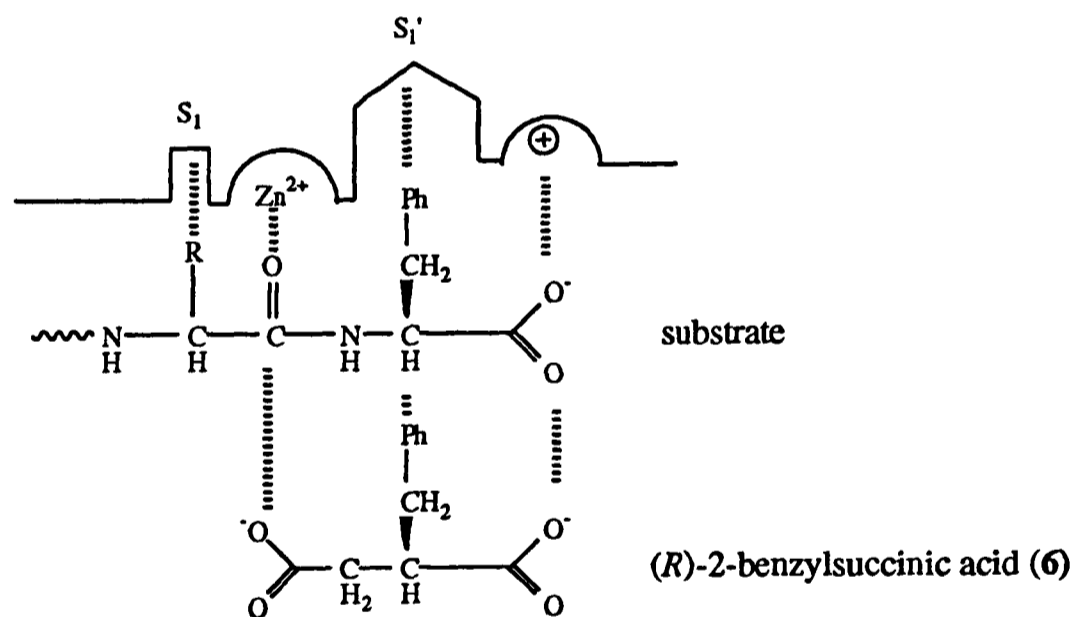

Figure 2

It was reasoned that the potent inhibition of carboxypeptidase A by (**6**) was derived from the resemblance of the inhibitor to the products of hydrolysis of the substrate, Figure 3.⁹

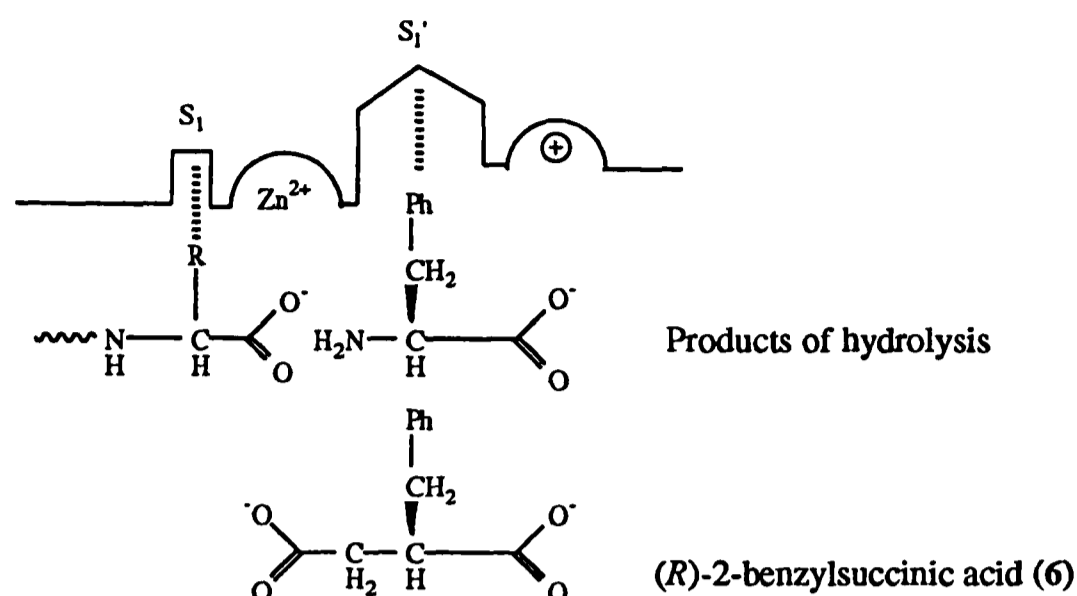

Figure 3

It was further reasoned that a carboxyalkanoyl amino acid rather than (*R*)-2-benzylsuccinic acid (6) would be a more appropriate starting point for the design of inhibitors for ACE since ACE cleaves the C-terminal dipeptide from angiotensin I. This was in contrast to carboxypeptidase A which cleaves a single amino acid from the C-terminus of its substrate. As proline was the C-terminal amino acid common to all the naturally occurring peptide inhibitors and the more active synthetic tripeptides, it was chosen as the terminal amino acid in the proposed inhibitors. Succinoyl proline (7), the first of the carboxyalkanoyl derivatives to be synthesised was a weak competitive inhibitor of ACE. A number of structural changes were made in order to increase the potency, the most important of which was the replacement of the carboxylate with a thiol group, a better Zn (II) co-ordinating ligand. The drug which emerged was captopril (8), a competitive inhibitor of ACE with a K_i of $1.7 \times 10^{-8}M$ which was as potent as teprotide (5) but also orally active, Figure 4.¹ In addition (8) was shown to be highly specific for ACE even with respect to other Zn (II) metalloproteases.¹¹ The suggested interaction of (7) with ACE is depicted in Figure 5.¹⁰ The active site of ACE is believed to have two additional sites (compared to carboxypeptidase A) between the Zn (II) and the group which interacts with the C terminal carboxylate.

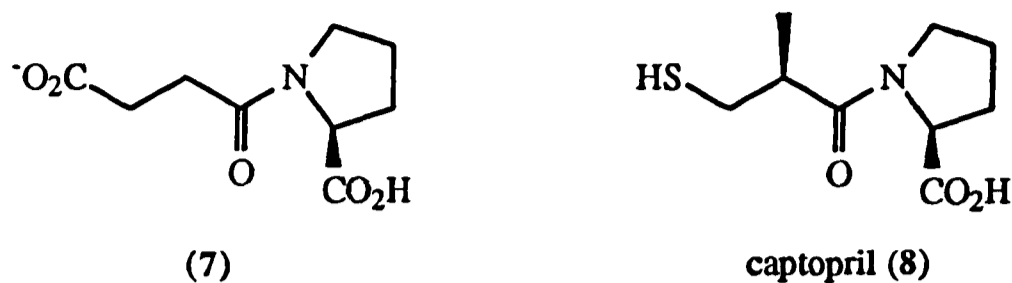

Figure 4

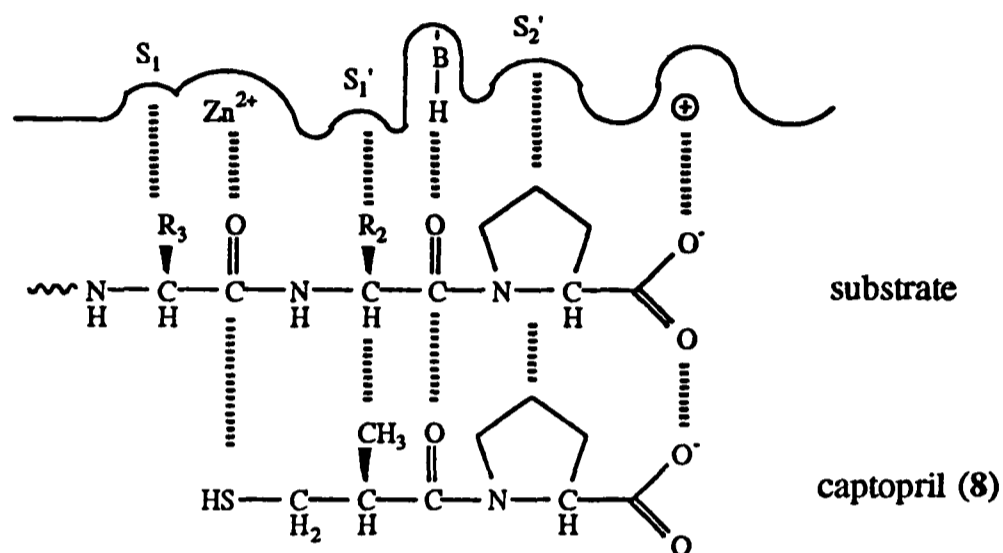

Figure 5

Captopril was the first ACE inhibitor on the drug market and has been shown to be a valuable agent in the treatment of hypertension and congestive heart failure. Unfortunately the side effects (*e.g.* loss of taste and skin rashes) caused by (8) have limited its therapeutic use and prevented it from assuming a predominant rôle as an anti-hypertensive agent. It has been postulated that the thiol group is primarily responsible, as similar effects arise when penicillamine is administered.¹² Furthermore, as thiols undergo facile *in vivo* oxidation to disulfides it was hoped that deletion of this group would give rise to metabolically more stable inhibitors.

8.3 Second Generation ACE Inhibitors

Merck re-investigated the use of carboxyalkanoylproline analogues of (7), *vide supra*, and attempted to increase their potency by adding extra groups which could further interact with additional binding sites on the enzyme. Firstly to make the compounds more similar to the normal enzyme hydrolysis products an NH was substituted for the CH₂. This led to a

reduction in potency, thought to be a result of the increased hydrophilicity of the compounds. To counterbalance this effect additional hydrophobic groups were appended. The addition of a methyl group ($R=Me$, $R'=H$) lead to a fifty-five-fold increase in potency. Further modification of the side chain¹² resulted in the development of enalaprilat (**9**) ($R=(S)$ - CH_2CH_2Ph , $R'=H$), Figure 6, which had an IC_{50} nineteen times lower than captopril. This may indeed be as a result of additional interactions between enalaprilat (compared to captopril) with the enzyme, such as hydrophobic interactions of the side chain with the S_1 subsite, Figure 7. An alternative explanation is that enalaprilat (**9**) is acting as a tight binding transition state analogue.³

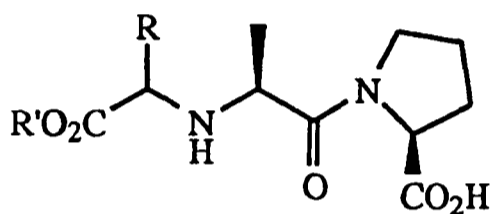

enalaprilat (**9**) $R=(S)$ - CH_2CH_2Ph , $R'=H$
 enalapril (**10**) $R=(S)$ - CH_2CH_2Ph , $R'=Et$

Figure 6

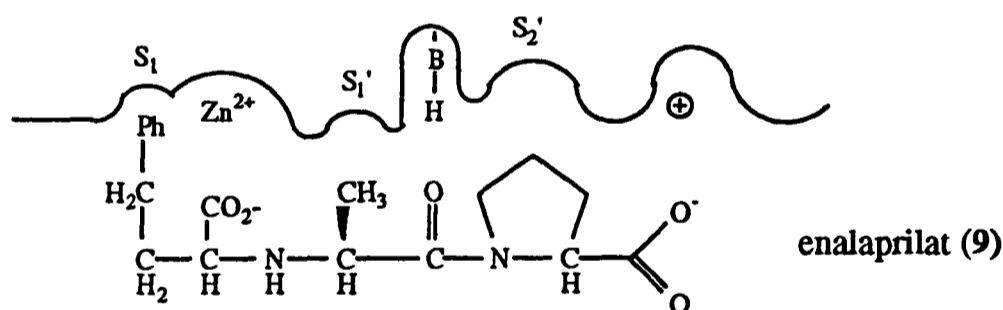

Figure 7

The side effects observed with captopril (**8**) are rarely seen with enalaprilat (**9**) but a major drawback with (**9**) was that it was poorly absorbed and could only be given by intravenous injection. This problem was, however, overcome by converting the carboxy group to an ethyl ester generating the drug enalapril (**10**) ($R=(S)$ - CH_2CH_2Ph , $R'=H$) which had excellent oral activity, Figure 6. Enalapril is thus an example of a prodrug which requires metabolic activation by esterases in the body to liberate the active form, enalaprilat.

An alternative to enalapril was also developed at Merck. Lisinopril (11), a lysylproline analogue, was more slowly and less completely absorbed than enalapril (10) but showed a longer duration of action and did not require metabolic activation. The most potent diastereoisomer of (11) had the stereochemistry *S,S,S* which is also that found in enalapril (10). More recently Bristol Myers Squibb have reported a new class of potent ACE inhibitors, the (hydroxyphosphinoyloxy)acyl amino acids *e.g.* (12) where similar binding interactions to the enzyme are possible, Figure 8.¹³

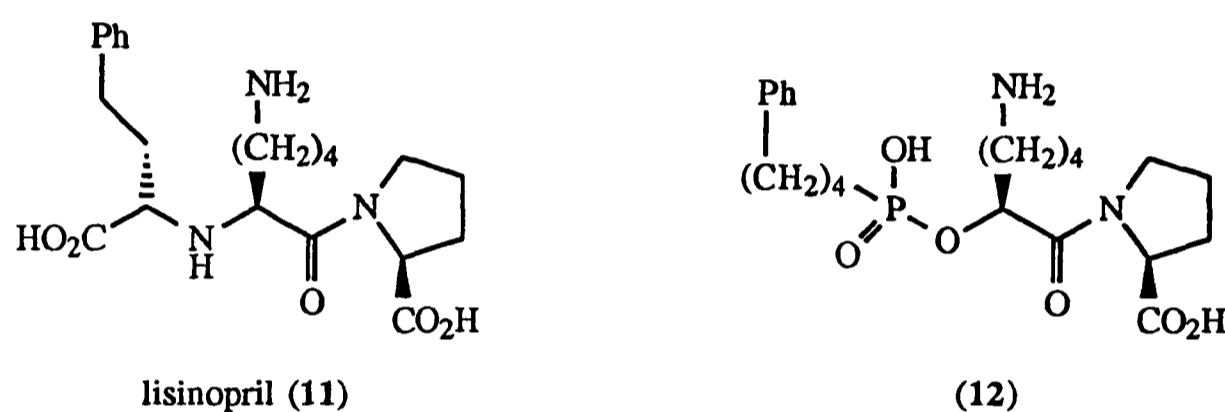

Figure 8

Thus, orally active ACE inhibitors have established themselves in the therapy of hypertension and congestive heart failure. Although other mechanisms involved in the control of blood pressure have also been targeted, the inhibition of ACE continues to be one of the prime objectives in the treatment of this condition. The strategy adopted in the development of these drugs utilised some understanding of enzyme mechanisms at the molecular level and was the first and remains one of the classic examples of rational drug design.

8.4 Naturally Occurring ACE Inhibitors

The critical rôle played by the snake venom peptides played in establishing the clinical value of ACE inhibitors was discussed in Section 9.2. Phosphoramidon (13),¹⁴ Figure 9, has also been of importance in regard to the phosphorous based designs such as (12), Figure 8. The search has continued for novel inhibitors of ACE from natural sources and a number of those more recently isolated from microbial sources are shown in Figure 9.² The majority

are produced by strains of Actinomycetes *e.g.* (14)-(17) with only aspergillomarasmines A (18) and B (19), Figure 9 and WF-10129 (20) (Figure 10, Section 9.5.1) originating from fungi. It is thus apparent that a range of chemical entities can act as ACE inhibitors. A variety of mechanisms have been proposed to account for their activity, for example, (14) is proposed to inhibit ACE by specifically chelating to the enzyme bound zinc cation whereas (18) and (19) are believed to act by sequestering zinc from the enzyme.²

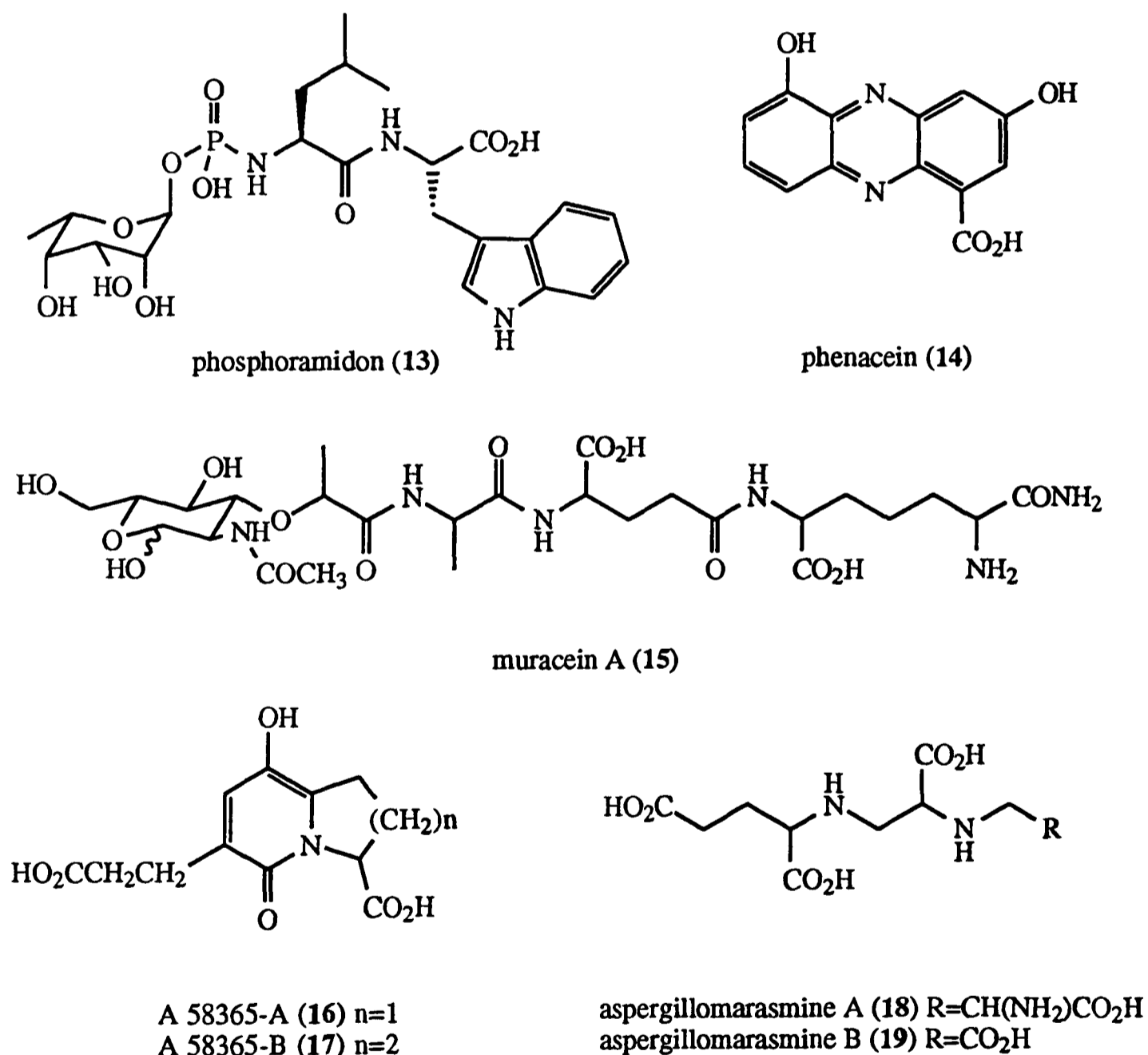
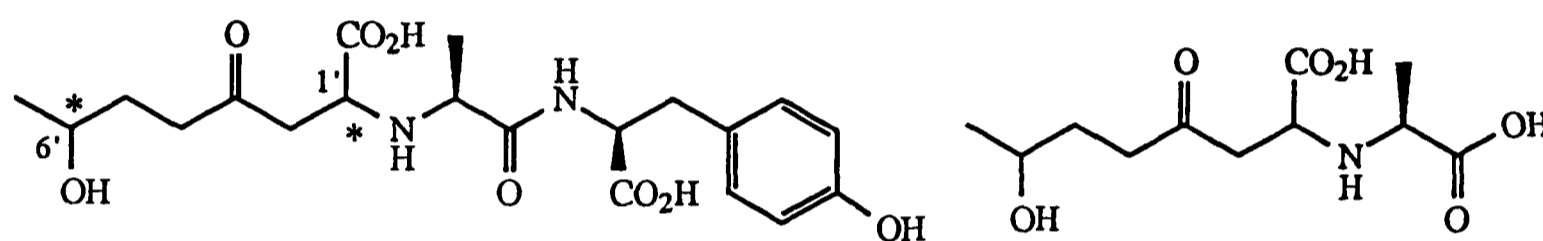

Figure 9

8.5 WF-10129, a Naturally Occurring ACE Inhibitor

8.5.1 Isolation, Structure and Biological Activity

In 1987 the ACE inhibitor WF-10129 (**20**) was isolated by Ando *et al.* from a culture of the fungus *Doratomyces putredinis*.¹⁵ The IC₅₀ of WF-10129 (**20**) for ACE was reported as 1.4×10^{-8} M an activity comparable with that of the synthetic ACE inhibitor captopril, (IC₅₀; 1.7×10^{-8} M when assessed in the same experiment), thus indicating that WF-10129 is one of the most potent ACE inhibitors isolated from a microbial product.



Possible Diastereoisomers:

(21)

(20a) *S, S, S, S*; (20b) *6'R, 1'S, S, S*(20c) *R, R, S, S*; (20d) *6'S, 1'R, S, S*

Figure 10

The structure of (**20**) was elucidated by spectroscopy and chemical degradation. Degradation studies involved hydrolysis of (**20**) with 6M HCl (110°C for twenty-two hours) to generate (*L*)-alanine and (*L*)-tyrosine and hydrazinolysis (100°C for six hours) to generate (*L*)-tyrosine as the sole amino acid product thereby indicating that (*L*)-tyrosine is located at the C-terminus. Thus, (**20**) was proposed to be a dipeptide composed of (*L*)-tyrosine and the novel amino acid (**21**), itself encompassing an (*L*)-alanine residue. It is of interest to note that (**20**) is therefore a substituted *N*-carboxyalkyl dipeptide, a structural feature which is shared with the synthetic ACE inhibitors enalapril (**10**) and lisinopril (**11**) developed independently of this chemical lead. WF-10129, however, differs from these more potent inhibitors in possessing tyrosine rather than proline as the C-terminal amino acid. No X-ray data were reported and the relative and absolute stereochemistries at two centres (*) were not determined. At the onset of this work no synthetic routes to WF-10129 had been published and so the issue of stereochemistry remained unresolved. Taken together, the biological

activity, the unusual structure and stereochemical uncertainties of WF-10129 (**20**) are factors which argued strongly for an independent chemical syntheses to unambiguously solve these problems. A synthetic strategy which would allow for not only the preparation of the gross structure but also any of the possible stereoisomers of (**21**) was required. Ideally this strategy would also allow the preparation of a number of analogues of (**20**) to probe structure-activity relationships. The effect on potency arising from the replacement of tyrosine with proline and the rôle/importance of the secondary hydroxyl and its stereochemistry, would, for example, be worthy of investigation.

8.5.2 Retrosynthetic Analysis of WF-10129

As mentioned above retrosynthetic analysis of (**20**) gives (**21**) and (*L*)-tyrosine. Any one of a number of strategies to the *N*-carboxy substituted (*L*)-alanine residue of (**21**) may then be adopted. Examples of previously reported routes to this functional group are shown in Scheme 3. The first two examples, which lead to the formation of diastereomeric mixtures, involve reductive amination between a ketone and an amine¹⁶ and the Michael addition of an amine to a ketoacrylate respectively.^{17,18} The remaining two examples involve the S_N2 reaction of an amine with a triflate.^{17,19,20} Provided enantiomerically pure triflates are utilised either of these approaches result in the formation of a single diastereoisomer of product. As it would be essential to unambiguously assign the stereochemistry of (**21**) in order to correctly determine the stereochemistry of WF-10129 (**20**) the strategy indicated in Scheme 3 was designed. This convergent approach would potentially allow for the ready preparation of analogues of WF-10129 (**20**). As variously protected versions of both (**35**) and (**36**) were known, the problem reduced to the stereochemically controlled preparation of the unusual γ -keto- α -amino acid (**34**).

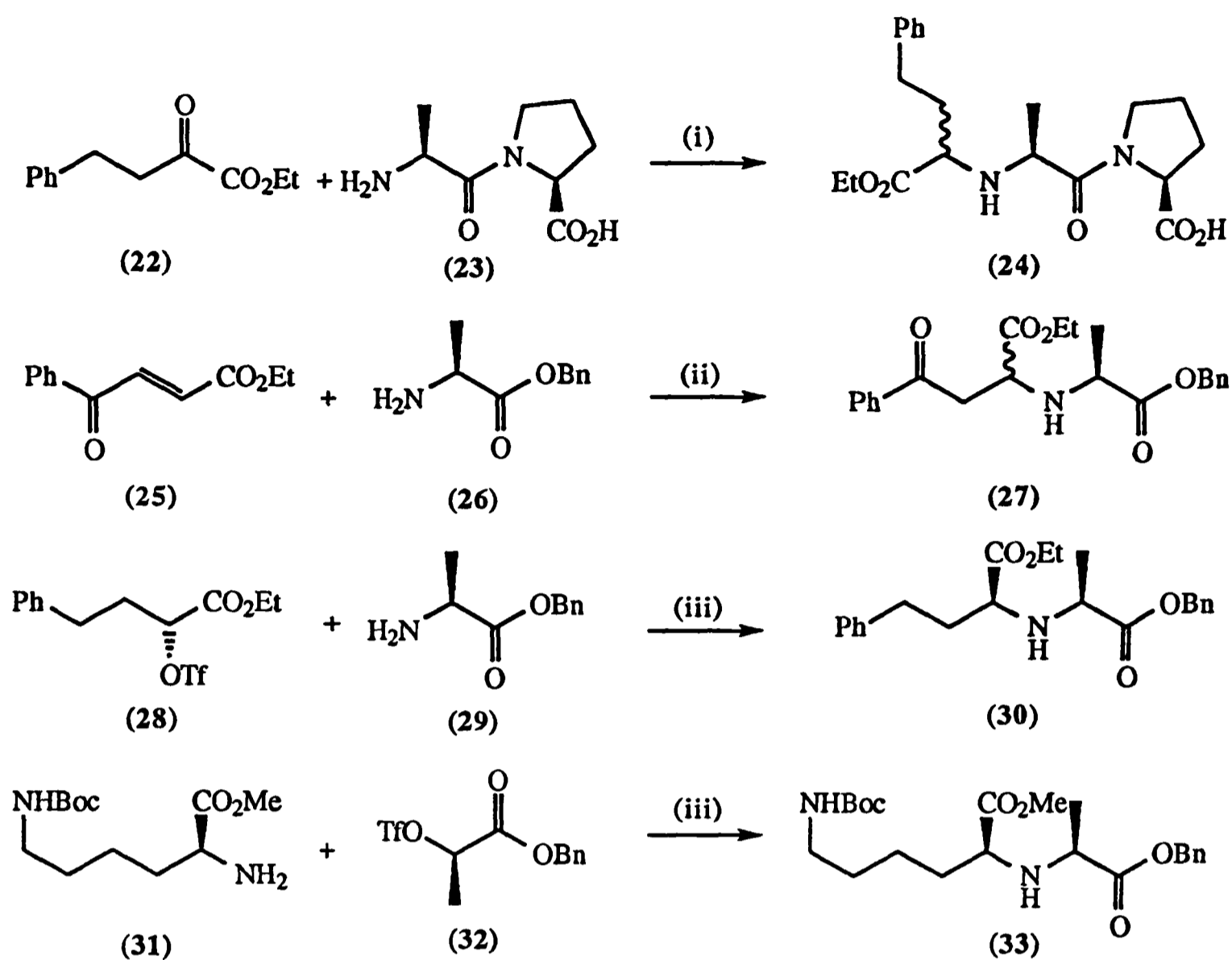

(i) EtOH, mol. sieves then NaBH₃CN; (ii) Et₃N, EtOH; (iii) Et₃N, DCM.

Scheme 2

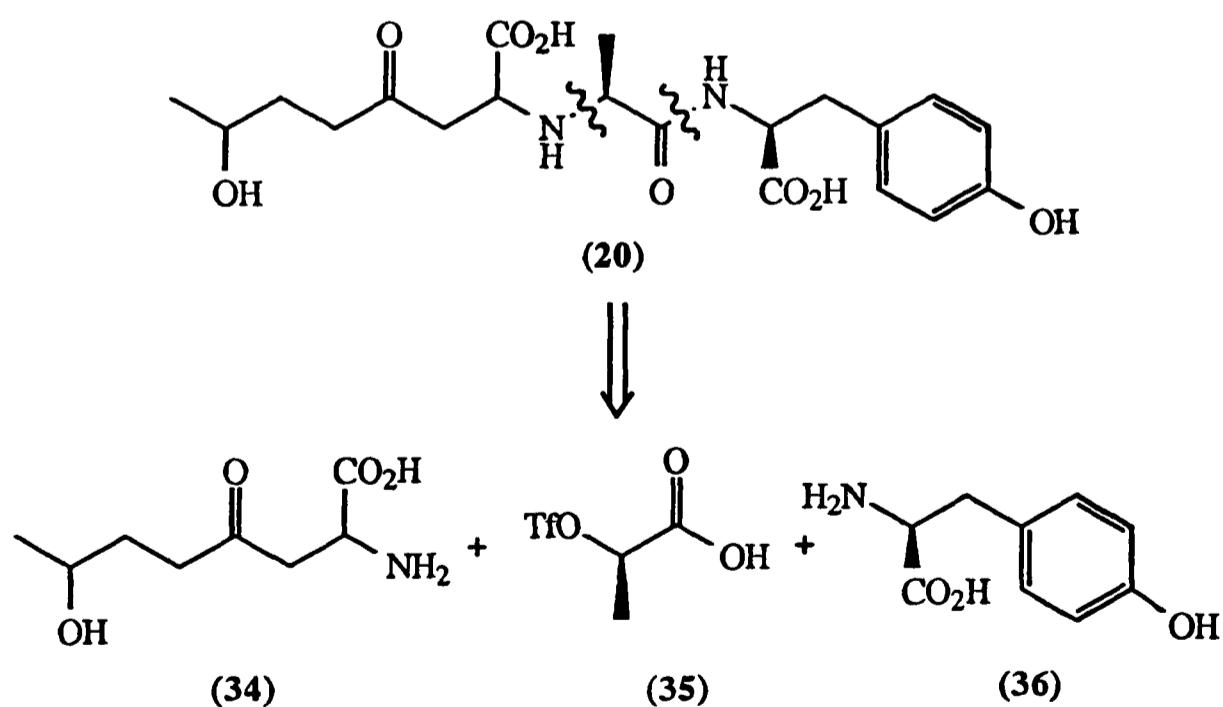

Scheme 3

Chapter 9

γ -Keto- α -Amino Acids

9.1 Non-Proteinogenic Amino Acids

The non-proteinogenic amino acids are secondary metabolites which may be defined as those amino acids "which are not found in protein main chains for lack of a specific transfer RNA and codon triplet or because they do not arise from protein amino acids by post-translational modification."²¹ At last count in 1988 their number was rapidly approaching 1000,²² the majority being found in plants and microorganism.²¹ Like other secondary metabolites the non-proteinogenic amino acids are often characteristic of an individual genus or strain, being formed along specialised routes.²³ In many cases they been found to be of importance to the producing organism where they may act, for example, as deterrents (*e.g.* pheromonal) or have a physiological (*e.g.* toxic) effect and hence play a key rôle in the survival of the species in the presence of competitors. The biological activity exhibited by these amino acids has made them of considerable interest to the pharmaceutical industry. They have also been utilised in molecular biology *e.g.* as enzyme inhibitors and find use in cosmetics, agrochemicals, materials science and in the food industry as flavourings, taste enhancers and sweeteners.²⁴ Further demand for large quantities of these secondary metabolites as well as unnatural novel amino acids in both the industrial and academic sectors is inevitable in view of their important biological activity.²²

9.2 γ -Keto- α -Amino Acids as Natural Products

The γ -keto- α -amino acid moiety exemplified in WF-10129 is found in a number of secondary metabolites. Kynurenine (39) and its *N*-formyl derivative are, for example, important intermediates in the biosynthesis of quinolinic acid (41) from (*L*)-tryptophan

(37).²⁵ Kynureninase, a key enzyme in this pathway, is proposed to convert (39) to anthranilic acid (40) which is further metabolised to (41), Scheme 4. As quinolinic acid has recently been implicated in the aetiology of Huntington's chorea and other neurodegenerative disorders,^{26,27} the synthesis of γ -keto- α -amino acid analogues of (39) as potential inhibitors of kynureninase has recently been attempted, *vide infra*.

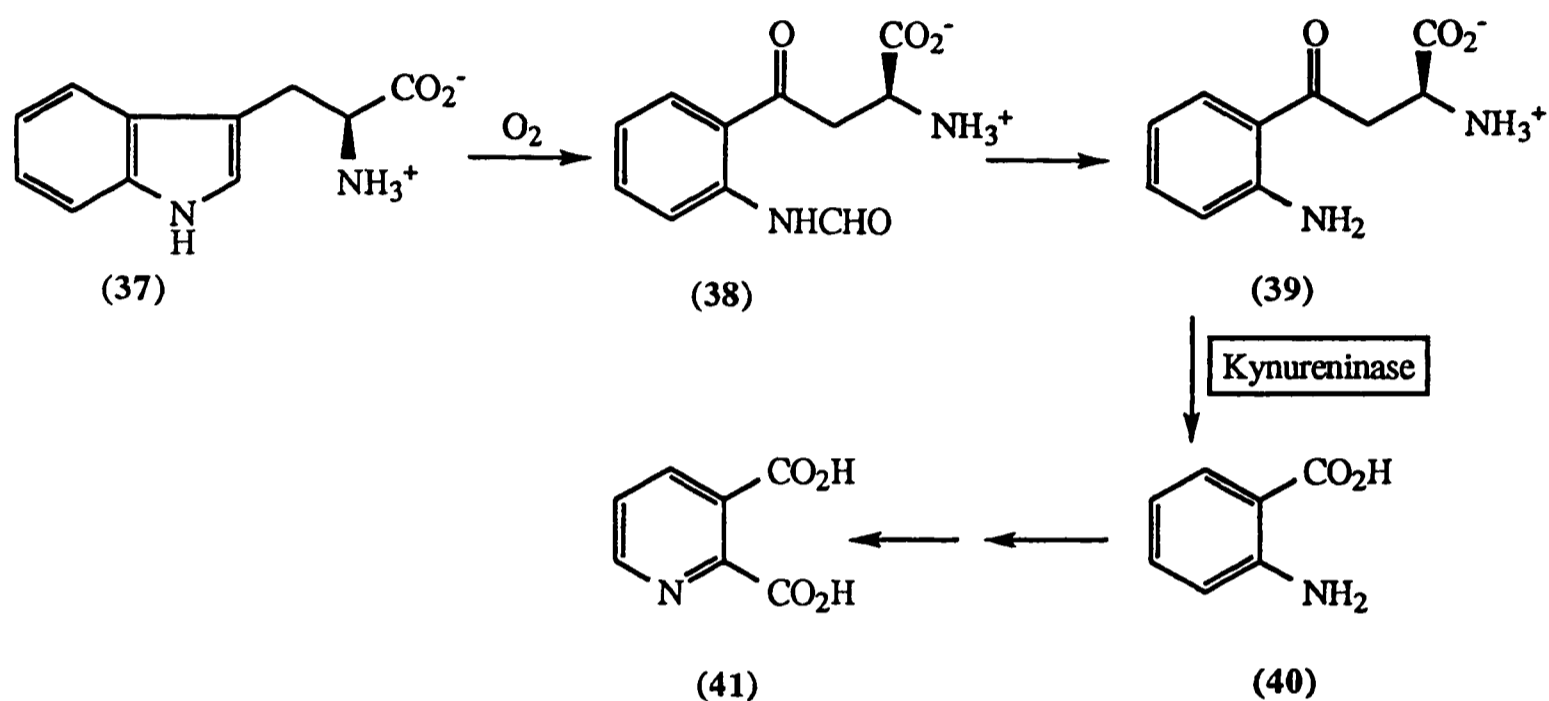

Scheme 4

5-hydroxy-4-oxo-(L)-norvaline, (-)-HON, (42) was discovered in Japan in 1958 in the culture broth of *Streptomyces akiyoshienis novo* sp. and found to exhibit antibiotic activity against human and bovine types of tuberculum.²⁸ The structure of (42) was determined by Mikaye *et al.* in 1960 and confirmed by racemic total synthesis, Figure 11.^{29,30}

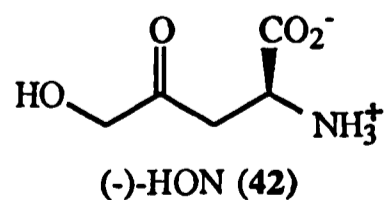
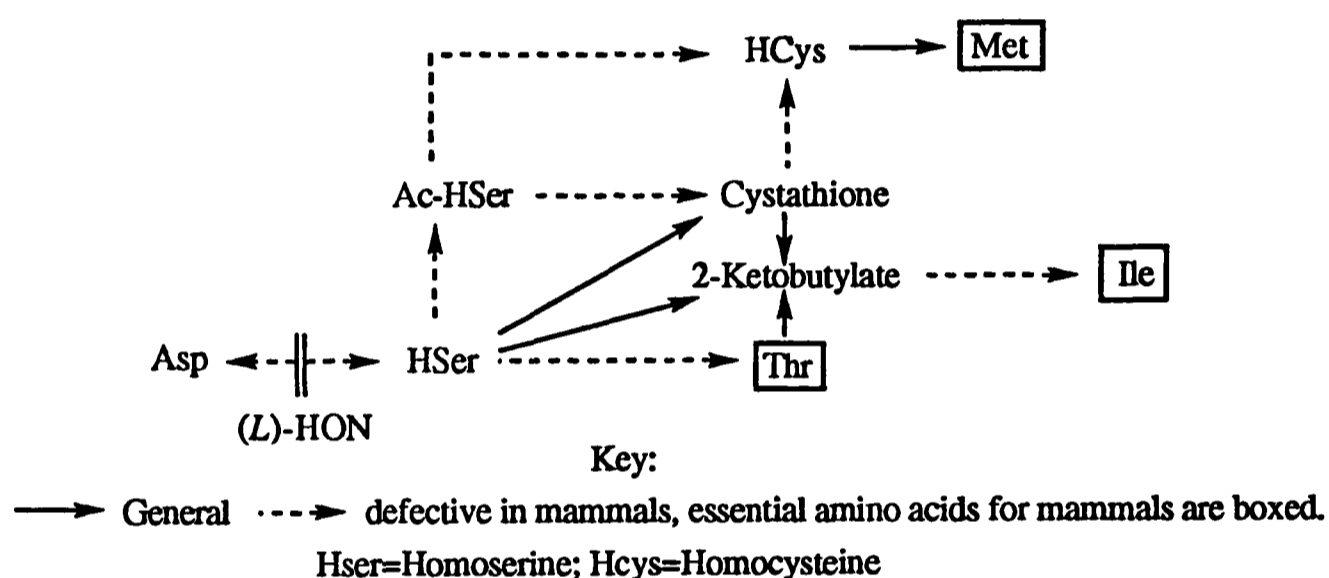

Figure 11

More recently, the observation that (-)-HON (42) displays potent antifungal activity against *Candida albicans*, *Cryptococcus neoformans* and other yeasts and is highly tolerated by

experimental animals has led to the suggestion that it may find use as an orally administered drug for the treatment of mycotic diseases in humans and other animals.³¹ The novel mode of action of (42) is of interest as it may explain its low toxicity toward mammals.³²⁻³⁴ (-)-HON is able to specifically inhibit homoserine dehydrogenase, an enzyme that converts aspartate semialdehyde to homoserine, which leads to the depletion of (*L*)-threonine, (*L*)-methionine and (*L*)-isoleucine in the cellular pool. As these amino acids are not biosynthesised by mammals, (-)-HON displays selective toxicity toward fungi and other prototrophic organisms, Scheme 5. A study on the biosynthesis of (-)-HON was recently reported.³⁵



Scheme 5

The related, synthetic, γ -keto- α -amino acid (*L*)-2-amino-4-oxo-5-chloropentanoic acid (43) shows similar inhibitory properties toward a homoserine dehydrogenase³⁶ and also shows a covalent interaction at the glutamate binding site of γ -glutamylcysteine synthetase³⁷ and a phosphate dependent glutaminase, Figure 12.³⁸ Furoylalanine (44) has been isolated and characterised from *Fagopyrum esculentum* (buckwheat seeds)³⁹ and 4-oxo-norleucine (45) has been obtained from the acid hydrolysates of a polysaccharide obtained from *Citrobacter freundii*, Figure 12.⁴⁰ Their structures have been confirmed by racemic total synthesis.

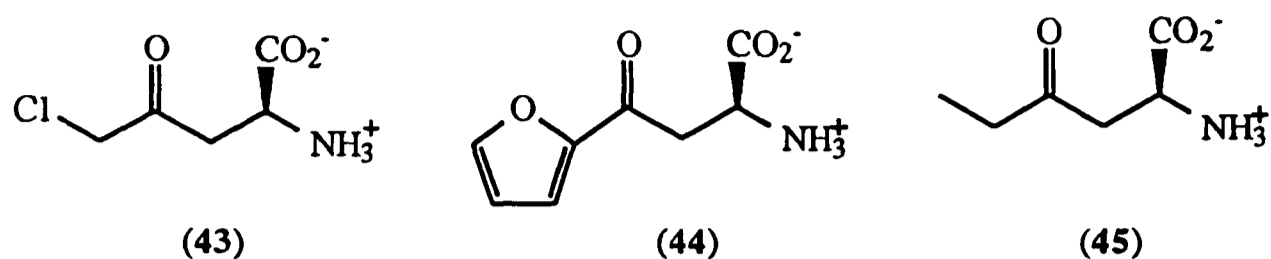

Figure 12

9.3 Syntheses of γ -Keto- α -Amino Acids

The biologically important activity displayed by naturally occurring, as well as unnatural, γ -keto- α -amino acids has attracted the interest of synthetic organic chemists. The preparation of this moiety is also important in the context of the synthesis of other functional groups, for example γ -keto- α -amino acids may be readily converted to γ -hydroxy- α -amino acids, (more stable in the γ -lactone form),⁴¹ to α - γ -diamino acids on reductive amination and to heterocyclic α -amino acids on treatment with hydrazine. The following is an overview of the strategies adopted in the synthesis of this functionality which may be broadly divided into four groups.

9.3.1 Application of Glycine Cation Equivalents

The synthesis of a series of racemic *N*-methoxycarbonyl- γ -oxo- α -amino acid methyl esters (**49**) through Lewis acid induced coupling of the corresponding chloroglycine derivatives with silyl enol ethers was recently reported by Speckamp, Scheme 6.^{42,43} The products could be readily converted into the free amino acids as illustrated for the synthesis of racemic HON, Scheme 7.

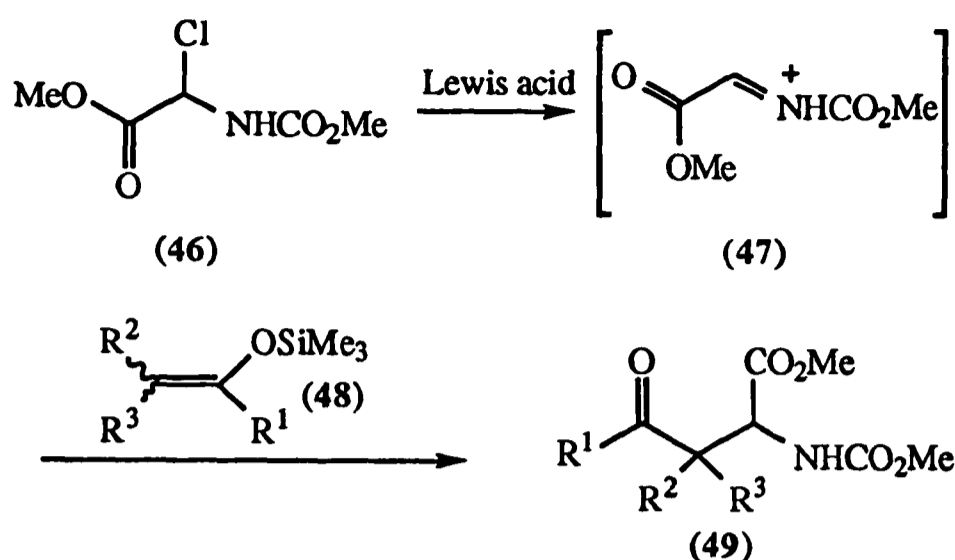

Scheme 6

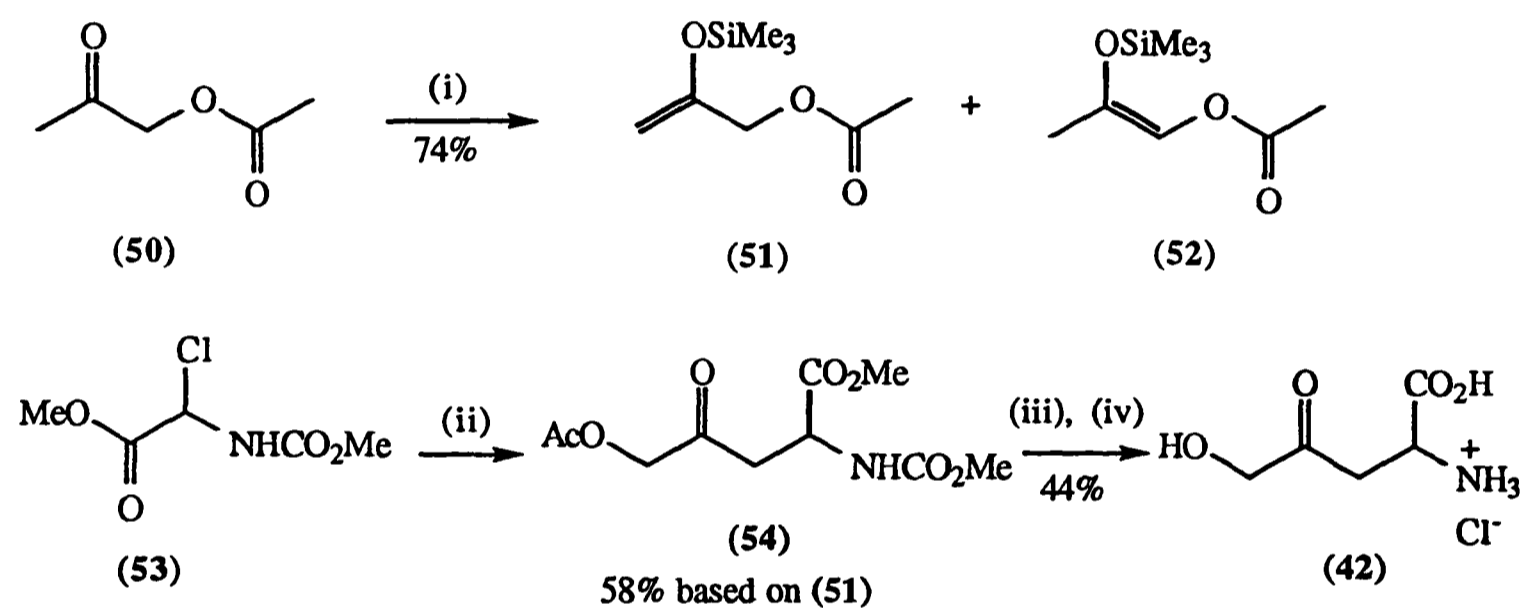

(i) Me_3SiCl , Et_3N , DMF, reflux, 6h.; (ii) (51) and (52), SnCl_4 , DCM; (iii) Me_3SiI , MeCN; (iv) 6M HCl.

Scheme 7

Ben-Ishai has reported the synthesis of *N*-acyl derivatives of γ -keto- α -amino acids by the amidoalkylation of 1,3 dicarbonyl compounds with glyoxylic acid-amide adducts such as (56) with concomitant decarboxylation.⁴⁴

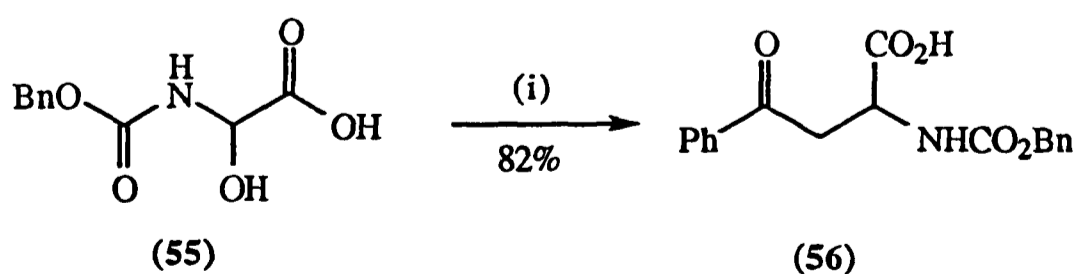

(i) benzoyl ethylacetate, conc. H_2SO_4 , 48h, RT.

Scheme 8

A similar method has been utilised by Whitten in order to synthesise the fluorinated γ -keto- α -amino acid derivative (60), a potential inhibitor of kynureninase, *vide supra*.⁴⁵

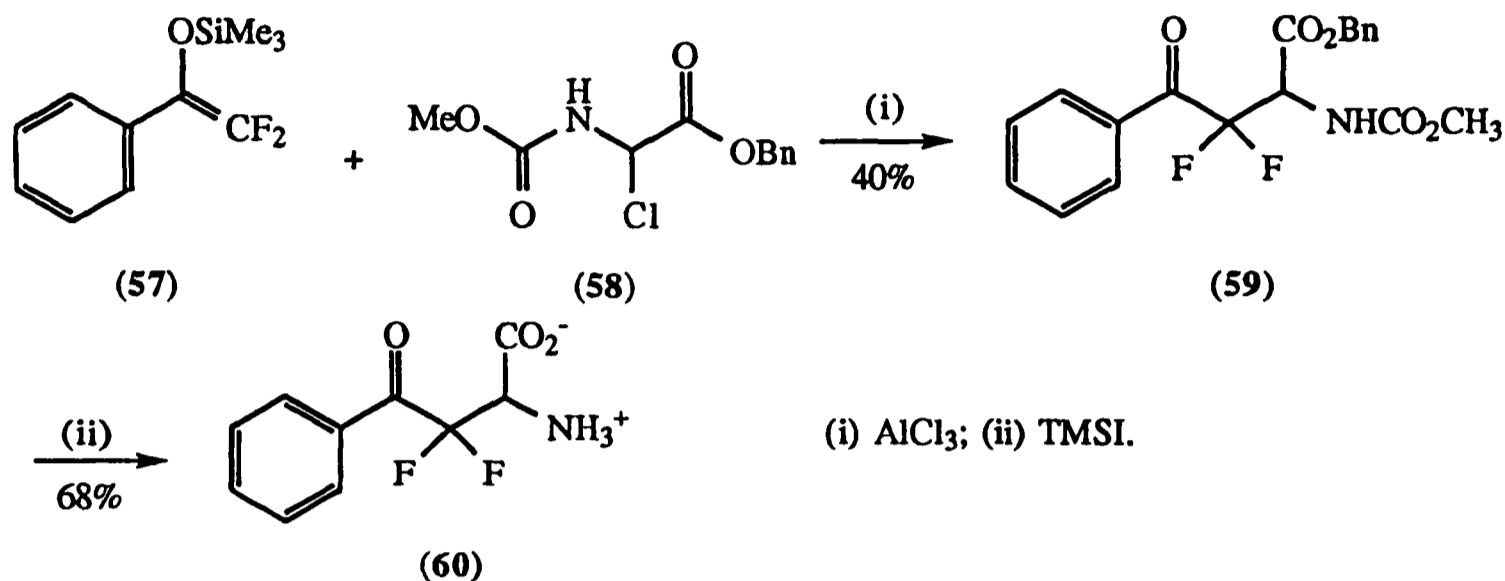

Scheme 9

The ene reaction of an electron deficient alkene (enophile) to an alkene (ene) with an allylic hydrogen atom where the latter is the enol form (C=C-O-H) of an aldehyde or ketone is relatively rare. The synthesis of γ -keto- α -amino acids has, however, been accomplished in this manner using butyl *N*-(*p*-toluenesulfonyl)iminoacetate (63) as the enophile. Thermal (120°C), uncatalysed reaction of (63) with, for example, acetone gives the adducts (64) in high yield.⁴⁶

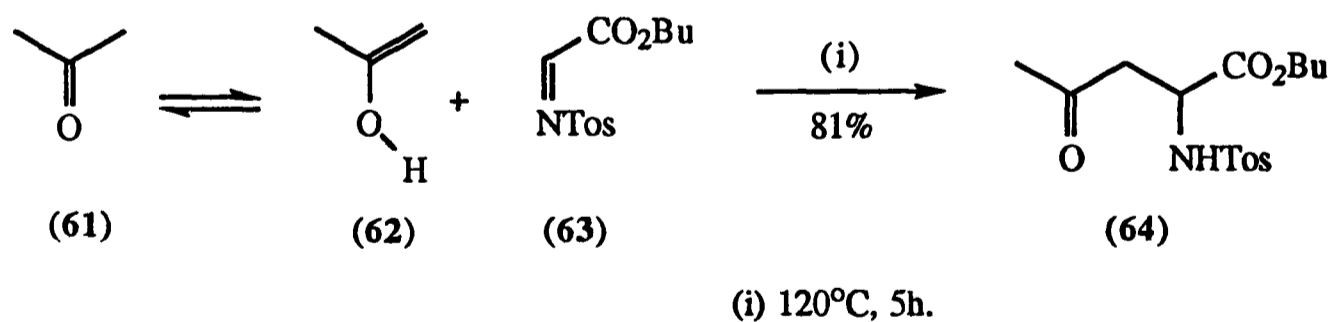

Scheme 10

The only diastereoselective and enantioselective synthesis of γ -keto- α -amino acid derivatives that utilises a glycine cation equivalent has been described by Enders and Steglich. These involve the reaction of an acyliminomalonates *e.g.* (66) with an enamine *e.g.* (68), Scheme 11.⁴⁷ By employing the concept of double stereodifferentiation, complete

asymmetric induction for the C-C bond formation was achieved. The *anti*-diastereoselectivity and enantioselectivity were interpreted by a Diels Alder like transition state, Scheme 12. The intermediate (69) may then undergo ring opening to zwitterion (70) or enamine (71) which on acidic work-up yields the observed product *anti*-(67).

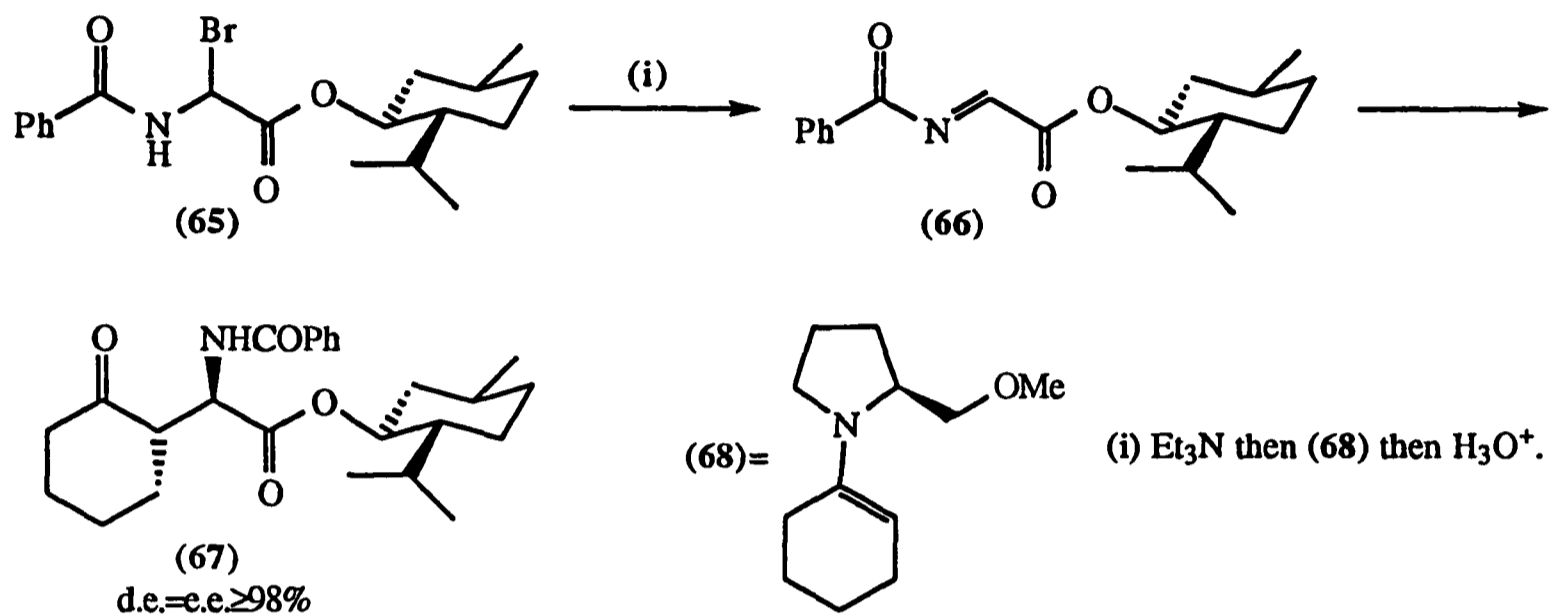

Scheme 11

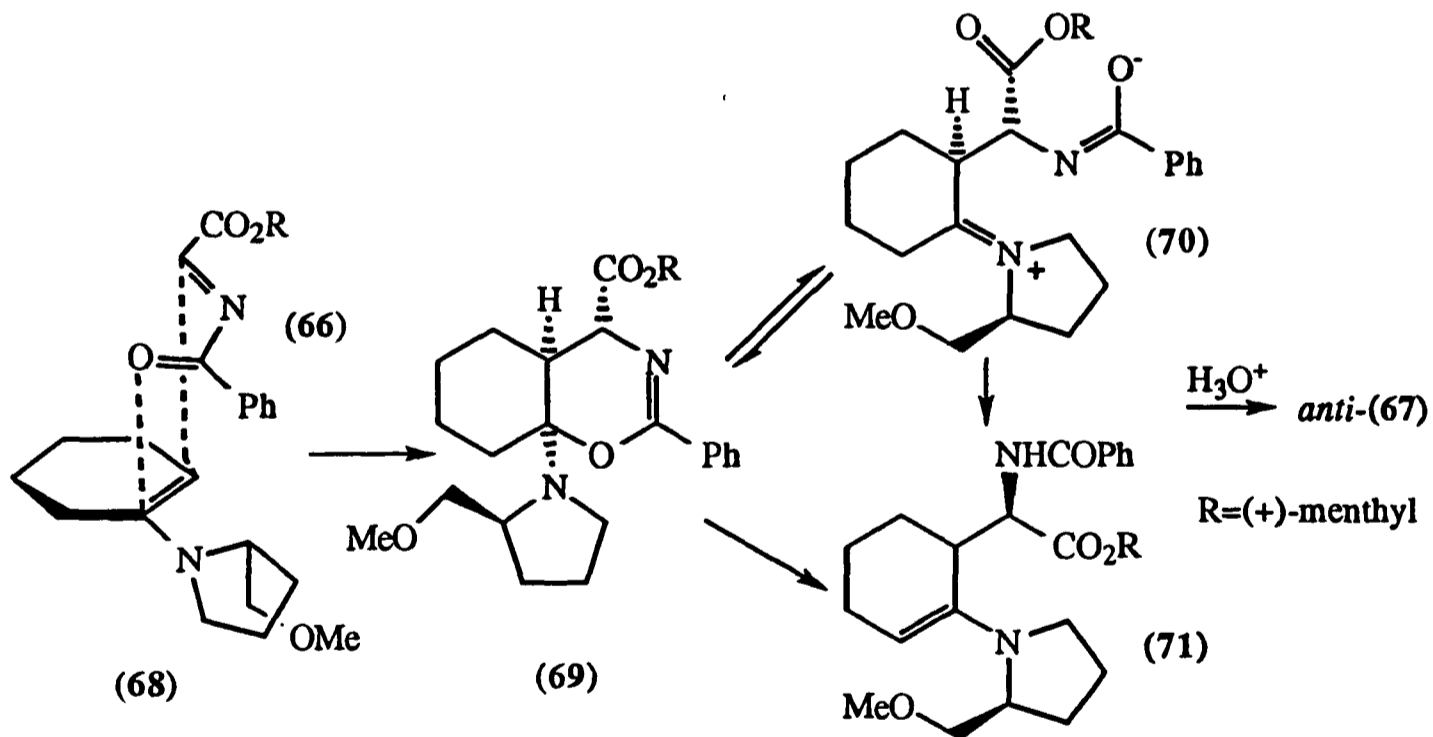

Scheme 12

9.3.2 Application of the Glycine Anion Equivalent

The synthesis of optically pure (-)-HON (42) has been accomplished by Schmidt. The dioxolane derivative (73) was obtained by the condensation of (72) and (76). Cleavage of the dioxolane, protection of the primary hydroxyl and subsequent diastereoselective

hydrogenation generated (75). Swern oxidation then afforded masked (-)-HON (42) which was deprotected using standard methods.⁴⁸

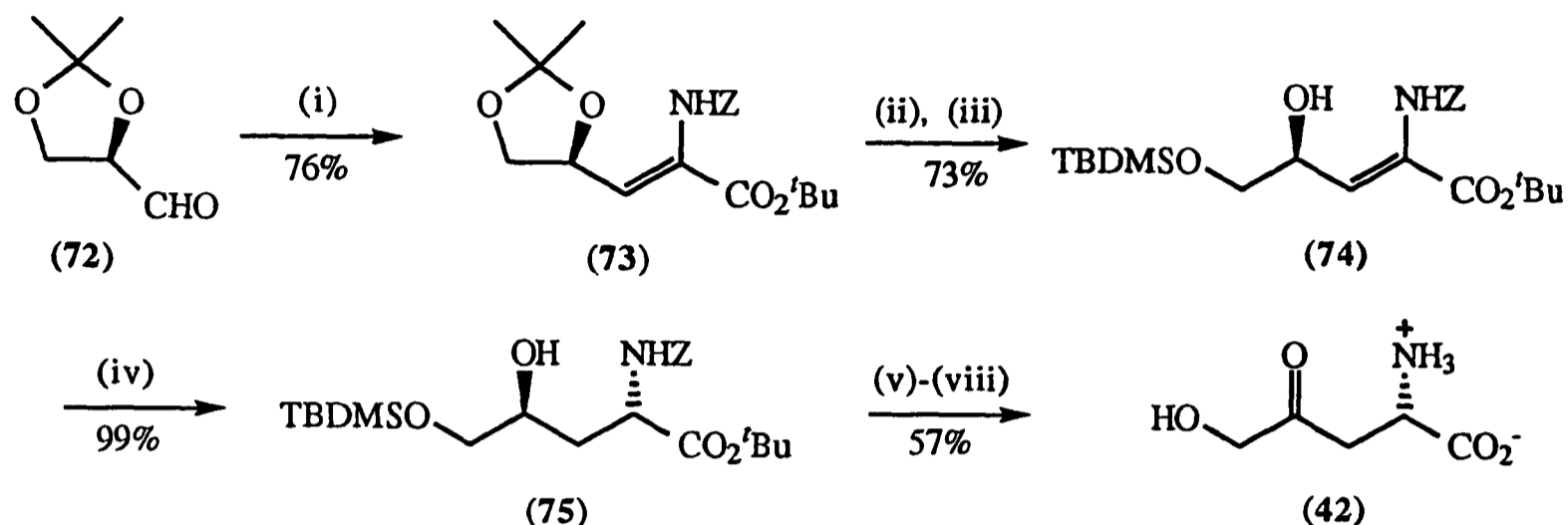

(i) $(\text{MeO})_2\text{P}(\text{O})\text{CH}(\text{NHZ})\text{CO}_2^t\text{Bu}$ (76), DBU, DCM, -20°C to RT, 1h.; (ii) HCl/H₂O, dioxane, 80°C , 1h.; (iii) TBDMSCl, Et₃N, DMAP, DCM, RT, 12h.; (iv) (R,R) -[Rh(1.5-COD)(DIPAMP)]⁺BF₄⁻, H₂ (3 bar), MeOH, RT, 12h.; (v) oxalyl chloride, DMSO, Et₃N, DCM, -55°C to RT, 30min.; (vi) Py-HF, MeCN, RT, 4h.; (vii) TFA, 0°C , 4h.; (viii) MeOH, 10% AcOH, Pd/C, H₂ (3 bar), RT, 1h.

Scheme 13

9.3.3 Application of Aspartic Acid Derivatives

The major drawback with the majority of the γ -keto- α -amino acid syntheses that utilise glycine equivalents (see Sections 8.3.1 and 8.3.2 above) is the lack of stereocontrol. In many cases in order to obtain optically pure γ -keto- α -amino acids by such methods separation of the enantiomeric mixture by derivatisation is required and even then establishing the absolute configuration of the separated amino acids is often not a straightforward task. A recent trend in the synthesis of non-proteinogenic α -amino acids is the development of general approaches from other α -amino acid precursors available from the chiral pool. Not surprisingly then, the majority of syntheses developed for the preparation of the γ -keto amino acid moiety over the last few years involve the use of suitable derivatives of aspartic acid, an amino acid that is readily available in both the *L* and *D* forms. Moreover, (*L*)-aspartic acid is one of the least expensive of the α -amino acids and is inexpensive enough to be seriously considered for industrial scale applications.

Déziel has reported the synthesis of several protected γ -keto amino acids such as (80) from (*L*)-aspartic acid.⁴⁹ Alkylation of the β -ketoester (78) prepared by the Masamune

protocol with various alkyl groups was best accomplished by treatment of (78) with Na_2CO_3 and the appropriate alkyl iodide in DMF. A disadvantage with this procedure is the competition between O and C-alkylation which results in only moderate yields for this step. Allyl ester cleavage and decarboxylation with pyrrolidine and a catalytic amount of $\text{Pd}(\text{PPh}_3)_4$ in acetonitrile then delivers the target material (80).

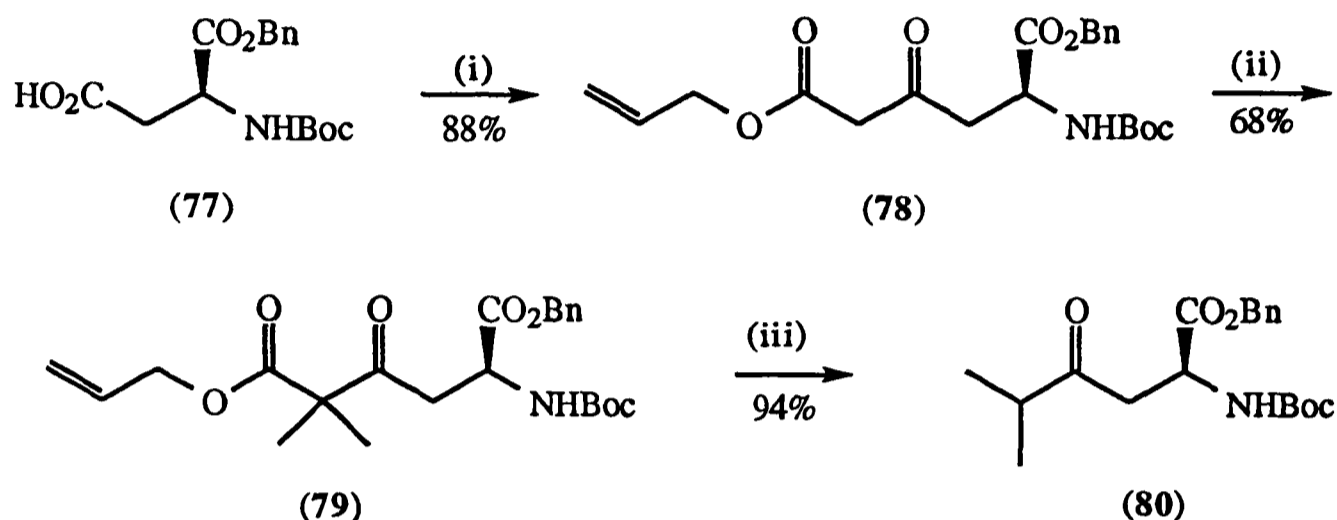

(i) Im_2CO , $(\text{C}_3\text{H}_5\text{OCOCH}_2\text{CO}_2)_2\text{Mg}$, CH_3CN , 25°C ; (ii) Na_2CO_3 (3 eq.), MeI , DMF , 60°C , 18h.; (iii) pyrrolidine, $\text{Pd}(\text{PPh}_3)_4$, 2.5mol.%, CH_3CN , 25°C , 18h.

Scheme 14

The excitatory amino acid (EAA) pathway, one of the major transmitter systems within the brain, has been an important area of investigation into the mammalian central nervous system (CNS). (*L*)-glutamate and (*L*)-aspartate are believed to be the primary endogenous ligands that effect the fast excitatory synaptic response in the CNS. The actions of these ligands is nonselective^{50,51} but at least three distinct EAA receptor subtypes have been classified on the basis of their response to selective agonists, the most well understood of which is the *N*-methyl *D*-aspartic acid (81) (NMDA) receptor. It is believed that antagonists of this receptor may, in the future, prove to be therapeutically useful agents in the treatment of neurodegenerative disorders such as Alzheimer's disease, in the prevention of neuronal damage that occurs during cerebral ischemia and as anticonvulsants. The development of an antagonist with effective *in vivo* activity has, therefore received much attention. The NMDA receptor has multiple regulatory sites and one of these, the glutamic acid binding site, is potently inhibited *in vitro* by phosphono-substituted (*D*)-amino acids *e.g.*

(82).⁵¹ Marion Merrell Dow have recently reported that the addition of a keto group in the γ -position generates the competitive antagonist (83) which not only exhibits increased receptor binding affinity *in vitro* but also potent activity *in vivo* (primarily as a result of improved blood-brain barrier penetration) and a rapid onset of the biological response, Figure 13.⁵²

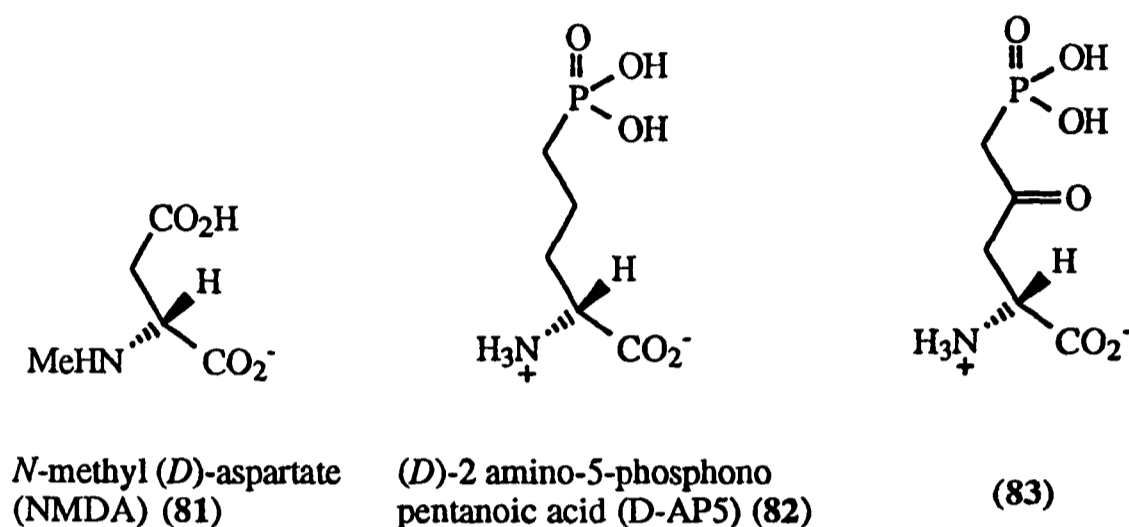
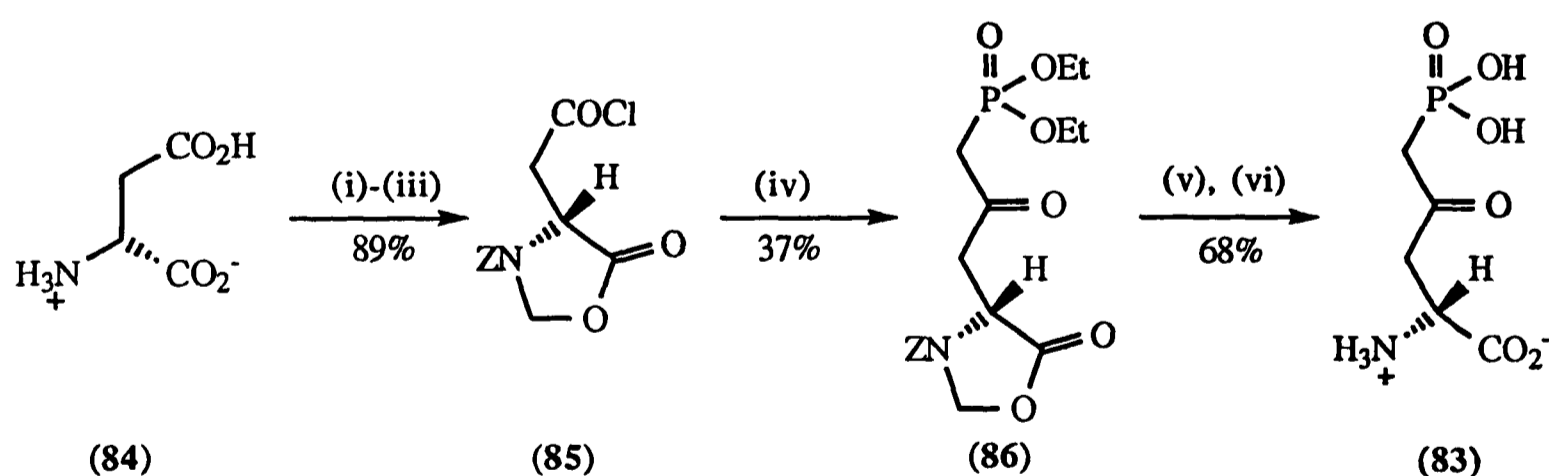

Figure 13

Two syntheses of (83) have been published by Marion Merrell Dow. Their first synthesis involved a copper catalysed coupling of (85) and a derivative of (*D*)-aspartic acid giving a low yield (37%) of (86). Complete deprotection was achieved using TMSI followed by ion exchange, Scheme 15.⁵²



(i) ZCl, NaOH; (ii) (CH₂)_nO, PTSA, reflux, PhH; (iii) SOCl₂; (iv) ((EtO)₂POCH₂)CuI, Et₂O, THF, -30°C; (v) TMSI; (vi) Dowex 50W-X8.

Scheme 15

In an attempt to synthesise (83) in a manner which could conveniently be carried out on a large scale, Marion Merrell Dow later developed a four step procedure from (*D*)-aspartic

acid that occurs without racemisation, as indicated in Scheme 16.⁵³ (*D*)-Aspartic acid (**84**) was converted into the *N*-trityl diester (**87**). Treatment of (**87**) with lithium methyl dimethylphosphonate at -78°C gave the corresponding β -ketophosphonates. Attempts to deprotect crystalline (**88**) using excess trimethylsilyl iodide gave the methyl ester of (**83**) but removal of all protecting groups was readily accomplished in one step with 5M HCl at reflux and followed by purification of the crude product by propylene oxide induced precipitation.

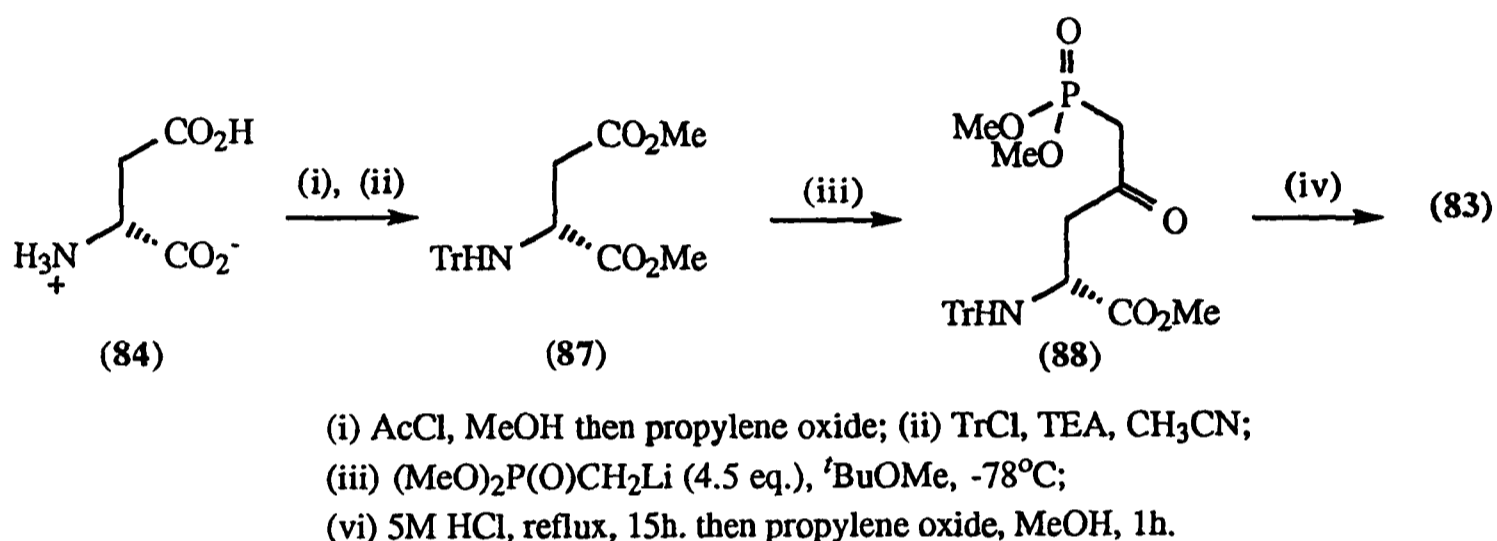

Scheme 16

Marion Merrell Dow have also synthesised a number of conformationally restricted β -ketophosphonic acids based on (**83**). Isomer (**93**), the most potent in binding studies, was synthesised using (*D*)-aspartic acid (**84**) as a chiral template. Treatment of key intermediate (**91**) (prepared in six steps from (**84**)) with lithium methyl diethylphosphonate chemoselectively afforded the fully protected chiral β -ketophosphonate (**92**) in 66% yield, which was deprotected in a two step procedure, Scheme 17.

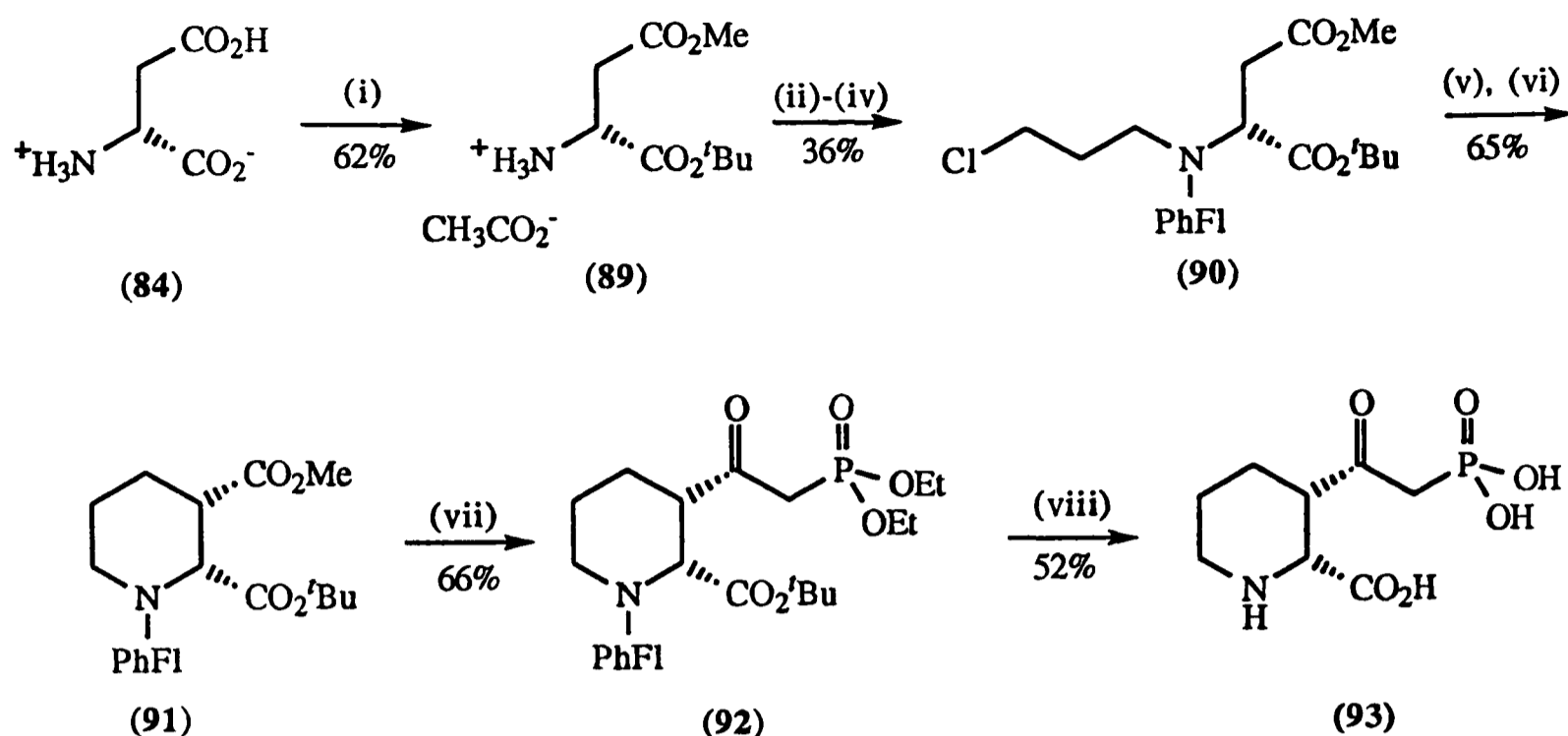

- (i) MeOH, SOCl₂; (ii) CH₃CO₂C(CH₃)₃, HClO₄; (iii) Br(CH₂)₃Cl, NaHCO₃;
 (iv) PhFI, Pb(NO₃)₂, ⁱPr₂EtN; (v) NaI; (vi) LDA, 2,6-diisopropylphenol;
 (vii) (EtO)₂POCH₂Li; (viii) TFA, TMSI, propylene oxide, MeOH.

Scheme 17

The synthesis of the γ -keto- α -amino acid (95), a potential intermediate in the synthesis of the novel sweet-tasting compound monatin (94) obtained from the roots of the plant *Schlerochiton illicifolius* has recently been reported by Holzapfel and Olivier, Scheme 18.⁵⁴ Two approaches to (95) that involve the coupling of a suitably protected indole acetate anion to an aspartic acid derivative such as (97) were investigated. In the first approach, the LDA generated anion of (96) was reacted with the anhydride (97) to afford the coupled products which were subjected to hydrogenolysis in the presence of Pd/C followed by treatment with diazomethane to furnish the isomeric esters (98) and (99). The selectivity of attack of the anion on the two carbonyls of the anhydride (97) was strongly dependent on the nature of the protecting group on nitrogen. Even at best, the ratio in favour of the desired γ -keto- α -amino acid derivative was only 50:50 with a yield of 35% of (98) being achieved over the three steps, Scheme 19. A similar approach was adopted by Melillo in his synthesis of the amino acid derivative (102), a potential intermediate in the synthesis of dopamine agonists, Scheme 20.⁵⁵ In Holzapfel's second approach to (95) the anion of (103) was reacted with acid chloride (104) available in a four steps from (*L*)-aspartic acid.^{54,56} Again a modest 55% yield (based on acid chloride) of (105) was obtained.

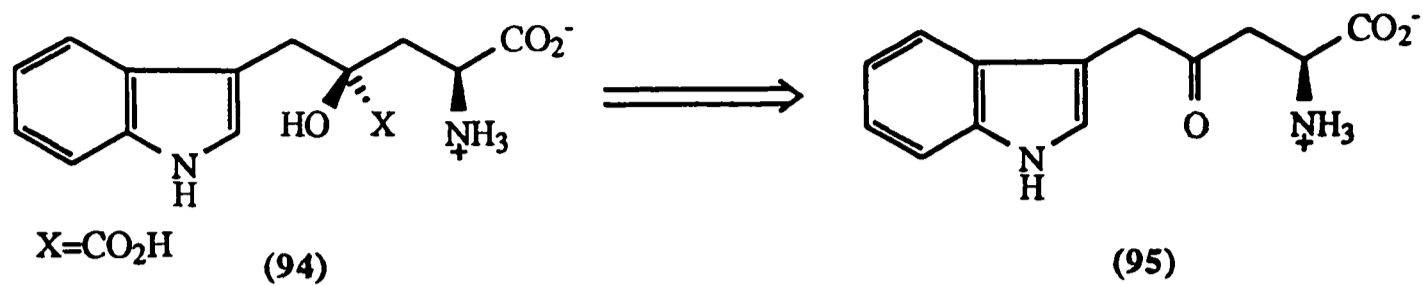

Scheme 18

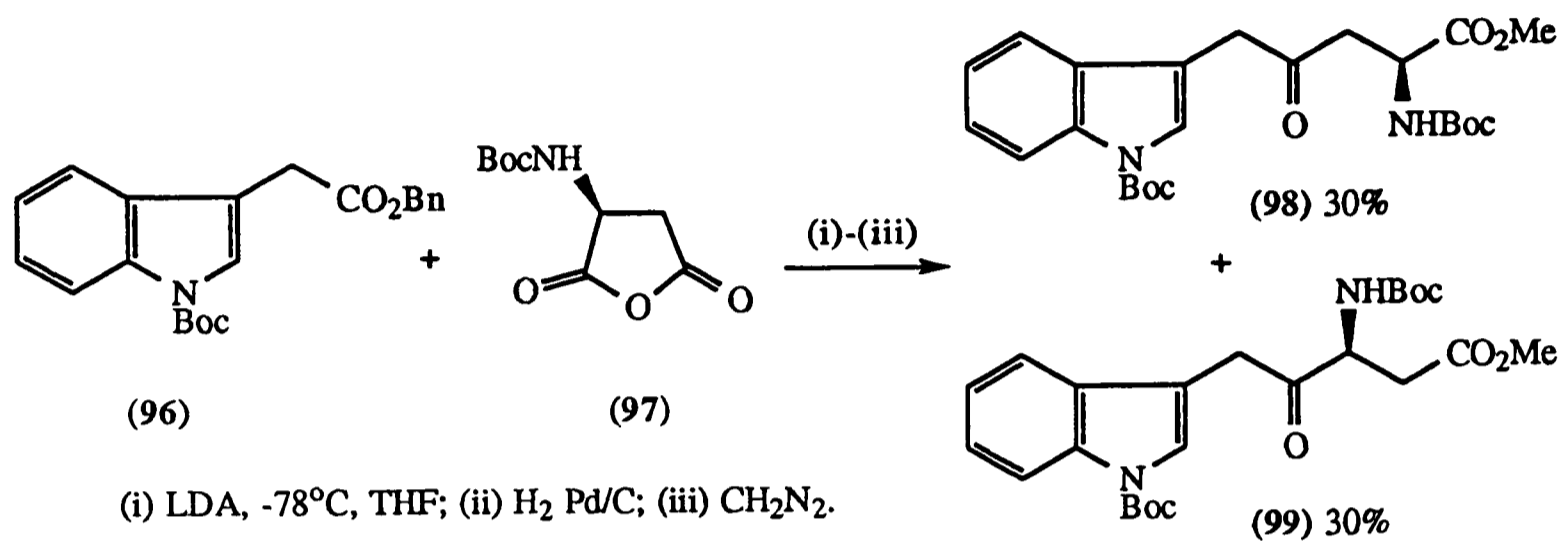

Scheme 19

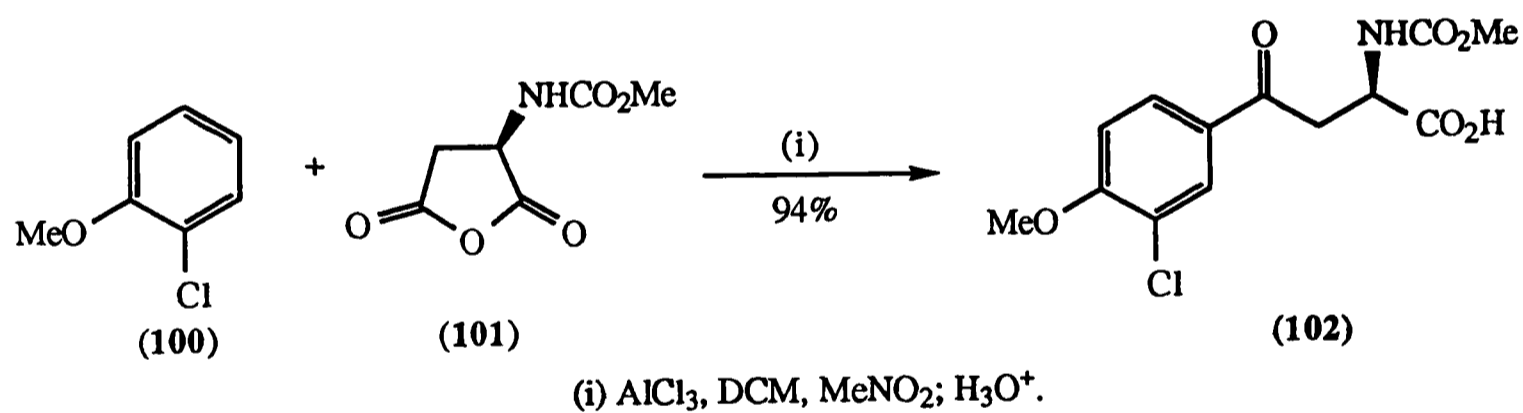

Scheme 20

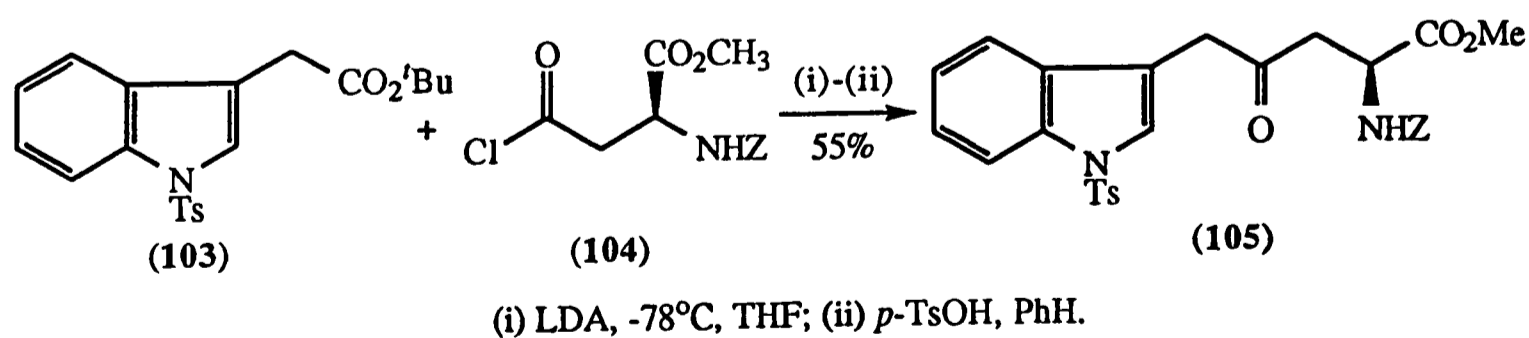

Scheme 21

Burger has recently reported the the synthesis of γ -keto- α -amino acids including (110) and (-)-HON (42) using a novel protecting group strategy.^{57,58} Hexafluoroacetone

and (*L*)-aspartic acid react to generate (107) thus achieving a selective protection of the α -amino group and carboxylic group in just one synthetic transformation. The ω -carboxylic acid remained unaffected and could be derivatised regioselectively. Conversion of (107) to the acid chloride (108) was accomplished using thionyl chloride and using Friedel-Crafts conditions was converted to a number of aryl ketones *e.g.* (110), Scheme 22. Treatment of (108) with diazomethane, however generated diazoketone (111). Decomposition of (111) with carboxylic acids gave fully protected (-)-HON (42). The formyl group was found to be superior to other O-protective groups and (111) was deprotected using water/isopropanol, giving (42) in an overall yield of 35% from (*L*)-aspartic acid, Scheme 23.

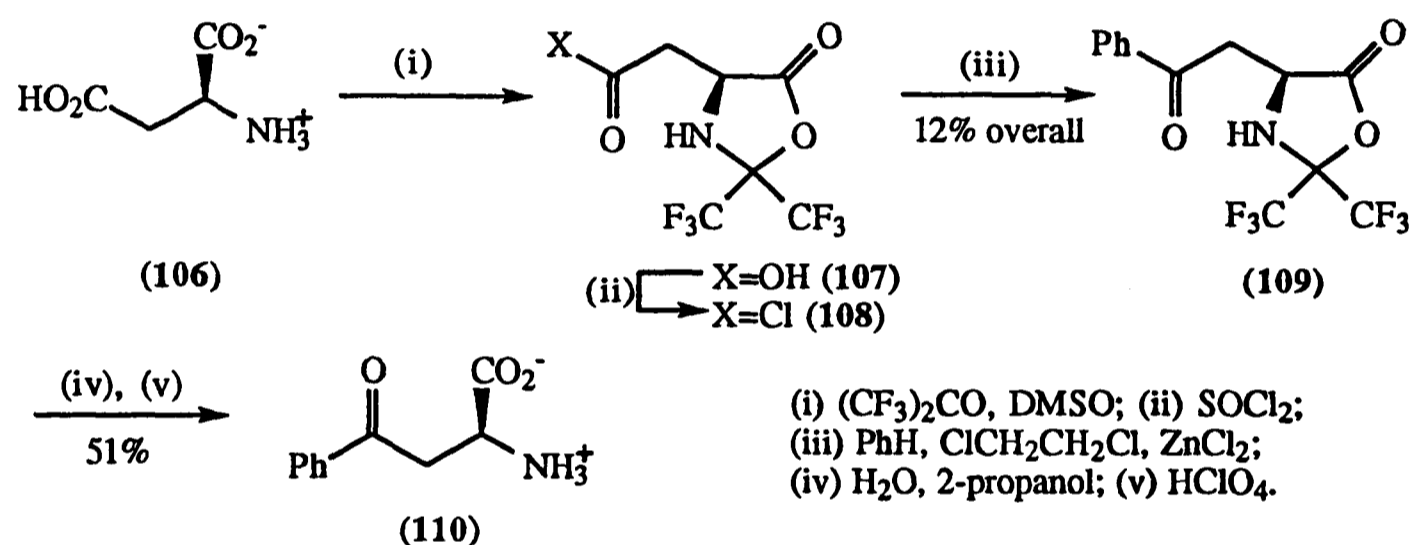

Scheme 22

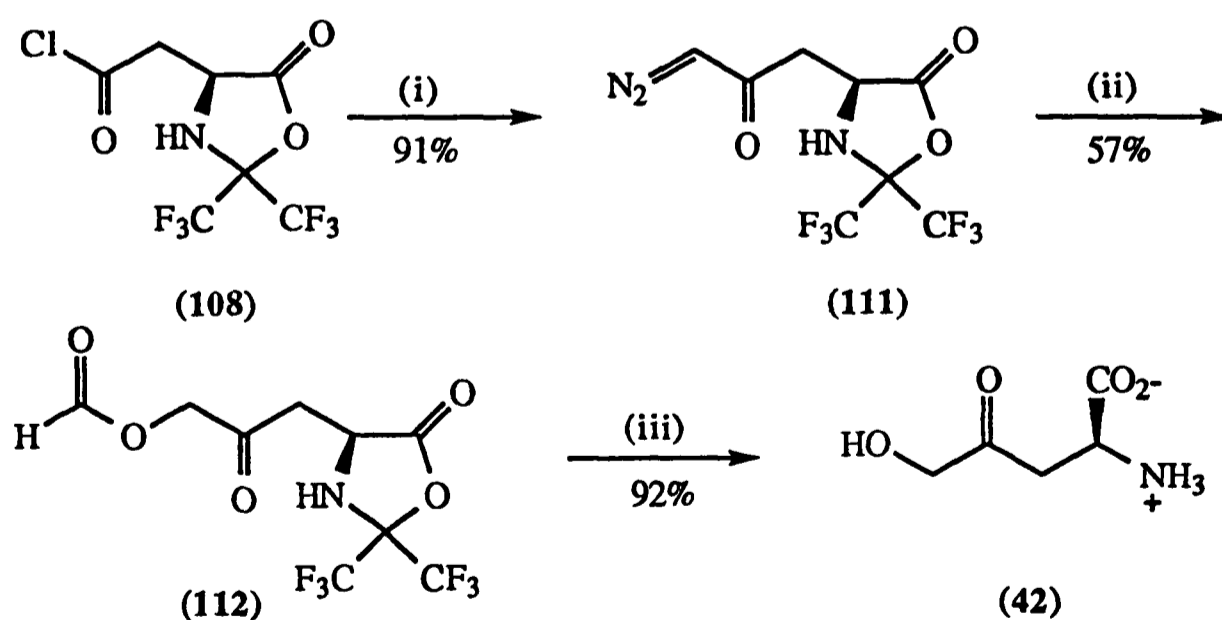

Scheme 23

A number of syntheses of kynurenine have been reported (see Section 8.2).⁵⁹⁻⁶³ Salituro's synthesis, which is flexible with respect to the preparation of analogues, involves a palladium-catalysed cross-coupling of stannane (114) and acid chloride (117) generating (115) which is deprotected to (116), Scheme 24.⁶⁴

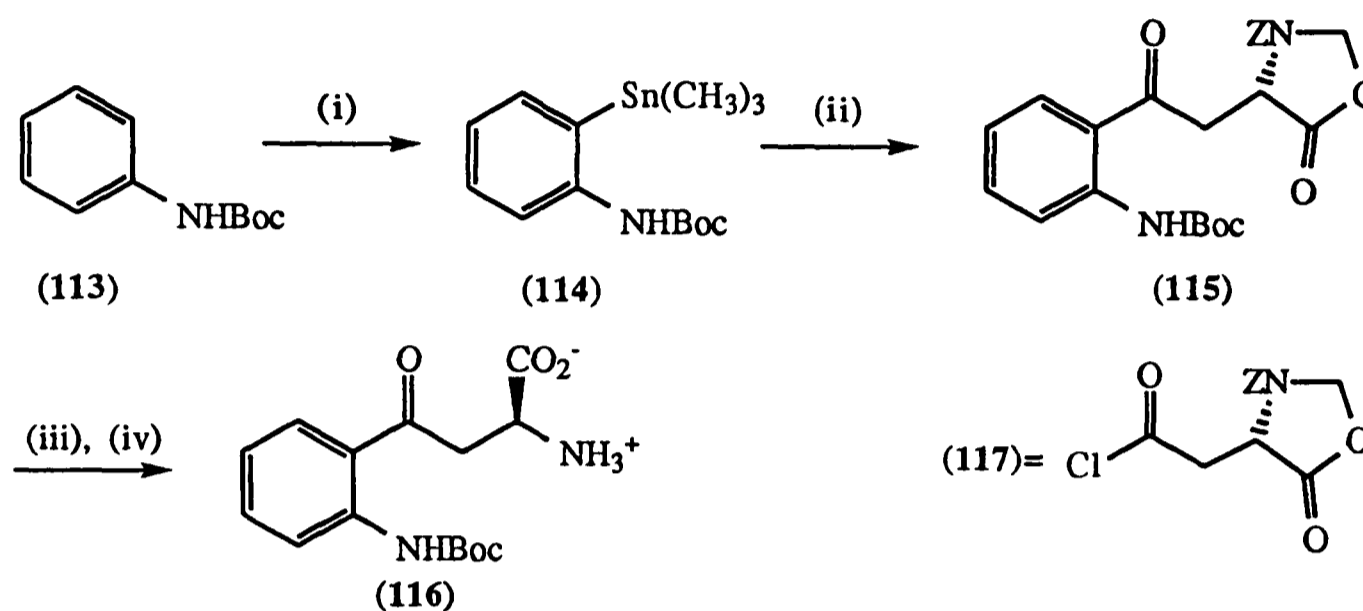

(i) $t\text{BuLi}$, $(\text{CH}_3)_3\text{SnCl}$; (ii) (117), $\text{Pd}_2(\text{DBA})_3 \cdot \text{CHCl}_3$, toluene, reflux;
 (iii) 30% HBr, HOAc; (iv) propylene oxide.

Scheme 24

9.3.4 Application of a β -alanine Anion Equivalent

Jackson *et al.* have reported the synthesis of a number of enantiomerically pure protected (*L*)- γ -keto- α -amino acids by coupling of the organozinc reagent (119), prepared in four steps from (*L*)-serine, with acid chlorides in the presence of *bis*(triphenylphosphine)palladium dichloride as catalyst. The synthesis of a protected derivative of (-)-HON (121) was achieved by reacting (119) with acetoxyacetyl chloride.^{65,66} The protecting groups, were however, not removed, Scheme 25.

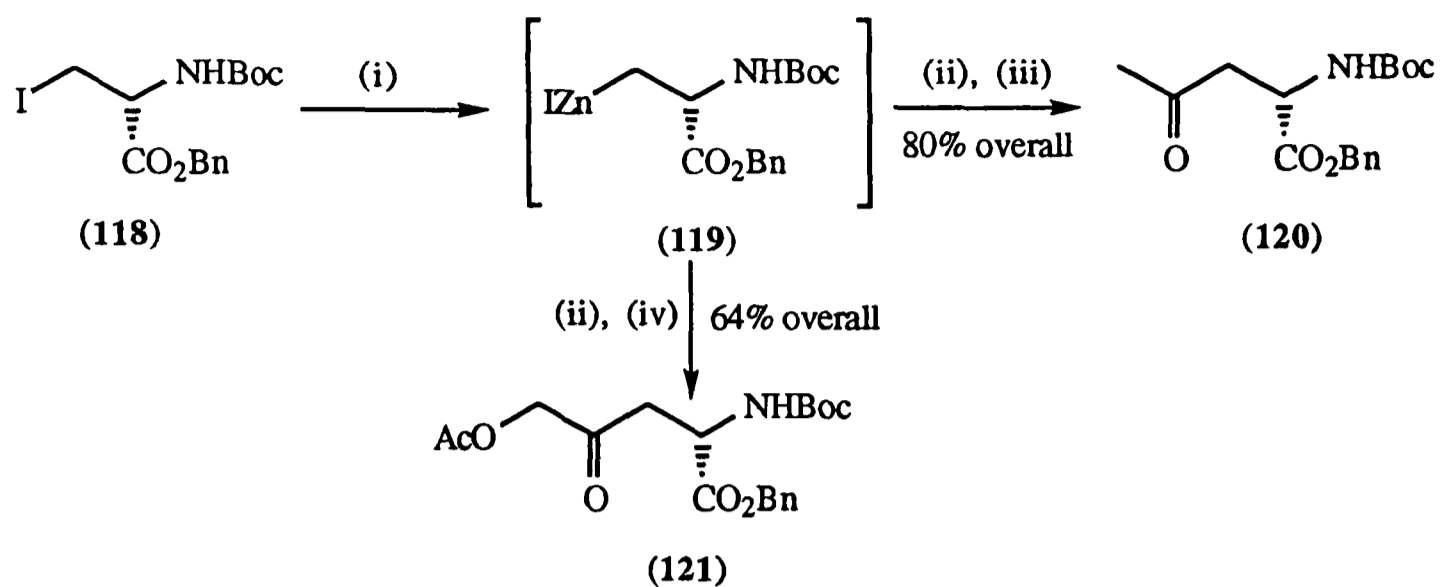

- (i) Zn/Cu couple (1.7eq.), PhH: dimethylacetamide (15:1), sonication, 20°C to 35°C, 30min.;
(ii) (Ph₃P)₂PdCl₂ (5 mol. %); (iii) MeCOCl (1 eq.), sonication, 35°C to 40°C, 30min.;
(iv) AcOCH₂COCl (1 eq.), sonication, 35°C to 40°C, 30min.

Scheme 25

Chapter 10

Carbon Based Nucleophilic Ring Opening of Activated Monocyclic β -lactams; Synthesis and Stereochemical Assignment of the ACE Inhibitor WF-10129

10.1 The β -lactam as a Chiral Synthron

The first synthesis of a β -lactam (or 2-azetidinone) (122) was reported by Staudinger as early as 1907.⁶⁷ These four membered ring heterocycles then remained little more than a curiosity until the discovery and structural elucidation of the penicillin antibiotics in the 1930's and 1940's.⁶⁸ The phenomenal success of the penicillins *e.g.* penicillin G (123), Figure 14, and related bicyclic β -lactam antibiotics *e.g.* cephalosporins, cephamycins, bleomycins, norcardicin, clavulanic acid and thienamycin as life-saving drugs has, more recently, led to extensive research in both industry and academia into the synthesis and reactivity of this moiety.

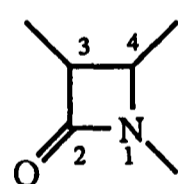

(122)

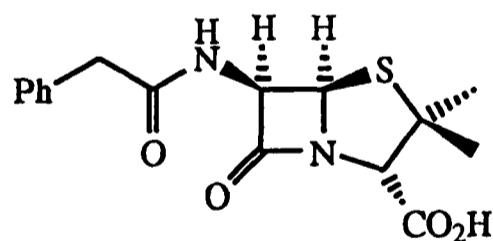

penicillin G (123)

Bond cleavage:
 C2-C3: strategy a; C3-C4: strategy b;
 N1-C4: strategy c; N1-C2: strategy d.

Figure 14

Many highly efficient and stereospecific syntheses of multifunctional β -lactams are now available which include, *inter alia*, the cyclisation of a functionalised β -amino acid,⁶⁹ the cyclo-addition of a ketene and an imine,⁷⁰ the reaction of an imine with a chromium carbenoid complex,⁷¹ the condensation of an ester enolate and an imine^{72,73} and the

cyclisation of β -amino ironacyl complexes.⁷⁴ As these methods have been well documented elsewhere they will not be discussed in detail here.

The strained four membered ring of monocyclic β -lactams renders these fascinating molecules powerful synthetic building blocks as well as useful intermediates in the synthesis of the bicyclic β -lactam antibiotics. Suitably substituted β -lactams can be converted into a variety of compounds, that are otherwise difficult to synthesise *via* the application of ring cleavage strategies. The potential of β -lactams for generating valuable synthons has been reviewed recently by Manhas^{75,76} and by Ojima⁷⁷ and thus the following discussion will be a brief overview of the possible modes of reaction of this ring system.

Opening of the β -lactam ring can occur through cleavage of any of the single bonds of the four membered heterocycle, Figure 14. *N*-Carboxyanhydrides have been obtained, for example, by cleavage of the C2-C3 bond (strategy *a*, Figure 14) either by peracetic oxidation of azetidin-2-diones,⁷⁸ Scheme 26 or ozonolysis of α -ethylidene-2-azetidinones.⁷⁹

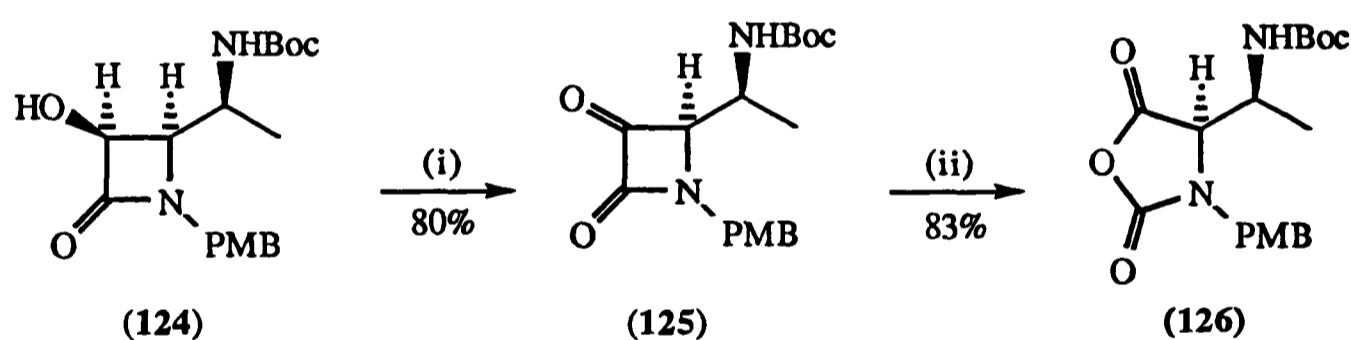

(i) P₂O₅, DMSO, 16h., RT; (ii) *m*-CPBA, DCM, -40°C, 1h.

Scheme 26

Bose has demonstrated that 3,3-diphenyl-4-amino β -lactams *e.g.* (127) undergo C3-C4 bond cleavage (strategy *b*, Figure 14) in the presence of water to give substituted amides *e.g.* (129). This transformation is proposed to proceed *via* the mechanism indicated in Scheme 27.⁸⁰ A tandem C3-C4 bond cleavage-rearrangement of 4-acyl or 4-imino-3,3-dimethoxy-2-azetidinones promoted by SnCl₂·2H₂O, Scheme 28, has recently been reported by Alcaide *et al.*⁸¹

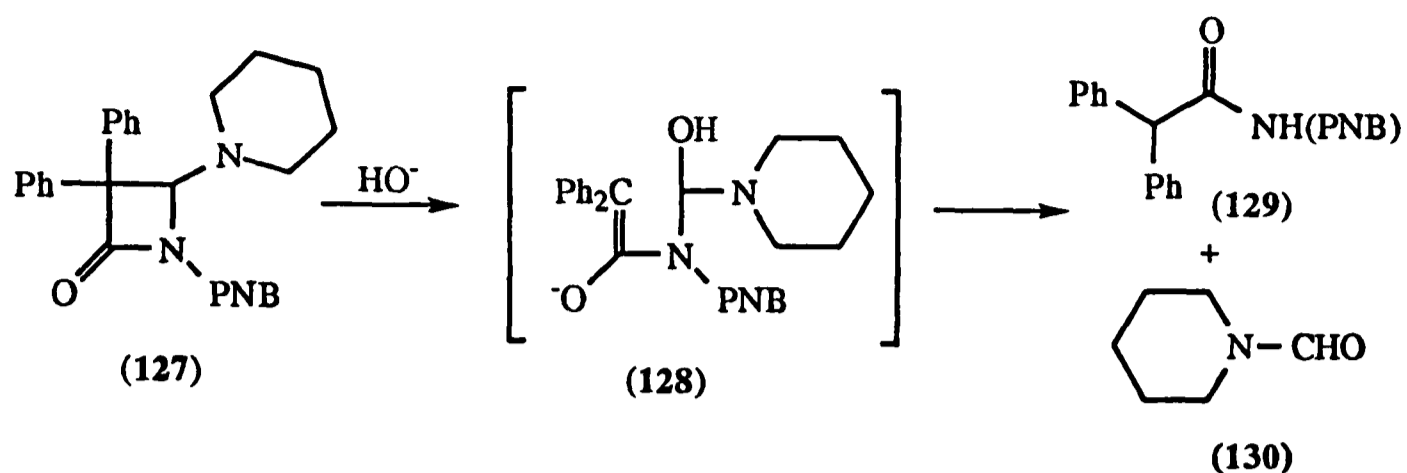

Scheme 27

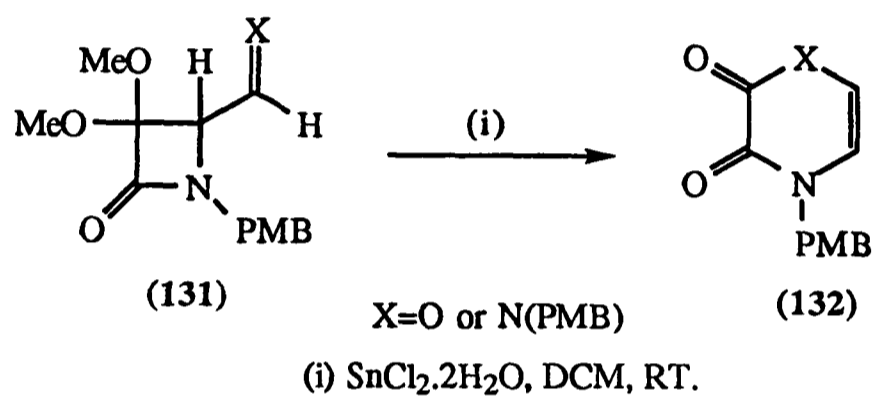

Scheme 28

C4-N1 bond breakage (strategy *c*, Figure 14) has been observed when β -aryl β -lactams *e.g.* (133) are subjected to palladium-catalysed hydrogenation or metal-ammonia reduction to provide dipeptides such as (134), Scheme 29. This methodology has proved extremely useful in the synthesis of α -amino acids, secondary amines, α -hydroxy acids and peptides.^{77,82}

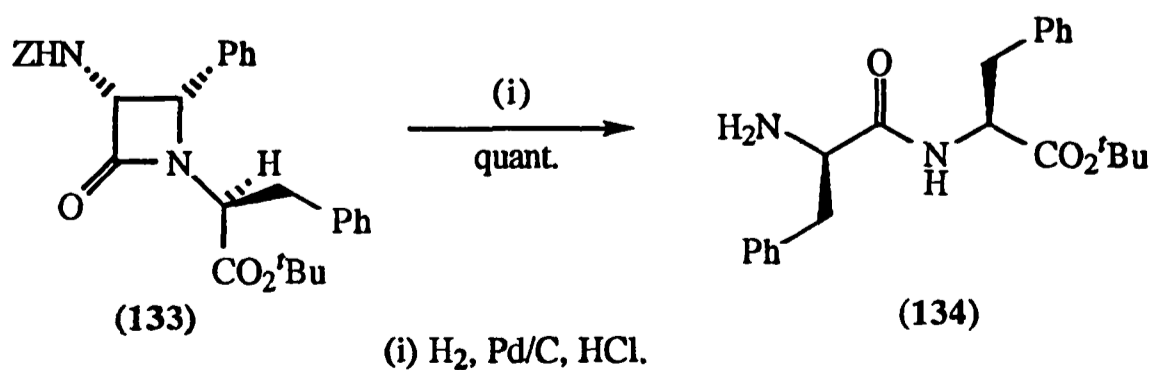

Scheme 29

Fission of the amide bond C2-N1 (strategy *d*, Figure 14) by nucleophilic reagents including water is the most well-known process and has been the subject of many investigations. This cleavage type has allowed for the synthesis of, *inter alia*, naturally occurring antibiotics, alkaloids, non- β -lactam heterocycles, carbohydrates, amino acids and peptides.^{75,76,82} Amide bond cleavage of β -lactam (137), synthesised by Ojima,⁸³ has, for example, proved useful in the total synthesis^{84,85} and semi-synthesis⁸⁶ of taxol (136), a complex diterpene isolated from the bark of *Taxus brevifolia* (Pacific Yew). Taxol is currently considered to be the most exciting lead in cancer chemotherapy. The C-13 side chain has been shown to be essential to the strong antitumour activity and the most efficient method for its coupling, developed by Holton,^{87,88} involves the reaction of the alkoxide of a protected form of (135) with (137), Scheme 30.

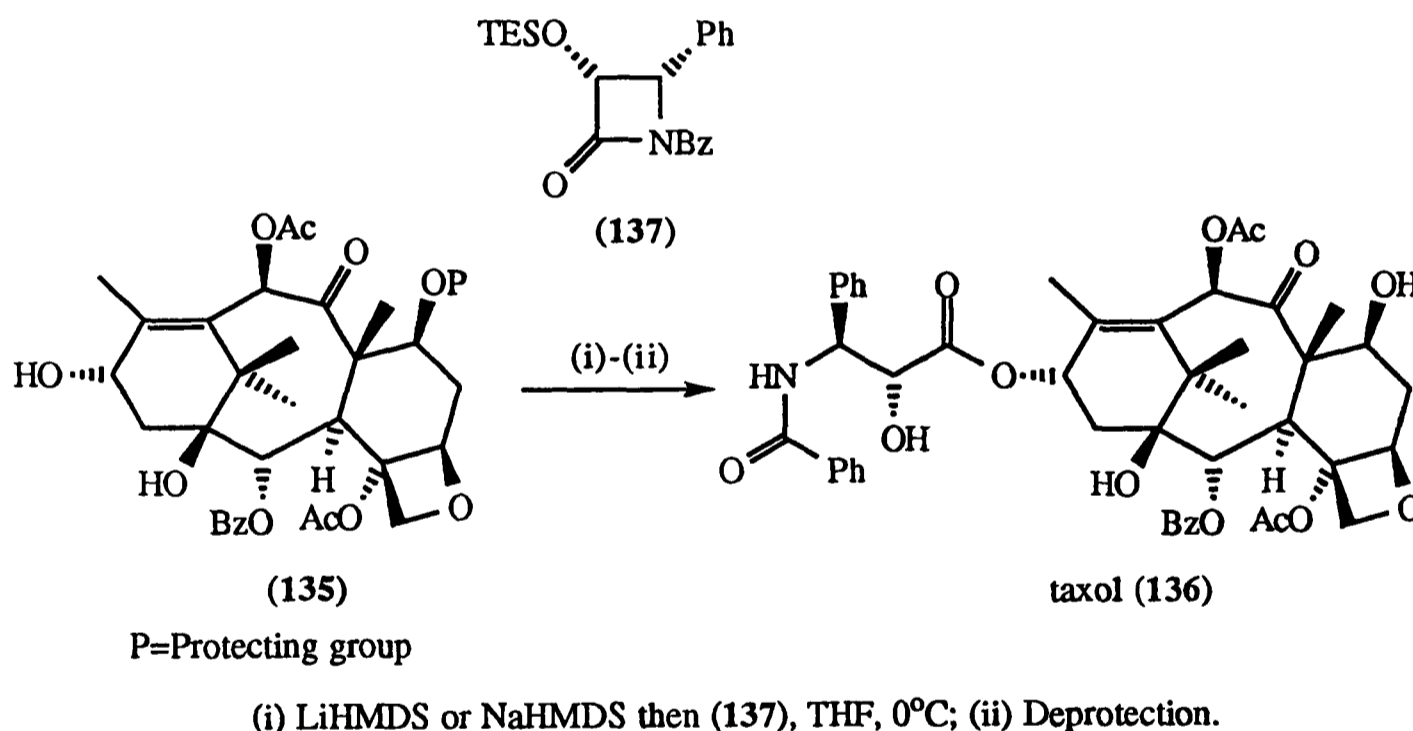

Scheme 30

To allow for the facile cleavage of the amide bond it is often necessary to activate the β -lactam carbonyl toward nucleophilic attack by employing an electron withdrawing group on nitrogen. In many cases mesomerically electron withdrawing groups *e.g.* carbamates are required to further restrict the resonance contribution of the nitrogen lone pair. The proposal that such a group can render the β -lactam carbonyl more ketone-like rather than amide in character is exemplified by the reaction of (138) and (139) with stabilised phosphorous

ylides, Scheme 31. Whereas the reaction of (138), a *N*-Boc derivative, affords the Wittig products *e.g.* (141) in good yield, no reaction of (139) was observed under similar conditions. Attempts to react (138) with unstabilised ylides led to decomposition.⁸⁹

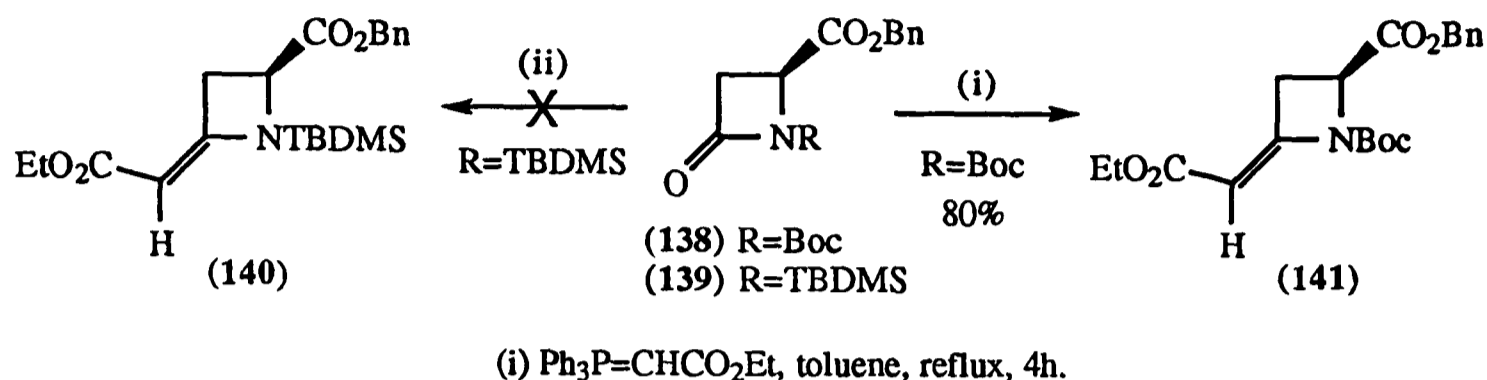

Scheme 31

Although the nucleophilic ring opening of monocyclic β -lactams, *via* cleavage of the amide bond, with heteroatom based nucleophiles has received much attention in the literature^{77,90-92} at the onset of this work only one report existed on the ring opening of β -lactams with carbanions. Kano *et al.* described the cleavage of the simple β -lactam (142) with alkyl and aryl lithium reagents in fair to good yield, Scheme 32. The scope of this reaction appeared to be limited to β -lactams in which there are no strongly acidic protons. Thus, the development of new methodology for the ring opening of more highly substituted β -lactams with other less basic carbanions could potentially lead to the preparation of synthetically useful compounds. The use of less basic carbanions was, for example, proposed to reduce the problems associated with the racemisation of α -amino acid centres through deprotonation, reprotonation sequences.

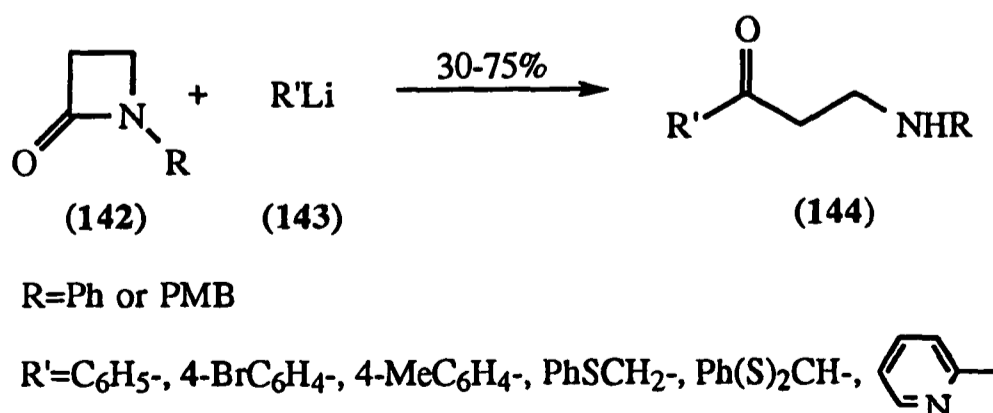

Scheme 32

10.2 Synthesis of γ -Keto- α -Amino Acids *via* Carbon Based Nucleophilic Ring Opening of Activated Monocyclic β -Lactams

10.2.1 β -Lactam Ring Opening with a Sulfur Ylide

The key element of our strategy for the preparation of the γ -keto- α -amino acid building block (34) of WF-10129 (20), Scheme 3, was to be the nucleophilic ring opening of activated monocyclic β -lactams such as (145) with carbon based nucleophiles. As β -lactam (145), derived from aspartic acid, is available as either enantiomer this met one of the initial stereochemical criteria, necessary for determining the absolute configuration of the natural product, Scheme 33.

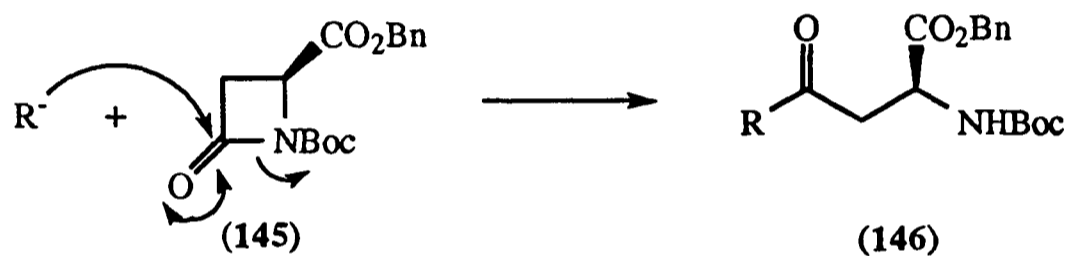

Scheme 33

The first approach to γ -keto- α -amino acid (34) intended to further develop some chemistry previously developed by the Baldwin group for the synthesis of γ -keto- α -amino acids. It had shown that the ring opening of the activated β -lactam (145) with sulfoxonium ylide (147) afforded the β -keto ylide (149), Scheme 34, the observed product arising from proton transfer in the zwitterionic intermediate (148). Ylide (149) is a highly functionalised intermediate which offered considerable opportunities for subsequent modification. Indeed, treatment of (149) with a number of reagents which either alkylated or protonated the stabilised ylide then nucleophilically displaced the sulfoxonium group were shown to provide a variety of functionalised γ -keto- α -amino acids.^{93,94} Attempts to ring open (145) with the more highly basic trimethylsulfonium ylide resulted only in decomposition. This result was in agreement with observations made during reactions with basic Wittig reagents, see Scheme 31 above.

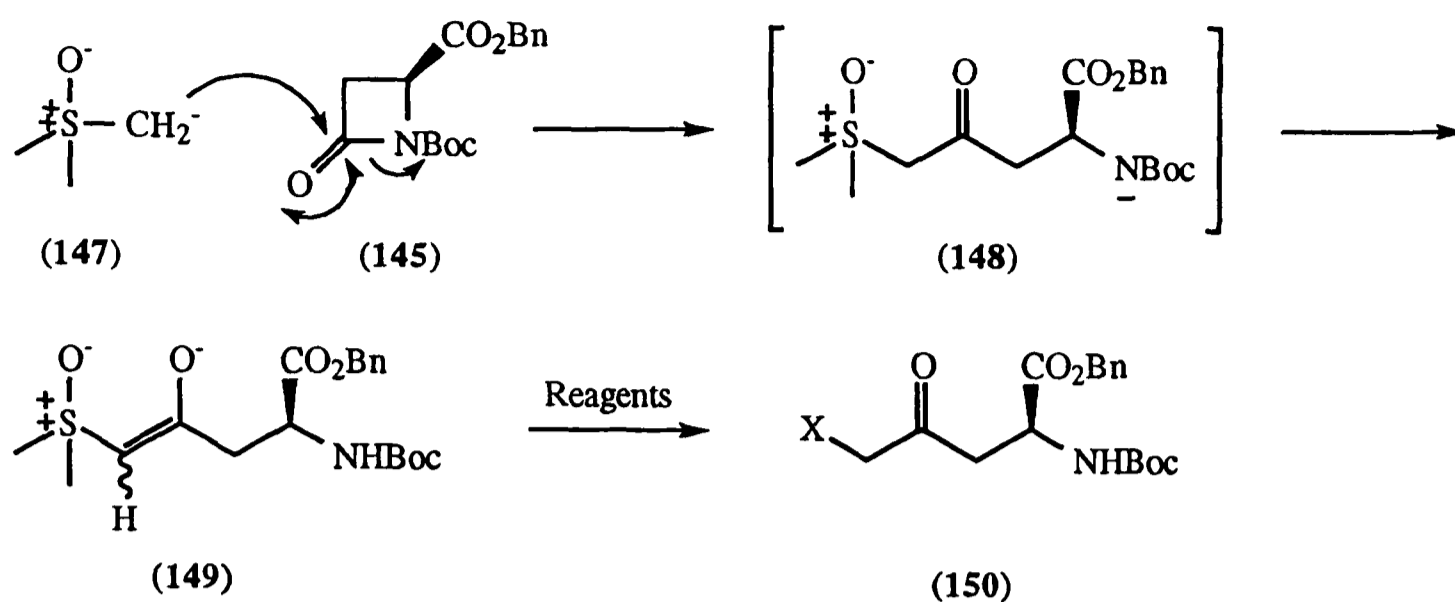

Scheme 34

The incorporation of δ -heteroatoms was particularly successful. Treatment of (149) with hydrogen chloride in acetic acid, for example, afforded the biologically active (*S*)-2-amino-4-oxo-5-chloropentanoic acid (43) (section 9.2), Scheme 35.^{93,94}

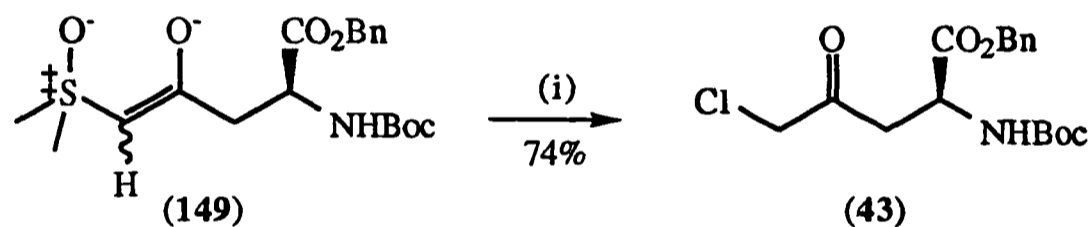

(i) 1M HCl, AcOH (1 eq.), DMF.

Scheme 35

An enantioselective synthesis of (-)-HON (42) (section 9.2) was also accomplished. Treatment of (149) with 47% hydrobromic acid in DMF afforded a mixture of (151) and (152).^{93,94} The crude hydroxy ketone (152) was converted to formate (151) by treatment of the reaction mixture with acetic formic anhydride in pyridine giving an overall 62% yield of (151). Deprotection in two steps then afforded (42) as the hydrochloride salt.

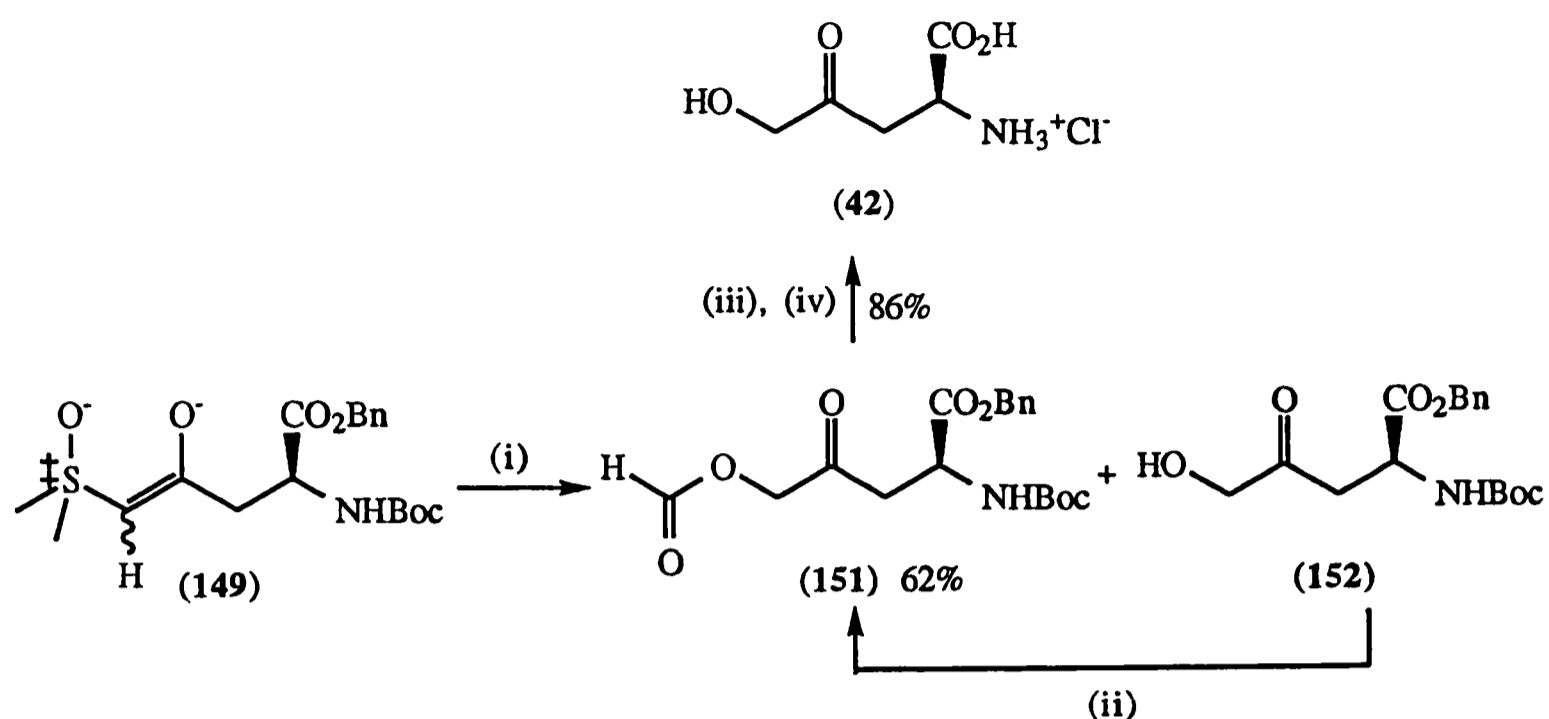

(i) HBr (aq.), DMF, 50°C; (ii) AcOCHO, pyridine; (iii) H₂, 10% Pd/C; (iv) HCl, dioxane.

Scheme 36

In order to prepare γ -keto- α -amino acid (34) it was intended to react (149) (or its *R*-enantiomer) with an appropriate alkylating species with either concomitant or subsequent removal of the sulfur group depending on the nature of the electrophile. As the stereochemistry at the carboxyl centre of (34) was most likely to be *S* *i.e.* the same stereochemistry found in the synthetic ACE inhibitors enalapril and lisinopril (Chapter 8), the β -lactam (4*S*)-benzyl azetidin-2-one-4-carboxylate (156) was initially prepared. Thus, (*L*)-aspartic acid was converted to (*L*)-aspartic acid dibenzyl ester *p*-toluenesulfonate (153)⁹⁵ which was extracted (K₂CO₃/EtOAc) to provide the free amine (154). β -lactam closure was accomplished using a modification of Salzmann's procedure involving the *t*butyl Grignard mediated cyclisation of (*L*)-*N*-trimethylsilyl dibenzyl aspartate prepared *in situ*.^{94,96-98} The labile TMS group was then lost on acidic work-up to afford (156). Degradation studies have indicated that ring closure occurs with complete retention of configuration at C-4.⁶⁹

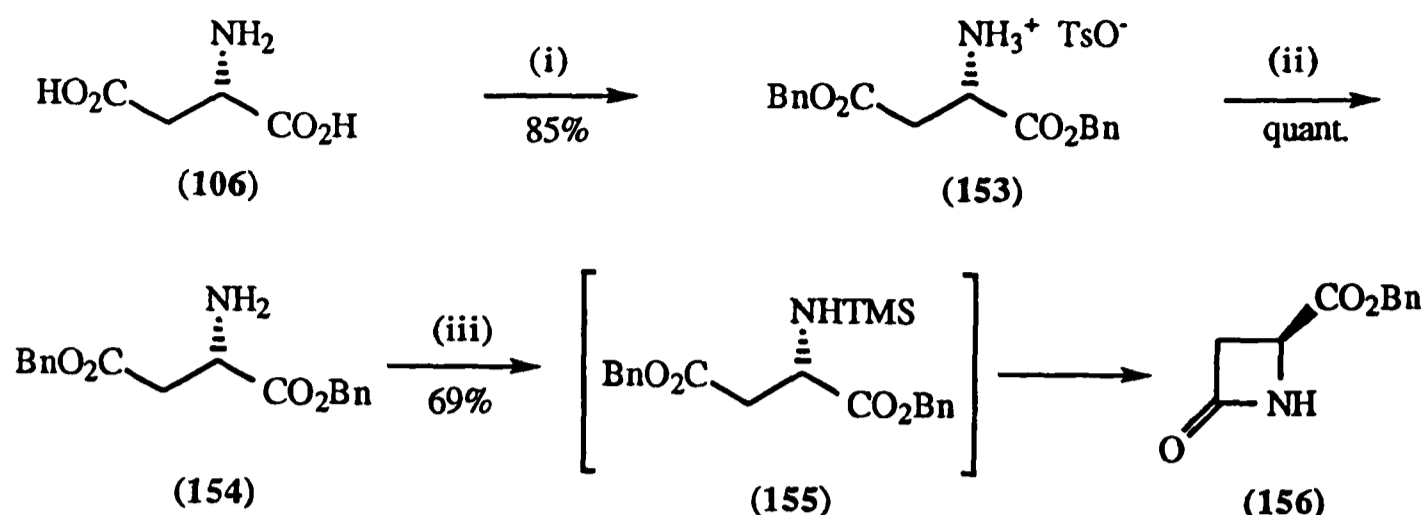

Scheme 37

The β -lactam was simultaneously protected and activated towards nucleophilic attack by formation of the *N*-Boc β -lactam (145)⁹⁸ which was subsequently converted to the acyclic α -ketosulfoxonium ylide (149) with the sodium salt of trimethylsulfoxonium iodide in near quantitative yield. Spectroscopic analysis indicated that of the possible resonance hybrids, (149) exists primarily in the enolic form indicated in Scheme 38, in agreement with reports on dimethylsulfoxonium phenacylide (157), Figure 15.^{99,100}

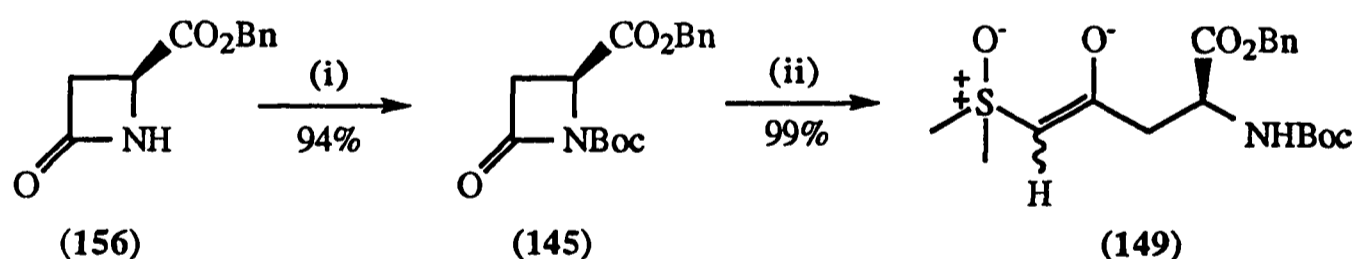

(i) Boc_2O (2 eq.), DMAP (0.1 eq.), MeCN, RT, 17h.;
 (ii) trimethylsulfoxonium iodide (1 eq.), NaH, DMSO, RT, 10min.

Scheme 38

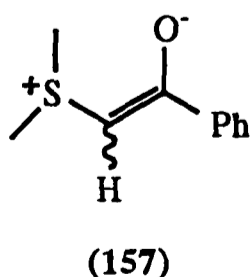
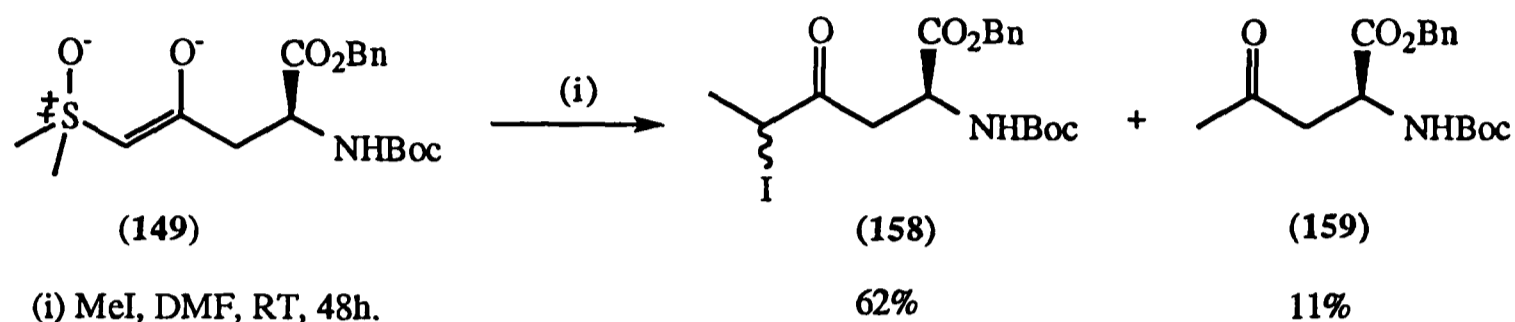
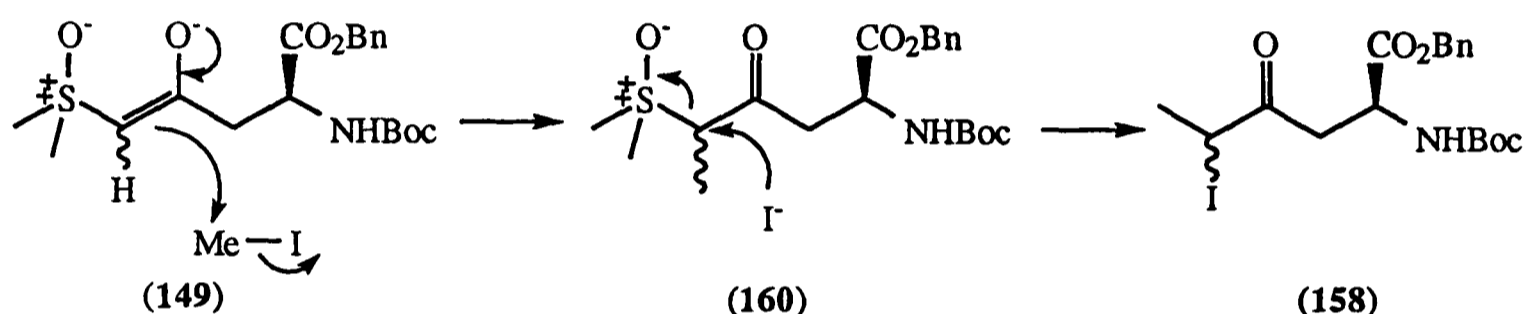

Figure 15

As part of preliminary model studies, alkylation of (149) was attempted with methyl iodide, Scheme 39.^{93,94} Stirring for forty-eight hours in a brown glass vessel and in the presence of metallic copper (to stabilise the methyl iodide) followed by flash chromatography afforded (158) and (159) in yields of 62% and 11% respectively. The two isomers of iodide (158) presumably arise as indicated in Scheme 40.



Scheme 39



Scheme 40

It is believed that side product (159) may arise from decomposition of methyl iodide which leads to the formation of hydrogen iodide that can activate ylide (149) by protonation. Nucleophilic substitution by iodide would then generate (162) but as (162) is not isolated it appears that an iodide mediated deiodination is occurring to afford methyl ketone (159), Scheme 41.

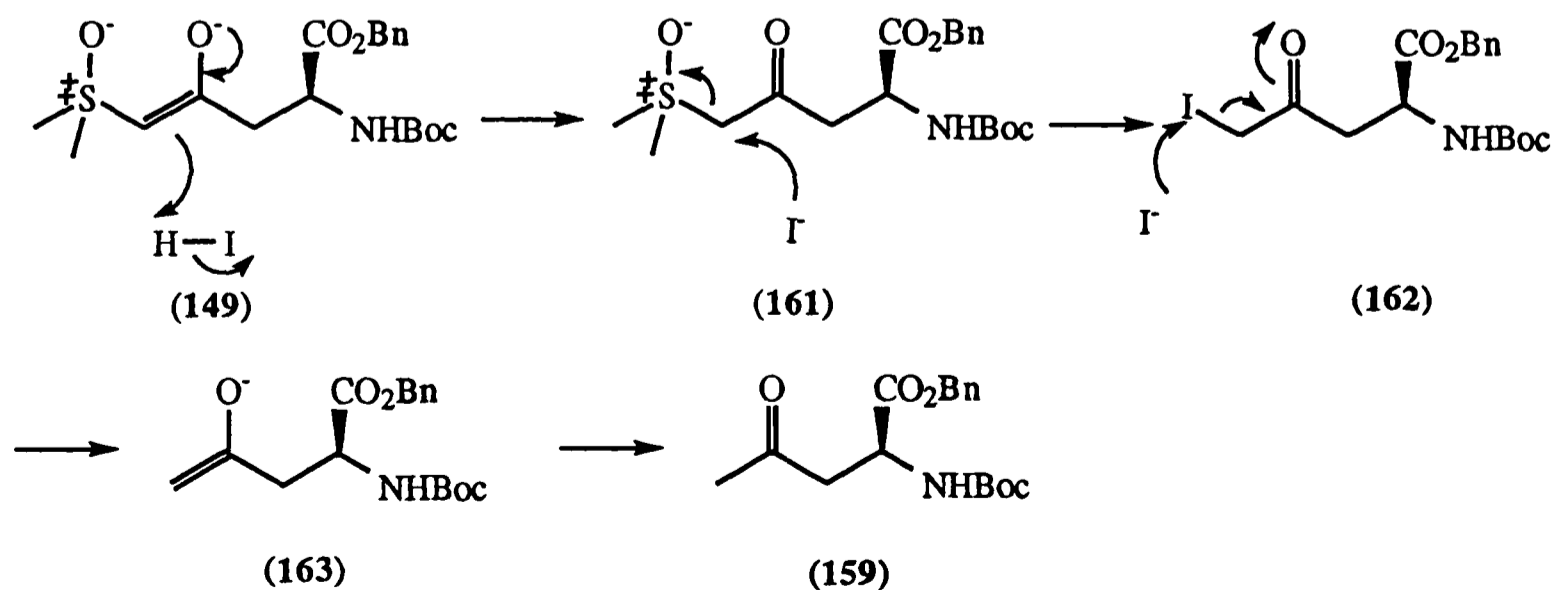

Scheme 41

In a separate experiment, the crude reaction mixture resulting from the treatment of (149) with methyl iodide was subject to a zinc/acetic acid reduction to afford ketones (164) and (159), Scheme 42. The optical integrity of the products of this sequence was then established by comparison of the specific rotation of (164) [$+14.0$ (c 1, CH_2Cl_2)], and (159) [$+13.9$ (c 1, CH_2Cl_2)] with the literature values of [$+13.4$ (c 1, CH_2Cl_2)], and [$+14.5$ (c 1, CH_2Cl_2)] respectively.⁶⁶

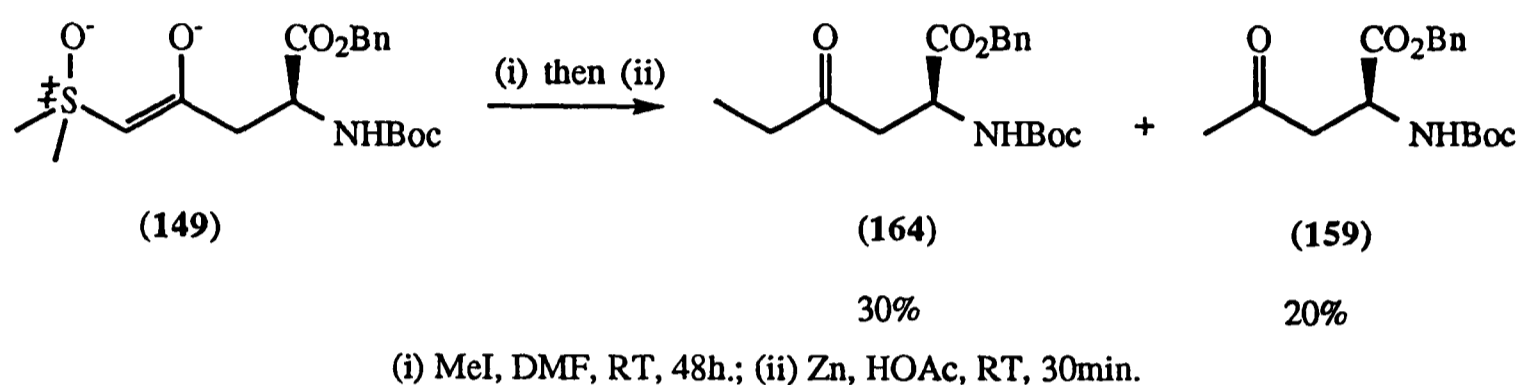

Scheme 42

In order to synthesise γ -keto α -amino acid (34) using this strategy it would be necessary to employ a primary β -branched iodide. Thus, as part of the model studies (149) was treated with iodide (165). Prolonged stirring of (149) with (165) at room temperature resulted only in the recovery of starting material (149) whereas warming of the mixture to 70-80°C led to the formation of a number of unidentifiable compounds, Scheme 43. From this and other results, for example with ethyl iodide,⁹⁴ it has become apparent that the homologation of ylide (149) with alkyl halides is rather limited in scope and alternative methods for the formation of (34) from (145) were therefore investigated.

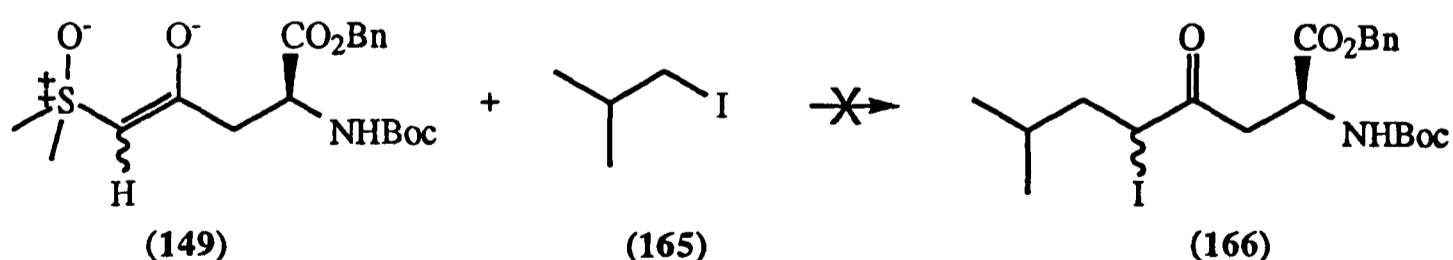

Scheme 43

It was hoped that (149) would behave as other stabilised enolates such as β -ketoesters and that alkylation by propylene oxide¹⁰¹ would be possible and generate alcohol

(167) (after proton transfer) which could be further elaborated to (34), Scheme 44. It was envisaged that the sulfur group may be removed by, for example, displacement with hydrogen iodide (followed by removal of the so-formed iodide with zinc/acetic acid). As propylene oxide is commercially available as either enantiomer its use would potentially allow for the formation of either diastereomer of (34) at the secondary alcohol centre, another of the necessary stereochemical criteria.

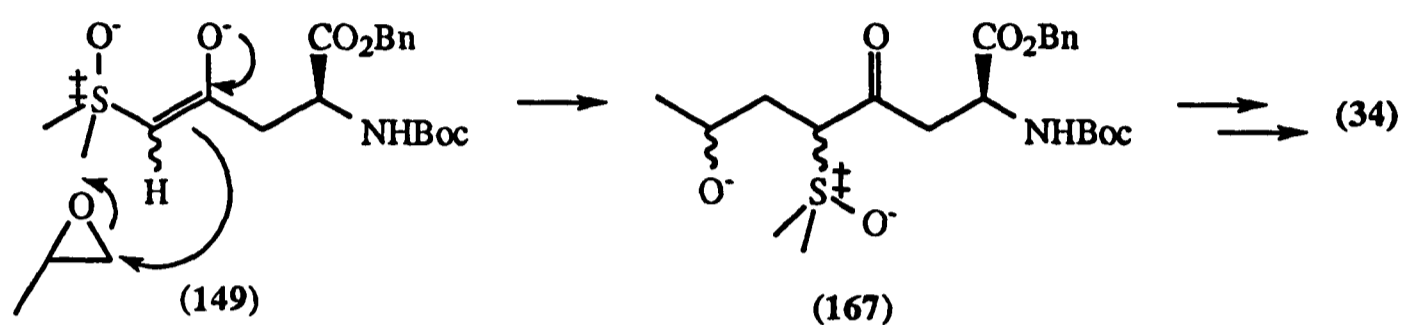

Scheme 44

In terms of literature precedent, the simple sulfoxonium ylide (168) has been reported to ring open a variety of epoxides such as (169), Scheme 45.¹⁰² However, unlike the corresponding reaction between lithiated sulfoxide (172) and propylene oxide which generates the γ -hydroxysulfoxide (173)¹⁰³ the alcohol was not obtained but rather oxetane (171), as a result of the nucleophilic displacement of the sulfur group by the alkoxide. Furthermore, the reaction between (168) and (169) was reported to be extremely slow and high yields of oxetane (171) were only obtained on using a large excess (100 eq.) of ylide (168), which would clearly be undesirable in our case.

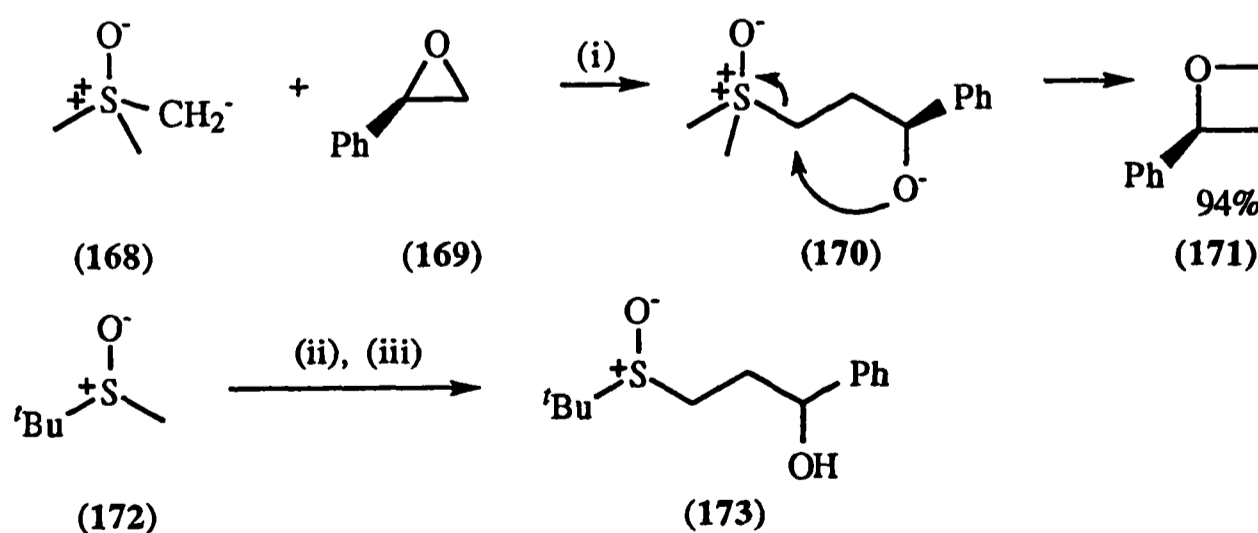

(i) 50°C, 3 days; (ii) MeLi; (iii) propylene oxide.

Scheme 45

If oxetane formation proved to be a problem with (149) and propylene oxide, it was envisaged that the alkoxide (167) may be reacted *in situ*. However, prolonged stirring of (149) and propylene oxide resulted only in the recovery of starting material (149), Scheme 46. Clearly, a more reactive alkylating species was required.

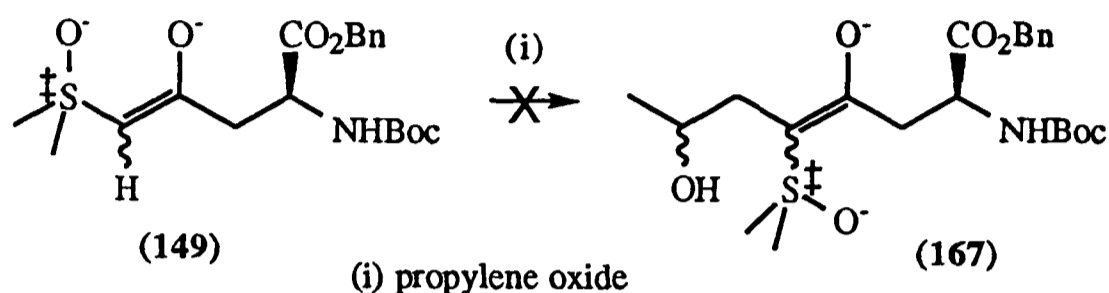

Scheme 46

1, 2-Cyclic sulfates such as (174) have been reported to behave like epoxides in that they undergo ring opening with nucleophiles. Generally the same regioselectivity is observed but they are, however, apparently always more reactive.¹⁰⁴⁻¹⁰⁶ Although the five membered ring is less strained than the three membered ring (5kcalmol⁻¹ vs. 27kcalmol⁻¹), their enhanced reactivity is believed to result from the better leaving group ability of the sulfate compared to an alkoxide.¹⁰⁶ Following ring opening, the sulfate group may be removed by acid hydrolysis to generate alcohol (176), Scheme 47.

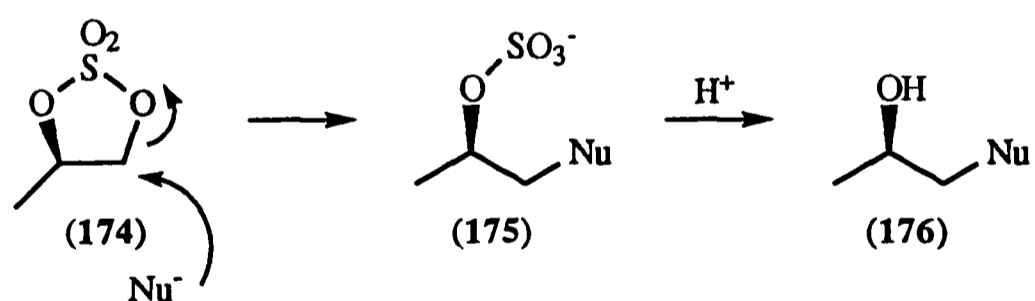

Scheme 47

Sharpless has recently developed an improved and facile conversion of 1,2-diols into cyclic sulfates^{107,108} which has led to the greater availability of this class of compounds in the optically pure form and consequently to their increased use as chiral synthons in organic synthesis. Thus, as (174) may also be prepared as either enantiomer it was decided to investigate its use in the preparation of γ -keto- α -amino acid (34), Scheme 3, as a more

reactive alternative to propylene oxide. Furthermore, as an alkoxide is not an intermediate oxetane formation was less likely to be problematic. Again, however, no reaction was observed between (149) and (174) at room temperature and decomposition occurred on warming the reaction mixture, Scheme 48. At this stage it was clear that ylide (149) was not sufficiently reactive to allow for the completion of the synthesis of WF-10129 (20) in this manner and thus alternative strategies were sought.

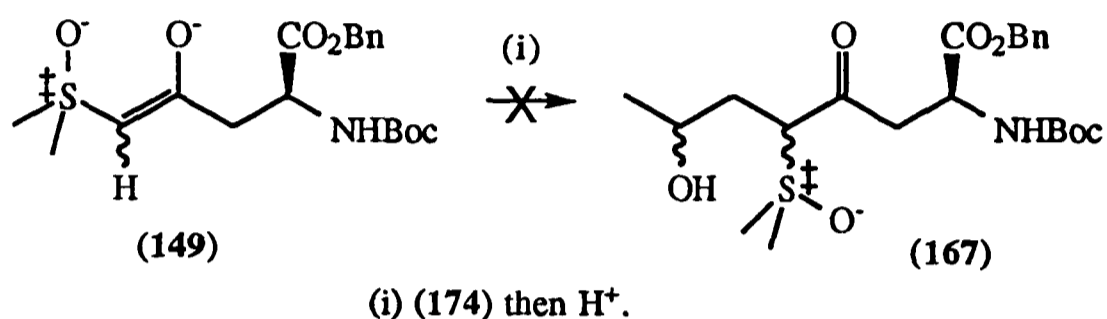

Scheme 48

10.2.2 β -Lactam Ring Opening with Lithiated Sulfones

Other methods by which γ -keto- α -amino acids could be prepared by the carbon based nucleophilic β -lactam ring opening reactions were investigated with firstly sulfone stabilised carbanions being examined in this rôle. The use of sulfones was appealing since it would allow for the construction of highly functionalised precursors for reaction with β -lactams such as (144) and with regard to WF-10129 (20) this would potentially facilitate the construction of the 6'-hydroxy side chain. Thus, methylphenylsulfone (178) was prepared by the potassium monoperoxysulfate (commercially available as a triple salt known as Oxone[®]) oxidation of thioanisole (177), Scheme 49.¹⁰⁹

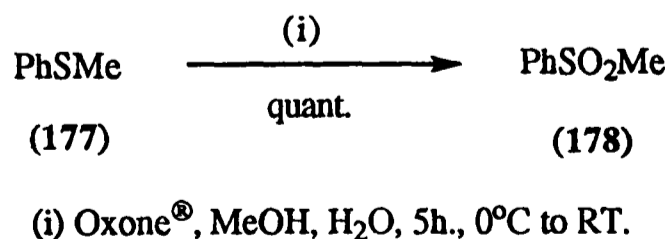

Scheme 49

Formation of carbanions from simple sulfones such as (178) is well documented and requires the use of strong bases.¹¹⁰ The requisite conditions for the successful reaction of the anion of (178) with β -lactam (145) were found to be prior lithiation of the sulfone with *n*-butyllithium followed by the addition of β -lactam (145) at -78°C . However, in addition to the desired β -lactam ring opening, attack of lithiated form of sulfone (178) at the benzyl ester of (145) was found to be a competing reaction as witnessed by the isolation of (180) and sulfone (181). The latter could not be purified due its co-elution with methylphenylsulfone in a variety of solvent systems during silica gel chromatography, Scheme 50.

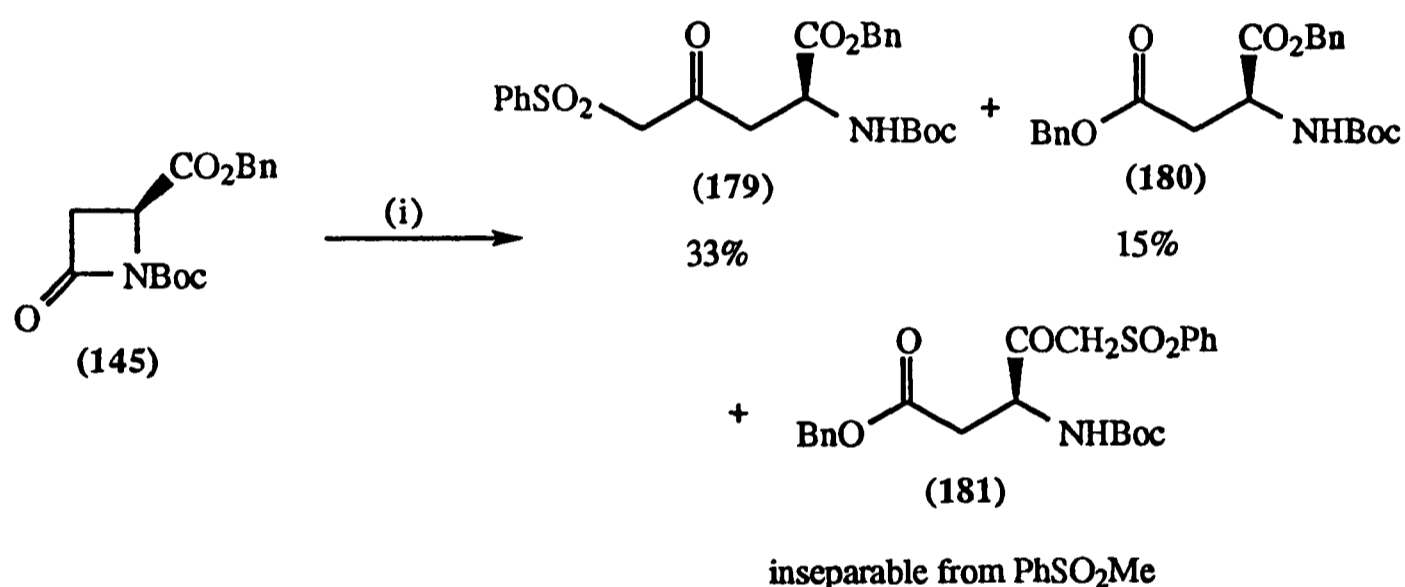

(i) PhSO_2Me (178) (1 eq.), *n*-BuLi (1 eq.), THF, -78°C , 30min. then NH_4Cl .

Scheme 50

The sulfone group may be selectively removed using any one of a variety of reagents. However, for β -keto sulfones aluminium amalgam is generally employed^{111,112} although its use with complex multifunctional systems is often problematic. A recent report has indicated that in cases where aluminium amalgam is ineffective, trialkyltinhydrides can act as efficient alternatives.¹¹³ The former, however, gave a high yield of methyl ketone (159) from (179) provided a large excess of amalgam was used, that the amalgam was freshly prepared under argon and the solvent (a 9:1 mixture of THF:H₂O) was degassed prior to the reaction, Scheme 51.

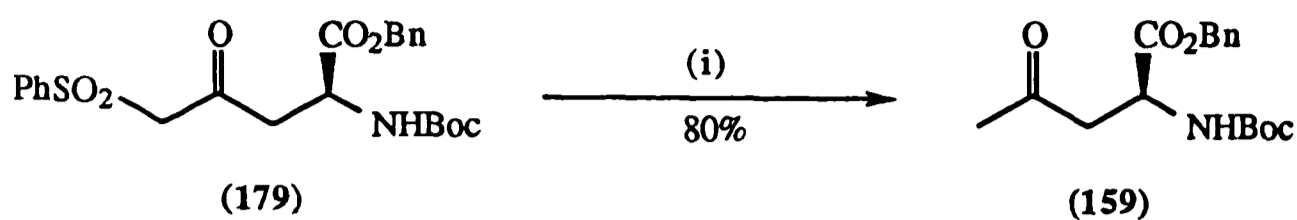

(i) Al/Hg, deoxygenated THF:H₂O 9:1.

Scheme 51

In order to reduce the possibility of attack of lithiated sulfone (178) on the benzyl ester, a more sterically demanding ester was required. The *t*-butyl ester was selected and accordingly (4*S*)-*t*-butyl *N*-(*t*-butoxycarbonyl)-azetidin-2-one-4-carboxylate (184) was prepared in three steps from (156), Scheme 52. Hydrogenolysis of (156) afforded the crystalline carboxylic acid (182) which was treated with *t*-butyl 2,2,2-trichloroacetimidate (Jackson's reagent)¹¹⁴ in the presence of Lewis acid to generate *t*-butyl ester (183) in a 75% yield. Due to the low solubility of the carboxylic acid (182) in neat cyclohexane (the preferred solvent for this reaction) it proved necessary to use THF as co-solvent. As Jackson's reagent is reported to be unstable in the presence of THF¹¹⁴ it was essential to keep the quantity to a minimum if a reasonable yield of *t*-butyl ester (183) was to be attained. Thus a THF/cyclohexane in a ratio of 2:3 (*ca.* 2.7ml per mmol (182)) was used in which, at the onset of the reaction, (182) was only partially dissolved. Following this, β -lactam (183) was activated toward nucleophilic attack by formation of its *N*-Boc derivative (184).

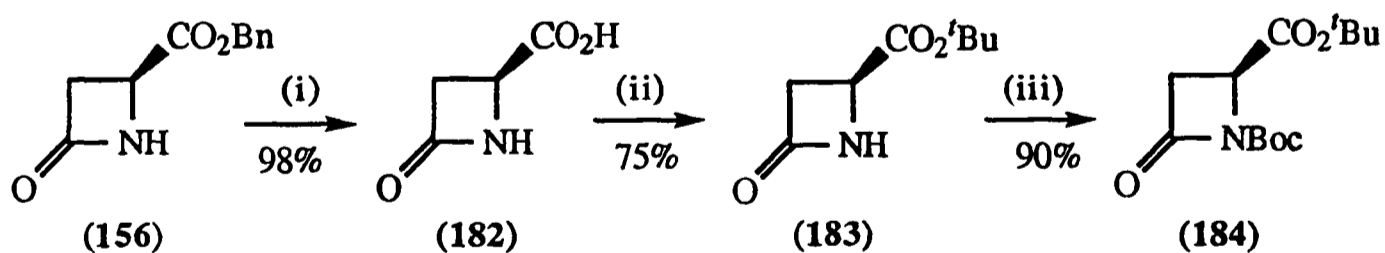

(i) H₂, 10% Pd/C, THF, 24h.; (ii) Cl₃CC=NH(O^{*t*}Bu) (2 eq.), BF₃·Et₂O (cat.), THF:cyclohexane 2:3, RT, 30min.; (iii) Boc₂O (2 eq.), DMAP (0.1 eq.), MeCN, RT, 24h.

Scheme 52

β -lactam (184) was found to exhibit the desired chemospecificity toward lithiated sulfone (178). However, with one equivalent of lithiated (178) a yield of only 48% of the

desired β -ketosulfone (185) was achieved along with a 45% recovery of starting material (184). It was proposed that the basicity of lithiated (178) was such that deprotonation of (187) to (188) occurred leading to incomplete reaction, Scheme 54. Further development demonstrated that by employing two equivalents of sulfone anion, the ring opening reaction could be driven to completion and a yield of 81% of (185) obtained. Furthermore, the unused equivalent of sulfone could be recovered by column chromatography. Once the sulfone group had served its purpose, it was reductively removed in high yield by treatment with aluminium amalgam to afford methyl ketone (186),¹¹² Scheme 53.

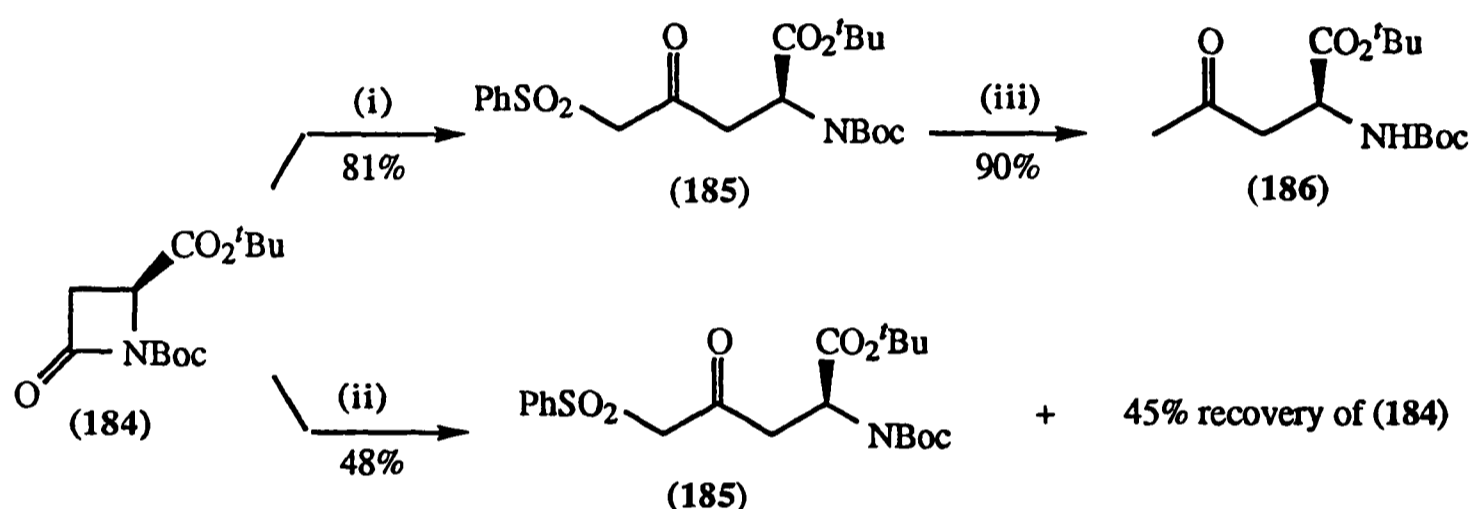

- (i) PhSO_2CH_3 (178) (1 eq.), $n\text{BuLi}$ (1 eq.), THF, -78°C , 20 min. then NH_4Cl ;
(ii) PhSO_2CH_3 (178) (2 eq.), $n\text{BuLi}$ (2 eq.), THF, -78°C , 20 min. then NH_4Cl ;
(iii) Al/Hg , deoxygenated THF: H_2O 9:1.

Scheme 53

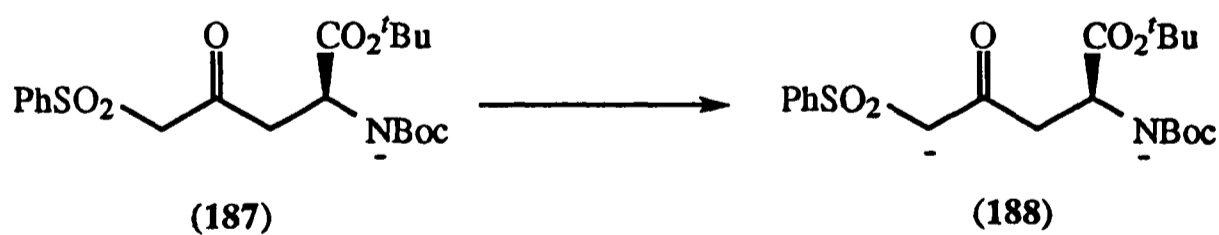

Scheme 54

With regard to the synthesis of γ -keto α -amino acid (34) two approaches were considered for the preparation of its 6' hydroxy side chain. Firstly, a lithiated form of ketosulfone (185) could be treated with propylene oxide or the more reactive 1,2-propane cyclic sulfate (174) in a comparable manner to that discussed for the ylide (149) (section 10.2.1). Alternatively, ring opening of the β -lactam could be attempted with a lithiated sulfone in

which the side chain was already in place. If the latter approach were to be adopted ring opening with a secondary anion would be required. Thus, further model studies were initiated to probe the reactivity of more hindered sulfone anions in this novel reaction. Ring opening of (184) with *n*-butylphenylsulfone (189) (prepared by the reaction of lithiated (178) with 1-iodopropane, Scheme 55) was attempted and found to be successful. The resulting β -ketosulfone (190) was subjected to aluminium amalgam reduction to generate γ -keto α -amino ester (191), Scheme 56.

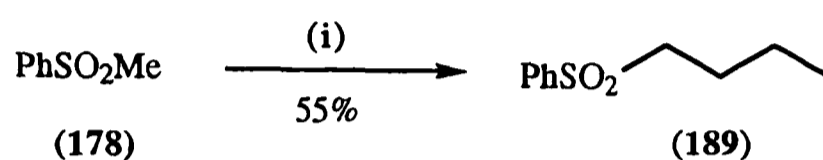

(i) *n*BuLi (1 eq.) then iodopropane (2 eq.), THF, -78°C to RT, 16h.

Scheme 55

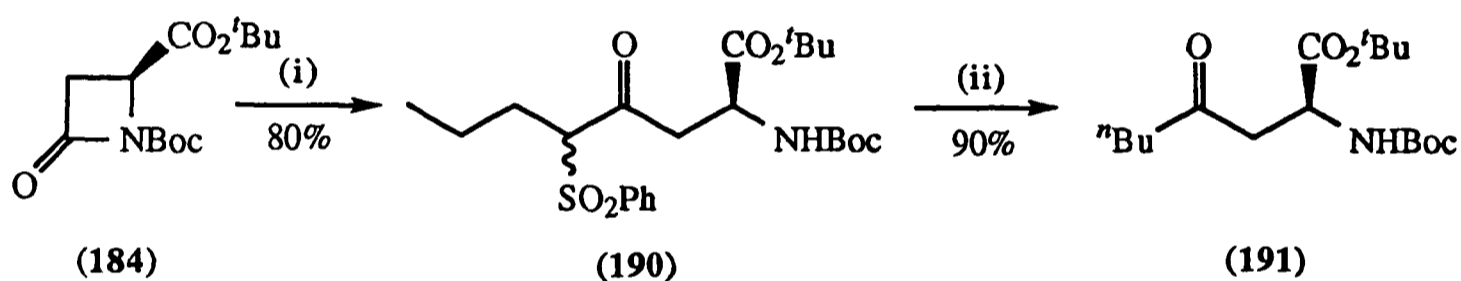

(i) PhSO₂*n*Bu (189) (2 eq.), *n*BuLi (2 eq.), THF, -78°C, 30min. then aq. NH₄Cl;
 (ii) Al/Hg, deoxygenated THF:H₂O 9:1.

Scheme 56

In order to synthesise the amino acid (34) *via* this sulfone addition strategy, it would be preferable, in terms of convergency, to introduce the desired oxygenation into the sulfone prior to β -lactam ring opening. Thus, the preparation of 1-phenylsulfonyl-3-hydroxybutane (192) would be required and furthermore as the absolute stereochemistry of the hydroxyl centre of WF-10129 (20) is uncertain it would at some stage be necessary to prepare both the (3*R*) and (3*S*) forms. A number of routes were available to racemic (192) but few offered a potential entry into the homochiral alcohols. However, as Babler has reported that racemic propylene oxide is regioselectively ring opened by lithiated methylphenylsulfone (178) to generate (192), this indicated that one possible method to the homochiral sulfones would be

to react lithiated (178) with homochiral propylene oxide. The racemic form of this sulfone was initially prepared by the reaction of (*RS*)-propylene oxide in 93% yield.¹¹⁵ After further developing the methodology this intermediate would be prepared in homochiral form. The hydroxy function of (192) was subsequently protected as its *t*-butyldimethylsilylether in high yield, Scheme 57.

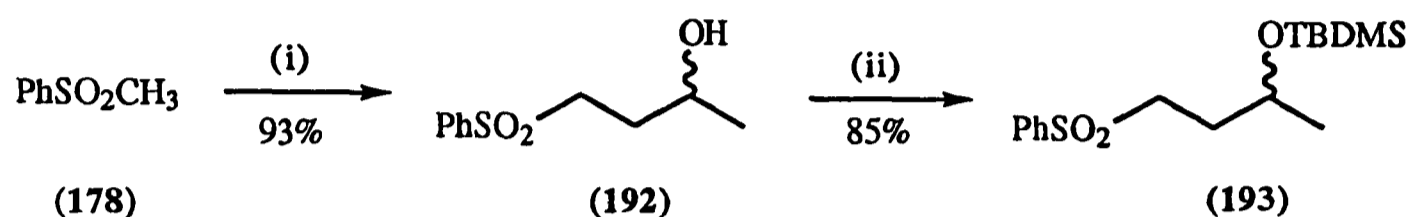

(i) ⁿBuLi (1 eq.) then propylene oxide (1.2 eq.), THF, -78°C to RT, 16h. then aq. NH₄Cl;
 (ii) TBDMSCl (1.2 eq.), imidazole (2.5 eq.), DMF, RT, 20h.

Scheme 57

This synthetic strategy proved to be successful as ring opening of (184) with lithiated sulfone (193) gave a yield of 82% of (194) which was then subjected to aluminium amalgam reduction in 85% yield, Scheme 58.

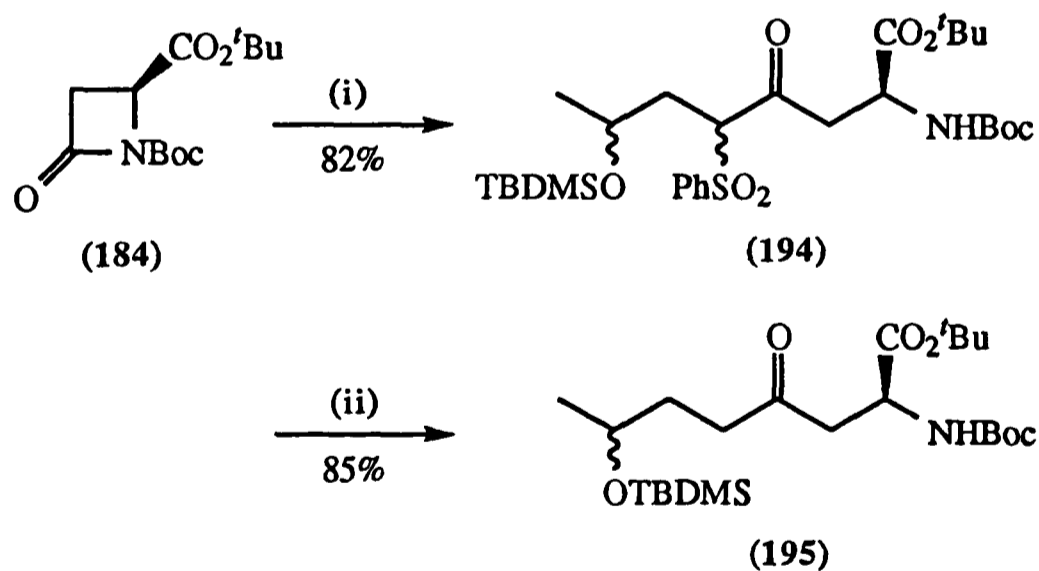

(i) (193) (2 eq.), ⁿBuLi (2 eq.), THF, -78°C, 10min. then aq. NH₄Cl;
 (ii) Al/Hg, deoxygenated THF:H₂O 9:1.

Scheme 58

In order to synthesise WF-10129 (20) it would be necessary to reveal the amine group before coupling to a protected form of triflate (35), see Scheme 3. Unfortunately, all

attempts to selectively remove the *t*-butoxycarbonyl group of (195) with *p*-toluenesulfonic acid monohydrate¹¹⁶ and hence obtain, after base extraction, free amine (196) resulted in decomposition. It was apparent that along with the *t*-butoxycarbonyl the *t*-butyldimethylsilyl group was also being removed under these mildly acidic conditions. In an attempt to resolve the problem the analogous protected amino acid (196) in which the *t*-butyldiphenylsilyl ether replaced the *t*-butyldimethylsilyl ether as the hydroxyl protecting group was prepared, Scheme 60.¹¹⁷ The TBDPS ether was reported to be substantially less labile under acidic conditions and although this was found to be the case the desired amine (200) was not obtained, decomposition being observed, Scheme 60.

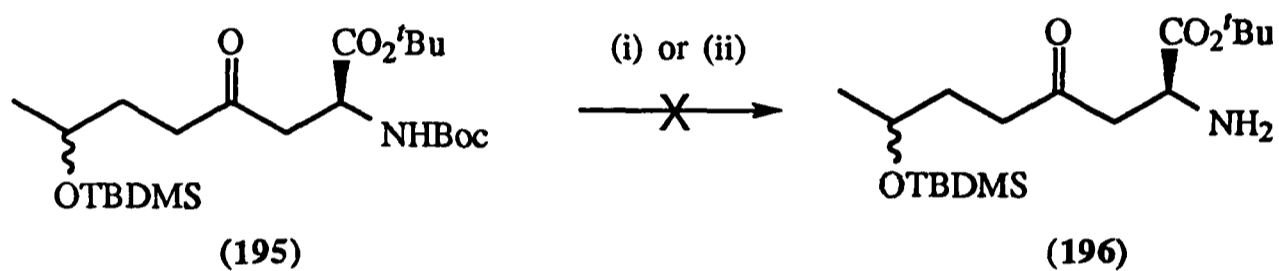

(i) *p*-TsOH.H₂O (1 eq.), Et₂O/EtOH (concentrated *in vacuo*);
(ii) *p*-TsOH.H₂O (1 eq.), MeOH, RT, 18h.

Scheme 59

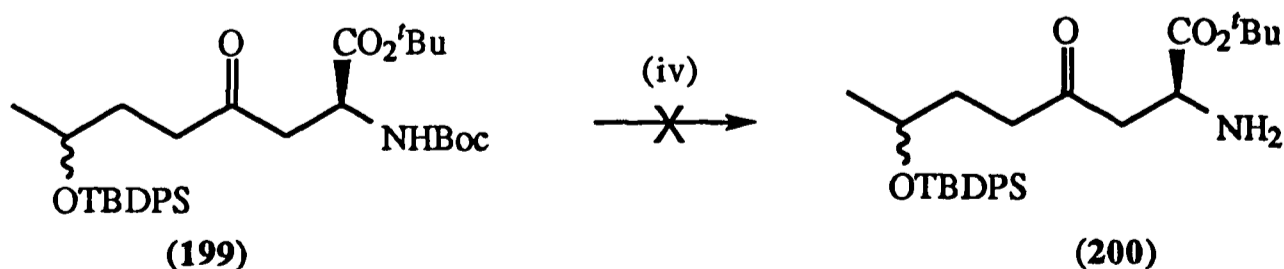
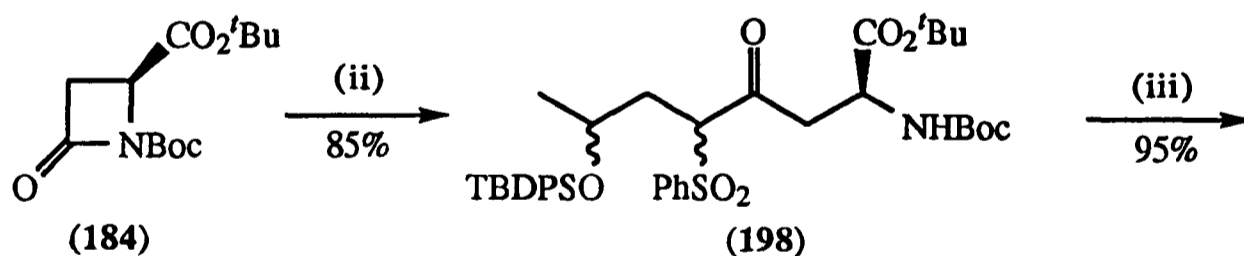
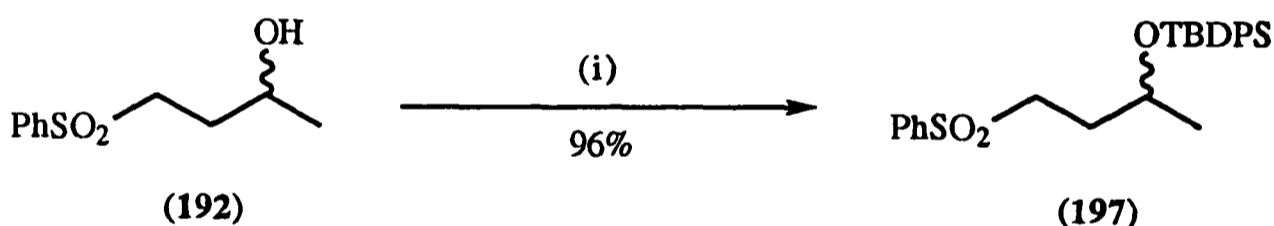

(i) TBDPSCl (1.2 eq.), imidazole (2.5 eq.), DMF, RT, 20h.; (ii) (197) (2 eq.), *n*-BuLi (2 eq.), THF, -78°C, 10 min. then aq. NH₄Cl; (iii) Al/Hg, deoxygenated THF:H₂O 9:1; (iv) *p*-TsOH.H₂O (1 eq.), MeOH.

Scheme 60

To clarify the situation the model system (186) was examined. It was also found to be impossible to obtain the free amine (201) from the methylketone (186) by treatment with *p*-toluenesulfonic acid monohydrate. It was proposed based on spectroscopy that intermolecular imine formation was taking place leading to oligomer formation. It was, however, possible to obtain (202) from benzyl ester (159) by treatment of (159) with trifluoroacetic acid but as the overall yield of (159) from β -lactam (145) was low (for reasons discussed above) the use of (145) in the synthesis of (34) was undesirable, Scheme 61.

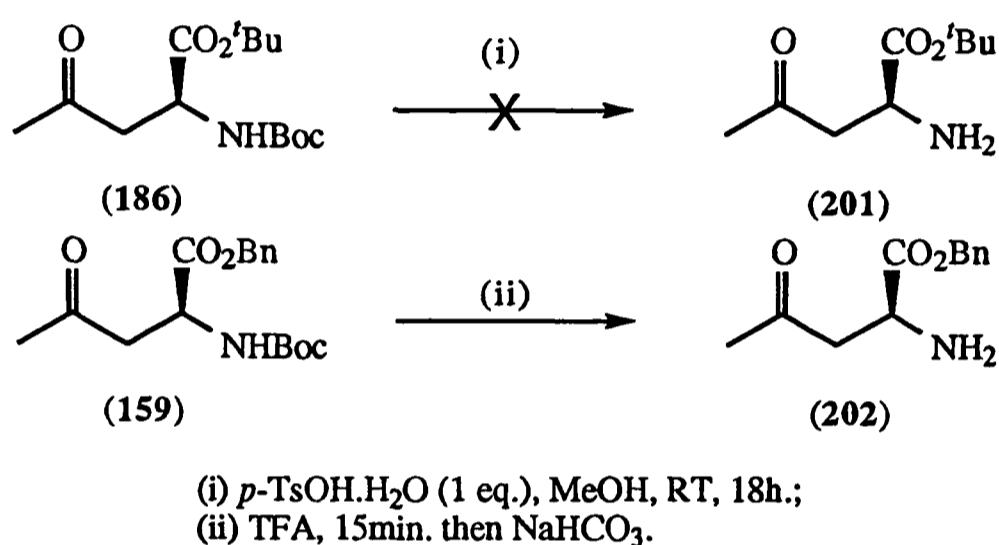

Scheme 61

At this point it was decided that a nitrogen protecting group that was more easily differentiated from the *t*butyl ester was required and accordingly the benzyl carbamate was selected. Therefore the synthesis of the novel β -lactam *t*butyl *N*-(benzyloxycarbonyl)azetidin-2-one-4-carboxylate (203) was carried out as indicated in Scheme 62. Dibenzyl dicarbonate,¹¹⁸ which had recently become commercially available, proved to be an excellent reagent for the formation of the benzyl carbamate in the presence of catalytic DMAP affording (203) in a 95% yield.

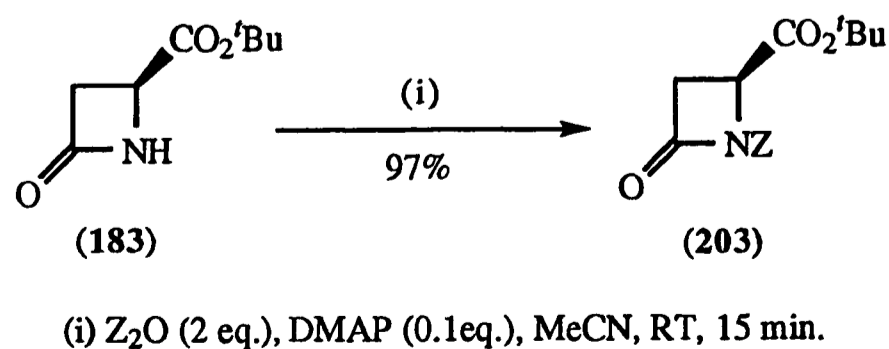

Scheme 62

It now remained to ensure that this slight modification did not affect the chemistry already developed. Ring opening of (203) with both the lithiated methylphenylsulfone (178) and (3*RS*)-1-phenylsulfonyl 3-*t*-butyldimethylsilyloxybutane (193) and subsequent removal of the sulfone moiety in each case also proceeded in high yields, Scheme 63. This was in keeping with previous observations in this study.

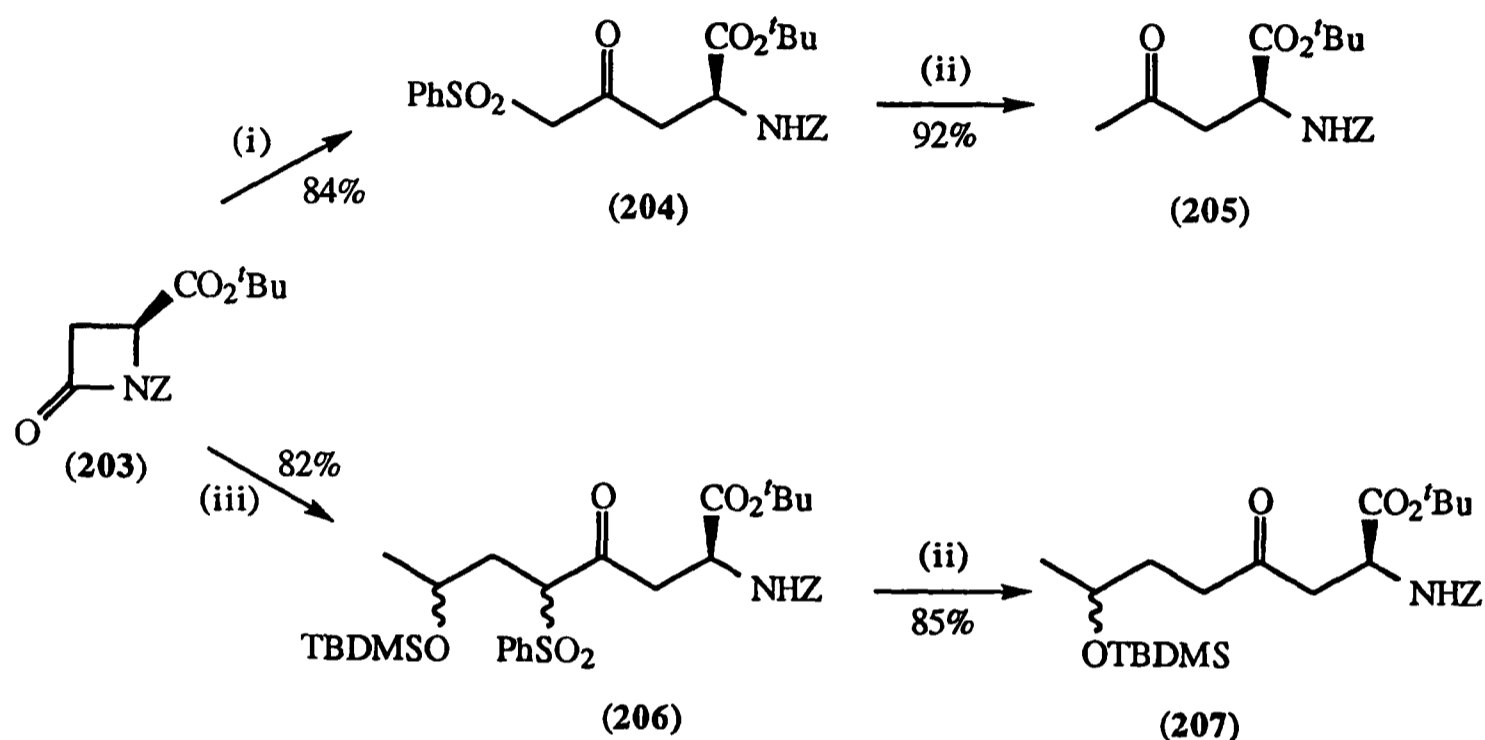

- (i) (178) (2 eq.), ⁿBuLi (2 eq.), THF, -78°C, 10min. then aq. NH₄Cl;
(ii) Al/Hg, deoxygenated THF:H₂O 9:1;
(iii) (193) (2 eq.), ⁿBuLi (2 eq.), THF, -78°C, 10min. then aq. NH₄Cl.

Scheme 63

Hydrogenolysis of the N-benzyloxy protecting group of (205) with hydrogen and 10% Pd/C as catalyst was rapid but the resulting amine was impure. It was thought that intermolecular imine formation was again taking place under the very slightly acidic conditions of the reaction.[†] This significant problem was solved by hydrogenolysis using 5% Pd/CaCO₃, a weakly basic catalyst. Although this reaction was not as rapid the free amine (208) was generated in a high state of purity and in quantitative yield. Similarly (207) was subject to hydrogenolysis with 5% Pd/CaCO₃ as catalyst to afford amine (196).

[†] Experience in the group has indicated that acid labile protecting groups are occasionally unstable under these conditions.¹¹⁹

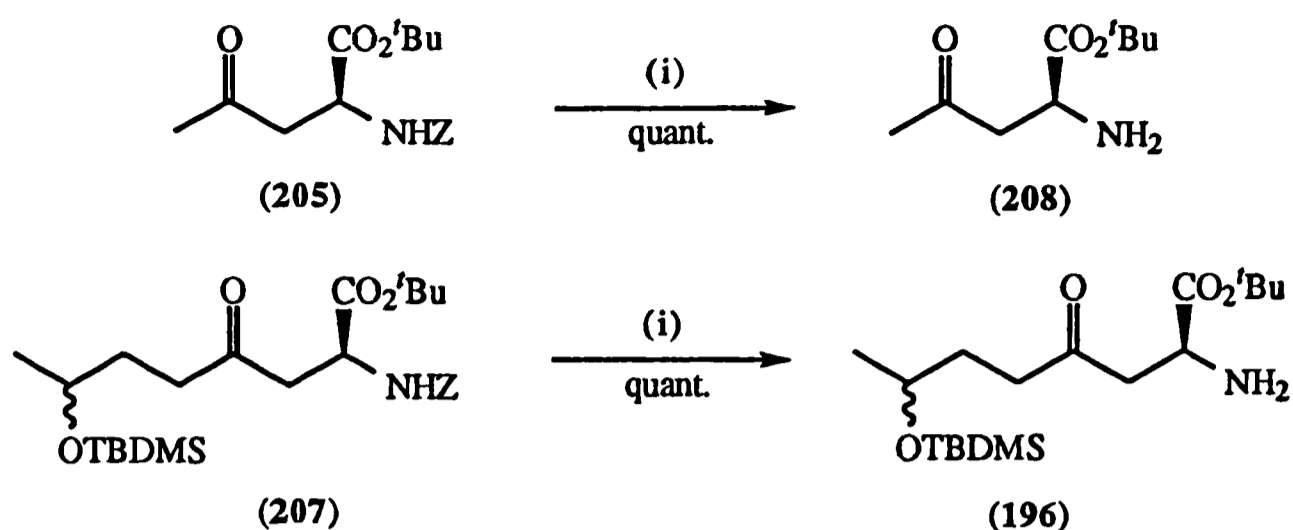
(i) H₂, 5% Pd/CaCO₃, EtOAc, 30min.

Scheme 64

One unresolved issue was the optical purity of the γ -keto- α -amino acids formed by this route, since it was possible that a basic species such as lithiated sulfone (178) could cause racemisation of the α -amino ester centre *via* a deprotonation, reprotonation sequence. The enantiomeric purity of the amine (208) was determined by its conversion to both the (*S*) and (*R*) Mosher's amide derivatives (211) and (212), Scheme 66, with (*R*) and (*S*) Mosher's acid chloride prepared as in Scheme 65 from the corresponding carboxylic acids using a scaled-up version of the method reported by Ward and Rhee¹²⁰ respectively. Both the ¹H and ¹⁹F n.m.r. spectroscopy of the amide derivatives (211) and (212) indicated no detectable contamination with the other diastereomer. Thus, it can be concluded that amino ester (208) is optically pure and that no detectable racemisation has taken place during its preparation. Based on this observation it was assumed, at this stage, that all other γ -keto- α -amino acids prepared by the sulfone addition route were enantiomerically pure at the α -amino ester centre, a fact later confirmed for compounds pertinent to WF-10129.

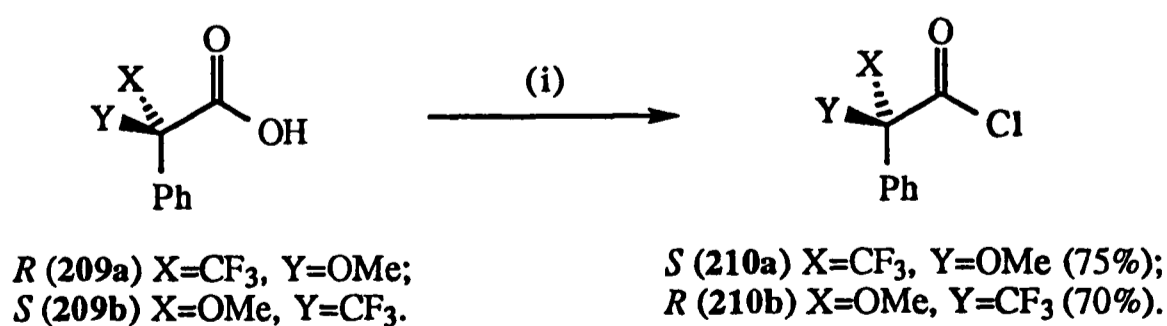

(i) oxalyl chloride (3 eq.), DMF (cat.), hexane.

Scheme 65

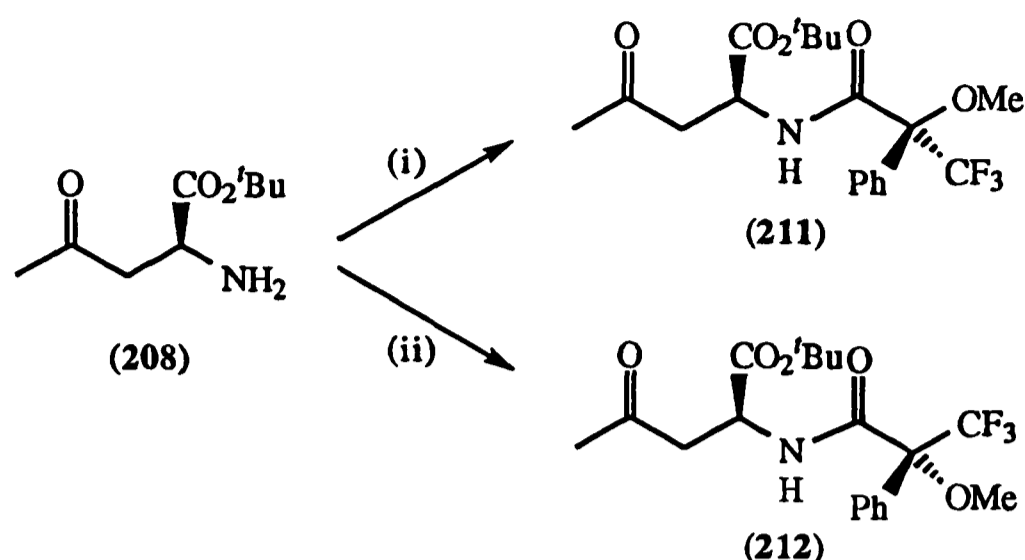

(i) (*R*)-Mosher's acid chloride (1.2 eq.), DMAP (1.2 eq.), DCM, RT, 24h.;
(ii) (*S*)-Mosher's acid chloride (1.2 eq.), DMAP (1.2 eq.), DCM, RT, 24h.

Scheme 66

10.2.3 β -Lactam Ring Opening with Lithiated Phosphonates; Synthesis of the Enantiomer of a Potent NMDA Antagonist

The sulfone anion addition to β -lactams strategy offered a promising entry into the required (6'*S*) or (6'*R*)- γ -keto- α -amino acids (**34**) (Scheme 3) for the synthesis of WF-10129 (**20**). Before this was addressed it was decided to investigate further the range of stabilised and unstabilised carbon based nucleophiles that could be used to generate γ -keto- α -amino acids by ring opening activated monocyclic β -lactams such as (**184**) and (**203**).

The ring opening of β -lactams with lithiated phosphonates was examined. Lithiated methyl diethylphosphonate smoothly ring opened (**184**) and (**203**) to afford (**213**) and (**214**) respectively, Scheme 67. In keeping with observations made during the development of the sulfone methodology two equivalents of phosphonate were required in order to secure high yields of the ring opened products. An analogous regioselective ring opening of *N*-Boc-pyroglutamate ethyl ester (**215**) was recently reported by Ezquerro, Scheme 68.¹²¹

Hydrogenolysis of (**214**) to afford free amine (**217**) was again followed by formation of Mosher's derivatives whose ¹H and ¹⁹F n.m.r. spectra revealed that no detectable racemisation had occurred during their preparation, Scheme 69.¹²²

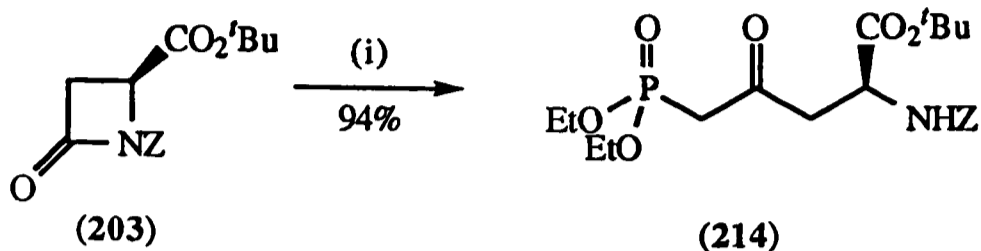
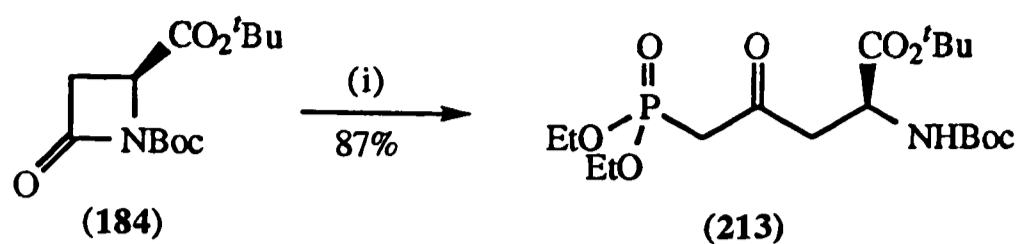

(i) $\text{CH}_3\text{P}(\text{O})(\text{OEt})_2$ (2 eq.), $n\text{BuLi}$ (2 eq.), THF, -78°C , 30min.
then aq. NH_4Cl .

Scheme 67

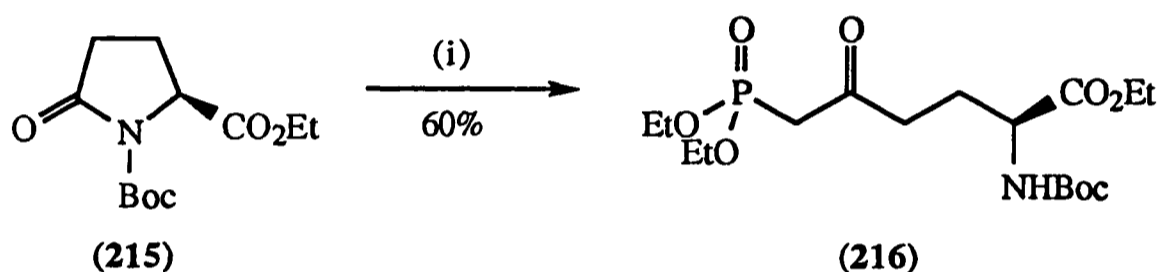

(i) $\text{CH}_3\text{P}(\text{O})(\text{OEt})_2$ (1.03eq.), LDA (1.03eq.), THF, -78°C to RT, 3.5-4.5h.

Scheme 68

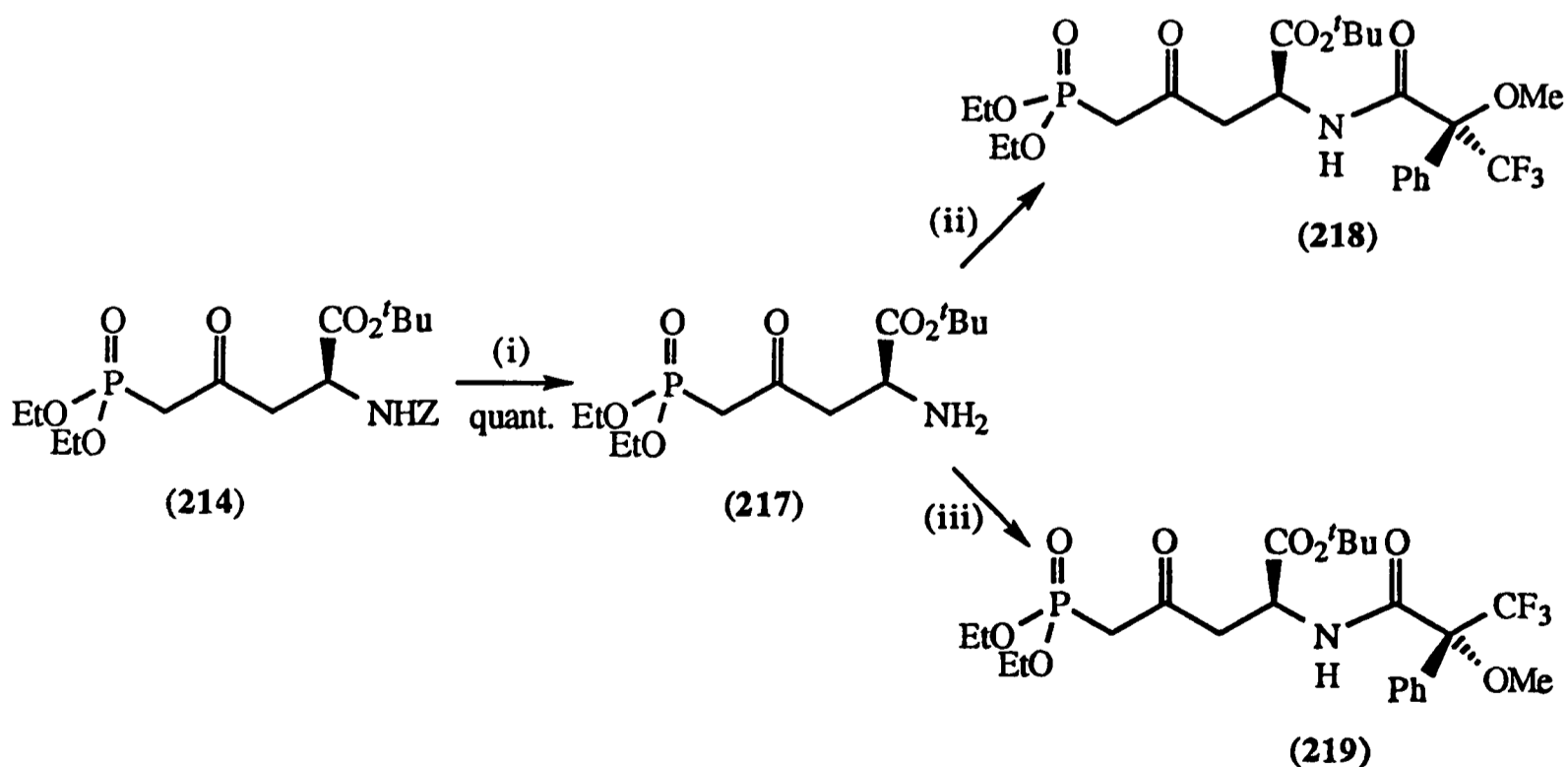

(i) H_2 , 5% Pd/ CaCO_3 , EtOAc, RT, 1h.;
(ii) (*R*)-Mosher's acid chloride (1.2 eq.), DMAP (1.2 eq.), DCM, RT, 24h;
(iii) (*S*)-Mosher's acid chloride (1.2 eq.), DMAP (1.2 eq.), DCM, RT, 24h.

Scheme 69

Additionally, (213) was globally deprotected using TMSI followed by methanolysis of the intermediate silylestere and amines to afford (220), the enantiomer of the potent NMDA antagonist (83) previously synthesised by the Merck group (Section 8.3.3).^{52,53} As the reaction was carried out on too small a scale for the propylene oxide induced precipitation reported by Merck to be an effective method for the purification of (220), ion exchange chromatography was utilised in order to obtain (2*S*)-4-oxo-5-phosphonorvaline (220) as a white crystalline solid in a 70% overall yield from (184).[‡]

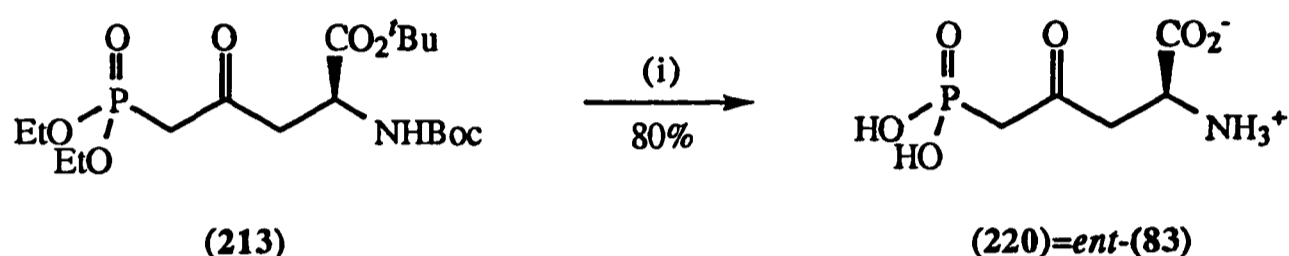

(i) TMSI (3 eq.), DCM, MeCN, RT, 24h. then MeOH, RT, 1h.

Scheme 70

Although the application of this methodology to the enantiomer of β-lactam (184) would offer a substantial improvement in terms of yield over the Merck groups original synthesis of (83),⁵² subsequent to this study an improved four step procedure to (83) from (*D*)-aspartic acid (84) was published (Section 8.3.3).⁵³

10.2.4 β-Lactam Ring Opening with Cuprates

To further probe the reactivity of β-lactams such as (144) and (184) with other organometallic reagents ring opening with cuprates were examined. Initially, ring opening with the Lipshutz higher order cyano cuprate (224)¹²³ was attempted and found to give moderate yields of the requisite ketones, Scheme 71. However, in each case the corresponding butyl esters (221) and (223) were also obtained. Their formation was unexpected but it was postulated that they may have arisen from the reaction of *n*-butyllithium with oxygen which generated lithium *n*-butoxide that then cleaved the amide bond. The use of fresh *n*-butyllithium and thorough deoxygenation of the reaction solvent led to reduced

[‡] (220) possessed an optical rotation of -5.4 (*c* 0.25, H₂O). An authentic sample of (2*R*)-4-oxo-5-phosphonorvaline (83) possessed an optical rotation of +6.0 (*c* 0.25, H₂O).

quantities of (221) and (223) but somewhat surprisingly the isolated yields of (191) and (222) could not be improved. It is also of interest to note that in the case of (144) no product derived from the attack of the cuprate on the benzyl ester was observed.

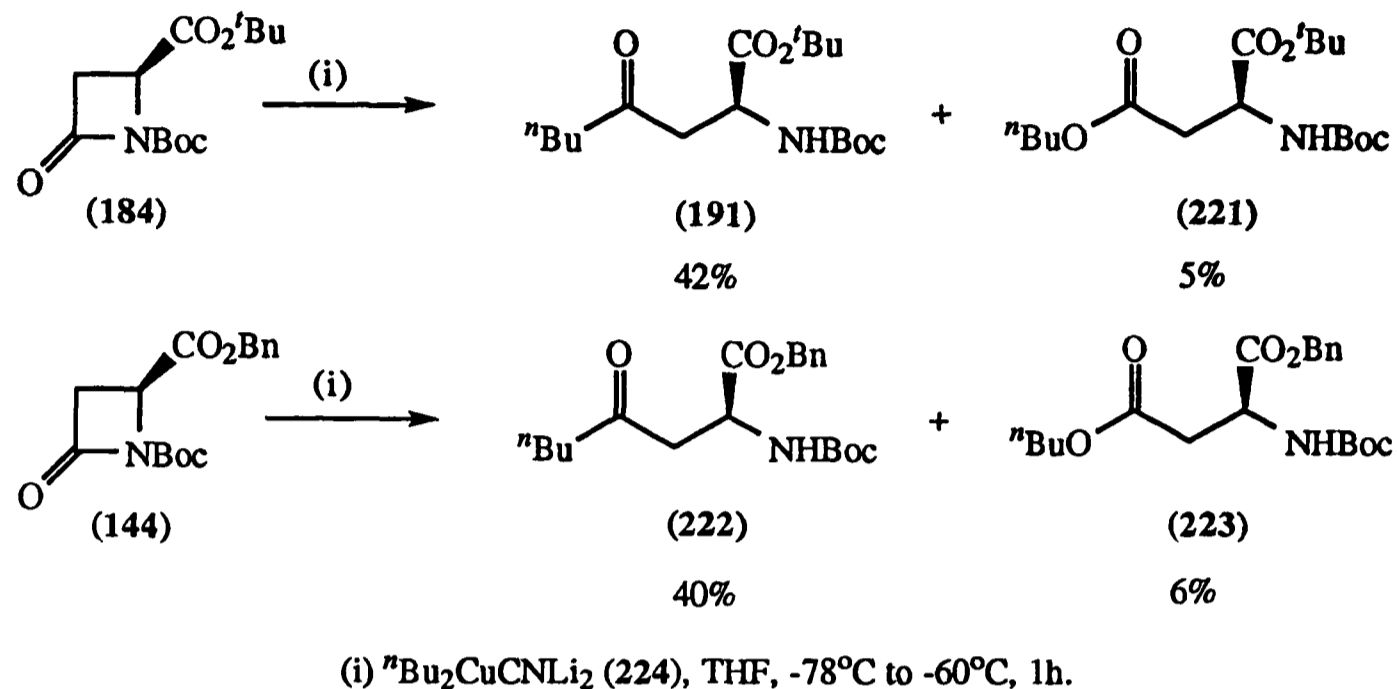

Scheme 71

Deprotection of (222) afforded the free amine (225). Analysis of the Mosher's esters¹²² (226) and (227) formed from (225) in the same manner as above indicated that no detectable racemisation had occurred, Scheme 72. Furthermore, the specific rotation of (222) prepared by this route [$+19.4$ (c 1, CHCl_3)] was found to be in agreement with that of the same compound prepared *via* the sulfone addition route, [$+20.8$ (c 1, CHCl_3)] above.

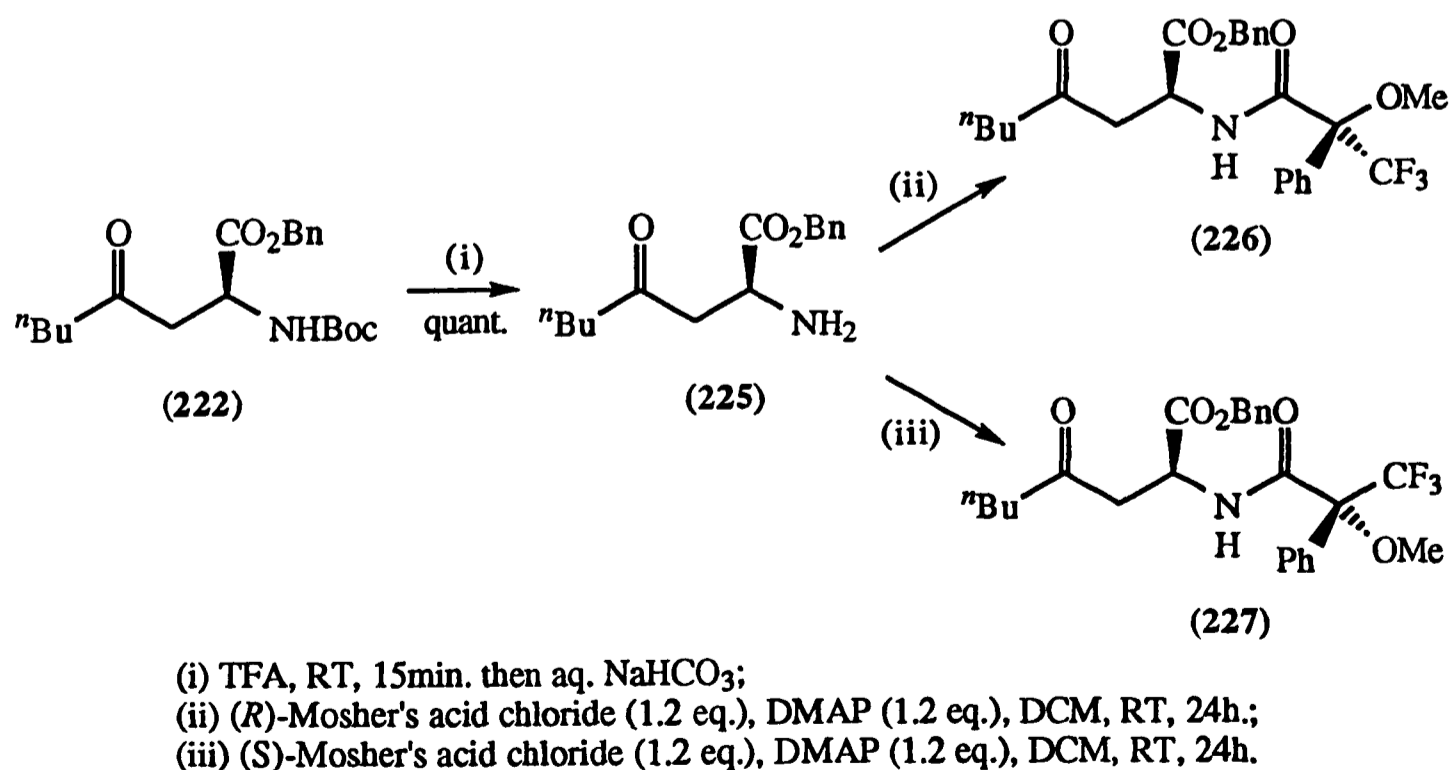

Scheme 72

Unfortunately, the ring opening of activated monocyclic β -lactams such as (144) with cuprates was not a general procedure with both the methyl Lipshutz higher order cuprate (229)¹²³ and the cuprate (230) derived from the reaction of 2-thienyl(cyano)copper lithium (231)¹²⁴ with methyl lithium, Scheme 73 resulting in decomposition. However, the successful reactions of (224) suggests that the carbonyl group of monocyclic β -lactams such as (144) and (184), that have been activated toward nucleophilic attack, by the presence of the carbamate group on nitrogen, exhibit a reactivity toward nucleophilic attack that is similar to the carbonyl group of aldehydes.¹²⁵ The reactivity of species such as (144) toward nucleophiles is, therefore, greater than has previously been believed.

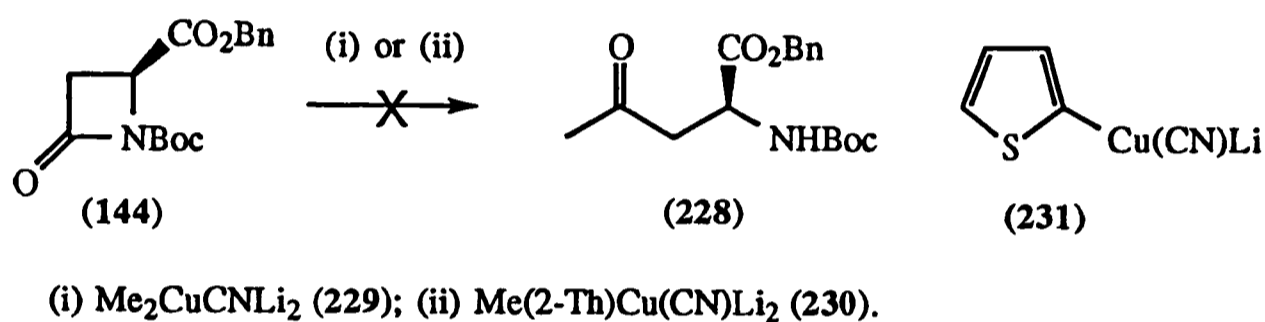

Scheme 73

10.3 Confirmation of the Stereochemistry and Structure of WF-10129 Through Total Synthesis

10.3.1 Introduction

The next stage in the synthesis of WF-10129 (20) would involve the $\text{S}_{\text{N}}2$ displacement by amine (34) of a protected form of the triflate (35) derived from (*D*)-lactic acid. In the first instance (*S*)-benzyl 2-trifluoromethanesulfonyloxypropanoate (234) was prepared in two steps from the lithium salt of the less expensive (*L*)-lactic acid (232), Scheme 74.^{19,126} Purification of triflate (234) was achieved by rapidly passing the reaction residue through a silica gel plug with P.E. 30-40 as eluent. The amine (196) was successfully coupled with (235) in the presence of triethylamine¹⁹ on a small scale and in good yield to afford (235), Scheme 74.

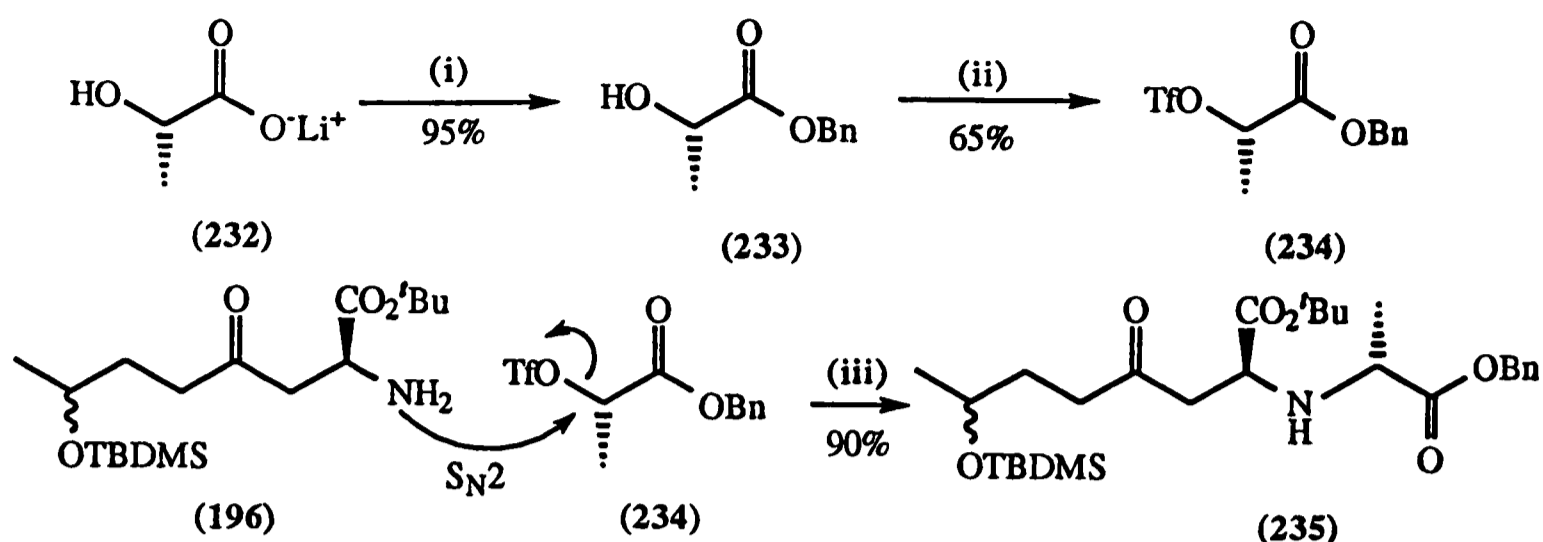

(i) BnBr (5 eq.), DMF, 50°C, 20h.; (ii) Tf₂O (1 eq.), pyridine (1 eq.), DCM, 0°C, 20min.;
 (iii) Et₃N (1 eq.), DCM, RT, 2h.

Scheme 74

Hydrogenolysis of (235) was followed by the attempted coupling of carboxylic acid (236) to (*L*)-tyrosine ^tbutyl ester. A variety of coupling reagents were investigated with a DCC/HOBt mediated protocol proving to be the most efficient affording dipeptide (237) in a reasonable 70% yield with protection of the tyrosine hydroxyl group proving unnecessary. Attempts to remove the silicon protecting group of (237) with TBAF gave a complex mixture of products. It was subsequently discovered that global deprotection of (237) could be achieved with trifluoroacetic acid (TFA) in the presence of anisole, as a scavenger for the ^tbutyl cation, to afford (238) as its trifluoroacetate salt in a 77% yield following concentration of the solution and lyophilisation, Scheme 75.

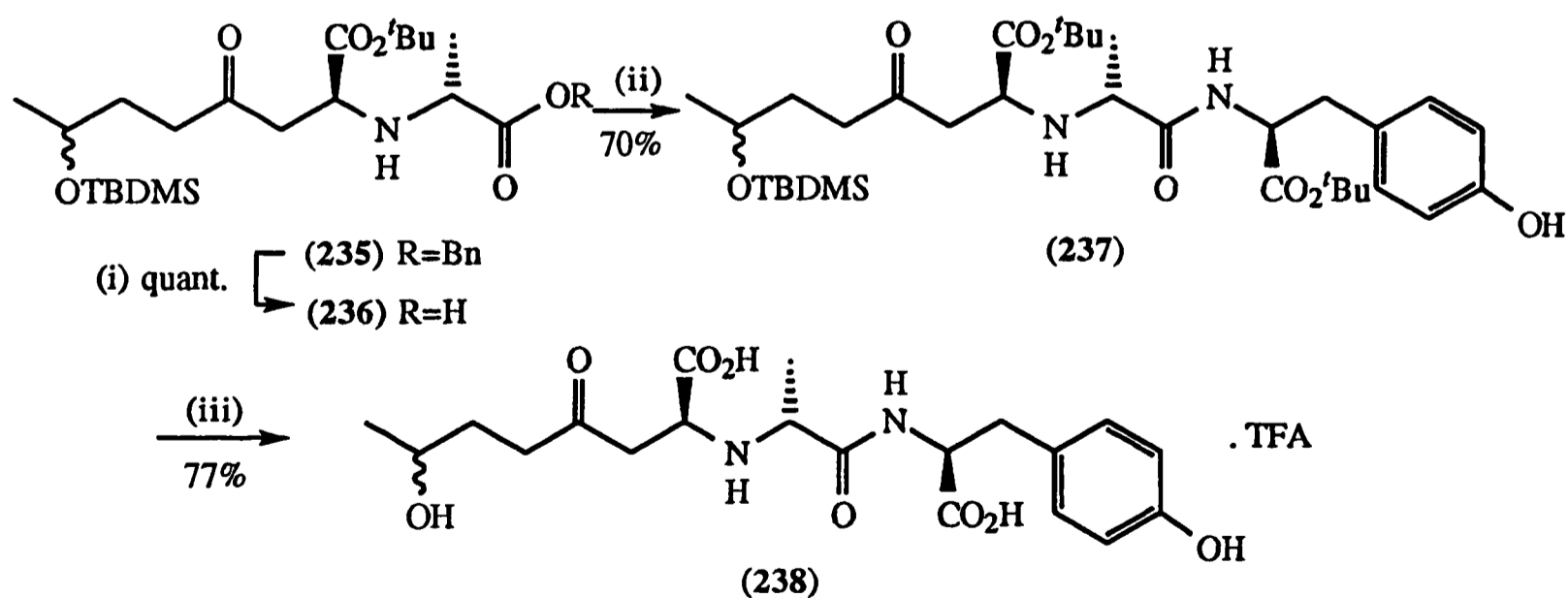

(i) H₂, 10% Pd/C, EtOAc; (ii) (*L*)-tyrosine ^tbutyl ester (239) (1 eq.), DCC (1.1 eq.), HOBt (1.1 eq.), DCM, 1h.; (iii) TFA, anisole, RT, 1h.

Scheme 75

10.3.2 Synthesis of Diastereoisomer (20a)

Thus with the methodology for the conversion of (34) to WF-10129 (20) in hand, the synthesis of the four possible diastereoisomers of (20) was undertaken. This would allow for the comparison of the properties of all the possible stereoisomers with those of the natural product and hence allow deduction of the structure of WF-10129 (20). The first target was isomer (20a) which has the *S* stereochemistry at all chiral centres. Thus the lithiated form of methylphenylsulfone (178) was reacted with (*S*)-propylene oxide¹¹⁵ to afford (241) after protection of the hydroxy group of (240) as its silyl ether, Scheme 76.¹²⁷

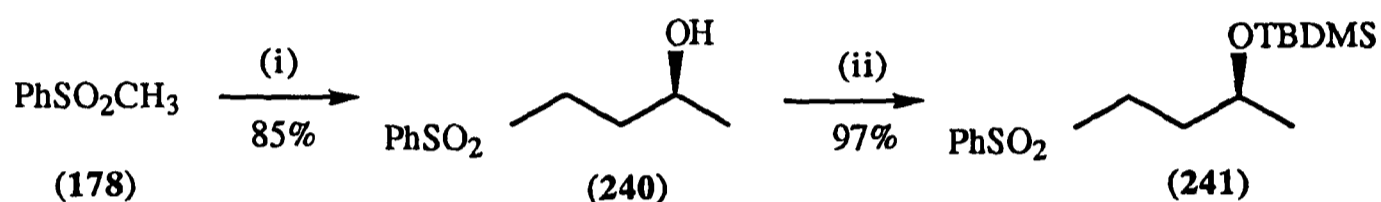

(i) ⁿBuLi (1 eq.), then (*S*)-propylene oxide (1.2 eq.), THF, -78°C to RT, 16h.;

(ii) TBDMSCl (1.2 eq.), imidazole (2.5 eq.), DMF, RT, 20h.

Scheme 76

Ring opening of (203) with the lithiated form of sulfone (241) again proceeded in high yield and was followed by reductive removal of the sulfone group¹¹² and hydrogenolysis to afford amine (244), Scheme 77.

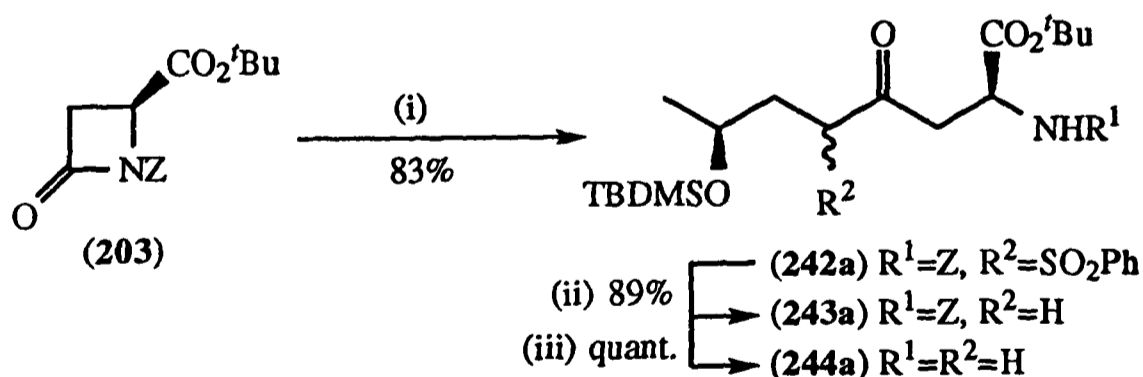

(i) (241) (2 eq.), ⁿBuLi (2 eq.), THF, -78°C, 10 min. then aq. NH₄Cl;

(ii) Al/Hg, deoxygenated THF:H₂O 9:1; (iii) H₂, 5%Pd/CaCO₃, EtOAc.

Scheme 77

Amine (244a) was subject to S_N2 reaction with (*S*)-benzyl 2-trifluoromethanesulfonyloxypropanoate (247) (derived from (*D*)-lactic acid), Scheme 78.

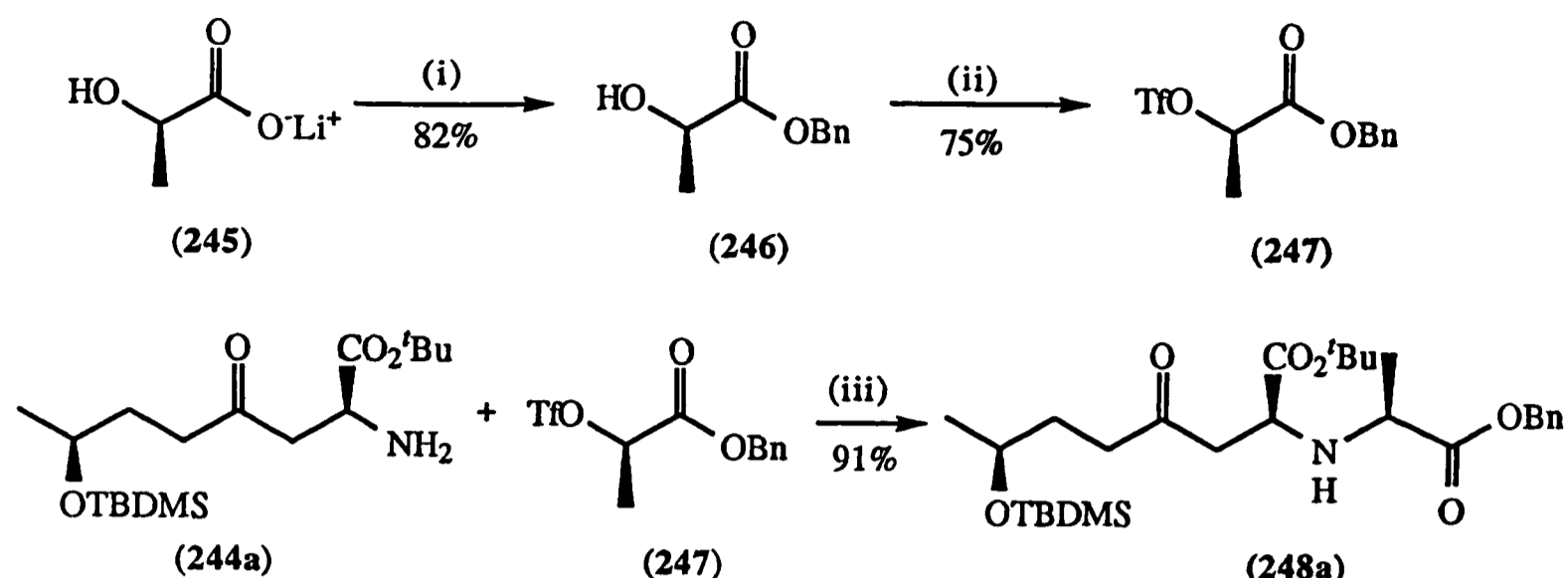

(i) BnBr (5 eq.), DMF, 50°C, 20h.; (ii) Tf₂O (1 eq.), pyridine (1 eq.), DCM, 0°C, 20min.;
 (iii) Et₃N (1 eq.), DCM, RT, 2h.

Scheme 78

Hydrogenolysis and coupling to (*L*)-tyrosine *t*-butyl ester afforded dipeptide (250a) which underwent complete deprotection on treatment with TFA/anisole to generate the *S,S,S,S* diastereoisomer (20a) as its trifluoroacetate salt, Scheme 79.

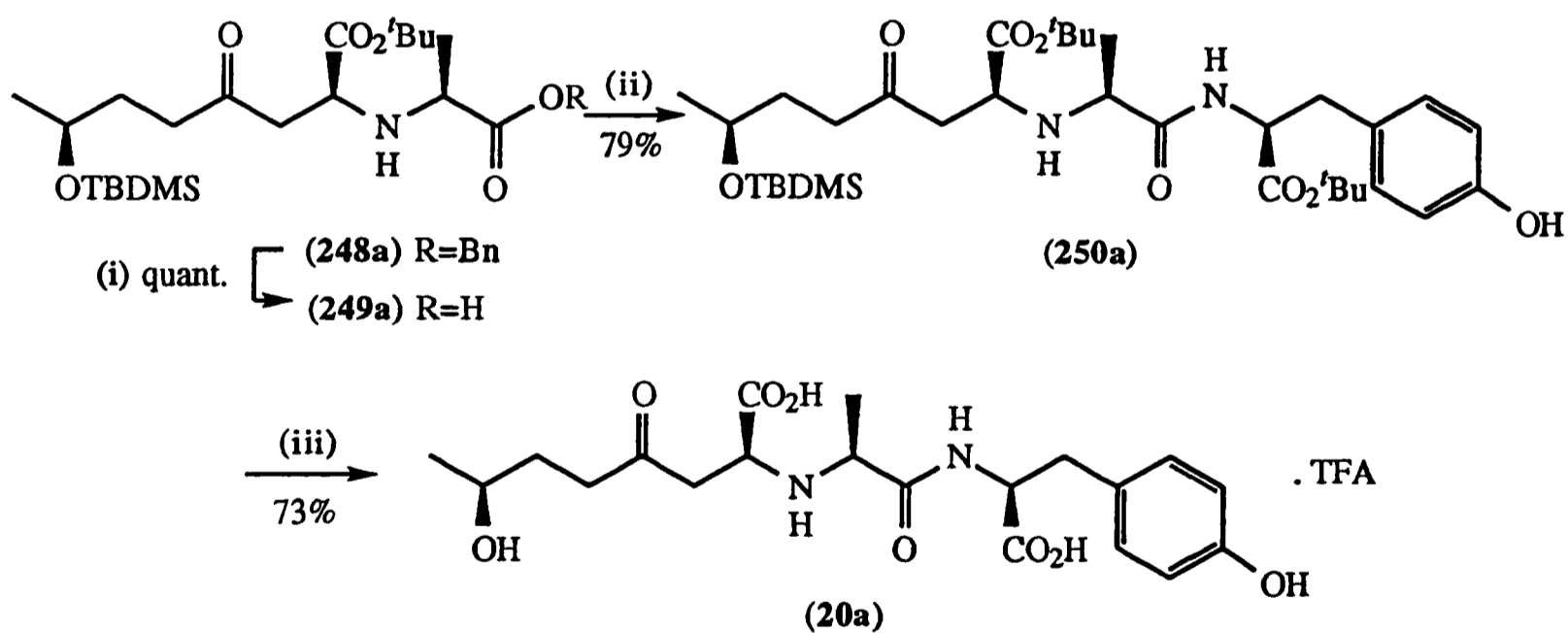

(i) H₂, 10% Pd/C, EtOAc; (ii) (*L*)-tyrosine *t*-butylester (1 eq.), DCC (1.1 eq.), HOBT (1.1 eq.), DCM, 1h.; (iii) TFA, anisole, RT, 1h.

Scheme 79

WF-10129 (20), isolated by Ando, had been purified by successive ion exchange chromatography of the culture broth and finally by reverse phase h.p.l.c with 8% MeCN in

0.05% TFA as the eluent. Thus, as it was thought likely that WF-12129 (**20**) had been isolated as its trifluoroacetate salt, for the sake of comparison no attempt was made to convert the synthetic sample (**20a**) to the free amino acid.

The synthetic isomer (**20a**) was found to decompose slowly at room temperature and further purification, if necessary, could be achieved by reverse phase h.p.l.c. according to the conditions reported by Ando.¹⁵ This decomposition reaction generated the dipeptide (*LL*)-alanyltyrosine (**252**). As WF-10129 (**20**) is degraded to the respective amino acids with 6M HCl it is proposed that the bond *a* is prone to cleavage under acidic conditions presumably *via* the mechanism indicated in Scheme 80.

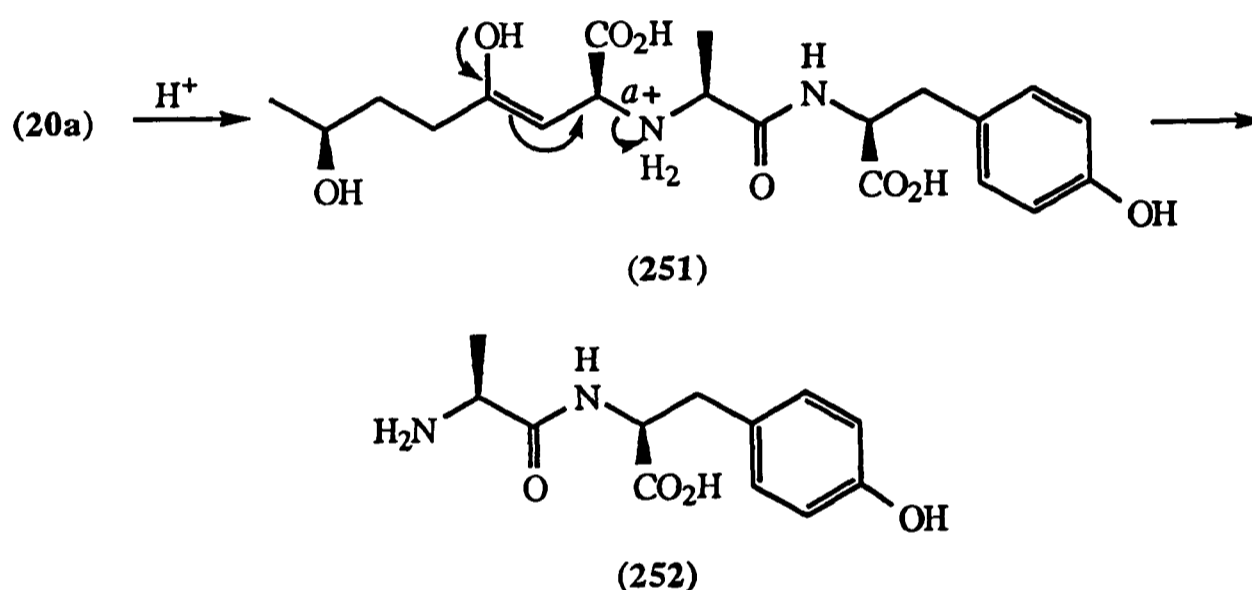

Scheme 80

10.3.3. Synthesis of Diastereoisomers (**20b**), *ent*-(**20c**) and *ent*-(**20d**)

Isomer (**20b**) was prepared in an analogous manner to (**20a**). Hence, (*3R*)-1-phenylsulfonyl 3-*t*-butyldimethylsilyloxybutane (**254**) was prepared from (*2R*)-propylene oxide and the lithiated form of methylphenylsulfone (**178**) followed by silyl protection of the hydroxy group, Scheme 81.

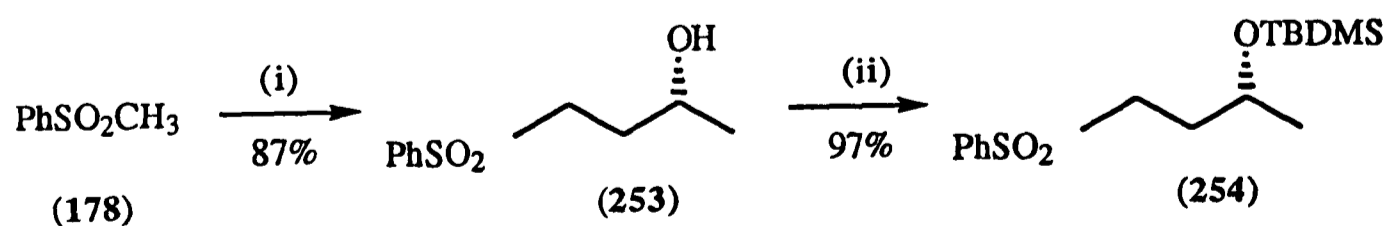

- (i) $t\text{BuLi}$ (1 eq.), then (*S*)-propylene oxide (1.2 eq.), THF, -78°C to RT, 16h.;
(ii) TBDMCl (1.2 eq.), imidazole (2.5 eq.), DMF, RT, 20h.

Scheme 81

Ring opening of (203) with (254) followed by desulfonation, hydrogenolysis, S_N2 reaction with (247) and hydrogenolysis afforded (249b) which was subsequently coupled to (*L*)-tyrosine to afford (250b). Global deprotection afforded (20b), Scheme 82.

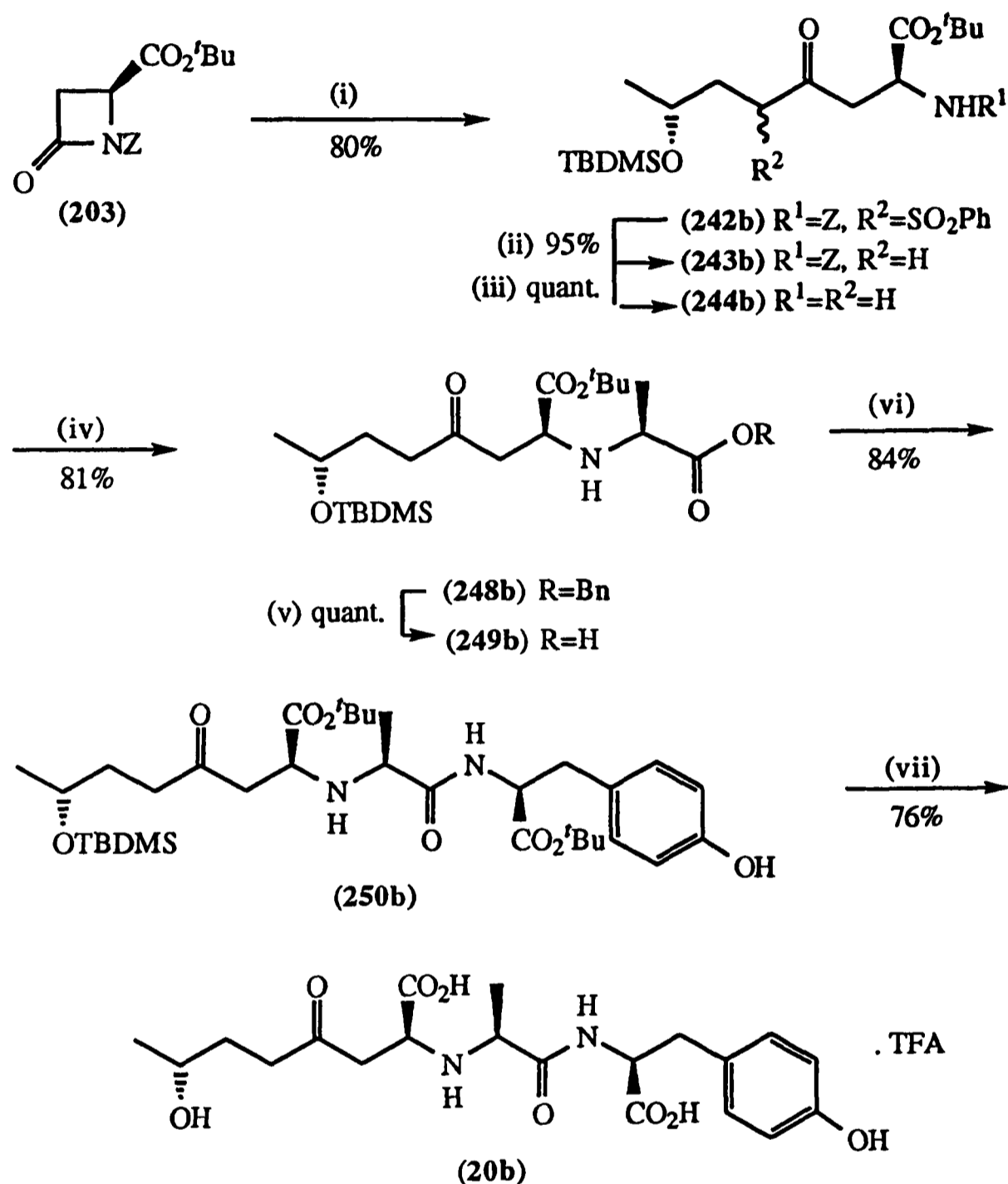

- (i) (254) (2 eq.), ^tBuLi (2 eq.), THF, -78°C, 10 min. then aq. NH₄Cl;
(ii) Al/Hg, deoxygenated THF:H₂O 9:1; (iii) H₂, 5%Pd/CaCO₃, EtOAc;
(iv) (247), Et₃N (1 eq.), DCM, RT, 2h; (v) H₂, 10% Pd/C, EtOAc;
(vi) (*L*)-tyrosine ^tbutyl ester (239) (1 eq.), DCC (1.1 eq.), HOBT (1.1 eq.), DCM, 1h.;
(vii) TFA, anisole, RT, 1h.

Scheme 82

It was intended to make the assignment of the stereochemistry of WF-10129 (20) primarily on the basis of n.m.r spectroscopy and as (244a) and (244b) were available it was decided to prepare the enantiomers of (20c) and (20d) by coupling the fragments (244b)

and (244a) respectively with protected forms of (*L*)-lactic acid and (*D*)-tyrosine, as indicated in Scheme 83.

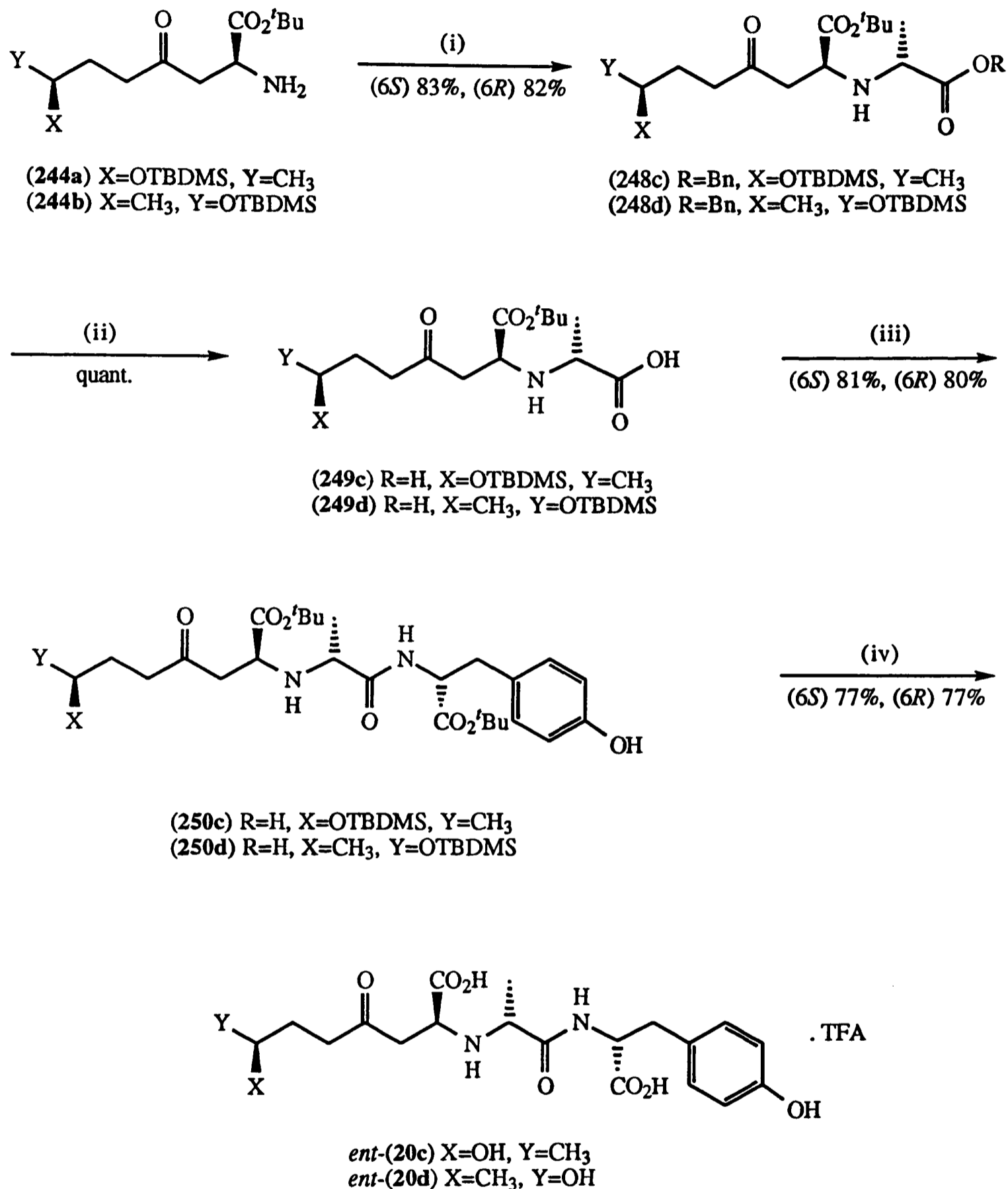

(i) (234), Et₃N (1 eq.), DCM, RT, 2h; (ii) H₂, 10% Pd/C, EtOAc; (iii) (*D*)-tyrosine ^tbutylester (1 eq.), DCC (1.1 eq.), HOBT (1.1 eq.), DCM, 1h.; (iv) TFA, anisole, RT, 1h.

Scheme 83

10.4 Assignment of the Stereochemistry of WF-10129

Comparison of the ^1H n.m.r and specific rotations of (20a), (20b), *ent*-(20c) and *ent*-(20d), Table 1, with that reported for WF-10129 (20) indicated that the stereochemistry was that of (20a) *i.e.* *S* at all stereocentres. Derivatisation of (20a) was carried out in an analogous manner to that reported by Ando *et al.*¹⁵ on the natural material, Scheme 84. Firstly treatment of (20a) with excess diazomethane afforded predominantly dimethyl ester (255) with smaller quantities of material in which the tyrosine hydroxyl had also been methylated. Acetylation of this mixture with acetic anhydride and pyridine then afforded diacetate (256) which was purified by silica gel chromatography. The ^1H n.m.r. of (20a) was also found to be in agreement with that reported, providing further evidence for (20a) being the correct structure of WF-10129 (20).

	<u>Optical rotation</u>	
WF-10129 (20)	+12.9	(<i>c</i> 0.375, H ₂ O)
(20a)	+14.2	(<i>c</i> 0.375, H ₂ O)
(20b)	+3.9	(<i>c</i> 0.375, H ₂ O)
<i>ent</i> -(20c)	+6.2	(<i>c</i> 0.37, H ₂ O)
<i>ent</i> -(20d)	+2.5	(<i>c</i> 0.37, H ₂ O)

Table 1

Inhibition studies of (20a) and (20b)¹²⁸ with ACE showed that both had similar potencies indicating that the stereochemistry of the hydroxyl centre is not critical for activity, Table 2.

<u>Inhibitor</u>	<u>IC₅₀ (M)</u>
Captopril (8)	3.6x10 ⁻⁸
(20a)	5.5x10 ⁻⁸
(20b)	7.4x10 ⁻⁸

Table 2

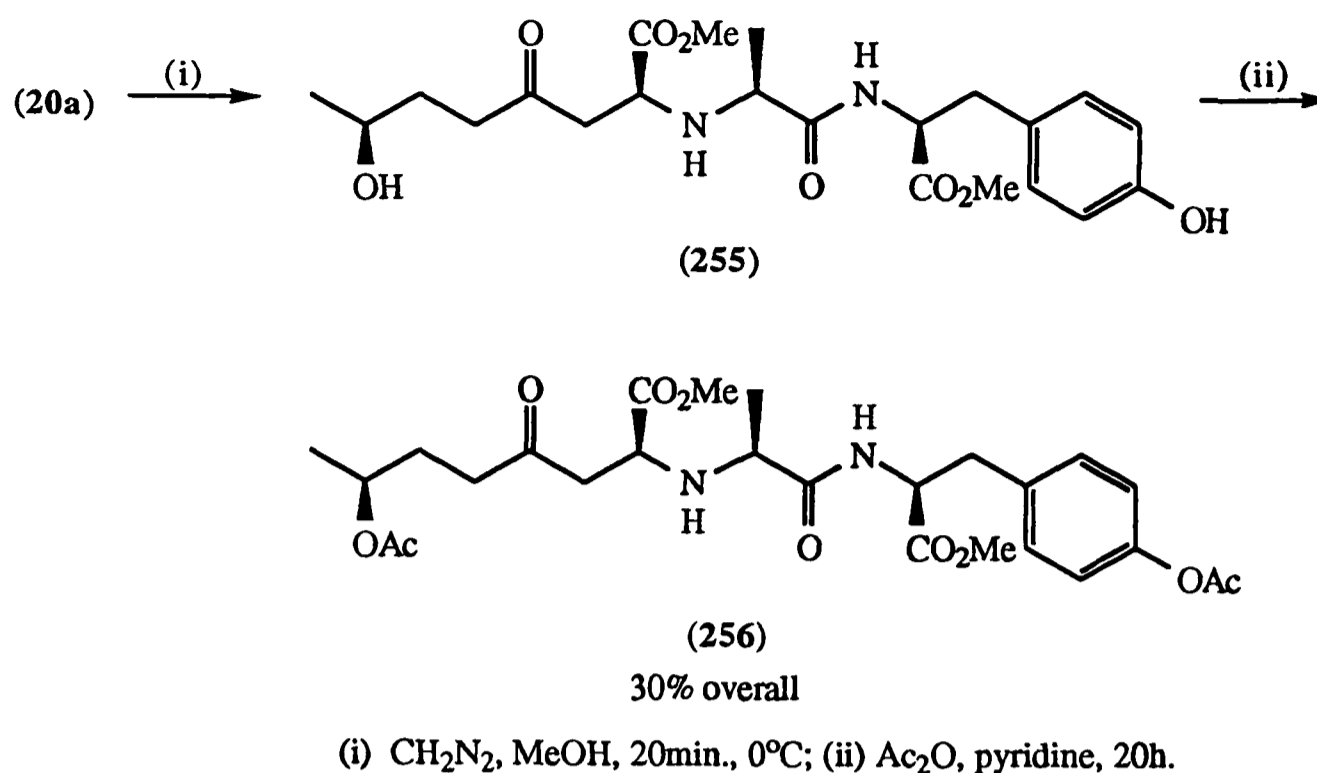

Scheme 84

10.5 Concluding Remarks

In summary a flexible route to optically pure γ -keto α -amino acids using carbon based nucleophilic ring opening of activated monocyclic β -lactams has been established.⁹³ This methodology has been applied to a high yielding synthesis of the naturally occurring potent ACE inhibitor WF-10129 (**20**)¹⁵ whose stereochemistry has been assigned by total synthesis to be *S* at all stereocentres. In addition the route to (**20**) is flexible with respect to the preparation of analogues.

Chapter 11

Experimental for Part II

See Part I, page 119 for general experimental techniques.

11.1 Experimental Procedures

(L)-Aspartic dibenzyl ester *p*-toluenesulfonate (153)⁹⁵

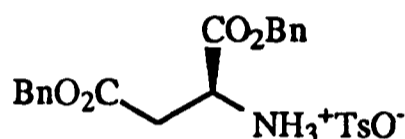

To a stirred suspension of (*L*)-aspartic acid (40.7g, 0.30mol.) and *p*-toluenesulfonic acid monohydrate (62.7g, 0.33mol.) in benzene (60ml) was added benzyl alcohol (120ml) and the reaction was refluxed, with the liberated water being removed azeotropically and trapped with the aid of a Dean and Stark distilling receiver, for eighteen hours after which time no more water was collected. The reaction was then allowed to cool to room temperature and diluted with benzene (250ml) and anhydrous ether (400ml). Standing for two hours at 4°C afforded (*L*)-aspartic acid dibenzyl ester *p*-toluenesulfonate (153) as a white crystalline solid which was filtered, washed with anhydrous ether and recrystallised (methanol:ether) (123.68g, 85%), m.p. 159-161°C (from methanol:ether) (lit.⁹⁵ 158-160°C); $[\alpha]_D +1.0$ (*c* 1.0 in MeOH) (lit.⁹⁵ + 1.0 (*c* 1.5 in MeOH)); ν_{\max} (FT IR, KBr disc) 3000br m (NH), 1759s (C=O), 1736s (C=O), 1394m, 1184s, 1126s, 1011s and 750s cm^{-1} ; δ_H (200MHz; CDCl_3) 2.28 (3H, s, $(\text{C}_6\text{H}_4)\text{CH}_3$), 3.05 (1H, dd, J 5Hz, J 18Hz, 1 x $\text{CHCH}_2\text{CO}_2\text{CH}_2(\text{C}_6\text{H}_5)$), 3.20 (1H, dd, J 4Hz, J 18Hz, 1 x $\text{CHCH}_2\text{CO}_2\text{CH}_2(\text{C}_6\text{H}_5)$), 4.48 (1H, m, $\text{CHCH}_2\text{CO}_2\text{CH}_2(\text{C}_6\text{H}_5)$), 4.93 (2H, s, $\text{CH}_2\text{CO}_2\text{CH}_2(\text{C}_6\text{H}_5)$), 5.00 and 5.07 (2H, ABq, J 12Hz, $\text{CHCO}_2\text{CH}_2(\text{C}_6\text{H}_5)$) and 7.17-7.30 (14H, m, $\text{CH}_2\text{CO}_2\text{CH}_2(\text{C}_6\text{H}_5)$).

CHCO₂CH₂(C₆H₅) and (C₆H₄)CH₃); δ_C (50MHz; CDCl₃) 21.18 ((C₆H₄)CH₃), 33.75 (CH₂CO₂CH₂(C₆H₅), 49.61 (CHCH₂CO₂CH₂(C₆H₅), 67.12 and 68.21 (CH₂CO₂CH₂(C₆H₅) and CHCO₂CH₂(C₆H₅)), 126.34, 128.63 and 129.06 (aromatic CH), 134.82, 135.42, 141.76 and 141.76 (4 x aromatic ipso C) and 168.37 and 170.13 (CH₂CO₂CH₂(C₆H₅) and CHCO₂CH₂(C₆H₅)); m/z (desorption chemical ionisation, NH₃) 314[(M-TsO)⁺, 100%], 178[30], 108[12] and 91[36].

(L)-Dibenzyl aspartate (154)⁹⁸

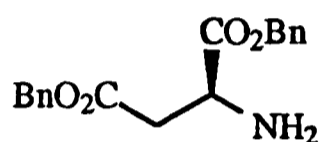

To a stirred solution of (*L*)-Aspartic dibenzyl ester *p*-toluenesulfonate (**153**) (88.01g, 0.18mol.) in water (400ml) was added K₂CO₃ (90g, 0.60mol.) and the mixture was stirred for ten minutes. The resulting solution was then extracted with ethylacetate (3 x 300ml). The organic layers were combined, washed with saturated brine (600ml), dried (MgSO₄), filtered and concentrated *in vacuo* to yield (*L*)-dibenzyl aspartate (**154**) as a pale yellow oil (56.80g, quant.), R_f 0.4 (P.E. 30-40:ether; 50:50); δ_H (200MHz; CDCl₃) 1.76 (2H, br s, NH), 2.78 (1H, dd, *J* 7Hz, *J* 16Hz, 1 x CHCH₂CO₂CH₂(C₆H₅)), 2.90 (1H, dd, *J* 5Hz, *J* 16Hz, 1 x CHCH₂CO₂CH₂(C₆H₅)), 3.89 (1H, dd, *J* 5Hz, *J* 7Hz, CHCH₂CO₂CH₂(C₆H₅)), 5.12 and 5.15 (2 x 2H, 2 x s, 2 x CO₂CH₂(C₆H₅)) and 7.30-7.40 (10H, m, 2 x CO₂CH₂(C₆H₅)).

(4S)-Benzylazetidin-2-one-4-carboxylate (156)⁹⁸

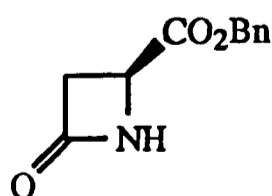

To a stirred solution of (*L*)-dibenzyl aspartate (**154**) (56.70g, 0.18mol.) in anhydrous ether (400ml), under an inert atmosphere of argon, and cooled to 0°C was added

dropwise over ten minutes trimethylchlorosilane (27.8ml, 0.22mol.) resulting in the formation of a white suspension. After stirring for thirty minutes at 0°C, triethylamine (30.5ml, 0.22mmol.) was added resulting in the formation of a thick white precipitate. The mixture was stirred for a further one hour at 0°C before being filtered under argon into a three neck flask fitted with a mechanical stirrer, the temperature being maintained at 0°C. $t\text{BuMgCl}$ (100ml of a 2M solution in ether, 0.19mmol.) was then added slowly *via* a cannula resulting in the formation of a white suspension in a yellow solution. The mixture was then warmed to room temperature and stirred for twelve hours after which it was recooled to 0°C and 2M HCl saturated with NH_4Cl (350ml) was added carefully. The organic layer was removed and the aqueous layer washed with dichloromethane (3 x 500ml). The organic fractions were combined and washed with saturated aqueous NaHCO_3 (2 x 500ml) and saturated aqueous brine (1litre), dried (MgSO_4), filtered and concentrated *in vacuo* to afford (4*S*)-benzylazetid-2-one-4-carboxylate (156) as a white crystalline solid which was recrystallised from P.E. 30-40:dichloromethane (25.6g, 69%), m.p. 139-141°C (lit.⁹⁶ 141-143°C (from chloroform)), (R_f 0.3, P.E 30-40:ethylacetate; 50:50), (Found: C, 64.25; H, 5.57; N, 6.83. $\text{C}_{11}\text{H}_{11}\text{NO}_3$ requires C, 64.39; H, 5.40; N, 6.82%); $[\alpha]_D -42.1$ (c 1.0 in CHCl_3) (lit.⁹⁶ -43.4 (c 3.28 in CHCl_3)); ν_{max} (FT IR, KBr disc) 3202 br s (NH), 1773s (C=O), 1735s (C=O), 1193s, 1171s, 955s, 742s and 675s cm^{-1} ; δ_{H} (200MHz; CDCl_3) 3.10 (1H, ddd, J 2Hz, J 3Hz, J 15Hz, 1 x CH_2CH), 3.32 (1H, ddd, J 2Hz, J 6Hz, J 15Hz, 1 x CH_2CH) 4.22 (1H, dd, J 3Hz, J 6Hz, CH_2CH), 5.21 (2H, s, $\text{CO}_2\text{CH}_2(\text{C}_6\text{H}_5)$), 6.37 (1H, br s, NH) and 7.30-7.40 (5H, m, $\text{CO}_2\text{CH}_2(\text{C}_6\text{H}_5)$); δ_{C} (50MHz; CDCl_3) 43.44 (CH_2CH), 47.25 (CH_2CH), 67.46 ($\text{CO}_2\text{CH}_2(\text{C}_6\text{H}_5)$), 128.67 and 128.93 (aromatic CH), 135.14 (aromatic *ipso* C) and 166.87 and 171.30 ($\text{CO}_2\text{CH}_2(\text{C}_6\text{H}_5)$ and $\text{C}(\text{O})\text{CH}_2\text{CH}$); m/z (chemical ionisation, NH_3) 223[(MNH_4)⁺, 85%], 206[(MH)⁺, 33], 178[49], 108[24], 91[100], 70[17] and 44[10].

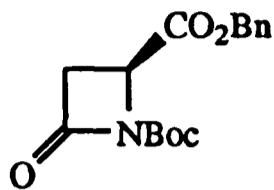
(4S)-Benzyl N-(*t*-butoxycarbonyl)azetidin-2-one-4-carboxylate (145)

To a stirred solution of (4S)-benzylazetidin-2-one-4-carboxylate (156) (1.00g, 4.87mmol.) in anhydrous acetonitrile (20ml), under an inert atmosphere of argon, was added di-*t*-butyldicarbonate (2.13g, 9.74mmol.) and DMAP (59mg, 0.48mmol.). The mixture was stirred at room temperature for seventeen hours before being concentrated *in vacuo*. The resulting residue was dissolved in dichloromethane (100ml) and washed with 1M KHSO₄ (40ml), saturated aqueous NaHCO₃ (40ml) and saturated aqueous brine (40ml), dried (MgSO₄), filtered and concentrated *in vacuo* to yield a yellow oil. Flash chromatography (SiO₂, P.E 30-40:ether; 60:40) afforded (4S)-benzyl N-(*t*-butoxycarbonyl)azetidin-2-one-4-carboxylate (145) as a colourless oil which solidified on standing (1.40g, 94%), m.p. 55-57°C (from P.E. 30-40:ether), (R_f 0.3, P.E 30-40:ether; 60:40), (Found: C, 62.93; H, 6.30; N, 4.44. C₁₆H₁₉NO₅ requires C, 62.95; H, 6.27; N, 4.59%); [α]_D -74.5 (c 1.0 in CHCl₃); ν_{max} (FT IR, CDCl₃ solution, NaCl plates) 2981br m (NH), 1821s (C=O), 1729s (C=O), 1337s, 1155s, 1047s and 736s cm⁻¹; δ_H (200MHz; CDCl₃) 1.46 (9H, s, NHCO₂C(CH₃)₃), 2.99 (1H, dd, *J* 3Hz, *J* 16Hz, 1 x CH₂CH), 3.25 (1H, dd, *J* 6Hz, *J* 16Hz, 1 x CH₂CH), 4.43 (1H, dd, *J* 3Hz, *J* 6Hz, CH₂CH), 5.23 and 5.27 (2H, ABq, *J* 12Hz, CHCO₂CH₂(C₆H₅)) and 7.30-7.40 (5H, m, CHCO₂CH₂(C₆H₅)); δ_C (50MHz; CDCl₃) 27.74 (NHCO₂C(CH₃)₃), 41.23 (CH₂CH), 49.58 (CH₂CH), 67.60 (CHCO₂CH₂(C₆H₅)), 84.05 (NHCO₂C(CH₃)₃), 128.71 and 128.89 (aromatic CH), 135.04 (aromatic *ipso* C), 147.07 (NHCO₂C(CH₃)₃) and 162.53 and 169.43 (CHCO₂CH₂(C₆H₅) and C(O)CH₂CH); m/z (desorption chemical ionisation, NH₃) 323[(MNH₄)⁺, 15%], 223[100], 206[13], 178[15], 108[38], 91[75] and 57[14].

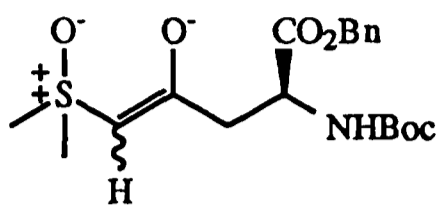
(2*S*, 5*RS*)-Benzyl *N*-(*t*butoxycarbonyl)-2-amino-4-oxo-5-dimethylsulfoxonilide (149)⁹⁴

To a stirred solution of sodium hydride (47mg, 1.98mmol.) in anhydrous DMSO (10ml), under an inert atmosphere of argon, was added trimethylsulfoxonium iodide (516mg, 2.35mmol.) The mixture was stirred at room temperature for ninety minutes and then (4*S*)-benzyl *N*-(*t*butoxycarbonyl)azetidin-2-one-4-carboxylate (145) (550mg, 1.80mmol.) was added as a solution in anhydrous DMSO (10ml). The resulting mixture was stirred at room temperature for a further ten minutes, then diluted with ethylacetate (60ml) and washed with H₂O (2 x 50ml). The aqueous layer was back extracted with ethylacetate (2 x 60ml) and the organic layers were combined, washed with H₂O (2 x 50ml), dried (MgSO₄), filtered and concentrated *in vacuo* to afford (2*S*, 5*RS*)-benzyl *N*-(*t*butoxycarbonyl)-2-amino-4-oxo-5-dimethylsulfoxonilide (149) as a pale yellow foam (710mg, 99%), (R_f 0.1, ethylacetate); [α]_D -11.2 (*c* 3.0 in CHCl₃); ν_{max} (FT IR, Thin film, NaCl plates) 2983m, 1744m (C=O), 1718s (C=O), 1559s, 1496s, 1394s, 1291m, 1167s, 927s, 916s and 889s cm⁻¹; δ_H (200MHz; CDCl₃) 1.44 (9H, s, NHCO₂C(CH₃)₃), 2.65 (1H, dd, *J* 6Hz, *J* 15Hz, 1 x CH₂CH), 2.82 (1H, dd, *J* 5Hz, *J* 15Hz, 1 x CH₂CH), 3.22 and 3.34 (2 x 3H, 2 x s, S(CH₃)₂), 4.31 (1H, s, CHS(CH₃)₂), 4.51 (1H, ddd, *J* 5Hz, *J* 6Hz, *J* 8Hz, CH₂CH), 5.12 and 5.23 (2H, ABq, *J* 13Hz, CHCO₂CH₂(C₆H₅)), 5.95 (1H, d, *J* 8Hz, NH) and 7.30-7.39 (5H, m, CHCO₂CH₂(C₆H₅)); δ_C (50MHz; CDCl₃) 28.18 (NHCO₂C(CH₃)₃), 41.05 (CH₂CH), 41.66 and 41.81 (S(CH₃)₂), 50.97 (CH₂CH), 66.74 (CHCO₂CH₂(C₆H₅), 70.61 (CHS(CH₃)₂), 79.54 (NHCO₂C(CH₃)₃), 128.23 and 128.59 (aromatic CH), 135.97 (aromatic *ipso* C), 155.92 (NHCO₂C(CH₃)₃), 172.32 (CHCO₂CH₂(C₆H₅)) and 186.44 (C(O)CH₂CH); *m/z* (chemical ionisation, NH₃) 398[(MH)⁺, 11%], 324[10], 283[12], 266[21], 222[85], 207[15], 108[10], 96[28] and 79[100].

(2*S*, 5*RS*)-Benzyl *N*-(*t*butoxycarbonyl)-2-amino-5-iodo-4-oxohexanoate (158) and (2*S*)-Benzyl *N*-(*t*butoxycarbonyl) 2-amino-4-oxopentanoate (159) Method 1⁹⁴

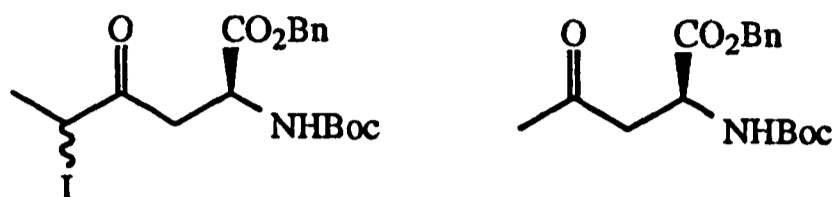

To a stirred solution of (2*S*, 5*RS*)-benzyl *N*-(*t*butoxycarbonyl)-2-amino-4-oxo-5-dimethylsulfoxonilide (149) (300mg, 0.76mmol.) in anhydrous DMF (5ml) was added methyl iodide (1ml) through a plug of alumina, followed by a piece of copper metal. The reaction mixture was stirred at room temperature for forty-eight hours before being diluted with ethylacetate (100ml) and washed with water (2 x 30ml), 0.5M Na₂S₂O₅ (30ml), H₂O (30ml) and saturated aqueous brine (30ml). The organic layer was dried (MgSO₄), filtered and concentrated *in vacuo* to yield a yellow oil. Flash chromatography (SiO₂, P.E. 30-40:ether; 70:30; 50:50; gradient elution) afforded (2*S*, 5*RS*)-benzyl *N*-(*t*butoxycarbonyl)-2-amino-5-iodo-4-oxohexanoate (158) as a yellow oil (216mg, 62%), (R_f 0.3, P.E. 30-40:ether; 50:50); ν_{\max} (FT IR, Thin film, NaCl plates) 3351br s (NH), 2978s, 1755s (C=O), 1710s (C=O) 1500s, 1456s, 1392s, 1368s, 1342s, 1285s, 1166s, 911s and 734s cm⁻¹; δ_{H} (200MHz; CDCl₃) 1.43 and 1.45 (9H, 2 x s, NHCO₂C(CH₃)₃), 1.84 and 1.86 (3H, 2 x d, 2 x *J* 6Hz, CH(I)CH₃), 3.10-3.72 (2H, m, COCH₂CH), 4.51-4.68 (2H, m, CH₂CH and CH(I)CH₃), 5.18 and 5.21 (2H, ABq, *J* 15Hz, CHCO₂CH₂(C₆H₅), 5.42-5.60 (1H, m, NH) and 7.36 (5H, s, CHCO₂CH₂(C₆H₅)); δ_{C} (50MHz; CDCl₃) 21.16 and 21.30 (CH(I)CH₃), 23.53 and 23.90 (CH(I)CH₃), 28.27 and 23.34 (NHCO₂C(CH₃)₃), 40.33 and 40.39 (CH₂CH), 49.80 and 49.96 (CH₂CH), 67.38 and 67.47 (CHCO₂CH₂(C₆H₅)), 80.04 and 80.13 (NHCO₂C(CH₃)₃), 128.27, 128.37 and 128.51 (aromatic CH), 135.14 and 135.20 (aromatic *ipso* C), 155.34 (NHCO₂C(CH₃)₃), 170.89 and 171.10 (CHCO₂CH₂(C₆H₅)) and 202.81 and 202.92 (C(O)CH₂(I)CH₃); *m/z* (desorption chemical ionisation, NH₃) 479[(MNH₄)⁺, 4%], 462[(MH)⁺, 21], 406[22], 362[30], 336[10], 326[8], 280[8], 236[26], 108[25], 100[21], 91[100], 70[11], 65[10] and 57[20] and (2*S*)-benzyl *N*-

(*t*-butoxycarbonyl) 2-amino-4-oxopentanoate (159) (27mg, 11%) which had identical physical and spectroscopic properties to (159) prepared by method 2 below.

(2*S*)-Benzyl *N*-(*t*-butoxycarbonyl) 2-amino-4-oxohexanoate (164)⁹⁴ and (2*S*)-Benzyl *N*-(*t*-butoxycarbonyl)-2-amino-4-oxopentanoate (159), Method 2

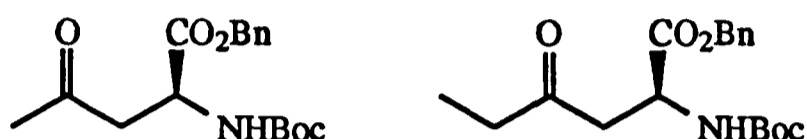

To a stirred solution of (2*S*, 5*RS*) benzyl *N*-(*t*-butoxycarbonyl) 2-amino-4-oxo-5-dimethylsulfoxonilide (149) (241mg, 0.61mmol.) in anhydrous DMF (5ml) was added methyl iodide (1ml) through a plug of alumina, followed by a piece of copper metal. The reaction mixture was stirred at room temperature for forty eight hours before being diluted with ethylacetate (80ml) and washed with water (2 x 30ml), 0.5M Na₂S₂O₅ (30ml), H₂O (30ml) and saturated aqueous brine (30ml). The organic layer was dried (MgSO₄), filtered and concentrated *in vacuo* to yield a yellow oil. To a stirred solution of this yellow oil in acetic acid (5ml) was added activated zinc powder (80mg). The mixture was stirred at room temperature for one hour and then filtered through a silica plug and concentrated *in vacuo* to yield a yellow oil. Flash chromatography (SiO₂, P.E. 30-40:ether; 70:30; 50: 50; gradient elution) afforded (2*S*)-benzyl *N*-(*t*-butoxycarbonyl)-2-amino-4-oxo hexanoate (164) as a yellow oil (61mg, 30%), (R_f 0.5, P.E 30-40:ether; 50:50); [α]_D +14.0 (c 1.0 in CH₂Cl₂) (lit.⁶⁶ +13.4 (c 1.0 in CH₂Cl₂); ν_{max} (FT IR, Thin film, NaCl plates) 3373br m (NH), 2978m, 1740s (C=O), 1500s, 1368s, 1167s and 735s cm⁻¹; δ_H (200MHz; CDCl₃) 1.02 (3H, t, *J* 7Hz, CH₂CH₃), 1.43 (9H, s, NHCO₂C(CH₃)₃), 2.40 (2H, q, *J* 7Hz, CH₂CH₃), 2.93 (1H, dd, *J* 4Hz, *J* 18Hz, 1 x CH₂CH), 3.18 (1H, dd, *J* 5Hz, *J* 18Hz, 1 x CH₂CH), 4.56 (1H, ddd, *J* 4Hz, *J* 5Hz, *J* 8Hz, CH₂CH), 5.10 and 5.20 (2H, ABq, *J* 13Hz, CHCO₂CH₂(C₆H₅)), 5.57 (1H, d, *J* 8Hz, NH) and 7.35 (5H, s, CHCO₂CH₂(C₆H₅)); δ_C (50MHz; CDCl₃) 7.30 (CH₂CH₃), 28.15 (NHCO₂C(CH₃)₃), 35.83 (CH₂CH₃), 43.90 (CH₂CH), 49.59 (CH₂CH), 67.23 (CHCO₂CH₂(C₆H₅)), 80.04 (NHCO₂C(CH₃)₃),

128.35, 128.52 and 128.72 (aromatic $\underline{\text{C}}\text{H}$), 135.61 (aromatic *ipso* $\underline{\text{C}}$), 156.00 ($\text{NH}\underline{\text{C}}\text{O}_2\text{C}(\text{CH}_3)_3$), 171.68 ($\text{CH}\underline{\text{C}}\text{O}_2\text{CH}_2(\text{C}_6\text{H}_5)$) and 209.00 ($\underline{\text{C}}(\text{O})\text{CH}_2\text{CH}_3$); m/z (chemical ionisation, NH_3) 353 [$(\text{MNH}_4)^+$, 11%], 336 [$(\text{MH})^+$, 18], 297[32], 280[74], 236[100], 200[9], 144[9], 108[17], 100[63], 91[38] and 57[9] and (2*S*)-benzyl *N*-(*t*-butoxycarbonyl)-2-amino-4-oxopentanoate (159) as a yellow oil (39mg, 20%), (R_f 0.45, P.E 30-40:ether; 50:50); $[\alpha]_D +13.9$ (c 1.0 in CH_2Cl_2) (lit.⁶⁶ +14.5 (c 1.0 in CH_2Cl_2); ν_{max} (FT IR, Thin film, NaCl plates) 3373br m (NH), 2978m, 1740s (C=O), 1718s, 1500s, 1368s, 1167s and 735s cm^{-1} ; δ_{H} (200MHz; CDCl_3) 1.44 (9H, s, $\text{C}(\underline{\text{C}}\text{H}_3)_3$), 2.15 (3H, s, $\text{C}(\text{O})\underline{\text{C}}\text{H}_3$), 2.96 (1H, dd, J 4Hz, J 17Hz, 1 x $\underline{\text{C}}\text{H}_2\text{CH}$), 3.17 (1H, dd, J 3Hz, J 17Hz, 1 x $\underline{\text{C}}\text{H}_2\text{CH}$), 4.57 (1H, ddd, J 3Hz, J 4Hz, J 8Hz, $\underline{\text{C}}\text{H}_2\text{CH}$) 5.52 (1H, d, J 8Hz, $\underline{\text{N}}\text{H}$) and 7.36 (5H, s, $\text{CH}_2(\underline{\text{C}}_6\text{H}_5)$); δ_{C} (50MHz; CDCl_3) 28.10 ($\text{NH}\underline{\text{C}}\text{O}_2\text{C}(\underline{\text{C}}\text{H}_3)_3$), 29.71 ($\text{C}(\text{O})\underline{\text{C}}\text{H}_3$), 45.21 ($\underline{\text{C}}\text{H}_2\text{CH}$), 49.51 ($\text{CH}_2\underline{\text{C}}\text{H}$), 67.25 ($\text{CH}\underline{\text{C}}\text{O}_2\underline{\text{C}}\text{H}_2(\text{C}_6\text{H}_5)$), 80.01 ($\text{NH}\underline{\text{C}}\text{O}_2\underline{\text{C}}(\text{CH}_3)_3$), 128.26, 128.45 and 128.66 (aromatic $\underline{\text{C}}\text{H}$), 135.40 (aromatic *ipso* $\underline{\text{C}}$), 155.50 ($\text{NH}\underline{\text{C}}\text{O}_2\text{C}(\text{CH}_3)_3$), 171.10 ($\underline{\text{C}}\text{O}_2\text{CH}_2(\text{C}_6\text{H}_5)$) and 206.10 ($\underline{\text{C}}(\text{O})\text{CH}_2$); m/z (chemical ionisation, NH_3) 322[(MH)⁺, 15%], 283[40], 266[55], 222[100], 186[11], 108[17], 91[36] and 86[85].

(4*S*)-Azetidin-2-one-4-carboxylic acid (182)

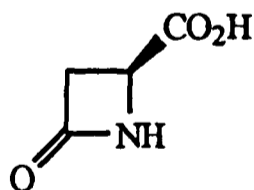

To a stirred solution of 10% Pd/C (cat.) in THF (20ml) was added (4*S*)-benzylazetidin-2-one-4-carboxylate (156) (1.00g, 4.88mmol.) as a solution in THF (10ml). The mixture was then stirred for fourteen hours under an atmosphere of hydrogen before being filtered through Celite[®] and concentrated *in vacuo* to afford (4*S*)-azetidin-2-one-4-carboxylic acid (182) as a white crystalline solid (552mg, 98%), m.p. 99-100°C (from P.E.30-40:ethylacetate), (Found: C, 56.14; H, 7.98; N, 8.08. $\text{C}_4\text{H}_5\text{NO}_3$ requires C, 56.13; H, 7.65; N, 8.18%); $[\alpha]_D -115.0$ (c 1.0 in H_2O); ν_{max} (FT IR, KBr disc) 3338br s (NH and

OH), 1747s (C=O), 1725s (C=O), 1421s, 1262s, 1213s, 1196s, 1167s, 1044s, 864s, 805s, 646s and 625s cm^{-1} ; δ_{H} (200MHz; D_2O) 2.84 (1H, dd, J 2.5Hz, J 16Hz, 1 x CH_2CH), 3.15 (1H, dd, J 6Hz, J 16Hz, 1 x CH_2CH) and 4.10 (1H, dd, J 2.5Hz, J 6Hz, CH_2CH); δ_{C} (50MHz; D_2O) 41.72 (CH_2CH), 46.98 (CH_2CH), 170.91 (CO_2H) and 175.41 (C(O)CH_2); m/z (chemical ionisation, NH_3) 133[(MNH_4)⁺, 100%], 122[9], 118[8], 88[20], 70[9] and 55[19].

(4S)-^tButylazetidin-2-one-4-carboxylate (183)

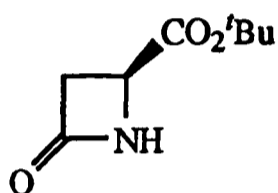

To a stirred suspension of (4S)-azetidin-2-one-4-carboxylic acid (**182**) (850mg, 7.39mmol.) in anhydrous THF (8ml) and anhydrous cyclohexane (5ml), under an inert atmosphere of argon, was added ^tbutyltrichloroacetimidate (3.20g, 14.74mmol.) as a solution in anhydrous cyclohexane (7ml) followed by dropwise addition of borontrifluoride etherate (260 μl , cat.). The mixture was stirred for twenty-five minutes during which time the reaction became clear and then solid NaHCO_3 (500mg) was added and the mixture stirred for a further ten minutes before being filtered and concentrated *in vacuo*. The residue was then taken up in dichloromethane (50ml) and filtered through a plug of Celite[®] to yield a yellow oil. Flash chromatography (SiO_2 , P.E. 30-40:ether; 80:20) afforded (4S)-^tbutylazetidin-2-one-4-carboxylate (**183**) as a white solid (948mg, 75%), m.p. 89-90 $^\circ\text{C}$ (from P.E.30-40:ether), (R_f 0.25, P.E 30-40:ether; 80:20), (Found: C, 42.02; H, 4.37; N, 12.00. $\text{C}_8\text{H}_{13}\text{NO}_3$ requires C, 41.75; H, 4.38; N, 12.17%); $[\alpha]_{\text{D}}$ -28.0 (c 0.5 in CHCl_3); ν_{max} (FT IR, KBr disc) 3352s (NH), 2975m, 1767s (C=O), 1733s (C=O), 1479m, 1412m, 1370s, 1285s, 1247s, 1157s, 1053s, 844s, 759m and 605s cm^{-1} ; δ_{H} (200MHz; CDCl_3) 1.50 (9H, s, $\text{CHCO}_2\text{C}(\text{CH}_3)_3$), 3.05 (1H, ddd, J 2Hz, J 5Hz, J 15Hz, 1 x CH_2CH), 3.21 (1H, ddd, J 1Hz, J 6Hz, J 15Hz, 1 x CH_2CH), 4.08 (1H, dd, J 5Hz, J 6Hz, CH_2CH) and 6.12 (1H, d,

J 1Hz, NH); δ_C (50MHz; $CDCl_3$) 27.79 ($CHCO_2C(CH_3)_3$), 43.28 (CH_2CH), 47.87 (CH_2CH), 82.63 ($CHCO_2C(CH_3)_3$), 167.30 ($CHCO_2C(CH_3)_3$) and 170.60 ($C(O)CH_2CH$); m/z (chemical ionisation, NH_3) 189[(MNH_4)⁺, 100%], 172[(MH)⁺, 20], 144[22], 133[44], 88[11], 74[10], 70[11] and 61[13].

(4*S*)-*t*-Butyl *N*-(*t*-butoxycarbonyl)azetidin-2-one-4-carboxylate (184)

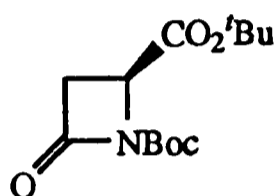

To a stirred solution of (4*S*)-*t*-butylazetidin-2-one-4-carboxylate (183) (1.00g, 5.85mmol.) in anhydrous acetonitrile (15ml), under an inert atmosphere of argon, was added di-*t*-butyldicarbonate (2.55g, 11.70mmol.) as a solution in anhydrous acetonitrile (10ml) followed by DMAP (71mg, 0.58mmol.). The reaction mixture was stirred at room temperature for twenty-four hours before being concentrated *in vacuo*. The residue was taken up in dichloromethane (100ml) and washed with 1M aqueous $KHSO_4$ (2 x 50ml), saturated aqueous $NaHCO_3$ (50ml) and saturated aqueous brine (50ml), dried ($MgSO_4$), filtered and concentrated *in vacuo* to yield a yellow oil. Flash chromatography (SiO_2 , P.E. 30-40:ether; 60:40) afforded (4*S*)-*t*-butyl *N*-(*t*-butoxycarbonyl)azetidin-2-one-4-carboxylate (184) as a colourless oil which solidified on standing (1.42g, 90%), m.p. 45-47°C (from P.E.30-40:ether), (R_f 0.5, P.E 30-40:ether; 50:50), (Found: C, 57.68; H, 7.88; N, 5.41. $C_{13}H_{21}NO_5$ requires C, 57.55; H, 7.80; N, 5.16%); $[\alpha]_D -52.0$ (c 0.65 in $CHCl_3$); ν_{max} (FT IR, $CDCl_3$ solution, NaCl plates) 2984m, 2259m, 1817s (β -lactam C=O), 1729s (ester and carbamate C=O), 1477s, 1396s, 1371s, 1338s, 1258s, 1152s, 1048s, 1000s, 840s and 774s cm^{-1} ; δ_H (200MHz; $CDCl_3$) 1.40 and 1.51 (2 x 9H, 2 x s, $CHCO_2C(CH_3)_3$ and $NHCO_2C(CH_3)_3$), 2.92 (1H, dd, J 3Hz, J 16Hz, 1 x CH_2CH), 3.23 (1H, dd, J 6Hz, J 16Hz, 1 x CH_2CH) and 4.36 (1H, dd, J 3Hz, J 6Hz, CH_2CH); δ_C (50MHz; $CDCl_3$) 27.69 ($CHCO_2C(CH_3)_3$ and $NHCO_2C(CH_3)_3$), 41.10 (CH_2CH), 50.32 (CH_2CH), 82.73 and

83.54 ($\text{NHCO}_2\text{C}(\text{CH}_3)_3$ and $\text{CHCO}_2\text{C}(\text{CH}_3)_3$), 146.91 ($\text{NHCO}_2\text{C}(\text{CH}_3)_3$), 162.99 ($\text{CHCO}_2\text{C}(\text{CH}_3)_3$) and 168.45 ($\text{C}(\text{O})\text{CH}_2\text{CH}$); m/z (chemical ionisation, NH_3) 289[(MNH_4)⁺, 30%], 233[15], 189[100], 172[7], 144[12], 133[35], 74[8] and 57[42].

(4S)-^tButyl N-(benzyloxycarbonyl)azetidin-2-one-4-carboxylate (203)

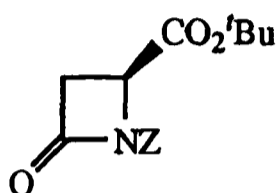

To a stirred solution (4S)-^tbutylazetidin-2-one-4-carboxylate (**183**) (828mg, 4.84mmol.) in anhydrous acetonitrile (5ml), under an inert atmosphere of argon, was added dibenzylidene carbonate (2.77g, 9.68mmol.) as a solution in anhydrous acetonitrile (7ml) followed by DMAP (59mg, 0.48mmol.). The reaction mixture was stirred at room temperature for fifteen minutes before being concentrated *in vacuo*. The residue was dissolved in dichloromethane (70ml) and washed with 1M aqueous KHSO_4 (2 x 30ml), saturated aqueous NaHCO_3 (30ml) and saturated aqueous brine (30ml), dried (MgSO_4), filtered and concentrated *in vacuo* to yield a yellow oil. Flash chromatography (SiO_2 , P.E. 30-40:ether; 70:30; 40:60; gradient elution) afforded (4S)-^tbutyl N-(benzyloxycarbonyl)azetidin-2-one-4-carboxylate (**203**) as a white crystalline solid (1.44g, 97%), m.p. 82-83°C (from P.E. 30-40:ether), (R_f 0.2, P.E. 30-40:ether; 70:30), (Found: C, 62.89; H, 6.12; N, 4.41. $\text{C}_{16}\text{H}_{19}\text{NO}_5$ requires C, 62.94; H, 6.27; N, 4.59%); $[\alpha]_D -86.9$ (c 1.0 in CHCl_3); ν_{max} (FT IR, KBr disc) 2361m, 2343s, 1808s (C=O), 1743s (C=O), 1726s (C=O), 1467s, 1397s, 1366s, 1330s, 1316s, 1236s, 1152s, 1044s, 1000s and 771s cm^{-1} ; δ_{H} (200MHz; CDCl_3) 1.43 (9H, s, $\text{CHCO}_2\text{C}(\text{CH}_3)_3$), 2.98 (1H, dd, J 3Hz, J 17Hz, 1 x CH_2CH), 3.30 (1H, dd, J 6Hz, J 17Hz, 1 x CH_2CH), 4.33 (1H, dd, J 3Hz, J 6Hz, CH_2CH), 5.22 and 5.32 (2H, ABq, J 12Hz, $\text{NHCO}_2\text{CH}_2(\text{C}_6\text{H}_5)$) and 7.34-7.42 (5H, m, $\text{NHCO}_2\text{CH}_2(\text{C}_6\text{H}_5)$); δ_{C} (50MHz; CDCl_3) 27.76 ($\text{CHCO}_2\text{C}(\text{CH}_3)_3$), 41.66 (CH_2CH), 50.31 (CH_2CH), 68.28 ($\text{NHCO}_2\text{CH}_2(\text{C}_6\text{H}_5)$), 83.24 ($\text{CHCO}_2\text{C}(\text{CH}_3)_3$), 128.53 and

128.78 (aromatic $\underline{\text{C}}\text{H}$), 135.00 (aromatic *ipso* $\underline{\text{C}}$), 148.20 ($\text{NH}\underline{\text{C}}\text{O}_2\text{CH}_2(\text{C}_6\text{H}_5)$), 162.58 ($\text{CH}\underline{\text{C}}\text{O}_2\text{C}(\text{CH}_3)_3$) and 168.27 ($\underline{\text{C}}(\text{O})\text{CH}_2\text{CH}$); m/z (desorption chemical ionisation, NH_3) 323[(MNH_4)⁺, 100%], 267[80], 250[12], 223[21], 206[81], 108[57] and 91[98].

Methylphenylsulfone (178)¹⁰⁹

To a stirred solution of thioanisole (177) (1.17ml, 10mmol.) in methanol (40ml) at 0°C was added Oxone[®] (18.44g, 30mmol.) as a solution in H_2O (40ml). The resulting cloudy suspension was stirred at room temperature for five hours then diluted with H_2O (150ml) and extracted with CHCl_3 (3 x 100ml). The organic layers were combined, dried (Na_2SO_4), filtered and concentrated *in vacuo* to yield a white solid. Recrystallisation from P.E. 30-40:chloroform afforded *methylphenylsulfone* (178) as a white crystalline solid (1.55g, quant.), m.p. 87-88°C (lit.¹⁰⁹ 88-89°C), (R_f 0.2, P.E 30-40:ether; 50:50), (Found: C, 53.70; H, 5.16 $\text{C}_7\text{H}_8\text{O}_2\text{S}$ requires C, 53.83; H, 5.16%); ν_{max} (FT IR, KBr disc) 3024m (NH), 2927m, 1329s, 1298s, 1147s, 1087s, 1072s, 966s, 790s and 689s cm^{-1} ; δ_{H} (200MHz; CDCl_3) 3.07 (3H, s, $\underline{\text{C}}\text{H}_3$), 7.59-7.68 (3H, m, *para* and *meta* $\text{SO}_2(\text{C}_6\underline{\text{H}}_5)$) and 7.95-7.99 (2H, m, *ortho* $\text{SO}_2(\text{C}_6\underline{\text{H}}_5)$); δ_{C} (50MHz; CDCl_3) 44.37 ($\underline{\text{C}}\text{H}_3$), 127.44, 129.58 and 133.95 (aromatic $\underline{\text{C}}\text{H}$) and 140.72 (aromatic *ipso* $\underline{\text{C}}$); m/z (chemical ionisation, NH_3) 174[(MNH_4)⁺, 100%], 157[(MH)⁺, 5], 141[7], 94[43], 77[9] and 65[4].

ⁿButylphenylsulfone (189)



To a stirred solution of methylphenylsulfone (178) (200mg, 1.28mmol.) in anhydrous THF (8ml), under an inert atmosphere of argon, cooled to -78°C, ⁿbutyllithium (855 μl of a 1.5M solution in hexanes, 1.28mmol.) was added dropwise. The resulting mixture was warmed to 0°C over one hour and then re-cooled to -78°C. Iodopropane (250ml, 2.56mmol.) was then added. The mixture was allowed to warm to room temperature and then stirred for a further sixteen hours. The reaction was then diluted with dichloromethane

(50ml), washed with saturated aqueous NH_4Cl (20ml), saturated brine (20ml), dried (MgSO_4), filtered and concentrated *in vacuo* to yield a yellow oil. Flash chromatography (SiO_2 , P.E. 30-40:ether; 30:70) afforded *n*butylphenylsulfone (**189**) as a yellow oil (189mg, 55%), (R_f 0.3, P.E. 30-40:ether; 30:70), (Found: C, 60.97; H, 7.48. $\text{C}_{10}\text{H}_{14}\text{O}_2\text{S}$ requires C, 60.58; H, 7.12%); ν_{max} (FT IR, Thin film, NaCl plates) 3065m (NH), 2962s, 2875s, 1586s, 1467s, 1448s, 1406m, 1383s, 1322s, 1157s, 1097s and 799s cm^{-1} ; δ_{H} (200MHz; CDCl_3) 0.80 (3H, t, J 8Hz, CH_3), 1.34-1.50 (2H, m, CH_2CH_3), 1.62-1.74 (2H, m, $\text{CH}_2\text{CH}_2\text{CH}_3$) and 3.08 (2H, m, $\text{CH}_2\text{CH}_2\text{CH}_2\text{CH}_3$), 7.54-7.72 (3H, m, *meta* and *para* $\text{SO}_2(\text{C}_6\text{H}_5)$) and 7.89-7.95 (2H, m, *ortho* $\text{SO}_2(\text{C}_6\text{H}_5)$); δ_{C} (50MHz; CDCl_3) 13.33 (CH_3), 21.31 (CH_2CH_3), 24.46 ($\text{CH}_2\text{CH}_2\text{CH}_3$), 55.91 ($\text{CH}_2\text{CH}_2\text{CH}_2\text{CH}_3$), 128.13, 129.44 and 133.84 (aromatic CH) and 139.34 (aromatic *ipso* C); m/z (GCMS, NH_3) 215[(MNH_4) $^+$, 100%], 199[(MH) $^+$, 21], 132[12], 125[12] and 78[15].

(2*S*)-Benzyl *N*-(*t*butoxycarbonyl)-2-amino-4-oxo-5-phenylsulfonylpentanoate (**179**) and (2*S*)-Dibenzyl *N*-(*t*butoxycarbonyl) aspartic acid (**180**)

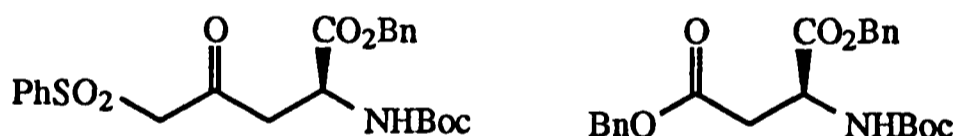

To a stirred solution of methylphenylsulfone (**178**) (102mg, 0.66mmol.) in anhydrous THF (5ml) at -78°C , under an inert atmosphere of argon, was added *n*butyllithium (423 μl of a 1.55M solution, 0.66mmol.). After stirring at -78°C for thirty minutes the mixture was warmed to 0°C and stirred at 0°C for fifteen minutes, before being recooled to -78°C , whereupon (4*S*)-benzyl *N*-(*t*butoxycarbonyl)azetidin-2-one-4-carboxylate (**145**) (200mg, 0.66mmol.) was added as a solution in anhydrous THF (4ml). The reaction mixture was then stirred for a further thirty minutes at -78°C before being quenched by the addition of saturated aqueous NH_4Cl and diluted with ethylacetate. The organic layer was separated and washed with saturated aqueous NH_4Cl and saturated aqueous brine, dried (MgSO_4), filtered and concentrated *in vacuo*.to yield a yellow oil. Flash chromatography (SiO_2 , P.E 30-

40:ether; 50:50) afforded (2*S*)-benzyl *N*-(*t*-butoxycarbonyl)-2-amino-4-oxo-5-phenylsulfonylpentanoate (179) as a white crystalline solid (100mg, 33%), (R_f 0.3, P.E 30-40:ether; 50:50); ν_{max} (FT IR, $CDCl_3$ solution, NaCl plates) 3440br m (NH), 2982m, 1730s (C=O), 1718s (C=O), 1500s, 1328s, 1294s, 1249s, 1160s, 1069s and 704s cm^{-1} ; δ_H (200MHz; $CDCl_3$) 1.48 (9H, s, $NHCO_2C(CH_3)_3$), 3.24-3.45 (2H, m, CH_2CH), 4.16 (2H, s, $CH_2SO_2(C_6H_5)$), 4.55-4.64 (1H, m, CH_2CH), 5.14 and 5.16 (2H, ABq, J 13Hz, $CHCO_2CH_2(C_6H_5)$), 5.35 (1H, d, J 8Hz, NH), 7.35 (5H, s, $CHCO_2CH_2(C_6H_5)$), 7.57-7.72 (3H, m, *meta* and *para* $SO_2(C_6H_5)$) and 7.85-7.89 (2H, m, *ortho* $SO_2(C_6H_5)$); δ_C (50MHz; $CDCl_3$) 22.18 ($NHCO_2C(CH_3)_3$), 46.12 (CH_2CH), 49.43 (CH_2CH), 66.87 and 67.52 ($CH_2SO_2(C_6H_5)$ and $CH_2(C_6H_5)$), 80.34 ($NHCO_2C(CH_3)_3$), 128.40, 128.52, 128.64, 128.80, 129.56 and 131.60 (aromatic CH), 131.66 and 135.36 (2 x aromatic *ipso* C), 155.57 ($NHCO_2C(CH_3)_3$), 171.04 ($CHCO_2CH_2(C_6H_5)$) and 196.73 ($C(O)CH_2SO_2(C_6H_5)$); m/z (chemical ionisation, NH_3) 479[(MNH_4)⁺, 12%], 462[(MH)⁺, 9], 423[16], 362[21], 226[37], 160[20], 108[35], 91[100] and 78[34] and (2*S*)-dibenzyl *N*-(*t*-butoxycarbonyl) aspartic acid (180), (39mg, 15%), m.p.85-88°C, (R_f 0.6, P.E 30-40:ether; 50:50); ν_{max} (FT IR, Thin film, NaCl plates) 3441m, 3036m, 2981m, 2934m, 2259m, 1773s (C=O), 1725s (C=O), 1499s, 1369s and 1167s cm^{-1} ; δ_H (200MHz; $CDCl_3$) 1.40 (9H, s, $NHCO_2C(CH_3)_3$), 2.85 (2H, dd, J 5Hz, J 16Hz, 1 x CH_2CH), 2.94 (1H, dd, J 4Hz, J 16Hz, 1 x CH_2CH), 4.62 (1H, ddd, J 4Hz, J 5Hz, J 8Hz, CH_2CH), 5.06 and 5.12 (2 x 2H, 2 x s, $CHCO_2CH_2(C_6H_5)$ and $CH_2CO_2CH_2(C_6H_5)$), 5.50 (1H, d, J 8Hz, NH) and 7.25-7.40 (10H, m, $CH_2CO_2CH_2(C_6H_5)$ and $CHCO_2CH_2(C_6H_5)$); m/z (chemical ionisation, NH_3) 431[(MNH_4)⁺, 2%], 414[(MH)⁺, 12], 375[50], 358[71], 314[100], 178[70], 108[31] and 91[69].

General procedure for ring opening of β -lactams with metallated sulfones. Preparation of (185), (190), (198), (204), (242a) and (242b)

To a stirred solution of sulfone (178), (189), (197), (241) or (254) (2 eq.) in anhydrous THF (*ca.* 10ml per mmol. of β -lactam) at -78°C, under an inert atmosphere of argon, was added *n*butyllithium (2eq.). After stirring at -78°C for ten minutes the mixture

was warmed to 0°C and stirred at 0°C for ten minutes, before being recooled to -78°C, whereupon β -lactam (184) or (203) was added as a solution in anhydrous THF (*ca.* 5ml per mmol. of β -lactam). The reaction mixture was then stirred for a further thirty minutes at -78°C before being quenched by the addition of saturated aqueous NH₄Cl and diluted with ethylacetate. The organic layer was separated, washed with saturated aqueous NH₄Cl, saturated aqueous brine, dried (MgSO₄), filtered and concentrated *in vacuo*.

(2S)-*t*-Butyl N-(*t*-butoxycarbonyl)-2-amino-4-oxo-5-phenylsulfonylpentanoate (185)

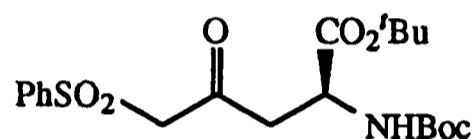

The general procedure with β -lactam (184) (124mg, 0.46mmol) and sulfone (178) followed by flash chromatography (SiO₂, P.E 30-40:ether; 50:50) afforded (2S)-*t*-butyl N-(*t*-butoxycarbonyl)-2-amino-4-oxo-5-phenylsulfonylpentanoate (185) as a white crystalline solid (160mg, 81%), m.p. 171-172°C (from P.E 30-40:ether), (R_f 0.2, P.E 30-40:ether; 60:40), (Found: C, 56.14; H, 6.68; N, 3.18. C₂₀H₂₉NO₇S requires C, 56.19; H, 6.84; N, 3.28%); [α]_D +36.3 (*c* 0.4 in CHCl₃); ν_{\max} (FT IR, KBr disc) 3359m (NH), 2360m, 1733s (C=O), 1707s (C=O), 1654s, 1528s, 1472s, 1448s, 1403s, 1369m, 1340m, 1310s, 1232s, 1050s, 729s and 687s cm⁻¹; δ_{H} (200MHz; CDCl₃) 1.44 and 1.45 (2 x 9H, 2 x s, CHCO₂C(CH₃)₃ and NHCO₂C(CH₃)₃), 3.15-3.37 (2H, m, CH₂CH), 4.16 and 4.19 (2H, ABq, *J* 13Hz, CH₂SO₂(C₆H₅)), 4.38 (1H, m, CH₂CH), 5.42 (1H, d, *J* 8Hz, NH), 7.54-7.73 (3H, m, *meta* and *para* SO₂(C₆H₅)) and 7.80-7.93 (2H, m, *ortho* SO₂(C₆H₅)); δ_{C} (125MHz; CDCl₃) 27.93 and 28.43 (CHCO₂C(CH₃)₃ and NHCO₂C(CH₃)₃), 46.68 (CH₂CH), 50.24 (CH₂CH), 67.08 (CH₂SO₂(C₆H₅)), 80.14 and 82.73 (CHCO₂C(CH₃)₃ and NHCO₂C(CH₃)₃), 128.42, 129.47 and 134.42 (aromatic CH), 138.97 (aromatic *ipso* C), 155.80 (NHCO₂C(CH₃)₃), 169.76 (CHCO₂C(CH₃)₃) and 196.13

(C(O)CH₂SO₂(C₆H₅)); m/z (desorption chemical ionisation, NH₃) 445[(MNH₄)⁺, 12%], 428[(MH)⁺, 5], 389[22], 333[90], 328[13], 272[18], 226[100], 86[45] and 57[49].

(2*S*, 5*RS*, 7*RS*)-^tButyl *N*-(^tbutoxycarbonyl)-2-amino-7-^tbutyldiphenylsilyloxy-4-oxo-5-phenyl sulfonyloctanoate (198)

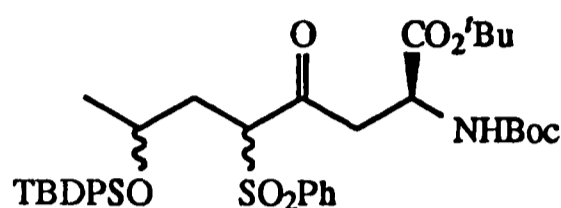

The general procedure with β-lactam (184) (129mg, 0.47mmol.) and sulfone (197) (430mg, 0.95mmol.) followed by flash chromatography (SiO₂, P.E 30-40:ether; 80:20) afforded (2*S*, 5*RS*, 7*RS*)-^tbutyl *N*-(^tbutoxycarbonyl) 2-amino-7-^tbutyldiphenylsilyloxy-4-oxo-5-phenylsulfonyl octanoate (198) as a colourless oil (292mg, 85%), (R_f 0.2, P.E 30-40:ether; 80:20); ν_{max} (FT IR, Thin film, NaCl plates) 3439br m (NH), 2977s, 2932s, 2859s, 1719s (C=O), 1497s, 1449s, 1429s, 1393s, 1369s, 1325s, 1311s, 1253s, 1155s, 1111m, 1085s, 1072s, 911s and 735s cm⁻¹; δ_H (200MHz; CDCl₃) 0.81-0.97 (3H, m, CHCH₃), 0.99, 1.01 and 1.04 (9H, 3 x s, SiC(CH₃)₃), 1.38, 1.40, 1.43 and 1.47 (18H, 4 x s, CHCO₂C(CH₃)₃ and NHCO₂C(CH₃)₃), 1.90-2.13 (2H, m, CH(SO₂(C₆H₅))CH₂), 2.75-2.93 and 3.15-4.04 (3H, 2 x m, CH₂CHCO₂C(CH₃)₃ and CHOSiC(CH₃)₃(C₆H₅)₂), 4.38-4.56 (2H, m, CH₂CHCO₂C(CH₃)₃ and CHSO₂(C₆H₅)₂), 5.12-5.38 (1H, m, NH) and 7.30-7.82 (15H, m, Si(C₆H₅)₂ and SO₂(C₆H₅)); δ_C (125MHz; CDCl₃) 17.04 (SiC(CH₃)₃), 21.07, 21.21, 21.65 and 21.95 (SiC(CH₃)₃), 24.88, 25.73, 26.26 (CHCO₂C(CH₃)₃), NHCO₂C(CH₃)₃ and CH(OSiC(CH₃)₃(C₆H₅)₂)CH₃), 33.35, 33.69, 34.53 and 34.86 (CH₂CHCO₂C(CH₃)₃), 44.27, 44.57 and 44.73 (CH(SO₂(C₆H₅))CH₂), 47.79 (CH₂CHCO₂C(CH₃)₃), 64.20, 65.02, 65.18, 68.78, 69.64 and 70.04 (CHOSiC(CH₃)₃(C₆H₅)₂ and CHSO₂(C₆H₅)), 77.63, 80.00, 80.15 and 81.17 (CHCO₂C(CH₃)₃ and NHCO₂C(CH₃)₃), 125.51, 125.60, 125.74, 126.91, 127.13, 127.27, 127.62, 127.76, 132.05, 133.55 and 133.66 (aromatic CH), 131.45, 131.62,

131.69 and 134.64 (2 x aromatic *ipso* C), 153.18 (NHCO₂C(CH₃)₃), 167.61 and 167.90 (CHCO₂C(CH₃)₃) and 197.50 and 197.96 (C(O)CH₂CH); m/z (desorption chemical ionisation, NH₃) 741[(MNH₄)⁺, 5%], 685[(MH)⁺, 13], 685[40], 666[32], 629[30], 375[30], 266[30], 211[100], 196[30], 160[39], 125[50], 94[23] and 78[63].

(2S)-^tButyl N-(benzyloxycarbonyl)-2-amino-4-oxo-5-phenylsulfonylpentanoate (204)

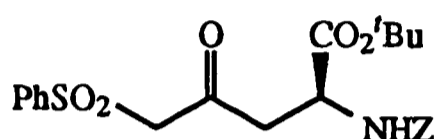

The general procedure with β-lactam (203) (477mg, 1.56mmol.) and sulfone (178) followed by flash chromatography (SiO₂, dichloromethane; dichloromethane:ether; 50:50; gradient elution) afforded (2S)-^tbutyl N-(benzyloxycarbonyl)-2-amino-4-oxo-5-phenylsulfonylpentanoate (204) as a white crystalline solid (60mg, 84%), m.p. 85-86°C (from P.E. 30-40:ether), (R_f 0.1, dichloromethane), (Found: C, 60.06; H, 5.77; N, 2.83. C₂₃H₂₇NO₇S requires C, 59.86; H, 5.90; N, 3.03%); [α]_D +42.4 (c 1.0 in CHCl₃); ν_{max} (FT IR, KBr disc) 3359br s (NH), 2360s, 2342s, 1733s (C=O), 1712s (C=O), 1707s (C=O), 1528s, 1340s, 1151s, 1064s, 1050s and 687s cm⁻¹; δ_H (200MHz; CDCl₃) 1.43 (9H, s, CO₂C(CH₃)₃), 3.30 (1H, dd, J 4.5Hz, J 18Hz, 1 x CH₂CH), 3.40 (1H, dd, J 4.5Hz, J 18Hz, 1 x CH₂CH), 4.17 (2H, ABq, J 15Hz, CH₂SO₂(C₆H₅)), 4.49 (1H, ddd, J 8Hz, J 4.5Hz, J 4.5Hz, CH₂CH), 5.12 (2H, s, CH₂(C₆H₅)), 5.58 (1H, d, J 8Hz, NH), 7.34 (5H, s, CH₂(C₆H₅)) and 7.48-7.90 (5H, m, SO₂(C₆H₅)); δ_C (125MHz; CDCl₃) 27.82 (CO₂C(CH₃)₃), 46.42 (CH₂CH), 50.59 (CH₂CH), 67.07 and 67.09 (CH₂SO₂(C₆H₅) and CH₂(C₆H₅)), 82.90 (CO₂C(CH₃)₃), 128.10, 128.19, 128.28, 128.54 and 129.37 (aromatic CH), 134.29 and 136.34 (2 x aromatic *ipso* C), 155.90 (NHCO₂CH₂(C₆H₅)), 169.24 (CO₂C(CH₃)₃) and 195.80 (C(O)CH₂SO₂(C₆H₅)); m/z (desorption chemical ionisation, NH₃) 479[(MNH₄)⁺, 15%], 423[43], 406[12], 362[18], 316[19], 271[9], 226[10], 175[8], 160[9], 112[10], 108[39], 91[100], 78[9] and 57[6].

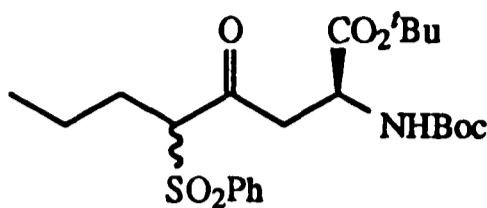
(2*S*, 5*RS*)-*t*-Butyl *N*-(*t*-butoxycarbonyl)-2-amino-4-oxo-5-phenylsulfonyloctanoate (190)

The general procedure with β -lactam (**184**) (120mg, 0.44mmol.) and sulfone (**189**) followed by flash chromatography (SiO₂, P.E 30-40:ether; 60:40) afforded (2*S*, 5*RS*)-*t*-butyl *N*-(*t*-butoxycarbonyl)-2-amino-4-oxo-5-phenylsulfonyloctanoate (**190**) as a colourless oil (166mg, 80%), (R_f 0.2, P.E 30-40:ether; 60:40), (Found: C, 58.82; H, 7.45; N, 2.69. C₂₃H₃₅NO₇S requires C, 58.82; H, 7.51; N, 2.98%); ν_{\max} (FT IR, CDCl₃ solution, NaCl plates) 2981m, 1718s (C=O), 1499m, 1370s, 1311m, 1154s, 1084m and 707m cm⁻¹; δ_{H} (200MHz; CDCl₃) 0.84-0.91 (3H, m, CH₂CH₃), 1.41 and 1.48 (2 x 9H, 2 x s, CHCO₂C(CH₃)₃ and NHCO₂C(CH₃)₃), 1.39-1.50 (2H, m, CH₂CH₃), 1.80-1.91 (2H, m, CH₂CH₂CH₃), 3.04-3.60 (2H, m, CH₂CHCO₂C(CH₃)₃), 4.02-4.12 (1H, m, CH₂CH₂CH₃), 4.32-4.46 (1H, m, CHCO₂C(CH₃)₃), 5.28-5.41 (1H, m, NH) and 7.51-7.82 (5H, m, SO₂(C₆H₅)); δ_{C} (50MHz; CDCl₃) 13.50 (CH₂CH₃), 19.81 (CH₂CH₃), 27.63 and 28.15 (CHCO₂C(CH₃)₃ and NHCO₂C(CH₃)₃), 28.73 (CH₂CH₂CH₃), 46.51 and 46.85 (CH₂CHCO₂C(CH₃)₃), 49.64 and 49.77 (CHCO₂C(CH₃)₃), 74.73 and 74.83 (CHSO₂(C₆H₅)), 79.83 and 82.36 (CHCO₂C(CH₃)₃ and NHCO₂C(CH₃)₃), 129.30, 129.51 and 134.56 (aromatic CH), 134.56 (aromatic *ipso* C), 155.56 (NHCO₂C(CH₃)₃), 170.03 (CHCO₂C(CH₃)₃) and 201.04 (C(O)CHSO₂(C₆H₅)); m/z (desorption chemical ionisation, NH₃) 487[(MNH₄)⁺, 12%], 470[(MH)⁺, 12], 431[12], 375[55], 370[21], 314[21], 268[100], 127[43], 98[21], 78[20], 70[38] and 57[83].

(2*S*, 5*RS*, 7*S*)-^tButyl *N*-(benzyloxycarbonyl)-2-amino-7-^tbutyldimethylsilyloxy-4-oxo-5-phenylsulfonyloctanoate (242a)

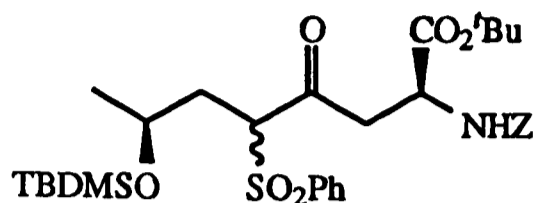

The general procedure with β -lactam (203) (447mg, 1.47mmol.) and sulfone (241) followed by flash chromatography (SiO₂, P.E 30-40:ether; 80:20) afforded (2*S*, 5*RS*, 7*S*)-^tbutyl *N*-(benzyloxycarbonyl)-2-amino-7-^tbutyldimethylsilyloxy-4-oxo-5-phenylsulfonyl octanoate (242) as a colourless oil (774mg, 83%), (R_f 0.3, P.E 30-40:ether; 70:30), (Found: C, 60.67; H, 7.63; N, 1.95. C₃₂H₄₇NO₈SSi requires C, 60.64; H, 7.47; N, 2.21%); ν_{\max} (FT IR, Thin film, NaCl plates) 2956s, 2931s, 2897m, 2858s, 1724s (C=O), 1505s, 1427s, 1472s, 1394s, 1370s, 1324s, 1311m, 1220s, 1155s, 1084m, 1071s, 911s, 839m and 775s cm⁻¹; δ_{H} (200MHz; CDCl₃) -0.03 and -0.02 (6H, 2 x s, Si(CH₃)₂), 0.82 and 0.84 (9H, 2 x s, SiC(CH₃)₃), 0.89 and 1.08 (3H, 2 x d, 2 x *J* 6Hz, CH(OSi(CH₃)₂C(CH₃)₃)CH₃), 1.41 and 1.46 (9H, 2 x s, CHCO₂C(CH₃)₃), 1.87-2.12 (2H, m, CH₂CH(OSi(CH₃)₂C(CH₃)₃)CH₃), 3.13-3.95 (3H, m, CH₂CHCO₂C(CH₃)₃ and CH(OSi(CH₃)₂C(CH₃)₃)), 4.28-4.57 (2H, m, CH₂CHCO₂C(CH₃)₃ and CHSO₂(C₆H₅)), 5.12-5.21 (2H, m, NHCO₂CH₂(C₆H₅)), 5.54-5.66 (1H, m, NH) and 7.29-7.80 (10H, m, SO₂(C₆H₅) and NHCO₂CH₂(C₆H₅)); δ_{C} (50MHz; CDCl₃) -4.97, -4.96 and -3.99 (Si(CH₃)₂), 17.78 (SiC(CH₃)₃), 23.47 and 24.14 (CH(OSi(CH₃)₂C(CH₃)₃)CH₃), 25.66 and 27.67 (CHCO₂C(CH₃)₃ and SiC(CH₃)₃), 35.92 and 36.66 (CH₂CH(OSi(CH₃)₂C(CH₃)₃)CH₃), 46.47 and 46.76 (CH₂CHCO₂C(CH₃)₃), 50.18 (CH₂CHCO₂C(CH₃)₃), 65.50 (CHSO₂(C₆H₅)), 66.89 and 67.01 (NHCO₂CH₂(C₆H₅)), 70.85 and 72.01 (CH(OSi(CH₃)₂C(CH₃)₃), 82.52 (CHCO₂C(CH₃)₃), 128.23, 128.34, 128.70, 129.29, and 134.51 (aromatic CH), 136.51 and 136.60 (2 x aromatic ipso C), 156.18 (NHCO₂CH₂(C₆H₅)), 169.80 (CHCO₂C(CH₃)₃) and 200.51 and 200.70

(C(O)CHSO₂(C₆H₅)); m/z (desorption chemical ionisation, NH₃) 651[(MNH₄)⁺, 25%], 595[10], 400[20], 108[23], 91[100] and 57[28].

(2*S*, 5*RS*, 7*R*)-^tButyl *N*-(benzyloxycarbonyl)-2-amino-7-^tbutyldimethylsilyloxy-4-oxo-5-phenylsulfonyloctanoate (242b)

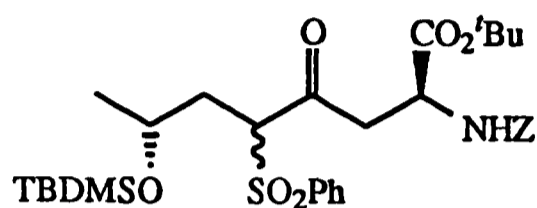

The general procedure with β -lactam (**203**) (489mg, 1.60mmol.) and sulfone (**254**) followed by flash chromatography (SiO₂, P.E 30-40:ether; 80:20) afforded (2*S*, 5*RS*, 7*R*)-^tbutyl *N*-(benzyloxycarbonyl)-2-amino-7-^tbutyldimethylsilyloxy-4-oxo-5-phenylsulfonyloctanoate (**242b**) as a colourless oil (808mg, 80%), (R_f 0.3, P.E 30-40:ether; 70:30); ν_{\max} (FT IR, Thin film, NaCl plates) 3432br m (NH), 2956s, 2931s, 2897m, 1728s (C=O), 1505s, 1449s, 1472s, 1370s, 1324s, 1311m, 1256s, 1155s, 1070s, 911s and 735s cm⁻¹; δ_{H} (200MHz; CDCl₃) -0.08, -0.04 and -0.01 (6H, 3 x s, Si(CH₃)₂), 0.81 and 0.85 (9H, 2 x s, SiC(CH₃)₃), 0.99 and 1.06 (3H, 2 x d, 2 x *J* 6Hz, CH(OSi(CH₃)₂C(CH₃)₃)CH₃), 1.41 and 1.47 (9H, 2 x s, CHCO₂C(CH₃)₃), 1.69-2.19 (2H, m, CH₂CH(OSi(CH₃)₂C(CH₃)₃)CH₃), 3.08-4.11 (3H, m, CH₂CHCO₂C(CH₃)₃ and CH(OSi(CH₃)₂C(CH₃)₃)), 4.28-4.60 (2H, m, CH₂CHCO₂C(CH₃)₃ and CHSO₂(C₆H₅)), 5.08-5.21 (2H, m, NHCO₂CH₂(C₆H₅)), 5.54-5.66 (1H, m, NH) and 7.28-7.82 (10H, m, SO₂(C₆H₅) and NHCO₂CH₂(C₆H₅)); δ_{C} (50MHz; CDCl₃) -5.25, -5.08, -4.87 and -4.21 (Si(CH₃)₂), 17.81 (SiC(CH₃)₃), 23.60 and 23.81 (CH(OSi(CH₃)₂C(CH₃)₃)CH₃), 25.68 and 27.68 (CHCO₂C(CH₃)₃ and SiC(CH₃)₃), 35.64 and 36.40 (CH₂CH(OSi(CH₃)₂C(CH₃)₃)CH₃), 46.14 and 46.95 (CH₂CHCO₂C(CH₃)₃), 50.12 (CH₂CHCO₂C(CH₃)₃), 65.34 (CHSO₂(C₆H₅)), 66.97 (NHCO₂CH₂(C₆H₅)), 71.02 and 71.51 (CH(OSi(CH₃)₂C(CH₃)₃)), 82.65 (CHCO₂C(CH₃)₃), 128.34, 128.71, 129.39, and 134.53 (aromatic CH), 136.51 and 136.67 (2 x aromatic ipso C), 156.20 (NHCO₂CH₂(C₆H₅)), 169.95 (CHCO₂C(CH₃)₃) and 199.97

and 200.99 ($\underline{C}(O)CHSO_2(C_6H_5)$); m/z (desorption chemical ionisation, NH_3) 651[(MNH_4)⁺, 28%], 595[12], 400[17], 108[25], 91[100] and 57[27].

Preparation of Aluminium Amalgam¹¹²

Aluminium foil was cut into strips (0.5cm x 0.5cm) and placed in a Schlenk tube fitted with a filter. After the tube had been flushed with argon a solution of a 2% aqueous solution of mercuric chloride was added. The flask was shaken for fifteen seconds before a greater pressure of argon was applied and the mercuric chloride solution allowed to filter off. The aluminium strips were rinsed with degassed absolute ethanol and then with diethylether and added rapidly to the reaction mixture.

General procedure for the preparation of γ -keto α -amino acids by Al/Hg reduction of β -ketosulfones (179), (185), (198), (204), (190), (242a) and (242b)

To a stirred solution of β -ketosulfone in degassed THF:H₂O 9:1 (20mM solution) was added freshly prepared aluminium amalgam (24g.-atoms of Al/mole of compound). The mixture was stirred at room temperature for five hours and then further aluminium amalgam (24g.-atoms of Al/mole of compound) was added. The reaction mixture was stirred for a further fifteen hours before being filtered through Celite® (ether eluent), dried (MgSO₄), filtered and concentrated *in vacuo*.

(2S)-Benzyl N-(*t*butoxycarbonyl)-2-amino-4-oxopentanoate (159) Method 3

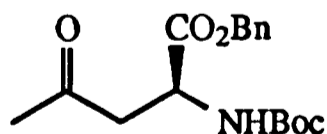

The general procedure with β -ketosulfone (179) (65mg, 0.15mmol.) followed by flash chromatography (SiO₂, P.E. 30-40:ether; 70:30; 50:50; gradient elution) afforded (2S)-benzyl N-(*t*butoxycarbonyl)-2-amino-4-oxopentanoate (159) as a yellow oil (44mg, 80%).

All physical and spectroscopic data were identical with the sample prepared by method 2 above.

(2S)-^tButyl N-(^tbutoxycarbonyl)-2-amino-4-oxopentanoate (186)

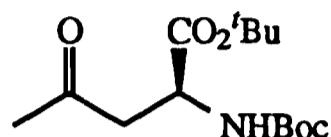

The general procedure with β -ketosulfone (185) (89mg, 0.21mmol.) followed by flash chromatography (SiO₂, P.E. 30-40:ether; 60:40) afforded (2S)-^tbutyl N-(^tbutoxycarbonyl)-2-amino-4-oxopentanoate (186) as a white crystalline solid (54mg, 90%), m.p.72-74°C (from P.E.30-40:ether), (R_f 0.4, P.E 30-40:ether; 60:40), (Found: C, 58.8; H, 9.1; N, 4.7. C₁₄H₂₅NO₅ requires C, 58.52; H, 8.77; N, 4.87%); [α]_D +14.5 (*c* 1.0 in CHCl₃); ν_{\max} (FT IR, KBr disc) 3463m, 2980m, 1733s (C=O), 1720 (C=O), 1497s, 1405m, 1368s, 1338s, 1249m, 1222s, 1158s and 1059 cm⁻¹; δ_{H} (200MHz; CDCl₃) 1.44 (18H, s, NHCO₂C(CH₃)₃ and CHCO₂C(CH₃)₃), 2.19 (3H, s, C(O)CH₃), 2.90 (1H, dd, *J* 5Hz, *J* 17Hz, 1 x CH₂CH), 3.12 (1H, dd, *J* 5Hz, *J* 17Hz, 1 x CH₂CH), 4.35 (1H, ddd, *J* 5Hz, *J* 5Hz, *J* 9Hz, CH₂CH) and 5.45 (1H, d, *J* 9Hz, NH); δ_{C} (50MHz; CDCl₃) 27.69 and 28.15 (CHCO₂C(CH₃)₃ and NHCO₂C(CH₃)₃), 29.78 (C(O)CH₃), 45.46 (CH₂CH), 50.03 (CH₂CH), 79.79 and 82.05 (CHCO₂C(CH₃)₃ and NHCO₂C(CH₃)₃), 155.82 (NHCO₂C(CH₃)₃), 170.58 (CHCO₂C(CH₃)₃) and 206.93 (C(O)CH₃); m/z (chemical ionisation, NH₃) 288 [(MH)⁺, 12%], 232[20], 193[40], 176[39], 132[21], 86[100] and 57[22].

(2S, 7RS)-^tButyl N-(^tbutoxycarbonyl)-2-amino-7-(^tbutyldiphenylsilyloxy)-4-oxooctanoate (199)

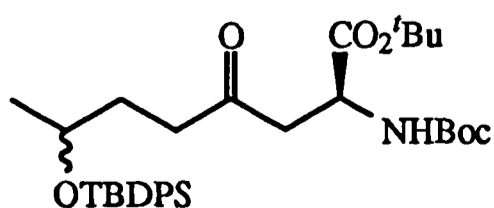

The general procedure with β -ketosulfone (198) (207mg, 0.28mmol.) followed by flash chromatography (SiO₂, P.E. 30-40:ether; 80:20) afforded (2*S*, 7*RS*)-*t*-butyl *N*-(*t*-butoxycarbonyl)-2-amino-7-*t*-butyldiphenylsilyloxy-4-oxooctanoate (199) as a colourless oil (163mg, 95%), (R_f 0.3, P.E 30-40:ether; 80:20); ν_{\max} (FT IR, Thin film, NaCl plates) 3439 br m (NH), 3072m, 2975s, 2933s, 1718s (C=O), 1496s, 1368s, 1156s, 1111s and 704s cm⁻¹; δ_{H} (200MHz; CDCl₃) 1.03-1.05 (9H, 2 x s, SiC(CH₃)₃), 1.27-1.28 (3H, 2 x d, 2 x *J* 6Hz, CHCH₃), 1.43 and 1.45 (2 x 9H, 2 x s, CHCO₂C(CH₃)₃ and NHCO₂C(CH₃)₃), 1.67-1.74 (2H, m, CH₂CH(OSiC(CH₃)₃(C₆H₅)₂)), 2.25-2.58 (2H, m, CH₂CH₂CH), 2.65-3.13 (2H, m, CH₂CHCO₂C(CH₃)₃), 3.80-3.94 (1H, m, CHOSiC(CH₃)₃(C₆H₅)₂), 4.25-4.40 (1H, m, CH₂CHCO₂C(CH₃)₃), 5.22-5.40 (1H, m, NH), 7.30-7.45 and 7.60-7.80 (10H, 2 x m, Si(C₆H₅)₂); δ_{C} (125MHz; CDCl₃) 19.25 (SiC(CH₃)₃), 23.04 and 23.12 (CH(OSiC(CH₃)₃(C₆H₅)₂)CH₃), 27.05, 27.89 and 28.35 (NHCO₂C(CH₃)₃, CHCO₂C(CH₃)₃ and SiC(CH₃)₃), 32.80 (CH₂CH(OSiC(CH₃)₃(C₆H₅)₂)CH₃), 38.50 (CH₂CH₂CH(OSiC(CH₃)₃(C₆H₅)₂)CH₃), 44.49 (CH₂CHCO₂C(CH₃)₃), 50.03 (CH₂CHCO₂C(CH₃)₃), 68.63 (CH(OSiC(CH₃)₃(C₆H₅)₂)), 79.67 and 81.92 (NHCO₂C(CH₃)₃ and CHCO₂C(CH₃)₃), 127.49, 127.62, 129.55, 129.64 and 135.86 (aromatic CH), 134.30 and 134.66 (2 x aromatic *ipso* C), 155.70 (NHCO₂C(CH₃)₃), 170.34 (CHCO₂C(CH₃)₃) and 208.55 (C(O)CH₂CH₂(OSiC(CH₃)₃(C₆H₅)₂)CH₃); *m/z* (chemical ionisation, NH₃) 460 [(MH)⁺, 10%], 528[15], 484[19], 472[29], 353[14], 297[14], 216[100], 198[67], 170[28], 155[29], 126[49], 99[53] and 57[70].

(2*S*)-*t*-Butyl *N*-(benzyloxycarbonyl)-2-amino-4-oxopentanoate (205)

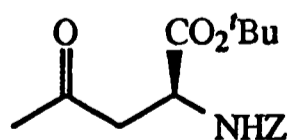

The general procedure with β -ketosulfone (204) (344mg, 0.75mmol.) followed by flash chromatography (SiO₂, P.E. 30-40:ether; 50:50) afforded (2*S*)-*t*-butyl *N*-(benzyloxycarbonyl)-2-amino-4-oxopentanoate (205) as a colourless oil (220mg, 92%), (R_f

0.3, P.E 30-40:ether; 50:50), (Found: C, 63.88; H, 7.56; N, 4.32. $C_{17}H_{23}NO_5$ requires C, 63.57; H, 7.21; N, 4.36%); $[\alpha]_D +20.0$ (*c* 1.0 in $CHCl_3$); ν_{max} (FT IR, $CDCl_3$ solution, NaCl plates) 3345br m (NH), 3065m, 2979m, 1719s (C=O), 1509s, 1456s, 1395s, 1370s, 1256s, 1223s, 1156s, 1055s, 847s, 742s and 699s cm^{-1} ; δ_H (200MHz; $CDCl_3$) 1.43 (9H, s, $CO_2C(CH_3)_3$), 2.15 (3H, s, $C(O)CH_3$), 2.90 (1H, dd, *J* 4Hz, *J* 16Hz, 1 x CH_2CH), 3.14 (1H, dd, *J* 4Hz, *J* 16Hz, 1 x CH_2CH), 4.44 (1H, td *J* 4Hz, *J* 8Hz, CH_2CH), 5.10 (2H, s, $CH_2(C_6H_5)$) 5.73 (1H, d, *J* 8Hz, NH) and 7.34 (5H, s, $NHCO_2CH_2(C_6H_5)$); δ_C (50MHz; $CDCl_3$) 27.70 ($CO_2C(CH_3)_3$), 29.78 ($C(O)CH_3$), 45.33 (CH_2CH), 50.48 (CH_2CH), 66.89 ($CH_2(C_6H_5)$), 82.38 ($CO_2C(CH_3)_3$), 128.22 and 128.67 (aromatic CH), 136.52 (aromatic ipso C), 156.34 ($NHCO_2CH_2(C_6H_5)$), 170.20 ($CO_2C(CH_3)_3$) and 205.10 ($C(O)CH_3$); *m/z* (chemical ionisation, NH_3) 339[(MNH_4)⁺, 8%], 322[(MH)⁺, 112], 283[35], 266[75], 222[14], 176[20], 108[40], 91[100] and 86[33].

(2*S*)-^tButyl *N*-(^tbutoxycarbonyl)-2-amino-4-oxooctanoate (191) Method 1 (Sulfone Route)

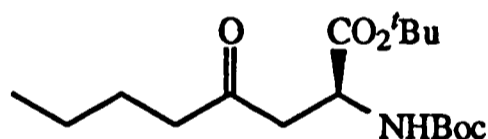

The general procedure with β -ketosulfone (190) (100mg, 0.21mmol.) followed by flash chromatography (SiO_2 , P.E. 30-40:ether; 70:30; 50:50; gradient elution) afforded (2*S*)-^tbutyl *N*-(^tbutoxycarbonyl)-2-amino-4-oxooctanoate (191) as a colourless oil (63mg, 90%), (R_f 0.4, P.E 30-40:ether; 50:50), (Found: C, 62.27; H, 9.58; N, 4.09. $C_{17}H_{31}NO_5$ requires C, 61.98; H, 9.48; N, 4.25%); $[\alpha]_D +20.8$ (*c* 1.0 in $CHCl_3$); ν_{max} (FT IR, Thin film, NaCl plates) 3847m (NH), 3439s, 2977s, 2934s, 2875s, 1719br s (C=O), 1499s, 1393s, 1368s, 1252s and 1155s cm^{-1} ; δ_H (200MHz; $CDCl_3$) 0.91 (3H, t, *J* 7Hz, CH_2CH_3), 1.25-1.55 (4H, m, CH_2CH_3 and $CH_2CH_2CH_3$), 1.45 (18H, s, $CHCO_2C(CH_3)_3$ and $NHCO_2C(CH_3)_3$), 2.42 (2H, t, *J* 7Hz, $CH_2CH_2CH_2CH_3$), 2.87 (1H, dd, *J* 4Hz, *J* 17Hz, 1 x CH_2CH), 3.10 (1H, dd, *J* 4Hz, *J* 17Hz, 1 x CH_2CH), 4.35 (1H, td, *J* 4Hz, *J* 8Hz, CH_2CH) and 5.45 (1H, d, *J* 8Hz, NH); δ_C (50MHz; $CDCl_3$) 13.62 (CH_2CH_3), 22.09

(CH₂CH₂CH₃), 25.67 (CH₂CH₂CH₂CH₃), 27.72 and 28.18 (CHCO₂C(CH₃)₃) and NHCO₂C(CH₃)₃), 42.40 (CH₂CH₂CH₂CH₃), 44.45 (CH₂CHCO₂C(CH₃)₃), 50.06 (CH₂CHCO₂C(CH₃)₃), 79.71 and 82.01 (CHCO₂C(CH₃)₃) and NHCO₂C(CH₃)₃), 155.89 (NHCO₂C(CH₃)₃), 170.68 (CHCO₂C(CH₃)₃) and 209.60 (C(O)CH₂CH₂CH₂CH₃); m/z (chemical ionisation, NH₃) 330 [(MH)⁺, 50%], 274[33], 235[28], 230[31], 218[50], 174[14], 128[100], 85[33] and 57[56].

(2*S*, 7*S*)-^tButyl *N*-(benzyloxycarbonyl)-2-amino-7-^tbutyldimethylsilyloxy-4-oxooctanoate (243a)

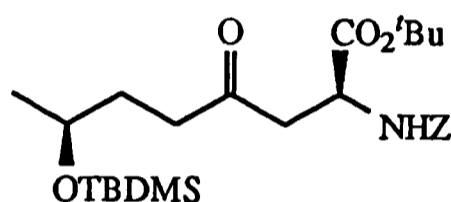

The general procedure with β -ketosulfone (242a) (700mg, 1.1mmol.) followed by flash chromatography (SiO₂, P.E. 30-40:ether; 80:20) afforded (2*S*, 7*S*)-^tbutyl *N*-(benzyloxycarbonyl)-2-amino-7-^tbutyldimethylsilyloxy-4-oxooctanoate (243a) as a colourless oil (485mg, 89%), (R_f 0.2, P.E 30-40:ether; 80:20), m/z (high resolution) Found 494.2938, C₂₆H₄₃NO₆Si+H⁺ requires 494.2938; [α]_D +25.2 (c 1.0 in CHCl₃); ν_{\max} (FT IR, Thin film, NaCl plates) 3358br m (NH), 2956s, 1724s (C=O), 1505s, 1473m, 1457s, 1394m, 1370s, 1340s, 1256s, 1219s, 1157s and 776s cm⁻¹; δ_{H} (200MHz; CDCl₃) 0.02 and 0.04 (6H, 2 x s, Si(CH₃)₂) 0.99 (9H, s, SiC(CH₃)₃), 1.12 (3H, d, *J* 6Hz, CH(OSi(CH₃)₂C(CH₃)₃)CH₃), 1.43 (9H, s, CHCO₂C(CH₃)₃), 1.55-1.80 (2H, m, CH₂CH(OSi(CH₃)₂C(CH₃)₃)CH₃), 2.38-2.58 (2H, m, CH₂CH₂CH(OSi(CH₃)₂C(CH₃)₃)CH₃), 2.92 (1H, dd, *J* 4.5Hz, *J* 17.5Hz, 1 x CH₂CHCO₂C(CH₃)₃), 3.14 (1H, dd, *J* 4.5Hz, *J* 17.5Hz, 1 x CH₂CHCO₂C(CH₃)₃), 3.74-3.90 (1H, m, CH(OSi(CH₃)₂C(CH₃)₃)), 4.44 (1H, td, *J* 4.5Hz, *J* 8.5Hz, CH₂CHCO₂C(CH₃)₃), 5.11 (2H, s, NHCO₂CH₂(C₆H₅)), 5.72 (1H, d, *J* 8.5Hz, NH) and 7.35 (5H, s, NHCO₂CH₂(C₆H₅)); δ_{C} (50MHz; CDCl₃) -4.95 and -4.58 (Si(CH₃)₂), 17.89

(SiC(CH₃)₃), 23.52 (CH(OSi(CH₃)₂C(CH₃)₃)CH₃), 25.74 and 27.71 (CHCO₂C(CH₃)₃) and SiC(CH₃)₃), 32.80 (CH₂CH(OSi(CH₃)₂C(CH₃)₃)CH₃), 38.63 (CH₂CH₂CH(OSi(CH₃)₂C(CH₃)₃)CH₃), 44.37 (CH₂CHCO₂C(CH₃)₃), 50.50 (CH₂CHCO₂C(CH₃)₃), 66.87 (NHCO₂CH₂(C₆H₅), 67.42 (CH(OSi(CH₃)₂C(CH₃)₃)), 82.25 (CHCO₂C(CH₃)₃), 128.20 and 128.67 (aromatic CH), 136.56 (aromatic *ipso* C), 156.36 (NHCO₂CH₂(C₆H₅)), 170.28 (CHCO₂C(CH₃)₃) and 209.10 (C(O)CH₂CH₂CH(OSi(CH₃)₂C(CH₃)₃)CH₃); m/z (chemical ionisation, NH₃) 494[(MH)⁺, 27%], 438[8], 330[40], 306[7], 272[26], 229[10], 198[38], 108[30], 91[100], 74[25] and 57[13].

(2*S*, 7*R*)-*t*-Butyl *N*-(benzyloxycarbonyl)-2-amino-7-*t*-butyldimethylsilyloxy-4-oxooctanoate (243b)

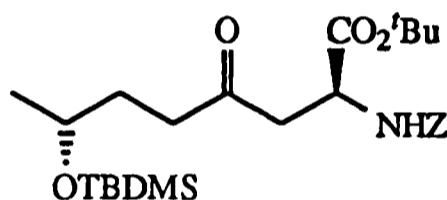

The general procedure with β -ketosulfone (242b) (800mg, 1.26mmol.), followed by flash chromatography (SiO₂, P.E. 30-40:ether; 80:20) afforded (2*S*, 7*R*)-*t*-butyl *N*-(benzyloxycarbonyl)-2-amino-7-*t*-butyldimethylsilyloxy-4-oxooctanoate (243b) as a colourless oil (592mg, 95%), (R_f 0.2, P.E 30-40:ether; 80:20); [α]_D +3.2 (*c* 1.3 in CHCl₃); ν_{\max} (FT IR, Thin film, NaCl plates) 3431br m (NH), 2957s, 2930m, 1719s (C=O), 1505s, 1370s, 1355m, 1219s, 1157s, 1068s, 837m and 776s cm⁻¹; δ_{H} (200MHz; CDCl₃) 0.01 and 0.03 (6H, 2 x s, Si(CH₃)₂) 0.87 (9H, s, SiC(CH₃)₃), 1.10 (3H, d, *J* 6Hz, CH(OSi(CH₃)₂C(CH₃)₃)CH₃), 1.41 (9H, s, CHCO₂C(CH₃)₃), 1.51-1.76 (2H, m, CH₂CH(OSi(CH₃)₂C(CH₃)₃)CH₃), 2.31-2.60 (2H, m, CH₂CH₂CH(OSi(CH₃)₂C(CH₃)₃)), 2.78 (1H, dd, *J* 4Hz, *J* 18Hz, 1 x CH₂CHCO₂C(CH₃)₃), 3.13 (1H, dd, *J* 4Hz, *J* 18Hz, 1 x CH₂CHCO₂C(CH₃)₃), 3.71-3.89 (1H, m, CH(OSi(CH₃)₂C(CH₃)₃)), 4.43 (1H, td, *J* 4Hz, *J* 8.5Hz, CH₂CHCO₂C(CH₃)₃), 5.09 (2H, s, NHCO₂CH₂(C₆H₅)), 5.76 (1H, d, *J* 8.5Hz,

NH) and 7.33 (5H, s, $\text{NHCO}_2\text{CH}_2(\text{C}_6\text{H}_5)$); δ_{C} (50MHz; CDCl_3) -5.02 and -4.61 ($\text{Si}(\text{CH}_3)_2$), 17.88 ($\text{Si}(\text{CH}_3)_3$), 23.57 ($\text{CH}(\text{OSi}(\text{CH}_3)_2\text{C}(\text{CH}_3)_3)\text{CH}_3$), 25.72 and 27.70 ($\text{CHCO}_2\text{C}(\text{CH}_3)_3$ and $\text{Si}(\text{CH}_3)_3$), 32.80 ($\text{CH}_2\text{CH}(\text{OSi}(\text{CH}_3)_2\text{C}(\text{CH}_3)_3)\text{CH}_3$), 38.60 ($\text{CH}_2\text{CH}_2\text{CH}(\text{OSi}(\text{CH}_3)_2\text{C}(\text{CH}_3)_3)\text{CH}_3$), 44.34 ($\text{CH}_2\text{CHCO}_2\text{C}(\text{CH}_3)_3$), 50.49 ($\text{CH}_2\text{CHCO}_2\text{C}(\text{CH}_3)_3$), 66.83 ($\text{NHCO}_2\text{CH}_2(\text{C}_6\text{H}_5)$), 67.31 ($\text{CH}(\text{OSi}(\text{CH}_3)_2\text{C}(\text{CH}_3)_3$)), 82.20 ($\text{CHCO}_2\text{C}(\text{CH}_3)_3$), 128.19 and 128.65 (aromatic CH), 136.56 (aromatic *ipso* C), 156.36 ($\text{NHCO}_2\text{CH}_2(\text{C}_6\text{H}_5)$), 170.27 ($\text{CHCO}_2\text{C}(\text{CH}_3)_3$) and 209.08 ($\text{C}(\text{O})\text{CH}_2\text{CH}_2\text{CH}(\text{OSi}(\text{CH}_3)_2\text{C}(\text{CH}_3)_3)\text{CH}_3$); m/z (chemical ionisation, NH_3) 494[(MH)⁺, 29%], 438[10], 330[38], 306[5], 272[27], 229[12], 198[39], 108[33], 91[100], 74[24] and 57[10].

(2S)-^tButyl N-(^tbutoxycarbonyl)-2-amino-4-oxooctanoate (Method 2: Cuprate Route) (191)
and (2S)-^tbutyl N-(^tbutoxycarbonyl)-2-amino-4-ⁿbutylcarboxybutanoate (221)

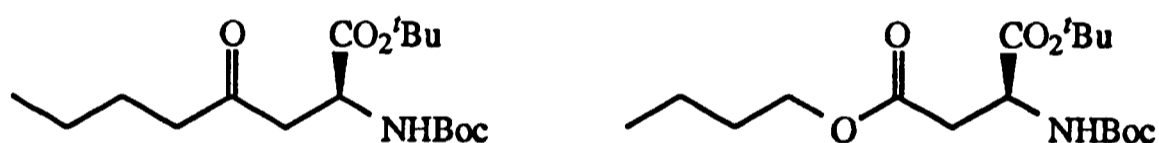

To a stirred suspension of CuCN (122mg, 1.36mmol., 1.3 eq.) in anhydrous THF (2ml) at -78°C , under an inert atmosphere of argon, was added ⁿbutyllithium (1.82ml of a 1.50M solution in hexanes, 2.72mmol., 2.6 eq.). The resulting mixture was allowed to warm to 0°C whereupon a clear tan solution was observed. The mixture was then re-cooled to -78°C and (4S)-^tbutyl N-(^tbutoxycarbonyl)azetidin-2-one-4-carboxylate (184) (285mg, 1.05mmol.) was added as a solution in anhydrous THF (5ml). The reaction mixture was then stirred at -60°C for one hour before being quenched by the addition of a 9:1 saturated $\text{NH}_4\text{Cl}:\text{NH}_4\text{OH}$ solution (5ml). The organic layer was separated, diluted with ether (50ml), washed with 9:1 saturated $\text{NH}_4\text{Cl}:\text{NH}_4\text{OH}$ (3 x 20ml), dried (MgSO_4), filtered and concentrated *in vacuo* to yield a brown oil. Flash chromatography (SiO_2 , P.E. 30-40:ether; 70:30; 50:50; gradient elution) afforded (2S)-^tbutyl N-(^tbutoxycarbonyl)-2-amino-4-oxooctanoate (191) as a colourless oil (145mg, 42%). ^1H n.m.r., t.l.c. analysis and I.R.

were identical to (191) prepared by the desulfonylation route above; $[\alpha]_D +19.4$ (c 1 in CHCl_3) and (2*S*)-*t*-butyl *N*-(*t*-butoxycarbonyl)-2-amino-4-*n*-butylcarboxybutanoate (221) as a yellow oil which solidified on standing (19mg, 5%), m.p. 30-32°C (P.E.30-40:ether), (R_f 0.6, P.E 30-40:ether; 50:50); ν_{max} (FT IR, KBr disc) 2977m, 2935m, 1729br s (C=O), 1499s, 1393m, 1368s, 1251s and 1156s cm^{-1} ; δ_H (200MHz; CDCl_3) 0.95 (3H, t, CH_2CH_3), 1.25-1.70 (4H, m, CH_2CH_3 and $\text{CH}_2\text{CH}_2\text{CH}_3$) 1.46 and 1.47 (2 x 9H, 2 x s, $\text{CHCO}_2\text{C}(\text{CH}_3)_3$ and $\text{NHCO}_2\text{C}(\text{CH}_3)_3$), 2.75 (2H, dd, J 5Hz, J 16.5Hz, 1 x CH_2CH), 2.94 (1H, dd, J 4.5Hz, J 16.5Hz, 1 x CH_2CH), 4.10 (1H, dt, J 1.5Hz, J 6.5Hz, OCH_2), 4.45 (1H, ddd, J 4.5Hz, J 5Hz, J 8Hz, CH_2CH) and 5.45 (1H, d, J 8Hz, NH); m/z (chemical ionisation, NH_3) 346 [(MH)⁺, 35%], 290[30], 234[33], 190[20], 144[100] and 57[40].

(2*S*)-Benzyl *N*-(*t*-butoxycarbonyl)-2-amino-4-oxooctanoate (222) and (2*S*)-Benzyl *N*-(*t*-butoxy carbonyl)-2-amino-4-*n*-butylcarboxybutanoate (223)

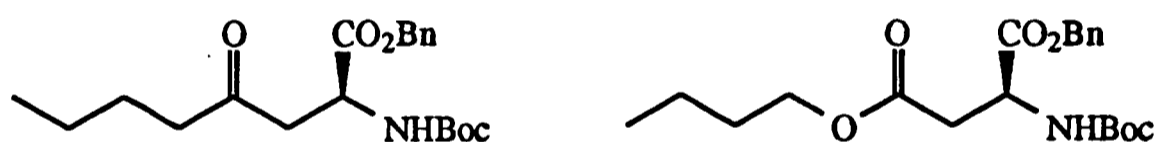

The above procedure with β -lactam (144) (314mg, 1.03mmol.) followed by flash chromatography (SiO_2 , P.E. 30-40:ether; 90:10; 70:30; gradient elution) afforded (2*S*)-benzyl *N*-(*t*-butoxycarbonyl)-2-amino-4-oxooctanoate (222) as a yellow oil (150mg, 40%), (R_f 0.3, P.E 30-40:ether; 80:20), (Found: C, 66.13; H, 8.07; N, 3.56. $\text{C}_{20}\text{H}_{29}\text{NO}_5$ requires C, 66.09; H, 8.04; N, 3.85%); $[\alpha]_D -8.3$ (c 0.5 in MeOH); ν_{max} (FT IR, Thin film, NaCl plates) 3035br m (NH), 2961m, 1742m (C=O), 1718s (C=O), 1499s, 1368s, 1251s, 1167s, 752s and 699m cm^{-1} ; δ_H (200MHz; CDCl_3) 0.88 (3H, t, J 7Hz, CH_2CH_3), 1.18-1.63 (4H, m, $\text{CH}_2\text{CH}_2\text{CH}_3$), 1.43 (9H, s, $\text{NHCO}_2\text{C}(\text{CH}_3)_3$), 2.34 (2H, t, J 7Hz, $\text{CH}_2\text{CH}_2\text{CH}_2\text{CH}_3$), 2.90 (1H, dd, J 5Hz, J 17Hz, 1 x CH_2CH), 3.15 (1H, dd, J 5Hz, J 17Hz, 1 x CH_2CH), 4.55 (1H, td, J 5Hz, J 8Hz, CH_2CH), 5.14 and 5.18 (2H, ABq, J 14Hz, $\text{CHCO}_2\text{CH}_2(\text{C}_6\text{H}_5)$), 5.21 (1H, d, J 8Hz, NH) and 7.34 (5H, s, $\text{CHCO}_2\text{CH}_2(\text{C}_6\text{H}_5)$); δ_C

(50MHz; CDCl₃) 13.78 (CH₂CH₃), 22.16 (CH₂CH₃), 25.64 (CH₂CH₂CH₃), 28.26 (NHCO₂C(CH₃)₃), 42.46 (CH₂CH₂CH₂CH₃), 44.31 (CH₂CH), 49.66 (CH₂CH), 67.33 (CHCO₂CH₂(C₆H₅)), 80.04 (NHCO₂CC(CH₃)₃), 127.40, 128.53 and 128.74 (aromatic CH), 135.63 (aromatic *ipso* C), 155.90 (NHCO₂CC(CH₃)₃), 171.66 (CHCO₂CH₂(C₆H₅)) and 209.57 (CC(O)CH₂CH₂CH₂CH₃); m/z (chemical ionisation, NH₃) 364 [(MH)⁺, 7%], 325[11], 314[10], 308[47], 264[72], 228[11], 178[16], 172[10], 158[26], 128[92], 108[33], 91[100], 85[24] and 57[19] and (2*S*)-benzyl *N*-(*t*-butoxycarbonyl)-2-amino-4-*n*-butylcarboxybutanoate (223) as a white crystalline solid (23mg, 6%), m.p. 60-63°C, (R_f 0.8, P.E 30-40:ether; 50:50); ν_{max} (FT IR, Thin film, NaCl plates) 2981m, 1733s (C=O), 1710s (C=O), 1499s, 1456m, 1369m and 1167s cm⁻¹; δ_H (200MHz; CDCl₃) 0.92 (3H, t, CH₂CH₃), 1.20-1.68 (4H, m, CH₂CH₃ and CH₂CH₂CH₃), 1.44 (9H, s, NHCO₂C(CH₃)₃), 2.82 (1H, dd, *J* 5Hz, *J* 17Hz, CH₂CH), 3.01 (1H, dd, *J* 4.5Hz, *J* 17Hz, CH₂CH), 4.05 (1H, t, *J* 6.5Hz, OCH₂), 4.62 (1H, ddd, *J* 4.5Hz, *J* 5Hz, *J* 8Hz, CH₂CH), 5.15 and 5.22 (2H, ABq, *J* 10Hz, CH₂(C₆H₅)) and 7.36 (5H, s, CH₂(C₆H₅)); δ_C (50MHz; CDCl₃) 13.66 (CH₂CH₃), 22.06 (CH₂CH₃), 25.53 (CH₂CH₂CH₃), 28.15 (NHCO₂C(CH₃)₃), 49.57 (CH₂CH₂CH₂CH₃), 44.31 (CH₂CH), 49.66 (CH₂CH), 67.33 (CHCO₂CH₂(C₆H₅)), 79.97 (NHCO₂CC(CH₃)₃), 128.34, 128.49 and 128.70 (aromatic CH), 135.61 (aromatic *ipso* C), 156.70 (NHCO₂CC(CH₃)₃), 171.63 (CHCO₂CH₂(C₆H₅)) and (CO₂CH₂CH₂CH₂CH₃); m/z (chemical ionisation, NH₃) 431[MNH₄⁺, 55], 414[MH⁺, 100].

(2*S*)-*t*-Butyl *N*-(*t*-butoxycarbonyl)-2-amino-5-diethylphosphono-4-oxopentanoate (213)

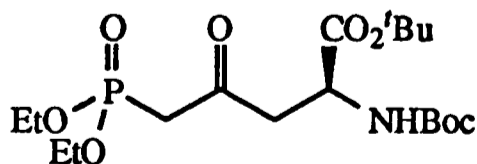

To a stirred solution of diethyl methylphosphonate (168mg, 1.1mmol., 2 eq.) in anhydrous THF (2ml) at -78°C, under an inert atmosphere of argon, was added *n*-butyllithium (691μl of a 1.6M solution in hexanes, 1.1mmol., 2eq.). After stirring at -78°C for ten

minutes, the mixture was warmed to 0°C and stirred at 0°C for ten minutes, before being re-cooled to -78°C, whereupon (4*S*)-^tbutyl *N*-(^tbutoxycarbonyl)azetidin-2-one-4-carboxylate (184) (150mg, 0.55mmol.) was added as a solution in anhydrous THF (5ml). The reaction mixture was then stirred for a further thirty minutes at -78°C before being quenched by the addition of saturated aqueous NH₄Cl (5ml) and diluted with dichloromethane (50ml). The organic layer was separated and washed with saturated aqueous NH₄Cl (2 x 10ml) and saturated aqueous brine (10ml), dried (MgSO₄), filtered and concentrated *in vacuo* to yield a yellow oil. Flash chromatography (SiO₂, P.E. 40-60:ethylacetate; 10:90) afforded (2*S*)-^tbutyl *N*-(^tbutoxyoxycarbonyl)-2-amino-5-diethylphosphono-4-oxopentanoate (213) as a colourless oil (202mg, 87%), (R_f 0.2, P.E 40-60:ethylacetate; 10:90), (Found: C, 50.7; H, 8.3; N, 3.5. C₁₈H₃₄NO₈P requires C, 51.06; H, 8.09; N, 3.31%); [α]_D +16.2 (*c* 0.5 in CHCl₃); ν_{max} (FT IR, Thin film, NaCl plates) 3303m (NH), 2978s, 2933s, 1722br s (C=O), 1502s, 1456s, 1395s, 1367s, 1252s, 1156s, 1028s, 971s, 851s and 799s cm⁻¹; δ_H (200MHz; CDCl₃) 1.34 (6H, t, *J* 6.5Hz, 2 x OCH₂CH₃), 1.43 and 1.45 (2 x 9H, 2 x s, CHCO₂C(CH₃)₃ and NHCO₂C(CH₃)₃), 3.08 (2H, d, *J* 21.5Hz, CH₂P(O)(OEt)₂), 3.09 (1H, dd, *J* 5Hz, *J* 17.5Hz, 1 x CH₂CH), 3.27 (1H, dd, *J* 5Hz, *J* 17.5Hz, 1 x CH₂CH), 4.02-4.22 (4H, m, 2 x OCH₂CH₃), 4.23-4.39 (1H, m, CH₂CH) and 5.49 (1H, d, *J* 8Hz, NH); δ_C (50MHz; CDCl₃) 16.06 and 16.20 (OCH₂CH₃), 27.93 and 28.43 (CHCO₂C(CH₃)₃ and NHCO₂C(CH₃)₃), 41.07, 43.62 (d, *J* C,P 128Hz, CH₂P(O)(OEt)₂), 45.95 (CH₂CH), 49.91 (CH₂CH), 62.59 (OCH₂CH₃), 79.77 and 82.22 (CHCO₂C(CH₃)₃ and NHCO₂C(CH₃)₃), 155.77 (NHCO₂C(CH₃)₃), 170.36 (CHCO₂C(CH₃)₃) and 200.35 (C(O)CH₂P(O)(OEt)₂); *m/z* (FAB, +ve Na), 446[(MNa)⁺, 100%], 424[(MH)⁺, 11], 324[14], 268[74], 251[50] and 222[42].

(2*S*)-^tButyl *N*-(benzyloxycarbonyl)-2-amino-5-diethylphosphono-4-oxopentanoate (214)

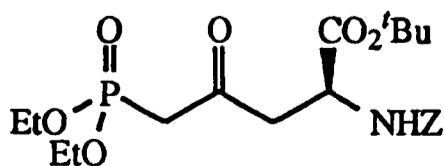

The above procedure with β -lactam (203) (60mg, 0.2mmol.) followed by flash chromatography (SiO₂, P.E. 40-60:ethylacetate; 10:90) afforded (2*S*)-*t*-butyl *N*-(benzyloxycarbonyl)-2-amino-5-diethylphosphono-4-oxopentanoate (214) as a colourless oil (86mg, 94%), (R_f 0.2, P.E 40-60:ethylacetate; 10:90); [α]_D +12.0 (c 1.0 in CHCl₃); ν_{\max} (FT IR, Thin film, NaCl plates) 3281br m, 2987s, 2935s, 1721br s (C=O), 1510m, 1455m, 1396s, 1371s, 1343s, 1254s, 1163s, 1092s, 973s, 849m, 752m and 701s cm⁻¹; δ_{H} (200MHz; CDCl₃) 1.31 (6H, t, *J* 7Hz, 2 x OCH₂CH₃), 1.43 (9H, s, CHCO₂C(CH₃)₃), 3.06 (2H, d, *J* 23Hz, CH₂P(O)(OEt)₂), 3.12 (1H, dd, *J* 4Hz, *J* 20Hz, 1 x CH₂CH), 3.22 (1H, dd, *J* 4.5Hz, *J* 20Hz, 1 x CH₂CH), 4.03-4.20 (4H, m, 2 x OCH₂CH₃), 4.39-4.50 (1H, m, CH₂CH), 5.10 (2H, s, CH₂(C₆H₅)), 5.71 (1H, d, *J* 8Hz, NH) and 7.34 (5H, s, CH₂(C₆H₅)); δ_{C} (50MHz; CDCl₃) 16.06 and 16.18 (OCH₂CH₃), 27.66 (CHCO₂C(CH₃)₃), 42.40 (d, *J* C,P 127.5Hz, CH₂P(O)(OEt)₂), 45.78 (CH₂CH), 50.36 (CH₂CH), 62.60 and 62.71 (OCH₂CH₃), 66.88 (CH₂(C₆H₅)), 82.48 (CHCO₂C(CH₃)₃), 128.23 and 128.67 (aromatic CH), 136.50 (aromatic *ipso* C), 156.29 (NHCO₂CH₂(C₆H₅)), 169.94 (CHCO₂C(CH₃)₃) and 200.18 (C(O)CH₂P(O)(OEt)₂); *m/z* (FAB, +ve Na), 480[(MNa)⁺, 94%], 458[(MH)⁺, 80], 424[32], 402[100], 195[30] and 176[84].

(2*S*)-4-oxo-5-phosphonorvaline (220)^{52,53}

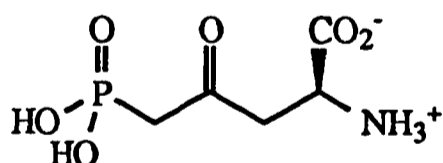

To a stirred solution of (2*S*)-*t*-butyl *N*-(*t*-butoxyoxycarbonyl) 2-amino-5-diethylphosphono-4-oxopentanoate (213) (50mg, 0.12mmol.) in acetonitrile:dichloromethane 50:50 (2ml) was added TMSI (135 μ l, 0.94mmol.). The reaction mixture was stirred at room temperature for eighteen hours then concentrated *in vacuo*. To the residue was added methanol (5ml) and the mixture was stirred at room temperature for one hour then concentrated *in vacuo*. The resulting brown residue was partitioned between ether (20ml) and water (50ml). The aqueous layer was separated and washed with ether (3 x 20ml)

then concentrated *in vacuo* to afford a yellow oil which was purified by ion exchange on Dowex 50W-X8(H) resin 100-200 mesh eluting with 2M NH₄OH to afford (2*S*)-4-oxo-5-phosphonorvaline (220) as a white solid (20mg, 80%), m.p. 110-112°C (authentic sample of enantiomer m.p. 113-115°C¹²⁹); [α]_D -5.4 (c 0.25 in H₂O) (authentic sample of the enantiomer [α]_D +6.0 (c 0.25 in H₂O)¹²⁹); ν_{max} (FT IR, KBr disc) 3427br s (OH), 3143m, 2931s, 1708s (C=O), 1651m, 1634m, 1623m, 1144s and 1060s cm⁻¹; δ_H (200MHz; D₂O) 3.15 (2H, d, *J*_{HP} 21.5Hz, CH₂P(O)(OH)₂), 3.43-3.46 (2H, m, CH₂CH) and 4.32 (1H, t, *J* 5.5Hz, CH₂CH); δ_C (125MHz; D₂O) 45.51 (CH₂CH), 47.74 (d, *J*_{C,P} 114Hz, CH₂P(O)(OH)₂), 51.53 (CH₂CH), 174.48 (CHC(O)₂) and 207.57 (C(O)CH₂P(O)(OH)₂); m/z (negative ion electrospray) 210[(M-H)⁻], 100%].

(2*S*)-^tButyl-2-amino-4-oxopentanoate (208)

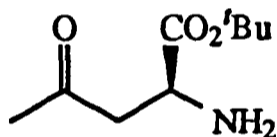

To a stirred suspension of 5% Pd/CaCO₃ (cat.) in ethylacetate (0.5ml) was added (2*S*)-^tbutyl *N*-(benzyloxycarbonyl)-2-amino-4-oxopentanoate (205) (30mg, 0.93mmol.) as a solution in ethylacetate (2ml). The resulting mixture was stirred under an atmosphere of H₂ for one hour before being filtered through a plug of Celite[®] and concentrated *in vacuo* to afford (2*S*)-^tbutyl-2-amino-4-oxopentanoate (208) as a pale yellow oil (17mg, quant.); δ_H (200MHz; CDCl₃) 1.47 (9H, s, CO₂C(CH₃)₃), 2.20 (3H, s, C(O)CH₃), 2.72-2.98 (2H, m, CH₂CH) and 3.69-3.73 (1H, m, CH₂CH).

(2*S*)-^tButyl-2-amino-5-diethylphosphono-4-oxopentanoate (217)

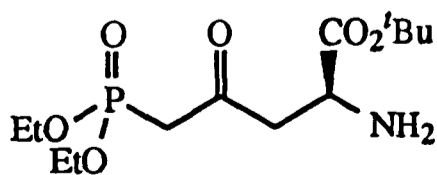

The above procedure with (2*S*)-*t*-butyl *N*-(benzyloxycarbonyl)-2-amino-5-diethylphosphono-4-oxopentanoate (214) (40mg, 0.09mmol.) afforded (2*S*)-*t*-butyl-2-amino-5-diethylphosphono-4-oxopentanoate (217) as a pale yellow oil (28mg, quant.); δ_{H} (200MHz; CDCl₃) 1.34 (6H, t, *J* 7Hz, 2 x OCH₂CH₃), 1.45 (9H, s, CHCO₂C(CH₃)₃), 3.10-3.52 (4H, m, CH₂CH and CH₂P(O)(OEt)₂) and 4.05-4.38 (5H, m, 2 x OCH₂CH₃ and CH₂CH).

(2*S*)-Benzyl-2-amino-4-oxooctanoate (225)

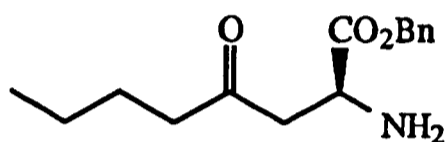

To (2*S*)-benzyl *N*-(*t*-butoxycarbonyl)-2-amino 4-oxooctanoate (222) (15mg, 0.04mmol.) was added trifluoroacetic acid and the mixture was stirred at room temperature for fifteen minutes before being concentrated *in vacuo*. The residue was taken up in ethylacetate (50ml)/saturated aqueous NaHCO₃ (20ml). The organics were separated and the aqueous layer washed with ethylacetate (2 x 50ml). The organics were combined, dried (MgSO₄), filtered and concentrated *in vacuo* to afford (2*S*)-benzyl-2-amino-4-oxooctanoate (225) as a yellow oil (11mg, quant.); δ_{H} (200MHz; CDCl₃) 0.90 (3H, t, *J* 7Hz, CH₃), 1.20-1.40 (2H, m, CH₂CH₃), 1.45-1.61 (2H, m, CH₂CH₂CH₃), 2.25-2.40 (2H, m, CH₂CH₂CH₂CH₃), 3.41 (2H, m, CH₂CH), 3.75-3.94 (1H, m, CH₂CH), 5.10-5.18 (2H, m, CHCO₂CH₂(C₆H₅)) and 7.33-7.37 (5H, m, CH₂(C₆H₅)).

General procedure for the preparation of Mosher's acid derivatives (211), (212), (218), (219), (226) and (227)

To a stirred solution of amine in anhydrous dichloromethane (*ca.* 1ml per 0.05mmol. of amine), under an inert atmosphere of argon, was added (*R*) or (*S*)-Mosher's acid chloride (1.2 eq.) as a solution in anhydrous dichloromethane (*ca.* 0.5ml per 0.05mmol. of amine) followed by DMAP (1.2 eq.). The reaction mixture was stirred at room temperature for

twenty four hours before being concentrated *in vacuo*. ^1H n.m.r. of the residue confirmed that the amine had been completely consumed. The residue was taken up in ether and washed with 1M HCl, saturated aqueous Na_2CO_3 and saturated aqueous brine, dried (MgSO_4), filtered and concentrated *in vacuo* to afford the Mosher's acid derivative.

Mosher's acid derivative (211)

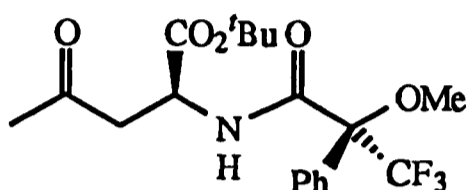

The general procedure with (2*S*)-*t*-butyl-2-amino-4-oxopentanoate (**208**) (21mg, 0.11mmol.) and (*R*)-Mosher's acid chloride afforded the (*S*, *S*)-Mosher's acid derivative (**211**) (48mg crude mass) as a yellow oil; δ_{H} (200MHz; CDCl_3) 1.45 (9H, s, $\text{CHCO}_2\text{C}(\text{CH}_3)_3$), 2.08 (3H, s, $\text{C}(\text{O})\text{CH}_3$), 2.91 (1H, dd, J 5Hz, J 17Hz, 1 x CH_2CH), 3.15 (1H, dd, J 5Hz, J 17Hz, 1 x CH_2CH), 3.53 (3H, d, J 2Hz, OCH_3), 4.69 (1H, td, J 5Hz, J 8Hz, CH_2CH) and 7.32-7.60 (6H, m, C_6H_5 and NH); δ_{F} (235MHz; CDCl_3) -70.54 (s, CF_3).

Mosher's acid derivative (212)

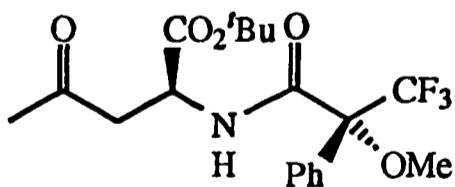

The general procedure with (2*S*)-*t*-butyl-2-amino-4-oxopentanoate (**208**) (20mg, 0.11mmol.) and (*S*)-Mosher's acid chloride afforded the (*S*, *R*)-Mosher's acid derivative (**212**) (47mg crude mass) as a yellow oil; δ_{H} (200MHz; CDCl_3) 1.45 (9H, s, $\text{CHCO}_2\text{C}(\text{CH}_3)_3$), 2.19 (3H, s, $\text{C}(\text{O})\text{CH}_3$), 2.98 (1H, dd, J 5Hz, J 18Hz, 1 x CH_2CH), 3.22 (1H, dd, J 5Hz, J 18Hz, 1 x CH_2CH), 3.35 (3H, s, OCH_3), 4.71 (1H, td, J 5Hz, J

8Hz, CH₂CH), 7.32-7.68 (5H, m, C₆H₅) and 7.88 (1H, d, *J* 8Hz, NH); δ_F (235MHz; CDCl₃) -71.07 (s, CF₃).

Mosher's derivative (218)

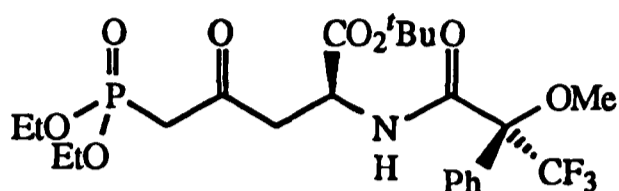

The general procedure with (2*S*)-*t*-butyl-2-amino-5-diethylphosphono-4-oxopentanoate (217) (23mg, 0.07mmol.) and (*R*)-Mosher's acid chloride afforded the (*S*, *S*)-Mosher's acid derivative (218) (50mg crude mass) as a yellow oil; δ_H (500MHz; CDCl₃) 1.29 (6H, dt, *J* 3.5Hz, *J* 7Hz, 2 x OCH₂CH₃), 1.45 (9H, s, CHCO₂C(CH₃)₃), 2.97 (1H, dd, *J* 11.5Hz, *J* 13.5Hz, 1 x CH₂P(O)(OEt)₂), 2.99 (1H, dd, *J* 11.5Hz, *J* 13.5Hz, 1 x CH₂P(O)(OEt)₂), 3.11 (1H, dd, *J* 4Hz, *J* 18.5Hz, 1 x CH₂CH), 3.32 (1H, dd, *J* 5Hz, *J* 18.5Hz, 1 x CH₂CH), 3.50 (3H, d, *J* 1.5Hz, OCH₃), 4.04-4.11 (4H, m, 2 x OCH₂CH₃), 4.71 (1H, ddd, *J* 4Hz, *J* 5Hz, *J* 8Hz, CH₂CH), 7.36-7.53 (5H, m, C₆H₅) and 7.56 (1H, d, *J* 8Hz, NH); δ_F (235MHz; CDCl₃) -70.58 (s, CF₃).

Mosher's derivative (219)

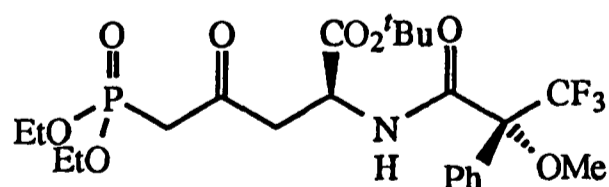

The general procedure with (2*S*)-*t*-butyl 2-amino-5-diethylphosphono-4-oxopentanoate (217) (22mg, 0.07mmol.) and (*S*)-Mosher's acid chloride afforded the (*S*, *R*)-Mosher' acid derivative (219) (53mg crude mass) as a yellow oil; δ_H (500MHz; CDCl₃) 1.34 (6H, t, *J* 7Hz, 2 x OCH₂CH₃), 1.43 (9H, s, CHCO₂C(CH₃)₃), 3.11 (2H, d, *J* 22Hz, 1 x CH₂P(O)(OEt)₂), 3.20 (1H, dd, *J* 4Hz, *J* 18.5Hz, 1 x CH₂CH), 3.35 (1H, dd, *J* 4.5Hz,

J 18.5Hz, 1 x CH_2CH), 3.35 (3H, d, J 1Hz, OCH_3), 4.03-4.12 (4H, m, 2 x OCH_2CH_3), 4.71 (1H, ddd, J 4Hz, J 4.5Hz, J 8Hz, CH_2CH), 7.39-7.52 (5H, m, C_6H_5) and 7.56 (1H, d, J 8Hz, NH); δ_{F} (235MHz; CDCl_3) -72.17 (s, CF_3).

Mosher's acid derivative (226)

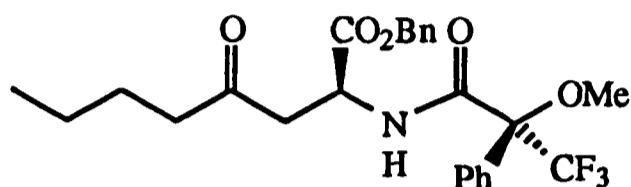

The general procedure with (2*S*)-benzyl-2-amino-4-oxooctanoate (**225**) (22mg, 0.08mmol.) and (*R*)-Mosher's acid chloride afforded the (*S,S*) Mosher's acid derivative (**226**) (51mg crude mass) as a yellow oil; δ_{H} (200MHz; CDCl_3) 0.92 (3H, t, J 7Hz, CH_2CH_3), 1.15-1.50 (4H, m, $\text{CH}_2\text{CH}_2\text{CH}_2\text{CH}_3$), 2.25 (2H, t, J 7Hz, $\text{CH}_2\text{CH}_2\text{CH}_2\text{CH}_3$), 2.90 (2H, dd, J 4Hz, J 17Hz, 1 x CH_2CH), 3.20 (2H, dd, J 4Hz, J 17Hz, 1 x CH_2CH), 3.48 (3H, s, OCH_3), 4.34 (1H, ddd, J 4Hz, J 4Hz, J 8Hz, CH_2CH), 5.12 and 5.23 (2H, ABq, J_{AB} 14Hz, $\text{CH}_2(\text{C}_6\text{H}_5)$), 7.20-7.60 (10H, m, 2 x (C_6H_5)) and 8.22 (1H, d, J 8Hz, NH); δ_{F} (235MHz; CDCl_3) -70.57 (s, CF_3).

Mosher's acid derivative (227)

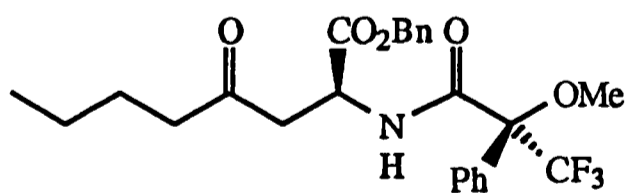

The general procedure with (2*S*)-benzyl 2-amino-4-oxooctanoate (**225**) (21mg, 0.08mmol.) and (*S*)-Mosher's acid chloride afforded the (*S,R*) Mosher's acid derivative (**227**) (50mg crude mass) as a yellow oil; δ_{H} (200MHz; CDCl_3) 0.89 (3H, t, J 7Hz, CH_3), 1.20-1.59 (4H, m, $\text{CH}_2\text{CH}_2\text{CH}_2\text{CH}_3$), 2.40 (2H, t, J 8Hz, $\text{CH}_2\text{CH}_2\text{CH}_2\text{CH}_3$), 2.85-3.20 (2H, m, CH_2CH), 3.29 (3H, s, OCH_3), 4.85 (1H, td, J 4Hz, J 8Hz, CH_2CH), 5.12 and

5.18 (2H, ABq, J_{AB} 13Hz, $\text{CH}_2(\text{C}_6\text{H}_5)$), 7.31-7.63 (10H, m, 2 x (C_6H_5)) and 7.94 (1H, d, J 8Hz, NH); δ_{F} (235MHz; CDCl_3) -71.14 (s, CF_3).

(2S)-Benzyl-2-amino-4-oxopentanoate (202)

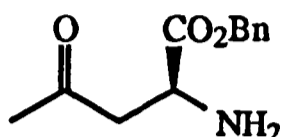

A solution of (2S)-benzyl *N*-(*t*-butoxycarbonyl)-2-amino-4-oxopentanoate (159) (15mg, 0.05mmol.) in TFA (2ml) was stirred at room temperature for fifteen minutes and then concentrated *in vacuo*. The residue was taken up in saturated aqueous NaHCO_3 (40ml) and extracted with ethylacetate (2 x 20ml). The organics were combined, dried (MgSO_4), filtered and concentrated *in vacuo* to afford (2S)-benzyl-2-amino-4-oxopentanoate (202) (9mg, quant.) as a pale yellow oil; δ_{H} (200MHz; CDCl_3) 2.18 (3H, s, $\text{C}(\text{O})\text{CH}_3$), 2.89-2.95 (2H, m, CH_2CH), 3.70-3.91 (1H, m, CH_2CH), 5.18 ($\text{CH}_2(\text{C}_6\text{H}_5)$) and 7.32-7.40 (5H, m, $\text{CH}_2(\text{C}_6\text{H}_5)$).

(3S)-1-Phenylsulfonyl-3-hydroxybutane (240)

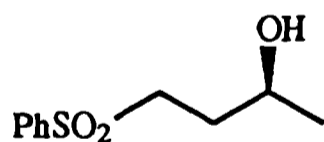

To a stirred solution of methylphenylsulfone (178) (700mg, 4.49mmol.) in anhydrous THF (10ml), under an inert atmosphere of argon, and cooled to -78°C was added *n*-butyllithium (3.1ml, 4.49mmol.). The reaction mixture was stirred at -78°C for fifteen minutes and then at 0°C for ten minutes before being re-cooled to -78°C whereupon (*S*)-propylene oxide (471 μl , 6.73mmol.) was added. The mixture was allowed to warm to room temperature over one hour and then stirred at room temperature for a further sixteen hours before being quenched by the addition of saturated aqueous NH_4Cl (10ml) and being diluted

with dichloromethane (80ml), washed with saturated aqueous NH_4Cl (30ml) and saturated aqueous brine (30ml), dried (MgSO_4), filtered and concentrated *in vacuo* to yield a yellow oil. Flash chromatography (SiO_2 , dichloromethane:ether; 80:20) afforded (3*S*)-1-phenylsulfonyl-3-hydroxybutane (240) as a colourless oil (814mg, 85%), (R_f 0.3, dichloromethane:ether; 80:20), (Found: C, 56.19; H, 6.85. $\text{C}_{10}\text{H}_{14}\text{O}_3\text{S}$ requires C, 56.05; H, 6.56%); $[\alpha]_D +22.8^\circ$ (c 1.0 in CHCl_3); ν_{max} (FT IR, Thin film, NaCl plates) 3512 br m (OH), 3065m, 2970m, 1448s, 1407s, 1377m, 1304s, 1231m, 1146s, 1087s, 1025m, 936s, 795s, 745s and 690s cm^{-1} ; δ_{H} (200MHz; CDCl_3) 1.22 (3H, d, J 6Hz, CH_3), 1.75-2.05 (2H, m, CH_2CH), 3.11-3.99 (2H, m, $\text{CH}_2\text{SO}_2(\text{C}_6\text{H}_5)$), 3.85-4.02 (1H, m, CHOH), 7.52-7.73 (3H, m, *meta* and *para* $\text{SO}_2(\text{C}_6\text{H}_5)$) and 7.90-7.95 (2H, m, *ortho* $\text{SO}_2(\text{C}_6\text{H}_5)$); δ_{C} (50MHz; CDCl_3) 23.28 (CH_3), 31.39 (CH_2CH), 53.03 ($\text{CH}_2\text{SO}_2(\text{C}_6\text{H}_5)$), 65.85 (CHOH), 128.10, 129.54 and 134.02 (aromatic CH) and 139.08 (aromatic *ipso* C); m/z (chemical ionisation, NH_3) 232[(MNH_4) $^+$, 100%], 215[(MH) $^+$, 5], 197[53], 94[9] and 78[25].

(3*R*)-1-Phenylsulfonyl-3-hydroxybutane (253)

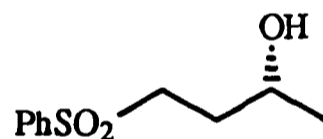

The procedure above with methylphenylsulfone (178) (753mg, 4.83mmol.) and (*R*)-propylene oxide afforded (3*R*)-1-phenylsulfonyl-3-hydroxybutane (253) as a colourless oil (902mg, 87%); $[\alpha]_D -23.4$ (c 1.0 in CHCl_3). All other physical and spectroscopic data were identical to those given for (240) above.

(3*RS*) 1-Phenylsulfonyl 3-*t*-butyldiphenylsilyloxybutane (197)

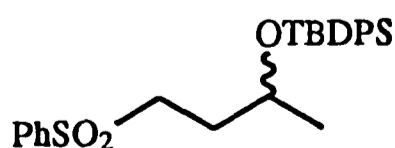

To a stirred solution of (3*RS*)-1-phenylsulfonyl-3-hydroxybutane (192) (606mg, 2.83mmol.) in anhydrous DMF (5ml), under an inert atmosphere of argon, was added *t*-butyldiphenylsilylchloride (934mg, 3.36mmol.) as a solution in anhydrous DMF (10ml) and imidazole (482mg, 7.08mmol.) The reaction mixture was then left to stir at 35°C for fifteen hours before being concentrated *in vacuo* and the residue being taken up in dichloromethane (60ml), washed with 1M HCl (2 x 30ml), saturated aqueous NaHCO₃ (30ml), saturated aqueous brine (30ml), dried (MgSO₄), filtered and concentrated *in vacuo* to yield a yellow oil. Flash chromatography (SiO₂, P.E. 30-40:ether; 80:20) afforded (3*RS*)-1-phenylsulfonyl 3-*t*-butyldiphenylsilyloxybutane (197) as a colourless oil (1.21g, 96%), (R_f 0.3, P.E. 30-40:ether; 80:20), (Found: C, 68.74; H, 7.41. C₂₆H₃₂O₃SSi requires C, 68.99; H, 7.12%); ν_{max} (FT IR, Thin film, NaCl plates) 3071m (NH), 2958s, 2931s, 2858s, 1473s, 1463s, 1448s, 1428s, 1307s, 1148s, 1112s, 1088s, 1073s, 999s, 823s, 742s and 704s cm⁻¹; δ_H (200MHz; CDCl₃) 1.00 (9H, s, SiC(CH₃)₃), 1.04 (3H, d, *J* 6Hz, CHCH₃), 1.70-1.89 (2H, m, CH₂CH(OSi(C₆H₅)₂C(CH₃)₃)), 3.01-3.22 (2H, m, CH₂SO₂(C₆H₅)), 3.81-3.95 (1H, m, CH(OSi(C₆H₅)₂C(CH₃)₃)) and 7.25-7.80 (10H, m, Si(C₆H₅)₂); δ_C (50MHz; CDCl₃) 19.05 (SiC(CH₃)₃), 22.81 (CHCH₃), 26.82 (SiC(CH₃)₃), 31.78 (CH₂CH(OSi(C₆H₅)₂C(CH₃)₃)), 52.35 (CH₂SO₂(C₆H₅)), 67.50 (CH(OSi(C₆H₅)₂C(CH₃)₃)), 127.77, 127.91, 128.23, 129.93, 130.01, 133.80, 135.92 and 136.00 (aromatic CH) and 135.00 and 139.25 (2 x aromatic *ipso* C); m/z (chemical ionisation, NH₃) 470[(MNH₄)⁺, 10%], 453[(MH)⁺, 10], 395[90], 375[100], 259[10], 197[21], 77[11] and 57[12].

(3*S*)-1-Phenylsulfonyl 3-*t*-butyldimethylsilyloxybutane (241)

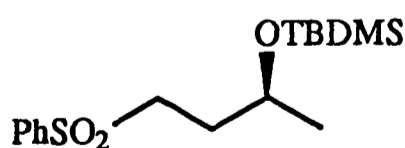

To a stirred solution of (3*S*)-1-phenylsulfonyl-3-hydroxybutane (240) (780mg, 3.64mmol.) in anhydrous DMF (25ml), under an inert atmosphere of argon, was added

^tbutyldimethylsilylchloride (660mg, 4.37mmol., 1.2 eq.) and imidazole (620mg, 9.11mmol., 2.5 eq.) The reaction mixture was then left to stir at 35°C for fourteen hours before being concentrated *in vacuo* and the residue being taken up in dichloromethane (80ml), washed with 1M HCl (2 x 40ml), saturated aqueous NaHCO₃ (40ml), saturated aqueous brine (40ml), dried (MgSO₄), filtered and concentrated *in vacuo* to yield a yellow oil. Flash chromatography (SiO₂, P.E. 30-40:ether; 80:20) afforded (3*S*)-1-phenylsulfonyl 3-^tbutyldimethylsilyloxybutane (241) as a colourless oil (1.16g, 97%), (R_f 0.3, P.E. 30-40:ether; 80:20), (Found: C, 58.53; H, 8.88. C₁₆H₂₈O₃SSi requires C 58.49; H, 8.59%); [α]_D +11.7 (c 1.0 in CHCl₃); ν_{max} (FT IR, Thin film, NaCl plates) 2956s, 2931s, 2857s, 2742s, 1448s, 1307s, 1148s, 1088s, 1021s, 838s, 777s and 690s cm⁻¹; δ_H (200MHz; CDCl₃) -0.01 and 0.01 (6H, 2 x s, Si(CH₃)₂), 0.83 (9H, s, SiC(CH₃)₃), 1.10 (3H, d, *J* 6Hz, CHCH₃), 1.71-1.93 (2H, m, CH₂CH(OSi(CH₃)₂C(CH₃)₃)), 3.20-3.32 (2H, m, CH₂SO₂(C₆H₅)), 3.80-3.90 (1H, m, CH(OSi(CH₃)₂C(CH₃)₃)), 7.53-7.70 (3H, m, *meta* and *para* SO₂(C₆H₅)) and 7.89-7.93 (2H, m, *ortho* SO₂(C₆H₅)); δ_C (50MHz; CDCl₃) -5.16 and -4.65 (Si(CH₃)₂), 17.74 (SiC(CH₃)₃), 23.28 (CHCH₃), 25.60 (SiC(CH₃)₃), 33.01 (CH₂CH(OSi(CH₃)₂C(CH₃)₃)), 52.60 (CH₂SO₂(C₆H₅)), 66.40 (CH(OSi(CH₃)₂C(CH₃)₃)), 128.16, 129.45 and 138.84 (aromatic CH) and 139.26 (aromatic *ipso* C); m/z (chemical ionisation, NH₃) 329[(MH)⁺, 100%], 271[66], 197[66], 152[20], 135[30], 90[18] and 74[22].

(3*R*)-1-Phenylsulfonyl 3-^tbutyldimethylsilyloxybutane (254)

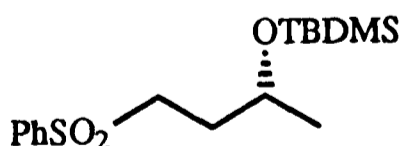

The above procedure with (3*R*)-1-phenylsulfonyl-3-hydroxybutane (253) (880mg, 4.11mmol.) afforded (3*R*)-1-phenylsulfonyl 3-^tbutyldimethylsilyloxybutane (254) as a colourless oil (1.31g, 97%); [α]_D -11.0 (c 1 in CHCl₃). All other physical and spectroscopic data were identical to those given for (241) above.

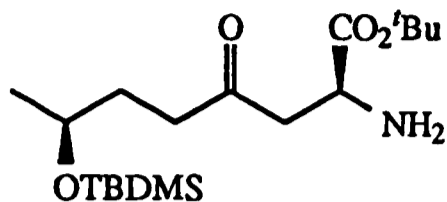
(2*S*, 7*S*)-^tButyl-2-amino-7-^tbutyldimethylsilyloxy-4-oxooctanoate (244a)

To a stirred suspension of 5% Pd/CaCO₃ in ethylacetate (1ml) was added (2*S*, 7*S*)-^tbutyl *N*-(benzyloxycarbonyl) 2-amino-7-^tbutyldimethylsilyloxy-4-oxooctanoate (243a) (212mg, 0.43mmol.) as a solution in ethylacetate (1ml). The resulting mixture was stirred under an atmosphere of H₂ for one hour before being filtered through a plug of Celite® and concentrated *in vacuo* to afford (2*S*, 7*S*)-^tbutyl-2-amino-7-^tbutyldimethylsilyloxy-4-oxooctanoate (244a) as a white foam (153mg, quant.); δ_H (200MHz; CDCl₃) 0.04 and 0.05 (6H, 2 x s, Si(CH₃)₂), 0.89 (9H, s, SiC(CH₃)₃), 1.13 (3H, d, *J* 6Hz, CH(OSi(CH₃)₂C(CH₃)₃)CH₃), 1.46 (9H, s, CHCO₂C(CH₃)₃), 1.59-1.80 (2H, m, CH₂CH(OSi(CH₃)₂C(CH₃)₃)CH₃), 2.18 (2H, br s, NH₂), 2.38-2.64 (2H, m, CH₂CH₂CH(OSi(CH₃)₂C(CH₃)₃)CH₃), 2.80-3.00 (2H, m, CH₂CHCO₂C(CH₃)₃) and 3.72-3.89 (2H, m, CH(OSi(CH₃)₂C(CH₃)₃) and CH₂CHCO₂C(CH₃)₃).

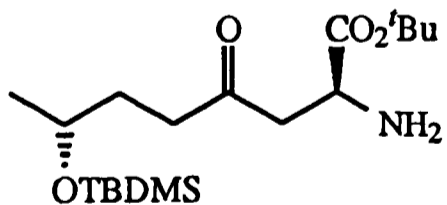
(2*S*, 7*R*)-^tButyl-2-amino-7-^tbutyldimethylsilyloxy-4-oxooctanoate (244b)

The above procedure with (2*S*, 7*R*)-^tbutyl *N*-(benzyloxycarbonyl)-2-amino-7-^tbutyldimethylsilyloxy-4-oxooctanoate (243b) (187mg, 0.38mmol.) afforded (2*S*, 7*R*)-^tbutyl-2-amino-7-^tbutyldimethylsilyloxy-4-oxooctanoate (244b) as a white foam (136mg, quant.); δ_H (200MHz; CDCl₃) 0.05 (6H, 2 x s, Si(CH₃)₂) 0.89 (9H, s, SiC(CH₃)₃), 1.13 (3H, d, *J* 6Hz, CH(OSi(CH₃)₂C(CH₃)₃)CH₃), 1.47 (9H, s, CHCO₂C(CH₃)₃), 1.55-1.80 (2H, m, CH₂CH(OSi(CH₃)₂C(CH₃)₃)CH₃), 2.40-2.51 (2H, m,

$\text{CH}_2\text{CH}_2\text{CH}(\text{OSi}(\text{CH}_3)_2\text{C}(\text{CH}_3)_3)\text{CH}_3$, 2.95-3.27 (4H, m, NH_2 and $\text{CH}_2\text{CHCO}_2\text{C}(\text{CH}_3)_3$) and 3.72-3.98 (2H, m, $\text{CH}(\text{OSi}(\text{CH}_3)_2\text{C}(\text{CH}_3)_3$ and $\text{CH}_2\text{CHCO}_2\text{C}(\text{CH}_3)_3$).

(S)-Benzyl 2-hydroxypropanoate (233)

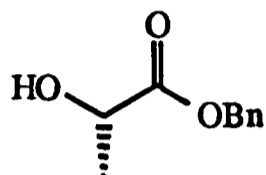

To a stirred solution of (*L*)-lactic acid lithium salt (813mg, 8.47mmol.) in anhydrous DMF (20ml), under an inert atmosphere of argon, was added benzylbromide (5.04ml, 42.3mmol., 5 eq.). The reaction mixture was then stirred at 40°C for forty eight hours before being concentrated *in vacuo*. The residue was taken up in ether (150ml) and washed with water (50ml), saturated aqueous NaHCO_3 (50ml) and saturated aqueous brine (50ml), then dried (MgSO_4), filtered and concentrated *in vacuo* to yield a yellow oil. Flash chromatography (SiO_2 , P.E 30-40:ether; 70:30, 50:50, gradient elution) afforded (*S*)-benzyl 2-hydroxypropanoate (233) as a colourless oil (1.45g, 95%), (R_f 0.2, P.E 30-40:ether; 70:30), (Found: C, 66.32; H, 6.67. $\text{C}_{10}\text{H}_{12}\text{O}_3$ requires C, 66.65; H, 6.71%); $[\alpha]_D -13.6$ (c 1 in CHCl_3); ν_{max} (FT IR, Thin film, NaCl plates) 3457br s (OH), 2984m, 2939m, 1741s (C=O), 1499m, 1456s, 1265s, 1215s, 1083m, 752s and 699s cm^{-1} ; δ_{H} (200MHz; CDCl_3) 1.45 (3H, d, J 7Hz, CH_3), 2.82 (1H, d J 5Hz, OH), 4.34 (1H, dq, J 5Hz, J 7Hz, CHCH_3), 5.23 (2H, s, $\text{CO}_2\text{CH}_2(\text{C}_6\text{H}_5)$) and 7.39 (5H, s, $\text{CO}_2\text{CH}_2(\text{C}_6\text{H}_5)$); δ_{C} (50MHz; CDCl_3) 20.18 (CH_3), 66.90 (CHCH_3), 67.09 ($\text{CO}_2\text{CH}_2(\text{C}_6\text{H}_5)$), 128.43, 128.67 and 128.85 (aromatic CH), 135.65 (aromatic *ipso* C) and 175.84 ($\text{CO}_2\text{CH}_2(\text{C}_6\text{H}_5)$); m/z (chemical ionisation, NH_3) 198[(MNH_4)⁺, 100%], 181[(MH)⁺, 20], 108[45] and 91[50].

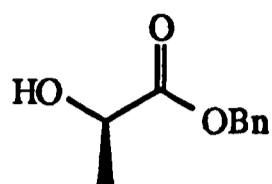
(R)-Benzyl 2-hydroxypropanoate (246)

The above procedure with (*D*)-lactic acid lithium salt (525mg, 8.47mmol.) afforded (*R*)-benzyl 2-hydroxypropanoate (246) as a colourless oil (804g, 82%); $[\alpha]_D +14.0$ (*c* 1 in CHCl_3). All other physical and spectroscopic data were identical to that obtained for (233) above.

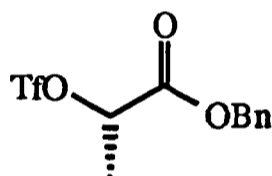
(S)-Benzyl 2-trifluoromethanesulfonyloxypropanoate (234)^{19,126}

To a stirred solution of (*S*)-benzyl 2-hydroxypropanoate (233) (93mg, 0.52mmol.) in anhydrous dichloromethane (1ml), under an inert atmosphere of argon, and cooled to 0°C was added pyridine (42μl, 0.52mmol., 1eq.) followed by trifluoromethanesulfonic anhydride (87μl, 0.52mmol., 1eq.). The reaction mixture was stirred at 0°C for twenty minutes and then filtered through a cotton wool plug and concentrated *in vacuo*. The residue was taken up in P.E. 30-40 and passed through a plug of flash silica (P.E. 30-40 eluent). Concentration *in vacuo* afforded (*S*)-benzyl 2-trifluoromethanesulfonyloxypropanoate (234) as a colourless oil (100mg, 65%), (R_f 0.8, P.E 30-40:ether; 50:50); $[\alpha]_D -37.5$ (*c* 1.25 in CHCl_3); ν_{max} (FT IR, CDCl_3 solution, NaCl plates) 2960m, 1762s (C=O), 1421s, 1309m, 1247s, 1220s, 1147m and 954m cm^{-1} ; δ_{H} (200MHz; CDCl_3) 1.72 (3H, d, J 7Hz, CH_3), 5.29 (3H, s, $\text{CO}_2\text{CH}_2(\text{C}_6\text{H}_5)$) overlapping with 5.20-5.35 (1H, m, CHCH_3) and 7.34 (5H, s, $\text{CO}_2\text{CH}_2(\text{C}_6\text{H}_5)$); δ_{C} (50MHz; CDCl_3) 17.84 (CH_3), 68.29 ($\text{CO}_2\text{CH}_2(\text{C}_6\text{H}_5)$), 80.08 (CHCH_3), 118.64 (q, J_{CF} 321Hz, CF_3), 128.60, 128.93 and 129.03 (aromatic CH),

134.64 (aromatic *ipso* C) and 167.58 (CO₂CH₂(C₆H₅)); m/z (chemical ionisation, NH₃) 330[(MNH₄)⁺, 100%], 108[20] and 91[54].

(R)-Benzyl 2-trifluoromethanesulfonyloxypropanoate (247)

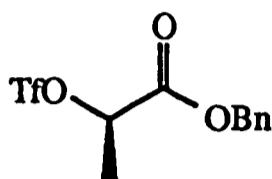

The above procedure with (*R*)-benzyl 2-hydroxypropanoate (246) (200mg, 1.1mmol.) afforded (*R*)-benzyl 2-trifluoromethanesulfonyloxypropanoate (247) as a colourless oil (260mg, 75%), (*R_f* 0.8, P.E 30-40:ether; 50:50); [α]_D +38.1 (*c* 1.25 in CHCl₃). All other physical and spectroscopic data were identical to that given for (234) above.

General procedures for the preparation of (238), (20a), (20b), *ent*-(20c) and *ent*-(20d) from (196), (244a) and (244b)

General procedure for the coupling of alanine affording (235) and (248)

To a stirred solution of amine (196), (244a) or (244b) in anhydrous dichloromethane (*ca.* 7ml per mmol. of amine), under an inert atmosphere of argon, was added triethylamine (2eq.) followed by (*R*) or (*S*)-benzyl α -trifluoromethanesulfonyloxy propanoate (2eq.) as a solution in anhydrous dichloromethane (*ca.* 5ml per mmol of amine). The resulting mixture was stirred at room temperature for twelve hours before being diluted with dichloromethane and washed with water, dried (MgSO₄), filtered and concentrated *in vacuo*.

General procedure for the hydrogenolysis of (235) and (248) to afford (236) and (249) respectively

To a stirred suspension of 10% Pd/C (cat.) in ethylacetate (*ca.* 3ml per mmol. of ester) was added (235) or (248) as a solution in ethylacetate (*ca.* 3ml per mmol. of ester).

The resulting mixture was stirred under an atmosphere of H₂ for one hour before being filtered through a plug of Celite[®] and concentrated *in vacuo*.

General procedure for the coupling of tyrosine to (236) and (249) to afford (237) and (250) respectively

To a stirred solution of (236) or (249) in anhydrous dichloromethane (*ca.* 4ml per mmol of carboxylic acid), under an inert atmosphere of argon, was added 1-hydroxybenzotriazole (1.1eq.), DCC (1.1eq.) and tyrosine ^tbutylester (1eq.). The reaction mixture was then stirred at room temperature for one hour before being diluted with DCM washed with 1M HCl, saturated aqueous NaHCO₃ and saturated aqueous brine. The organics were dried (MgSO₄), filtered and concentrated *in vacuo*.

General procedure for full deprotection. Preparation of (238), (20a), (20b), *ent*-(20c) and *ent*-(20d)

To a stirred solution of (237) or (250) (*ca.* 30mg, 0.046mmol.) in anisole (0.5ml) was added TFA (2ml) and the mixture was stirred at room temperature for two hours before being concentrated *in vacuo*. The residue was taken up in water (30ml) and washed with Et₂O (10ml). The aqueous layer was then lyophilised three times. Further purification could be obtained by h.p.l.c. as indicated by Ando *et al.*¹

Synthesis of (238)

N-((6*RS*)-6-^tButyldimethylsilyloxy-1-^tbutyloxycarbonyl-3-oxoheptyl)-*D*-alanine benzyl ester (235)

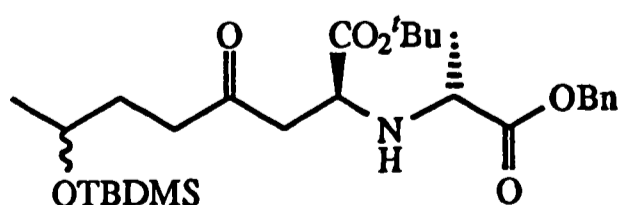

The general procedure with (2*S*, 7*RS*)-^tbutyl 2-amino-7-^tbutyldimethylsilyloxy-4-oxooctanoate (196) (74mg, 0.21mmol.) and (*S*)-benzyl α -trifluoromethanesulfonyloxy

propanoate (**234**) followed by flash chromatography (SiO₂, P.E 30-40:ether; 80:20) afforded *N*-((6*RS*)-6-*t*-butyldimethylsilyloxy-1-*t*-butyloxycarbonyl-3-oxoheptyl)-*D*-alanine benzyl ester (**245**) as a colourless oil (97mg, 90%), (R_f 0.2, P.E 30-40:ether; 80:20); ν_{\max} (FT IR, Thin film, NaCl plates) 3338br m, 2957s, 2931s, 2857s, 1738s (C=O), 1473s, 1456s and 1153s cm⁻¹; δ_{H} (200MHz; CDCl₃) 0.04 and 0.05 (6H, 2 x s, Si(CH₃)₂), 0.88 (9H, s, SiC(CH₃)₃), 1.12 (3H, d, *J* 6Hz, CH(OSi(CH₃)₂C(CH₃)₃)CH₃), 1.29 (3H, d, *J* 7Hz, NHCHCH₃), 1.43 (9H, s, CH₂CHCO₂C(CH₃)₃), 1.58-1.81 (2H, m, CH₂CH(OSi(CH₃)₂C(CH₃)₃)CH₃), 2.33-2.58 (2H, m, CH₂CH₂CH(OSi(CH₃)₂C(CH₃)₃)CH₃), 2.59-2.84 (2H, m, CH₂CHCO₂C(CH₃)₃), 3.37-3.53 (1H, m, CH(OSi(CH₃)₂C(CH₃)₃)CH₃), 3.63 (1H, t, *J* 6 Hz, NHCHCH₃), 3.72-3.90 (1H, m, CH₂CHCO₂C(CH₃)₃), 5.10 and 5.18 (2H, ABq, *J* 17 Hz, NHCHCO₂CH₂(C₆H₅)) and 7.36 (5H, s, NHCHCO₂CH₂(C₆H₅)); δ_{C} (50MHz; CDCl₃) -4.72 and -4.39 (Si(CH₃)₂), 18.05 (SiC(CH₃)₃), 18.79 and 23.60 (CH(OSi(CH₃)₂C(CH₃)₃)CH₃ and NHCHCH₃), 25.86 and 27.99 (CH₂CHCO₂C(CH₃)₃ and SiC(CH₃)₃), 33.01 (CH₂CH(OSi(CH₃)₂C(CH₃)₃)CH₃), 39.39 (CH₂CH₂CH(OSi(CH₃)₂C(CH₃)₃)CH₃), 46.24 (CH₂CHCO₂C(CH₃)₃), 55.17 and 56.14 (NHCHCH₃ and CH₂CHCO₂C(CH₃)₃), 67.55 and 67.56 (CH(OSi(CH₃)₂C(CH₃)₃)), 67.59 (NHCHCO₂CH₂(C₆H₅)), 81.56 (CHCO₂C(CH₃)₃), 128.09, 128.19 and 128.53 (aromatic CH), 135.93 (aromatic *ipso* C), 172.66, 172.69 and 174.62 (CH₂CHCO₂C(CH₃)₃ and NHCHCO₂CH₂(C₆H₅)) and 207.89 (C(O)CH₂CH₂CH(OSi(CH₃)₂C(CH₃)₃)CH₃); *m/z* (chemical ionisation, NH₃) 522[(MH)⁺, 100%], 420[20], 288[41], 236[20], 173[13], 91[68] and 70[13].

N-((6*RS*)-6-*t*-Butyldimethylsilyloxy-1-*t*-butyloxycarbonyl-3-oxoheptyl)-*D*-alanine (**236**)

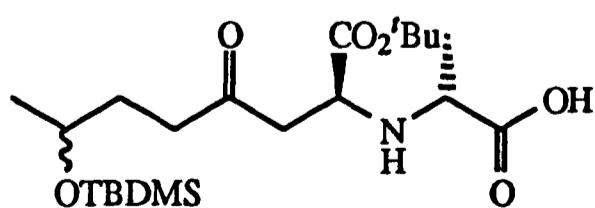

The general procedure with *N*-((6*RS*)-6-*t*-butyldimethylsilyloxy-1-*t*-butyloxycarbonyl-3-oxoheptyl)-*D*-alanine benzyl ester (**235**) (47mg, 0.09mmol.) afforded *N*-((6*RS*)-6-

t-butyldimethylsilyloxy-1-*t*-butyloxycarbonyl-3-oxoheptyl)-*D*-alanine (236) as a white foam (39mg, quant.); ν_{\max} (FT IR, CDCl₃ solution, NaCl plates) 2897m, 2858m, 1718s (C=O), 1332s, 1257s, 1153s, 927s, 922s and 838s cm⁻¹; δ_{H} (200MHz; CDCl₃) 0.04 and 0.05 (6H, 2 x s, Si(CH₃)₂), 0.89 (9H, s, SiC(CH₃)₃), 1.13 (3H, d, *J* 6Hz, CH(OSi(CH₃)₂C(CH₃)₃)CH₃), 1.47 (12H, m, CH₂CHCO₂C(CH₃)₃ and NHCHCH₃), 1.62-1.85 (2H, m, CH₂CH(OSi(CH₃)₂C(CH₃)₃)CH₃), 2.45-2.61 (2H, m, CH₂CH₂CH(OSi(CH₃)₂C(CH₃)₃)CH₃), 2.92-3.04 (2H, m, CH₂CHCO₂C(CH₃)₃), 3.37-3.48 (1H, m, NHCHCH₃), 3.72-3.90 (2H, m, CH(OSi(CH₃)₂C(CH₃)₃)) and CH₂CHCO₂C(CH₃)₃) and 5.15-5.50 (2H, br s, NH and OH); δ_{C} (125MHz; CDCl₃) -4.72 and -4.41 (Si(CH₃)₂), 16.90 (SiC(CH₃)₃), 18.03 (CH(OSi(CH₃)₂C(CH₃)₃)CH₃), 23.60 (NHCHCH₃), 25.85 and 27.88 (CH₂CHCO₂C(CH₃)₃ and SiC(CH₃)₃), 32.88 (CH₂CH(OSi(CH₃)₂C(CH₃)₃)CH₃), 38.87 and 38.95 (CH₂CH₂CH(OSi(CH₃)₂C(CH₃)₃)CH₃), 43.87 (CH₂CHCO₂C(CH₃)₃), 55.67 and 56.26 (NHCHCH₃ and CH₂CHCO₂C(CH₃)₃), 67.41 and 67.49 (CH(OSi(CH₃)₂C(CH₃)₃)), 83.06 (CH₂CHCO₂C(CH₃)₃), 170.60 and 175.11 (NHCHCO₂H and CH₂CHCO₂C(CH₃)₃) and 207.86 (C(O)CH₂CH₂CH(OSi(CH₃)₂C(CH₃)₃)CH₃); *m/z* (desorption chemical ionisation, NH₃) 432[(MH)⁺, 9%], 343[68], 287[13], 229[25], 211[58], 155[19], 116[11] and 90[100].

N-((6*RS*)-6-*t*-Butyldimethylsilyloxy-1-*t*-butyloxycarbonyl-3-oxoheptyl)-*D*-alanyl-*L*-tyrosine *t*-butylester (237)

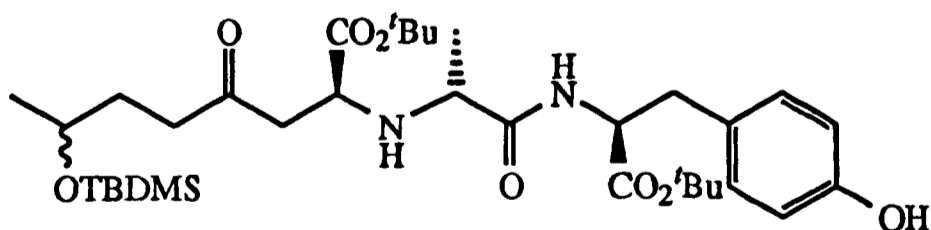

The general procedure with *N*-((6*RS*)-6-*t*-butyldimethylsilyloxy-1-*t*-butyloxycarbonyl-3-oxoheptyl)-*D*-alanine (236) (32mg, 0.07mmol.) and (*L*)-tyrosine *t*-butylester followed by flash chromatography (SiO₂, P.E. 30-40:ether; 30:70) afforded *N*-((6*RS*)-6-

t-butyldimethylsilyloxy-1-*t*-butyloxycarbonyl-3-oxoheptyl)-*D*-alanyl-*L*-tyrosine^{*t*}butylester (237) as a colourless oil (34mg, 70%), (R_f 0.2, P.E 30-40:ether; 20:80); ν_{max} (FT IR, CDCl₃ solution, NaCl plates) 2931m, 1728s (C=O), 1669s, 1615s, 1515s, 1371m, 1257m, 1156s, 892s, 839s and 778s cm⁻¹; δ_H (500MHz; CDCl₃) 0.07 (6H, s, Si(CH₃)₂), 0.90 and 0.91 (9H, 2 x s, SiC(CH₃)₂), 1.14-1.15 (3H, 2 x d, 2 x J 6Hz, CH(OSi(CH₃)₂C(CH₃)₃)CH₃), 1.24 (3H, d J 7Hz, NHCHCH₃), 1.45 and 1.46 (2 x 9H, 2 x s, CH₂CHCO₂C(CH₃)₃ and NHCHCO₂C(CH₃)₃), 1.60-1.75 (2H, m, CH₂CH(OSi(CH₃)₂C(CH₃)₃)CH₃), 2.39-2.56 (2H, m, CH₂CH₂CH(OSi(CH₃)₂C(CH₃)₃)CH₃), 2.59-2.75 (2H, m, CH₂CHCO₂C(CH₃)₃), 2.91-2.96 (2H, m, 1 x CH₂(C₆H₄)OH), 3.08-3.14 (2H, m, 1 x CH₂(C₆H₄)OH), 3.24-3.31 (1H, m, NHCHCH₃), 3.45-3.52 (1H, m, CH₂CHCO₂C(CH₃)₃), 3.83-3.87 (1H, m, CH(OSi(CH₃)₂C(CH₃)₃)), 4.64-4.68 (1H, m, CHCH₂(C₆H₄)OH), 6.73 and 7.04 (2 x 2H, 2 x d, 2 x J 8.5Hz, (C₆H₄)OH) and 7.65 (1H, d, J 8Hz, NHCH(CO₂C(CH₃)₃)CH₂(C₆H₄)OH); m/z (desorption chemical ionisation, NH₃) 651[(MH)⁺, 3%], 343[50], 309[27], 287[10], 253[100], 229[17], 211[55], 155[12], 136[9] and 89[22].

N-((6*RS*)-6-Hydroxy-1-carboxylic acid-3-oxoheptyl)-*D*-alanyl-*L*-tyrosine (trifluoromethane sulfonate salt) (238)

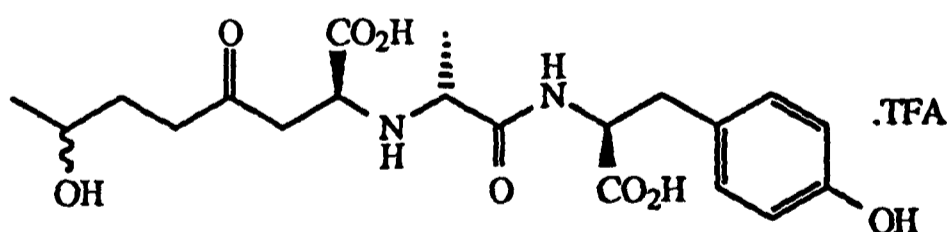

To a stirred solution of *N*-((6*RS*)-6-^{*t*}butyldimethylsilyloxy-1-^{*t*}butyloxycarbonyl-3-oxoheptyl)-*D*-alanyl-*L*-tyrosine^{*t*}butylester (237) (25mg, 0.04mmol.) and anisole (0.5ml) was added TFA (2ml) and the mixture was stirred at room temperature for two hours before being concentrated *in vacuo*. The residue was taken up in water (30ml) and washed with Et₂O (10ml). The aqueous layer was then lyophilised three times to afford *N*-((6*RS*)-6-

hydroxy-1-carboxylic acid-3-oxoheptyl)-D-alanyl-L-tyrosine (trifluoromethane sulfonate salt) (238) as a white powder (16mg, 77%); δ_{H} (200MHz; D₂O) 0.93 (3H, d, J 6Hz, CH(OH)CH₃), 1.09 (3H, d, J 7Hz, NHCHCH₃), 1.40-1.53 (2H, m, CH₂CH(OH)CH₃), 2.30-2.50 (CH₂CH₂CH(OH)CH₃), 2.65 (1H, dd, J 15Hz, J 10Hz, 1 x CH₂(C₆H₄)OH), 2.93-3.10 (4H, m, 1 x CH₂(C₆H₄)OH, CH₂CHCO₂H and CH₂CHCO₂H), 3.51-3.60 (1H, m, CH(OH)CH₃), 3.80-3.93 (1H, m, NHCHCH₃), (CHCH₂(C₆H₄)OH obscured by HOD signal) and 6.62 and 6.93 (2 x 2H, 2 x d, J 8.5 Hz, (CH₂(C₆H₄)OH); δ_{C} (125MHz; CDCl₃) 16.15 and 22.49 (CH(OH)CH₃ and NHCHCH₃), 32.28 (CH₂CH(OH)CH₃), 36.66, 39.04 and 41.62 (CH₂CHCO₂H, CH₂CH₂CH(OH)CH₃ and CH₂(C₆H₄)OH), 54.83, 56.20 and 56.35 (3 x NHCHCO), 67.65 (CH(OH)CH₃), 116.19 and 131.32 (aromatic CH), 129.06 and 155.21 (aromatic ipso C), 170.16, 172.05 and 175.09 (2 x CO₂H and C(O)NH) and 211.74 (C(O)CH₂CH₂CH(OH)CH₃).

Synthesis of (20a)

N-((1*S*, 6*S*)-6-^tButyldimethylsilyloxy-1-^tbutyloxycarbonyl-3-oxoheptyl)-*L*-alanine benzyl ester (248a)

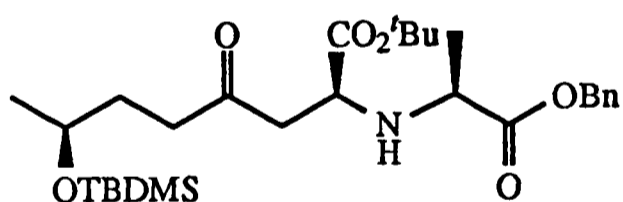

The general procedure with (2*S*, 7*S*)-^tbutyl-2-amino-7-^tbutyldimethylsilyloxy-4-oxo octanoate (244a) (145mg, 0.40mmol.) and (*R*)-benzyl α -trifluoromethanesulfonyloxy propanoate (247) followed by flash chromatography (SiO₂, P.E 30-40:ether; 70:30) afforded *N*-((1*S*, 6*S*)-6-^tbutyldimethylsilyloxy-1-^tbutyloxycarbonyl-3-oxoheptyl)-*L*-alanine benzyl ester (248a) as a colourless oil (190mg, 91%), (R_f 0.25, P.E 30-40:ether; 70:30); $[\alpha]_{\text{D}}$ -8.2 (c 1.3 in CHCl₃); ν_{max} (FT IR, CDCl₃ solution, NaCl plates) 2957m, 2931m, 1738br s (C=O), 1456s, 1369s, 1256s and 776m cm⁻¹; δ_{H} (200MHz; CDCl₃) 0.04 and 0.05 (6H, 2 x s, Si(CH₃)₂) and 0.89 (9H, s, SiC(CH₃)₂), 1.12 (3H, d, J 6Hz, CH(OSi(CH₃)₂C(CH₃)₃)CH₃), 1.34 (3H, d, J 7Hz, NHCHCH₃), 1.45 (9H, s,

CH₂CHCO₂C(CH₃)₃), 1.58-1.85 (2H, m, CH₂CH(OSi(CH₃)₂C(CH₃)₃)CH₃), 2.48 (2H, d of ABq, *J* 6Hz, *J* 15Hz, CH₂CH₂CH(OSi(CH₃)₂C(CH₃)₃)CH₃), 2.70-2.92 (2H, m, CH₂CHCO₂C(CH₃)₃), 3.42-3.63 (2H, m, CH₂CHCO₂C(CH₃)₃ and NHCHCH₃), 3.83 (1H, m, CH(OSi(CH₃)₂C(CH₃)₃)), 5.16 and 5.18 (2H, ABq, *J* 12Hz, NHCHCO₂CH₂(C₆H₅) and 7.28-7.37 (5H, m, NHCHCO₂CH₂(C₆H₅)); δ_C (50MHz; CDCl₃) -4.95 and -4.61 (Si(CH₃)₂), 17.92 (SiC(CH₃)₃), 18.96 and 23.53 (CH(OSi(CH₃)₂C(CH₃)₃)CH₃ and NHCHCH₃), 25.74 and 27.85 (CHCO₂C(CH₃)₃ and SiC(CH₃)₃), 32.80 (CH₂CH(OSi(CH₃)₂C(CH₃)₃)CH₃), 38.81 (CH₂CH₂CH(OSi(CH₃)₂C(CH₃)₃)CH₃), 46.24 (CH₂CHCO₂C(CH₃)₃), 55.40 and 56.21 (NHCHCH₃ and CH₂CHCO₂C(CH₃)₃), 66.49 (NHCHCO₂CH₂(C₆H₅)), 67.49 (CH(OSi(CH₃)₂C(CH₃)₃)CH₃), 81.54 (CHCO₂C(CH₃)₃), 128.34 and 128.74 (aromatic CH), 136.04 (aromatic *ipso* C), 173.19 and 174.97 (CHCO₂C(CH₃)₃ and NHCHCO₂CH₂(C₆H₅)) and 208.75 (C(O)CH₂CH₂CH(OSi(CH₃)₂C(CH₃)₃)CH₃); *m/z* (chemical ionisation, NH₃) 522[(MH)⁺, 100%], 420[10], 288[31], 236[17], 180[20], 173[15], 108[11], 91[52] and 70[10].

N-((1*S*, 6*S*)-6-^tButyldimethylsilyloxy-1-^tbutyloxycarbonyl-3-oxoheptyl)-*L*-alanine (249a)

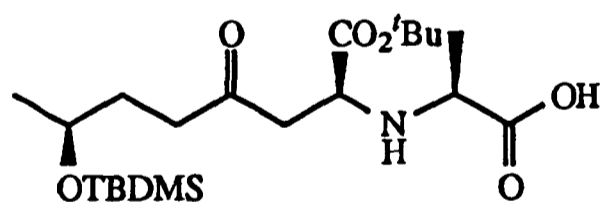

The general procedure with *N*-((1*S*, 6*S*)-6-^tbutyldimethylsilyloxy-1-^tbutyloxycarbonyl-3-oxoheptyl)-*L*-alanine benzyl ester (248a) (170mg, 0.33mmol.) afforded *N*-((1*S*, 6*S*)-6-^tbutyldimethylsilyloxy-1-^tbutyloxycarbonyl-3-oxoheptyl)-*L*-alanine (249a) as a white foam (139mg, quant.), (Found: C, 58.44; H, 9.75; N 3.06. C₂₁H₄₁NO₆Si requires C, 58.44; H, 9.57; N, 3.06%); [α]_D +17.7 (*c* 1.0 in CHCl₃); ν_{max} (FT IR, CDCl₃ solution, NaCl plates) 2957m, 1757s (C=O), 1715m, 1320s and 838m cm⁻¹; δ_H (200MHz; CDCl₃) 0.03 and 0.05 (6H, 2 x s, Si(CH₃)₂), 0.89 (9H, s, SiC(CH₃)₃), 1.12 (3H, d, *J* 6Hz, CH(OSi(CH₃)₂C(CH₃)₃)CH₃), 1.44 (3H, d, *J* 7Hz, NHCHCH₃), 1.47

(9H, s, CH₂CHCO₂C(CH₃)₃), 1.55-1.88 (2H, m, CH₂CH(OSi(CH₃)₂C(CH₃)₃)CH₃), 2.54-2.60 (2H, m, CH₂CH₂CH(OSi(CH₃)₂C(CH₃)₃)CH₃), 2.70-2.95 (2H, m, CH₂CHCO₂C(CH₃)₃), 3.32 (1H, q, *J* 7Hz, NHCHCH₃), 3.42-3.52 (1H, m, CH₂CHCO₂C(CH₃)₃), 3.75-3.90 (1H, m, CH(OSi(CH₃)₂C(CH₃)₃)) and 5.25 (2H, br s, NH and OH); δ_C (125MHz; CDCl₃) -4.95 and -4.58 (Si(CH₃)₂), 17.89 (SiC(CH₃)₃), 18.68 and 23.53 (CH(OSi(CH₃)₂C(CH₃)₃)CH₃ and NHCHCH₃), 25.74 and 27.82 (CH₂CHCO₂C(CH₃)₃ and SiC(CH₃)₃), 32.72 (CH₂CH(OSi(CH₃)₂C(CH₃)₃)CH₃), 38.73 (CH₂CH₂CH(OSi(CH₃)₂C(CH₃)₃)CH₃), 44.64 (CH₂CHCO₂C(CH₃)₃), 56.43 and 56.60 (NHCHCH₃ and CH₂CHCO₂C(CH₃)₃), 67.36 (CH(OSi(CH₃)₂C(CH₃)₃)), 82.92 (CH₂CHCO₂C(CH₃)₃), 171.91 and 175.59 (NHCHCO₂H and CH₂CHCO₂C(CH₃)₃) and 208.78 (C(O)CH₂CH₂CH(OSi(CH₃)₂C(CH₃)₃)CH₃); *m/z* (chemical ionisation, NH₃) 432[(MH)⁺, 20%], 343[23], 211[30], 90[100].

N-((1*S*, 6*S*)-6-^tButyldimethylsilyloxy-1-^tbutyloxycarbonyl-3-oxoheptyl)-*L*-alanyl-*L*-tyrosine ^tbutylester (250a)

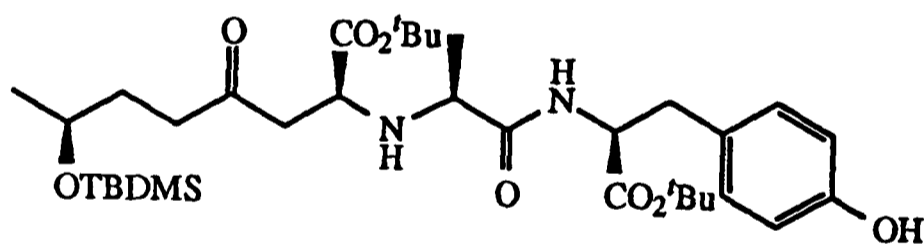

The general procedure with *N*-((1*S*, 6*S*)-6-^tbutyldimethylsilyloxy-1-^tbutyloxycarbonyl-3-oxoheptyl)-*L*-alanine (249a) (119mg, 0.28mmol.) and (*L*)-tyrosine ^tbutylester followed by flash chromatography (SiO₂, P.E. 30-40:ether; 30:70) afforded *N*-((1*S*, 6*S*)-6-^tbutyldimethylsilyloxy-1-^tbutyloxycarbonyl-3-oxoheptyl)-*L*-alanyl-*L*-tyrosine^tbutylester (250a) as a colourless oil (144mg, 79%), (*R*_f 0.2, P.E 30-40:ether; 20:80), *m/z* (high resolution) Found 651.404, C₃₄H₅₈N₂O₈Si+H⁺ requires 651.404; [α]_D -5.8 (*c* 1.0 in CHCl₃); ν_{max} (FT IR, CDCl₃ solution, NaCl plates) 3347br m (NH and OH), 2932s, 2858s, 1728s (C=O), 1657s, 1615s, 1516s, 1451s, 1371s, 1256s, 1156s and 878s cm⁻¹; δ_H (500MHz; CDCl₃) 0.06 and 0.07 (6H, 2 x s, Si(CH₃)₂), 0.89 (9H, s, SiC(CH₃)₂),

1.14 (6H, 2 x d, 2 x J 6Hz, $\text{CH}(\text{OSi}(\text{CH}_3)_2\text{C}(\text{CH}_3)_3)\text{CH}_3$ and NHCHCH_3), 1.43 and 1.46 (2 x 9H, 2 x s, $\text{CH}_2\text{CHCO}_2\text{C}(\text{CH}_3)_3$ and $\text{NHCHCO}_2\text{C}(\text{CH}_3)_3$), 1.61-1.77 (2H, m, $\text{C}\text{H}_2\text{C}\text{H}(\text{O}\text{S}\text{i}(\text{C}\text{H}_3)_2\text{C}(\text{C}\text{H}_3)_3)\text{C}\text{H}_3$), 2.39-2.54 (2H, m, $\text{CH}_2\text{CH}_2\text{CH}(\text{OSi}(\text{CH}_3)_2\text{C}(\text{CH}_3)_3)\text{CH}_3$), 2.75-2.83 (2H, m, $\text{CH}_2\text{CHCO}_2\text{C}(\text{CH}_3)_3$), 3.00 (1H, dd, J 7.5Hz, J 14Hz, 1 x $\text{CH}_2(\text{C}_6\text{H}_4)\text{OH}$), 3.15 (1H, dd, J 5.5Hz, J 14Hz, 1 x $\text{C}\text{H}_2(\text{C}_6\text{H}_4)\text{OH}$), 3.21-3.25 (1H, m, NHCHCH_3), 3.32-3.38 (1H, m, $\text{CH}_2\text{CHCO}_2\text{C}(\text{CH}_3)_3$), 3.83-3.87 (1H, m, $\text{CH}(\text{OSi}(\text{CH}_3)_2\text{C}(\text{CH}_3)_3)\text{CH}_3$), 4.68 (1H, ddd, J 5.5Hz, J 7.5Hz, J 8Hz, $\text{NHCHCH}_2(\text{C}_6\text{H}_4)\text{OH}$), 6.28 (1H, br s, OH), 6.71 and 7.02 (2 x 2H, 2 x d, 2 x J 8.5Hz, $(\text{C}_6\text{H}_4)\text{OH}$) and 7.91 (1H, d, J 8Hz, $\text{NHCH}(\text{CO}_2\text{C}(\text{CH}_3)_3)\text{CH}_2(\text{C}_6\text{H}_4)\text{OH}$); δ_{C} (50MHz; CDCl_3) -4.90 and -4.61 ($\text{Si}(\text{C}\text{H}_3)_2$), 17.92 ($\text{SiC}(\text{CH}_3)_3$), 19.68 and 23.52 ($\text{CH}(\text{OSi}(\text{CH}_3)_2\text{C}(\text{CH}_3)_3)\text{CH}_3$ and NHCHCH_3), 25.75 ($\text{SiC}(\text{CH}_3)_3$), 27.88 ($\text{CH}_2\text{CHCO}_2\text{C}(\text{CH}_3)_3$ and $\text{NHCHCO}_2\text{C}(\text{CH}_3)_3$), 32.80 ($\text{C}\text{H}_2\text{C}\text{H}(\text{O}\text{S}\text{i}(\text{C}\text{H}_3)_2\text{C}(\text{C}\text{H}_3)_3)\text{C}\text{H}_3$), 37.03 and 38.81 ($\text{CH}_2\text{CH}_2\text{CH}(\text{OSi}(\text{CH}_3)_2\text{C}(\text{CH}_3)_3)\text{CH}_3$ and $\text{CH}_2(\text{C}_6\text{H}_4)\text{OH}$) 45.93 $\text{CH}_2\text{CHCO}_2\text{C}(\text{CH}_3)_3$, 53.29, 56.50 and 57.48 (NHCHCH_3 , $\text{CH}_2\text{CHCO}_2\text{C}(\text{CH}_3)_3$ and $\text{CHCH}_2(\text{C}_6\text{H}_4)\text{OH}$), 67.59 ($\text{CH}(\text{OSi}(\text{CH}_3)_2\text{C}(\text{CH}_3)_3)$), 81.93 ($\text{CH}_2\text{CHCO}_2\text{C}(\text{CH}_3)_3$ and $\text{NHCHCO}_2\text{C}(\text{CH}_3)_3$), 115.45 and 130.48 (aromatic CH), 127.65 and 155.03 (2 x aromatic ipso C), 171.23, 173.29 and 175.49 ($\text{CH}_2\text{CHCO}_2\text{C}(\text{CH}_3)_3$, $\text{NHCHCO}_2\text{C}(\text{CH}_3)_3$ and $\text{NHC}(\text{O})$) and 209.07 ($\text{C}(\text{O})\text{CH}_2\text{CH}_2\text{CH}(\text{OSi}(\text{CH}_3)_2\text{C}(\text{CH}_3)_3)\text{CH}_3$); m/z (desorption chemical ionisation, NH_3) 651[(MH)⁺, 10%], 343[42], 309[65], 253[100], 225[50], 211[49], 155[20] and 89[20].

N-((1*S*, 6*S*)-6-Hydroxy-1-carboxylic acid-3-oxoheptyl)-*L*-alanyl-*L*-tyrosine (trifluoromethane sulfonate salt) (20a)

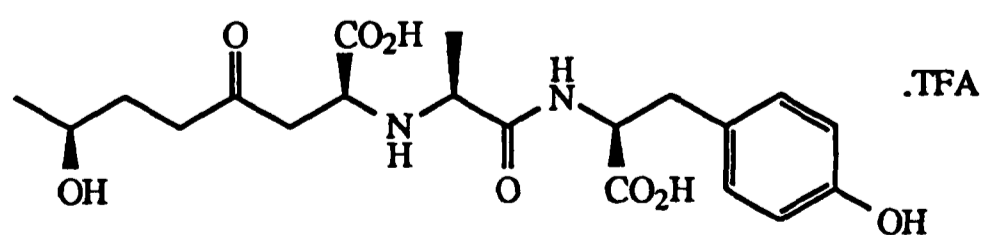

The general procedure with *N*-((6*S*)-6-^tbutyldimethylsilyloxy-1-^tbutyloxycarbonyl-3-oxoheptyl)-*L*-alanyl-*L*-tyrosine^tbutylester (250a) (30mg, 0.046mmol) afforded *N*-((1*S*, 6*S*)-6-hydroxy-1-carboxylic acid-3-oxoheptyl)-*L*-alanyl-*L*-tyrosine (trifluoromethane sulfonate salt) (20a) as a white powder (18mg, 73%). Further purification could be obtained by h.p.l.c according to the method of Ando,¹⁵ m.p. 95-97°C, (Found C, 49.35; H, 5.70; N, 5.40. C₂₂F₃H₂₉N₂O₁₀ requires C, 49.07; H, 5.43; N, 5.20%; [α]_D +14.2 (c 0.375 in H₂O); ν_{max} (FT IR, KBr disc) 3386br m (NH and OH), 1775m, 1717s, 1674s, 1616s, 1518s, 1448s, 1384s, 1201s and 1141s cm⁻¹; δ_H (500MHz; D₂O) 1.05 (3H, d, *J* 6.5Hz, CH(OH)CH₃), 1.42 (3H, d, *J* 7Hz, NHCHCH₃), 1.54-1.60 (2H, m, CH₂CH(OH)CH₃), 2.44 (2H, t, *J* 7.5Hz, CH₂CH₂CH(OH)CH₃), 2.69 (1H, dd, *J* 11Hz, *J* 14Hz, 1 x CH₂(C₆H₄)OH), 2.82-2.88 (2H, m, 1 x CH₂CHCO₂H and CH₂CHCO₂H), 3.03 (1H, dd, *J* 5Hz, *J* 18Hz, 1 x CH₂CHCO₂H), 3.20 (1H, dd, *J* 5Hz, 14Hz, 1 x CH₂(C₆H₄)OH) 3.66-3.70 (1H, m, CH(OH)CH₃), 3.95 (1H, q, *J* 7Hz, NHCHCH₃), (NHCHCO₂H obscured by HOD signal) and 6.73 and 7.06 (4H, 2 x d, 2 x *J* 8.5Hz, (C₆H₄)OH); δ_C (125MHz; CDCl₃) 16.96 and 22.48 (CH(OH)CH₃ and NHCHCH₃), 32.25 (CH₂CH(OH)CH₃), 37.06, 38.82 and 42.40 (CH₂CHCO₂H, CH₂CH₂CH(OH)CH₃ and CH₂(C₆H₄)OH), 55.50, 57.72 and 58.31 (3 x NHCHCO), 67.65 (CH(OH)CH₃), 116.22 and 131.40 (aromatic CH), 129.33 and 155.26 (2 x aromatic *ipso* C), 169.66, 171.45 and 175.00 (CH₂CHCO₂H, NHCHCO₂H and C(O)NH) and 211.55 (C(O)CH₂CH₂CH(OH)CH₃); δ_F (235MHz; CDCl₃) -77.65 (s, CF₃); m/z (FAB) 463[(MK⁺, 6%), 447[(MNa⁺, 10], 407[37], 361[15], 309[35], 253[56], 155[100], 136[21], 107[26], 99[79], 83[20], 70[30] and 55[33].

Synthesis of (20b)

N-((1*S*, 6*R*)-6-^tButyldimethylsilyloxy-1-^tbutyloxycarbonyl-3-oxoheptyl)-*L*-alanine benzyl ester (248b)

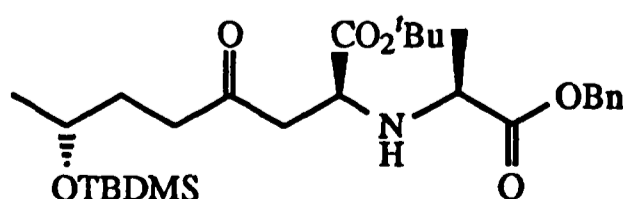

The general procedure with (2*S*, 7*R*)-^tbutyl 2-amino-7-^tbutyldimethylsilyloxy-4-oxooctanoate (244b) (136mg, 0.38mmol.) and (*R*)-benzyl 2-trifluoromethanesulfonyloxypropanoate (247) followed by flash chromatography (SiO₂, P.E 30-40:ether; 70:30) afforded *N*-((1*S*, 6*R*)-6-^tbutyldimethylsilyloxy-1-^tbutyloxycarbonyl-3-oxoheptyl)-*L*-alanine benzyl ester (248b) as a colourless oil (160mg, 81%), (R_f 0.25, P.E 30-40:ether; 70:30), m/z (high resolution) Found 522.325. C₂₈H₄₇NO₆Si+H⁺ requires 522.325; [α]_D -25.7 (c 1.0 in CHCl₃); ν_{max} (FT IR, CDCl₃ solution, NaCl plates) 2957m, 2930m, 1736br s (C=O), 1473s, 1369s, 1153s, 1084m, 837s and 776m cm⁻¹; δ_H (200MHz; CDCl₃) 0.04 and 0.05 (6H, 2 x s, Si(CH₃)₂), 0.89 (9H, s, SiC(CH₃)₂), 1.12 (3H, d, *J* 6Hz, CH(OSi(CH₃)₂C(CH₃)₃)CH₃), 1.33 (3H, d, *J* 7Hz, NHCHCH₃), 1.44 (9H, s, CH₂CHCO₂C(CH₃)₃), 1.55-1.80 (2H, m, CH₂CH(OSi(CH₃)₂C(CH₃)₃)CH₃), 2.42-2.55 (2H, m, CH₂CH₂CH(OSi(CH₃)₂C(CH₃)₃)CH₃), 2.80 (2H, ABq, *J* 12.5Hz, CH₂CHCO₂C(CH₃)₃), 3.50-3.62 (2H, m, CH₂CHCO₂C(CH₃)₃ and NHCHCH₃), 3.75-3.88 (1H, m, CH(OSi(CH₃)₂C(CH₃)₃)), 5.12 and 5.18 (2H, ABq, *J* 15Hz, NHCHCO₂CH₂(C₆H₅) and 7.30 (5H, s, NHCHCO₂CH₂(C₆H₅)); δ_C (50MHz; CDCl₃) -4.97 and -4.61 (Si(CH₃)₂), 17.92 (SiC(CH₃)₃), 18.97 and 23.56 (CH(OSi(CH₃)₂C(CH₃)₃)CH₃ and NHCHCH₃), 25.75 and 27.85 (CO₂C(CH₃)₃ and SiC(CH₃)₃), 32.83 (CH₂CH(OSi(CH₃)₂C(CH₃)₃)CH₃), 38.92 (CH₂CH₂CH(OSi(CH₃)₂C(CH₃)₃)CH₃), 46.30 (CH₂CHCO₂C(CH₃)₃), 55.41 and 56.16 (NHCHCH₃ and CH₂CHCO₂C(CH₃)₃), 66.47 (NHCHCO₂CH₂(C₆H₅)), 67.52 (CH(OSi(CH₃)₂C(CH₃)₃)CH₃), 81.54 (CH₂CHCO₂C(CH₃)₃), 128.38 and 128.74 (aromatic CH), 136.03 (aromatic ipso C), 173.25 and 174.97 (CH₂CHCO₂C(CH₃)₃ and NHCHCO₂CH₂(C₆H₅)) and 208.72 (C(O)CH₂CH₂CH(OSi(CH₃)₂C(CH₃)₃)CH₃); m/z (chemical ionisation, NH₃) 522[(MH)⁺, 8%], 343[10], 236[12], 180[100] and 91[23].

N-((1*S*, 6*R*)-6-^tButyldimethylsilyloxy-1-^tbutyloxycarbonyl-3-oxoheptyl)-*L*-alanine (249b)

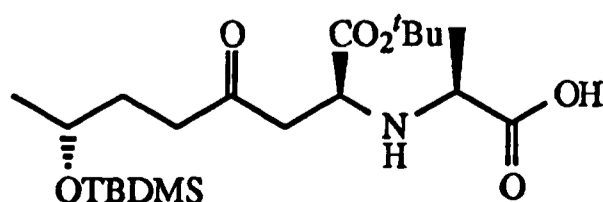

The general procedure with *N*-((1*S*, 6*R*)-6-^tbutyldimethylsilyloxy-1-^tbutyloxycarbonyl-3-oxoheptyl)-*L*-alanine benzyl ester (248b) (140mg, 0.27mmol.) afforded *N*-((1*S*, 6*R*)-6-^tbutyldimethylsilyloxy-1-^tbutyloxycarbonyl-3-oxoheptyl)-*L*-alanine (249b) as a white foam (116mg, quant.); $[\alpha]_D -6.0$ (*c* 0.5 in CHCl₃); ν_{\max} (FT IR, CDCl₃ solution, NaCl plates) 2957m, 1753s and 1718s (C=O), 1372s, 1257s, 1149s, 1030s, 838m and 777s cm⁻¹; δ_H (200MHz; CDCl₃) 0.04 and 0.06 (6H, 2 x s, Si(CH₃)₂), 0.89 (9H, s, SiC(CH₃)₃), 1.14 (3H, d, *J* 6Hz, CH(OSi(CH₃)₂C(CH₃)₃)CH₃), 1.44 (3H, d, *J* 7Hz, NHCHCH₃), 1.48 (9H, s, CH₂CHCO₂C(CH₃)₃), 1.52-1.88 (2H, m, CH₂CH(OSi(CH₃)₂C(CH₃)₃)CH₃), 2.53 (2H, t, *J* 7.5Hz, CH₂CH₂CH(OSi(CH₃)₂C(CH₃)₃)CH₃), 2.65-2.90 (2H, m, CH₂CHCO₂C(CH₃)₃), 3.20 (2H, br s, OH and NH), 3.33 (1H, q, *J* 7Hz, NHCHCH₃), 3.42 (1H, dd, *J* 4Hz, *J* 8Hz, CH₂CHCO₂C(CH₃)₃) and 3.78-3.90 (1H, m, CH(OSi(CH₃)₂C(CH₃)₃)); δ_C (50MHz; CDCl₃) -4.99 and -4.58 (Si(CH₃)₂), 17.92 (SiC(CH₃)₃), 18.94 and 23.56 (CH(OSi(CH₃)₂C(CH₃)₃)CH₃ and NHCHCH₃), 25.74 and 27.85 (CH₂CHCO₂C(CH₃)₃ and SiC(CH₃)₃), 32.73 (CH₂CH(OSi(CH₃)₂C(CH₃)₃)CH₃), 38.79 (CH₂CH₂CH(OSi(CH₃)₂C(CH₃)₃)CH₃), 44.85 (CH₂CHCO₂C(CH₃)₃), 56.56 (NHCHCH₃ and CH₂CHCO₂C(CH₃)₃), 67.28 (CH(OSi(CH₃)₂C(CH₃)₃)), 82.88 (CH₂CHCO₂C(CH₃)₃), 172.24 and 175.62 (NHCHCO₂H and CH₂CHCO₂C(CH₃)₃) and 208.93 (C(O)CH₂CH₂CH(OSi(CH₃)₂C(CH₃)₃)CH₃); *m/z* (chemical ionisation, NH₃) 432[(MH)⁺, 25%], 343[40], 211[27] and 90[100].

N-((1*S*, 6*R*)-6-^tButyldimethylsilyloxy-1-^tbutyloxycarbonyl-3-oxoheptyl)-*L*-alanyl-*L*-tyrosine ^tbutylester (250b)

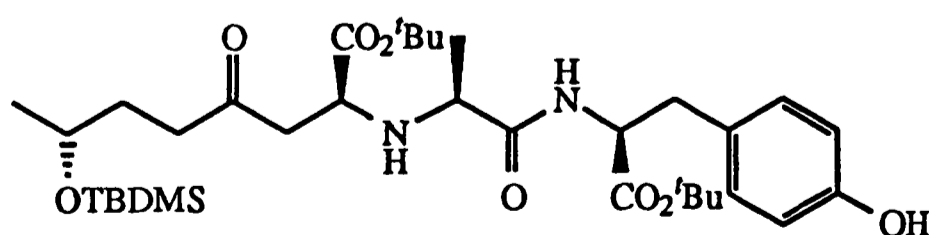

The general procedure with *N*-((1*S*, 6*R*)-6-^tbutyldimethylsilyloxy-1-^tbutyloxycarbonyl-3-oxoheptyl)-*L*-alanine (249b) (95mg, 0.22mmol.) and (*L*)-tyrosine ^tbutylester followed by flash chromatography (SiO₂, P.E. 30-40:ether; 30:70) afforded *N*-((1*S*, 6*R*)-6-^tbutyldimethylsilyloxy-1-^tbutyloxycarbonyl-3-oxoheptyl)-*L*-alanyl-*L*-tyrosine^tbutylester (250b) as a colourless oil (120mg, 84%), (*R*_f 0.3, P.E 30-40:ether; 30:70); [α]_D -32.5 (*c* 0.75 in CHCl₃); ν_{\max} (FT IR, CDCl₃ solution, NaCl plates) 3347s (NH and OH), 2932s, 2858s, 1729s (C=O), 1662s, 1516s, 1371s, 1156s, 911s, 898s and 731s cm⁻¹; δ_{H} (500MHz; CDCl₃) 0.081 and 0.086 (6H, 2 x s, Si(CH₃)₂), 0.91 (9H, s, SiC(CH₃)₂), 1.16 (3H, d, *J* 6Hz, CH(OSi(CH₃)₂C(CH₃)₃)CH₃) 1.18 (3H, d, *J* 7Hz, NHCHCH₃), 1.43 and 1.46 (2 x 9H, 2 x s, CH₂CHCO₂C(CH₃)₃ and NHCHCO₂C(CH₃)₃), 1.60-1.78 (2H, m, CH₂CH(OSi(CH₃)₂C(CH₃)₃)CH₃), 2.40-2.52 (2H, m, CH₂CH₂CH(OSi(CH₃)₂C(CH₃)₃)CH₃), 2.62 (2H, dd, *J* 3.5Hz, *J* 18Hz, 1 x CH₂CHCO₂C(CH₃)₃), 2.83 (1H, dd, *J* 11.5Hz, *J* 18Hz, 1 x CH₂CHCO₂C(CH₃)₃), 3.03 (1H, dd, *J* 7Hz, *J* 14Hz, 1 x CH₂(C₆H₄)OH), 3.08 (1H, dd, *J* 5.5Hz, *J* 14Hz, 1 x CH₂(C₆H₄)OH), 3.23 (1H, q, *J* 7Hz, NHCHCH₃), 3.28-3.31 (1H, m, CH₂CHCO₂C(CH₃)₃), 3.85-3.91 (1H, m, CH(OSi(CH₃)₂C(CH₃)₃)), 4.69 (1H, ddd, *J* 5.5Hz, *J* 7Hz, *J* 9Hz, NHCHCH₂(C₆H₄)OH), 6.72 and 7.02 (2 x 2H, 2 x d, 2 x *J* 8.5Hz, (C₆H₄)OH) and 7.88 (1H, d, *J* 9Hz, NHCH(CO₂C(CH₃)₃)CH₂(C₆H₄)OH); δ_{C} (50MHz; CDCl₃) -4.68 and -4.42 (Si(CH₃)₂), 18.14 (SiC(CH₃)₃), 19.87 and 23.43 (CH(OSi(CH₃)₂C(CH₃)₃)CH₃ and NHCHCH₃), 25.92 (SiC(CH₃)₃), 28.07 and 28.80 (CH₂CHCO₂C(CH₃)₃ and NHCHCO₂C(CH₃)₃), 32.96 (CH₂CH(OSi(CH₃)₂C(CH₃)₃)CH₃), 37.06 and 38.88 (CH₂CH₂CH(OSi(CH₃)₂C(CH₃)₃)CH₃ and CH₂(C₆H₄)OH) 46.07 CH₂CHCO₂C(CH₃)₃), 53.23, 56.71 and 57.74 (NHCHCH₃, CH₂CHCO₂C(CH₃)₃ and CHCH₂(C₆H₄)OH), 67.81 (CH(OSi(CH₃)₂C(CH₃)₃)), 81.79 (NHCHCO₂C(CH₃)₃ and CH₂CHCO₂C(CH₃)₃), 115.39 and 130.51 (aromatic CH), 128.01 and 155.27 (2 x aromatic *ipso* C), 170.83, 173.10 and 175.21 (NHCHCO₂C(CH₃)₃, CH₂CHCO₂C(CH₃)₃ and CO(NH)) and 208.42 (C(O)CH₂CH₂CH(OSi(CH₃)₂C(CH₃)₃)CH₃); *m/z* (desorption chemical ionisation, NH₃)

[651(MH)⁺, 6%], 386[10], 343[35], 309[37], 253[100], 229[20], 211[32], 155[20], 136[11], 89[25].

N-((1*S*, 6*R*)-6-Hydroxy-1-carboxylic acid-3-oxoheptyl)-*L*-alanyl-*L*-tyrosine (trifluoromethane sulfonate salt) (20b)

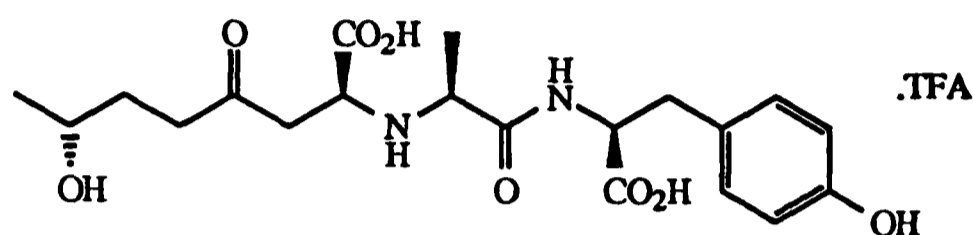

The general procedure with *N*-((6*R*)-6-^tbutyldimethylsilyloxy-1-^tbutyloxycarbonyl-3-oxoheptyl)-*L*-alanyl-*L*-tyrosine^tbutylester (250b) (31mg, 0.048mmol.) afforded *N*-((1*S*, 6*R*)-6-hydroxy-1-carboxylic acid-3-oxoheptyl)-*L*-alanyl-*L*-tyrosine (trifluoromethane sulfonate salt) (20b) as a white powder (19mg, 76%). Further purification can be obtained by h.p.l.c. according to the method of Ando,¹⁵ m.p. 105-107°C; [α]_D +3.9 (c 0.375 in H₂O); ν_{max} (FT IR, KBr disc) 3420br m (NH and OH), 1720s, 1674s, 1616s, 1518s, 1447s, 1384s, 1201s and 1142s cm⁻¹; δ_H (500MHz; D₂O) 1.04 (3H, d, *J* 6.5Hz, CH(OH)CH₃), 1.40 (3H, d, *J* 7Hz, NHCHCH₃), 1.54-1.58 (2H, m, CH₂CH(OH)CH₃), 2.40 (1H, ddd, *J* 15Hz, *J* 8Hz, *J* 6.5Hz, 1 x CH₂CH₂CH(OH)CH₃), 2.47 (1H, ddd, *J* 15Hz, *J* 8.5Hz, *J* 6.5Hz, 1 x CH₂CH₂CH(OH)CH₃), 2.66 (1H, dd, *J* 11Hz, *J* 14Hz, 1 x CH₂(C₆H₄)OH), 2.84-2.88 (2H, m, 1 x CH₂CHCO₂H and CH₂CHCO₂H), 3.05 (1H, dd, *J* 6.5Hz, *J* 20Hz, 1 x CH₂CHCO₂H), 3.20 (1H, dd, *J* 4.5Hz, 14Hz, 1 x CH₂(C₆H₄)OH) 3.65-3.68 (1H, m, CH(OH)CH₃), 3.96 (1H, q, *J* 7Hz, NHCHCH₃), (NHCHCO₂H obscured by HOD signal) and 6.71 and 7.05 (4H, 2 x d, *J* 8.5Hz, (C₆H₄)OH); δ_C (125MHz; CDCl₃) 16.82 and 22.49 (CH(OH)CH₃ and NHCHCH₃), 32.26 (CH₂CH(OH)CH₃), 37.01, 38.69 and 42.23 (CH₂CHCO₂H, CH₂CH₂CH(OH)CH₃ and CH₂(C₆H₄)OH), 54.84, 56.73 and 58.37 (3 x NHCHCO), 67.60 (CH(OH)CH₃), 116.20 and 131.42 (aromatic CH), 129.22 and 155.27 (2 x aromatic ipso C), 169.54, 171.10 and 174.82 (CH₂CHCO₂H, NHCHCO₂H and C(O)NH) and 211.04

(C(O)CH₂CH₂CH(OH)CH₃); m/z (FAB) 463[(MK⁺, 4%), 447[(MNa⁺, 17], 425[9], 407[55], 361[14], 337[5], 309[45], 253[66], 242[17], 172[12], 155[100], 136[20], 126[14], 107[30], 99[80], 83[20], 70[30] and 55[32].

Synthesis of *ent*-(20c)

N-((1*S*, 6*S*)-6-*t*-Butyldimethylsilyloxy-1-*t*-butyloxycarbonyl-3-oxoheptyl)-*D*-alanine benzyl ester (248c)

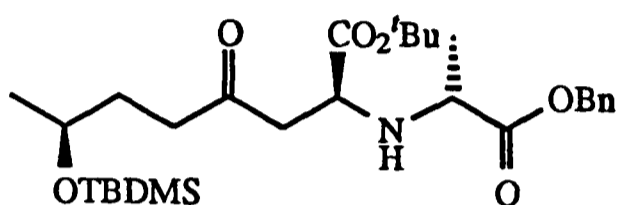

The general procedure with (2*S*, 7*S*)-*t*-butyl 2-amino-7-*t*-butyldimethylsilyloxy-4-oxo octanoate (244a) (150mg, 0.42mmol.) and (*S*)-benzyl 2-trifluoromethanesulfonyloxypropanoate (234) followed by flash chromatography (SiO₂, P.E 30-40:ether; 70:30) afforded *N*-((1*S*, 6*S*)-6-*t*-butyldimethylsilyloxy-1-*t*-butyloxycarbonyl-3-oxoheptyl)-*D*-alanine benzyl ester (248c) as a colourless oil (182mg, 83%), (R_f 0.3, P.E 30-40:ether; 70:30); [α]_D +12.2 (c 0.6 in CHCl₃); ν_{max} (FT IR, CDCl₃ solution, NaCl plates) 2957m, 2930m, 1737br s (C=O), 1470s, 1369s, 1256s, 1153s, 837s and 776m cm⁻¹; δ_H (200MHz; CDCl₃) 0.04 and 0.05 (6H, 2 x s, Si(CH₃)₂), 0.89 (9H, s, SiC(CH₃)₂), 1.12 (3H, d, *J* 6Hz, CH(OSi(CH₃)₂C(CH₃)₃)CH₃), 1.31 (3H, d, *J* 7Hz, NHCHCH₃), 1.44 (9H, s, CH₂CHCO₂C(CH₃)₃), 1.55-1.82 (2H, m, CH₂CH(OSi(CH₃)₂C(CH₃)₃)CH₃), 2.35-2.61 (2H, m, CH₂CH₂CH(OSi(CH₃)₂C(CH₃)₃)CH₃), 2.62-2.88 (2H, m, CH₂CHCO₂C(CH₃)₃), 3.50 (1H, q, *J* 7Hz, NHCHCH₃), 3.65 (1H, t, *J* 6.5Hz, CH₂CHCO₂C(CH₃)₃), 3.75-3.90 (1H, m, CH(OSi(CH₃)₂C(CH₃)₃)), 5.12 and 5.20 (2H, ABq, *J* 12.5Hz, NHCHCO₂CH₂(C₆H₅) and 7.37 (5H, s, NHCHCO₂CH₂(C₆H₅)); δ_C (50MHz; CDCl₃) -4.95 and -4.61 (Si(CH₃)₂), 17.91 (SiC(CH₃)₃), 18.64 and 23.57 (CH(OSi(CH₃)₂C(CH₃)₃)CH₃ and NHCHCH₃), 25.74 and 27.83 (CO₂C(CH₃)₃ and SiC(CH₃)₃), 32.77 (CH₂CH(OSi(CH₃)₂C(CH₃)₃)CH₃), 39.31 (CH₂CH₂CH(OSi(CH₃)₂C(CH₃)₃)CH₃), 46.05 (CH₂CHCO₂C(CH₃)₃), 55.02 and 55.90

(NHCHCH₃ and CH₂CHCO₂C(CH₃)₃), 66.56 (NHCHCO₂CH₂(C₆H₅)), 67.52 (CH(OSi(CH₃)₂C(CH₃)₃)CH₃), 81.63 (CH₂CHCO₂C(CH₃)₃), 128.31, 128.41 and 128.71 (aromatic CH), 135.96 (aromatic ipso C), 172.99 and 174.98 (CH₂CHCO₂C(CH₃)₃ and NHCHCO₂CH₂(C₆H₅)) and 208.48 (C(O)CH₂CH₂CH(OSi(CH₃)₂C(CH₃)₃)CH₃); m/z (chemical ionisation, NH₃) 522[(MH)⁺, 100%], 420[12], 288[23], 236[12], 180[48], 173[18], 108[17], 91[48] and 70[11].

N-((1*S*, 6*S*)-6-^tButyldimethylsilyloxy-1-^tbutyloxycarbonyl-3-oxoheptyl)-*D*-alanine (249c)

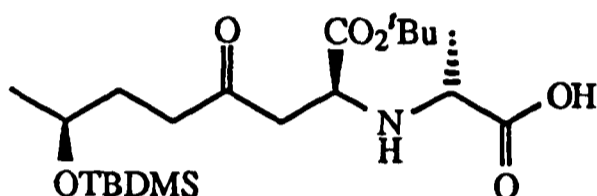

The general procedure with *N*-((1*S*, 6*S*)-6-^tbutyldimethylsilyloxy-1-^tbutyloxycarbonyl-3-oxoheptyl)-*D*-alanine benzyl ester (248c) (100mg, 0.19mmol.) afforded *N*-((1*S*, 6*S*)-6-^tbutyldimethylsilyloxy-1-^tbutyloxycarbonyl-3-oxoheptyl)-*D*-alanine (249c) as a white foam (83mg, quant.), $[\alpha]_D -0.8$ (*c* 1.0 in CHCl₃); ν_{\max} 2957m, 2897m, 1759s and 1719s (C=O), 1375s and 1157m cm⁻¹; δ_H (200MHz; CDCl₃) 0.03 (6H, s, Si(CH₃)₂), 0.87 (9H, s, SiC(CH₃)₃), 1.11 (3H, d, *J* 6Hz, CH(OSi(CH₃)₂C(CH₃)₃)CH₃), 1.38 (3H, d, *J* 7Hz, NHCHCH₃), 1.45 (9H, s, CH₂CHCO₂C(CH₃)₃), 1.60-1.80 (2H, m, CH₂CH(OSi(CH₃)₂C(CH₃)₃)CH₃), 2.32-2.65 (2H, m, CH₂CH₂CH(OSi(CH₃)₂C(CH₃)₃)CH₃), 3.02-3.20 (2H, m, CH₂CHCO₂C(CH₃)₃), 3.45 (1H, q, *J* 7Hz, NHCHCH₃), 3.72-3.98 (2H, m, CH₂CHCO₂C(CH₃)₃ and CH(OSi(CH₃)₂C(CH₃)₃)) and 6.99 (2H, br s, OH and NH); δ_C (50MHz; CDCl₃) -4.92 and -4.61 (Si(CH₃)₂), 15.96 (SiC(CH₃)₃), 17.89 and 23.53 (CH(OSi(CH₃)₂C(CH₃)₃)CH₃ and NHCHCH₃), 25.74 and 27.73 (CH₂CHCO₂C(CH₃)₃ and SiC(CH₃)₃), 32.73 (CH₂CH(OSi(CH₃)₂C(CH₃)₃)CH₃), 38.71 (CH₂CH₂CH(OSi(CH₃)₂C(CH₃)₃)CH₃), 43.37 (CH₂CHCO₂C(CH₃)₃), 54.99 and 56.53 (NHCHCH₃ and CH₂CHCO₂C(CH₃)₃), 67.49 (CH(OSi(CH₃)₂C(CH₃)₃)), 83.37 (CH₂CHCO₂C(CH₃)₃), 169.96 and 174.88 (NHCHCO₂H and CH₂CHCO₂C(CH₃)₃) and 208.01

(C(O)CH₂CH₂CH(OSi(CH₃)₂C(CH₃)₃)CH₃); m/z (chemical ionisation, NH₃) 432[(MH)⁺, 5%], 343[51], 229[28], 211[55] and 90[100].

N-((1*S*, 6*S*)-6-^tButyldimethylsilyloxy-1-^tbutyloxycarbonyl-3-oxoheptyl)-*D*-alanyl-*D*-tyrosine ^tbutylester (250c)

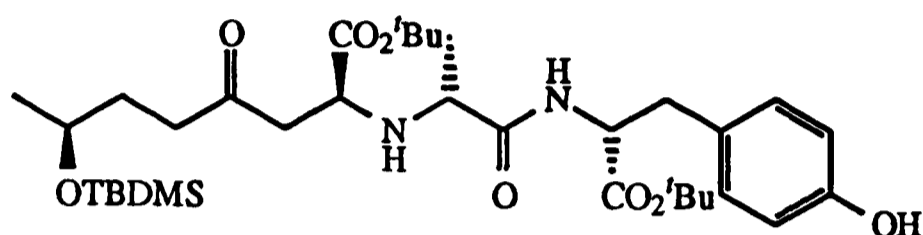

The general procedure with *N*-((1*S*, 6*S*)-6-^tbutyldimethylsilyloxy-1-^tbutyloxycarbonyl-3-oxoheptyl)-*D*-alanine (249c) (70mg, 0.16mmol.) and (*D*)-tyrosine ^tbutylester followed by flash chromatography (SiO₂, P.E. 30-40:ether; 30:70) afforded *N*-((1*S*, 6*S*)-6-^tbutyldimethylsilyloxy-1-^tbutyloxycarbonyl-3-oxoheptyl)-*D*-alanyl-*D*-tyrosine ^tbutylester (250c) as a colourless oil (84mg, 81%), (R_f 0.3, P.E 30-40:ether; 30:70); [α]_D +10.2 (c 1.0 in CHCl₃); ν_{max} (FT IR, CDCl₃ solution, NaCl plates) 2931s, 2858s, 1718s (C=O), 1462m, 1372s, 1257s, 1154s, 895s and 777m cm⁻¹; δ_H (500MHz; CDCl₃) 0.041 and 0.047 (6H, 2 x s, Si(CH₃)₂), 0.88 (9H, s, SiC(CH₃)₃), 1.10 (3H, d, *J* 7Hz, NHCHCH₃) 1.12 (3H, d, *J* 6Hz, CH(OSi(CH₃)₂C(CH₃)₃)CH₃), 1.43 (18H, s, CH₂CHCO₂C(CH₃)₃ and NHCHCO₂C(CH₃)₃), 1.59-1.80 (2H, m, CH₂CH(OSi(CH₃)₂C(CH₃)₃)CH₃), 2.42-2.61 (2H, m, CH₂CH₂CH(OSi(CH₃)₂C(CH₃)₃)CH₃), 2.76-2.91 (3H, m, CH₂CHCO₂C(CH₃)₃ and 1 x CH₂(C₆H₄)OH), 3.16-3.28 (2H, m, NHCHCH₃ and 1 x CH₂(C₆H₄)OH), 3.62 (1H, t, *J* 6Hz, CH₂CHCO₂C(CH₃)₃), 3.76-3.88 (1H, m, CH(OSi(CH₃)₂C(CH₃)₃)), 4.63-4.78 (1H, m, NHCHCH₂(C₆H₄)OH), 6.72 and 7.02 (2 x 2H, 2 x d, 2 x *J* 8.5Hz, (C₆H₄)OH) and 7.76 (1H, d, *J* 8.5Hz, NHCH(CO₂C(CH₃)₃)CH₂(C₆H₄)OH); δ_C (125MHz; CDCl₃) -4.69 and -4.41 (Si(CH₃)₂), 18.06 (SiC(CH₃)₃), 19.24 and 23.56 (CH(OSi(CH₃)₂C(CH₃)₃)CH₃ and NHCHCH₃), 25.87 (SiC(CH₃)₃), 27.96 and 28.01 (CH₂CHCO₂C(CH₃)₃ and NHCHCO₂C(CH₃)₃), 33.04 (CH₂CH(OSi(CH₃)₂C(CH₃)₃)CH₃), 37.42 and 39.31

($\text{CH}_2\text{CH}_2\text{CH}(\text{OSi}(\text{CH}_3)_2\text{C}(\text{CH}_3)_3\text{CH}_3$ and $\text{CH}_2(\text{C}_6\text{H}_4)\text{OH}$) 43.83 ($\text{CH}_2\text{CHCO}_2\text{C}(\text{CH}_3)_3$), 53.48, 55.61 and 55.86 (NHCHCH_3 , $\text{CH}_2\text{CHCO}_2\text{C}(\text{CH}_3)_3$ and $\text{CHCH}_2(\text{C}_6\text{H}_4)\text{OH}$), 67.66 ($\text{CH}(\text{OSi}(\text{CH}_3)_2\text{C}(\text{CH}_3)_3$)), 81.80 and 81.89 ($\text{NHCHCO}_2\text{C}(\text{CH}_3)_3$ and $\text{CH}_2\text{CHCO}_2\text{C}(\text{CH}_3)_3$), 115.38 and 130.46 (aromatic CH), 128.00 and 155.20 (2 x aromatic *ipso* C), 170.61, 172.24 and 174.82 ($\text{NHCHCO}_2\text{C}(\text{CH}_3)_3$, $\text{CH}_2\text{CHCO}_2\text{C}(\text{CH}_3)_3$ and $\text{CO}(\text{NH})$), 208.49 ($\text{C}(\text{O})\text{CH}_2\text{CH}_2\text{CH}(\text{OSi}(\text{CH}_3)_2\text{C}(\text{CH}_3)_3\text{CH}_3$); *m/z* (desorption chemical ionisation, NH_3) [651(MH)⁺, 15%], 343[51], 309[100], 253[89], 211[34] and 89[27].

N-((1*S*, 6*S*)-6-Hydroxy-1-carboxylic acid-3-oxoheptyl)-*D*-alanyl-*D*-tyrosine (trifluoromethane sulfonate salt) *ent*-(20c)

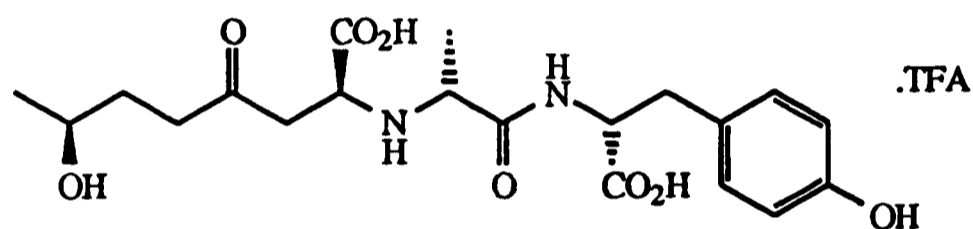

The general procedure with *N*-((1*S*, 6*S*)-6-^tbutyldimethylsilyloxy-1-^tbutyloxycarbonyl-3-oxoheptyl)-*D*-alanyl-*D*-tyrosine^tbutylester (250c) (30mg, 0.046mmol.) afforded *N*-((1*S*, 6*S*)-6-hydroxy-1-carboxylic acid-3-oxoheptyl)-*D*-alanyl-*D*-tyrosine (trifluoromethane sulfonate salt) *ent*-(20c) as a white powder (19mg, 77%), *m.p.* 92-94°C; $[\alpha]_D +6.2$ (*c* 0.37 in H_2O); ν_{max} (FT IR, KBr disc) 3382br m (NH and OH), 1780m, 1720s, 1673s, 1616s, 1559s, 1518s, 1448s, 1385s, 1350s, 1200s and 1142s cm^{-1} ; δ_{H} (500MHz; D_2O) 1.16 (3H, d, *J* 6.5Hz, $\text{CH}(\text{OH})\text{CH}_3$), 1.40 (3H, d, *J* 7Hz, NHCHCH_3), 1.62-1.75 (2H, m, $\text{CH}_2\text{CH}(\text{OH})\text{CH}_3$), 2.45-2.52 (2H, m, $\text{CH}_2\text{CH}_2\text{CH}(\text{OH})\text{CH}_3$), 2.66 (1H, dd, *J* 10.5Hz, *J* 14Hz, 1 x $\text{CH}_2(\text{C}_6\text{H}_4)\text{OH}$), 3.04-3.89 (3H, m, $\text{CH}_2\text{CHCO}_2\text{H}$ and $\text{CH}_2\text{CHCO}_2\text{H}$), 3.25 (1H, dd, *J* 5Hz, 14Hz, 1 x $\text{CH}_2(\text{C}_6\text{H}_4)\text{OH}$) 3.78-3.82 (1H, m, $\text{CH}(\text{OH})\text{CH}_3$), 4.06 (1H, q, *J* 7Hz, NHCHCH_3), (NHCHCO_2H obscured by HOD signal) and 6.84 and 7.16 (4H, 2 x d, *J* 8.5Hz, $(\text{C}_6\text{H}_4)\text{OH}$); δ_{C} (125MHz; CDCl_3) 16.02 and 22.50 ($\text{CH}(\text{OH})\text{CH}_3$ and NHCHCH_3), 32.26 ($\text{CH}_2\text{CH}(\text{OH})\text{CH}_3$), 36.21, 38.79 and 40.95 ($\text{CH}_2\text{CHCO}_2\text{H}$, $\text{CH}_2\text{CH}_2\text{CH}(\text{OH})\text{CH}_3$ and $\text{CH}_2(\text{C}_6\text{H}_4)\text{OH}$), 54.85 and 56.00 (3 x

NHCHCO), 66.92 (CH(OH)CH₃), 115.90 and 130.87 (aromatic CH), 128.61 and 154.95 (2 x aromatic ipso C), 169.57, 170.93 and 174.53 (CH₂CHCO₂H, NHCHCO₂H and C(O)NH) and 210.96 (C(O)CH₂CH₂CH(OH)CH₃); m/z (negative ion electrospray) 423[(M-H⁻), 100%].

Synthesis of ent-(20d)

N-((1*S*, 6*R*)-6-^tButyldimethylsilyloxy-1-^tbutyloxycarbonyl-3-oxoheptyl)-*D*-alanine benzyl ester (248d)

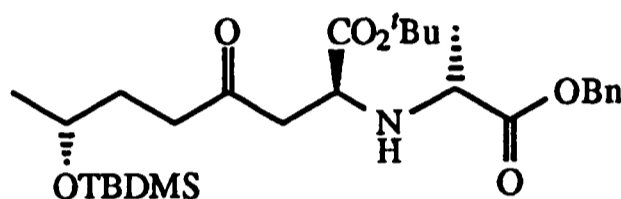

The general procedure with (2*S*, 7*R*)-^tbutyl 2-amino-7-^tbutyldimethylsilyloxy-4-oxo octanoate (244b) (160mg, 0.45mmol.) and (*S*)-benzyl 2-trifluoromethanesulfonyloxypropanoate (234) followed by flash chromatography (SiO₂, P.E 30-40:ether; 70:30) afforded *N*-((1*S*, 6*R*)-6-^tbutyldimethylsilyloxy-1-^tbutyloxycarbonyl-3-oxoheptyl)-*D*-alanine benzyl ester (248d) as a colourless oil (192mg, 82%), (R_f 0.3, P.E 30-40:ether; 70:30); [α]_D -4.1 (c 0.7 in CHCl₃); ν_{max} (FT IR, CDCl₃ solution, NaCl plates) 2957m, 2930m, 2895m, 2857m, 1737br s (C=O), 1473s, 1456m, 1152s, 1063s, 837s and 776s cm⁻¹; δ_H (200MHz; CDCl₃) 0.03 and 0.04 (6H, 2 x s, Si(CH₃)₂), 0.88 (9H, s, SiC(CH₃)₂), 1.12 (3H, d, *J* 6Hz, CH(OSi(CH₃)₂C(CH₃)₃)CH₃), 1.29 (3H, d, *J* 7Hz, NHCHCH₃), 1.43 (9H, s, CH₂CHCO₂C(CH₃)₃), 1.55-1.80 (2H, m, CH₂CH(OSi(CH₃)₂C(CH₃)₃)CH₃), 2.32-2.65 (2H, m, CH₂CHCO₂C(CH₃)₃), 2.70-2.88 (2H, m, CH₂CHCO₂C(CH₃)₃), 3.46 (1H, q, *J* 7Hz, NHCHCH₃), 3.63 (1H, t, *J* 6Hz, CH₂CHCO₂C(CH₃)₃), 3.73-3.89 (1H, m, CH(OSi(CH₃)₂C(CH₃)₃)), 5.10 and 5.18 (2H, ABq, *J* 12.5Hz, NHCHCO₂CH₂(C₆H₅)) and 7.35 (5H, s, NHCHCO₂CH₂(C₆H₅)); m/z (chemical ionisation, NH₃) 522[(MH)⁺, 100%], 420[12], 288[30], 180[20] and 91[32].

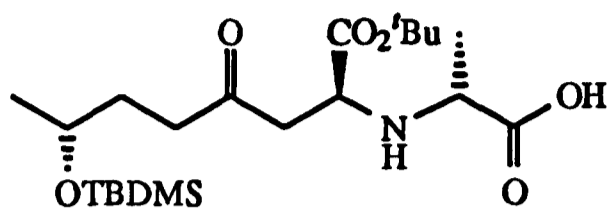
N-((1*S*, 6*R*)-6-^tButyldimethylsilyloxy-1-^tbutyloxycarbonyl-3-oxoheptyl)-*D*-alanine (249d)

The general procedure with *N*-((1*S*, 6*R*)-6-^tbutyldimethylsilyloxy-1-^tbutyloxycarbonyl-3-oxoheptyl)-*D*-alanine benzyl ester (248d) (120mg, 0.23mmol.) afforded *N*-((1*S*, 6*R*)-6-^tbutyldimethylsilyloxy-1-^tbutyloxycarbonyl-3-oxoheptyl)-*D*-alanine (249d) as a white foam (99mg, quant.), *m/z* (high resolution) Found 432.2781, C₂₁H₄₁NO₆Si+H⁺ requires 432.2781; [α]_D -25.64 (*c* 0.85 in CHCl₃); ν_{max} 2958m, 1754s and 1719s (C=O), 1372s, 1257m, 1157m cm⁻¹; δ_H (200MHz; CDCl₃) 0.04 and 0.05 (6H, 2 x s, Si(CH₃)₂), 0.89 (9H, s, SiC(CH₃)₃), 1.13 (3H, d, *J* 6Hz, CH(OSi(CH₃)₂C(CH₃)₃)CH₃), 1.42 (3H, d, *J* 7Hz, NHCHCH₃), 1.46 (9H, s, CH₂CHCO₂C(CH₃)₃), 1.50-1.82 (2H, m, CH₂CH(OSi(CH₃)₂C(CH₃)₃)CH₃), 2.53 (2H, t, *J* 7.5Hz, CH₂CH₂CH(OSi(CH₃)₂C(CH₃)₃)CH₃), 2.85-2.97 (2H, m, CH₂CHCO₂C(CH₃)₃), 3.39 (1H, q, *J* 7Hz, NHCHCH₃), 3.68-3.90 (2H, m, CH(OSi(CH₃)₂C(CH₃)₃) and CH₂CHCO₂C(CH₃)₃); *m/z* (chemical ionisation, NH₃) 432[(MH)⁺, 33%], 343[55], 211[15] and 90[100].

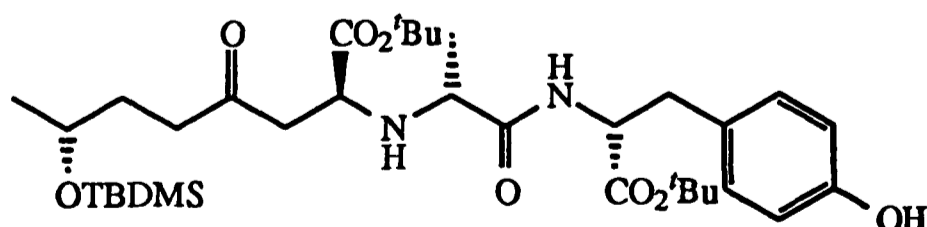
N-((1*S*, 6*R*)-6-^tButyldimethylsilyloxy-1-^tbutyloxycarbonyl-3-oxoheptyl)-*D*-alanyl-*D*-tyrosine ^tbutylester (250d)

The general procedure with *N*-((6*R*)-6-^tbutyldimethylsilyloxy-1-^tbutyloxycarbonyl-3-oxoheptyl)-*D*-alanine (249d) (70mg, 0.16mmol.) and (*D*)-tyrosine ^tbutylester followed by flash chromatography (SiO₂, P.E. 30-40:ether; 30:70) afforded *N*-((1*S*, 6*R*)-6-

t-butyldimethylsilyloxy-1-*t*-butyloxycarbonyl-3-oxoheptyl)-*D*-alanyl-*D*-tyrosine-*t*-butylester (250d) as a colourless oil (83mg, 80%), (R_f 0.3, P.E 30-40:ether; 30:70); $[\alpha]_D$ -19.2 (c 0.6 in CHCl_3); ν_{max} (FT IR, CDCl_3 solution, NaCl plates) 2932m, 1724s (C=O), 1661s, 1516s, 1371s, 1256s, 1156s, 923s and 839s cm^{-1} ; δ_{H} (500MHz; CDCl_3) 0.00, 0.04 and 0.05 (6H, 3 x s, $\text{Si}(\text{CH}_3)_2$), 0.88 (9H, s, $\text{SiC}(\text{CH}_3)_3$), 1.10 (3H, d, J 7Hz, NHCHCH_3) 1.12 (3H, d, J 6Hz, $\text{CH}(\text{OSi}(\text{CH}_3)_2\text{C}(\text{CH}_3)_3)\text{CH}_3$), 1.43 (18H, s, $\text{CH}_2\text{CHCO}_2\text{C}(\text{CH}_3)_3$ and $\text{NHCHCO}_2\text{C}(\text{CH}_3)_3$), 1.59-1.75 (2H, m, $\text{CH}_2\text{CH}(\text{OSi}(\text{CH}_3)_2\text{C}(\text{CH}_3)_3)\text{CH}_3$), 2.48 (2H, m, $\text{CH}_2\text{CH}_2\text{CH}(\text{OSi}(\text{CH}_3)_2\text{C}(\text{CH}_3)_3)\text{CH}_3$), 2.77 (2H, m, $\text{CH}_2\text{CHCO}_2\text{C}(\text{CH}_3)_3$), 2.86 (1H, dd, J 8Hz, J 14Hz, $\text{CH}_2(\text{C}_6\text{H}_4)\text{OH}$), 3.10 (1H, dd, J 5.5Hz, J 14Hz, 1 x $\text{CH}_2(\text{C}_6\text{H}_4)\text{OH}$), 3.21 (1H, q, J 7Hz, NHCHCH_3), 3.61 (1H, t, J 6Hz, $\text{CH}_2\text{CHCO}_2\text{C}(\text{CH}_3)_3$), 3.82 (1H, m, $\text{CH}(\text{OSi}(\text{CH}_3)_2\text{C}(\text{CH}_3)_3)$), 4.67 (1H, m, $\text{NHCHCH}_2(\text{C}_6\text{H}_4)\text{OH}$), 6.72 and 7.01 (2 x 2H, 2 x d, 2 x J 8.5Hz, $(\text{C}_6\text{H}_4)\text{OH}$) and 7.77 (1H, d, J 8.5Hz, $\text{NHCH}(\text{CO}_2\text{C}(\text{CH}_3)_3)\text{CH}_2(\text{C}_6\text{H}_4)\text{OH}$); δ_{C} (125MHz; CDCl_3) -4.72 and -4.41 ($\text{Si}(\text{CH}_3)_2$), 18.05 ($\text{SiC}(\text{CH}_3)_3$), 19.26 and 23.60 ($\text{CH}(\text{OSi}(\text{CH}_3)_2\text{C}(\text{CH}_3)_3)\text{CH}_3$ and NHCHCH_3), 25.87 ($\text{SiC}(\text{CH}_3)_3$), 27.94 and 27.99 ($\text{CH}_2\text{CHCO}_2\text{C}(\text{CH}_3)_3$ and $\text{NHCHCO}_2\text{C}(\text{CH}_3)_3$), 32.98 ($\text{CH}_2\text{CH}(\text{OSi}(\text{CH}_3)_2\text{C}(\text{CH}_3)_3)\text{CH}_3$), 37.44 and 39.21 ($\text{CH}_2\text{CH}_2\text{CH}(\text{OSi}(\text{CH}_3)_2\text{C}(\text{CH}_3)_3)\text{CH}_3$ and $\text{CH}_2(\text{C}_6\text{H}_4)\text{OH}$) 43.68 $\text{CH}_2\text{CHCO}_2\text{C}(\text{CH}_3)_3$, 53.50, 56.60 and 55.87 (NHCHCH_3 , $\text{CH}_2\text{CHCO}_2\text{C}(\text{CH}_3)_3$ and $\text{CHCH}_2(\text{C}_6\text{H}_4)\text{OH}$), 67.55 ($\text{CH}(\text{OSi}(\text{CH}_3)_2\text{C}(\text{CH}_3)_3)$), 81.80 and 81.89 ($\text{NHCHCO}_2\text{C}(\text{CH}_3)_3$ and $\text{CH}_2\text{CHCO}_2\text{C}(\text{CH}_3)_3$), 115.37 and 130.41 (aromatic CH), 127.85 and 155.32 (2 x aromatic *ipso* C), 170.63, 172.26 and 174.97 ($\text{NHCHCO}_2\text{C}(\text{CH}_3)_3$, $\text{CH}_2\text{CHCO}_2\text{C}(\text{CH}_3)_3$) and $\text{CO}(\text{NH})$) and 208.64 ($\text{C}(\text{O})\text{CH}_2\text{CH}_2\text{CH}(\text{OSi}(\text{CH}_3)_2\text{C}(\text{CH}_3)_3)\text{CH}_3$); m/z (desorption chemical ionisation, NH_3) [651(MH) $^+$, 10%], 617[10], 343[40], 309[100], 253[90], 229[20], 211[30] and 89[25].

N-((1*S*, 6*R*)-6-Hydroxy-1-carboxylic acid-3-oxoheptyl)-*D*-alanyl-*D*-tyrosine
(trifluoromethane sulfonate salt) (*ent*-(20d))

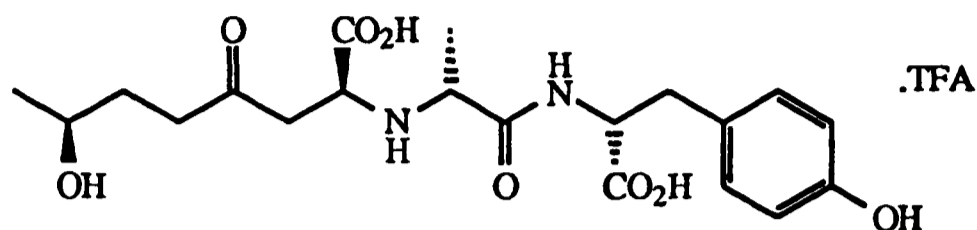

The general procedure with *N*-((1*S*, 6*R*)-6-*t*-butyldimethylsilyloxy-1-*t*-butyloxycarbonyl-3-oxoheptyl)-*D*-alanyl-*D*-tyrosine *t*-butylester (250d) (30mg, 0.046mmol.) afforded *N*-((1*S*, 6*R*)-6-hydroxy-1-carboxylic acid-3-oxoheptyl)-*D*-alanyl-*D*-tyrosine (trifluoromethane sulfonate salt) (*ent*-(20d)) as a white powder, (19mg, 77%), m.p. 89-91°C; $[\alpha]_D +2.5$ (*c* 0.37 in H₂O); ν_{\max} (FT IR, KBr disc) 3400br m (NH and OH), 1775s, 1719s, 1673s, 1518s, 1448s, 1384s, 1201s and 1141s cm⁻¹; δ_H (500MHz; D₂O) 1.05 (3H, d, *J* 6.5Hz, CH(OH)CH₃), 1.43 (3H, d, *J* 7Hz, NHCHCH₃), 1.52-1.65 (2H, m, CH₂CH(OH)CH₃), 2.35-2.99 (2H, m, CH₂CH₂CH(OH)CH₃), 2.79 (1H, dd, *J* 10Hz, *J* 14Hz, 1 x CH₂(C₆H₄)OH), 2.85-2.98 (3H, m, CH₂CHCO₂H and CH₂CHCO₂H), 3.20 (2H, dd, *J* 4.5Hz, 14Hz, 1 x CH₂(C₆H₄)OH) 3.65-3.68 (1H, m, CH(OH)CH₃), 3.94 (1H, q, *J* 7Hz, NHCHCH₃), (NHCHCO₂H obscured by HOD signal) and 6.74 and 7.06 (4H, 2 x d, *J* 8.5Hz, (C₆H₄)OH); δ_C (125MHz; CDCl₃) 16.17 and 22.20 (CH(OH)CH₃ and NHCHCH₃), 31.96 (CH₂CH(OH)CH₃), 36.15, 38.68 and 40.77 (CH₂CHCO₂H, CH₂CH₂CH(OH)CH₃ and CH₂(C₆H₄)OH), 49.30, 54.82, 55.83 (3 x NHCHCO), 67.30 (CH(OH)CH₃), 115.97 and 130.93 (aromatic CH), 128.84 and 154.97 (2 x aromatic ipso C), 169.75, 171.50 and 174.76 (CH₂CHCO₂H, NHCHCO₂H and C(O)NH) and 211.05 (C(O)CH₂CH₂CH(OH)CH₃); *m/z* (negative ion electrospray) 423[(M-H)⁻, 100%].

N-((1*S*, 6*S*)-6-acetoxy-1-methyloxycarbonyl-3-oxoheptyl)-*L*-alanyl-*L*-(4'-acetoxyphenyl) alaninemethylester (256)¹⁵

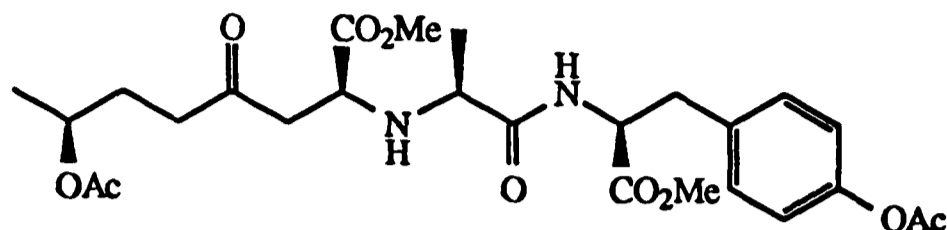

To a stirred solution of *N*-((1*S*, 6*S*)-6-hydroxy-1-carboxylic acid-3-oxoheptyl)-*L*-alanyl-*L*-tyrosine (trifluoromethane sulfonate salt) (20a) (10mg, 0.019mmol.) in distilled methanol (5ml) cooled to 0°C was added a solution of diazomethane (*ca.* 2ml) in ether (10ml) until the colour just persisted. The mixture was stirred for a further 10 minutes and then concentrated *in vacuo* to afford a yellow oil. To a stirred solution of this crude reaction mixture (which contained predominantly *N*-(6*S*)-6-hydroxy-1-methyloxycarbonyl-3-oxoheptyl)-*L*-alanine-*L*-tyrosine methyl ester (255)) in anhydrous pyridine (1ml) under an inert atmosphere of argon was added acetic anhydride (500μl, 5.3mmol.). The mixture was stirred at room temperature for twenty hours before being concentrated *in vacuo* to yield a yellow oil. Flash chromatography (SiO₂, ether:ethylacetate; 70:30) afforded *N*-(6*S*)-6-acetoxy-1-methyloxycarbonyl-3-oxoheptyl)-*L*-alanine-*L*-(4'-acetoxyphenyl)alanine methylester (256) as a colourless oil (3mg, 30%); δ_H (200MHz; CDCl₃) 1.22 (6H, 2 x d, 2 x *J* 6Hz, CH(OCOCH₃)CH₃ and NHCHCH₃), 1.70-1.90 (2H, m, CH₂CH(OCOCH₃)CH₃), 2.03 and 2.29 (2 x 3H, 2 x s, 2 x OCOCH₃), 2.38-2.50 (2H, m, CH₂CH₂CH(OCOCH₃)CH₃), 2.79 (2H, d, *J* 5.5Hz, CH₂CHCO₂CH₃), 3.15-3.27 (3H, m, CH₂(C₆H₄)OH and CH₂CHCO₂CH₃), 3.55 (1H, t, *J* 6Hz, NHCHCH₃), 3.70 and 3.75 (2 x 3H, 2 x s, 2 x CO₂CH₃), 4.72-4.93 (1H, m, CH(OCOCH₃)CH₃ and NHCHCH₂), 7.00 and 7.17 (2 x 2H, 2 x d, 2 x *J* 8.5Hz, (C₆H₄)OCOCH₃) and 7.93 (1H, d, *J* 8Hz, NHCHCO₂CH₃).

Chapter 12

References for Part II

1. C.J. Suckling, *Enzyme Chemistry*, Chapman and Hall, London, 1984, p.146-149.
2. M.J. Wyvratt and A.A. Patchett, *Med. Res. Rev.*, 1985, 5, 483.
3. R.B. Silverman, *The Organic Chemistry of Drug Design and Drug Action*, Academic Press, San Diego, 1992.
4. S.H. Ferreira, *Br. J. Pharmac.*, 1965, 24, 163.
5. M.A. Ondetti, N.J. Williams, E.F. Sabo, J. Pluscec, E.R. Weaver and O. Kocy, *Eur. J. Pharmac.*, 1971, 46, 207.
6. M.A. Ondetti and D.W. Cushman, *Biochemical Regulation of Blood Pressure*, Wiley, New York, 1981.
7. M. Das and R.L. Soffer, *J. Biol. Chem.*, 1975, 250, 6762.
8. F.A. Quioco and W.N. Lipscomb, *Adv. Protein Chem.*, 1971, 25, 1.
9. L.D. Byers and R. Wolfenden, *Biochemistry*, 1973, 12, 2070.
10. D.W. Cushman, H.S. Cheung, E.F. Sabo and M.A. Ondetti, *Biochemistry*, 1977, 16, 5484.
11. M.A. Ondetti, D.W. Cushman, E.F. Sabo and H.S. Cheung, *Drug Action and Design: Mechanism-Based Enzyme Inhibitors*, Elsevier/North-Holland, New York, 1979, p.271.
12. A.A. Patchett, E. Harris, E.W. Tristram, M.J. Wyvratt, M.T. Wu, D. Taub, E.R. Peterson, T.J. Ikeler, J. ten Broeke, L.G. Payne, D.L. Ondeyka, E.D. Thorsett, W.J. Greenlee, N.S. Lohr, R.D. Hoffsommer, H. Joshua, W.V. Ruyle, J.W. Rothrock, S.D. Aster, A.L. Maycock, F.M. Robinson, R. Hirschmann, C.S. Sweet, E.H. Ulm, D.M. Gross, T.C. Vassil and C.A. Stone, *Nature, London*, 1980, 288, 280.
13. D.S. Karanewsky, M.C. Badia, D.W. Cushman, J.M. DeForrest, T. Dejneka, M.J. Loots, M.G. Perri, E.W. Petrillo and J.R. Powell, *J. Med. Chem.*, 1988, 31, 204.
14. S. Umezawa, K. Tatsuta, O. Izawa and T. Tsuchiya, *Tetrahedron Lett.*, 1972, 97.

15. T. Ando, S. Okada, I. Uchida, K. Hemmi, M. Nishikawa, Y. Tsurumi, A. Fujie, K. Yoshida and M. Okuhara, *J. Antibiot.*, 1987, **40**, 468.
16. M.J. Wyvratt, E.W. Tristram, T.J. Ikeler, N.S. Lohr, H. Joshua, J.P. Springer, B.H. Arison and A.A. Patchett, *J. Org. Chem.*, 1984, **49**, 2816.
17. H. Urbach and R. Henning, *Tetrahedron Lett.*, 1984, **25**, 1143.
18. A. Arcadi, E. Bernocchi, S. Cacchi, F. Marinelli and A. Scarinci, *Synlett*, 1991, 177.
19. R. Escher and P. Bünning, *Angew. Chem. Int. Ed. Engl.*, 1986, **25**, 277.
20. G.A. Flynn and D.W. Beight, *Tetrahedron Lett.*, 1988, **29**, 423.
21. G.C. Barrett, *Chemistry and Biochemistry of the Amino Acids*, Chapman and Hall, London, 1985.
22. R.M. Williams, *Synthesis of Optically Pure α -Amino Acids*, Pergamon Press, London, 1989.
23. R.B. Herbert, *The Biosynthesis of Secondary Metabolites*, Chapman and Hall, London, 1989.
24. J. Crosby, *Tetrahedron*, 1991, **47**, 4789.
25. T.W. Stone and J.H. Connick, *Neuroscience*, 1985, **15**, 597.
26. M.F. Beal, N.W. Kowall, D.W. Ellison, M.F. Mazurek, K.J. Schwartz and J.B. Martin, *Nature*, 1986, **321**, 168.
27. S. Mazzari, C. Aldinio, M. Beccaro, G. Toffano and R. Schwartz, *Brain Res.*, 1986, **380**, 309.
28. K.-I. Kanazawa, K. Tsuchiya and T. Araki, *Am. Rev. Respirat. Diseases*, 1960, **81**, 924.
29. A. Mikaye, *Chem. Pharm. Bull.*, 1960, **8**, 1071.
30. A. Mikaye, *Chem. Pharm. Bull.*, 1960, **8**, 1074.
31. H. Yamaguchi, K. Uchida, T. Hiratani, T. Nagate, N. Watanabe and S. Omura, *Ann. N. Y. Acad. Sci.*, 1988, **544**, 188.
32. M. Yamaguchi, H. Yamaki, T. Shinoda, Y. Tago, H. Suzuki, T. Nishimura and H. Yamaguchi, *J. Antibiot.*, 1990, **43**, 411.
33. H. Yamaki, M. Yamaguchi, T. Nishimura, T. Shinoda and H. Yamaguchi, *Exptl. Clin. Res.*, 1988, **14**, 467.

34. H. Yamaki, M. Yamaguchi, H. Imamura, H. Suzuki, T. Nishimura, H. Saito and H. Yamaguchi, *Biochem. Biophys. Res. Comm.*, 1990, **168**, 837.
35. R.L. White, A.C. DeMarco and K.C. Smith, *J. Am. Chem. Soc.*, 1988, **110**, 8228.
36. C.G. Hirth, M. Véron, C. Villar-Palasi, N. Hurion and G.N. Cohen, *Eur. J. Biochem.*, 1975, **50**, 425.
37. R. Sekura and A. Meister, *J. Biol. Chem.*, 1977, **252**, 2606.
38. R.A. Shapiro, V.M. Clark and N.P. Curthoys, *J. Biol. Chem.*, 1978, **253**, 7086.
39. A. Ichihara, H. Hasegawa, H. Sato, M. Koyama and S. Sakamura, *Tetrahedron Lett.*, 1973, 37.
40. G.T. Barry and E. Roark, *J. Biol. Chem.*, 1964, **239**, 1541.
41. H. Faulstich, J. Dölling, K. Michl and T. Wieland, *Liebigs Ann. Chem.*, 1973, 560.
42. H.H. Mooiweer, K.W.A. Ettema, H. Hiemstra and W.N. Speckamp, *Tetrahedron*, 1990, **46**, 2991.
43. E.C. Roos, M.C. López, M.A. Brook, H. Hiemstra, W.N. Speckamp, B. Kaptein, J. Kamphuis and H.E. Schoemaker, *J. Org. Chem.*, 1993, **58**, 3259.
44. D. Ben-Ishai, J. Altman, Z. Bernstein and N. Peled, *Tetrahedron*, 1978, **34**, 467.
45. J.P. Whitten, C.L. Barney, E.W. Huber, P. Bey and J.R. McCarthy, *Tetrahedron Lett.*, 1989, **30**, 3649.
46. O. Achmatowicz and M. Pietraszkiewicz, *Tetrahedron Lett.*, 1981, **22**, 4323.
47. R. Kober, K. Papadopoulos, W. Miltz, D. Enders, W. Steglich, H. Reuter and H. Puff, *Tetrahedron*, 1985, **41**, 1693.
48. U. Schmidt, F. Stäbler and A. Lieberknecht, *Synthesis*, 1992, 482.
49. N. Aubry, R. Plante and R. Déziel, *Tetrahedron Lett.*, 1990, **31**, 6311.
50. H.V. Wheal and A.M. Thomson, *Excitatory Amino Acids and Synaptic Transmission*, Academic Press, London, 1991, p.1-17.
51. C.W. Cotman and L.L. Iversen, *Trends Neurosci.*, 1987, **10**, 263.
52. J.P. Whitten, B.M. Baron, D. Muench, F. Miller, H.S. White and I.A. McDonald, *J. Med. Chem.*, 1990, **33**, 2961.
53. D.E. Rudisill and J.P. Whitten, *Synthesis*, 1994, 851.
54. C.W. Holzapfel and J. Olivier, *Syn. Commun.*, 1993, **23**, 2511.

55. D.G. Melillo, R.D. Larsen, D.J. Mathre, W.F. Shukis and A.W. Wood, *J. Org. Chem.*, 1987, **52**, 5143.
56. M. Bodanszky and A. Bodanszky, *The Practice of Peptide Synthesis*, Springer Verlag, Berlin, 1984, p.14.
57. K. Burger, M. Rudolph and H. Neuhauser, *Liebigs Ann. Chem.*, 1991, 1365.
58. K. Burger, M. Rudolph and S. Fehn, *Angew. Chem. Int. Ed. Engl.*, 1993, **32**, 285.
59. J.L. Warnell and C.P. Berg, *J. Am. Chem. Soc.*, 1954, **76**, 1708.
60. C.E. Dalglish, *J. Chem. Soc.*, 1952, 137.
61. T. Nagasaka and S. Ohki, *Chem. Pharm. Bull.*, 1971, **19**, 603.
62. F. Sakiyama, N. Masuda, T. Nakazawa and Y. Katsuragi, *Chem. Lett.*, 1978, 893.
63. S. Ranganathan, D. Ranganathan, S. Singh and D. Bhattacharyya, *J. Chem. Soc., Chem. Commun.*, 1987, 1887.
64. F.G. Salituro and I.A. McDonald, *J. Org. Chem.*, 1988, **53**, 6138.
65. R.F.W. Jackson, A. Wood and M.J. Wythes, *Synlett*, 1990, 735.
66. R.F.W. Jackson, N. Wishart, A. Wood, K. James and M.J. Wythes, *J. Org. Chem.*, 1992, **57**, 3397.
67. H. Staudinger, *Justus Liebigs Ann. Chem.*, 1907, **356**, 51.
68. E.P. Abraham, *History of the β -Lactam Antibiotics in Antibiotics Containing the β -Lactam Structure, Part I*, Springer-Verlag, Berlin, 1983, p.1-13.
69. R. Labia and C. Morin, *Chem. Lett.*, 1984, 1007.
70. J.S. Sandhu and B. Sain, *Heterocycles*, 1987, **26**, 777.
71. L.S. Hegedus, R. Imwinkelried, M. Alarid-Sargent, D. Dvorak and Y. Satoh, *J. Am. Chem. Soc.*, 1990, **112**, 1109.
72. D.J. Hart and D.-C. Ha, *Chem. Rev.*, 1989, **89**, 1447.
73. M.J. Brown, *Heterocycles*, 1989, **29**, 2225.
74. S.G. Davies, *Organotransition Metal Chemistry; Application to Organic Synthesis*, Pergamon Press, Oxford, 1983.
75. M.S. Manhas, S.G. Amin and A.K. Bose, *Heterocycles*, 1976, **5**, (669).
76. M.S. Manhas, D.R. Wagle, J. Chiang and A.K. Bose, *Heterocycles*, 1988, **27**, 1755.
77. G. Georg, *The Organic Chemistry of β -Lactams*, VCH Publishers Inc., New York, 1992, p.197-255.

78. C. Palamo, J.M. Aizpurua, I. Ganboa, F. Carreaux, C. Cuevas, E. Maneiro and J.M. Ontoria, *J. Org. Chem.*, 1994, **59**, 3123.
79. J.H. Bateson, S.C.M. Fell, A.C. Kaura and R. Southgate, *J. Chem. Soc., Perkin Trans. I*, 1992, 1577.
80. A.K. Bose and I. Kugajevsky, *Tetrahedron*, 1967, **23**, 957.
81. B. Alcaide, Y. Martín-Cantalejo, J. Rodríguez-López and M.A. Sierra, *J. Org. Chem.*, 1993, **58**, 4767.
82. Ojima, H.-J.C. Chen and X. Qiu, *Tetrahedron*, 1988, **44**, 5307.
83. I. Ojima, I. Habus, M. Zhao, M. Zucco, Y.H. Park, C.M. Sun and T. Brigaud, *Tetrahedron*, 1992, **48**, 6985.
84. R.A. Holton, H.-B. Kim, C. Somoza, F. Liang, R.J. Biediger, P.D. Boatman, M. Shindo, C.C. Smith, S. Kim, H. Nadizadeh, Y. Suzuki, C. Tao, P. Vu, S. Tang, P. Zhang, K.K. Murthi, L.N. Gentile and J.H. Liu, *J. Am. Chem. Soc.*, 1994, **116**, 1599.
85. K.C. Nicolaou, Z. Yang, J.J. Liu, H. Ueno, P.G. Nantermet, R.K. Guy, C.F. Claiborne, J. Renaud, E.A. Couladouros, K. Paulvannan and E.J. Sorensen, *Nature*, 1994, **367**, 630.
86. K.C. Nicolaou, W.-M. Dai and R.K. Guy, *Angew. Chem. Int. Ed. Engl.*, 1994, **33**, 15.
87. R.A. Holton, *EP-A 400971*, 1990.
88. I. Ojima, C.M. Sun, M. Zucco, Y.H. Park, O. Duclos and S. Kuduk, *Tetrahedron Lett.*, 1993, **34**, 4149.
89. J.E. Baldwin, A.J. Edwards, C.N. Farthing and A.T. Russell, *Synlett*, 1993, 49.
90. J.E. Baldwin, R.M. Adlington and D.J. Birch, *J. Chem. Soc., Chem. Commun.*, 1985, 256.
91. S.D. Broady, J.E. Rexhausen and E.J. Thomas, *J. Chem. Soc., Chem. Commun.*, 1991, 708.
92. J.M. Roe and E.J. Thomas, *Synlett*, 1990, 727.
93. J.E. Baldwin, R.M. Adlington, C.R.A. Godfrey, D.W. Gollins, M.L. Smith and A.T. Russell, *Synlett*, 1993, 51.
94. D.W. Gollins, D. Phil. Thesis, Oxford, 1992.

95. L. Zervas, M. Winitz and J.P. Greenstein, *J. Org. Chem.*, 1957, **22**, 1515.
96. T.N. Salzman, R.W. Ratcliffe, B.G. Christensen and F.A. Bouffard, *J. Am. Chem. Soc.*, 1980, **102**, 6161.
97. L. Birkofer and J. Schramm, *Liebigs Ann. Chem.*, 1975, 2195.
98. J.E. Baldwin, R.M. Adlington, D.W. Gollins and C.J. Schofield, *Tetrahedron*, 1990, **46**, 4733.
99. B.M. Trost, *J. Am. Chem. Soc.*, 1967, **89**, 138.
100. H. Nozaki, M. Takaku and K. Kondô, *Tetrahedron*, 1966, **22**, 2145.
101. R.M. Adams and C.A. Vanderwerf, *J. Am. Chem. Soc.*, 1950, **72**, 4368.
102. K. Okuma, Y. Tanaka, S. Kaji and H. Ohta, *J. Org. Chem.*, 1983, **48**, 5133.
103. N.K. Sharma, F. de Reinach-Hirtzbach and T. Durst, *Can. J. Chem.*, 1976, **54**, 3012.
104. Y. Gao and K.B. Sharpless, *J. Am. Chem. Soc.*, 1988, **110**, 7538.
105. M.S. Berridge, M.P. Franceschini, E. Rosenfeld and T.J. Tewson, *J. Org. Chem.*, 1990, **55**, 1211.
106. B.B. Lohray, *Synthesis*, 1992, 1035.
107. B.M. Kim and K.B. Sharpless, *Tetrahedron Lett.*, 1989, **30**, 655.
108. B.B. Lohray, Y. Gao and K.B. Sharpless, *Tetrahedron Lett.*, 1989, **30**, 2623.
109. B.M. Trost and D.P. Curran, *Tetrahedron Lett.*, 1981, **22**, 1287.
110. P.D. Magnus, *Tetrahedron*, 1977, **33**, 2019.
111. E.J. Corey and M. Chaykovsky, *J. Am. Chem. Soc.*, 1964, **86**, 1639.
112. E.J. Corey and M. Chaykovsky, *J. Am. Chem. Soc.*, 1965, **87**, 1345.
113. A.B. Smith III, K.J. Hale and J.P. McCauley Jr., *Tetrahedron Lett.*, 1989, **30**, 5579.
114. A. Armstrong, I. Brackenridge, R.F.W. Jackson and J.M. Kirk, *Tetrahedron Lett.*, 1988, **29**, 2483.
115. J.H. Babler, *J. Org. Chem.*, 1987, **52**, 4614.
116. For an analogous selective deprotection see J.E. Baldwin, R.M. Adlington, C.R.A. Godfrey, D.W. Gollins and C.J. Schofield, *Tetrahedron*, 1991, **47**, 5835.
117. S. Hanessian and P. Lavallee, *Can. J. Chem.*, 1975, **53**, 2975.
118. G. Sennyey, G. Barcelo and J.-P. Senet, *Tetrahedron Lett.*, 1986, **27**, 5375.
119. D.M. Walker, unpublished results, University of Oxford.
120. D.E. Ward and C.K. Rhee, *Tetrahedron Lett.*, 1991, **32**, 7165.

121. J. Ezquerro, J. de Mendoza, C. Pedregal and C. Ramírez, *Tetrahedron Lett.*, 1992, **33**, 5589.
122. J.A. Dale, D.L. Dull and H.S. Mosher, *J. Org. Chem.*, 1969, **34**, 2543.
123. B.H. Lipshutz, D.A. Parker, J.A. Kozlowski and R.D. Miller, *J. Org. Chem.*, 1983, **48**, 3334.
124. B.H. Lipshutz, M. Koerner and D.A. Parker, *Tetrahedron Lett.*, 1987, **28**, 945.
125. R.S. Coleman and A.J. Carpenter, *Tetrahedron Lett.*, 1992, **33**, 1697.
126. E. Vedejs, D.A. Engler and M.J. Mullins, *J. Org. Chem.*, 1977, **42**, 3109.
127. E.J. Corey and A. Venkateswarlu, *J. Am. Chem. Soc.*, 1972, **94**, 6190.
128. Inhibition studies were kindly carried out by Fujisawa Pharmaceutical Co. Ltd., Ibaraki, Japan.
129. Kindly supplied by Marion Merrell Dow.

