

AN LFG APPROACH TO  
OLD ENGLISH CONSTITUENT ORDER

Kyle Mahowald

A THESIS

in

General Linguistics and Comparative Philology

23,914 words

Presented to the Faculties of the University of Oxford in Partial  
Fulfillment of the Requirements for the Degree of Master of Philosophy

2011



# Acknowledgements

First and foremost, I want to thank Professor Mary Dalrymple, who has been the best thesis adviser a student could ask for. From the early days of getting XLE going to the nitty-gritty of the analysis to the final stages of editing and proofreading, she has never been anything but encouraging, insightful, and accessible. In the last two years, I learned an enormous amount about syntax and linguistics. So much of that is thanks to Professor Dalrymple and it is much appreciated.

Within the department, I also deeply appreciate the incomparable Professor Aditi Lahiri for all that she has taught me. The way that she freely draws on psycholinguistics, historical linguistics, and whatever else suits her purposes is inspiring and a fantastic model for us students.

Dr. Louise Mycock contributed to the information-structural analysis of word order freezing presented here—a valuable addition indeed. I did not get to talk to Louise until quite late in the thesis-writing process but I'm glad I did. I also appreciate all the technical support from my XLE comrade Jonathan Lipps as well as our many conversations about LFG. And, of course, Kate Dobson is indispensable to the life of any Oxford linguist.

Moreover, I gratefully acknowledge a helpful exchange with Hal Tily about the psychological implications of language change, Susan Pintzuk on the YCOE corpus, and Tony Kroch about Old English and language change in general.

And, finally, my flatmates Max Kleiman-Weiner and Dan Roberts have lis-

tened to more ranting and rambling about Old English, syntax, LFG, and the Germanic foot than they thought possible. And I appreciate that.

# ABSTRACT

## AN LFG APPROACH TO OLD ENGLISH CONSTITUENT ORDER

Kyle Mahowald

Old English (OE) differs from Present Day English (PDE) in many ways although the most noticeable is perhaps constituent order. Many generative analyses from van Kemenade (1987) to Pintzuk (1999) have sought to explain Old English word order, but no purely transformational account has successfully explained the data. In this thesis, I show how the multi-projection architecture of Lexical-Functional Grammar (LFG) can explain the data in a way unavailable to transformational accounts. While the thesis treats several different areas of grammar, there are consistent themes that emerge throughout. I will first survey the basic data that an analysis of Old English should seek to explain. This will be the focus of Chapter 1. From there, I will consider previous analyses of OE including head-first accounts, head-final accounts, the competing grammars account, and Clark's 2004 OT-LFG analysis in Chapter 3. Chapter 4 will introduce the basics of LFG with specific reference to Old English. The main body of the paper will focus on elements of my own lexical-functional analysis of Old English, which has been developed and tested using XLE (Crouch et al., 1998). Through the interplay of the f-structure and c-structure, LFG improves our understanding of OE syntax. Chapter 5 builds upon Clark (2004) by proposing a novel hierarchical verb cluster. Chapter 6 offers a discourse-based account of OE constituent order within the LFG framework. And Chapter 7 points the way towards an improved formal analysis of word order freezing in LFG. My conclusion offers final thoughts and directions for future research.

Although this project grew out of a desire to analyze Old English systematically and without stipulation, it has largely become an effort to develop and analyze the relationships between the multiple projections available in LFG, specifically the effects of these relationships on the constituent structure. Besides just offering a fascinating laboratory for testing the bonds that hold together various parts of syntactic structure, Old English is an important language to study for its diachronic implications. If we can develop a coherent picture of Old English syntax and understand how and why constituents get ordered in OE in the way that they do, we are a step closer to understanding how and why the language has changed in the way that it has. For example, it is not insignificant that the verb cluster I propose in Chapter 5 is rare in Middle English and vanishingly rare by Shakespeare's time. In the space available in this thesis, I will be unable to delve too deeply into these diachronic considerations. But I believe that much of what is presented here is essential to that project and can point to exciting new directions in diachronic syntax and ultimately contribute to a clearer picture of language change. And language change is a powerful window into the way that language works as a whole.



# Contents

<b>Acknowledgements</b>	<b>iii</b>
<b>Abstract</b>	<b>v</b>
<b>Contents</b>	<b>vii</b>
<b>1 Introduction</b>	<b>1</b>
1.1 Old English word order . . . . .	1
1.2 Multi-projection approach . . . . .	2
<b>2 Introduction to Old English</b>	<b>7</b>
2.1 Some words on Old English . . . . .	7
2.2 Survey of constituent order . . . . .	10
2.2.1 Placement of the verb . . . . .	10
2.2.2 Placement of the subject and adverbs . . . . .	17
<b>3 Generative Accounts of Old English</b>	<b>25</b>
3.1 Introduction to Old English generative studies . . . . .	25
3.2 Head-final analyses . . . . .	26
3.3 Competing grammars . . . . .	31
<b>4 Introduction to LFG for Old English</b>	<b>43</b>
4.1 The basics of LFG . . . . .	43

4.2	Clark's account of Old English . . . . .	49
<b>5</b>	<b>Verbs and Verb Clusters</b>	<b>55</b>
5.1	Introduction . . . . .	55
5.2	Verb clusters . . . . .	55
<b>6</b>	<b>Information Structure and the Subject</b>	<b>69</b>
6.1	Syntactic approach to subject position . . . . .	70
6.2	A discourse-based approach . . . . .	73
6.3	An LFG account of information structure . . . . .	76
<b>7</b>	<b>Word Order Freezing</b>	<b>83</b>
7.1	Introduction to word order freezing . . . . .	83
7.2	Russian word order freezing in LFG . . . . .	86
7.2.1	Bloom's account . . . . .	86
7.2.2	Information-structural account of Russian freezing . . . . .	93
7.3	Dutch and Old English word order freezing . . . . .	96
7.4	Word order freezing in LFG . . . . .	97
7.5	Word order freezing in LFG with OT . . . . .	104
7.6	On psychological reality . . . . .	106
<b>8</b>	<b>Conclusion</b>	<b>109</b>
	<b>Bibliography</b>	<b>113</b>

# Chapter 1

## Introduction

### 1.1 Old English word order

In the much studied transition from Old English (OE) to Present Day English (PDE), perhaps the most noticeable changes happen in constituent order. While it was once erroneously claimed that the word order of Old English was free, as in Fries (1940, 199): “the order of words . . . has no bearing whatever on the grammatical relations involved,”<sup>1</sup> it is now widely accepted that the order of constituents in OE is constrained in various ways. Nonetheless, OE word order was certainly far freer than that of PDE. Indeed, English transformed from a language with a relatively free word order, including frequent OV constructions, to one with a rigid VO order. A constantly expanding body of work has sought to explain precisely how and why this happened—as well as why it matters. Taylor and van der Wurff (2005, 1) describe the salience of the OV-VO, for instance, issue as being evident in “the amount of intrinsic interest, the number of knock-on effects, or the sheer volume of scholarly work devoted to it.”

Besides this major transition, there have been many other dramatic changes

---

<sup>1</sup>Cited in Bean (1983, 112)

in word order that become apparent through a comparison of Old English and PDE. To understand these changes, it is necessary to develop a theoretically and internally consistent account of Old English constituent order. Doing so requires investigating not only the relative positions of objects, subjects, and verbs, but also exploring what causes different orders to occur. Are there discourse effects? Is there word order freezing in certain otherwise ambiguous constructions? If so, how do we explain it syntactically? Why are certain logically possible structures not available in the corpus? When it comes to Old English, questions like these abound.

A review of the sea of analyses offered to explain the syntax of Old English reveals that OE is not a language that fits easily into movement-based theories of generative syntax. In her argument against a Kaynian head-initial analysis of Old English (after Kayne (1994)), Pintzuk (2005, 116) writes “[i]f a theory, however ‘elegant,’ cannot account for the data in a nonstipulative way, then the theory must be modified or abandoned.” Indeed, in this paper I will argue that, just as Pintzuk insists that no head-initial analysis successfully explains OE, in fact no movement-based theory can provide a nonstipulative account of Old English word order. Highly inflected, Old English is a language that relies heavily on information provided by the morphology. Word order, at times, seems secondary. As a result, movement-based theories that focus exclusively on constituent structures have difficulty accounting for all of the possible word orders of Old English. What we need is an architecture that allows other types of structure to interface with constituent structure.

## **1.2 Multi-projection approach**

By demonstrating the difficulties faced by traditional generative accounts of Old English, I will join a growing chorus of syntacticians who favor constraint-based

approaches that eschew movement. In a controversial attack on transformational grammar, Evans and Levinson (2009, 441) write, “[S]yntactic theories developed in the English-speaking world have primarily focussed on constituency, no doubt because English fits the bill.” While there are certainly arguments to be made against Evans and Levinson both on this point and others, it seems especially problematic that these theories with an alleged English bias struggle to account for Old English: the direct linguistic ancestor of the modern English that the theories explain best.

Despite its laxness compared to PDE, OE constituent order is not as arbitrary and opaque as it initially appears. I will argue that the multi-layered projections of Lexical-Functional Grammar (LFG) — the functional structure and the constituent structure — allow Old English constraints to be accounted for without resorting to stipulations. Thus, I hope not only to offer an analysis that illuminates the controversial topic of OE word order but also to demonstrate the benefits of LFG as a theory of generative grammar. Doing so will require exploring and in some cases modifying various aspects of the existing LFG architecture in order to fit the data. Specifically, I propose an original hierarchical verb cluster, a unique interpretation of information structure, and a new application of recent work on case indeterminacy (Dalrymple et al., 2009) in the form of a novel way to handle word order freezing in LFG.

While the thesis treats several different areas of grammar, there are consistent themes that emerge throughout. Because my findings have been implemented and tested in Xerox’s LFG-based grammar engineering software XLE, there is a focus on developing a theory that rigorously and uncompromisingly explains the Old English data. I will first survey the basic data that an analysis of Old English should seek to explain. This will be the focus of Chapter 1. From there, I will consider previous analyses of OE including head-first accounts, head-final accounts, the competing

grammars account, and Clark's 2004 OT-LFG analysis in Chapter 3. Chapter 4 will introduce the basics of LFG with specific reference to Old English. The main body of the paper will focus on elements of my own lexical-functional analysis of Old English, which has been developed and tested using XLE (Crouch et al., 1998). Chapter 5 builds upon Clark (2004) by proposing a novel hierarchical verb cluster. Chapter 6 offers a discourse-based account of OE constituent order within the LFG framework. And Chapter 7 points the way towards an improved formal analysis of word order freezing in LFG. My conclusion offers final thoughts and directions for future research.

Although this project grew out of a desire to analyze Old English systematically and without stipulation, it has largely become an effort to develop and analyze the relationships between the multiple projections available in LFG, specifically the effects of these relationships on the constituent structure. Because Old English is a language whose word order can vary dramatically based on factors other than just constituent structure, it provides an ideal testing ground for exploring this very issue. My work on verb clusters that are rooted alternatively in S or IP can be seen as an investigation of the much-studied relationship between c-structure and f-structure. The sections that deal with i-structure and *its* relationship to word order necessarily requires studying the complex way in which constituent information flows from and interacts with discourse structure. And, even though word order freezing is an effect whose existence in Old English is based on relatively little data, the analysis presented here has wide-ranging cross-linguistic implications that require i-structure, f-structure, and even processing constraints to come together to determine c-structure.

Besides just offering a fascinating laboratory for testing the bonds that hold together various parts of syntactic structure, Old English is an important language to study for its diachronic implications. If we can develop a coherent picture of Old

English syntax and understand how and why constituents get ordered in OE in the way that they do, we are a step closer to understanding how and why the language has changed in the way that it has. For example, it is not insignificant that the verb cluster I propose in Chapter 5 is rare in Middle English and vanishingly rare by Shakespeare's time. How and why did this construction drop out of the language? In the space available in this thesis, I will be unable to delve too deeply into these diachronic considerations. But I believe that much of what is presented here is essential to that project and can point to exciting new directions in diachronic syntax and ultimately contribute to a clearer picture of language change. And language change is a powerful window into the way that language works as a whole.



# Chapter 2

## Introduction to Old English

### 2.1 Some words on Old English

Like many early European languages, Old English preserves much more of its Indo-European heritage than does its modern descendant. OE had four or sometimes five cases: nominative, accusative, dative, genitive, and an optional instrumental that is only occasionally attested. OE conjugated verbs for person and number and had a morphologically encoded subjunctive mood. As a result, the actual linear order of the elements within the clause could vary. But a number of fundamental questions remain about how best to understand this order: whether OE is a V2 language like modern German, whether it has an underlyingly OV or VO order or allows for both, whether it allows for head-final clauses to occur, whether pronouns hold a different syntactic status than full DP's, whether pragmatic factors play a role in word order—the list could go on. Any analysis of OE must seek to answer these questions. Before doing so, it is first necessary to present a selection of data on Old English word order.

Corpus-based studies of the relatively small body of Old English poetry and prose are notoriously difficult because of the scarcity of samples and the absence

of any recorded speech. Moreover, the so-called “Old English period” is typically said to have begun sometime after the Anglo-Saxons’ arrival in England in 449 and lasted until shortly after the Norman Conquest in 1066. If the period indeed stretches from, say, 500 until 1100 as is often claimed, that represents a period of 600 years during which there was presumably significant linguistic change. Further difficulties arise in that different genres, as they do today, can manifest different registers of language that can affect syntax. In particular, Warner (2006) shows that historical English syntax can be heavily influenced by genre. Data is also skewed by the heavy bias in the Anglo-Saxon period for texts to be written by men, almost never women, and specifically men from advantageous socioeconomic backgrounds. Any syntactic effects unique to women or the working classes have likely been lost forever.

Moreover, there was no real dialectal standardization during the OE period, with the possible exception of a West Saxon dialect written by Ælfric and his contemporaries in the 10<sup>th</sup> century. Consequently, difficulties arise when classifying Old English into clearly defined dialects. The traditional approach is to define four dialects: the aforementioned West Saxon alongside Kentish, Northumbrian, and Mercian—with the latter two grouped together as the Anglian dialects. Most work on dialect variation, however, focuses on phonology and not syntax. Although Hogg (2006) notes that there was at least some syntactic variation among dialects, it was likely minor compared to differences in phonology. With a few exceptions, syntax seems fairly stable geographically.<sup>1</sup>

Still, the variation across space, time, and genre might seem problematic in designing a consistent grammar of a unified language we call Old English. Most of my data—as well as much of the data used by other OE scholars cited in this paper—

---

<sup>1</sup>Hogg (2006) provides an excellent account of the problems inherent in Old English manuscript studies as well as a survey of the main Old English dialects. Clark (2004) thoroughly addresses the complex issues faced in these studies.

will be drawn from the Taylor et al. (2003) York-Toronto-Helsinki Parsed Corpus of Old English Prose (YCOE) using CorpusSearch (Randall, 2000). The corpus consists of a collection of Old English texts taken from a mix of places, times, and genres. In addition to being syntactically parsed, YCOE texts are helpfully marked with the manuscript's place or origin, estimated date of composition, genre, and whether or not it is original prose or based on a translation from Latin.

By considering all of these factors, I believe that it is possible to make the type of generalizations necessary to construct a grammar of the language. For instance, when a certain logically possible construction, like the reverse brace construction discussed below, is attested only two times out of thousands of clauses from a wide variety of different dialects, time periods, and genres, that should raise significant red flags as to the permissibility of the construction. When a syntactic feature varies based on one of these textual factors, I will make every effort to note that and account for it in my analysis of the data to follow. Sometimes, we may find that certain constructions are extremely rare across time and space but not necessarily ungrammatical.<sup>2</sup> Or we might expect not to find pronouns in certain positions reserved for new information. That is not to say that their appearance in such a location would be impossible. That said, if a construction is extremely rare and there is no apparent reason why this should be so, it seems safe to declare the construction either ungrammatical or at the very least strongly dispreferred.

---

<sup>2</sup>As an analogy, consider the parasitic gap construction, which is rare in modern English but perfectly grammatical.

## 2.2 Survey of constituent order

### 2.2.1 Placement of the verb

Having acknowledged the hurdles inherent in this type of analysis, I will now turn to the data itself. Every possible order of the subject, object, and verb is attested in Old English: SVO, SOV, VOS, VSO, OVS, OSV. While this may seem like a free-for-all, it is generally agreed that the unmarked word order is S-initial. The other variants are associated with discourse effects, such as topicalization. For instance, Allen (1995, 44) posits a number of conditions that apply when a sentence is O-initial: “[e]ither the object is seen as more important than the subject, the more important information is towards the end of the sentence, or the sentence is part of a list.”<sup>3</sup> She also notes that, contrary to occasional misleading claims, both OVS and OSV orders occur in subordinate clauses as well as in root clauses.<sup>4</sup> Below are examples of such object fronting in subordinate clauses.<sup>5</sup>

#### (2.1) OVS

*...þæt ðurh andan hine sealdon þa heahsacerdas*  
 that through envy him-O gave-V the high priests-S.  
 ‘...that the high priests gave him through envy’  
 (cowsgosp,Mk\_[WSCp]:15.10.3443)

#### (2.2) OSV

*...þæt hine man beswican wolde*  
 that him-O one-S deceive wanted-V.  
 ‘...that one wanted to deceive him’  
 (cochronD,ChronD\_[Classen-Harm]:1016.15.1615)

---

<sup>3</sup>That is, an object is fronted to highlight its importance, or sometimes an unimportant object is fronted to indicate that the important information is still to come.

<sup>4</sup>OVS does not occur with a pronominal subject. We will return to this later.

<sup>5</sup>Unless otherwise specified, OE examples used in this paper were found using the YCOE and are cited following YCOE citation notation.

Following e.g. Allen (1995), Pintzuk (1999), Clark (2004), however, I will assume that these instances represent a topicalized object. So our grammar must allow for the possibility of a topic position in which the object can appear clause-initially.

The V-initial sentences VSO and VOS also represent special word orders.<sup>6</sup> Verbs typically appear pre-subject in a number of special cases: interrogative clauses, negative clauses, and when the V is preceded by certain adverbs like *þa*. As with so-called “object fronting,” verb-fronting can occur in both root and subordinate clauses. Examples appear below.

(2.3) interrogative clause

*La, hu mæg blind man oðerne lædan?*  
indeed, how can-V blind man-S other lead?  
‘Indeed, how can a blind man lead another?’  
(coinspolX,WPol\_2.1.1\_[Jost]:118.164)

(2.4) negative clause:

*ne edon hi swa feor up.*  
neg went-V they-S so far up.  
‘They did not go so far up.’  
(cochronD,ChronD\_[Classen-Harm]:1001.4.1302)

(2.5) *þa/þonne* clause:

*þa gehældan hiene ða apostole Petrus & Iohannes...*  
then held-V him the apostles Peter and John-S  
‘Then the apostles Peter and John held him.’  
(cobede,Bede\_5:2.390.8.3885)

---

<sup>6</sup>When I discuss the V in these sentences, I am referring to the finite verb, which may or may not be the main verb.

(2.6) V-initial declarative:

...*bærin* *geat*      *bæt* *wif*      *þa* *deorwyrþan* *smerenesse* *on* *his*  
 therein poured-V the woman-S the valuable ointment on his  
*heafod*...  
 head  
 ‘therein the woman poured the valuable ointment on his head’  
 (coblick,HomS\_21\_[BlHom\_6]:73.115.905)

The final example, a V-initial declarative, lacks the special features associated with V-initial clauses. But Allen (1995, 34) notes that only verbs that “carry a very light semantic load” or “else have already been introduced into the discourse” can appear in first position in declarative sentences. V-initial order has a “clearly stylistic function in narrative prose” (Seoane, 2006, 364). It causes the emphasis to shift to the subject and, as a result, prominent verbs rarely appear there. The corpus supports this notion, and it is safe to consider V-initial declarative sentences a marked order. In 2.6, for example, the “ointment” has already been introduced into the discourse as something that might be used for pouring and thus its “pouring” is unsurprising and conveys relatively little information.

Because of the special nature of both V-first and O-first sentences, I will focus the majority of my attention in the coming sections on subject-initial clauses. Whereas both SVO and SOV freely occur when there is only one finite verb, the situation becomes more complex—and more constrained—in sentences with more than one verbal element. I have examined the YCOE for sentences with two verbs: a finite verb and a main verb. Following the practice of the YCOE, finite verbs can be modals that take infinitival complements, perfective *have*, passive *be*, progressive *be*, and auxiliaries that include raising verbs like *cuman* ‘come’ and *feran* ‘go’ since those are often used aspectually in OE (Haeberli and Pintzuk, 2006, 21). Out of the six logically possible orders involving S-initial sentences and two verbs, five are

well attested.<sup>7</sup>

Haeberli and Pintzuk (2006) provide useful data on the order in which finites and auxiliaries can appear. They number the verbs 1, 2, and 3 where the finite verb is 1, 1's complement is 2, and the complement of 2 is 3. Thus, *should be broken* would have 1-2-3 order, *should be* 1-2, *be should* 2-1, and so forth. The Haeberli and Pintzuk (2006) data comes from the YCOE corpus, and they examine only subordinate clauses. While they find that the order of the finite verb and its complement in two-verb sentences varies between 1-2 and 2-1 based on the type of finite verb, for our purposes it is most important to note that, while perfective *have* shows 1(...)2 order 33.9% of the time, other finite verbs hover between 60.0-64.4% for 1(...)2 order with the remaining instances being 2-1.<sup>8</sup> Thus, both orders occur frequently enough to consider them regular accepted orders in OE subordinate clauses. Examples:

(2.7) Aux V O

...þæt he wolde      gefremman þa læssan leahtras...  
 ...that he wanted-1 do-2      the lesser crimes-O  
 '...that he wanted to do the lesser crimes'  
 (colsigewZ,æLet\_4\_[SigewardZ]:1085.494)

(2.8) Aux O V

...þæt he wolde      mid weorcum þæt gefyllan...  
 that he wanted-1 with deeds      that-O baptize-2  
 'that he wanted to baptize it with deeds'  
 (coelive,æLS\_[Martin]:404.6220)

---

<sup>7</sup>The unattested order is the so-called reverse brace construction V O Aux and is discussed at length below.

<sup>8</sup>Verbs that take complements that were searched for by Haeberli and Pintzuk include modals, perfective *have*, passive *be*, progressive *be*, and the auxiliary.

(2.9) O V Aux

*...þæt he eallu þing gehealdan wille*  
 that he all things-O keep-2 wants-1  
 ‘that he wants to keep all things’  
 (cobenrul,BenR:58.99.8.1047)

(2.10) O Aux V

*...þæt hie heora synna cunnon onrihtlice geandettan...*  
 that they their sins-O know.how.to-1 rightly confess-2  
 ‘that they know how to rightly confess their sins’  
 (coblick,HomS\_14\_[BlHom\_4]:43.72.554)

(2.11) V Aux O

*...þæt Chyron centaurus findan sceolde þas wyrta-O...*  
 that Chyron centaur find-2 should-1 the plants-O  
 ‘that Chyron the centaur should find the plants’  
 (coherbar,Lch\_I\_[Herb]:36.0.789)

The sixth logically possible order V O Aux is extremely rare in the corpus, and it is widely assumed that it was ungrammatical in Old English. This is what Clark (2004) calls the “reverse brace” construction. Pintzuk (2005) reports that, among V O Aux constructions, a thorough search of the YCOE turns up only three instances of clauses in which an element intervenes between a verb and an “unambiguously” clause-final auxiliary. In all three cases, the intervening element is a light element like an adverb or a PP and not an object. This speaks to the fact that the absence of the reverse brace construction is more broadly linked to a constraint on verb-auxiliary adjacency. Haeberli and Pintzuk (2006) point out that when 2-1 order occurs, the verbs are almost always adjacent: only 11 out of 7471 clauses with two verbs do not fit this generalization (.15%). While this percentage is likely low

enough to deem the structure ungrammatical, I reiterate that when intervening elements do occur, they tend not to be the main arguments of the sentence but are usually adverbs, prepositional phrases, and the like. Thus, the nonadjacency is less extreme than it would be were the intervening element a full NP argument. See, for instance, the following example of this rare non-adjacency from Pintzuk (2005):

- (2.12) ...*hu hie gedon ymbe þa menn haefdan*  
          how they done about the men had  
          ‘how they had dealt with the men’  
          (cobede, Bede\_5:11.416.25.4189)

As Pintzuk (2005) notes, any good analysis of OE should account for the absence of this construction as a viable option.<sup>9</sup>

Let us then assume that, when a finite verb follows its complement verb, the two must be adjacent whereas, if the complement verb follows the finite verb, other elements may intervene.<sup>10</sup> If this assumption is valid, then we would expect it to hold in clauses with three verbal elements. And it does. Two significant studies of such clauses have been undertaken: Koopman (1990) and Haeberli and Pintzuk (2006). No OE clause has more than three verbal elements and, when three verbs occur, they consist of a finite verb (1), an infinitive *beon*, *weorþan*, *wesan*, or *habban* (2), and a participle (3). Haeberli and Pintzuk (2006) find that, in 430 clauses with three verbs, 1-2-3 order (*should be broken*) occurs 306 times (71.2%), 1-3-2 (*should broken be*) 48 times (11.2%), 3-2-1 (*broken be should*) 67 times (15.6%). Thus, while 1-2-3 is the most common, all three of these orders appear to be grammatical in OE. 2-1-3 (2 times or .5%) and 3-1-2 (7 times or 1.6%) are marginal, and 2-3-

---

<sup>9</sup>See Pintzuk (2005) for an analysis of this. For a summary of earlier work on this constraint, see Sonoda (1998, 313). Hiyama (2004) identifies three apparent counterexamples but explains two of them away through textual emendation and attributes the last to the influence of the Latin source text.

<sup>10</sup>Clark (2004, 122) cites personal communication from Kozo Kato that makes a similar claim.

1 never occurs.<sup>11</sup> Haeberli and Pintzuk (2006) claim that only the first three are grammatical. 161 clauses have these elements non-adjacent, and 131 of those clauses with non-adjacency have 1-2-3 order. They found only three cases of unexpected non-adjacency.

Table 2.1: Sampling of clauses with three verbs from Haeberli and Pintzuk (2006):

Order	Example	Corpus %	Non-Adjacency Allowed?
1-2-3	‘should be broken’	71.2%	yes
1-3-2	‘should broken be’	11.2%	yes, between 1 and 3
3-2-1	‘broken be should’	15.6%	no
2-1-3	‘be should broken’	.5%	yes
3-1-2	‘broken should be’	1.6%	?
2-3-1	‘be broken should’	0%	N/A

Koopman (1990) finds similar results but comes to a slightly different conclusion. He concurs that the orders 1-2-3, 1-3-2, and 3-2-1 are grammatical and that 2-3-1 is ungrammatical. He does, however, reserve the possibility that 2-1-3 and 3-1-2 are at least weakly grammatical. My own exhaustive search of subordinate clauses in the YCOE dovetails with what was found by the previous efforts: 2-1-3 and 3-1-2 show up a smattering of times, whereas 2-3-1 is entirely unattested. Interestingly, in the two instances of the order 2-1-3 that I found, one of them showed nonadjacency 2-1(...)3.

(2.13) ...*tæt ðær nænig whit wyllsprynge* *beon mihte on gesewen.*  
that there not-any whit spring be-2 might-1 on seen-3  
‘...that not a whit of spring might be seen in it’  
(cobede,Bede\_4:29.366.17.3667)

All of the examples of 3-1-2 that I found, however, show adjacency among the verbal elements. My analysis shows that 1-2-3 is by far the most common in subordinate clauses and even more common in root clauses.

---

<sup>11</sup>Wurmbrand (2006, 241), cited in Haeberli and Pintzuk (2006), claims that 2-3-1 is never attested in any Germanic languages.

Thus far, our theory of Old English reveals the following generalizations about Old English word order:

- (i) Although the subject usually appears first, the object and verb can sometimes appear in initial position to achieve different discourse effects.
- (ii) There are special constructions that occur with interrogatives, negatives, and certain adverbs in which the verb appears initially.
- (iii) In sentences with two verbs, every possible order of the finite verb, non-finite verb, and object is allowed with the exception of the reverse brace construction:  
V O Aux.
- (iv) In sentences with three verbs, 1-2-3, 1-3-2, and 3-2-1 are allowed. Some argue that 2-1-3 and 3-1-2 order is rare but permissible, whereas others have claimed that both are ungrammatical. An ideal analysis would provide a means by which 2-1-3 and 3-1-2 are not entirely disallowed but are weakly grammatical. 2-3-1 is by consensus ungrammatical. When a licensing verb precedes its complement, elements may intervene. When the complement precedes its licensing verb, the two must be adjacent.

### 2.2.2 Placement of the subject and adverbs

In addition to accounting for the variable placement of the verb, any theory of Old English word order must account for the asymmetry between the placement of pronominal arguments and nominal ones. Pronouns and adverbs can often appear before the verb where one might otherwise expect V2 order—a clause structure common to Germanic languages in which the finite verb must be the second constituent element in the root clause. When a non-pronominal non-subject element appears before the finite verb, pronominal subjects invariably also appear before

the finite verb unless the clauses are direct questions, have V1 order, or contain a discourse adverb like *þa/þonne*. Full noun phrase subjects can appear either before or after the finite verb. These generalizations hold in both root and subordinate clauses.

Along those lines, Koopman (1998) investigates seven OE texts and finds that subject pronouns, with a few notable exceptions, always appear before the finite verb when an object is topicalized. The first three orders below are attested, whereas the last is one of the very rare examples in which an element is topicalized yet the pronominal subject follows the finite verb. Allen (1995) and others consider the order O V ProSubj to be disallowed.

(2.14) O Aux FullSubj V

*ðisne geleafan woldon            dwolmen            aidlian...*  
 this belief-O wanted-AUX chaos-FULLSUBJ empty-V  
 ‘Chaos sought to obviate this belief’  
 (cosevensl,LS\_34\_[SevenSleepers]:330.248)

(2.15) O FullSubj Aux V

*þisne æþeling Cnut cyng            hæfde            forsend on*  
 this prince Cnut king-FULLSUBJ had-AUX sent-V to  
*Ungerland to beswicane*  
 Ungerland to deceive  
 ‘Cnut the king had sent this prince to Ungerland in order to deceive’  
 (cochronD,ChronD\_[Classen-Harm]:1057.5.2089)

(2.16) O ProSubj Aux V

*þas wyrte ðu scealt niman on ðam monðe þe*  
the plants you-PROSUBJ shall-AUX take-V in the month that  
*man Aprelis nemneð.*  
one April names  
‘You should take the plants in the month called April’  
(coherbar,Lch\_I\_[Herb]:6.1.374)

(2.17) O Aux ProSubj V<sup>12</sup>

*\*þæt wille ic gecyþan, þæt*  
that-O will-AUX I-PROSUBJ make-known-V, that  
‘I will make it known that...’  
(Orosius, 37.2 [SOURCE: Koopman (1998, 137)])

Thus, it seems that there is more freedom in the placement of full noun phrase subjects than of pronominal ones. This is borne out by evidence from negative constructions. Typically, a negative is constructed with an initial *ne* + V. The *ne* is a proclitic and always appears immediately before the finite verb. There is also a negative adverb *na*, used to strengthen the negation. When the subject is a full NP, the negative adverb can appear either before or after the subject.

(2.18) ...*ne* *bepurfon na* ða *halan læces...*  
NEG need NEG-ADV the hearty-SUBJ gift  
‘The hearty do not need help’  
(cowsgosp,Mk\_[WSCp]:2.17.2307)

(2.19) *ne byð se man na cristen*  
NEG is the man NEG-ADV Christian  
‘the man is not Christian’  
(coprefgen,æGenPref:20.16)

As Rissanen (1998) shows based on an examination of the Helsinki Corpus,

V + NEG-ADV + PRO-SUBJ is not found. That is, when a pronominal subject is involved, the only possible order is V + PRO-SUBJ + NEG-ADV:

- (2.20) *ne mæg þæt na beon þæt...*  
 NEG can that-SUBJ NEG-ADV be that...  
 ‘it cannot be that...’  
 (coblick,HomS\_47\_[BlHom\_12]:13114.1610)

The word order exemplified by the following constructed sentence, on the other hand, is not attested in the corpus:

- (2.21) *\*ne bræc na he þone stan*  
 NEG broke NEG-ADV he the stone  
 ‘he did not break the stone’

Although attested, the order NEG + NEG-ADV + PRO-SUBJ is rare enough to be considered ungrammatical. See also van Kemenade (1999) and Pintzuk (1999) for a discussion of this phenomenon.

van Kemenade (1987) and Pintzuk (1999) both explain the special placement of pronominal subjects by asserting that they are clitics. One consequence of this theory is that it allows V2 order to be maintained even when it is apparently violated as in Example 2.16. If the pronoun *ðu* in 2.16 is considered a clitic, then it would not count as an element and *scealt*, the finite verb, would still appear in second position. As Haerberli (2002) points out, however, V2 is violated much more frequently than just in these cases. He writes, “It is therefore not entirely adequate to talk about the ‘loss of V2’ in English since there is no attested period in the history of this language during which it had the properties of a typical V2 language” (252). Consider, for instance, Example 2.15 above, which flagrantly violates V2 by having two full NP arguments before the verb. In formulating a grammar of OE, perhaps the best solution is to say that OE is V2-like but not strictly V2.

There is another important asymmetry to consider between full noun phrase

subjects and pronominal ones: the instances in which the subject follows or precedes an adverb like *þa* or *þonne*. When the subject is not a pronoun but a full NP, it can appear either to the left or the right of the adverb:

- (2.22) *Soð þæt is þæt seo sunne                    ða            stod        anes*  
           true that is that the sun-FULLSUBJ then-ADV stood-V one  
           *dæges lencge*  
           day's length  
           ‘It is true that the sun then was up for one day.’  
           (cotempo,æTemp:7.2.245)

- (2.23) *Gif ðonne        Englisc onstal                    ga        forð...*  
           if then-ADV English accusation-FULLSUBJ goes-V forth  
           ‘If then English accusation goes forth’  
           (colawine,LawIne:46.1.125)

van Kemenade (2009) provides data that shows that shows that in subordinate clauses pronominal subjects almost always appear to the left of *þa/þonne*. My own search confirms van Kemeande’s findings that there are only 5 examples of *þa/þonne* + PRO SUBJ in subordinate clauses in the YCOE.

- (2.24) *...nu þa                    we                    witon    &    us cuð        is þæt...*  
           now then-ADV we-PROSUBJ know-V and us known is, that  
           ‘Now that we know and that it is known to us that...’  
           (cogregdC,GDPref\_and\_4\_[C]:46.336.29.5065)

The situation becomes much more complicated, however, when main clauses are considered since there are 92 instances of *þa/þonne* + PRO SUBJ order in root clauses. It is indisputable, however, that the more common order for pronominal subjects in both subordinate and root clauses is PRO SUBJ + *þa/þonne*. My search of the corpus turned up 288 such instances in subordinate clauses and 406 in root clauses compared to only 5 instances of *þa/þonne* + PRO SUBJ in subordinate clauses and the 92 found in root clauses.

(2.25) *þa*                    *hi*                                    *gefengon*    *mycele*    *herehyðe*,  
           then-ADV they-PROSUBJ received-V much    treasure  
           ‘Then they received much treasure’  
           (cochronD,ChronD\_[Classen-Harm]:894.20.807) [92 root, 5 subordinate]

(2.26) *he*                    *ða*                    *sceal*    *to rihtre*                    *stige geteon*.  
           he-PROSUBJ then-ADV shall-V to more-correct path drawn  
           ‘he then shall to a more correct path be drawn’  
           (cobede,Bede\_5:9.412.1.4138) [406 root, 288 subordinate]

While it has been argued that the subject pronouns are actually clitics (van Kemenade (1987) and Pintzuk (1999)), van Kemenade (2009), following van Kemenade and Los (2006), asserts that *þa/þonne* act as discourse particles and that whatever appears to their left appears in a “discourse-linked area.” Because pronouns generally refer to old information, this analysis could explain why pronouns do not appear after the discourse particle *þa*. But, significantly, pronouns that act as prepositional objects behave differently from full noun phrase prepositional objects as well. This suggests the possibility that they do have a different syntactic status.

The subject asymmetry points to the larger question of the status of pronouns and light elements in Old English. In addition to appearing either before or after the verb in the VP, object pronouns can appear in the same places that subject pronouns appear. When subject and object pronouns co-occur, the subject pronoun usually appears first. When a pronominal subject and pronominal object precede the finite verb, the YCOE has 6592 cases in which the subject comes first compared to only 44 when the object comes first. Moreover, accusative pronoun objects almost categorically precede dative ones, as in Example 2.31. The order is somewhat freer when full NP’s are involved.

(2.27) *þæt heo hine ofslægenne hæfdon.*  
 that she-PROSUBJ.NOM him-PROOBJ.ACC slain-V had-AUX  
 ‘that she had slain him’  
 (cochronD,ChronD\_[Classen-Harm]:755.13.220)

(2.28) *and he him sona sænde,*  
 and he-PROSUBJ.NOM him-PRO-OBJ.DAT immediately sends-V  
 ‘and he immediately sends it to him’  
 (cochronD,ChronD\_[Classen-Harm]:167.2.73)

(2.29) *?\*and hire he ne sceþede.*  
 and it-PRO-OBJ.ACC he-PRO-SUBJ.NOM NEG injured-V  
 ‘and he did not injure it’  
 (comart3,Mart\_5\_[Kotzor]:Se16,A.18.1768) [rare construction]

(2.30) *...þonne hig hine geseoþ*  
 when they-PROSUBJ.NOM it-PRO-OBJ.ACC see-V  
 ‘when they see it’  
 (cowsgosp,Lk\_[WSCp]:20.13.5284)

(2.31) *...hu he hine-ProObj him gesealde*  
 how he-PROSUBJ.NOM it-PRO-OBJ.ACC him-PRO-OBJ.DAT  
 gave-V  
 ‘how he gave it to him’  
 (cowsgosp,Lk\_[WSCp]:22.4.5413)

To the constraints on the placement of the verb discussed in the previous section, we can now add the following to account for subject placement as well:

5. The theory should be able to account for topicalized elements appearing in first position and ensure that, when this position is filled by something other than a light element, pronominal subjects appear postverbally.

6. Pronominal subjects should not be permitted to appear after negative adverbs.  
Full NP subjects can appear either before or after negative adverbs.
7. Pronominal subjects should only rarely be allowed to appear after adverbs like *þa/þonne* in subordinate clauses but can appear after such adverbs in main clauses. As discussed above, the theory should specify this position as discourse-linked.
8. When a pronoun subject and one or two pronoun objects appear before the finite verb, the subject should precede the accusative object and the accusative object should precede the dative object.

# Chapter 3

## Generative Accounts of Old English

### 3.1 Introduction to Old English generative studies

Unsurprisingly, there have been many attempts to offer generative analyses of Old English that seek to explain and motivate the various constraints on clause structure described above. In all of these analyses, a fundamental issue is whether the Old English IP is underlyingly head-final or head-initial with the expectation that much of the rest of the analysis will fall out from there. Both sides have been vociferously argued. There are also other important issues to consider such as whether the personal pronouns are clitics. My focus in this section will be to examine previous accounts of Old English syntax, beginning with the so-called “standard analysis” proposed in the highly influential paper of van Kemenade (1987)—which argues for a head-final account of OE.<sup>1</sup> Largely in line with Kayne, there have also been a number of attempts to analyze all OE clauses as underlyingly head-initial with uniformly right-branching trees. The head-first analyses of Nunes (2002), Roberts

---

<sup>1</sup>In many ways, van Kemenade (1987) initiated modern syntactic work on OE in the generative tradition. Although her initial assumptions have been much criticized and in some cases disproven, I will follow Pintzuk (1999) in establishing van Kemenade (1987) as something of a turning point in the study of English syntax and not explicitly address many of the very interesting proposals made prior to that publication.

(1997), Wurff (1999), Biberauer and Roberts (2003), and Biberauer and Richards (2004) do not account for all of the possible positions of the verb without resorting to stipulations. Pintzuk (2005) convincingly demonstrates the impracticality of these analyses with enough conviction and efficacy that analyzing them here seems superfluous. Because both the all-head-final and all-head-initial approaches have been largely discredited, the bulk of my time will be spent on the competing grammars approach that is perhaps most widely accepted today. I will also examine Clark (2004), which proposes an OT-LFG analysis of OE that is very useful in formulating my own pure LFG account.

### **3.2 Head-final analyses**

The head-final analyses generally analyze Old English as a V2 language like Dutch or German—languages to which English is quite closely related. These languages show an asymmetry between root clauses and subordinate clauses, and the standard analysis is that they are underlyingly V-final. The V then moves to the highest functional projection, the head of CP, in root clauses. In subordinate clauses this position is often filled by a complementizer, and the V stays in the I head. Movement from I to C is blocked by the complementizer. For languages like German and Dutch, this analysis is very effective. And this is the analysis presented by van Kemenade (1987), Koopman (1990), and others for Old English. It effectively explains the asymmetry between OE subordinate clauses and OE root clauses, noted by Mitchell (1985) and van Kemenade (1987), by which root clauses frequently show V2 order, whereas subordinate clauses tend to have the finite V appear in final position. Koopman (1990) claims that between 0.6% and 6.1% of root clauses are V-final. Pintzuk (1993) finds 6.3% of root clauses to be what she calls Infl-final (which corresponds to the V being in final position as in Koopman). The

(3.1) (a) O V Aux

*þæt se cyning þone stan brecan sceolde*  
 that the king-S the stone-O break-V should-AUX  
 ‘that the king should break the stone’

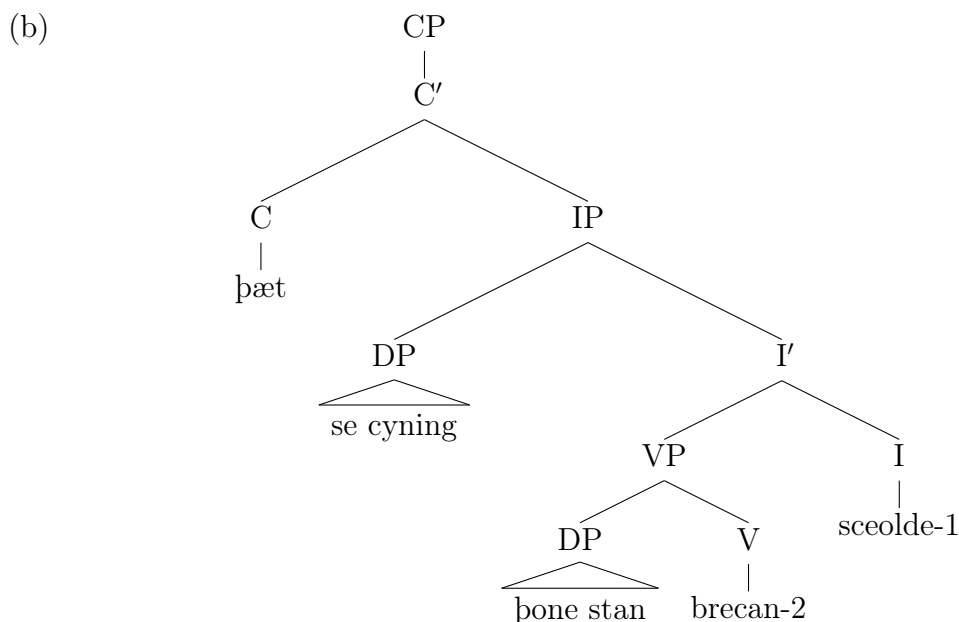

belief in this asymmetry is now quite controversial—Pintzuk and Haeberli (2008) present convincing evidence that many more root clauses are V-final than previously thought.<sup>2</sup>

The head-final analysis correctly derives the V2 order frequently found in root clauses. But it does not immediately explain why VO order is often found in subordinate clauses as well as in root clauses. Moreover, it does not explain why root clauses often fail to obey the V2 constraint in the same way that other V2 languages do. Invariably head-final accounts seek to explain these apparent contradictions through movement. van Kemenade (1987) proposes rightward verb projection raising and extraposition. I show one such subordinate clause in 3.1.

<sup>2</sup>Pintzuk and Haeberli (2008) along with Pintzuk (1999, 2005) and other work in the competing grammars tradition determine the breakdown of head-final vs. head-initial clauses by examining certain diagnostic elements that include negative objects, particles, and stranded prepositions.

(3.2) Aux O V

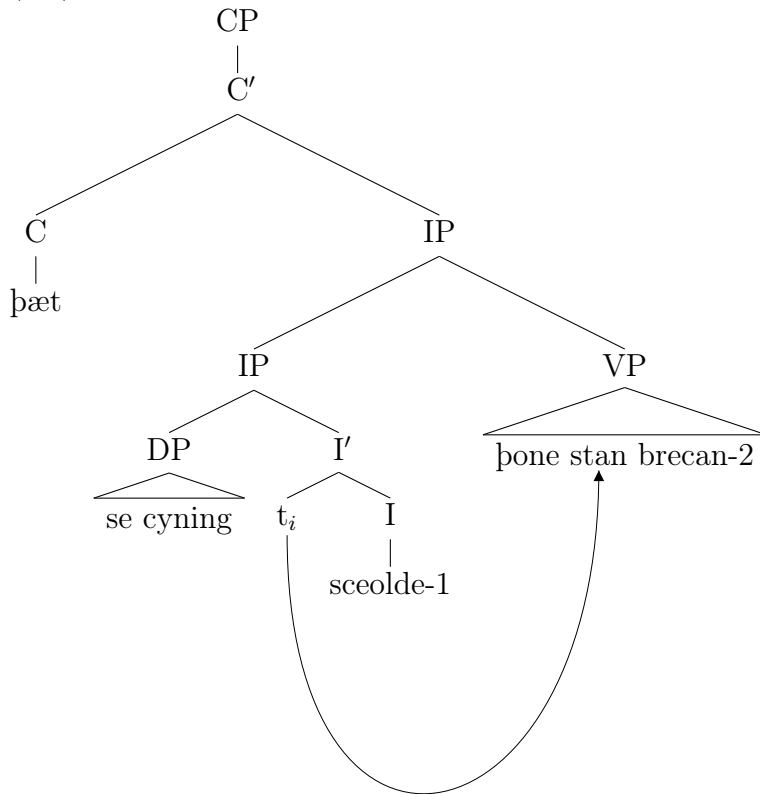

A head-final analysis assumes that S O V AUX is the underlying order, as in 3.1. The filled C position blocks any V2 movement, which is why it is important that we examine subordinate clauses in order to determine the canonical word order.

Verb projection raising (VPR) can derive the order Aux O V by adjoining the entire VP to the IP as in Example 3.2. Moreover, postposition can move an object right and adjoin it to the VP. This, however, as Example 3.3 shows, allows the unattested “reverse brace” construction. Indeed, this is a major problem faced by the all-head-final account of OE. If postposition is simply disallowed, it becomes difficult to explain how the order Aux V O is allowed, as in 3.4.

Another hurdle for the standard analysis is that OE often fails to obey V2 constraints. van Kemenade (1987) argues that, when it does not obey V2 constraints, it is because personal pronouns act as clitics. I will discuss theories of cliticization

(3.3) V O Aux (reverse brace)

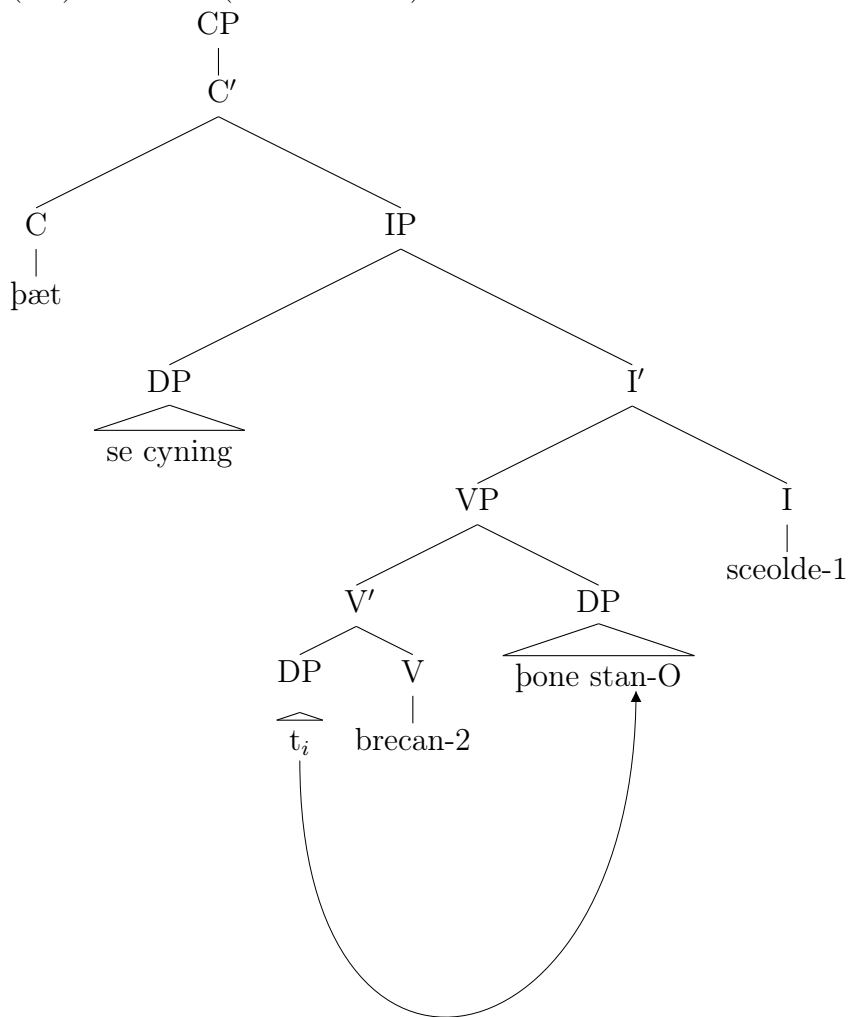

(3.4) Aux V O

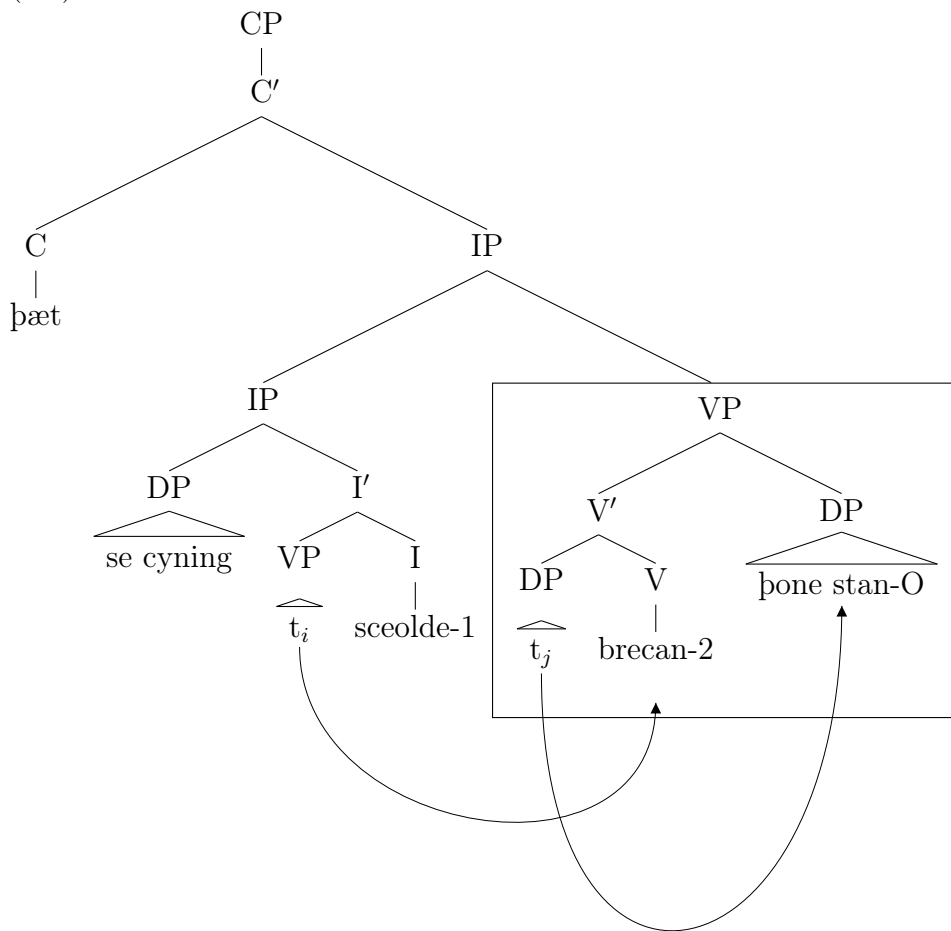

in the next section, but for now it suffices to say that van Kemeende proposes that clitics attach either to heads or to the periphery of phrases. Thus, an analysis for 3.5 would not violate V2 because the pronoun would act as a proclitic and not count as a preverbal element.

(3.5) *se cyning hit bræc*  
the king-S it-O broke-V  
'the king broke it'

The verb *bræc* would still be the second element. While this analysis has a certain appeal, as previously discussed, there are many examples of Old English sentences with multiple non-clitic elements before the verb. It is simply not true that OE root clauses must obey a V2 constraint. Any head-final analyses that insist upon such a constraint cannot explain this variation.

In summary, the standard head-final IP analysis fails to adequately explain the Old English data insofar as it cannot outlaw the reverse brace construction and insists that OE clauses should be V2 in many instances where they are not.

### 3.3 Competing grammars

The competing grammars theory, perhaps most associated with York's Susan Pintzuk, finds fault with both purely head-final and purely head-initial analyses of Old English. Pintzuk (1999) argues against the OV position and instead proposes a competing grammars model whereby both head-initial IP and head-final IP are permitted. That is, Pintzuk (1999) and Pintzuk and Taylor (2006) reject the idea proposed in Lightfoot (1991, 1999) that states that there was a sudden and dramatic switch from OV to VO sometime in the twelfth century. Rather, variation occurred between both grammars, and this variation persisted into the Middle English period while slowly shifting towards the modern SVO. In fact, Morenhout and van der

Wurff (2005) argue that OV persisted as an option until 1550. Koopman (2004) undertakes a quantitative analysis to show that VO is a genuinely permissible option. Pintzuk and Haerberli (2008) use the placement of certain diagnostic elements to reach a similar conclusion. In this section, I will present a competing grammar account of Old English based largely on Pintzuk (1999) but updated to account for recent developments. Specifically, I will turn to Pintzuk and Haerberli (2008) for the latest in the competing grammars tradition.

The crux of the competing grammars approach is, as its name suggests, that a head-initial and head-final IP are in competition with each other. The finite verb necessarily moves from V to I, so this theory has the great advantage of simply positing that by and large V-final clauses are in fact I-final, whereas V-first clauses are I-first. The verb moves to I in both situations to pick up its inflection.<sup>3</sup> In certain cases, such as in interrogative clauses and when the *þa/þonne* adverbs are involved, the finite verb moves once more from I to C. The subject starts in Spec, VP and, if it is a pronominal subject, it must move to Spec, IP. Full DP subjects can remain in Spec, VP—which explains the asymmetry in subject placement. Spec, CP is a topic position and is a third position in which subjects can appear. Non-initial complements and adjuncts can undergo both postposition to the right and scrambling to the left, where they can then appear in Spec, CP, Spec, IP, or Spec, VP. It can be assumed that the specifier will always appear on the left.

Pintzuk (1999) asserts that this movement, combined with the variability of I as either head-first or head-final, explains why Old English can *appear* to be a V2 language. By this account, verb seconding is movement of the finite verb to the head-first I position. When this happens and there is nothing in CP, there is only one place available before the finite verb: Spec, IP. The second element is then the verb in I. Not all head-first IP's, however, show V2 order since other elements—

---

<sup>3</sup>Contrary to some theories, the competing grammars theory by and large allows rightward movement.

often pronouns or light adverbs but sometimes heavier elements too—can intervene and cause V3 order to occur.

Let us examine the sentences from Chapter 2 in this framework. Aux V O and Aux O V have what Pintzuk calls INFL-medial order. The trees below are surface structures. The subject was generated in Spec, VP and the verb was generated in V. In these sentences, it is theoretically unclear whether the non-finite verb precedes or follows its complement at deep structure since there is the possibility of movement. That is, in Example 3.6 below, it is ambiguous whether the order is VO or whether it is OV with postposition. Pintzuk (1999) claims that both are possible provided that the clause is I-first. If it is I-final, then she claims that only OV order can occur as a base order.

Just as 3.1 could hypothetically be either VO or underlyingly OV with object postposition, the order Aux O V could have either a head-initial IP or a head-final IP since Pintzuk's theory allows for the possibility of both Verb Projection Raising (VPR) and Verb Raising (VR) in order to derive verb-object nonadjacency. Thus, Example 3.7 can get an analysis with I-initial IP as in 3.7c, or as in the tree for 3.7b, it could have VPR whereby the entire verb projection is extraposed.

When the finite verb appears in final position, the competing grammars analysis generally provides a stipulation that there must be OV ordering as in 3.8. Somewhat problematically, this constraint does not follow naturally from other rules but is instantiated by stipulation.

An interesting feature of Old English is that the verb and its complement can appear nonadjacent. Pintzuk (1999) assumes that this must be explained by movement. Example 3.9 shows an example of head-final IP with verb raising (VR) whereby the non-finite verb is raised to the position of the finite verb. Example 3.10 shows object postposition. Unlike in 3.8 and 3.7 these movement-based analyses are the only ones possible since the object and verb are not adjacent and thus could

(3.6) (a) Aux V O

...þæt he wolde gefremman þa læssan leahtras...  
 ...that he wanted-1 do-2 the lesser crimes-O

‘...that he wanted to do the lesser crimes’  
 (colsigewZ,æLet\_4\_[SigewardZ]:1085.494)

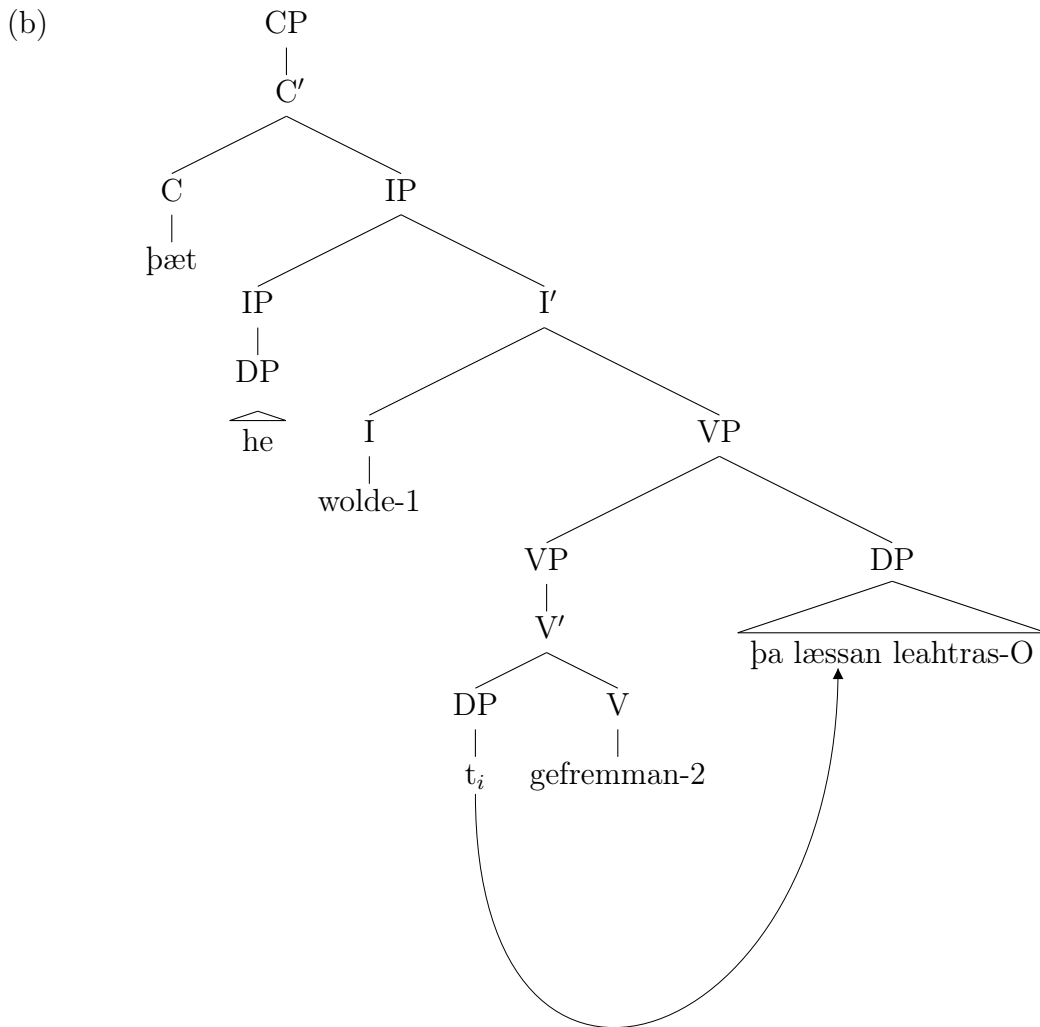

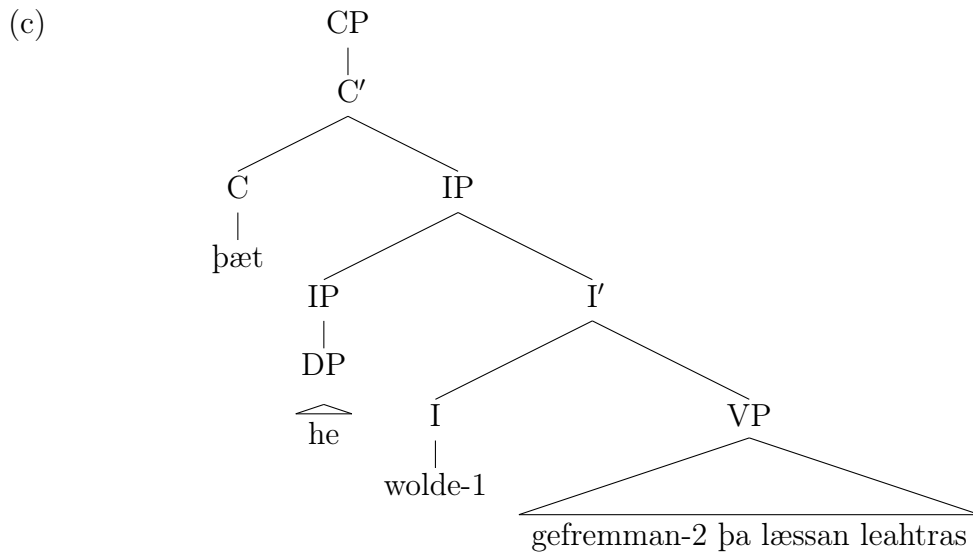

(3.7) (a) Aux O V

...þæt he wolde mid weorcum þæt gefyllan...  
 that he wanted-1 with deeds that-O baptize-2  
 ‘that he wanted to baptize it with deeds’  
 (coelive,æLS\_[Martin]:404.6220)

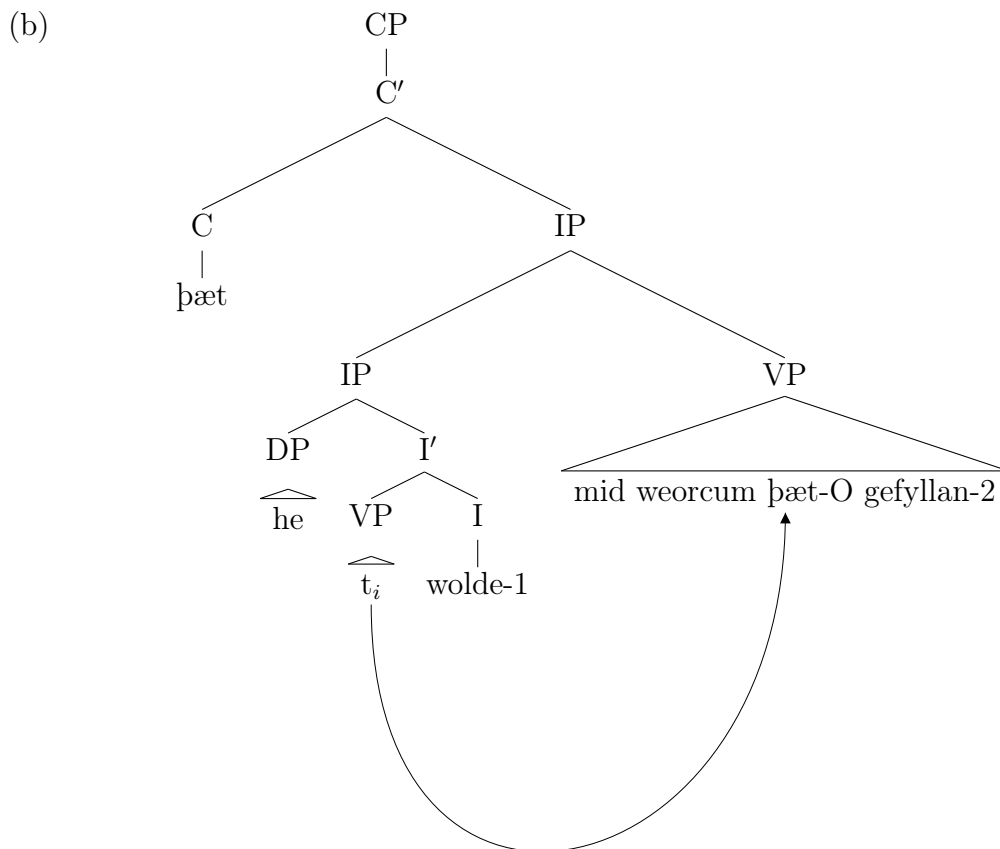

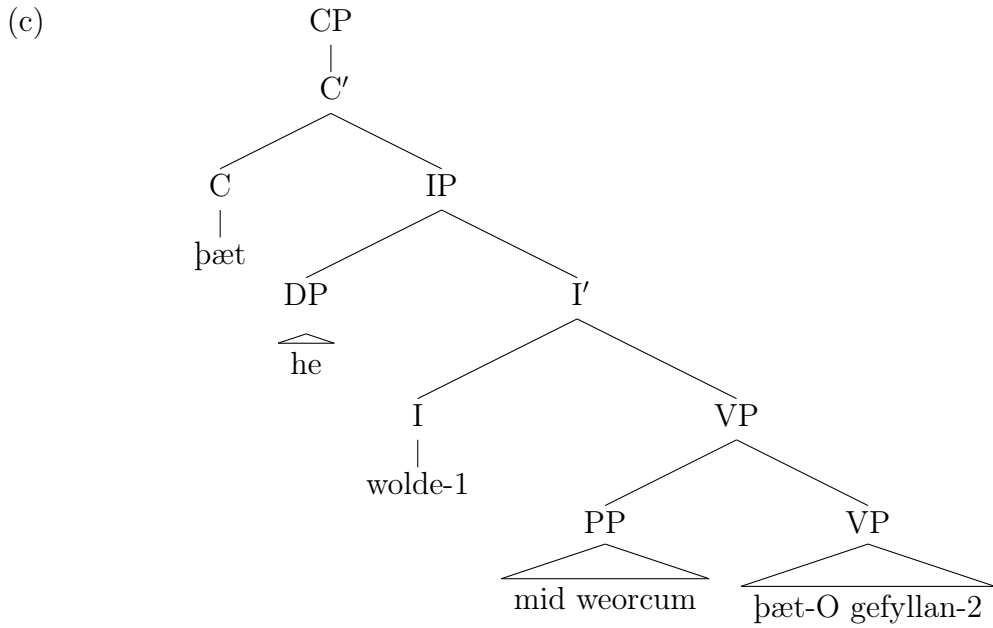

(3.8) (a) O V Aux

*...þæt he eallu þing gehealdan wille*  
 that he all things-O keep-2 wants-1  
 'that he wants to keep all things'  
 (cobenrul,BenR:58.99.8.1047)

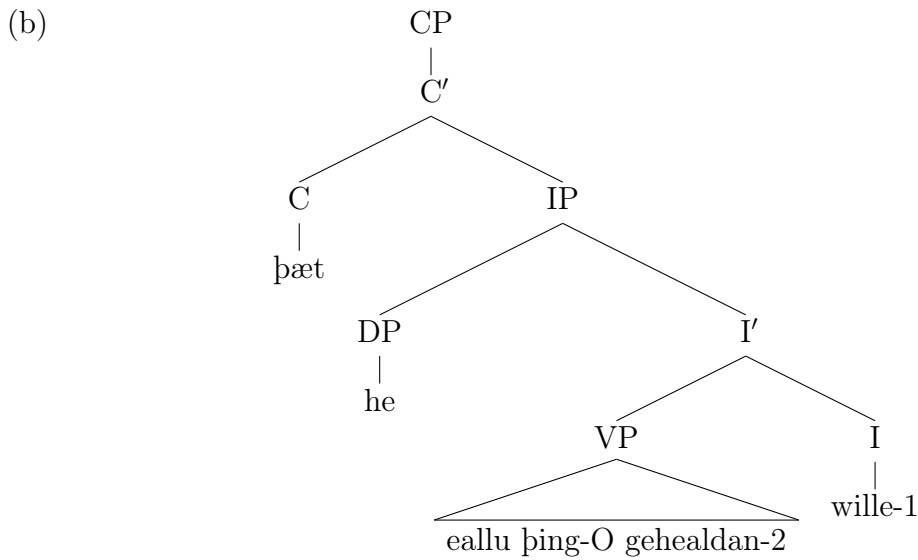

not have been base-generated in the positions they have in these sentences.

Given these various possibilities, it quickly becomes apparent that the competing grammars theory could generate the unattested order V O Aux by allowing a head-final IP with a VO verb phrase. Pintzuk (1999, 117) writes: “I have no explanation at this time for the relationship between the underlying positions of INFL, the head of IP, and V, the head of VP.” She later notes (Pintzuk, 2005, 136): “The only problem that the Head Parameter account faces is that a stipulation is required to block the derivation of V-O-Aux constituent orders.” The stipulation is that head-final IP’s cannot co-occur with VO verb phrases. To find a more elegant explanation for why this structure does not occur is one of the goals of my analysis of Old English.

The failure to account for the absence of the reverse brace construction is not the only issue with the competing grammars account of Old English. Example 3.9 was explained by verb raising of the non-finite verb to the position to the right of the finite verb. A verb cluster is formed. This predicts that elements should not be able to intervene between the finite verb and the raised main verb. But this prediction is incorrect: elements regularly intervene between the finite verb and the nonfinite verb provided that the finite verb comes first—including in constructions that are explained as VR by the competing grammars theory. See the example below:

- (3.11) *þæt Drihten hine mihte eft aweccean*  
 that Lord him-O might-AUX later awaken-V  
 ‘...that the Lord might wake him again’  
 (coblick,HomS\_21\_[BlHom\_6]:77.192.963)

While *eft* above is a relatively light element, even full phrases can intervene between the non-finite verb and the finite verb provided that the finite verb comes first:

(3.9) (a) O Aux V

...forhwy swa rihtwis dema ænige unrihte gife wille forgifan  
 why such just judge any unjust gift-O wants-AUX give-V  
 ‘why such a just judge would give any unjust gifts’  
 (coboeth,Bo:38.119.26.2383)

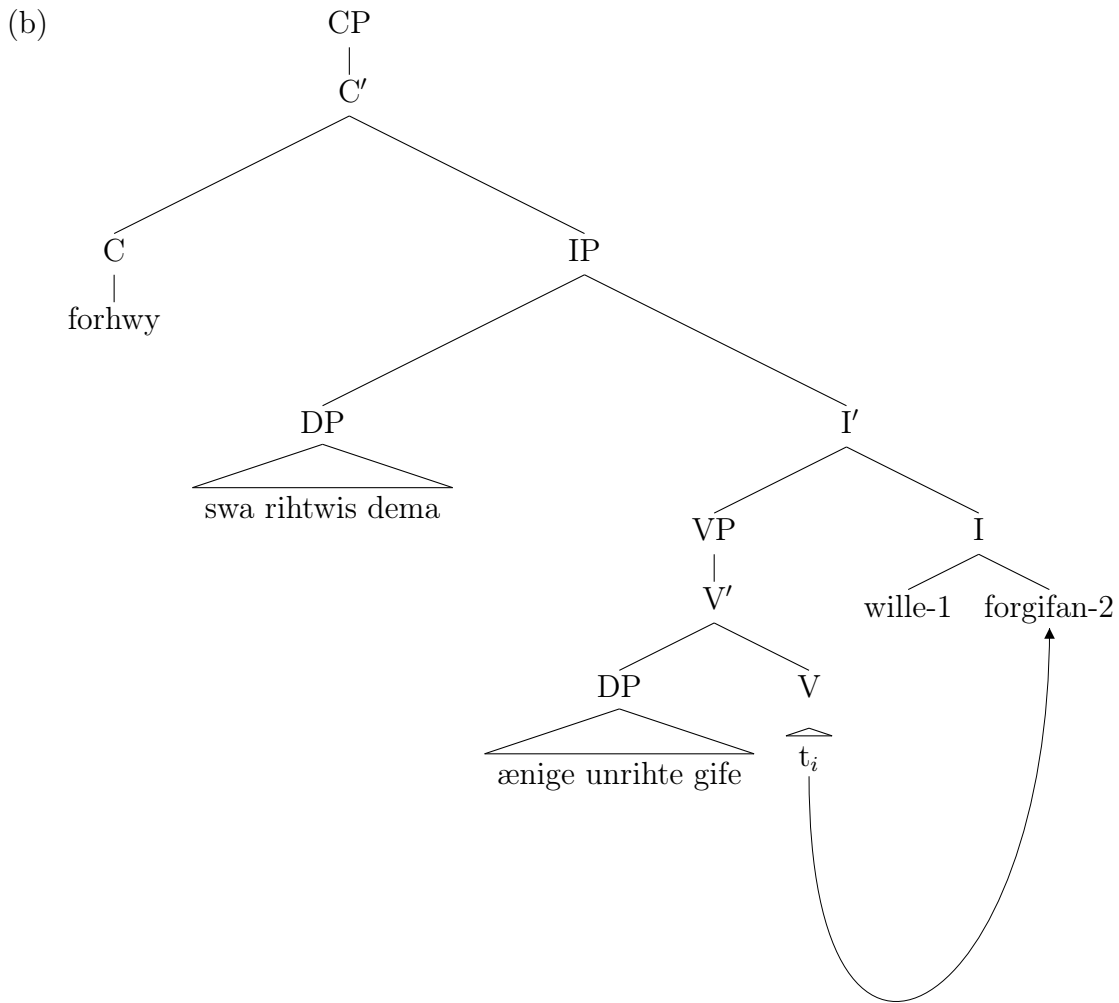

(3.10) (a) V Aux O

...*þæt Chyron centaurus findan-2 sceolde-1 þas wyrta-O...*  
 that Chyron centaur find-2 should-1 the plants-O  
 ‘that Chyron the centaur should find the plants’  
 (coherbar,Lch\_I\_[Herb]:36.0.789)

(b)

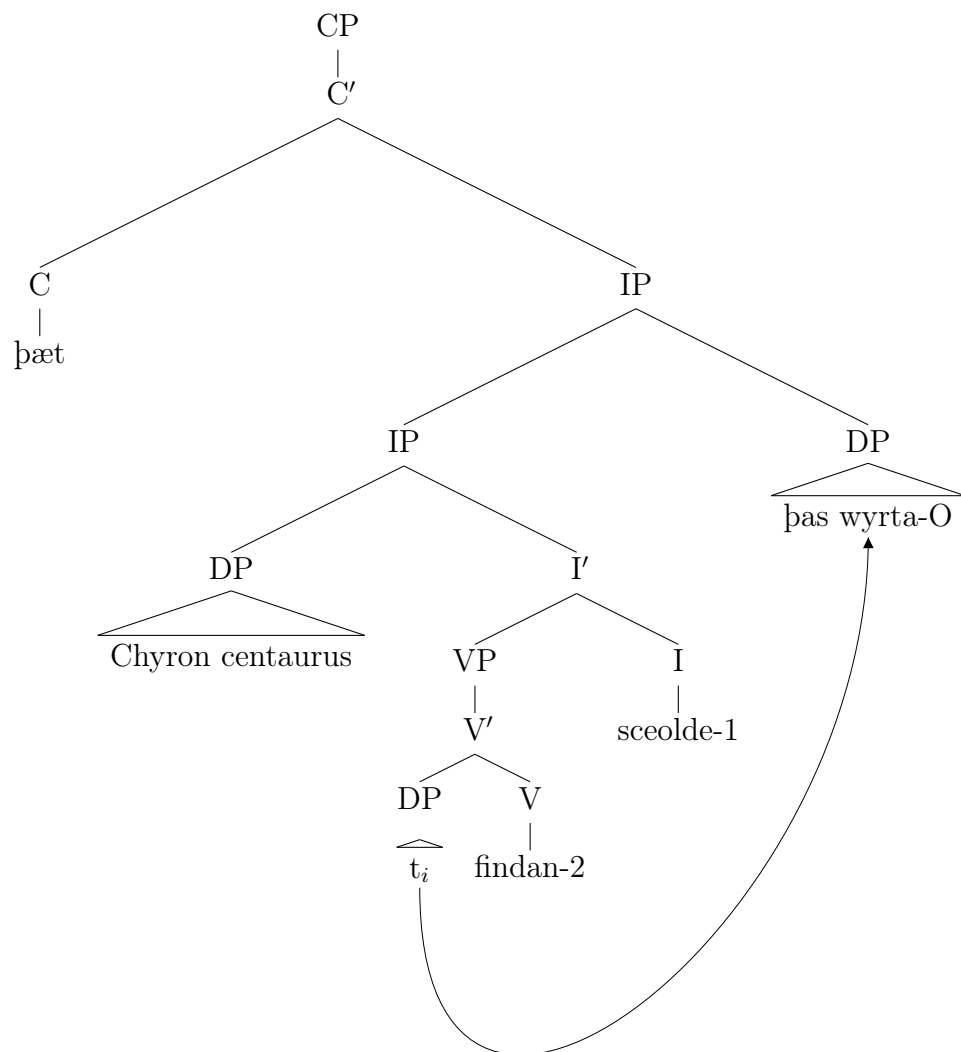

- (3.12) *þæt he hine moste of ðære rode adon*  
 that he him-O must-AUX of the cross take away-V  
 ‘that he must take him away from the cross’  
 (coverhomE,HomS\_24.1\_[Scragg]:357.344)

Another issue faced by a competing grammars account is its assertion that Old English is by and large a V2 language and that instances of non-V2 order in root clauses can be explained by head-final IP’s. But how to explain a root clause that apparently violates V2 but is necessarily a head-first IP according to head-first vs. head-final diagnostics proposed by Pintzuk and Haeberli (2008)? For instance, take the sentence used as an example by Pintzuk (1999, 136):

- (3.13) *hiora untrymnesse he sceal ðrowian on his heortan*  
 their weakness-O he shall-AUX atone-V in his heart  
 ‘He shall atone in his heart for their weakness.’  
 (CP 60.17)

Because of the position of the finite verb, this IP is necessarily head-first. Understanding how this sentence is V2 by the competing grammars theory requires understanding the idea of pronominal cliticization proposed in Pintzuk (1999, 187), which proposes that pronominal subjects and pronominal objects are syntactic clitics that can attach to “either the left or the right periphery of the first constituent of their domain: IP for pronominal subjects, pronominal objects, and adverbs; IP, VP, or PP for pronominal objects of prepositions.” In Example 3.13, the object *hiora untrymnesse* occupies the topic position in Spec,IP. As a clitic, *he* is merely attached to the periphery of Spec,IP. Thus, the finite verb still appears in second position.

The notion that cliticization can explain as V2 certain clauses that appear to be V3 or even V4 is quite popular in Old English linguistics literature. Recent work, however, has cast doubt on this theory. Pintzuk and Haeberli (2008) identify a number of diagnostic elements—negative objects, pronominal objects, stranded

prepositions, and particles used with verbs—that they claim can be used to determine whether an IP is head-final or head-initial. They present evidence that these elements cannot move rightward in a clause, and, as a result, these elements necessarily *precede* the finite verb in head-final clauses. If one of these elements comes after the finite verb, the IP cannot be head-final. Essentially, when V2 is violated, one of two conditions should apply:

- (a) One of the pre-verbal elements is a pronoun or an adverb and acts as a clitic, and V2 is not actually violated.
- (b) The clause is head-final.

Pintzuk and Haerberli find many clauses, however, in which two or more heavy elements precede the verb *and* in which the position of the so-called “diagnostic elements” make it impossible for the clause to be head-final. For instance:

- (3.14) *æfter þan se ðe gilty beo bidde him forgifnysse*  
 after that he who guilty is asks him forgiveness  
 ‘After that, the guilty one asks him forgiveness.’  
 (cochdrul, ChrodR\_1:16.36.321) [SOURCE: Pintzuk and Haerberli (2008, 402)]

The prepositional phrase *Æfter þan* as well as the subject appear before the finite verb. The clause is necessarily head-initial by Pintzuk’s theory. However, she claims that the object *him* cannot move rightward and thus must have been base-generated after the I position. Thus, V2 appears to be genuinely violated—even in head-initial IP’s. This is a phenomenon unexplained by the competing grammars account.

Indeed, even partisans of movement-based accounts of syntax admit that Old English poses numerous difficulties because all-head-final accounts as well as all-head-initial accounts fail to account for all the possible constructions without excessive stipulation. In the competing grammars account, the reverse brace construction is difficult to disallow without stipulations without also disallowing other

valid constructions. The V2 constraint necessary to explain much of the constituent movement is inconsistent, and the placement of the subject is not clearly defined. As a result, in the remainder of this work, I will turn towards a nontransformational, constraint-based account of OE: LFG.

# Chapter 4

## Introduction to LFG for Old English

### 4.1 The basics of LFG

As I have argued throughout the previous section, much of the difficulty associated with attaining an adequate generative account of Old English arises from the need to posit complicated movements to derive diverse word orders from one deep structure. By rejecting movement, LFG obviates the need for such explanations. Specifically, LFG posits different levels of *representational* structure to represent different aspects of *linguistic* structure.<sup>1</sup> The crux of LFG is that phrasal structure and grammatical function are represented separately in different projections that are then mapped onto each other.

Phrasal structure is represented by constituent structures, more commonly known as c-structures. These resemble the x-bar theoretic trees of transformational theories of grammar. For instance, the c-structure of the simple Old English clause *se cyning bræc þone stan* ‘the king broke the stone’ can be represented as below:

---

<sup>1</sup>The following discussion of LFG is based largely on Dalrymple (2001), Bresnan (2001), and Falk (2001).

(4.1)

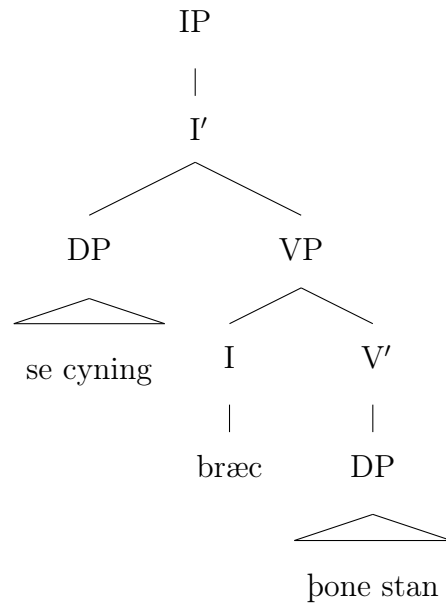

Note that the VP can appear without its V head. Moreover, optional phrases are allowed—like the object DP which would not appear with an intransitive verb. This tree is constructed from a series of annotated phrase-structure rules that define the allowable constituent structure of a clause along with any constraints that the phrasal constituent must satisfy. In this case, the (abbreviated) relevant rules would be:

(4.2) LFG Rules

$$\text{IP} \rightarrow \begin{array}{c} \text{DP} \\ (\uparrow\text{SUBJ}) = \downarrow \\ (\uparrow\text{CASE}) =_c \text{NOM} \end{array} \quad \begin{array}{c} \text{I}' \\ \uparrow = \downarrow \end{array}$$
$$\text{I}' \rightarrow \begin{array}{c} \text{I} \\ (\downarrow\text{TENSE}) \end{array} \quad \begin{array}{c} \text{VP} \\ \uparrow = \downarrow \end{array}$$
$$\text{VP} \rightarrow \left( \begin{array}{c} \text{V} \\ \uparrow = \downarrow \end{array} \right) \left( \begin{array}{c} \text{DP} \\ (\uparrow\text{OBJ}) = \downarrow \end{array} \right)$$

The down arrow indicates the f-structure of the current node. The up arrow indicates the f-structure of the current node's mother. The tree is populated with lexical elements that are stored in the lexicon with their own annotated rules. For

instance, the DP *se cyning* would be stored with the features represented in 4.3 and 4.4:

(4.3) *cyning*                   (↑PRED) = ‘king’  
                                      (↑CASE) = {nom|acc}  
                                      (↑NUM) = singular  
                                      (↑PERS) = 3.

(4.4) *se*                         (↑CASE) =<sub>c</sub> nom  
                                      (↑NUM) =<sub>c</sub> singular  
                                      (↑PERS) =<sub>c</sub> 3.

That is, when they come together, *se cyning* contains the information that can be paraphrased “my case is nominative, my number is singular, and I am third person.” The PRED value is an important component of LFG insofar as it provides the information necessary to construct the argument structure. If *cyning* were accusative rather than nominative, it would not be able to appear where it does in the c-structure because the Spec, IP c-structure position is constrained for a nominative DP. The lexical entry for the verb *bræc* would be something like the following simplified entry:

(4.5) *bræc*                   (↑PRED) = ‘break <(↑SUBJ)(↑OBJ)>’  
                                      (↑TENSE) = present  
                                      (↑SUBJ NUM) = singular  
                                      (↑SUBJ PERS) = 3.

The interpretation of the up and down arrows relies on the function  $\varphi$ , which maps from the c-structure phrasal tree to the functional structure: the f-structure. The f-structure represents grammatical relations like subject and object as well as features like case, person, number, and so forth. It is conventionally represented as an attribute-value matrix—like this one for the word *cyning* as in 4.6:

$$(4.6) \left[ \begin{array}{ll} \text{PRED} & \text{'king'} \\ \text{CASE} & \text{nom} \\ \text{PERS} & 3 \\ \text{NUM} & \text{singular} \end{array} \right]$$

Because of the phrase structure rules, we know that the f-structure of ‘cyning’ is the subject of ‘break.’ As a result, it will appear as SUBJ within the larger clausal f-structure as in Example 4.7:

$$(4.7) \left[ \begin{array}{ll} \text{SUBJ} & \left[ \begin{array}{ll} \text{PRED} & \text{'king'} \\ \text{CASE} & \text{nominative} \\ \text{PERS} & 3 \\ \text{NUM} & \text{singular} \end{array} \right] \\ \text{PRED} & \text{'break'} \langle \langle (\uparrow\text{SUBJ}) (\uparrow\text{OBJ}) \rangle \rangle \\ \text{TENSE} & \text{past} \\ \text{OBJ} & \left[ \begin{array}{ll} \text{PRED} & \text{'stone'} \\ \text{CASE} & \text{accusative} \\ \text{PERS} & 3 \\ \text{NUM} & \text{singular} \end{array} \right] \end{array} \right]$$

The verb contributes the PRED value for the sentence, and the functional information  $\langle (\uparrow\text{SUBJ}) (\uparrow\text{OBJ}) \rangle$  indicates that the f-structure of the mother node must contain a SUBJ and an OBJ. These grammatical relations are created in the c-structure by the annotations on the phrasal categories. To paraphrase, the IP is composed of a DP which states “I am my mother node’s subject,” and the VP has a DP which states “I am my mother node’s object.” The default annotation  $\uparrow = \downarrow$  means “I am identical to my mother node.”

A clause is only well-formed when the f-structure is neither incomplete nor incoherent. For instance, if the verb is like *break* and takes both SUBJ and an OBJ, the sentence “the king breaks” would be malformed because there is no  $(\uparrow\text{OBJ})$  as required. It is incomplete. Similarly “the king breaks the stone the tree” is

ungrammatical because it has two objects and the verb licenses only one. It is incoherent.

The ability to separate phrasal structure from grammatical function has a powerful effect on the efficacy with which Old English can be analyzed in that sentences with quite different constituent order can be analyzed with the same f-structure. For instance, consider Examples 4.8 and 4.9.

(4.8) *se cyning sceolde brecan þone stan*  
the king should break the stone  
'the king should break the stone'

(4.9) *se cyning þone stan sceolde brecan*  
the king the stone should break  
'the king should break the stone'

They have different constituent order. The exact structure of the phrasal structure will be explained in much more detail later in this paper. But their f-structures are identical because the grammatical functions of the lexical items are identical. The verb *brecan* still licenses a subject and an object. The auxiliary verb *sceolde* still licenses a subject and an XCOMP (a term used in LFG to refer to an open complement) and is associated with a rule that states that its subject is the subject of its XCOMP:  $(\uparrow\text{SUBJ}) = (\uparrow\text{XCOMP SUBJ})$ .<sup>2</sup> This elegantly captures the phenomenon of subject raising by showing that the subject of *sceolde* is also the subject of *brecan*.

---

<sup>2</sup>There is ongoing debate in the LFG literature as to whether auxiliaries should be represented with their own PRED value and their own complements (like raising verbs) or whether they merely contribute a syntactic feature. Falk (1984) influentially argues for a biclausal treatment for English auxiliaries. Butt et al. (1999) argue for a monoclausal structure for auxiliaries in which the auxiliary merely contributes tense and aspect features. Modals, however, can still receive the biclausal treatment even in this account if we assume that they pattern more like raising verbs than auxiliaries. Falk (2003) proposes different treatments for different auxiliaries. For instance, *do*, *be*, and certain modals would be feature-carriers whereas other modals and progressive *be* would have PRED values. The situation becomes complicated quickly. For the purposes of this paper and Old English, it will suffice to treat all auxiliaries as if they have their own PRED values. The analysis would be little changed if they were instead to be mere feature contributors in a monoclausal structure.

(4.10)

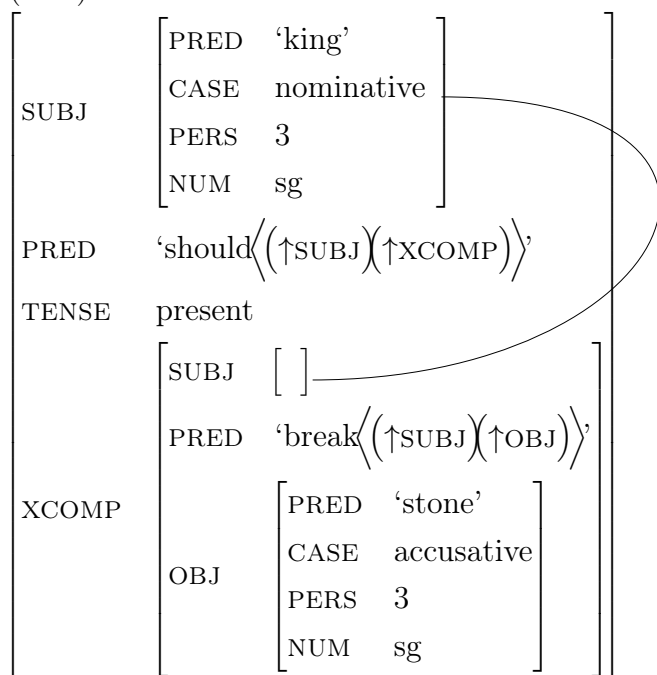

As we will see, c-structure and f-structure are among many possible projections available in LFG. There could also be structures associated with argument structure, semantic structure, and information structure. Dalrymple (2001), for instance, provides a model by which f-structure can be mapped onto semantic structure, called s-structure, through a function  $\sigma$ .

Because of the importance of information structure in Old English and its effects on word order, I will pay special attention to the possibility of a distinct projection for information structure. Information structure is the level of grammar that represents the informational status of various parts of a sentence—that is, whether a given constituent or constituents provides information that is new or old, prominent or not.<sup>3</sup> Butt and King (2000) propose a separate projection for information structure, projected from the c-structure nodes by the function  $\iota$ . They posit a

<sup>3</sup>For more on information structure in general, see e.g. Givón (1979), Andrews (1985), Lambrecht (1996), Butt and King (1997), and Dalrymple and Nikolaeva (2011 forthcoming).

TOPIC (old or known information that is relevant), FOCUS (new and prominent information), BACKGROUND INFORMATION (old information that shows how new information fits in), COMPLETIVE INFORMATION (new information that is not prominent). Because these features are not strictly syntactic, they should not appear in the f-structure. Having a separate projection will allow us to capture the insights of van Kemenade (1987) into Old English information structure and its effect on word order without making categorical judgments about the grammaticality of certain constructions. Accounts in which even discourse functions are determined purely by syntactic trees fail to capture this subtlety.

## 4.2 Clark's account of Old English

Clark (2004) offers one of most comprehensive examinations to date of OE in an LFG framework. That said, Clark's work is largely an effort to demonstrate the effectiveness of LFG with Optimality Theory (OT-LFG) as a means of analyzing and explaining language change. For my purposes, most relevant are Clark's proposals for an LFG account of OE. Clark proposes that OE clauses can be rooted either in IP or in an exocentric category S. IP must be head-initial, but the order within the VP can be either VO or OV. How then does he explain apparently head-final IP constructions? He posits that these constructions require the use of exocentric S along with a verbal cluster in which the non-finite verb precedes the finite verb.

Exocentric S is an unheaded syntactic category that need not adhere to X'-theory. It can dominate any number of lexical or phrasal projections. Austin and Bresnan (1996) famously posit S to explain the highly nonconfigurational word order of Warlpiri. But S has also been used to explain languages with far more constrained constituent order. For instance, Sadler (1997) uses S to explain the unusual VSO word order of Welsh, and Sells (1998) posits that S is available in

(4.11) Clark's trees

exocentric S

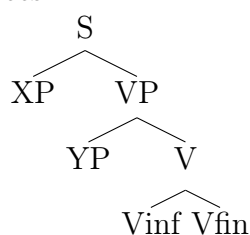

1-2 with VO

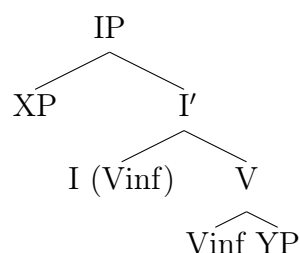

1-2 with OV

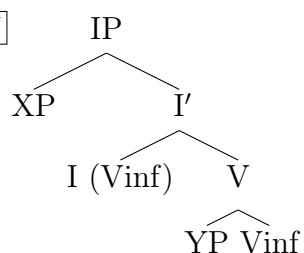

\*reverse brace

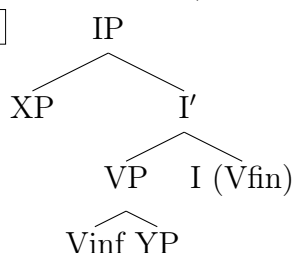

Icelandic.

Clark (2004) makes a similar proposal for the so-called “head-final” constructions in Old English. The absence of I-final constructions and the introduction of the exocentric S has an advantage over the transformational theories: it ensures that, whenever a licensing verb follows its complement, no elements can intervene. This makes the reverse brace construction impossible—which is precisely the result desired. 4.11 presents Clark's trees, where XP is the subject and YP a non-subject argument of the verb.

I, too, will assume that Old English makes use of exocentric S in certain constructions. But Clark suggests that his work “has just barely begun to scratch the surface of the syntax of verbal complexes in early English” (122). For instance, Clark (2004) implies that multi-headed verbal clusters in which the licensing verb follows the complement verb are necessarily rooted in S. The substantial presence of 1...3-2 (*should... broken be*) clauses, however, suggest the possibility of a multi-headed V existing within IP. That is, it seems probable that the finite verb is located in I, with the inseparable 3-2 verbal cluster appearing elsewhere. I will

argue that, because of the distribution of sentences with three verbal elements, it must be possible for S and IP to co-exist. The picture becomes further complicated by the common 3-2-1 order, in which no elements can intervene. This order raises the possibility of a triple-headed V. My own analysis will propose exactly such a structure handled using LFG’s notion of f-precedence.

As for the placement of the subject, Clark follows Pintzuk (1999) in proposing that pronominal subjects are non-projecting clitics that can appear either in Spec, IP or left-adjoined to the I head. Full DP subjects, meanwhile, can appear either in Spec, IP or in Spec, VP. This explains much of the limitation that we see in the placement of pronominal subjects. In Clark’s theory, adverbs and negative adverbs appear adjoined to VP. Thus, they can precede full DP subjects that appear in Spec, VP. But they cannot precede a subject in Spec, IP or attached to I—which is the only place that pronominal subjects can appear. Consequently, a sentence like 4.12 is possible, but 4.13 is not because the pronominal subject cannot appear in Spec, VP.

(4.12) *ne bræc na se cyning þone stan*  
 NEG broke NEG-ADV the king-SUBJ the stone  
 ‘the king did not break the stone’

(4.13) \**ne bræc na he þone stan*  
 NEG broke NEG-ADV he-SUBJ the stone  
 ‘he did not break the stone’

As in the competing grammars account, a higher level of structure, CP, is reserved for the special instances like interrogatives, *þa/þonne* pronouns, and negatives. Clark (2004, 201) proposes the tree in 4.14 as a “possible structure-function association.” The topic and focus positions in Spec, CP and Spec, IP are available to explain the marked orders in which the subject is not initial. The C head is reserved for the verb in questions, negatives, and *þa/þonne* clauses. Clark’s analysis explains many phenomena in Old English that are otherwise problematic.

(4.14) Clark (2004) tree

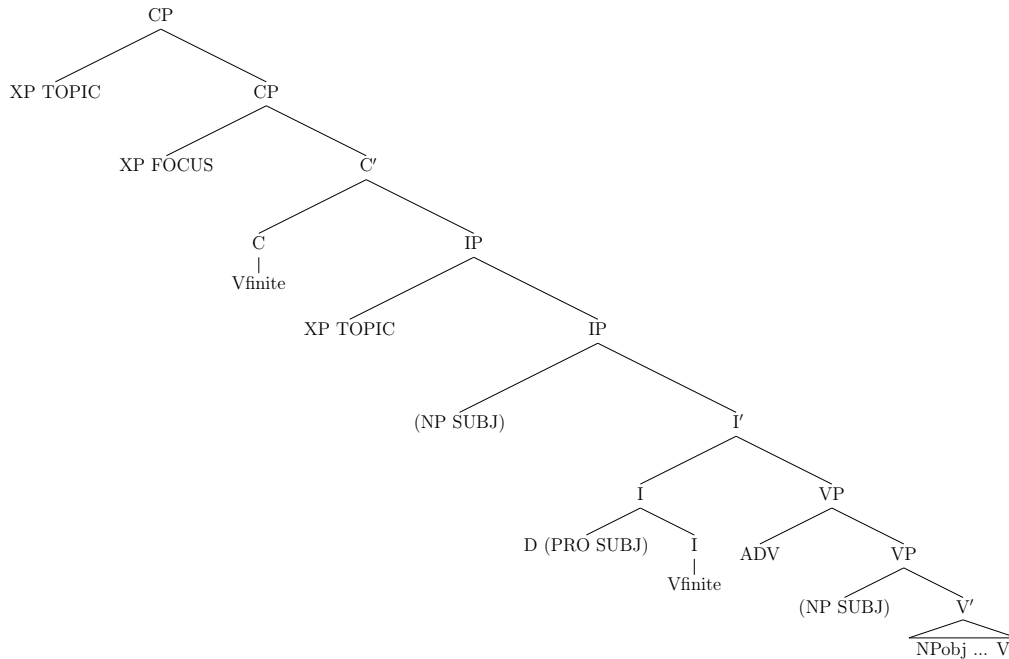

It is also worth noting that, because Clark focuses on testing the predictions of his OT-LFG approach and not on developing a comprehensive grammar, he considers the special placement of pronominal subjects only in IP's. By this analysis, if a finite auxiliary verb follows its verbal complement and it is not a C head, then the clause is rooted in S. Plenty of examples occur, however, in which a pronominal subject appears in a clause next to a verb cluster in which the finite verb follows the complement. Thus, pronominal subjects must be able to appear in S and not only in Spec, IP or attached to I because neither of those positions exists in the exocentric clauses.

Moreover, Clark's exocentric S tree seems to predict that, when the finite verb comes after the non-finite verb, it must appear at the end of a clause. Consider the two counterexamples in 4.15 and 4.16.

(4.15) *ƒ ofslagenne wurdon fela þæs folces mid færlicum*  
 and slain became much (of) the people with horrid  
*onræsum.*  
 attacks  
 ‘And many people were slain in horrible attacks’  
 (colsigewZ,æLet\_4\_[SigewardZ]:1231.615)

(4.16) *swa þonne nu mid him byrnan sceolan þa þe heora*  
 so then now with them burn should those REL-PART their  
*sylfra saula forhycggaþ*  
 self souls reject  
 ‘So then those that reject their own souls should now burn with them’  
 (coblick,HomS\_17\_[BlHom\_5]:63.142.765)

In both cases, the subject *follows* the verbal cluster. This cannot be explained by Clark’s exocentric model of such clauses in which the verb comes last:

(4.17) Exocentric tree

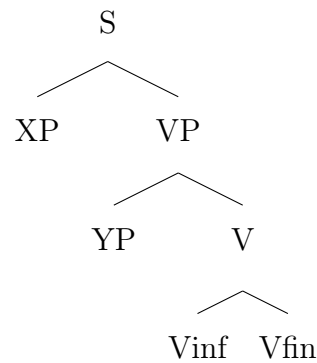

I will argue that, by allowing verbal clusters to appear in clauses rooted in IP, we can explain both these constructions as well as the problematic 1...3-2 order discussed above.

Another goal of my analysis will be to offer a theory rooted in LFG that accounts for the recent work by van Kemenade and others on the discourse effects of particles like *þa* and *þonne* as discussed in van Kemenade et al. (2008), van Kemenade and Los (2006), and van Kemenade (2009). This body of work convincingly

demonstrates that adverbs like *þa* and *þonne* could function in OE as “discourse partitioners” marking off new and old information. New information follows these markers, whereas old information precedes them. Showing that the discourse-linked area can be accounted for in an LFG approach, without recourse to multiple un-headed functional projections, will be the focus of Chapter 5. In doing so, I will depart from Clark (2004) by arguing that the discourse functions should not appear in the f-structure but in their own projection.

# Chapter 5

## Verbs and Verb Clusters

### 5.1 Introduction

Following Clark (2004), I propose that Old English allows multi-headed hierarchical verbal clusters. Understanding these verbal clusters will enable us to better understand why certain clauses are rooted in exocentric S rather than IP. And the entire picture of OE verb clusters presented here shows how certain fundamental functional relationships that exist among multiple verbs in a sentence can be maintained even with quite different word orders. That is, I show how multiple c-structures can give rise to the same f-structure. I follow Clark (2004) in suggesting that pressure against exocentric S may be responsible for much of the word order change in the history of English. But I will propose that it is largely a byproduct of the disappearance of the multi-headed verb clusters—which can exist both in S and in IP.

### 5.2 Verb clusters

When a complement verb precedes its licensing verb, Clark proposes a flat  $V_0$  cluster with two V heads. He justifies this cluster by arguing that it immediately captures

$$(5.1) \text{ (a) } V_0 \rightarrow \left( \begin{array}{c} V_0 \\ (\uparrow\text{XCOMP}) = \downarrow \end{array} \right) V_0$$

(b)

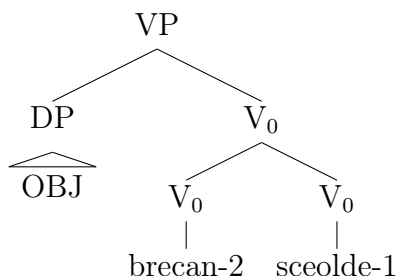

$$(5.2) \text{ (a) } V_0 \rightarrow \begin{array}{c} V_0^* \\ (\uparrow\text{XCOMP}) = \downarrow \end{array} V_0$$

(b)

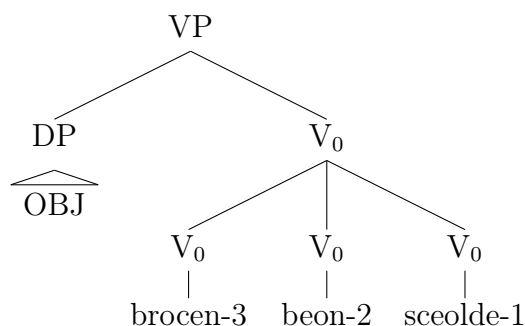

the inseparability of the verbal elements. That is, Clark's c-structure for a VP with a verb cluster is something like the rule and tree pairing shown in 5.1. The 5.1 structure breaks down, however, when there are three verbs in the cluster since there would be no way of determining the relationship among the verbal elements. With a rule and tree as in 5.2, the first two verbal elements would each claim to be the XCOMP of the mother node. This does not accurately capture the structural relationship by which each verb commands a complement that precedes it.

The problem could be solved by specifying that the verb's immediately preceding sister is its XCOMP. Although this is not unprecedented in the LFG frame-

(5.3) (a)  $V_0 \rightarrow \begin{matrix} V_0 & V \\ (\uparrow\text{XCOMP}) = \downarrow \end{matrix}$

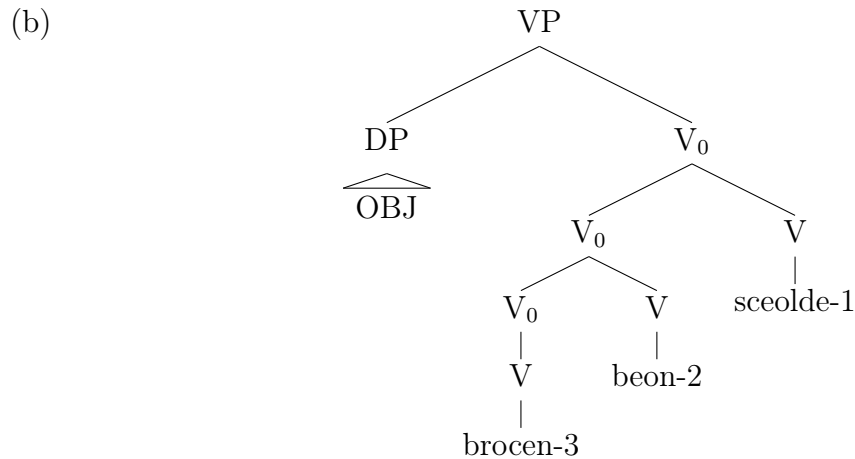

work, it is unnecessary in this instance. Instead, I will depart from Clark by proposing a hierarchical structure within the V head, as in 5.3.

This analysis captures the inseparability of the verbal cluster as well as the hierarchical XCOMP relationship among the verbal elements. The optionality of the recursive  $V_0$  step means that the same rule can apply to structures in which there is only one verbal element. We have now accounted for constraints on three verb constructions discussed previously. The verb clustering allows both 2-1 order (*break should*) and 3-2-1 order (*broken be should*) to occur and also captures the important fact that the verbs in these constructions must occur adjacently.

Clauses with three verbal elements offer the clearest examples of how this rule can be applied. The formation of verb clusters explains immediately the previously difficult-to-explain 1-3-2 verb order (*should broken be*). The finite verb occurs in I in a head-first IP just as we would expect. But, instead of a simple verb rooted in the VP, we find a 3-2 verb cluster that cannot be split, as in 5.4.

What happens, however, if such a verb cluster itself contains the finite verb?

(5.4) (a) 1 [...] 3-2

...*pæ̃t he mihte þar bediglad beon...*

that he might-1 there hidden-3 be-2

'that he might be hidden there'

(coapollo,ApT:11.1.182)

(b)

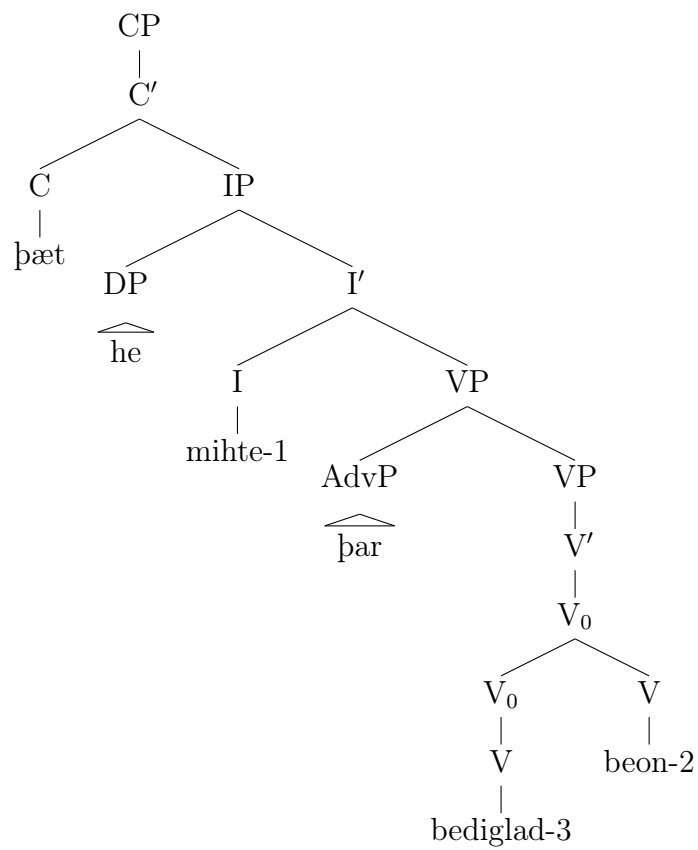

(5.5) (a) O V Aux

...þæt he eallu þing gehealdan wille  
 that he all things-O keep-2 wants-1  
 ‘that he wants to keep all things’  
 (cobenrul,BenR:58.99.8.1047)

(b)

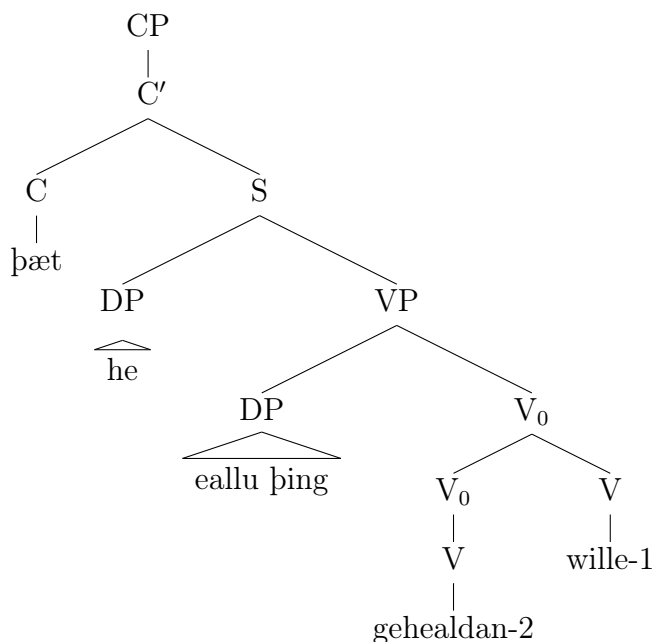

For instance, consider Example 2.9, repeated as Example 5.5.

The inseparability of the two verbs suggests that they form exactly the type of cluster suggested above. If so, however, there is no verbal element left to appear in the I head. A fundamental tenet of LFG is that functional categories are posited only when they are necessary and there is direct evidence for certain elements appearing in these positions. The evidence for a functional I-head in Old English arises from the fact that the finite verb typically appears outside the domain of the VP. When the finite verb appears as part of a VP-internal verb cluster, however, the evidence for IP in Old English disappears. As a result, a clause is rooted not

in IP but in S when the finite verb appears as part of a verbal cluster.<sup>1</sup>

This discovery allows us to declare IP categorically head-initial in Old English. A simplified unannotated version of the c-structure rule for IP would be something like:

$$(5.6) \quad \begin{array}{l} \text{IP} \quad \rightarrow \quad \text{XP} \quad \text{I}' \\ \text{I}' \quad \rightarrow \quad \text{I} \quad \text{VP} \end{array}$$

The rule for S would then be:

$$(5.7) \quad \text{S} \quad \rightarrow \quad \text{XP} \quad \text{VP}$$

where VP contains a verbal cluster with a finite verb. Both of these rules are quite simple, but neither allows the reverse brace construction (V O Aux) since it cannot be derived through head-final IP nor can it be derived from a verbal cluster. Importantly, unlike in the competing grammars account, the absence of the reverse brace construction follows from fundamental principles—that is, that IP is head-initial—and not from arbitrary stipulation.

1-2 (*should break*) and 1-2-3 (*should be broken*) constructions are handled as expected through the IP and embedded VP's, and there is evidence that finite verbal clusters could marginally appear in I from 2-1-3 (*be should broken*) order. That is, the 2-1 verbal cluster appears in I, and 3 appears in the V head in the VP. Because the appearance of a verb cluster in I is only marginally allowed, this construction is very rare in the corpus. When it does appear, however, the expected nonadjacency between 2-1 and 3 is indeed permitted:

---

<sup>1</sup>This restriction that I is obligatory in IP can be derived in part from Economy of Expression, as in Bresnan (2001, 90-92). That is, any c-structure nodes that do not contribute to the f-structure should be avoided. Another name for this is the principle of functionality of c-structure. See also fn. 3 below.

(5.8) 2-1 [...] 3

*...tæt ðær nænig wiht wyllsprynge beon mihte on gesewen.*  
that there not-any whit spring be-2 might-1 on seen-3  
'that not a whit of spring might be seen in it'

2-3-1 (*be broken should*) can never be permitted because, while the 2-3 component could form a verbal cluster, 2-3-1 cannot. Thus, the only possible analysis for 2-3-1 would be a verb cluster in VP with the finite verb in a head-final IP. But head-final IP is impossible. And this construction is entirely—and unsurprisingly—unattested.

This leaves only 3-1-2 (*broken should be*) order, which Pintzuk (1999) deems ungrammatical and Koopman (1990) deems marginally grammatical:

(5.9) 3-1 [...] 2

*ær hit geendad-3 mehte-1 beon-2*  
before it ended might be  
'before it might be ended'  
(coorosiu,Or\_5:11.125.19.2639)

In constructions like 5.9, which occur only 7 times in the corpus out of many hundreds of three-verb constructions, it seems possible that the participle is acting not as a verb but more as an adjective. The same sort of construction is marginally grammatical in PDE: "You dressed should be by 8:00." In this construction, *dressed* has a completive sense, and it seems a stretch to consider it part of a passive verbal construction. Similarly, I will not consider these few examples in the corpus enough to deem the 3-1-2 construction grammatical as a legitimate ordering of verbs.

The same type of structuring that applies to three verbs also applies to clauses with two verbs. When a licensing verb follows its complement with 2-1

(5.10) (a)

*se cyning sceolde brecan þone stan*  
 the king should break the stone  
 'the king should break the stone'

(b)

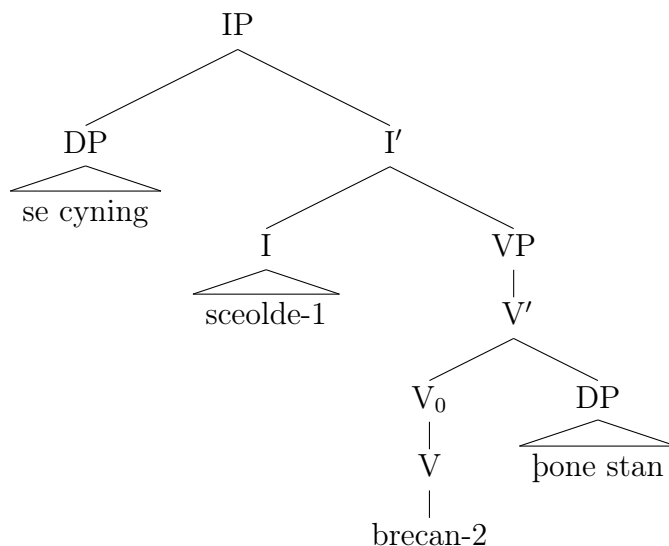

order, there is nothing to occupy the I head.<sup>2</sup> So the clause is rooted in S. When the order is 1-2, the normal IP structure applies. The f-structures, importantly, are the same for both types of clause. This shared f-structure is shown in 5.14. Consider the c-structures in 5.10 and 5.11. I' has an obligatory head-first I head that must be filled.

Besides being associated with just 5.10 and 5.11, the f-structure 5.14 is *also* associated with clauses that have OV order, as in Examples 5.12 and 5.13. In 5.11, the OBJ *þone stan* appears removed from its verb *breca*. But this is not a topicalized or otherwise special order. The sentence is analyzed by positing that the verb, modal, and object all appear within the VP. Thus, there is no I head and the clause is rooted in S. In Example 5.13, though, the finite verb can be in I and thus

<sup>2</sup>Note that, as I have acknowledged, it is possible that 2-1-3 order involves a 2-1 verbal cluster in the I head with the third verb appearing in VP. But this appears to be restricted to three-verb constructions and, even then, is quite rare.

(5.11) (a)

*se cyning brecan sceolde þone stan*  
 the king break should the stone  
 ‘the king should break the stone’

(b)

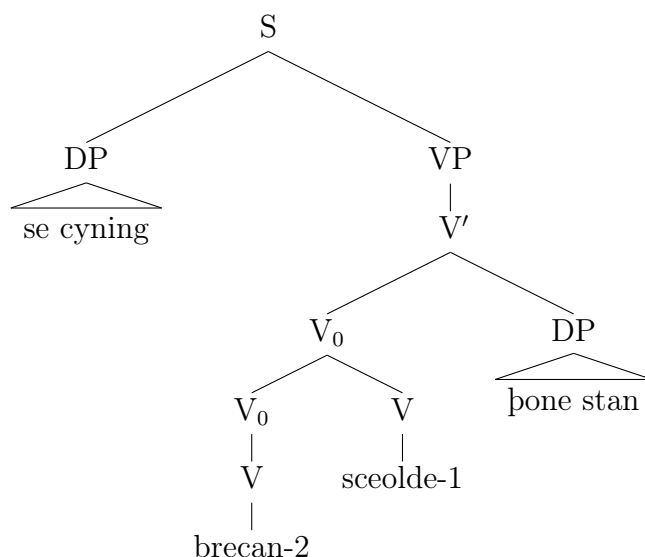

be part of an IP. Despite the differences in constituent order, the same f-structure corresponds to all four c-structures. This is the f-structure in 5.14.

There is some ambiguity as to whether a clause with only one verb is rooted in S or in IP since it can be difficult, perhaps impossible, to discern whether the verb is located in the I head or the V head. The sentence ‘se cyning bræc þone stan’ could be rooted in either S or IP and could thus receive two c-structures to correspond to one f-structure.<sup>3</sup>

In certain instances of clauses with one verbal element, it is possible to discern whether the clause is rooted in IP or S based on the placement of other constituent elements. For instance, it is widely assumed that negative adverbs

<sup>3</sup>There have been proposals, as in Frank (2002), that suggest that we could in fact choose between these two trees by Economy of Expression, where Economy of Expression involves counting nodes. In that case, S would be more desirable because it accounts for the same facts with fewer nodes. This does not necessarily coincide with the definition of Economy of Expression given in Bresnan (2001). But it does offer one appealing motivation for choosing S in the one-verb case shown here.

(5.12) (a)

*se cyning þone stan sceolde brecan*  
the king the stone should break  
'the king should break the stone'

(b)

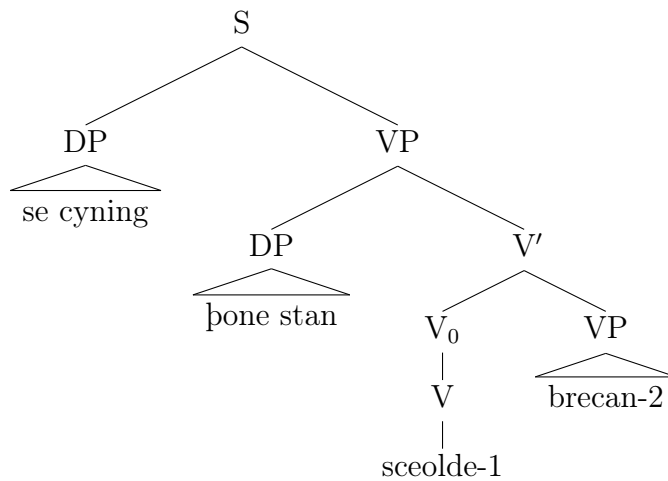

(5.13) (a)

*se cyning sceolde þone stan breca*  
the king should the stone break  
'the king should break the stone'

(b)

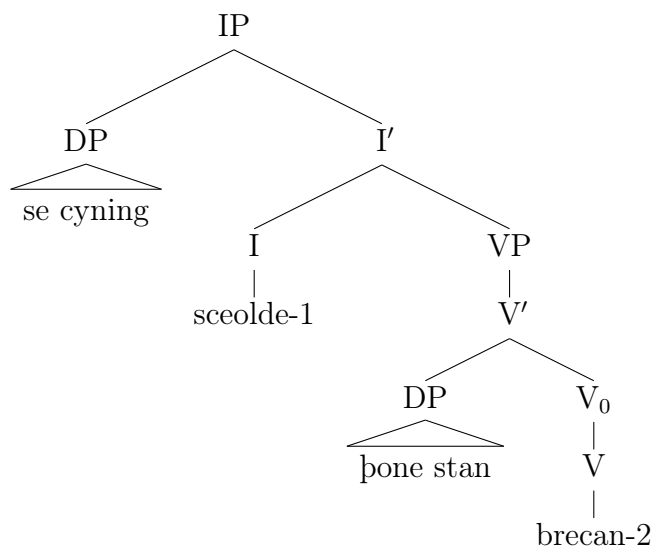

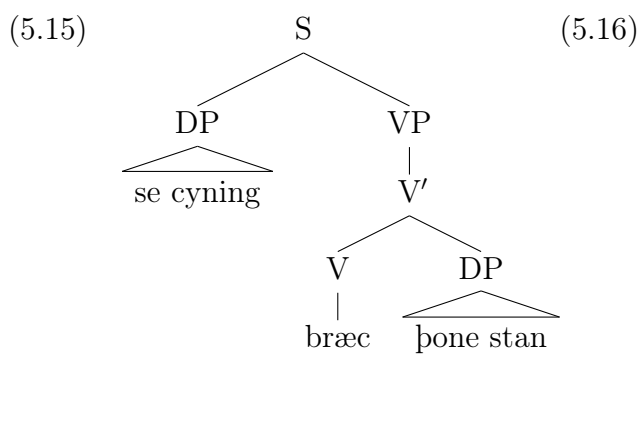
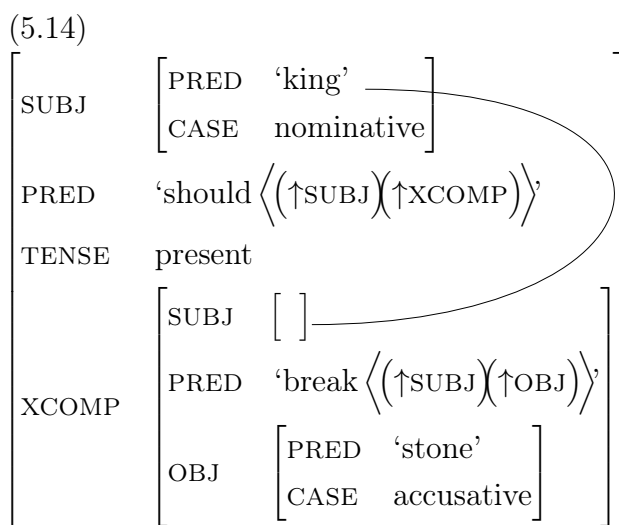

adjoin to VP in Old English. See, for instance, Rissanen (1998). Thus, a sentence like 5.18 below would necessarily have the tensed verb *outside* the VP, whereas 5.19 requires that the verb appear within the VP. This demonstrates that, as Pintzuk’s competing grammars account and Clark’s OT-LFG account both claim, there were in fact two fundamentally different types of clauses simultaneously available for OE speakers: S and IP.

The existence of the two clauses, and the eventual disappearance of exocentric S from English syntax, explains much of the history of English word order. It is perhaps exocentric S and its characteristic 2-1 verb clusters that are most notably absent when one compares the word order of OE to the word order of today’s

(5.17)

SUBJ	<table style="border-collapse: collapse; border: 1px solid black;"> <tr><td style="padding: 2px 5px;">PRED</td><td style="padding: 2px 5px;">‘king’</td></tr> <tr><td style="padding: 2px 5px;">CASE</td><td style="padding: 2px 5px;">nominative</td></tr> <tr><td style="padding: 2px 5px;">PERS</td><td style="padding: 2px 5px;">3</td></tr> <tr><td style="padding: 2px 5px;">NUM</td><td style="padding: 2px 5px;">sg</td></tr> </table>	PRED	‘king’	CASE	nominative	PERS	3	NUM	sg
PRED	‘king’								
CASE	nominative								
PERS	3								
NUM	sg								
PRED	‘break⟨(↑SUBJ)(↑OBJ)⟩’								
TENSE	past								
OBJ	<table style="border-collapse: collapse; border: 1px solid black;"> <tr><td style="padding: 2px 5px;">PRED</td><td style="padding: 2px 5px;">‘stone’</td></tr> <tr><td style="padding: 2px 5px;">CASE</td><td style="padding: 2px 5px;">accusative</td></tr> <tr><td style="padding: 2px 5px;">PERS</td><td style="padding: 2px 5px;">3</td></tr> <tr><td style="padding: 2px 5px;">NUM</td><td style="padding: 2px 5px;">sg</td></tr> </table>	PRED	‘stone’	CASE	accusative	PERS	3	NUM	sg
PRED	‘stone’								
CASE	accusative								
PERS	3								
NUM	sg								

(5.18) (a)

*se cyning ne bræc na þone stan*  
 the king NEG broke NEG-ADV the stone  
 ‘The king did not break the stone.’

(b)

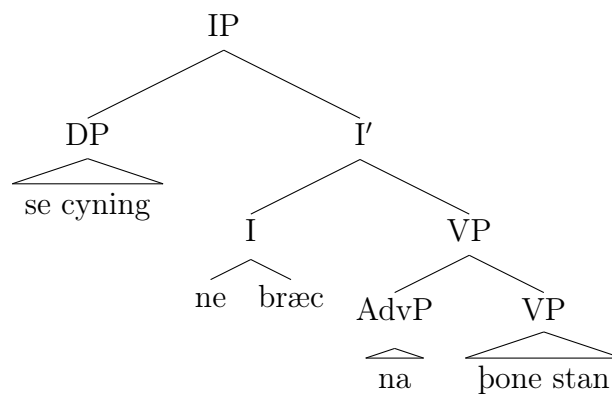

(5.19) (a)

*se cyning na ne bræc þone stan*  
the king NEG-ADV NEG broke the stone  
'The king did not break the stone'

(b)

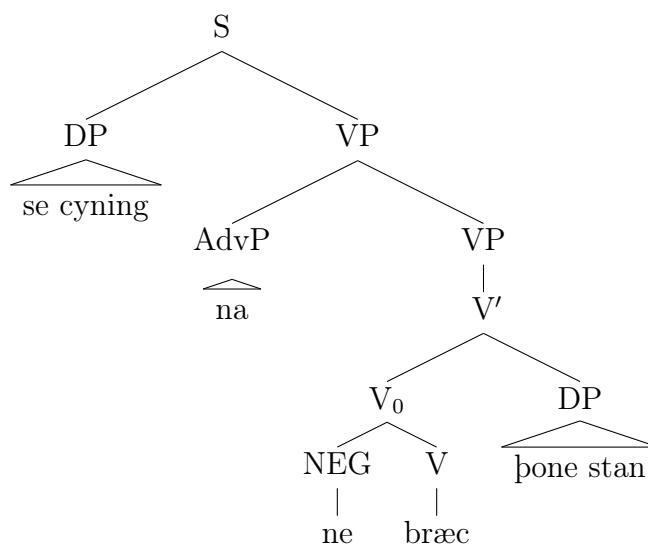

English. Clark (2004) offers an OT account that suggests that increased processing difficulty led to the disappearance of S. While this is a reasonable hypothesis, I would also like to see work on the processing difficulty associated with the 2-1 clusters. In these cases, when the object comes after the verb, the object can wind up appearing quite far from its licensing verb. Theories that rely on dependency length, like Tily (2010), suggest that this distance could entail significant processing costs. Without a careful and thorough understanding of how these verb clusters work in Old English, however, it is not possible to say anything meaningful about diachronic pressure.

In the next chapter, I will show how an LFG account of OE word order explains not only the placement of the verb but also OE information structure, negation, and the position of the subject. More importantly, though, I hope to have shown that the fundamental relationship of the c-structure and f-structure

can hold even among inseparable verbal clusters that otherwise appear to act as a single syntactic unit. The proposed hierarchical c-structure relationship among the  $V_0$  elegantly captures the hierarchical XCOMP relationship that we see in the f-structure.

## Chapter 6

# Information Structure and the Subject

The previous chapters focused largely on delving into the way that c-structure and f-structure share information in order to control the ordering of verbal elements in Old English. The placement of the subject varies in equally interesting ways but requires an approach that looks at more than just c-structure and f-structure. Specifically, we need to turn to information structure (i-structure).

As discussed in Chapter 1, pronominal subjects have a different distribution from full NP subjects. This alternation is especially clear when adverbs are involved. While most of the major generative studies have attempted to offer purely syntactic explanations for this fact, other recent work has posited that the data is best explained extra-syntactically using discourse functions. In this section, I will review both lines of inquiry and ultimately show how they can be reconciled in LFG using an information-structural approach. In doing so, I will join Mycock (2006), Dalrymple and Nikolaeva (2011 forthcoming), and others in proposing that discourse effects are not in a domain outside grammatical theory but can and should be handled through i-structure. That is, i-structure is an important, even integral,

part of modeling constituent order.

At the same time, we must be very careful about making categorical claims regarding information structure. Besides being extremely difficult to ascertain in a dead language like Old English, discourse constraints are not necessarily categorical. Bresnan et al. (2007), among others, show that whether a constituent is given or new can profoundly affect word order but that such constraints are better modeled probabilistically. Tily (2010) finds similar results for Old English. Thus, the LFG rules presented here should not necessarily be taken to be hard and fast constraints. That said, simply ignoring discourse factors would impede our ability to offer a complete analysis of constituent order, specifically in explaining subject position—which relies heavily on discourse effects and does at times seem to behave categorically. As such, it is important to make these i-structure rules explicit in a syntactic framework to whatever extent is possible.

## 6.1 Syntactic approach to subject position

As discussed previously, Clark (2004) proposes distinct locations for the subject with different restrictions for pronominal and nominal subjects. Specifically, he posits a lower level Spec, VP in which NP subjects can appear but in which pronominal subjects cannot. This analysis explains a broader trend by which subject pronouns, but not full noun phrase subjects, tend to precede the finite verb when the subject is not initial. For Clark, subject pronouns occupy a special non-projecting status distinct from full noun phrases.

First, let us examine the placement of the subject in IP-rooted clauses. Subjects can appear either in Spec IP or in Spec VP. As non-projecting elements, pronouns cannot appear in Spec VP but have to appear in the I head. Recall Clark's tree from 4.14 repeated below as 6.1.

(6.1) Clark (2004) tree

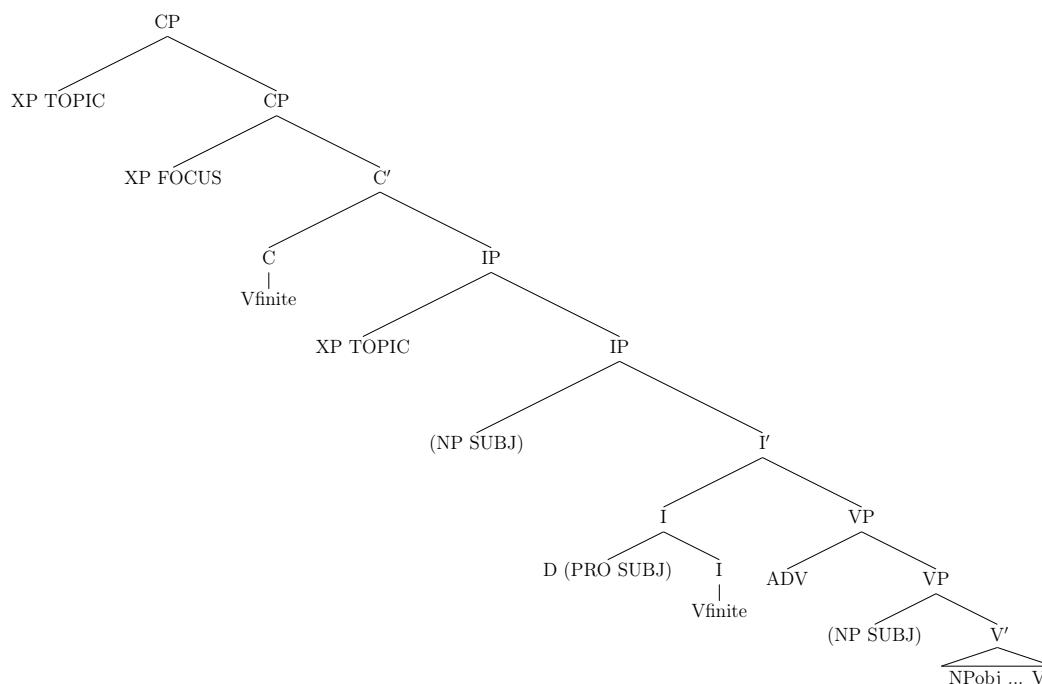

According to Clark (2004), evidence for determining the nature of such constructions comes primarily from examining clauses in which an object element is topicalized and clauses in which negative adverbs occur. When an element is topicalized and appears in Spec IP, the finite verb still necessarily appears in I. Thus, if the subject follows the verb, we know that it is in the VP domain as opposed to the IP domain. In general, pronominal subjects cannot appear in this domain. In the example that Clark cites from Koopman (1998), this generalization breaks down:

- (6.2) *Micel mæg heo æt hire bearne abiddan*  
 Much may-1 she at her child obtain-2  
 ‘Much may she obtain from her child...’  
 SOURCE: Koopman (1998, 137)

Clark notes that he finds several other counterexamples in the YCOE and explains them by writing, “It is more likely that the subject pronouns in these examples are functioning the same [grammatically] as full noun phrase subjects” (Clark, 2004,

175). Such a notion is problematic for the claim that pronouns occupy an inherently different status from full noun phrases in Old English.

A similar picture emerges when we examine the placement of negative adverbs with respect to the subject. As mentioned, the order PRONOMINAL SUBJ + NEG-ADV is permitted, whereas the order NEG-ADV + PRONOMINAL SUBJ is more or less unattested. Pronominal subjects must precede the negative adverbs. Because we assume the adjunction of NEG-ADV to VP, this data is consistent with the belief that a pronoun cannot occur as a subject in the VP projection.

(6.3) *ne mæg þæt na beon þæt...*  
NEG can that-SUBJ NEG-ADV be that...  
'it cannot be that...'  
(coblick,HomS\_47\_[BlHom\_12]:13114.1610)

(6.4) *\*ne bræc na he þone stan*  
NEG broke NEG-ADV he the stone  
'he did not break the stone'

The subject area to the right of the NEG-ADV is not one in which pronouns typically occur. Like the topicalization examples, however, there are exceptions, and it seems hasty to call it entirely ungrammatical.

Thus, the most that a purely syntactic account can tell us about the pronoun/full NP distribution in Old English is that pronouns usually behave as syntactically distinct from full NP's but sometimes don't. Pronouns generally do not appear after adverbs, but it is also not the case that the Spec IP position is reserved only for pronouns. It is clear that we must advance beyond the syntactic accounts of OE pronouns presented in van Kemenade (1987), Pintzuk (1999), and Clark (2004).

## 6.2 A discourse-based approach

A line of thought in opposition to the purely syntactic interpretation of pronouns argues that the difference in placement of pronouns and NP's results largely from discourse factors and not strictly syntactic ones, e.g. Hinterholz and Petrova (2010), van Kemenade et al. (2008), van Kemenade and Los (2006). Accounts like these rely on a notion of information structure, as in Halliday (1967), Lambrecht (1996), and Birner and Ward (2009). Information structure is defined as a “relationship between speaker assumptions and the formal structure of the sentence” whereby sentences undergo “pragmatic structuring according to ... utterance contexts” Lambrecht (1996, xviii). That is, pragmatic and discourse factors can play a role in the syntactic structure of the sentence. One of the main ways in which this occurs cross-linguistically is for certain structures to be distributed in different ways based on whether they convey new information, old information, important information, or background information.

What does this mean for Old English? It suggests that exactly such an account may be used to explain subject placement. By their anaphoric nature, pronouns tend to refer almost exclusively to old information. van Kemenade, Milicev, and Baayen specifically focus on sentences with the adverbs *þa* and *þonne* and posit that they act as discourse markers that separate new information (which comes after the markers) from old information (which precedes the markers). Thus, it is unsurprising that they rarely find the order *þa/þonne* + PRONOUN and instead find PRONOUN + *þa/þonne*. Through a multi-layered syntactic framework involving many functional projections, van Kemenade et al. (2008) propose that the high subject area is for pronouns and for definite nominal subjects, at least when the *þa/þonne* adverbs are involved in the construction. They note that OE did not have traditional definite articles but instead had weak demonstratives that could and often did refer to specific antecedents. As a result, they convincingly argue

that this discourse-linked area is reserved for old information—a category in which definite nominals could often comfortably fit in Old English. Consider the following examples from van Kemenade and Los (2006).<sup>1</sup>

(6.5) PRO SUBJ + PRO OBJ + *þa/þonne*

*He ne mihte swaþeah æfre libban, þeah ðe he hine þa*  
 He not could nevertheless ever live, though that he him then  
*ut alysede*  
 out released  
 ‘Nevertheless, he could not live forever, though he then released him’  
 (coelive, æLS[Ash\_Wed]: 119.2763)

(6.6) PRO OBJ + *þa/þonne* + DP SUBJ

*Gif him þonne God ryhtlice & stræclice deman wile.*  
 If him then God justly and strictly judge will.  
 ‘if God will then justly and strictly judge him’  
 (cocura, CP.5.45.20)

The first example shows both a pronominal subject and pronominal object to the left of the discourse markers. As pronouns, both *he* and *hine* represent old information. This is consistent with the claim that the area to the left of the adverbs is reserved for old information. Also noteworthy is the order: the subject pronoun precedes the object pronoun. This order is canonical and is rarely if ever violated when there are two pronouns that appear preverbally.

The second example also shows an object pronoun before the marker but has a full DP subject *after* the marker. This, too, is consistent. Recall, however, that object pronouns—unlike subject pronouns—can also appear post-marker, just as full DP subjects can also appear before the markers. How does this fit the

---

<sup>1</sup>When *þa/þonne* appear clause initially, they behave much like *wh-* words and cause the verb to appear immediately after them. This has discourse function effects consistent with other V-first constructions. There is further work to do on the c-structure status of these adverbs when they appear clause initially, but I will focus here mainly on clause-internal adverbs.

generalization? According to van Kemenade et al. (2008), the full DP subjects that appear prior to *ba/bonne* are necessarily old information. And the object pronouns that appear in the lower domain appear there because of their close relationship with the verb, despite their status as “old information.”

Exceptions can and do occur in this analysis. Discourse status is more fluid than pure syntax and not categorical in the same way. While pronouns are, by definition, always pronominal, it is possible to imagine sentences in which pronouns do not represent old information. And, indeed, van Kemenade et al. (2008) suggest that the pronouns that appear in positions typically reserved for full NP’s are in fact exceptional in that they are “subject to certain regularities” (12). They write: “Pronominal subjects following *ba/bonne* are either instances of the so-called Proposition-in-Focus, when the entire clause is given as new information focus ... or involve internal (object-like) nominative arguments” (12). Thus, these exceptional cases do not necessarily disprove the generalization that pronominal subjects cannot appear in the lower subject position.

In order to make their analysis work syntactically, however, van Kemenade et al. (2008) are forced to propose a number of functional projections, including AgrP for the discourse-linked area, NegP for the adverb particles, and a special scrambling phrase  $\Sigma$ P. Many of them are often empty, and the trees quickly become complicated. One major reason that van Kemeande et al. are forced into such an analysis is that a purely transformational approach to syntax requires shoehorning discourse and informational structure into trees best reserved for representing constituent structure. In the next section, I will present an LFG approach that handles the same data without recourse to these functional projections.

### 6.3 An LFG account of information structure

I will argue that, following Butt and King (1997), we can posit a separate informational projection or i-structure distinct from the f-structure and arrive at a clean and elegant LFG description of OE information structure and, as a result, of OE subject placement. By constraining the locations in which old and new information can appear, it is possible to explain the data effectively through an LFG account.

Before generalizing for OE clauses as a whole, I will first focus on the well-studied *þa/þonne* clauses and show how they can be treated in LFG. The LFG literature has differing opinions on how i-structure relates to other projections. Dalrymple and Nikolaeva (2011 forthcoming) posit that the i-structure is related to the semantic structure. Butt and King (1997) and Mycock (2006) both suggest that c-structure relates directly to both i-structure and f-structure and that i-structure and f-structure then interface with s-structure. For purposes of space and simplicity and without choosing theoretical sides, I will leave semantic structure implicit and simply allow c-structure to interface with i-structure. I will, however, follow Dalrymple and Nikolaeva (2011 forthcoming) and Butt and King (2000) by positing the four discourse function (DF) features TOPIC, FOCUS, BACKGROUND, and COMPLETIVE. TOPIC is associated with the features [-NEW] and [+PROMINENT], focus with [+NEW] and [+PROMINENT], completive information with [+NEW] and [-PROMINENT], and background information with [-NEW] and [-PROMINENT].<sup>2</sup> TOPIC and FOCUS will be the most important roles for the analysis of Old English.

van Kemenade and Los (2006), among others, show that the area to the left of *þa/þonne* is a prominent position and is associated with given information. In LFG terms, it is [+PROMINENT], [-NEW], and thus a TOPIC. This is associated

---

<sup>2</sup>These features are similar to those proposed by Choi (1996) but were modified by Butt and King.

$$\begin{aligned}
(6.7) \quad & \text{IP} \rightarrow \begin{array}{l} \text{DP}^* \\ (\uparrow\text{GF}) = \downarrow \\ (\downarrow\text{NTYPE}) \neq \text{pron} \\ (*_i\text{DF}) = \text{TOPIC} \end{array}, \left[ \left( \begin{array}{c} \hat{\text{D}} \\ (\uparrow\text{SUBJ}) = \downarrow \\ (*_i\text{DF}) = \text{TOPIC} \end{array} \right) \left( \begin{array}{c} \hat{\text{D}} \\ (\uparrow\text{OBJ}) = \downarrow \\ (*_i\text{DF}) = \text{TOPIC} \end{array} \right) \left( \begin{array}{c} \hat{\text{D}} \\ (\uparrow\text{OBL-GOAL}) = \downarrow \\ (*_i\text{DF}) = \text{TOPIC} \end{array} \right) \right] \text{I}' \\
(6.8) \quad & \text{S} \rightarrow \begin{array}{l} \text{DP}^* \\ (\uparrow\text{GF}) = \downarrow \\ (\downarrow\text{NTYPE}) \neq \text{pron} \\ (*_i\text{DF}) = \text{TOPIC} \end{array}, \left[ \left( \begin{array}{c} \hat{\text{D}} \\ (\uparrow\text{SUBJ}) = \downarrow \\ (*_i\text{DF}) = \text{TOPIC} \end{array} \right) \left( \begin{array}{c} \hat{\text{D}} \\ (\uparrow\text{OBJ}) = \downarrow \\ (*_i\text{DF}) = \text{TOPIC} \end{array} \right) \left( \begin{array}{c} \hat{\text{D}} \\ (\uparrow\text{OBL-GOAL}) = \downarrow \\ (*_i\text{DF}) = \text{TOPIC} \end{array} \right) \right] \text{VP}
\end{aligned}$$

with the Spec, IP position—which is typically in the position to the left of *ba/bonne* since those elements occur adjoined to VP. Following Clark (2004), OE pronouns are non-projecting elements in LFG. As in Toivonen (2003), I use the notation  $\hat{\text{D}}$  to indicate a non-projecting D. Furthermore, although I assume a non-projecting status for pronouns, the fact that D is also shared by demonstratives and definite articles is not relevant to the present discussion and we could just as easily consider pronouns to be projecting DP's. That gives us, in sum, the rules for IP and S displayed in 6.7 and 6.8. Note that this analysis does not necessarily assign the GF through the c-structure at all. Rather, the canonical S-first order may fall out of the fact that, as in Lambrecht (1994), subjects are default topics.

The IP rule states that a DP with any function, SUBJ, OBJ or OBL-GOAL, can occur in Spec IP provided that it supplies old and prominent information. The non-projecting pronouns  $\hat{\text{D}}$  can come either before or after the DP (if it exists), but their own linear order is determined by the c-structure constraint such that, if multiple pronouns occur, they occur in the order SUBJ OBJ OBL-GOAL. The DF function, which projects to the information structure level as indicated with the subscript  $i$ , ensures that each of the elements that occur in Spec IP represents old information. The comma indicates the possibility of scrambling whereby the order of the categories on either side of the comma can be switched. This allows a full NP to come before, among, or after any pronouns that appear in the same position

provided that the pronouns maintain their linear order if there is more than one. Rule 6.8 is a similar rule that works for the clauses rooted in S. It is identical to the IP rule except S dominates VP instead of I'.

It may be helpful at this point to consider the example above from van Kemenade and Los (2006), repeated below:

(6.9) PRO SUBJ + PRO OBJ + þa/þonne

*He ne mihte swaþeah æfre libban, þeah ðe he hine þa*  
 He not could nevertheless ever live, though that he him then  
*ut alysede*  
 out released  
 ‘Nevertheless, he could not live forever, though they then released him’  
 (coaelive, æLS[Ash\_Wed]: 119.2763)

Because the subject comes before the VP-adjoined adverb and the finite verb comes after, we know that the finite verb must be in the VP domain and cannot be in I. Because I is obligatorily filled whenever IP appears in Old English, the clause is rooted in S, as below:

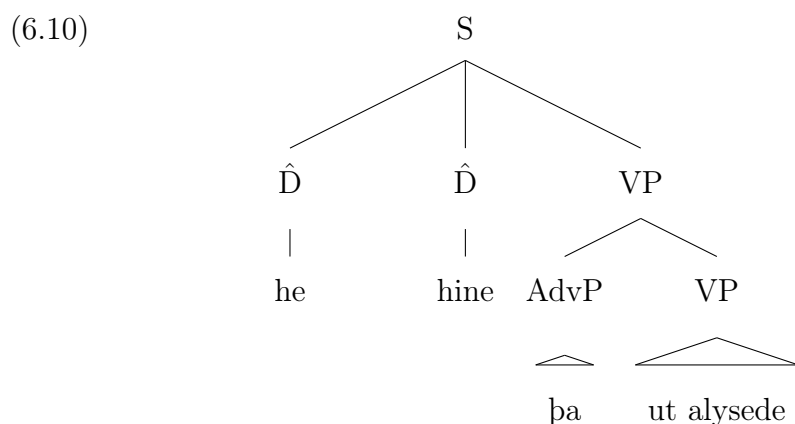

(6.11) i-structure:  $\left[ \text{TOP} \left\{ \begin{array}{l} \text{he} \\ \text{hine} \end{array} \right\} \right]$

The familiar grammatical functions like SUBJ and OBJ would appear in the f-

structure, but there is also an information structure projection that we have not previously represented. This is where TOPIC appears, as shown above in 6.11. For our present purposes, it is not necessary to fill out the rest of the i-structure with other discourse functions from the clause, although this is indeed possible in principle.

We can now investigate the other main subject position available: Spec,VP. Unlike Spec,IP, Spec,VP is typically reserved for new information. It is a FOCUS position. As a result, except in exceptional circumstances, pronouns do not appear in the Spec,VP position because they are generally [-NEW]. Note that Spec, VP can appear linearly either before *or* after V' in 6.12. The disjunction allows the possibility of a VP modifier to adjoin to the VP. I also allow for modification to occur at the V' level. There are cases in which only one of these two options for modification offers a coherent analysis, but the exact means of modification is not important for the discussion at hand.

$$(6.12) \quad \text{VP} \rightarrow \left\{ \begin{array}{l} \text{DP}^* \\ (\uparrow\text{GF}) = \downarrow \\ (*_i\text{DF}) = \text{FOCUS} \end{array} \right. , \quad \text{V}' \left| \begin{array}{l} \text{VP}_{\text{mod}} \quad \text{VP} \end{array} \right\}$$

Rule 6.12 is the rule at work in 6.13.

(6.13) PRO OBJ + *þa/þonne* + DP SUBJ

*Gif him þonne God ryhtlice & stræclice deman wile.*  
 If him then God justly and strictly judge will.  
 ‘if God will then justly and strictly judge him’  
 (cocura, CP.5.45.20)

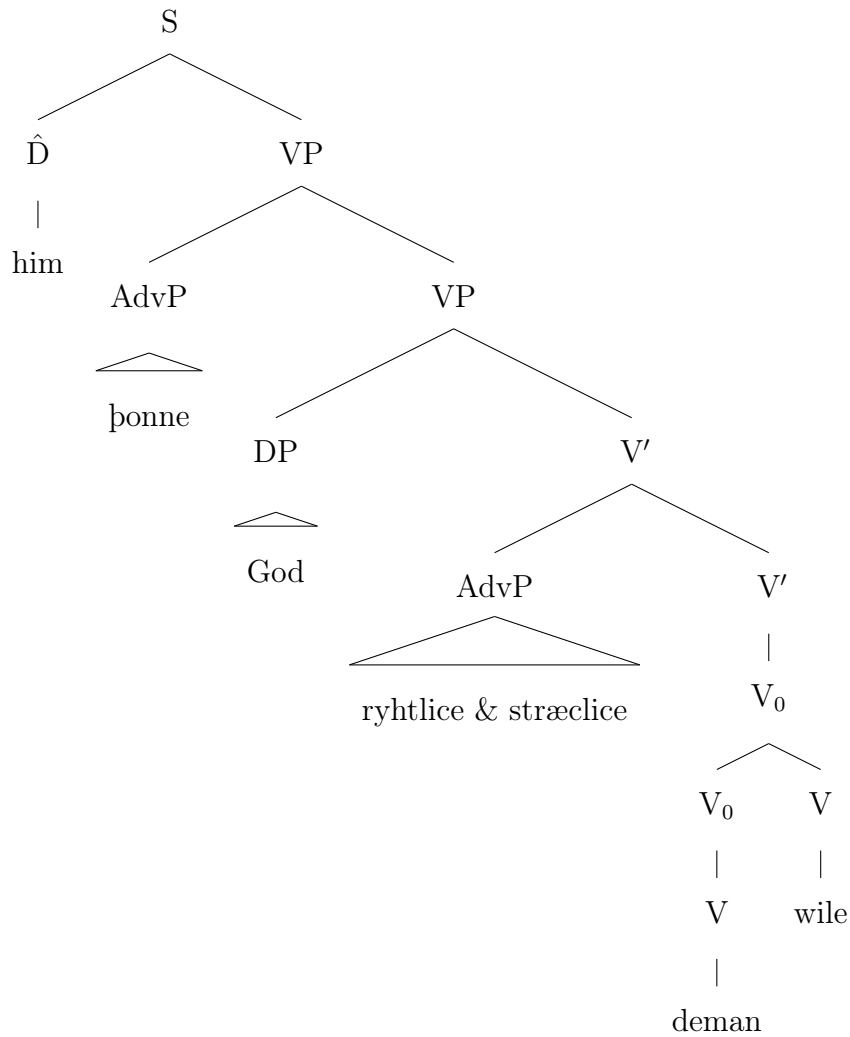

$$\text{i-structure: } \begin{bmatrix} \text{FOC} & \{ \text{God} \} \\ \text{TOP} & \{ \text{him} \} \end{bmatrix}$$

*God* is the FOCUS because it is new information as indicated by its position after the discourse marker. *Him* is a TOPIC because it is old information. Notice that this rule captures the correct distribution of pronouns and full nominals but avoids putting any i-structure information in the c-structure or f-structure.

The overall structure presented here of new versus given information fits with the claim in Bech (2001) and Westergaard (2005) that V2-order arises when the subject is new but V3 order happens when the subject is given. That is, the

order XP+V+SUBJ occurs with the verb in I and the subject in VP. The V3 order happens with a subject before the verb in I because the subject is old information and thus in Spec, IP. Thus, the mysterious “sometimes V2, sometimes not” nature of Old English is neatly explained by recourse to discourse functions.<sup>3</sup>

The rules created to handle clauses with *þa/þonne* adverbs can be extended to apply to Old English at large. For instance, the same set of generalizations can be applied to sentences with negative adverbs. Consider the examples below in 6.14-6.17, in which the subjects are in bold.

- (6.14) *þa se hælend þis gehyrde he sæde him ne beþurfon*  
 When the hero this heard he told them NEG need  
*na ða halan læces...*  
 NEG-ADV the hearty-SUBJ gift  
 ‘When the hero heard this, he told them [that] the hearty do not need help’  
 (cowsgosp,Mk\_[WSCp]:2.17.2307)

- (6.15) *Gyf hwa wyle nu swa lybban æfter Cristes tocyme, swa swa*  
 If who will now so live after Christ’s coming, as  
*men leofodon ær Moises æ oþþe under Moises æ, ne byð*  
 men lived before Moses’ law or under Moses’ law, NEG is  
*se man na cristen*  
 the man NEG-ADV Christian  
 ‘If a man will now live after Christ as men lived before Moses or under  
 Moses, the man is not Christian’  
 (coprefgen,æGenPref:20.16)

- (6.16) *ne mæg þæt na beon þæt þa bearn þe*  
 NEG can that-SUBJ NEG-ADV be that the children the  
*unbliþran ne syn...*  
 unhappier NEG are...  
 ‘it cannot be that the children are not unhappier’  
 (coblick,HomS\_47\_[BlHom\_12]:13114.1610)

---

<sup>3</sup>Still left unexplained is a strong tendency for pronouns not to occur after inseparable verb clusters.

(6.17) \*?ne bræc na he þone stan  
 NEG broke NEG-ADV he the stone  
 ‘he did not break the stone’

In the first sentence above, 6.14, the nominal phrase ‘ða halan’ occurs in the VP projection and as such is associated with the FOCUS position. This makes sense since ‘ða halan’ is not referenced in the preceding clause since the preceding clause merely describes the speech act whose content is revealed in the next clause.

In the second sentence, the subject is *se man* and associated with the TOPIC position. In 6.16 and 6.17, the subject is pronominal and consequently cannot be a FOCUS. The fact that ‘se man’ is directly linked to ‘hwa’ in the preceding clause makes explicit that it is not new information. Our theory correctly predicts that there are many examples like 6.16 in which the pronominal subject appears before the negative adverb and also that examples like 6.17, in which the pronominal subject comes after the adverb, are extremely rare if not non-existent.

That is not to say, however, that a pronominal subject can *never* appear in that position. If for some reason, a pronoun was to be used as new information, it could appear there. And indeed this happens with *þa/þonne* often enough that we simply cannot ignore it. Indeed, it is not clear to what extent discourse functions are categorical in the same way that other grammatical constraints are. While discourse constraints themselves seem highly gradient, the placement of the subject – a closely related problem – is largely categorical. How exactly to model this interaction is an area in which more research is needed.

Nonetheless, I believe that the LFG account of OE presented here, one that allows a flow of information from c-structure to i-structure, can serve as a framework for incorporating the insights of the recent statistical work by van Kemenade and colleagues into a non-transformational framework for analyzing Old English.

# Chapter 7

## Word Order Freezing

### 7.1 Introduction to word order freezing

Throughout the previous two chapters, the presence of different LFG projections and how they relate to one another has been at stake. I have argued that the c-structure projects two parallel paths to the f-structure and to the i-structure. Certain clauses have c-structures rooted in IP, whereas others are rooted in S. I have insisted on the importance of handling verb clusters in the c-structure. And I have argued that the constituent order and thus the c-structure is heavily influenced by the discourse functions represented in the i-structure. At the most basic level, it is this diversity of projections—as opposed to just trees—that allows LFG to explain Old English word order in a way that transformational accounts cannot.

In this chapter, I will examine what might happen when a usually free word order becomes constrained through a process called word order freezing—a process by which languages that allow variation in word order sometimes “freeze” constituent order in the absence of morphological cues. Russian, Dutch, and Japanese have all been claimed to show varying levels of word order freezing. It is highly difficult to ascertain whether Old English shared this property without access to speakers,

but some preliminary evidence suggests that it is a very real possibility. It is not immediately obvious how to build word order freezing into an LFG grammar since most types of word order freezing occur *only* in the absence of any other disambiguating information.

LFG, however, requires monotonicity, as described in Bresnan (2001) and Dalrymple (2001). This means that the function that maps the c-structure onto the f-structure can only accumulate. Thus, resultant f-structures become more and more specific as we add constraints. A complexity arises, however, when we try to specify that certain prohibited structures become prohibited only when there is no disambiguating information. That is, we wind up seeking to restrict possibilities that would ordinarily violate neither completeness nor coherence. Intuitively, this seems more like removing a rule—and violating monotonicity—rather than adding a restriction. But that need not be the case.

In proposing an LFG analysis of this complicated phenomenon, I will offer and compare two novel approaches: one within the traditional LFG framework and one that requires a variant of Optimality Theory within LFG in order to explain these phenomena. While the former has a certain appeal in its consistency with the basic tenets of LFG, including monotonicity, I argue that the latter offers desirable psychological reality. I will also turn to Lambrecht (1994) as part of an effort to link this word-order freezing effect to the broader information-structural constraints of the preceding chapter.

A great deal has been made of the fact that, as in Pintzuk (2002), the presence or absence of overt morphological case in OE has little effect on whether a given clause has OV or VO order. That said, a freezing effect does seem to occur when the case markings are ambiguous. This occurs with particular frequency when proper nouns are involved, as in 7.1.

(7.1) *And on þison gere ec swac Harðacnut Eadulf eorl under his*  
*And in this year also deceived Harthacnut Eadulf eorl under his*  
*griðe*  
 truce  
 And in that year Harthacnut also deceived Eadulf eorl in his truce  
 (cochronC,ChronC\_[Rositzke]:1041.6.1802)

Neither the subject nor the object is morphologically marked as nominative or accusative, but we know that *Harðacnut* is the subject and *Eadulf eorl* is the object because the subject generally precedes the object when case is ambiguous.<sup>1</sup>

Word order freezing is a phenomenon that has received increasing attention cross-linguistically. Bouma (2008, 2011) notes that in languages like Russian and Dutch, word order can vary freely unless case becomes ambiguous, at which point word order then steps in to determine how the clause should be interpreted. Tily (2010) discusses the phenomenon at length and points to Lee (2001) for Korean, Potts (2007) for Japanese, and Bouma (2011) for Dutch.

As I have suggested, word order freezing is a particularly tricky topic to get a firm grasp on, even in living languages. Let's take Dutch, for example. While Bouma and others see it as a clear effect, others have suggested that it does not exist at all or exists only very weakly. Conversation with native Dutch speakers suggests that Bouma's examples referenced below can be easily "unfrozen" through certain intonations much in the same way that a sentence like "Pizza Tom ate" is grammatical in English only in a very specific context with a very specific intonation. For example, imagine that sentence coming as a response to the question "Did Tom eat pizza?" If Tom ate a ton of pizza and the intonation is right, "Pizza Tom ate" would be perfectly grammatical. In a totally unmarked situation, however, it seems quite odd.

---

<sup>1</sup>As Bloom (1999) suggests, freezing effects in other languages are mitigated by intonation and emotive patterns. Unsurprisingly, no such phonetic data is available for Old English, but it is reasonable to assume that the same patterns apply.

Because we cannot ask Old English speakers these types of questions, we cannot be sure exactly to what extent word order freezing occurred. A full-blown statistical analysis may offer insight, but that is beyond the scope of this thesis. Rather, the crux of this chapter will be a formal analysis of how a phenomenon like Old English word order freezing can be handled in LFG.

## 7.2 Russian word order freezing in LFG

### 7.2.1 Bloom's account

Perhaps because of the differences presented above that result from monotonicity, word order freezing has received relatively little attention in LFG compared to other theories. Bloom (1999) provides an account of Russian word order freezing in standard LFG, and Lee (2001) proposes an account of freezing in an OT-LFG framework with a focus on Korean and Hindi. Before offering my own analysis, it will be useful to understand Bloom (1999) and its implications for Russian. Russian allows quite free word order to occur in transitive sentences since objects can be topicalized. Bloom (1999, 64) gives the following examples:

(7.2) (nominals morphologically distinct)

(a) *Mama*                    *ljubit* *papu*  
Mother-NOM loves father-ACC  
'The mother loves the father'

(b) *Papu*                            *ljubit* *mama*  
Father-ACC-TOP loves mother-NOM  
'The mother loves the father'

(7.3) (all nominals morphologically ambiguous between NOM and ACC)

(a) *Mat'*                    *ljubit* *doc*  
Mother-NOM loves daughter-ACC  
'The mother loves the daughter'

- (b) *Doc*                      *ljubit mat'*  
 daughter-NOM loves mother-ACC  
 'The daughter loves the mother'
- (c) \**Doc*                      *ljubit mat'*  
 Daughter-ACC-TOP loves mother-NOM

Bloom assumes that in sentences 7.2a-b, which have clearly marked case, there is a rule for constructive case attached to each nominal. He assumes that in 7.3, however, only the SVO order is permitted.<sup>2</sup>

In Bloom's analysis for 7.2a, *Mama* would have (SUBJ ↑) and *papu* would have (OBJ ↑). That is, the former states "I am a subject" and the latter "I am an object." Moreover, Bloom also attaches a (↑GF) = SUBJ rule to unambiguously nominative nominals and a (↑GF) = OBJ rule to unambiguously accusative ones. He claims that this is necessary to account for case stacking and agreement, as in Nordlinger (1998).

So Bloom's lexical rule for an unambiguously accusative noun *papu* 'father' is as below:

- (7.4) *papu* N (↑PRED) = 'FATHER'  
 (↑GEND) = MASC  
 (↑NUM) = SG  
 (↑PERS) = 3  
 (↑CASE) = ACC  
 (↑GF) = OBJ  
 (OBJ ↑)

The c-structure rule for each NP states either that the GF or grammatical function is constructed internally, or it is specified structurally in the c-structure rules. The trees that Bloom gives differs from the one below in that the disjunction is not specified and he leaves out some of the lexical rules attached to each nominal. But, given the information he presents elsewhere, I believe that these trees capture

---

<sup>2</sup>King (1995, 2, fn. 2) contradicts this notion by claiming that the supposedly disallowed reading in 7.3c is in fact allowed given the proper context.

the intuition behind his approach.

To understand how Bloom represents word order freezing in LFG, it will be useful to pursue the Russian examples further along with their corresponding c-structures and f-structure in 7.5-7.8. The first two c-structures, 7.5a and 7.6a, show the *differentiated* nominals for nominative and accusative. The rule  $\{(\uparrow\text{SUBJ})=\downarrow|(\uparrow(\downarrow\text{GF}))=\downarrow\}$  on the first nominal in the first two examples states “either I am my mother’s subject or “my daughter has transferred a GF upward and I am that GF for my mother.” So, in 7.5a, *Mama* is unambiguously nominative and can thus declare itself a subject. Either disjunction in  $\{(\uparrow\text{SUBJ})=\uparrow|(\uparrow(\downarrow\text{GF}))=\downarrow\}$  can be taken with no difference in result. Likewise, *papu* is unambiguously accusative and declares itself an object. Again, either disjunction in  $\{(\uparrow\text{OBJ})=\uparrow|(\uparrow(\downarrow\text{GF}))=\downarrow\}$  is permissible and a viable option without causing a contradiction.

In 7.2b, the order of subject and object is reversed. But *mama* still declares itself a subject ( $\text{SUBJ}\uparrow$ ) and *papu* declares itself an object ( $\text{OBJ}\uparrow$ ). Thus, when faced with the disjunction  $\{(\uparrow\text{SUBJ})=\downarrow|(\uparrow(\downarrow\text{GF}))=\downarrow\}$  for the NP headed by *papu*, it simply cannot be  $(\uparrow\text{SUBJ})=\downarrow$  because that would directly contradict ( $\text{OBJ}\uparrow$ ). Therefore, the option taken must be  $(\uparrow(\downarrow\text{GF}))=\downarrow$ . In this case,  $(\downarrow\text{GF}) = \text{OBJ}$ , so  $(\uparrow\text{OBJ}) = \downarrow$  for the *papu* NP. A similar logic means that *mama* is still necessarily the subject even though it comes after the verb. All of this can be seen in 7.6.

Now, let us consider the word freezing instances in 7.3. *Mat'* and *doč* are both ambiguous between nominative and accusative. Thus, they cannot project either  $(\uparrow\text{SUBJ})$  or  $(\uparrow\text{OBJ})$  via constructive case since it could just as easily project one as the other, and that would cause a contradiction. In other words, neither *Mat'* nor *doč* in the current system is able to mark itself as having any particular GF. Because no GF is passed up to the NP, the first respective options of the disjunctions  $\{(\uparrow\text{SUBJ})=\downarrow|(\uparrow(\downarrow\text{GF}))=\downarrow\}$  and  $\{(\uparrow\text{OBJ})=\downarrow|(\uparrow(\downarrow\text{GF}))=\downarrow\}$  disjunctions *must* be chosen since the second part is simply no longer an option. As a result, with these





(7.7) (Bloom, 1999, 67)

(a)

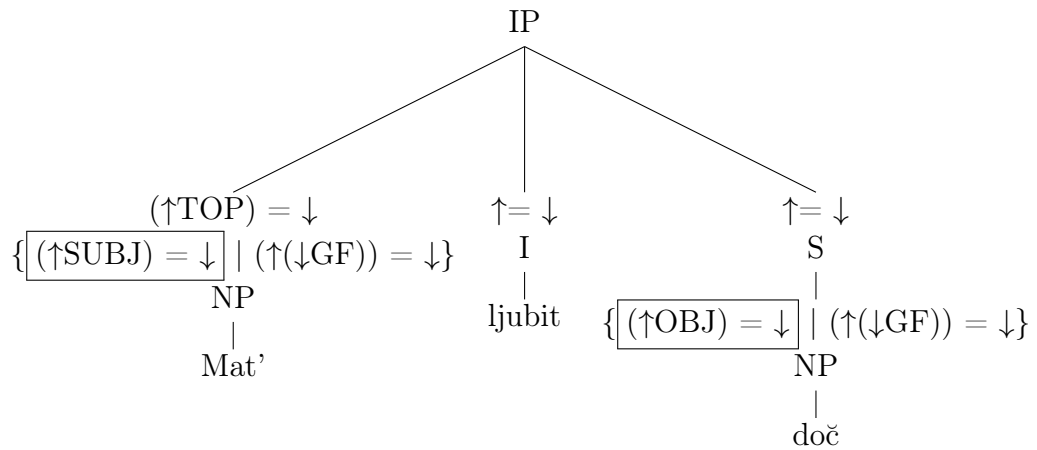

(b)

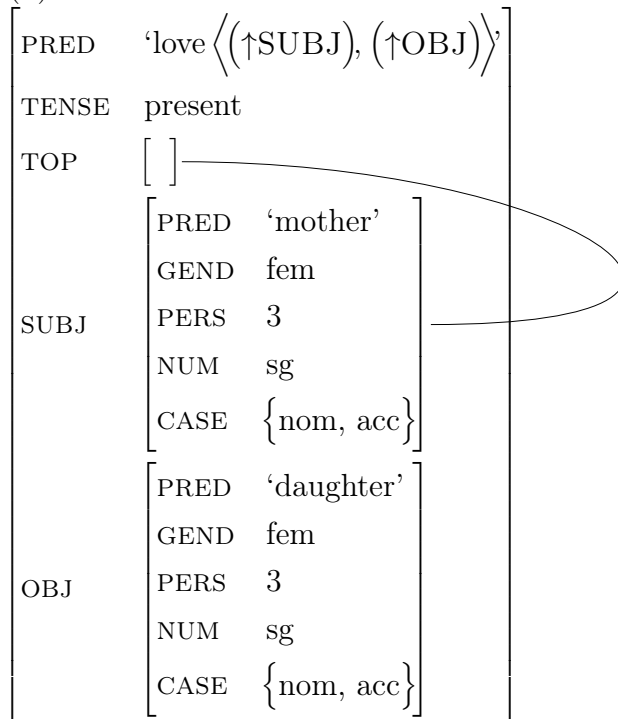

(7.8) (Bloom, 1999, 68)

(a)\*\*\*c-structure forced into unavailable option marked with \*

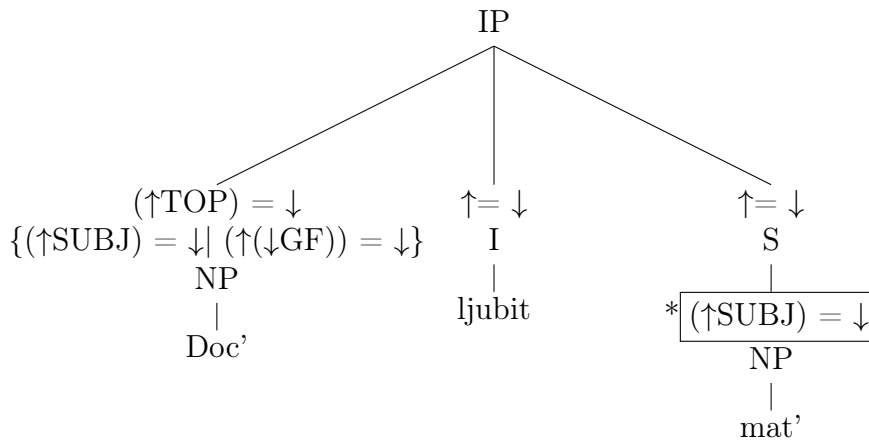

(b)\*\*\*

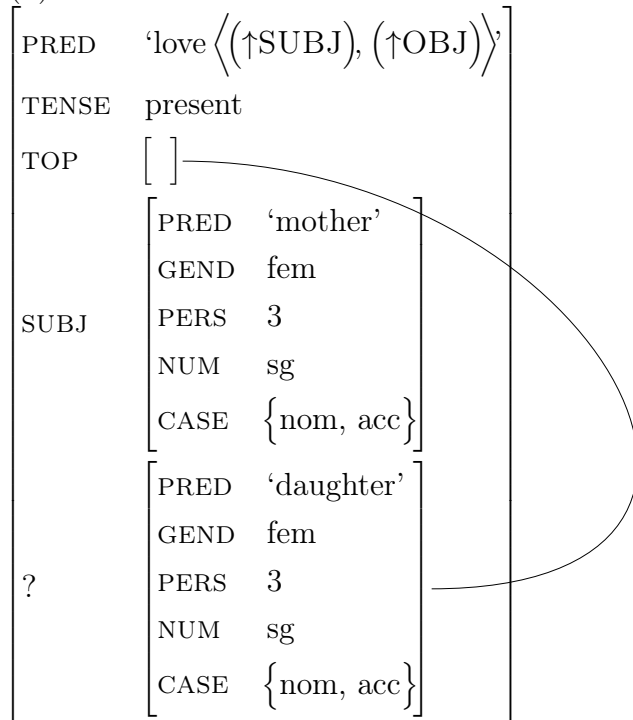

(7.9)

- (a) *Mal'čik videl lošad'*  
boy-NOM saw horse-NOM-ACC  
'the boy saw the horse'
- (b) ?*Lošad' mal'čik videl.*  
horse-NOM-ACC-TOP boy-NOM saw  
? 'The boy saw the horse'
- (c) ?*Lošad' videl mal'čik.*  
horse-NOM-ACC-TOP saw boy-NOM  
? 'The boy saw the horse'

ambiguous instances in 7.3a and 7.3b, the order is frozen as SVO. In 7.7, this works out fine. But the c-structure paired with the f-structure in 7.8, in which the second nominal is the subject, is simply not possible since that would require taking the first option of the disjunction  $\{(\uparrow\text{SUBJ})=\downarrow|(\uparrow(\downarrow\text{GF}))=\downarrow\}$ —which we have already said can't be done. In the c-structures that illustrate this, note that I have boxed the part(s) of the disjunction selected for each construction represented.

Bloom's analysis apparently works satisfactorily for Russian in which an ambiguously marked nom-acc object cannot appear pre-verbally in the topic position even when the other nominal element *is* unambiguously marked. Consider 7.9a-c. In these examples, the object is ambiguous in case and, regardless of the subject's case status, it still cannot be topicalized unproblematically. The same cannot be said, however, for other languages. This lacuna will be returned to in 7.3.

## 7.2.2 Information-structural account of Russian freezing

In personal discussion, Louise Mycock has suggested that Bloom's analysis fails to give appropriate consideration to information structural factors. That is, she joins King (1995) in rejecting the idea that grammatical functions like SUBJ and OBJ

(7.10) SVO

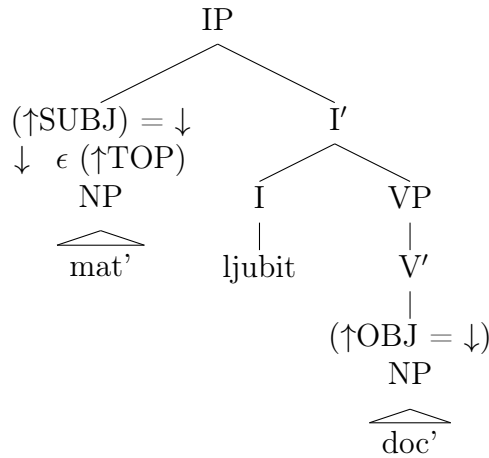

(7.11) OVS (assumes that the NP1 is marked by context as OBJ)

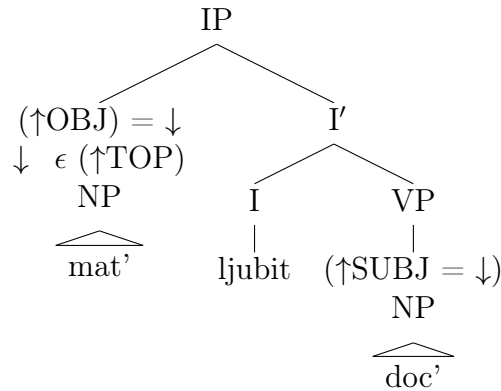

even have structurally assigned positions in Russian c-structure rules. Rather, it is information-structural constraints on discourse functions that determine word order.

For King (1995), the default order for Russian is actually V-first. The fact that a nominal frequently appears pre-verbally is an artifact of there being a TOPIC position in Spec,IP that is marked  $\downarrow\epsilon$  ( $\uparrow$ TOP) and  $(\uparrow$ GF) =  $\downarrow$ . These rules suggest that the doubly ambiguous Russian sentences could receive trees as in 7.10 and 7.11, which are based on similarly structured trees for different sentences in King (1995, 206, 224).

Contrary to what Bloom claims, the grammatical function in these trees

is not determined by c-structure. Rather, particular c-structure positions are associated with particular discourse functions. This still allows a morphologically ambiguous sentence to be disambiguated. In a completely unmarked context in which it is not immediately clear which element is being used as a topic, Lambrecht (1994, 132) provides a way to do that. He posits both that topic followed by comment<sup>3</sup> is a default pragmatic ordering and that subjects are topics in an unmarked context. In Russian, we already know from King (1995) that the topic appears in Spec,IP. We add to that knowledge the fact that, cross-linguistically, topics are usually subjects. We then arrive at a way to disambiguate an ambiguous clause. That is, if it is not clear from context which of two nominals is acting as SUBJ, it can be assumed that it is the one that is also TOPIC. This analysis helps clear up an example like 7.10: it is natural that the first of the two ambiguous nominals will be taken to be both TOPIC and SUBJ, whereas the second NP will be taken to be the OBJ and part of the comment.

How then can we explain 7.11? This is a structure that Bloom's analysis explicitly disallows. But, as King (1995, 2, fn. 2) points out, discourse effects can easily override the freezing effects. If indeed the first nominal is clearly an object, then we can conclude that it is both an OBJ *and* a TOPIC since it is in TOPIC position. Even though this is less common and less canonical than a configuration in which the topic is a subject, this construction is perfectly legitimate provided that the context calls for it. There is no need to turn to c-structural GF assignment as in Bloom. But Lambrecht's idea that SUBJ and TOPIC are interwoven in this way makes it easy to see how Bloom comes to associate Spec,IP with ( $\uparrow$ GF) = ( $\uparrow$ SUBJ).<sup>4</sup>

---

<sup>3</sup>*Comment* basically refers to that which is being said about the topic.

<sup>4</sup>See also Alsagoff (1992) for an LFG account of how SUBJ and TOPIC are linked in Malay.

### 7.3 Dutch and Old English word order freezing

Unlike with Russian, in Old English only when *both* nominal arguments of a transitive verb are ambiguous for case *and* there is no other disambiguating information does the word order freeze. The same is true of the closely related Dutch. Let's examine the following Dutch sentences from Bouma (2011).<sup>5</sup>

- (7.12) (a) *De Rode Duivels verslaan Oranje.*  
The Red Devils.PL beat.PL Orange.SG  
'The Red Devils beat the Dutch national football team.'
- (b) *De Rode Duivels verslaat Oranje.*  
The Red Devils.PL beats.SG Orange.SG  
'The Dutch national football team beat the Red Devils.'
- (c) *België verslaat Oranje.*  
Belgium.SG beat.SG Orange.SG  
Belgium beat the Dutch national football team.<sup>6</sup>  
NOT: The Dutch national football team beat Belgium.

Note that, while *De Rode Duivels* and *Oranje* are both themselves ambiguous for case, the distinction between (a) and (b) suggests that the mere presence of disambiguating verb agreement is enough to allow unambiguous meanings. In the case of (c), however, in which the verb is of no help in deciding what is the subject and what is the object, we see word order freezing. The SVO order is frozen.

Bouma (2011) handles this through a rather complicated bidirectional OT analysis. But it should be readily apparent that Bloom's LFG analysis cannot be applied to Dutch in the same way that we saw for Russian. Likewise, applying Bloom's c-structure and lexical rules to Old English would cause freezing to occur where it need not: for instance, in a sentence with two nom-acc ambiguous nominals

---

<sup>5</sup>Bouma points out that he is assuming a "hat" (rising on the first nominal and falling on the second) intonation pattern for all three of these sentences. Without that intonation, the freezing effect will not necessarily be achieved.

<sup>6</sup>The Dutch national football team, apparently, is known as The Orange.

but in which verb agreement means that only one can be the subject. Fundamentally, we do not wish to enforce word order freezing only when we have ambiguous case. We want it enforced only when there is no other possible way to disambiguate the clause. For instance, consider a sentence in which the object is topicalized and appears before the subject but in which neither is differentiated for case, as in 7.13.

Although both *stanas* and *cyning* are independently ambiguous, 7.13b shows the only acceptable f-structure since the f-structure in 7.13c is inconsistent. The verb *bræc* constrains the subject to be singular. But *stanas* is necessarily plural. As long as there is only one possible subject that is in agreement with the verb, the topicalized object will be understood as the object without any problem. It is only in sentences in which *both* subject and object are ambiguous for case and in which there are no other morphological cues for differentiating the nominals that the freezing effect occurs, as in 7.14a. Although both f-structures in 7.14b-c are complete and coherent, we must figure out a way to disallow 7.14c because, when ambiguity arises, the subject must come first.

## 7.4 Word order freezing in LFG

How can we represent this data in LFG? I will ultimately come down on the side of using a special variant of OT within the LFG framework. But, first, I will explore how freezing could be handled in LFG without the use of OT constraints. In doing so, I will draw on Dalrymple et al. (2009), who reject a set-based account of case ambiguity and instead turn to indeterminacy by feature underspecification. That is, instead of representing an ambiguous nom/acc nominal like *stan* by set membership  $(\uparrow\text{CASE}) = \{\text{NOM}, \text{ACC}\}$ , they represent case by features. *Stan* would have the features  $(\uparrow\text{CASE GEN}) = -$  and  $(\uparrow\text{CASE DAT}) = -$ . The feature values for  $(\uparrow\text{CASE NOM})$  and  $(\uparrow\text{CASE ACC})$  would remain unspecified if and until

(7.13)

(a) *stanas*                      *bræc*              *cyning*  
stones-NOM/ACC   broke.SG   king-NOM/ACC  
‘the king broke stones’

(b) 
$$\left[ \begin{array}{l} \text{SUBJ} \left[ \begin{array}{l} \text{PRED} \text{ 'king'} \\ \text{CASE} \text{ nominative} \\ \text{PERS} \text{ 3} \\ \text{NUM} \text{ sg} \end{array} \right] \\ \text{PRED} \text{ 'break } \langle \langle (\uparrow\text{SUBJ}) (\uparrow\text{OBJ}) \rangle \rangle \text{'}$$

(c) \*\*\* 
$$\left[ \begin{array}{l} \text{SUBJ} \left[ \begin{array}{l} \text{PRED} \text{ 'stone'} \\ \text{CASE} \text{ nominative} \\ \text{PERS} \text{ 3} \\ \text{NUM} \left[ \begin{array}{l} \text{sg} \\ \text{pl} \end{array} \right] \end{array} \right] \\ \text{PRED} \text{ 'break } \langle \langle (\uparrow\text{SUBJ}) (\uparrow\text{OBJ}) \rangle \rangle \text{'}$$

(7.14)

- (a) *cyningas*                      *bræcon.PL* *stanas*  
stones-NOM/ACC broke            kings-NOM/ACC  
‘Kings broke stones.’  
\*‘Stones broke kings.’

(b)

SUBJ	<table style="border-collapse: collapse; border: none;"> <tr><td style="border-right: 1px solid black; padding-right: 5px;">PRED</td><td style="padding-left: 5px;">‘king’</td></tr> <tr><td style="border-right: 1px solid black; padding-right: 5px;">CASE</td><td style="padding-left: 5px;">nominative</td></tr> <tr><td style="border-right: 1px solid black; padding-right: 5px;">PERS</td><td style="padding-left: 5px;">3</td></tr> <tr><td style="border-right: 1px solid black; padding-right: 5px;">NUM</td><td style="padding-left: 5px;">pl</td></tr> </table>	PRED	‘king’	CASE	nominative	PERS	3	NUM	pl
PRED	‘king’								
CASE	nominative								
PERS	3								
NUM	pl								
PRED	‘break $\langle\langle(\uparrow\text{SUBJ})(\uparrow\text{OBJ})\rangle\rangle$ ’								
TENSE	past								
OBJ	<table style="border-collapse: collapse; border: none;"> <tr><td style="border-right: 1px solid black; padding-right: 5px;">PRED</td><td style="padding-left: 5px;">‘stone’</td></tr> <tr><td style="border-right: 1px solid black; padding-right: 5px;">CASE</td><td style="padding-left: 5px;">acc</td></tr> <tr><td style="border-right: 1px solid black; padding-right: 5px;">PERS</td><td style="padding-left: 5px;">3</td></tr> <tr><td style="border-right: 1px solid black; padding-right: 5px;">NUM</td><td style="padding-left: 5px;">pl</td></tr> </table>	PRED	‘stone’	CASE	acc	PERS	3	NUM	pl
PRED	‘stone’								
CASE	acc								
PERS	3								
NUM	pl								

(c) \*\*\*

SUBJ	<table style="border-collapse: collapse; border: none;"> <tr><td style="border-right: 1px solid black; padding-right: 5px;">PRED</td><td style="padding-left: 5px;">‘stone’</td></tr> <tr><td style="border-right: 1px solid black; padding-right: 5px;">CASE</td><td style="padding-left: 5px;">nominative</td></tr> <tr><td style="border-right: 1px solid black; padding-right: 5px;">PERS</td><td style="padding-left: 5px;">3</td></tr> <tr><td style="border-right: 1px solid black; padding-right: 5px;">NUM</td><td style="padding-left: 5px;">pl</td></tr> </table>	PRED	‘stone’	CASE	nominative	PERS	3	NUM	pl
PRED	‘stone’								
CASE	nominative								
PERS	3								
NUM	pl								
PRED	‘break $\langle\langle(\uparrow\text{SUBJ})(\uparrow\text{OBJ})\rangle\rangle$ ’								
TENSE	present								
OBJ	<table style="border-collapse: collapse; border: none;"> <tr><td style="border-right: 1px solid black; padding-right: 5px;">PRED</td><td style="padding-left: 5px;">‘king’</td></tr> <tr><td style="border-right: 1px solid black; padding-right: 5px;">CASE</td><td style="padding-left: 5px;">acc</td></tr> <tr><td style="border-right: 1px solid black; padding-right: 5px;">PERS</td><td style="padding-left: 5px;">3</td></tr> <tr><td style="border-right: 1px solid black; padding-right: 5px;">NUM</td><td style="padding-left: 5px;">pl</td></tr> </table>	PRED	‘king’	CASE	acc	PERS	3	NUM	pl
PRED	‘king’								
CASE	acc								
PERS	3								
NUM	pl								

something came along to specify it. For instance, the nominative determiner *se* used in conjunction with *stan* would assign *stan* ( $\uparrow$ CASE NOM) = + and ( $\uparrow$ CASE ACC) = –.

If no such disambiguating features are present, then *stan* would remain underspecified for case. With this proposal, Dalrymple et al. (2009) solve the so-called transitivity problem exemplified in German in 7.15. *Hilft* takes a dative object and *Papageien* is ambiguously acc/dat. The noun *Papageien* could meet the verb’s dative requirement if its case was ( $\uparrow$ CASE) = {ACC, DAT} and meet the determiner *die*’s accusative requirement with the same constraint ( $\uparrow$ CASE) = {ACC, DAT}. This is problematic.

(7.15) *Er hilft \*die/den Papageien*  
 he helps \*the-ACC/the-DAT parrots-ACC/DAT  
 ‘he helps the parrots’

The feature underspecification approach would simply state initially that *Papageien* is –GEN and –NOM, which would allow it to be either accusative or dative. The presence of a dative verb would then add the feature –ACC. Thus, the determiner in this example could not be *die*-ACC since that would make the nominal impossibly –ACC as well as +ACC. This approach also solves the second-order indeterminacy problem, whose details can be found in the 2009 paper.

Through this feature underspecification approach, it is possible to construct a series of rules that model Old English word order freezing. For purposes of simplicity, I will address only nom/acc ambiguity in the example below. But the rules could in theory be extended for any other type of case ambiguity. For each verb that takes a nominative subject and an accusative object, the rules will be:

(7.16) ( $\uparrow$ PRED) = ‘break <( $\uparrow$ SUBJ)( $\uparrow$ OBJ)>’  
 ( $\uparrow$ SUBJ CASE nom) = +  
 ( $\uparrow$ OBJ CASE acc) = +

This much is straightforward and merely states that the verb requires a subject that is +NOM and an object that is +ACC. The next bit is more complicated and handles the word order freezing restriction. Each nominal can be either a) differentiated for case or b) ambiguous between nominative and accusative. For simplicity, we will assume that both are morphologically negative for dative and genitive. The freezing effect takes place only if both nominals match the number requirement imposed by the verb.

$$(7.17) \left\{ \begin{array}{l} (\uparrow\text{SUBJ CASE acc}) =_c - \left| \begin{array}{l} \sim(\uparrow\text{SUBJ CASE acc}) = - \\ (\uparrow\text{OBJ CASE nom}) =_c - \left| \begin{array}{l} \sim(\uparrow\text{OBJ CASE nom}) = - \\ \text{SUBJ} <_f \text{OBJ} \end{array} \right. \end{array} \right. \end{array} \right\}$$

- if  $\sim(\uparrow\text{SUBJ CASE acc}) = -$ 
  - then if  $\sim(\uparrow\text{OBJ CASE nom}) = -$ 
    - then  $\text{SUBJ} <_f \text{OBJ}$

These rules are simpler than they at first appear. Imagine that the first nominal in a given sentence is GF1 and the second one GF2, where GF can be either SUBJ or OBJ. The first part of the first disjunction is  $(\uparrow\text{SUBJ CASE ACC}) = -$ . If this is true (and we are assuming that both nominals are negative for dative and genitive) for GF1, then the only thing that GF1 can rightfully be without contradiction is the subject. That is, if the nominal represented by GF1 is negative for accusative case, the rest of the rules need not apply since there is no ambiguity possible even if GF2 is ambiguous. The second half of the main disjunction, which starts at Line 2 assumes that GF1 is not in fact -ACC. The negated construction  $\sim(\uparrow\text{SUBJ CASE ACC}) = -$  is used rather than  $(\uparrow\text{SUBJ CASE ACC}) = +$  because it is not necessary that a positive value be instantiated in order for ambiguity to occur. It only has to be not instantiated as negative. The only thing that can instantiate  $\text{ACC} = +$  is the verb, and the presence of other disambiguating factors,

like an accusative determiner, would serve merely to eliminate all the case options except ACC. In sum, Line 2 means that GF1 is ambiguous between nominative and accusative. Line 3 says that, given ambiguous GF1, if GF2 is –NOM, the ambiguity is removed. Line 4 shows what happens, however, if GF2 is also not –NOM. This is the two-way ambiguous condition and, as per Line 5, the SUBJ is stipulated through f-precedence as preceding the OBJ.<sup>7</sup>

Let’s see how this would work for the two example sentences from before.

- (7.18) *stanas*                      *bræc* *se*                      *cyning*  
 stones-NOM/ACC   broke   the-NOM   king-NOM  
 ‘The king broke stones.’

In this instance, *stanas* is –GEN and –DAT since the genitive plural of *stan* would be *stana* and the dative plural *stanum*. It is unspecified morphologically for NOM and ACC. *Cyning* is in and of itself also –GEN and –DAT. But the presence of the nominative determiner *se* means that it is also –ACC. The verb *bræc* searches for two arguments: a nominative subject and an accusative object. For illustration, let’s assume that *stanas* is the SUBJ and *cyning* is the object. *Stanas* is not –ACC, so Line 1 is false and Line 2 is true. *Cyning* is not –NOM, so Line 3 is false and Line 4 is true which means that the SUBJ must linearly precede the OBJ. This is not the case. Therefore, *stanas* cannot be the subject and *cyning* cannot be the object.

If we assume the arguments are reversed and that *stanas* is the object and *cyning* the subject, then Line 1 is true because *cyning* is in fact –ACC due to the presence of the nominative determiner *se*. No other conditions need apply. The

---

<sup>7</sup>The notation used here indicates f-precedence. F-precedence is defined by Kaplan and Zaenen (2003) as follows: “For any f-structures *f* and *g*, *ff*-precedes *g* (written  $f <_f g$ ) if and only if all the c-structure nodes that map to *f* precede all the c-structure nodes that map to *g*.” F-precedence has important theoretical implications for LFG since left-to-right ordering rules typically apply only in the c-structure but not in the f-structure. The use of f-precedence allows ordering constraints to flow between the c-structure and the f-structure. See also Zaenen and Kaplan (1995).

verb will seek out a nominative subject and assign +NOM to *cyning*, and it will assign +ACC to *stanas*.

Now, I will show what happens in an example with legitimate word order freezing.

- (7.19) *And on þison gere ec swac Harðacnut Eadulf eorl under*  
And in this year also deceived Harthacnut Eadulf eorl under  
*his griðe*  
his truce  
And in that year Harthacnut also deceived Eadulf eorl in his truce  
(cochronC,ChronC\_[Rositzke]:1041.6.1802)

Both *Harðacnut* and *Eadulf* are –GEN and –DAT with morphologically unspecified NOM and ACC values. If we assume that *Harðacnut* is the SUBJ and *Eadulf* is the OBJ, then Line 1 is false and Line 2 is true since *Harðacnut* is not –ACC. Line 3 is false and Line 4 is true since *Eadulf* is not –NOM. Therefore, Line 5 must be true and the SUBJ must come before the OBJ. This works correctly. If we had chosen the other way and assigned *Eadulf* SUBJ and *Harðacnut* OBJ, it would have been impossible to work out.

While this approach works for nominative and accusative ambiguity, I have so far ignored other types of ambiguity that can arise. For instance, there can also be accusative/dative ambiguity. Thus, every verb that takes three arguments—a nominative subject, an accusative object, and a dative object—would have an extremely complicated set of rules attached to it. Especially problematic is that even relatively straightforward sentences with little ambiguity would have to be pushed through the complicated set of disjunctions described above. The same analysis that I have proposed here for Old English could be applied to Dutch as well.

It is worth noting here that this analysis is entirely consistent with the information-structural account of word order freezing presented for Russian as

an alternative to Bloom (1999). If we assume that OE follows Russian in having discourse-determined structure, we can easily modify the rules to reflect that Spec,IP (which is typically where the first nominal is found) is not necessarily associated with ( $\uparrow$ SUBJ) at all but is simply a TOPIC position. This fits neatly in with the results of Chapter 6, in which I make exactly such a claim as a means of explaining why pronominal subjects (which are typically topics) must appear in Spec,IP and not Spec,VP. If we then accept the Lambrecht argument that SUBJ and TOPIC are linked by default, the “frozen” SVO order is no longer a mystery but is merely a by-product of the information-structural effect.

## 7.5 Word order freezing in LFG with OT

OT and LFG in conjunction provides a perhaps simpler solution. The OT that I implement here is not exactly Optimality Theory in the classical sense as first proposed by Prince and Smolensky (2004). Rather, it is based on the XLE implementation of OT constraints. Crouch et al. (1998) describe the OT options in XLE as an instantiation of the “most common mechanism used in Optimality Theory.” For word order freezing, I propose that we institute a weak constraint for SUBJ  $<_f$  OBJ that could be introduced and applied *only* in instances in which no unambiguous parse is derived for a given sentence. Although this arguably violates LFG’s commitment to monotonicity, it is a far simpler way to explain word order freezing.

We can implement this constraint through a simple OT tableau.<sup>8</sup> For each sentence, we can imagine a tableau like the one shown in 7.20.

---

<sup>8</sup>Besides Prince and Smolensky (2004), also see Kager (1999) for a general introduction and Kuhn (2003) for a specifically syntactic approach to OT.

(7.20)

	CC	SO
A		
B		

A and B represent arbitrary parses of the same sentences. The first column CC represents the dominant constraint and stands for completeness and coherence in the LFG sense. The second column represents the looser constraint that  $\text{SUBJ} <_f \text{OBJ}$ . In OT terms  $\text{CC} \gg \text{SO}$ . Thus, if completeness or coherence is violated at all in a given analysis, that analysis is immediately eliminated from contention. If completeness and coherence are satisfied for both parses, but one parse has  $\text{SUBJ} <_f \text{OBJ}$  and the other has  $\text{OBJ} <_f \text{SUBJ}$ , the optimal analysis is the one in which  $\text{SUBJ} <_f \text{OBJ}$ .

Let's return to the examples and f-structures in 7.13 and 7.14. In 7.13a, *cyning* and *stanas* are ambiguous out of context, and it is possible to imagine two f-structures, one in which *cyning* is the subject and one in which it is the object. But 7.13c shows an f-structure that violates consistency. 7.13b was the only permissible f-structure. We would assign it a tableau as in 7.21.

(7.21)

	CC	SO
☞ 7.13 b		*
7.13 c	*!	

Note that the reading in 7.13b receives a dispreference mark for SO since it offers a reading in which the object precedes the subject, whereas 7.13c has the preferred SO order. But, because 7.13c has a crucial violation of consistency, it is automatically disallowed. The pointing hand indicates that we take 7.13b.

What happens in examples like 7.14 or 7.19 in which we see word order freezing actually occur? For 7.14, we would get the following tableau:

(7.22)

	CC	SO
☞ 7.14 b		
7.14 c		*!

Neither f-structure 7.14b or 7.14c is incomplete or incoherent. But 7.14b violates the constraint that  $\text{SUBJ} <_f \text{OBJ}$ . Because there are no completeness or coherence violations,  $\text{SUBJ} <_f \text{OBJ}$  becomes the crucial constraint and receives the ! to indicate that. The little hand points to 7.14b to indicate that we take that one. A similar logic would explain 7.19. Note that this approach is distinct from the OT-LFG used by Clark (2004) in that, whereas his OT operates largely independently from his LFG constraints, the vast majority of my grammar is subsumed by the LFG CC constraint. The OT is just one additional layer of structure.

## 7.6 On psychological reality

Ultimately, the data can be explained effectively through either the OT constraints or through the pure LFG description. But questions remain as to whether word order freezing is a syntactic phenomenon at all. Bouma (2011) provides an overview of a debate between those who see it as syntactic and those who see it as a processing constraint. Those that view freezing as a processing constraint point to the fact that it can easily be overcome by prosodic and pragmatic factors. Indeed, it can be a relatively weak constraint. Bouma, however, notes that the effect manifests itself in language as soon as morphological case fails to disambiguate the reading. He proposes a bidirectional OT model of language by which both the speaker and the hearer conspire to avoid meaningful ambiguity. I do not have space to do full justice to the theory, but it more or less states that, given a free word order language, if the hearer does not have morphological information to disambiguate the clause, she

will assume that the speaker is using word order cues. The speaker will make the same observation, and both parties will arrive at an unambiguous interpretation of the clause.

Tily (2010) provides experimental evidence for this process in Japanese. In a series of timed reading experiments, he finds that word order has little effect on clauses in which case is unambiguously marked. When case markings are removed, however, the reader slowed down considerably when faced with a pre-subject object. This strongly suggests that comprehenders turn to word order when and *only when* case marking is ambiguous.

Of course, we have no access to Old English speakers for this type of study, but, given the cross-linguistic nature of freezing effects, it is reasonable to assume that a similar process would take place in Old English. That is, word order constraints of the SUBJ  $<_f$  OBJ variety would not even enter the comprehender's range of options unless case, morphology, and agreement failed to disambiguate the sentence.

The OT approach that I have presented models this process in a way that is quite intuitive. That is, we could say that, only when comprehenders fail to encounter a crucial violation of completeness or coherence (my CC constraint) for differentiating a sentence do they turn to the weaker SO constraint.

This notion that speakers and comprehenders can selectively pay attention to different cues based on the information available to them has implications for the multi-projection approach that I have presented throughout this thesis. Speakers and comprehenders' attention can be diverted from one projection to the other based on what seems relevant in a given context. If morphology fails to deliver the necessary information, the speaker and comprehender will turn to word order. If a sentence is comprehensible but violates the expected word order, a discourse effect will be assumed. The way that LFG allows each of these layers to be distinctly

represented may be one of the reasons for its success in explaining languages like Old English. In future work, I believe that it may be possible to use LFG in conjunction with psychological experimentation to develop a theory of language in the mind. For present purposes, however, it is merely worth noting that there may be important psycholinguistic consequences for the approach that I have presented in this thesis.

# Chapter 8

## Conclusion

This thesis has considered several diverse problems in the study of Old English constituent order: the placement of the verb, the effect of information structure on subject position, and the complications of word order freezing. What we have discovered over and over is that the multi-projection architecture of LFG offers satisfying solutions to thorny issues that are difficult to explain away through other theories. The placement of the verb, along with the absence of the reverse brace construction, is explained by separating the c-structure and f-structure. Two very different c-structures, one rooted in exocentric S and one rooted in endocentric IP, could give rise to the same f-structure. Separating information structure material from the f-structure by placing it in the i-structure allowed us to explain the different, but not necessarily categorical, treatments required for pronominal subjects and full noun subjects in Old English. And I have shown the merits of an OT-LFG approach to word order freezing that allows an f-precedence rule to act on a sentence that would otherwise receive an ambiguous parse.

Besides just saying something about Old English, I hope that my work can also contribute cross-linguistically to LFG as a whole. The hierarchical verb cluster that occurs within a  $V_0$  head is, I believe, novel in the LFG literature. But I

believe that it could be applied to Dutch and other Germanic languages that have maintained the 2-1 verb clusters used in Old English. My work on information structure bolsters the claims made by Dalrymple and Nikolaeva (2011 forthcoming) and Bloom (1999) regarding a specific *i*-structure for LFG. Indeed, without recourse to the information structure projection, the Old English data is difficult to explain. Finally, the novel system that I presented for handling word order freezing through case indeterminacy (Dalrymple et al., 2009) lends further support to case indeterminacy as a means of handling case in LFG and also offers a framework that can be used to explain word order freezing in Dutch and Russian—a goal for future work.

Beyond this thesis, I hope to show how these projections and their interactions that I have posited for Old English can be modeled over time in order to explain how and more importantly why English word order has developed historically in the way that it has. This thesis has provided us with a set of changes to explain: the loss of exocentric S as a viable option in English, the loss of word order freezing, and the loss of a second subject position. The next step is to begin to unravel *why* these changes happened from both a linguistic and psychological perspective.

On that front, there is significant work to be done. It is occasionally claimed that languages change to become easier to process. That is, if we were able to prove that exocentric S is for some reason more difficult to process than IP, perhaps that would explain why S has disappeared from English. That notion makes intuitive sense but is problematic. If languages are inherently biased towards efficiency, then why would more complicated forms develop in the first place? Why would any language have S alongside IP? Cognitive science work on how different structures are parsed feels neglected in the major diachronic syntax studies that I have addressed in this thesis. Only recently, e.g. Tily (2010), have researchers begun combining experiments with research on diachronic phenomena.

In future work, I hope to see experiments that test whether the 2-1 verb clusters like *break should* are harder to process in languages that still have them, like German. It seems possible that its increased dependency length (Gibson, 1998) will indeed make it harder to process. That is, the object is farther from its licensing verb *break* and thus requires more memory. Ultimately, I believe it will be possible to apply these findings computationally through algorithms that model the disappearance of these clusters throughout the history of English. If indeed the clusters are harder to process than the more familiar finite-first order, I expect that the clusters will also be shown to be decreasing in frequency in modern German, even if very slowly. If not, then the conclusion is either that processing does not affect language change or that some other factor, likely morphological, is at work in German that does not factor into English.

This is only one example of how the findings of this thesis could be fruitfully applied to the problem of language change. Ultimately, though, the fundamental questions of Old English constituent order underlie all of these concerns. What was permissible? Why is the reverse brace construction not present in the corpus? Why do full NP subjects seem to pattern differently from pronominal subjects? What happens to the constituent order when case is ambiguous? Was Old English an SVO language that sometimes had SOV or an SOV language that sometimes had SVO? Or was it some combination? I hope to have shown that the answers to these questions are interesting, nuanced, and worthy of careful consideration both now and in the future. While we may never be able to ask these questions of a native speaker of Old English, I believe that we are well on our way to answering them and, as a result, learning something about language at large.



# Bibliography

- Allen, Cynthia. 1995. *Case Marking and Reanalysis: Grammatical Relations from Old English to Early Modern English*. Oxford: Clarendon Press.
- Alsagoff, L. 1992. Topic in Malay: the other subject. Doctoral Dissertation.
- Andrews, Avery. 1985. The major functions of the noun phrase. In *Language Typology and Syntactic Description*, ed. T. Shopen. Cambridge: Cambridge University Press.
- Austin, Peter, and Joan Bresnan. 1996. Nonconfigurationality in Australian aboriginal languages. *Natural Language and Linguistic Theory* 14:215–68.
- Bean, Marian. 1983. *The development of Word Order Patterns in Old English*. Kent: Croom Helm, Ltd.
- Bech, Kristin. 2001. Word Order Patterns in Old and Middle English: A Syntactic and Pragmatic Study. Doctoral Dissertation, University of Bergen.
- Biberauer, T., and M. Richards. 2004. True optionality: when the grammar doesn't mind. Bloomington, IN: The Minimalist Theorizing Conference.
- Biberauer, T., and I. Roberts. 2003. The EPP and word order change in Middle English. The Eighteenth Comparative Germanic Syntax Workshop, University of Durham.

- Birner, B.J., and Gregory Ward. 2009. Information structure and syntactic structure. *Language and Linguistic Compass* 3:1167–1187.
- Bloom, Douglas. 1999. Case Syncretism and Word Order Freezing in the Russian Language. Master's thesis, Stanford.
- Bouma, Gerlof. 2008. Starting a sentence in Dutch: A Corpus Study of Subject- and Object- Fronting. Doctoral Dissertation, University of Groningen.
- Bouma, Gerlof. 2011. Production and comprehension in context: The case of word order freezing. In *Bidirectional Optimality Theory*.
- Bresnan, J., A. Cueni, T. Nikitina, and H. Baayen. 2007. Predicting the dative alternation. *Cognitive Foundations of Interpretation* 69–94.
- Bresnan, Joan. 2001. *Lexical-Functional Syntax*. Oxford: Blackwell Publishers.
- Butt, Miriam, and Tracy Holloway King, ed. 1997. *Focus domains and discourse function structure*. University of California, San Diego: The Proceedings of the LFG '97 Conference.
- Butt, Miriam, and Tracy Holloway King. 2000. Null elements in discourse structure. In *Papers from the NULLS Seminar*, ed. K.V. Subbarao. Delhi: Motilal Banarasidas.
- Butt, Miriam, Tracy Holloway King, María-Eugenia Nino, and Frédérique Segond. 1999. *A Grammar Writer's Cookbook*. Stanford: CSLI Publications.
- Choi, Hye-Won. 1996. Optimizing Structure in Context: Scrambling and Information Structure. Doctoral Dissertation, Stanford.
- Clark, Brady. 2004. A Stochastic Optimality Theory Approach to Syntactic Change. Doctoral Dissertation, Stanford.

- Crouch, Dick, Mary Dalrymple, Ron Kaplan, Tracy King, John Maxwell, and Paula Newman. 1998. *XLE User Documentation*. Palo Alto Research Center.
- Dalrymple, Mary. 2001. *Lexical Functional Grammar*. San Diego, CA: Academic Press.
- Dalrymple, Mary, Tracy Holloway King, and Louise Sadler. 2009. Indeterminacy by underspecification. *J. Linguistics* 45:31–68.
- Dalrymple, Mary, and Irina Nikolaeva. 2011 forthcoming. *Objects and Information Structure*. Cambridge: Cambridge University Press.
- Evans, N., and S. Levinson. 2009. The Myth of Language Universals: Language diversity and its importance for cognitive science. *Behavioral and Brain Sciences* 32:429–448.
- Falk, Yehuda. 2001. *Lexical-Functional Grammar*. Stanford: CSLI.
- Falk, Yehuda. 2003. The English Auxiliary System Revisted. In *The Proceedings of the LFG '03 Conference*, ed. Miriam Butt and Tracy Holloway King. University at Albany, State University of New York.
- Falk, Yehuda N. 1984. The English auxiliary system: A lexical-functional analysis. *Language* 60:483–509.
- Frank, Anette. 2002. A (Discourse) Functional Analysis of Asymmetric Pronouns. In *The Proceedings of the LFG '02 Conference*, ed. Miriam Butt and Tracy Holloway King. University of Athens, Athens.
- Fries, CC. 1940. On the development of the structural use of word order in Modern English. *Language* 16:102–64.
- Gibson, E. 1998. Linguistic complexity: Locality of syntactic dependencies. *Cognition* 68:1–76.

- Givón, T. (ed.). 1979. *Syntax and Semantics: Discourse and Syntax 12*. New York: Academic Press.
- Haerberli, Eric. 2002. Observations on the loss of verb second in the history of English. In *Studies in comparative German syntax*, ed. J.-W. Zwart and W. Abraham, 245–272. Amsterdam: John Benjamins.
- Haerberli, Eric, and Susan Pintzuk. 2006. Revisiting Verb (Projection) Raising in Old English. *York Papers in Linguistics Series* 2:77–94.
- Halliday, M.A.K. 1967. Notes on transitivity and theme in English: Part 2. *Journal of linguistics* 3:199–244.
- Hinterholzl, Roland, and Svetlana Petrova. 2010. From V1 to V2 in West Germanic. *Lingua* 120:315–328.
- Hiyama, Susumu. 2004. Old English verbal-Auxiliary clusters: Some notes. *Neophilologus* 88:121–129.
- Hogg, Richard. 2006. Old English Dialectology. In *The Handbook of the History of English*, ed. Ans van Kemenade and Bettelou Los, 395–416. Oxford: Blackwell Publishing.
- Kager, René. 1999. *Optimality Theory*. Cambridge: Cambridge University Press.
- Kaplan, Ronald, and Annien Zaenen. 2003. West-Germanic verb clusters in LFG. In *Verb Constructions in German and Dutch*, ed. Pieter A. M. Seuren and Gerard Kempen. Amsterdam: John Benjamins B.V.
- Kayne, R.S. 1994. *The Antisymmetry of Syntax*. Cambridge: The MIT Press.
- van Kemenade, Ans. 1987. *Syntactic case and morphological case in the history of English*. Holland: Foris.

- van Kemenade, Ans. 1999. Sentential negation and clause structure in Old English. *In Negation in the History of English* 147–165.
- van Kemenade, Ans. 2009. Discourse relations and word order change. *In Information Structure and Language Change* 91–120.
- van Kemenade, Ans, and Bettelou Los. 2006. Discourse Adverbs and Clausal Syntax in Old and Middle English. In *The Handbook of the History of English*, ed. Ans van Kemenade and Bettelou Los, 224–248. Oxford: Blackwell Publishing.
- van Kemenade, Ans, Tanja Milicev, and R. Harald Baayen. 2008. The balance between syntax and discourse in Old English. In *English Historical Linguistics 2006: Selected Papers from the Fourteenth International Conference on English Historical Linguistics (ICEHL 14), Bergamo, August 2006 Volume 1: Syntax and Morphology*, ed. Maurizio Gotti, Marina Dossena, and Richard Dury, 3–22.
- King, Tracy Holloway. 1995. *Configuring topic and focus in Russian*. CSLI publications.
- Koopman, Willem. 1990. *Word Order in Old English with Special Reference to the Verb Phrase: Amsterdam Studies in Generative Grammar 1*. Amsterdam.
- Koopman, Willem. 1998. Inversion after single and multiple topics in Old English. In *Advances in English Historical Linguistics*, ed. Jacek Fisiak and Marcin Krygier, 135–150. Berlin: Mouton de Gruyter.
- Koopman, Willem. 2004. Transitional syntax: postverbal pronouns and particles in Old English. *English Language and Linguistics* 9.1:47–62.
- Kuhn, Jonas. 2003. *Optimality-Theoretic Syntax - A Declarative Approach*. Stanford: CSLI Publications.

- Lambrecht, K. 1996. *Information structure and sentence form: topic, focus, and the mental representations of discourse referents*. Cambridge: Cambridge University Press.
- Lambrecht, Knud. 1994. *Cambridge Studies in Linguistics 71: Information Structure and Sentence Form: Topic, focus, and the mental representations of discourse referents*. Cambridge: Cambridge University Press.
- Lee, Hanjung. 2001. Markedness and word order freezing. In *Formal and Empirical Issues in Optimality Theoretic Syntax, volume 5 of Studies in Constraint based Lexicalism.*, ed. Peter Sells. Stanford: CSLI Publications.
- Lightfoot, David. 1991. *How to Set Parameters: Arguments from Language Change*. Cambridge: MIT Press.
- Lightfoot, David. 1999. *The Development of Language: Acquisition, Change, and Evolution*. Cambridge: MIT Press.
- Mitchell, Bruce. 1985. *Old English Syntax*. Oxford: Oxford University Press.
- Morenhout, Mike, and Wim van der Wurff. 2005. Object-verb order in early sixteenth-century English prose: an exploratory study. *English Language and Linguistics* 9.1:83–114.
- Mycock, Louise. 2006. The Typology of Constituent Questions: a Lexical-Functional Grammar analysis of 'wh'-questions. Doctoral Dissertation, University of Manchester.
- Nordlinger, R. 1998. Complementizing Case in Australian languages: A constructive approach. In *LFG98 Conference, University of Queensland, Brisbane*.
- Nunes, Jario. 2002. VO or OV? That's the underlying question: commentary on

- Pintzuk. In *Syntactic effects of morphological change.*, ed. D.W. Lightfoot, 300–6. Oxford: Oxford University Press.
- Pintzuk, Susan. 1993. Verb seconding in Old English: Verb movement to Infl. *The Linguistic Review* 10:5–36.
- Pintzuk, Susan. 1999. *Phrase Structures in Competition: Variation and Change in Old English Word Order*. New York: Garland Publishing.
- Pintzuk, Susan. 2002. Morphological Case and Word Order in Old English. *Language Sciences* 24:381–395.
- Pintzuk, Susan. 2005. Arguments against a universal base: evidence from Old English. *English Language and Linguistics* 9.1:115–138.
- Pintzuk, Susan, and Eric Haeberli. 2008. Structural variation in Old English root clauses. *Language Variation and Change* 20:367–407.
- Pintzuk, Susan, and Ann Taylor. 2006. The Loss of OV Order in the History of English. In *The Handbook of the History of English*, ed. Ans van Kemenade and Bettelou Los, 249–278. Oxford: Blackwell Publishing.
- Potts, Kathryn Flack. 2007. Ambiguity avoidance as contrast preservation: Case and word order freezing in Japanese. In *UMass Occasional Papers in Linguistics 32: Papers in Optimality Theory III*.
- Prince, A., and P. Smolensky. 2004. Optimality Theory: Constraint interaction in generative grammar. In *Optimality Theory in phonology: A reader*, ed. John J. McCarthy. Oxford: Blackwell.
- Randall, B. 2000. *CorpusSearch: A Java Program for Searching Syntactically Annotated Corpora*. University of Philadelphia: Philadelphia; Department of Linguistics.

- Rissanen, Matti. 1998. Isn't it? or is it not? On the order of postverbal subject and negative particle in the history of English. In *On Negation in the History of English*, ed. Ingrid Tieken-Boon van Ostade and Gunnel Tottie and Wim van der Wurff, 189–205. Mouton de Gruyter.
- Roberts, Ian. 1997. Directionality and word order change in the history of English. In *Parameters of morphosyntactic change*, ed. A. van Kemenade and N. Vincent, 397–426. Cambridge: Cambridge University Press.
- Sadler, Louisa. 1997. Clitics and the Structure-Function Mapping. In *Proceedings of the LFG97 Conference, Stanford, CA*, ed. Miriam Butt and Tracy Halloway King. CSLI Publications.
- Sells, Peter. 1998. *Scandinavian clause structure and object shift*. On-line, Stanford University: <http://www-csli.stanford.edu/sells/scand.ps.gz>.
- Seoane, Elena. 2006. Information Structure and Word Order Change: The Passive as an Information-rearranging Strategy in the History of English. In *The Handbook of the History of English*, ed. Ans van Kemenade and Bettelou Los, 360–391. Oxford: Blackwell Publishing.
- Sonoda, Katsuhide. 1998. On the inseparable nature of verb-auxiliary combinations in Old English. In *English Historical Linguistics and Philology in Japan*, ed. Jacek Fisiak and Akio Oizumi, 313–321. Mouton de Gruyter.
- Taylor, Ann, Anthony Warner, Susan Pinzuk, and Frank Beths. 2003. *The York-Toronto-Helsinki Parsed Corpus of Old English Prose (YCOE)*. York: Department of Language and Linguistic Science, University of York. Available through the Oxford Text Archive.
- Taylor, Ann, and Wim van der Wurff. 2005. Special issue on Aspects of OV and VO

- order in the history of English: Preface by the guest editors. *English Language and Linguistics* 9:1–4.
- Tily, Harry. 2010. The role of processing complexity in word order variation and change. Doctoral Dissertation, Stanford.
- Toivonen, Ida. 2003. *Non-Projecting Words: A Case Study of Swedish Particles*. Dordrecht: Kluwer Academic Publishers.
- Warner, Anthony. 2006. Changes in Periphrastic Do. In *The Handbook of the History of English*, ed. Ans van Kemenade and Bettelou Los, 45–67. Oxford: Blackwell Publishing.
- Westergaard, M. R. 2005. Norwegian child language and the history of English: the interaction of syntax and information structure in the development of word order. In *Contexts - historical, social, linguistics. studies in celebration of toril swan*, ed. K. McAfferty, T. Bull, and K. Killie, 293–410. Bern: Peter Lang.
- Wurff, W. van der. 1999. Objects and verbs in modern Icelandic and fifteenth-century English: a word order parallel and its causes. *Lingua* 109:237–65.
- Wurmbrand, S. 2006. Verb clusters, verb raising, and restructuring. In *The Blackwell Companion to Syntax Vol. 5*, ed. M. Everaert and H. van Riemsdijk, 229–343. Oxford: Blackwell.
- Zaenen, Annie, and Ronald Kaplan. 1995. Formal Devices for Linguistic Generalizations: West Germanic Word Order in LFG. In *Formal Issues in Lexical Functional Grammar*, ed. Mary Dalrymple et al, 215–239. Stanford: CSLI.