

Concepts of Sovereignty among the Shambaa  
and their relation to Political Action

D.Phil. Thesis

by

Steven Feierman

Wadham College

October 1972<sup>MT</sup>

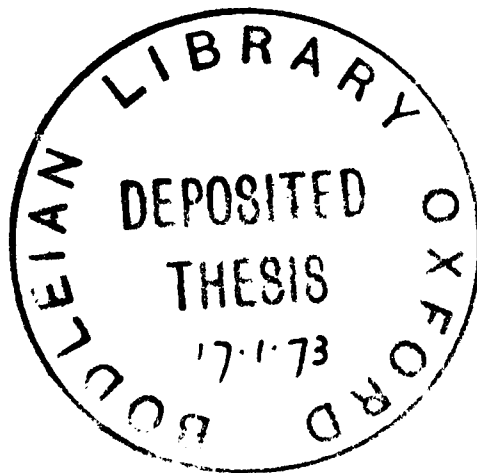

**Kwa Wantu  
wa Shambaai**

## PREFACE

The research for this thesis was done in Tanzania, between March 1966 and August 1968, and in German and English archives in 1965-1966. The research results have been analyzed in one previous work (Feierman 1970) on the history of the Shambaa kingdom.

The research and writing were done under the supervision of Dr. Rodney Needham, to whom I am deeply indebted for guidance and inspiration. I owe a great debt of gratitude to Dr. John Beattie, for reading and commenting on a number of chapters. While in Tanzania I received the invaluable assistance of Drs. John Iliffe, Terence Ranger, and Isaria Kimambo, of the University College, Dar es Salaam. I am deeply grateful to my colleagues at the University of Wisconsin: to Professor Jan Vansina, who read and commented on a number of the chapters, and to Professor Philip Curtin who encouraged me, and assisted me in finding time to write.

Literally hundreds of Shambaa helped me during my stay in Shambaai. I owe them all my thanks. Leo Hassani and Hatibu Hassani participated actively in the research, although any responsibility for errors is my own. I owe thanks for hospitality to my many hosts in Shambaai, and especially to the people of the villages of Bazo, Kwe Mbalazi, and Mayo.

I would like to thank the archivists of the Tanzania National Archives and of the United Society for the Propagation of the Gospel, the librarians of Rhodes House, the Welt-Wirtschafts-Archiv in Hamburg, the Bethel Mission in Bielefeld, and the University of Wisconsin. I am grateful to the officers of the regional administration in Tanzania, who assisted me in my research. I give my thanks to Dr. David Henige, who read and commented on portions of this work. I am very grateful to Mrs. Helen Hull, who worked long hours to type much of this thesis.

The research and writing for this thesis were supported by the Foreign Area Fellowship Program, the National Science Foundation, and the Comparative World History committee of the University of Wisconsin. However the conclusions, opinions, and other statements in this thesis are those of the writer and are not necessarily those of any grant committee.

Finally, I owe a very special debt to my wife Elizabeth, who participated enthusiastically in village life, and who has given me her special support through difficult years of writing and teaching.

## CONTENTS

	Page
PREFACE . . . . .	iii
INTRODUCTION . . . . .	1
CHAPTER ONE: THE SHAMBAA AND THEIR LAND . . . . .	25
PART I	
CHAPTER TWO: DESCENT GROUPS . . . . .	48
CHAPTER THREE: ALLIANCE, DOMESTIC GROUPS, AND TERRITORIAL INTEGRATION . . . . .	101
CHAPTER FOUR: ROYAL DESCENT AND ALLIANCE . . . . .	148
PART II	
CHAPTER FIVE: ROYAL DEATH AND ACCESSION . . . . .	209
CHAPTER SIX: VUGHA: THE ROYAL CAPITAL . . . . .	255
CHAPTER SEVEN: LITIGATION, WARFARE, AND TRIBUTE . . . . .	307
CHAPTER EIGHT: <u>KUZIFYA SHI</u> AND <u>KUBANA SHI</u> . . . . .	364
BIBLIOGRAPHY . . . . .	404

## FIGURES

		Page
1	Villages of Vugha which are more than 100 years old	37
2	Schematic representation of Hea clanship	55
3	Choice of residence by inherited women	66
4	Schematic representation of the lineage of Sk and Ki	80
5	Distribution of women to men of different age groups	115
6	Number of wives per man	120
7	Residence of married men in 1968, as related to birthplace	129
8	Residence of married men in 1968, as related to childhood home	130
9	Wife's childhood village as related to husband's current village	141
10	Existing ties among lineages of husbands and wives	143
11	Connexions between the descendants of Sk and SS	144
12	Responses to the question: 'who are the two or three men of your village senior enough to arbitrate disputes, and how are you related to them?'	146
12A	Kilindi lineage names, by generation	164
13	A summary of the discernible relationships between Kimweri ye Nyumbai and the governors of the chiefdoms at the time of Kimweri's accession	173
14	Schematic representation of the chiefs of Gare and Ubii at the time of Kimweri ye Nyumbai	179
15	Schematic representation of the Kilindi of Mlalo during the reign of Kimweri ye Nyumbai	182

	Page
16 Schematic representation of the chiefs of Mponde	184
17 Schematic representation of important Kilindi in the succession dispute after Kimweri ye Nyumbai's death	196

#### MAPS

	Following Page
Sketch map of the major chiefdoms of Shambaai	170
Sketch map of Vugha	258
Sketch map of the royal court	285
Survey map	at end

## INTRODUCTION

### I

This thesis is an attempt to explore the relationship between two bodies of evidence on the political organization of the Shambaa, of what is now northeastern Tanzania, as Shambaa politics was practised before colonial conquest (which took place in the early 1890's). On the one hand, the configurations of symbols and the sets of general concepts of the Shambaa view of politics clearly worked to suppress the sense of the passage of linear, non-reversible time. When a King died, his death was hidden until a new King was installed. The royal headdress was placed on the head of the new King at the same moment his predecessor's body was buried. Innumerable details of the construction of the royal capital were prescribed by tradition, and each new King had to maintain the capital and its constructions in the precise form adopted by his ancestor, the first King. All of Shambaa history was reduced, in Shambaa thought, to two possible states: there were strong Kings who dominated the chiefs and thereby brought fertility to the entire land; there were Kings whose reigns were characterized by 'force against force,' (nguvu kwa nguvu, that is, competition), in which cases there was famine.

On the other hand, it is clear that there was rapid change in patterns of political action throughout the history of the kingdom.

The author has described that change at length in another work (Feierman 1970). There were frequent changes not only in the distribution of power between King and chiefs, which could be interpreted as cyclical variations, but also in the potential sources of support for competing leaders (from tribute and alliances with commoners to trade and alliances with aliens), and in the borders of the kingdom. The changes were too frequent and too drastic to be ignored or forgotten by the Shambaa in their own understanding of their kingdom.

The contrast between the suppression of time (or rather the creation of a rhythmmed time) in the realm of general concepts, and the tyranny of time in the realm of political action provokes a series of questions about the relationship between concepts and action. How did the political symbols and general concepts persist in the face of changing experience? How did the Shambaa explain the changes which they experienced? It is clear that there was not a precise correspondence between ideas and action; what was the relationship between the two? The most important result of an attempt to view both concepts and action over time is that attention is focused on the border area between the two: on the way in which innovating leaders used old symbols for new purposes, and on the way in which categories changed their content over time.

This work returns to some of the problems raised by E. R. Leach in Political Systems of Highland Burma (1954) about the relationship between conceptual systems and social change. The problems are

worth returning to because Leach asked extremely important questions without, I feel, providing satisfying answers, and because, as Cohen has argued (1969), the relationship between political symbols and power relations is a central problem in political anthropology.

Leach stated, in his introduction to the Kachin study, that 'while conceptual models of society are necessarily models of equilibrium systems, real societies can never be in equilibrium' (1954: 4).<sup>\*</sup> How then could the Kachins preserve their inadequate models in the face of reality? The Kachins, Leach argued, had two contradictory models of society, each inherently unstable, one repudiating hereditary class differences, one emphasizing the importance of chiefs who were members of an hereditary aristocracy. The peculiar alternation between the egalitarian and aristocratic patterns was related to the geographic position of the Kachins on the border of the Shan states. Kachin chiefs, when they had the opportunity, modeled their behaviour on that of Shan princes (1954: 198, 213).

It seems to me that there are two important weaknesses of Leach's book. First, there is a lack of detailed historical knowledge which has important consequences for the argument. Leach shows that there are two Kachin conceptual models: the gumsa or aristocratic model,

---

<sup>\*</sup>This is, I think, a clumsy formulation. There is no reason conceptual models cannot include conditional statements or statements about potential developments: "If A happens, then B will follow." For an extended example of the use of the conditional in Shambaa thought see chapter viii.

and the gumlao or egalitarian model. He describes the two models in some detail, sketches the contradictions of each, and the way in which each social form is unstable, so that Kachin communities fluctuate between the two. He then gives a historical sketch to show, convincingly I think, that gumsa and gumlao categories existed at least a hundred years ago. The difficulty is that there is no way of knowing whether the verbal category gumsa (or gumlao) was used in referring to precisely the same patterns of action in the nineteenth century as in the twentieth. It would be of the greatest interest to know the differences between the gumsa society of a hundred years ago, and that of Leach's time, which it undoubtedly resembles; this would tell us whether 'change' in Kachin society is merely an unchanging fluctuation between alternative forms, or whether categories are reinterpreted with the passage of time. One of the central points of this thesis, which is made in chapter viii, is that indigenous categories for the explanation of political action are superficially the same over long periods, while their content changes.

The second limitation was initially noted by Raymond Firth, in his preface to Political Systems of Highland Burma. He wrote that Leach's theory was still largely special, and not a general one. Because Leach examined the extreme case of the Kachins, who lived at an ethnic boundary and were constantly 'becoming something else,' he was unable to demonstrate that his dynamic theory had general relevance --

that the analogy was not restricted merely to a special group of unstable societies which lack ethnic unity (1954: vii). The Shambaa, who live in an island of mountains, have always, in historical times, had a strong sense of their own cultural unity, and an unchallenged set of ideas about the virtues of hierarchy. A study of the relationship between political concepts and political action among the Shambaa therefore has more general relevance.<sup>1</sup>

A concern with both political action and the structure of ideas leads one to combine elements of the Weberian sociological tradition, and of the Année sociologique. The study of Shambaa symbols, concepts, and ritual naturally draws heavily on the contributions of the French sociologists. The analysis of the royal capital (chapter vi) as a representation of both cosmology and administrative structure is simply an exercise on a general problem described by Durkheim and Mauss (1963). The study of the rites in which a dead King passed to the world of the ancestors while a member of the royal lineage became King could not have been written before the fundamental discovery by van Gennep of the structure of rites of passage (1960). One of the central problems of this thesis -- the characteristics of the rhythmed time of rites and cosmological conceptions -- was first explored by Hubert and Mauss (1929).

Weber, on the other hand, created ideal types of authority by analyzing the relationship between group action and an 'order' (Ordnung) or normative system (1947: 124n.). His analytical separation between

norms and action is indispensable for the diachronic analysis of political ideas and political organization. In the Shambaa case, simple direct correspondences between changing conceptions and changing patterns of action often cannot be found. This will be discussed at length in the body of the thesis.

I do not mean, here, to perpetuate the stereotyped dichotomy between Weberian analysis, as lacking in subtlety regarding the symbolic content of normative systems, and Durkheimian analysis as lacking interest in innovation and the divergence of behaviour from norms. As Beidelman has observed, the grounds for stereotyped labels lie far more in the works of those who have mined the capital of the classical sociological tradition than in the nature of the founding fathers themselves (1971: 404). While the separation between the normative system and the system of action was central to Weber's work, Durkheim understood and described the partial autonomy of the collective representations. He wrote, in 'Individual and Collective Representations':<sup>2</sup>

Once a basic number of representations has been . . . created, they become . . . partially autonomous realities with their own way of life. They have the power to attract and repel each other and to form amongst themselves various syntheses, which are determined by their natural affinities and not by the condition of their matrix. As a consequence, the new representations born of these syntheses have the same nature; they are immediately caused by other collective representations and not by this or that characteristic of the social structure. The evolution of religion provides us with the most striking examples of this phenomenon. It

is perhaps impossible to understand how the Greek or Roman Pantheon came into existence unless we go into the constitution of the city, the way in which the primitive clans slowly merged, the organization of the patriarchal family, etc. Nevertheless the luxuriant growth of myths and legends, theogonic and cosmological systems, etc., which grow out of religious thought, is not directly related to the particular features of the social morphology. Thus it is that the social nature of religion has often been misunderstood.

Durkheim makes the fundamental distinction here between collective representations and social morphology, as opposed to Weber's less radical distinction between the system of action and the normative system. In the Shambaa case the year to year changes of political leadership and support patterns can best be understood in terms of the separation between the system of action and the normative system. But there has also been drastic change between the autonomous kingdom of the nineteenth century, and the colonial society of the twentieth. To understand this development we need to distinguish the structure of ideas from the structure of social groups. (The evidence for this is presented in chapter viii.)

There are great variations, in different social contexts, in the degree of correspondence between symbolic classification and the social order. One of the reasons societies which practice prescriptive alliance have received so much attention in recent years is that there is a concordance in these societies between symbolic forms and social organization (Needham 1958; 1963). No matter how exact the concordance, it is a truism to say that there are always

behavioural violations of category distinctions, and departures from prescribed behaviour. In a homogeneous cultural and economic setting in the realm of village level descent and alliance the departures tend to be recurrent, and there are established ways of dealing with them. There may be rites, for example, to erase (fictionally) all previous ties of relationship between a man and a woman who are to be married in violation of rules of exogamy. In addition, there is a tension between the system of classification and non-recurrent demographic changes. Whenever the classification of social groups is analogous to cosmological classification, the disappearance of some groups as a result of demographic change leads to change in the relations between terms in the system of classification (Lévi-Strauss 1966: 66-71). Demographic change, however, takes place slowly, over long periods, so that there is not often a forceful demonstration in the realm of experience of the transitory nature of the classification.

When we move to a discussion of kingship, the divergence between experience and an articulated system of cultural ideology is potentially much greater, for two reasons. First, the king (or his councillors) is usually expected to provide leadership at times when new political or economic forces in the region impinge on the kingdom or its subjects. Since historical forces usually affect a large area, and not isolated villages separately, the king as a symbol of the unity of the entire territory is expected to

co-ordinate the responses of his subjects to change. Secondly, the king usually has superior access to the instruments of force, so that when he acts in new and unexpected ways his actions are often not challenged by his subjects. In other words, while most of the behavioural deviations from the expected patterns of descent and alliance are recurrent, with most actors sharing expectations about the range of acceptable social responses to the deviant behaviour, royal deviations are often non-recurrent, and there is less certainty about how to respond to them.

Yet there is the same need in the large scale political realm, as in the realm of village level descent and alliance, for giving order and meaning to experience. And no system of social action can work entirely without mutuality of expectations. In the Shambaa case, constant reference was made, in the practice of politics, to the symbolic order. Competing political leaders attempted to mobilize the support of subject lineages by referring to the political symbols. Because of the wide range of behavioural variation, however, the most important political concepts were extremely general and ambiguous. They lacked precision in their classification of social groups, and in their specification of accepted behaviour. These concepts will be discussed in the body of the thesis.

A concern with the interplay between political leadership and political symbolism makes it necessary to discuss, and to use,

Weber's concepts of legitimacy, power, and authority. Implicit in the view that political leaders redefined the relationship between the symbolic-conceptual system and political action in each generation, is a notion of legitimacy as an aspect of the political process rather than as a quality applicable to total systems, or to statuses within a system (Swartz, Turner, and Tuden 1966: 11).

Legitimacy is a relationship between actions and values. Political leaders choosing between a number of alternative decisions for the allocation of scarce resources (such as positions of authority) establish the legitimacy of a course of action by relating it to accepted values. The alternative decisions can be related to accepted values in a similar way, and often their exponents are active in attempting to establish this relationship -- the legitimacy of their own alternatives. If the anthropologist arbitrarily calls those decisions which are implemented legitimate, he is making a judgement on the relative strength of the relationship between accepted values and the alternative decisions. The decision may, in fact, be implemented not because of its clear relationship to accepted values, but because of the special interests of the decision maker, and because of his superior access to the instruments of force.

Once the difficulty of establishing the legitimacy of any course of action is accepted, and once it is accepted that there are usually competing claims to legitimacy, it can be seen that one of the most

fruitful ways of using the concept is by studying legitimation (Parsons 1960: chapter v), or the actor's attempt to relate his action to accepted values. This approach focuses on the way in which the actors themselves refer to symbols (or values), and keeps the analyst from sinking into a quagmire of value judgements.

The contingent quality of the relationship between values and action is at the heart of the 'ambiguity' which is 'a fundamental attribute of power' (Balandier 1967: 49). Power may be defined as a causal relationship of a particular kind, such that the behaviour of one or more units in a subset (the responsive units), depends in some circumstances on the behaviour of other units (the controlling units) (Dahl 1968: 406-7). Ambiguity enters the analysis at the point where the bases of compliance by the responding units are defined. In any exercise of political power, both legitimacy and sanctions are necessarily brought into play.

Why sanctions? Quite simply, a political decision allocating valued things must be binding. Whether the decision is the award of an office (which is a scarce resource), or the demand that the community's wealth be used for a sacrifice to avert famine, the decision binds the community not to use the same resources in alternative ways. The office may not be awarded to a second candidate. The portion of the village wealth allocated for sacrifice cannot be used for the purchase of food. Bindingness means by

definition that steps will be taken to prevent nonfulfillment (Easton 1959: 226; Parsons 1963).

At the same time that the exercise of power necessarily depends on sanctions, leadership which depended solely on sanctions would usually be clumsy and ineffectual. If the exercise of power were not based in any sense on mutual expectations and shared values, then each minor public act of each individual would have to be elicited by the threat of sanctions.

One of the difficulties in defining political power is that there is an indeterminate, constantly varying relationship, in any action, between coercion and consensus. Parsons has shown that there is always a presumption negative sanctions will be used in the enforcement of binding decisions, but the more those sanctions are actually used, the less effective power is at securing generalized compliance with a wide range of obligations. Hannah Arendt has argued that the Nazis could not have succeeded in the enormous job of destroying the Jews had not Jewish leaders cooperated in rounding up victims in the hope of saving a part of their people. Thus even in this extreme case of the use of force, it is possible to argue that the generality of compliance could not have been achieved without consensus on the value of community leadership (Arendt 1965). In this instance, however, the intense use of force resulted in a high level of compliance; this is quite the opposite of what Parsons

would have us expect. It is necessary, I think, to make a separate class of regimes of terror, in which violence does secure compliance. These would include not only Nazi concentration camps, but also the Zulu kingdom of the Shakan period. (For an extended treatment of regimes of terror, see Walter 1969.) The Shambaa kingdom, however, was not a regime of terror. Shambaa are quite emphatic in asserting that an increase in the level of violence was a sign of the weakness of the King (cf. chapter viii).

It is worth examining the relations between sanctions and legitimacy because at the heart of Shambaa politics there was an interplay between tradition and innovation. With each change in the pattern of action, the leaders referred to the eternal symbols of kingship, in order to restore the sense that events were following their expected course.

## II

There are two major sections of this thesis. The first deals with descent and alliance in the Shambaa kingdom, the second with the symbolic configurations, administrative patterns, and political conceptions associated with kingship. In the first section the kingdom is seen as a territory with a large number of commoner descent groups which were joined to one another by ties of alliance, over which there was a single governing descent group which extended

throughout the entire territory. In the second section there is an attempt to understand what it was tied the level of commoner lineage to that of the chiefly lineage in a single structure. In trying to answer this question I explore the way in which the individual commoner's existential experience of famine, powerlessness, plenty, poverty is related, in Shambaa conceptions and symbols, to political events. Perhaps this will be clearer if I list the chapters and their contents.

After a brief description of the Shambaa land, settlement patterns, and political units in chapter i, there is the first major section of this thesis, on descent and alliance. Chapter ii is a description of Shambaa descent groups, of forms of property and the way they are transmitted from generation to generation, of the characteristics of fission and the resulting distribution of local groups. It is at the same time an historical survey, showing the way in which the politically functioning level of descent groups has become consistently lower (that is, the functioning groups have become smaller) with each increase in centralized political authority over the past two hundred years.

Chapter iii is a description of forms of alliance, including marriage and the blood pact. Shambaa descent groups within neighbourhoods form networks characterized by intense overlapping ties of alliance through marriage and the blood pact. They do so in spite

of strong disapproval of cross cousin marriage, by following a strong preference for marriage between neighbours, combined with a marriage rule which proscribes a great many potential marriages, thus distributing the alliances widely. When the blood pact is combined with marriage the political importance of the alliance is emphasized. The discussion of alliance shows the nature of local level solidarity in a form which is not dependent on the chief as a focus for unity.

Chapter iv is a discussion of descent and alliance among the Kilindi (the royal descent group). There is a description of the way in which the categories and rules which operated in ordinary descent groups were modified for use in the ruling lineage, because the political office which was transmitted from generation to generation within the Kilindi lineage was different from the property transmitted in an ordinary lineage. Marriage alliances were used by Kilindi to gain the support of important commoner lineages.

The King and the chiefs who governed the territories under him were usually related either as father and sons, or as half brothers. In either case there were important implications for the distribution of power between King and chiefs. If the King governed his half brothers, he tended to compete with them. If the chiefs were his sons, he acquired the power of appointment, and the right to intervene in the affairs of the chiefdoms. It is possible to discern a developmental cycle in the Kilindi descent group through a detailed analysis

of the history of the Kilindi lineage in the nineteenth century. The general Shambaa conceptions of the relationship between political action and the welfare of the land (chapter viii, described below) depend, to a certain extent on a cyclical view of the relative centralization of the kingdom. The analysis of the developmental cycle of the royal descent group shows that the cyclical view has an objective basis.

Most of part ii of the thesis is devoted to a study of political symbolism and political concepts. The structure of descent and alliance as described in part i did not adequately explain what tied together the two distinct levels of Kilindi and commoners. There were transitory alliances by marriage and the blood pact between individual Kilindi and particular commoner lineages, but a great many commoner lineages were without such alliances. The more general relationship between the two levels of the hierarchy was defined in terms of the symbols of kingship and chiefship, and the conceptions of the effects of political action on rain, crop pests, and the general level of violence in society.

Chapter v is a study of the rites which took place at the time of the death of one King and the accession of another. The death of the old King was hidden until the moment his successor was acclaimed at the royal capital. The public experience of kinglessness was shaped by the rite, and the experience of competition

between potential heirs at this time was suppressed. Yet Shambaa recall the details of this competition in their historical traditions. It is clear that the sense of rhythmmed time created by the rites and the linear time of the traditions are complementary.

The rites separated one potential successor from a group of essentially equal half brothers, and made him King by transferring the regalia to him as he reenacted the myth of the founding hero King. When the new King had entered the royal capital, the people of the surrounding area greeted him with a number of set phrases which set out in dramatic form the Shambaa understanding of the power of the King, and the tensions which could develop between the King and his councillors, or between the King and the ordinary commoners. An examination of the attributes of the founding hero King, and of the set phrases in the public acclamation, contributes to an understanding of some of the major symbols of kingship, and of the Shambaa view of possible characteristics of relationships between King and subjects.

Chapter vi is a description of Vugha, the royal capital. It is said that the details of Vugha's construction had been set out by the first King, and that they could not be altered. Vugha was a concrete representation of the world of the Shambaa, with different sections of the capital corresponding to different portions of the kingdom. At the same time it was an administrative diagram,

for the officials who acted for the King in the various portions of his realm lived in the appropriate sections of Vugha. The relationship between King and subjects was also represented in the plan of the capital. Different building materials were prescribed for the houses of the King and the commoners. The place of the royal court in the larger capital was also significant.

The graves of the earlier Kings and the magical charms for rain and for success in warfare were located at the heart of the capital. It is possible to learn something of the place of the royal ancestors in the life of the kingdom by examining the characteristics of the grave site, and the activities which were performed there.

There is an additional problem of the relationship between the unchanging form of the royal capital and the changing patterns of political action. The place of Vugha in Shambaa history is examined, and it is shown that Vugha's place in Shambaa politics changed, and that there were subtle shifts of content, while the form remained relatively static.

Chapter vii is a study of litigation, warfare, and tribute -- three activities in which the existence of the state impinged upon the practical concerns of the subject lineages. It is possible, by studying these three, to understand the variability of power relations between King and chiefs. A chief who was dominated by the King paid tribute, came to the help of the King in war, and

could not impose a settlement by force in an interlineage dispute but rather sent the case on to the court of the King. On the other hand, any chief who retained independent power imposed settlements in interlineage disputes, did not need to help the King in war, and did not pay tribute to the King.

I have already mentioned that in the chapter on the royal capital, and in that on succession rites, I examine the symbols which express the characteristics of kingship. The symbols are powerful ones which express ambiguity and ambivalence, for the King's power can be used to bring life or death to his subjects. In chapter viii I explore indigenous discursive statements explaining the way in which certain kinds of political actions bring fertility to the land and increase life, while others bring famine and death. The chapter discusses at length two concepts which are crucial to any understanding of the political ideals of the Shambaa: to break or harm the land (kubana shi), and to repair the land (kuzifya shi). The King was thought to repair the land when he dominated the chiefs, so that they paid tribute, supported him in war, and sent him difficult cases. When this happened there was little violence, the subjects were not impoverished by the depredations of the Kilindi, and there was a 'feminine farming season,' that is, a fertile one. The land was broken when there was competition among leaders, and when counter-spells were used to hold back the rain, producing a 'masculine farming season,' or famine.

After a study of the two concepts, there is a review of the politics of rain magic over the past century, and of the way in which Shambaa interpret the actions of past leaders in terms of repairing and breaking the land. It is shown that while the categories have probably existed since the founding of the kingdom, the political actions they refer to have changed drastically.

Given the scope of the problem discussed in this thesis, it is very difficult to achieve a satisfactory balance between structure and action. I attempt to solve this problem in two ways. First, in the chapters which are most important for an understanding of the symbols associated with kingship (the chapter of succession rites, and that on the capital) I try to describe the changing uses of the symbols or rites, and their changing content.

Secondly, in the concluding chapter of each major section of the thesis, I include a moderately detailed case study. In chapter iv, which is on Kilindi descent and alliance, I describe the politics of royal descent and alliance for most of the nineteenth century at length, so that processes of descent politics can be examined with loose ends showing. In chapter viii, on the central concepts of Shambaa politics, I describe the application of those concepts over a period of a hundred years. In each of the case studies (which overlap) it is possible to see the range of variation

in patterns of political action, and the relations between the system of action and the symbolic-conceptual system.

### III

The need for historical ethnography in this work should be clear from the discussion to this point. It is impossible to study the changing relationship between political action and political symbols and concepts without a time perspective of some depth. Historical study is of particular importance in an analysis of the politics of kingship. While a student of particular marriage forms can observe a large number of marriages distributed through space, the student of kingship is limited to one observable king. The others are distributed over past time.

Most of the body of this work, however, is not a description of kingship as it exists at the present, with evidence extending back into the past, but rather as it existed before 1890. In defining the scope of this ethnography I have departed sharply from most current usage, which (quite soundly) is strongly tied to the present.

Over the past ten years anthropologists have become increasingly acute in identifying 'the fallacy of the ethnographic present,' in which institutions are described not as they currently exist, nor at an identifiable point in the past, but merely as traditional institutions, unaffected by modernization (Smith 1962). The response

has been for more recent ethnographers to root their research firmly in the present, with all its complexities. As research focuses more and more on the present, however, some kinds of comparative data are being excluded from consideration because they do not exist at the current time. It is virtually impossible today to observe the workings of an autonomous non-literate kingdom in a non-money economy. Anyone interested in this kind of society, as I am, must resort to historical study.

There is a difficult methodological problem, however, in describing past social structure. In a field which has relied so heavily on participant observation, the methodological problem would appear insurmountable, were it not for the fact that in the past ten years there has been a flowering among historians in the study of the indigenous history of Africans, along with the development of an array of methods for studying the history of non-literate societies, in situations where written documentation does not exist (Vansina 1965; Smith 1960; Vansina, Mauny, and Thomas 1964; Vansina 1968; McCall 1969; Gabel and Bennett 1967). The present author has discussed materials and methods for the reconstruction of the record of political action at length in another work (Feierman 1970).

Because this thesis was planned as a study of a problem in social theory, and not as an exercise in any particular kind of historical method, a great variety of methods are used, each adapted

to a particular problem. There is one method for discovering some of the characteristics of eighteenth century descent groups, another for reconstructing the plan of the capital as it existed in the mid-nineteenth century, still another for learning the precise descent relations between the King and his chiefs in the first half of the nineteenth century. It would be tedious for me to list here all the unrelated bits of historical reasoning. Instead, I describe, at an appropriate point in each chapter, and sometimes in each section of a chapter, the methods which I use for reconstruction of the ethnographic past. The descriptions of method and of evidence are sometimes included in the body of the text, and sometimes given in extended footnotes.

## FOOTNOTES

<sup>1</sup>I am not arguing here that Shambaa boundaries are rigid and completely unambiguous, only that the relationship between conceptions and change cannot be explained in this case with reference to boundaries.

<sup>2</sup>The significance of this passage from Sociology and Philosophy (1953: 31) was discussed in Robert Bellah's article, 'Durkheim and History' (1964).

## CHAPTER ONE

### THE SHAMBAA AND THEIR LAND

There are over 200,000 Shambaa, most of whom live in the mountains of north-eastern Tanzania which they call 'Shambaai,' and which others in Tanzania refer to as West Usambara.<sup>1</sup> The escarpments of Shambaai rise steeply out of the surrounding plains to an altitude of 4,000 to 5,000 feet, and because of the relationship between high altitude and high rainfall, the mountain block is like a green island in a brown sea. Standing at the top of the escarpment, with one's back to the plains, one is faced with a succession of valleys and peaks stretching to the horizon, with the highest peak well over 7,000 feet. The Shambaa, who live largely by hoe cultivation, with some stock raising, are forced by the absence of flat plateau land to farm the hillsides. Land is scarce; the entire mountain block has less than 900 square miles, much of which is forest reserve or too steep for use (Attams 1967: 19).

The Shambaa have a strong sense of their own ethnic identity. There are two bases of the definition of the ethnic group. First, the Shambaa are the people who live in 'Shambaai,' which, besides being the name of the mountain block, denotes a kind of ecological setting. When pressed to define Shambaai, the Shambaa name a number of plants which are found in the mountains, but not in the

plains. The lowlands, which are called nyika, have their own characteristic plants. None of the plants which indicate nyika are found above about 3400 feet; no indicators of Shambaai are found below about 2100 feet. Between these two altitudes the plants of nyika and Shambaai are mixed, with a predominance of mountain plants in the higher altitudes, and of plains plants at the lower ones.<sup>2</sup>

The second basis of the ethnic unity of the Shambaa is a cultural one. The Shambaa are people who speak the Shambaa language (one of the Bantu languages), and who perform Shambaa rites. The Shambaa language is remarkably rich in vocabulary for describing the environment of Shambaai, and rites of passage include instructions for the initiates on the use of that environment. The cultural basis of Shambaa ethnicity is therefore congruent with the environmental basis. Some Shambaa, however, have always lived in nyika -- in the lowlands. They have continued to call themselves Shambaa if they have retained Shambaa language and culture, and if most of their ties of descent and alliance have been with other Shambaa. But often people who have moved permanently to the plains have changed ethnic identity and become Zigula. Conversely, the ancestors of some of today's Shambaa were Zigula who moved to the mountains.

The conjunction of the two criteria of Shambaa ethnicity -- mountain environment and Shambaa culture -- are used by the Shambaa to distinguish themselves from all their neighbours. The Pare, who lived in mountains to the northwest of Shambaai, live in an environment very similar to that of the Shambaa, and raise many of the same crops, but they can be distinguished by their culture. The Zigula, who live in the plains immediately south of Shambaai, have a language which is almost intelligible to Shambaa speakers, and perform many of the same rites but live in a completely different environment. The Bondei in the foothills to the east, are similar in language and culture to the Shambaa, but live in a different kind of environment. The people of East Usambara (who live between Bondei and Shambaai) are often called Shambaa, although just as often they are described as Bondei, because of their separation from the main mountain block across the Luengera Valley.

The Shambaa and their immediate neighbours have based their agricultural practices as well as their ethnic boundaries on a regional distribution of rainfall in which there are great local variations. At Mombo, in the plains, at the border between the Shambaa and the Zigula, there is an average annual rainfall of 25 inches. At Lushoto, on the dry western side of Shambaai, less than ten miles from Mombo, the annual rainfall is 42 inches. And at Baangai, a bit more than ten miles from Mombo, on the wet eastern

side of Shambaai, the average annual rainfall is 68 inches (Attems 1967: 148).

Shambaai has always been more heavily populated than the Zigula plains to the south, because its rainfall has been much higher. The plains to the north of Shambaai have been largely unoccupied, because they are too dry for cultivation, except at the foot of the mountains, which is watered by the run-off from the mountains. The rainfall in Bondei is quite high, because it is the first hilly area struck by winds from the east, but because it is lower in altitude than Shambaai, the temperatures are higher. It is important to note that when the Shambaa kingdom expanded in the late eighteenth and early nineteenth centuries, it expanded eastwards to heavily populated Bondei, rather than southwards to sparsely populated Zigula.

My statement here, about the relatively dense population of Shambaai, directly contradicts the observation of Oscar Baumann, a nineteenth century explorer who estimated after a brief visit that Shambaai had a population density of 3.8 per square kilometre (1891: 13). There are a number of reasons this estimate is unacceptable. First, Baumann estimated the area of the mountains as about 1800 square miles (4620 square kilometres), about twice what it actually was. Secondly, Baumann had decided that Shambaai had excellent land for white settlement, and he was making the argument that no population

would need to be displaced if settlers came. Events proved that he was wrong. By 1913 there was extreme land shortage for indigenous cultivation in Shambaai as a result of white settlement.<sup>3</sup>

Thirdly, during the time of Baumann's visit the Shambaa built their villages in inaccessible areas which could not be seen from the main footpaths, so that invading warriors and slave raiders would not find them. The villages were hidden, surrounded by thickets or banana groves. A number of Europeans who settled in Shambaai at the time, and got to know it well, reported their surprise at finding that areas which they had assumed to be completely unpopulated were found, after long acquaintance, to be richly settled (Holst, 1893: 113; Karasek 1911: 155; Dupré n.d.: 62).

Fourthly, Baumann estimated that the entire population of the chiefdom of Mlalo was 3000 (1891: 179). F. LangHeinrich, a missionary with long and intimate acquaintance with the area, estimated that when the war drum was beaten at Mlalo, 3,000 armed men would assemble; some, admittedly, came from neighbouring chiefdoms, but other young men would have remained home to guard their villages, and older men did not respond to war drums (1913: 71).

Fifthly, in the pre-colonial and early colonial period there was a great scarcity of firewood on land which had forest as its natural cover. In 1852, almost forty years before Baumann wrote, Johann Krapf observed that firewood was very difficult to find in

many parts of Shambaai (1964: part 2, 297). The population of the royal capital (Vugha) dispersed very soon after colonial conquest, but it was reported in 1914 that it was impossible to find firewood within a mile and a half from the center of Vugha.<sup>4</sup>

Finally, in the rules of land tenure of the pre-colonial Shambaa, land was treated as a scarce resource. A man who cleared a piece of bush or forest land had permanent possession of it, even if he left it uncultivated for a number of years. Land could be, and was, bought and sold. Both the historical traditions and one of the earliest missionaries to settle among the Shambaa agree on these points (Wohlrab 1918: 174).

The Shambaa speaking population was not spread evenly over the entire area of the mountains. There were some areas which, while relatively fertile and with good rainfall, were not occupied by Shambaa. The areas preferred were all near the edges of the escarpment, around the outer rim of Shambaai. The Shambaa prefer to live in areas where nyika is easily accessible. Shambaai is thought the best place to reside, but the Shambaa economy depends on the use of the resources of nyika. This pattern is one of great stability over time. The earliest known Shambaa groups lived at the rim of the mountains. At some time, probably in the early eighteenth century, the semi-pastoral Mbugu people moved into the high central area of the mountains, but they did not displace

Shanbaa: they occupied a niche in the environment which had been empty until that time (Feierman 1970: 75-96).

The entire 'land' (shi, s. and pl.) of Shambaai was divided into units, each of which was called a 'land' in its turn. Virtually every major 'land' was located at the edge of Shambaai so that it possessed territory in both the Shambaai and nyika zones. If one ignores local variations in order to describe the boundaries of the 'typical' land, one would say that the boundaries which separated each land from others of the kingdom ran up and down the escarpment, while the boundary closest to the centre of Shambaai separated the land from Mbugu territory, and the boundary which ran along the base of the mountain separated the Shambaa from the Zigula. The boundaries were carefully remembered. Natural features were supplemented by such man made markings as axe heads driven into trees. In one defensive war rite, the officials of the land would lead a cow around the boundaries.

As I have indicated, there is no terminological distinction in the Shambaa language between the 'land' of Shambaai and its constituent units. In addition, every territorial ruler has the same title: zumbe, or 'chief.' The ruler of Shambaai is called zumbe; the ruler of a major constituent land is called zumbe; the ruler of a small sub-unit of that land is zumbe. I shall demonstrate in chapter vii the sense in which this lack of terminological

distinction is appropriate, for there were times when the ruler of a major unit was, in the absence of a powerful King, the head of a sovereign territory. There are, however, ways in which Shambaa make distinctions among rulers of different levels. The King had the title Simba Mwene, which could not be used by any of the chiefs. When referring to the King, Shambaa use the terms Simba Mwene and zumbe interchangeably. Territorial rulers at different levels in the hierarchy had different powers (see chapter vii); these were communicated in Shambaa discourse, in the absence of title distinctions, by references to the names of the territories, which were generally known. In order to simplify descriptions of political organization I shall use the term 'King' as a translation of Simba Mwene, the term 'chief' for the governor of any major unit who was expected to be directly responsible to the King (that is, the governor of any chiefdom), and the terms sub-chief and sub-chiefdom for lesser units subordinate to a chief. The King was expected to rule over all the chiefdoms through the chiefs, but in addition he ruled the chiefdom of Vugha directly. Similarly, each chief governed through sub-chiefs, and yet retained direct control of the sub-chiefdom surrounding his capital.

There were two kinds of settlement within each land. First, there was a political capital -- a royal village or town. Secondly, there were the villages of commoners. The Shambaa use the word mzi

(pl. mizi) to refer to any kind of village or town, royal or otherwise, but they can also make distinctions, in the appropriate contexts, between the 'court' of the chief (kitaa, pl. vitaa) and the villages of commoners (kiambo, pl. viambo). Kiambo is also the name of a cluster of wild sisal. One Shambaa, in explaining this to me, explicitly compared the cluster of houses with the cluster of sisal leaves.

Every head of a localized subject lineage was required to maintain a house at the royal village or town nearest to his home village. The letter of the law (which was often ignored), required that every house in a royal village be occupied every night. A subject whose house in the royal village or town was empty at night could be fined a goat. Some towns were quite large. Burton and Speke, the explorers who saw Vugha in 1857, estimated that the town had 500 houses (1858: 211). At the beginning of the colonial period it was estimated that Mlalo, a town in the north, had 220 houses. Bumbuli, in the east, was said to have 180 houses (Dupré n.d.: 62).

Because of this residence pattern, every localized lineage needed to maintain a garden near the capital in addition to its other gardens. The capital itself possessed land, so that the chief, who wanted as many people as possible to live there, could give farms to new subjects. There was an official at each court

(the mkauzi) who administered the lands, which were called kitaa (the court land) or ngao (the shield). Unlike ordinary land, which was held permanently, and could be disposed of, the court's land always remained under the control of the chief. The person who farmed there could be removed, and if the land was left uncultivated it could be given to another subject. I observed a dispute at Vugha, in April 1967, over a piece of land which had been court land in the pre-colonial period. About thirty years ago, the man who had farmed the plot allowed an acquaintance to farm there in his place. He was now suing for the return of his land. The informal court, presided over by the local chairman of TANU (the Tanzania African National Union), ruled that the original farmer was mistaken in regarding court land as his personal disposable property.

Bananas were the most important crop on court land. (Musa acuminata, Musa balbisiana, Musa paradisiaca, and bananas of the Ensete family). In the banana groves of Shambaai, the shoots continuously reproduce, and so the groves are virtually permanent (Attems 1967: 79). A cultivator could spend most of his time farming in his village, and yet maintain a supply of food at the capital. As a result, most of the royal villages of Shambaai were surrounded by banana groves.

Even when it was possible for a man to support his dependents in town, it was considered extremely unwise to do so. Every man needed a home village. If one kept goats and cows at the capital they would surely be coveted by someone powerful. The capital was considered an inappropriate place to bring up young children, or to care for a woman who had just been through childbirth (cf. chapter vi).

Shambaa villages are (and were throughout the nineteenth century) placed along the tops of ridges, or stretched along the upper sections of hills; they are never in valleys. As additional men move into a village they extend it along the ridge, and each uses the strip of land extending downward from his homestead for banana gardens, often with some tobacco. Usually a man has a house for each of his wives, and all his houses are grouped together. In the nineteenth century, there were extra houses for the unmarried children of the village who were considered too old to sleep regularly in their mothers' houses (older than about eight years). This was called a bweni. Today the boys' bweni survives in some places; in others each man has an additional house for himself and for his sons. In still other cases, the women of a household simply move around every night, leaving one house empty for the boys.

Most Shambaa clearly enjoy the sociability that is a part of living together in large villages. Often the people of a village decide spontaneously and casually to take an evening meal communally (kuja ndaa). The men and boys usually eat separately from the women and small children, and at the time of a communal meal, all the men and boys of the village gather together, and each woman brings a dish of food. Each man then eats a bit from a number of plates. The women, meanwhile, are eating together in another part of the village. At all times, except in time of famine (saa), men feel free to drop in at one another's houses for dinner, and they very rarely eat alone. Women can often be seen carrying baskets of food back and forth between the houses. Shambaa is a very pleasant and open place in which to do field work.

It is a remarkable feature of Shambaa spatial distribution that a village, once established, survives for very long periods of time. There are literally hundreds of villages all over Shambaa which are occupied today, and which can be shown to have existed a century ago, or even two centuries ago, or longer. The existence of these villages at specific points in the past can be demonstrated by referring to historical traditions which are not merely bald statements that a given village existed a long time ago, but detailed descriptions of events which occurred there. The permanence of many

Shambaa villages is demonstrated by the list given in fig. 1, of villages in the chiefdom of Vugha which can be shown to have existed more than 100 years ago, and which still exist today. Similar lists could as easily be made for the other chiefdoms of Shambaa.

Village	Conservative Estimate of Demonstrable Date	Source
Ziai	1700	Historical traditions: Makao Sangoda, Idi Kibarua, Selemani Shebawa (group testimony), 10 May 1967; Idi Kibarua, 30 October 1967.
Kidundai	1750	Historical traditions: Mbwana Mkanka Mghanga, 7 May 1967; Shemaenze, 9 May 1967.
Kihitu	1750	Historical traditions: Kimwei Magogo, 24 March 1967; Makao Sangoda et al. 10 May 1967; Kasimu Kimweri, 1 February 1968.
Kighuunde	1820	Historical traditions: Mhammadi Kika, 20 April 1967; Mbwana Mkanka Mghanga, 7 May 1967.
Mponde	1790	Historical traditions: Nkinda Kimwei 6 June 1967; Kimwei Kibanga, 3 June 1967. Krapf 1964; part 2, 297.
Mkumbaa	1850	Historical traditions: Mbwana Mkanka Mghanga, 13 November 1967.
Manka	1850	Abdallah bin Hemedi'lAjjemy 1962: sura 42. Waziri Nyeghee, 1 July 1967.
Kishewa	1750	Historical traditions: Kimweri Magogo, 3 April 1967; Ng'wana Aia, 20 March 1967.

Village	Conservative Estimate of Demonstrable Date	Source
Mpangai	1800	Historical traditions: Mbwana Mkanka Mghanga, 13 November 1967; Mwokechao Gila, 10 August 1967.
Shashui	1750	Historical traditions: Mdoembazi Guga, 15 June 1967.
Mbuzii	1850	Historical traditions: Mhammadi Kika, 20 April 1967.
Nkoongo	1850	Historical traditions: Salehe Mwanbashi, 29 March 1967.
Mziyasaa	1800	Abdallah bin Hemedi 'lAjjemmy 1962: Sura 31.

The point being made here is not merely that some village of Shambaai are very old, but that large villages, once established, are regarded as permanent. The villages which have been established during the past 70 or 80 years are clearly not expected to break up, or to move, or to disappear. The reason the Shambaa differ in this respect from so many African peoples (the Ndembu, or the Gogo, for example) whose villages change location with great regularity, is that the Shambaa do not spend most of their farming time near their homes. The farm plots of a typical Shambaa are scattered at a number of points within about a five mile radius of his village. Each Shambaa household must rely on farm plots which are distributed over a wide range in altitudes, up to the high peaks, and down to

the foot of the escarpment. The most important requirement in locating a village, then, is that it be at a mid-point, between the mountain peaks and the plains. It has already been shown that most Shambaa live around the edges of Shambaai, in the one zone which is at the mid-point.

Shambaa live at the mid-point in order to take advantage of the variations in temperature and rainfall which are related to altitude. There are three rainy seasons in Shambaai: ng'waka (March to May), vui (October to December), and muati (August). The August rains fall only high in Shambaai. Ng'waka is brought by trade winds from the south-east, which blow against the mountains, rise, cool, and deposit their moisture. As a result, the highlands have higher rainfall than the lowlands, and the south-eastern part of the mountains is wetter than the north-west. During vui the trade wind comes from the north-east, bringing the most important rains of the northern rim of Shambaai. Most farmers attempt to use local variations in order to farm during all three seasons, so that they can make full use of their potential labour time, and so that they can maintain a supply of food through the entire year.

Some crops grow in both the nyika lowlands and in Shambaai, but have different growing cycles in the two zones, because of the different climatic conditions. The most important of these is maize, which was widely grown by the middle of the nineteenth

century (Burton and Speke 1858: 211, 214; Krapf 1964: part 2, 114). Maize grows more quickly in nyika than in the cool mountains. This means that in a year of heavy but short rains, the maize crop of nyika could survive while the Shambaai crop failed. Maize is (and was) planted only once a year on any given plot; for each of the three rainy seasons there are preferred plots, and so any single cultivator must move over a wide area and a wide range of altitude if he is to work and eat all year.

There were special uses for each of the three zones (nyika, Shambaai, high Shambaai). Shambaa maintained (and still maintain) plots high in Shambaai, because it is only in this zone that the August rains (muati) are sufficient for cultivation. There were some products which were necessary for subsistence, which could only be obtained in nyika. These included manioc and sorghum.<sup>5</sup> Game meat, which was an important part of the Shambaa diet in the nineteenth century, but which is now not easily available, could only be obtained in nyika. Some crops, of which bananas and sugar cane were the most important, were grown almost solely in Shambaai.

Wherever they farmed, people preferred to live in Shambaai because the mountain villages were relatively secure against raiders, because of the higher and more regular rainfall, and because they associated nyika with disease: mbu was the word for both mosquito and malaria, and it was recognized that the two, which were absent

in Shambaai, were characteristic of nyika (LangHeinrich 1921: 259; Koch 1953).

The way in which the residents of Shambaai have ordered their relationships with nyika has changed over the years. Since the beginning of the colonial period it has been easy for small groups of Shambaa to live in nyika. In the neighbourhood survey which I conducted at Vugha in 1968, a little less than half the men I questioned had farms of their own in nyika. Of the men who did not farm in nyika the great majority had either blood partners or close patrilineal relatives who lived in nyika, and who would probably have sold the products of nyika to them on reasonable terms, even when a partial crop failure in Shambaai led to high prices at the market places. Only 13% of the men questioned had no access to the crops of nyika.<sup>6</sup> Both oral accounts and a mass of documentary data (cf. Feierman 1970) show that when there was less security in the plains, before the beginning of the colonial period, few Shambaa lived in nyika. Many walked from their homes in Shambaai to their farms in nyika.

The practice, among Shambaa, of living at a middle point and walking to dispersed garden plots, made it possible for a single individual, or a localized lineage, to maintain plots in the particular locations which were suitable for dry season farming, or for farming in time of drought. There were (and are) irrigated

plots in Shambaai fed by ditches which were often miles long.<sup>7</sup>

During dry periods, Shambaa also farmed in drained marshes.

The livestock of a Shambaa husbandman are often as widely dispersed as his farming plots. In the pre-colonial period men feared that if they appeared wealthy their herds would be taken as tribute, and so they put their cows and goats in the care of others. The practice of spreading one's livestock among a number of villages persists. A man with many debts would never keep his livestock at home, where they could be seized. If there is a dispute over the ownership of a particular cow, or over the division of bridewealth, it is considered wise for the disputants to move their livestock to other villages, so that the animals will not be ensorcelled. In cases of localized outbreaks of disease, all of one's cattle do not die if they are not all in one place. The person who cares for another's livestock gets the milk and some of the offspring.<sup>8</sup>

The large permanent villages were residences: each day its members would go out in all directions -- to the capital or to nyika, to check on a pregnant cow in another village, or to drain a marsh. Most daily activities could be carried out within a radius of about five miles: the distance from the centre of a typical large chiefdom to its borders. I suspect that each chiefdom was a living economic entity tied together by the daily movements of the people who lived in it. The requirement that each localized

lineage occupy a house at the nearest capital provided a focus. This view of the chiefdom as the territory within which individuals moved each day, starting from their villages in the morning and returning in the evening, would explain why the borders of the chiefdoms continued down into nyika even when there were no villages there. I have shown elsewhere that neighbourhoods very much like the chiefdoms had existed before the kingdom was founded (Feierman 1970: 76-87). The argument has remained tentative in tone in spite of all this evidence because I have no clear idea whether many people lived near the borders between chiefdoms, or whether those who did farmed in two chiefdoms, on both sides of the border. Even today, one gets the impression that population is much denser near the centre of the old chiefdoms than it is around the edges.

The wide dispersal of garden sites was (and is) intended, quite consciously, to reduce the possible effects of crop failures. Any failure which was local in distribution or brief in duration was compensated for by the overlapping growth cycles and the scattering of plots. There were, in spite of all these precautions, frequent disasters. The subtle planning of the Shambaa cultivators was defeated by the swarms of locusts which appeared at intervals which were all too frequent.

Drought was a cause of serious famine in this setting if it was general, and not limited to a single altitude zone. It was especially serious if it continued for more than one sowing season. While the Shambaa grew enough maize in a very good season to last through several seasons, it could not be stored for very long. It was stored in a kind of attic (taai) directly over the cooking fire. The smoke from the fire kept off insects and helped to preserve the maize, but there was no defense against mice. The problem of mice was even worse in the pre-colonial period than it is now, because the beehive hut with thatch down to the ground, (which was then the most common kind of house), was easy for vermin to enter. The only adequate way to prepare for famine was to plant root crops which could remain in the ground for long periods, as a self-storing reserve. Manioc, which was planted in the lowlands, could be left in the ground for up to four years (Attems 1967: 60). In Shambaa maeze (Xanthosoma violaceum), viungu (Dioscorea bulbifera), and majimbi (Colocasia antiquorum) were kept in the ground for use in case of famine.

No preparations were adequate for a time of severe famine. Shambaa traditions, confirmed by the records of the missionaries who lived through the great famine of 1899, tell of people eating the roots of the banana plants, and the peels of the bananas. There is a poisonous wild yam which with careful preparation could be,

and was, eaten (ndigha -- Dioscorea dumetorum).

The names of the pre-colonial famines tell the story of just how desperate life was at these times. There was kija nkingo -- 'the leather eating famine; there was siafu -- 'the famine when biting ants were eaten;' there was the famine of myime afe, which means, 'refuse to help, let him die.'

In addition to the famines which were general in their distribution, there were local shortages which occurred virtually every year in one place or another. The Shambaa word saa ('hunger') is used to refer not only to the occurrences in which there is loss of life, but also to any crop failure which leads to a diminution in the supply of food. It also means hunger, as the individual's sensation occurring every day before meal time. Saa is thus closest in its range of meanings to 'hunger' in the old English usage.

Trade was especially important during a local famine. People from the hungry areas would attend markets in regions which were well supplied, or they would visit their kinsmen and blood comrades in order to buy food. Cows, goats, sheep, and hens were exchanged for quantities of staples. Most frequently a man buying substantial quantities of starch to feed his dependants would sell a goat. The price was determined by supply and demand.<sup>9</sup>

Livestock were acquired by natural increase of existing stock, as bridewealth, and for sale of cereals. In addition, Shambaa

specialists were usually paid in livestock, or they converted their earnings to livestock, which was the most important form of moveable property. Thus the blacksmith who reduced iron, or more frequently worked iron which he bought from the Pare, the medical specialist, the hunter (who sold the meat of each kill), the proficient warrior (who was rewarded with livestock), and of course the chief, were more likely to survive famine than their less fortunate neighbours. Other men could acquire livestock by selling excess staple in a good year, or more frequently by selling tobacco, for Shambaa tobacco was purchased over a very wide area of what is today Tanzania as well as Kenya. But the tobacco farmer never became wealthy like the specialists. There is a Shambaa proverb: Muima gaga, ni ukiwa, 'tobacco farming is poverty.' There is another proverb in which the Shambaa acknowledge that specialists invariably take livestock which, like blood, is essential for the maintenance of life (cf. p. 94); it is one they apply to chiefs as well as medical practitioners: Waghanga wosheni waavya mpome -- 'all doctors draw blood.' A final admonitory proverb, on the importance of non-farming pursuits for maintaining one's dependants, says Vimba vingi ni vya ushoi -- 'many corpses are results of poverty [in moveable property].'

## FOOTNOTES

<sup>1</sup>According to the Tanganyika Population Census, 1957 (Nairobi, 1958), there were in 1957, 194,000 Shambaa. The population has been growing rapidly since then. The Shambaa are also known by the names Shambala, Sambaa, Sambara.

<sup>2</sup>For a more detailed description of nyika and Shambaa, and a list of some of the plants, see Feierman 1970: 19-25.

<sup>3</sup>Tanzania National Archives, Wilhelmstal, 'Kronland (Generalia),' no number, 8 April 1913.

<sup>4</sup>Nachrichten aus der ostafrikanischen Mission, January 1914, p. 3.

<sup>5</sup>These two crops were mentioned by Burton and Speke (1858: 211), and in Steere's Shambaa wordlist (1867). Buchwald mentioned that neither crop would grow in Shambaa (1897: 85).

<sup>6</sup>For precise figures, see Feierman 1970: 28-29.

<sup>7</sup>There are oral traditions about descent groups which moved in droughts in the eighteenth century in order to be nearer the irrigation ditches.

<sup>8</sup>Wohlrab 1918: 176; Dupré n.d.: 50. For reasons which are not clear, the Shambaa breed of cattle changed during the nineteenth century. Today, all Shambaa cattle are humped Zebu. But Krapf reported that in 1848 almost all Shambaa cattle were humpless. Dupré's informants confirmed this (Krapf 1964: part 2, 125; Dupré n.d.: 21).

<sup>9</sup>Famine is described in great and specific detail in the oral traditions.

PART I

CHAPTER TWO  
DESCENT GROUPS

This chapter is a survey of the full range of Shambaa descent groups of varying span and genealogical depth, and at the same time it is an account of the changing uses of descent groups over the past two hundred years. As the survey moves from groups of the greatest span to those of the smallest, the historical account moves from the days before the creation of the kingdom to the present time. The argument presented here is that with each increase in the intensity of centralized political dominance on a territorial basis, there was a corresponding decrease in the span and genealogical depth of the descent groups which carried the greatest political weight. The study will show that with the creation of the kingdom, there was a decrease in the corporate political activity of large groups based on putative descent (which I call clans), resulting ultimately in the disappearance of clans in some places, and of the role of clan leader in virtually all places. Through the years when the autonomous kingdom was well established, patrilineages of about seven or eight generations (from young child to apical ancestor) were treated as the crucial jural and political groups. With the establishment of European rule there was a decrease in the frequency of corporate action by these large span lineages, and a greater emphasis on the jural importance of the unit consisting of a father and his young

children. In spite of the changes in the uses of descent groups of varying span, the descent structure at all levels has survived.

There is a serious translational problem to be faced in a discussion of descent groups. There are two ways in which Shambaa distinguish among descent groups of varying span. First, there are a number of categories in the Shambaa language which designate descent groups. Second, there are jural rules and accepted standards of behaviour which apply to groups at particular levels of segmentation. The problem is that the linguistic categories are all terms with relatively wide ranges of meaning, each of which may be applied to a number of levels of segmentation and span. The jural rules, on the other hand, are often quite precise, in referring to a single level.

One example, of the many discussed below, will illustrate the problem of definition. The term chengo (pl. vyengo) is used to denote a patrilineage, within which real ties of relationship can be traced, at any level of segmentation. It is possible to speak of the two grown sons of Kimea as chengo cha Kimea, 'the chengo of Kimea.' It is also possible to speak of Kimea and his brothers and half-brothers as a single chengo, and similarly of a large group of men, spread over several chiefdoms, and descended from a common great-great-grandfather (through agnatic lines). There are clear and precise rules that everyone within the chengo in its largest sense must be called at the time widows are inherited, but that wealth may

only be inherited within the chengo in its smallest sense. The rules can be precisely stated in Shambaa, by explaining at length the kind of chengo one means. But there is no single word to denote any particular level with precision. And so it is necessary to resort to orthodox anthropological terms, including clan (defined in section i), maximal lineage (defined in section ii), medial lineage (defined in section iii), and minimal lineage (section iv).

This analysis is based on four kinds of data. First, there are the records of my own observations in Shambaai, which cover the full range of normal ethnographic field work, from noting gossip to making a census. Second, there are relatively rich written records on Shambaa social organization during the first decades after colonial conquest.\* Third, there are the reminiscences of old men, which

---

\*There is a profusion of published and archival sources, far too many to list completely here (but listed in the bibliography). The most important include: LangHeinrich 1903, Wohlrab 1918, and Karasek 1911-1924. LangHeinrich's article was written as an answer to a questionnaire sent by S. R. Steinmetz for a study on comparative law. The article was completed by May 1896, at a time when LangHeinrich, a Lutheran missionary, felt that he had not yet fully understood Shambaa social structure. As a result, he completed the questionnaire with the help of an adult informant at Vugha. Wohlrab, another Lutheran missionary, had arrived in Mlalo in 1891, before effective German government had been established there, and had worked in the Shambaa language for over 20 years before he wrote his account of Shambaa law. Karasek was a planter who lived with a Shambaa woman. His account was published from his notes posthumously. It does not give a full description of social structure, but is magnificent in its description of the minor rituals and magical usages of Shambaa marriage. The works of LangHeinrich and Karasek were edited by men who did not know Shambaa, working undoubtedly from the longhand manuscripts. As a result, in both these works the materials given in the Shambaa language are garbled, often beyond recognition. In LangHeinrich's work even the author's name was incorrect: it was given as Heinrich Lang.

describe both norms and actions before conquest. Fourth, there are the traditions preserved by descent groups of events in the distant past. The validity of these can be assessed through the use of carefully controlled inferences on the distribution of varying forms of descent organization, and on the distribution of oral traditions. The descriptions depend, to a certain extent, on the fuller analysis of historical evidence in Feierman 1970. My concern here is to present a coherent analysis of the descent structure, rather than a technical study in historical reconstruction.

## I

The largest descent groups, and those which had their important role earliest in the history of Shambaa social organization, are called clans in this work. Clan is not intended here as a precise descriptive term, but rather in order to indicate, in summary fashion, the existence of a range of disparate social forms, all of which are based on putative patrilineal descent, are relatively large in scale, and may or may not be exogamous.

The reason this analysis is starting from a vague and inadequate anthropological category, rather than an indigenous category, is that large groups based on putative descent seem to have participated in varieties of political action which were different in kind from the actions of groups based on actual descent (called lineages below), and there is no indigenous category which makes the distinction

between the two kinds of groups. The trouble may be that descriptions of political behaviour which took place two hundred years ago have survived, while the terminological distinctions proper to that period cannot be ascertained.

There are several words, used today, which refer to relatively large scale descent groups. Mbai (singular and plural), or mbali, means variety, kind, sort. One can speak of the Peugeot as an mbai of car, a kind of car. The word is also used at times to mean what we think of as an ethnic group, as when one speaks of the mbai of the Pare. The word is used to refer to groups based on putative descent, as well as relatively large groups based on real descent. Kolwa (pl. makolwa) also denotes a large scale descent group. It is most frequently (but not always) used to refer to one of several groups in opposition, and is therefore most appropriate for referring to sub-groups of any larger group. Tambi, which means branch (pl. matambi), is also used to denote sub-groups of a descent group.

Clanship is not at all uniform or evenly distributed over Shambaai. Indeed, one of the advantages of collecting historical traditions over all of Shambaai is that one begins to understand the impossibility of making any simple statement about the characteristics or distribution of Shambaa clans. There are large areas of Shambaai where lineages are not joined together in larger groups based on putative descent. This is true of much of southern Shambaai, and especially of Vugha. Variations in the distribution of clanship over

space help to explain discrepancies between the reports of ethnographers. Wohlrab, who lived at Mlalo, reported that the Shambaa had unions or leagues of lineages, which had special relationships to totemic creatures (1918: 164), while his colleague LangHeinrich reported from Vugha that there were no groups which took plant or animal names (1903: 220). Observers at Mlalo and Vugha would contradict one another in the same way today.

The variations in space are related to variations in time. In order to understand this relationship it is necessary to trace the development of two of the most important Shambaa clans: the Hea and the Nango. According to the historical traditions, the Hea were among the earliest inhabitants of southern Shambaa. The apical ancestor came from Zigula, lived in Vugha, then moved from Vugha to Ubii, and was living in Ubii when Mbegha, the first King, arrived. It is clear that no one man could have lived long enough to do all the deeds of the Hea apical ancestor (Mhina), but the logic of clan-ship is such that the Hea need only one such ancestor, since segmentation is said to have begun only after he had died.

My Hea informants said that the clan had a "great house" at Ubii, in which objects were kept for rites which the leader made for all Hea. The leader had magical charms for the defense of the land of Ubii, and for its fertility. Leadership, and possession of the charms, were inherited by the son of the leader's senior wife. The leader had an important role in sacrificial rites and in rites of passage (all

this according to the traditions). The Hea had a prohibition against eating the flesh of the bushbuck, and they formed an exogamous group in the period before the founding of the kingdom.

According to the Hea traditions, "Mbegha [the first King] looked around to see who the strong people were;" he saw that Mhina, the leader of the Hea, was one of them, and plotted to have Mhina murdered, and then to have Mhina's successor (Shemdola) murdered. After this, according to the traditions, the Hea split up. Some fled to a place named Mpangai where, when enduring a siege, they are said to have given up their prohibition on eating bushbuck. The other main group stayed at Ubii. It is said that with the fragmentation of the Hea the rule of exogamy ended, and it became possible for Hea to marry Hea of other lineages. After some time passed, several Hea became important appointed officials at the royal court.

Today there are lineages all over Shambaai which call themselves Hea, which remember versions of the tradition given above, and which distinguish themselves as Hea of Ubii, or Hea of Mpangai. There are no special Hea rites, nor is there a ritual leader. Each Hea lineage has a separate genealogy which goes back three generations from the oldest living member, to which are added the name of Mhina, and sometimes Mhina's successor. The lineages are juxtaposed in a linear series within each of the two sub-groups (Mpangai and Ubii). There is no order of genealogical segmentation associated with the division between Ubii and Mpangai; the division is by place alone. No claim

is made that all Hea are descended from the leader who was killed by Mbegha. It is contended that all Hea are descended from the apical ancestor who left Zigula to go to Shambaai. When he is remembered he is simply given the same name as the leader killed by Mbegha.

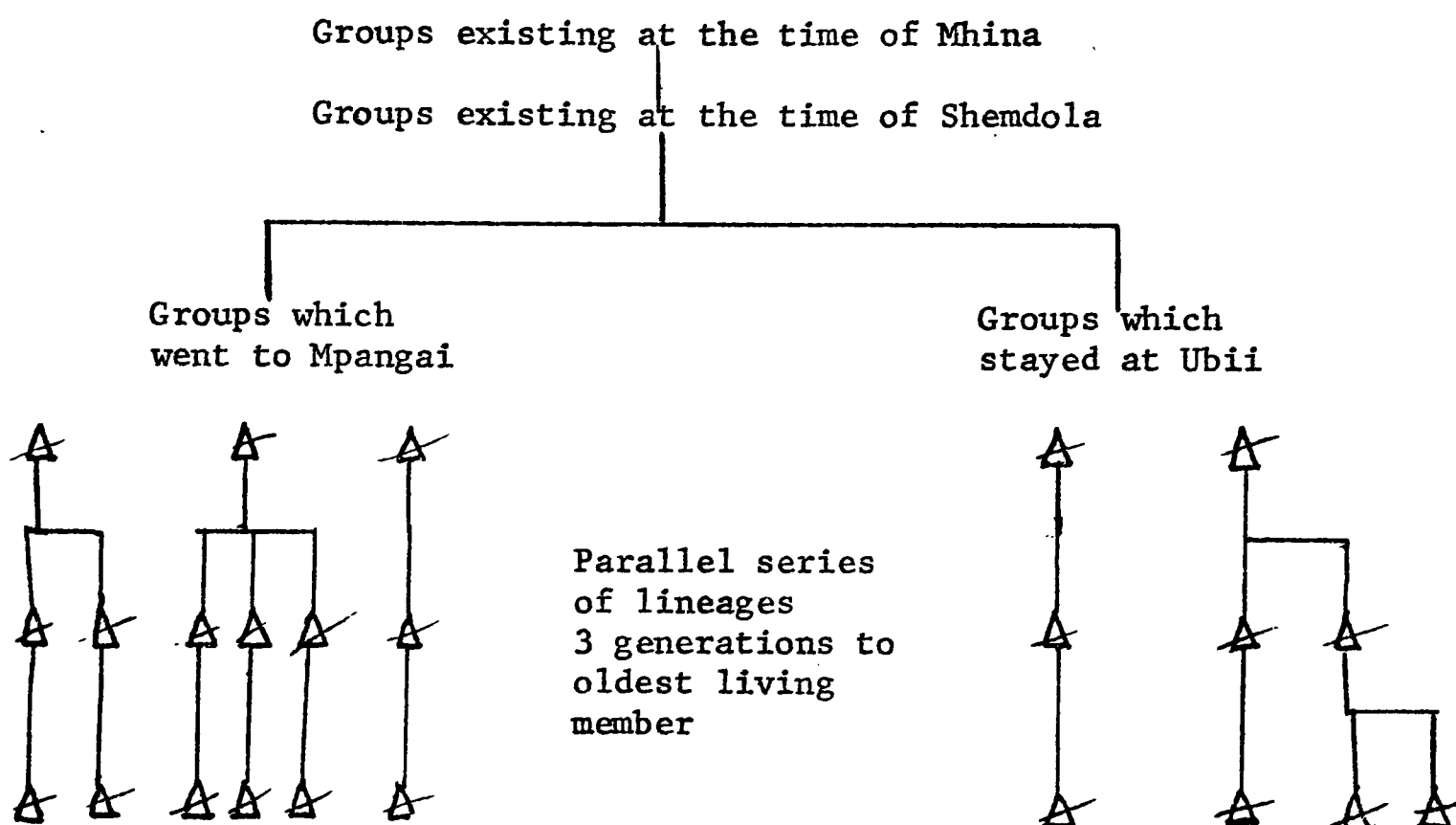

Fig. 2 Schematic Representation of Hea Clanship

Let us turn now to an examination of the Nango clan, which is unique among Shambaa clans in its division into six sub-clans (based on putative descent), each with a ritual function. This description, taken with that of the Hea, will show just how difficult it is to generalize about the nature of Shambaa clanship, and it will give further evidence on the importance of clanship in the politics of the kingdom in the eighteenth century, the time of the first three generations of Kings.

Nango informants describe how the Nango originally came to Shambaai from Pare, to the west, under the leadership of Saguruma, who was succeeded by his son Mbogho. Some informants say that the six Nango sub-clans all entered Shambaai with Saguruma; others say that each sub-clan is formed by the descendants of one of Mbogho's six sons. All Nango agree that the entire clan shares agnatic descent. Before the founding of the kingdom, the Nango dispersed to all parts of Shambaai. Mbogho, the ritual leader, lived in Shume, on the western edge of Shambaai. Periodically, all the Nango met at Shume to hold an enormous rite of passage, called mshitu, for all the young men. Each of the six sub-clans was named after a living thing. Each name begins with the word wavina, 'the people who dance,' and then the name of the creature is given. Thus the sub-clan of the ritual leader was the Wavina Mpaa, 'the dancers of the dwarf antelope.\* Each

---

\*The other sub-clans are named after the mpuku and the shange, two rat-like animals, mada -- lice, nkima -- a kind of monkey, and nkaa -- a crab.

sub-clan had a rite in which the named creature was an important symbolic object. These rites no longer exist, and so it is difficult to say anything reliable about them. There was no prohibition against the eating of the sub-clan emblem, except in cases where (as with the nkima monkey), the emblem was normally considered inedible by the Shambaa. Each sub-clan was exogamous, and in addition Wavina Mpa and Wavina Mpuku were not allowed to intermarry (allegedly because one such marriage long ago led to violence between the two groups).

During the reign of Bughe, the second King, the ritual leader of the Nango (Mbogho) attempted to increase his power at the expense of the other sub-clans, according to Nango traditions. In a dispute, the details of which Nango informants regard as still politically sensitive, and which they hesitate to describe, Mbogho killed a member of the Wavina Nkima. Some members of the Wavina Nkima then went to Vugha to offer their services to King Bughe as assassins. After they killed Mbogho, five of the sub-clans were persecuted by Bughe, who is said to have hunted out and killed Nango. Many localized Nango groups split up, their members fleeing to live with non-Nango affines, or in inaccessible villages. But the Wavina Nkima supplied one of Bughe's most important wives. In the succession war which followed Bughe's death, the Wavina Nkima fought successfully to make their woman's son King (Feierman 1970). This is the origin of the Nango claim that they are mother's brothers to the King.

Among the Nango, sub-clan exogamy has only recently begun to break down. There are no more sub-clan rites, and mshitu is no longer practiced. The Nango have the same lineage structure as all other Shambaa, with each lineage based on a genealogy which extends three or four generations before the oldest living member. The lineages of a sub-clan do not merge in segments, but are juxtaposed in linear series, much like the Hea.

An assessment of the place of clans in Shambaa society must be based on judgments which are either simple and uninteresting, or difficult and questionable. Clans and sub-clans today are social categories with few functions. They enable men travelling in strange villages to greet one another with somewhat greater warmth than they would strangers who were non-clansmen. It is clear, however, that clans carried important functional loads in the domain of politics in the eighteenth century, although the precise forms of political action cannot be determined in any systematic way. Clanship and chiefship provided alternative ways of organizing action on a scale larger than that of the lineage or the village, and alternative ways of mobilizing support. The competition between leaders (and between institutions) was partially resolved when the early kings defeated the Hea and the Nango, and brought about the death of the clan leaders.

The historical interpretation presented here makes it possible to understand two sets of facts which would otherwise be anomalous. First, it is apparent from even a superficial and sketchy comparison

of the Hea and the Nango (and made even clearer by an examination of additional clans) that there is little uniformity of clan organization in Shambaai. The variety of clan organization is easy to understand if we do not project the existence of a homogeneous Shambaa people back into the eighteenth century. When it became clear, with the death of the Hea and Nango leaders, that clanship was not going to be the basis of later political organization, there was little incentive among clan members and leaders to modify clan structures. There was no hope of meeting new political challenges. The heterogeneity of clan structures is related to a lack of structural change, which is itself a result of a perception that clanship had no special political utility.

The second set of facts which the description here makes understandable is that there are large areas of Shambaai in which there are no clans, and in most areas lineages which are integrated into clans are interspersed with lineages which are not part of clans. The absence of clanship in many areas seems to be a result of the active policy of the early Kings, who attacked clan leaders as potential competitors. Vugha, the chiefdom in which the Kilindi were most influential, was the chiefdom in which clanship was most completely suppressed. There are Nango in Vugha who use the term Nango without knowing that it refers to a clan, and without knowing the history of Mbogho. Nango for them is simply a term of origin for the identification of countrymen (see below). The Nango of Vugha claim to have no

known agnates beyond the limits of the lineage. One Nango friend of mine at Vugha, a man in his fifties, intimated that his grandfather had known more about Nango origins but had instructed his father never to speak of the subject for fear of enraging the King which, he believed, would have led to the destruction of the lineage. This was probably an extreme case. In other areas clanship may have withered away, as individuals in small clans moved away from clan centres to find new land. This last suggestion, however, is purely hypothetical, and is not a subject for serious consideration.

Members of every lineage which is not integrated into a clan remember the name of their place of origin outside Shambaai. Thus there are dozens of lineages in southern Shambaai which call themselves Zighua. They originated in Zigula, to the south. These lineages which share a single name make no claims of common descent. Zigula is a large land, and any two lineages may well have originated at opposite ends of it. The closest parallel to these origin names in my own experience is in the American Jewish conception of Landsmann -- a term applied to anyone who came to the United States (or whose parent or grandparent came to the United States) with whom one shares a common village or region of origin in Eastern Europe. Landsmann means 'countryman,' with the implication that two Landsleit are not kinsmen. One would not usually call a kinsman by this less intimate term.

## II

In comparison with the great diversity of clan forms, there is relative uniformity in lineage forms. During the past hundred years, there has been variation over time in the functions of lineages, but the variations seem to have occurred in much the same way over most of Shambaai. (The changes will be examined below, after the description of maximal, medial, and minimal lineages.)\*

The maximal lineage is of shallow genealogical depth, normally extending back three generations from the oldest living member to the founding ancestor. The mature members of a maximal lineage know the precise genealogical ties through which they are related to one another.

A typical maximal lineage has members spread through several villages within a chiefdom, with some members perhaps in a neighbouring chiefdom. Shambaa villages usually include members of two or more lineages. Each lineage within a neighbourhood (and of course within a village) is linked to a number of others by multiple ties of affinity and of the blood pact. (See chapter iii). Members of the maximal lineage may never marry one another. The older men may

---

\*The present tense is used in the description of the lineage because the data which come most vividly to mind, during the writing, are the data of field observation. The historical accuracy of the description (for the period 1880-1910) has been checked carefully at every stage of the analysis. References to the written sources are scattered through the description, even where the analysis is based primarily on field observation. Variations over time are discussed in sections iv and v of this chapter.

contribute toward the bridewealth of one another's sons, although they are under no obligation to do so. (See below, on bridewealth and the changing political role of the lineage.)

The maximal lineage does not recognize the authority of any one leader, nor does it participate in continuous activities as a group. Activity by the group takes place only in certain contexts, although ideas about the group continuously influence the behaviour of individuals. The most important activities of the group as a whole are the mourning ceremonies (ndio, or ndilo, or kuhoza ndio) after the death of a man, at which the man's wife and children are inherited by a lineage member. The entire lineage supervises the inheritance, and ensures that the interests of the young children in wealth and farms are protected, and that women and children are not left without guardians. When they are not meeting together, however, the members are continuously influenced by the notion that all the members of the maximal lineage share the effects of certain kinds of misfortune caused by mystical forces. These ideas are expressed in concrete form in the part of the mourning ceremonies at which the cause of death is 'cooled.'

In the remainder of this section I shall explore the characteristics of the maximal lineage by examining first, the way in which widows are inherited, and then ideas on the causes of death, and on their expected effects among the living members of the lineage. After that will come a brief discussion of the sacrificial medicine basket,

which is the concrete representation of lineage unity, and of the way in which the basket is divided at the time of lineage fission.

At the death of any adult, all the members of the maximal lineage are called together. Any branch which is not invited to these ceremonies can reasonably take its exclusion to mean that those in charge wish to split the maximal lineage. An invited member who does not attend is sent meat so that he can partake of the communion.<sup>1</sup>

There are three categories of property which may be inherited. Ntanu (plural only) are personal effects which are intimately associated with their owner's personality. Clothes, and bows and arrows are ntanu. Mai or mali (plural only) means wealth, taken as 'a collective term for those things the abundant possession of which constitutes riches' (S.O.E.D.). Mai is a loanword from Swahili (LangHeinrich 1921). It is probable that before this term became current, ughoi was used to mean the same thing (Steere 1867: 19). Mai includes livestock, money, cloth in sufficient quantities to be treated as a trade good, ivory -- anything which is normally sold for money or livestock. Maghisa (s. ghisa) are gardens, the third category of property.

Of the three categories, only ntanu (personal effects) must be transferred during the mourning ceremonies. A man's gardens begin to be allocated to matricentral houses when he marries, and he begins to transfer wealth when his sons marry. The inheritance of wealth and gardens is therefore best treated in the analysis of domestic

groups (chapter iii). Those meeting for the mourning ceremonies consider problems of wealth and gardens only if the dead man has left minors, or if there is considerable disagreement among the heirs. In the easy cases, these two categories of property are omitted from consideration. In contrast with these, personal effects, together with widows, are subjects of discussion at the ceremonies. While wealth and gardens, it will be seen, are transferred from one generation to the next -- from a man (or a woman) to his sons -- personal effects and widows are kept within a single generation: they may be inherited by any member of the maximal lineage within the dead person's generation.

The choice of the heir is made only after the widow's close relatives in her natal lineage have agreed that she may be inherited. The widow's lineage may withhold consent until outstanding bride-wealth is paid. Members of the dead man's maximal lineage then choose the names of three men of the appropriate generation. The names are sent in to the widow, who waits in her house. If the widow wishes to be inherited by one of the three, she indicates her choice. Otherwise, she sends the mediator (mtani, pl. watani, literally the trickster, or the person with whom one has a joking relationship) for more names.

If there are no more members of the generation of the deceased, the widow may be inherited by someone of the second descending generation. I learned of a number of cases in which this had, in fact,

happened. There are very rare occasions on which a man of the second descending generation inherits the widow of a man whose generation companions are still alive. This occurs when there are great disparities of age within a generation, and the widow is closer in age to the members of the second descending generation than she is to her husband's generation companions.

The extent to which the heir becomes involved in the supervision of the dead man's wealth and gardens, and in the home life of his new wife and children, depends on the ages of the widow and her children. The widow herself chooses an heir appropriate to her circumstances. If she has young children, she chooses an heir who is sympathetic and lives near to her house. If she has adult children, she chooses someone unlikely to involve himself in her affairs.

In one set of mourning ceremonies that I attended, in the village I lived in at Mshihwi, the dead man had two brothers, one close to the deceased in age living in the same village, and a young man who lived about thirty miles away. The widow had a married son who lived in the same village. All the men of the village, and of the lineage, wanted the widow to choose the brother who lived in the village. The widow, however, did not want to be responsible to a new husband; she wanted to be cared for by her son, and to have an independent position in the village. She insisted, against the wishes of the young man, on being inherited by him. Census data which I collected in 1968 show that this woman was not at all atypical. The data on choice of heirs are very limited and inadequate, but they support the statements made above.

Place of Residence at Time of Census.  
Village of:

	a	b	c	d	e	f	
Heir		Widow's	Widow's	Husband	Deceased	Other	
		own	Patri-	(Heir	Husband	(Prostitute)	
		Child	lineage	Divorced)	(no move)		TOTAL

Widows with at least  
one married child at  
time of inheritance

0	6	1	1	5	0	13
---	---	---	---	---	---	----

Widows with no married  
children at time of  
inheritance

8	0	3	3	1	1	16
---	---	---	---	---	---	----

Fig. 3 Choice of Residence by Inherited Women, as Reported  
by Heirs

One effect of the mourning ceremonies, and widow inheritance, is to ensure that each reproductive unit will survive, and that there will be orderly transfer of property within it. The maximal lineage acts to ensure the survival of its smallest segments. In addition, the mourning ceremonies are crucial in defining the extent of the maximal lineage. Widow inheritance is directly (and consciously) tied to the rule of exogamy: a man may not take a wife from among the daughters or sisters of the men with whom he has mutual rights of widow inheritance. If the lineage has split (described below), a man may marry his own agnatic relation, even if the ties of relationship are clearly remembered. Thus the exclusion of a branch of a lineage from the mourning ceremonies is a double declaration: first, it is being declared that the uninvited branch has no right to inherit the wives of those present; second, that branch does have a right to marry the sisters of the men present.

It is useful to digress very briefly on the movement of the dead man's ghost in the mourning ceremonies and the sacrifice of the clinking bells (fika ya chekecheke), before going on with the study of the maximal lineage's sense of shared fate at the time of widow inheritance. In the mourning ceremonies, a goat is sacrificed at the door of the widow's house after she has been inherited. This action is crucial in removing the ghost of the dead man from among the living, and establishing him in a limbo between the living and the ghost world. Several years later, at a time when a child is sick, or a cow has

died, a diviner informs one of the sons of the dead man that the sacrifice of the clinking bells must be made to his father. There is a sacrificial rite which lasts all night, at which all the sons of the dead man are present, and a medicine man from another lineage is present, together with one of the oldest men of the maximal lineage of the generation of the deceased. The old man invokes the dead father, and then the more distant lineage ghosts who have been dead for longer periods. The brothers do the same. Then the medicine man invokes his ancestors. Finally the sacrifice itself provides a feast for all the spirits together, integrating the dead father into the world of the ghosts, and making him less dangerous. Here, as in widow inheritance, the maximal lineage (in this case through the participation of the senior elder) performs services essential for the preservation of its smaller segments.

\* \* \* \*

The major ideas on the sharing of mystical fate within the lineage are given concrete expression in the mourning ceremonies, in the actions taken to protect the living from the dangers which have just taken a member from among them. It is not my intention here to give a full description and analysis of the symbolic actions in the mourning ceremonies. The ceremonies deserve a treatment far longer than can be provided in this context. But it is impossible to understand the characteristics of the maximal lineage without some consideration of the various causes of death, and the response of the lineage to each.

The men of a lineage decide on the cause of the death of a member after sending messengers to hear the opinions of a number of diviners. The men are naturally concerned to arrive at a cause of death which will cause the least division among them. It is very grave when a branch of the lineage remains uninvited, for this may mean that it is suspected of sorcery in the case. The entire maximal lineage participates in the action 'to cool' (-hoza) the cause of death, which may continue to affect the living, causing further deaths.

There are five categories of possible causes of death, as seen by the Shambaa: harmful medicines, pollution, taking one's own life, natural causes, and the failure of defensive medicines. Each will be discussed briefly in turn. My intention is to mention the effects of each on the survivors, and the importance of each for the sense that lineage members have a shared fate. There is no space here for a complete study of conceptions on the causes of death.

Medicines or charms (ughanga) can be used for protection, for attack, or for cures. Usually the medicines which are employed in attack, are essentially the same as those which cure the resulting condition, with perhaps one ingredient changed, and with a slight revision of the spoken spells. The category 'harmful medicines' is being used, rather than 'sorcery' (ushai), as one of the five categories, because there are protective charms which are thought to kill, and which are not sorcery because their use is seen as legitimate. Whether

their use is legitimate or not, whether the charms used are seen as protective charms (makagho, s. kagho), or as attack charms (ushai), their effect on the survivors is the same. The medicine which caused the death is potentially harmful to the living only so long as it is not 'cooled,' and so long as the personal effects being inherited are not 'cooled.' The inheritor of a widow, and with her of personal effects, is always the individual in the greatest danger. It is thought possible for a chain of deaths to occur within the maximal lineage as a result of the inheritance and re-inheritance of personal effects which have not been properly cooled. If proper counter-measures are taken, however, no further harm is caused. A person who has been killed by dangerous medicines may be buried in his own banana garden without any danger for the living.

The nature of death as a result of legitimate harmful medicines, and of the cooling process, will become clearer if I describe a set of mourning ceremonies I observed at Mshihwi, in October of 1966. A man whom I shall call K developed a severe case of diarrhoea, which continued for about two weeks, until he died. It was common knowledge among the people of the village that K had been sleeping with the divorced former wife of M. K, and M, and M's former wife, all lived in the same village. After M and his wife had been divorced, M had announced that he did not care if she remarried, so long as it was not to someone in the same village. When K began to sleep with M's former wife, M (who was the best known medicine man in the area)

became angry, and it was believed that M placed an ushinga charm in his former wife's path. Ushinga does no harm to the woman in whose path it is placed, but it is believed that any man who sleeps with her will die of severe diarrhoea.

There was no problem determining the cause of death, given the general agreement among members of the community. But the charm itself had to be cooled. The members of K's lineage therefore engaged, as their diviner and medicine man, a lineal kinsman of M. The medicine man went to M's house with a small group of men, he said that everyone knew K's death had been caused by ushinga, and he asked M for the charm which had been used. M went into his house for a moment, and returned with the charm, so that the medicine man could treat it with cooling medicines.

The second stage in the cooling process came with the transfer of personal effects. These went to the widow inheritor. In the death of a woman they would go to a woman of the natal lineage of the deceased in the same generation. The key actor in the transfer was the mtani, the joking partner or mediator, who could not be a person belonging to the lineage of the deceased, or to any lineage which was affected by the death. In this case the joking partner was a prominent medicine man who lived about four miles away. He touched each object with cooling medicines, and then used it as though it were his own: he tried on a jacket, put a knife in his own sheath. He then passed the objects on to the heir. The transfer of the clothes is related to

the transfer of authority over children. One man explained: 'At night, when I dream, my father is still wearing the clothes which his heir now wears.'

The second category of causes of death is pollution, meaning a condition in which fundamental category distinctions by which the Shambaa order their world are violated. An example will make this clear. Infants born in a way not thought proper for human beings are called vigego (s. kigego), and are capable of causing death to members of the maximal lineage. Twins are vigego; infants which cut their molars before their front teeth, or their upper teeth before their lower are vigego. Breech births are vigego. One informant (whose views on this are representative) explained the relationship between violation of categories and danger; he said: 'An infant's molars appear first. He is a kigego. He has been transformed. He is not of the same species that we are. A beast teethes in no particular order, but not a human. Perhaps we will sicken because of him. We will become sick from fear. The ancestor spirits do not like vigego. Goats have twins, but people do not. He is like an animal.'

Most vigego were killed in the pre-colonial period. Some still are; others are sent to a Christian orphanage at Irente, in Shambaai. Even in the pre-colonial period, a number of vigego were allowed to survive. But if someone in the lineage died, and if the diviners

reported that the death was caused by a kigego, then the offending survivor was either killed or driven out.\*

Other conditions of pollution include leprosy (ukoma), smallpox (ndui), and unhealing open sores of any sort. Conditions of pollution are, in most cases, thought to have no particular moral cause -- they simply happen. Pollution is dangerous to all members of the maximal lineage, and is considered as likely to harm any one member as it is to harm any other.

In death which results from a condition of pollution, the personal effects are not inherited, but simply left in the wilderness. The body is not buried; it is left in the wilderness in a thicket, or a rock hollow. When the men return from 'throwing away' (-asha) the body and the personal effects, they kill a goat on the path, and spread cooling medicines, 'in order to remove the footprints' and erase any connection with the polluted objects, and the polluted body.

The third category of causes of death is the failure of moral will which results in a person taking his own life. The many forms

---

\*W. Hosbach, one of the early Lutheran missionaries, reported (1925: 8-9) the life story of a pre-colonial kigego -- a woman who as infant had cut her upper teeth first. She survived because her mother had threatened to kill herself if the child was killed. Hosbach does not mention it, but I would presume she threatened to break a cooking pot and take the entire lineage with her, by hiding the pieces. The kigego grew up, married, and had a son who became a leper. She was killed in the end by a cousin who had a wound which would not heal, and who had been told that it was a result of the kigego's presence in the lineage. The precise details of the relationship between the kigego and her cousin were not given by Hosbach.

of suicide are called kufa viwiwi -- 'to die badly.' Included in this category are death by hanging oneself, women's death because of the breaking of a cooking pot (described below), death as a result of violation of the blood pact,\* and death as a result of violation of an oath. Swelling of the body, and especially of the stomach, is said to be characteristic of 'bad deaths.'<sup>2</sup>

Suicides are said to result from a weakness or disturbance of the heart (moyo, pl. myoyo), which is the locus of thought, and of the moral will.\*\* But even in mystical suicide, the will to die, without appropriate action, is not enough to cause death. A person dies as a result of pronouncing an oath, and performing the appropriate physical action.

In death by the cooking pot, for example, a woman who wishes to die breaks an earthen cooking pot, takes two fragments, rubs them together over a vessel of water, and says, 'Oh cooking pot, I wish to die.' She may explain her reasons, and she may specify the people she wishes to follow her in death. She then hides the shards. Some time later she dies. The oath by itself cannot cause death. Breaking a cooking pot and drinking water with fragments have no harmful effects

---

\*The blood pact is described in chapter iii.

\*\*Two young school girls explained to me that 'the heart is for thinking, and the brain is for education' (elimu).

without the oath. The reason a cooking pot is used was explained to me in the following way: 'When a woman is making a cooking pot, she bakes it. The clay becomes black all the way through. It has been transformed (-hitulwa). The clay has been transformed into a pot. Things which were red have become black. . . The woman sends the pot to transform her own body. She is saying, "As I transformed you, so you will transform me."' Pregnant women are thought particularly likely to commit cooking pot suicide, for 'when two hearts beat inside one body, all stability of moral judgment is lost.' And of course pregnant women die with swollen bodies.

In discussing the effects of this kind of death on the living, it is necessary to distinguish the special effects of cooking pot suicide from the more general effects of 'dying badly.' In cooking pot suicide the woman specifies those she wishes to follow her. This does not remove other members of her natal lineage from danger, but it makes certain that unless proper counter-measures are taken, those specified will die. These are most frequently her sons and her brothers. The members of the woman's natal patrilineage act to avert the effects of her oath. If the woman was pregnant, the fetus must be removed from her body. The shards of the broken cooking pot must be found and cooled.

In addition, cooking pot suicide has the effects shared by all 'bad deaths.' As in the case of pollution deaths, anyone who inherits the personal effects is believed to be in danger, and so these goods

are left with the body in the wilderness, and the path leading back to the village is cooled. In spite of all precautions, however, bad deaths may lead to further deaths among members of the maximal lineage. There is no way to control or limit the danger, and no way to predict where within the descent group it will strike. A case was mentioned above, of death as a result of ushinga -- the harmful medicine which killed the man who slept with the former wife of a medicine man (p. ). Several weeks after the ushinga death, two of the medicine man's children by his former wife died. Everyone agreed that these deaths could not have been caused by the earlier ushinga, since ushinga, once cooled, has no further effects. These deaths were attributed to a broken oath in the medicine man's lineage, which was thought to have caused one earlier death.

Suicide is typically the last resort of an individual who is in a weak position within the descent group, and who feels that he is being treated unfairly, but is powerless to change his circumstances. Suicide by hanging was typically the act of a young man with a domineering father. It seems to be growing less frequent with the increase in options open to sons (see chapter iii). Cooking pot suicide is the action of a woman whose husband treats her poorly, and whose agnates do not come to her defence. Thus it is in the interests of the entire maximal lineage to restrain an unfair father, and to defend a married sister who is treated poorly, for if a suicide occurs, it will be only the first in a chain of deaths within the maximal lineage.

Death by natural causes -- utamu wa muungu, literally 'an illness caused by God,' is thought very rare. Diseases which result from natural causes are characterized as slow, wasting diseases, with symptoms which gradually evolve, as opposed to the dramatic changes of condition in diseases caused by man. Death is, by definition, a dramatic change of condition.

Most violent deaths, as in the case of deaths in war, are seen as results of the failure of defensive charms, usually because of the violation of a ritual prohibition (see chapter vii). Deaths by natural causes, and violent deaths, are said to have no special effects on the living. The individual may be buried in the banana garden, and his personal effects are cooled and inherited.

\* \* \* \* \*

It is possible for any maximal lineage to split into two lineages which are seen as unrelated with regard to exogamy, widow inheritance, sacrifice, and the sense of shared vulnerability to the mystical causes of death. The boundaries of a maximal lineage can never become blurred, for the basket of ritual objects used in sacrifice is a precise indicator. There is one such basket, which is used in the sacrifice of the clinking bells, for one maximal lineage.

The basket, or pouch, is usually of the kind called mfuko (pl. mifuko), a relatively small basket with an oblong opening. It often has a basketry cover. This sort of basket is used by men for keeping medicine gourds and charms. Food baskets used by women have

rounded openings, and a different name (n-tezu). Basket making is men's work. The objects kept inside are among the few Shambaa magical charms over which no spell is uttered. There are oyster nuts (nkungu, Telfaria pedata), two medicine gourds holding the ashes of the mvuti and of previous baskets mixed with honey (see p.294 for a discussion of the mvuti), and a wooden spoon with a bowl at either end. The oyster nuts and mvuti pegs are among the most important objects used in the sacrifice of the clinking bells, and the sacrifice itself is seen as the equivalent of a spoken spell. In cases of illness which are attributed by a diviner to an ancestral ghost, the keeper of the basket invokes the ghosts while spilling some beer or water on the ground, he chews an oyster nut and then rubs it onto the skin of the afflicted person, and then he gives some of the medicine from the gourds for the person to taste, using the left bowl of the spoon if the person is female, and the right if male.

When fission takes place within a lineage, the basket is divided: a small piece of the old basket is woven into a new one. The remainder of the basket and its contents are burned and placed in the new gourds. At times when the maximal lineage is not engaged in any activities, the basket serves as a concrete representation of its continuity and discreteness. The Shambaa say that if two men share the use of a sacrificial basket, they must call one another to mourning ceremonies, and they may not marry one another's daughters. The use of sacrificial baskets as indicators of lineage identity is

beginning to be modified as a result of conversions to Islam and Christianity, although most lineages still have some members who practice sacrifice.

Lineage fission takes place when one branch of a lineage lives too far from another for constant feasting and consultation, for use of a common sacrifice basket, and for easy attendance of mourning ceremonies. Lineages do split when they become too large, or when there are serious disagreements between branches, but Shambaa informants say that lineage fission can only come after, and as a result of, spatial separation.

The course of lineage fission is illustrated by the history of a lineage which had branches in the chiefdom of Vugha, in the chiefdom of Bumbuli, and in the chiefdom of Ubi (now Lushoto Division). In the 1880's the original lineage was in the chiefdom of Bumbuli, but a war was going on, and a skilled warrior could make his fortune at the royal capital of Vugha. Several men of the lineage moved to Vugha. The move was not preceded by any serious disagreements, and so the men at Vugha and the men at Bumbuli remained members of a single maximal lineage, although they drifted apart. The son of one of the emigrants, now an old man named S, inherited a wife at Bumbuli when he was much younger. But the members of the lineage at Vugha say that there are too many young people they do not know at Bumbuli, that the lineage has split off, and that the young men of Vugha could, if they wanted to, take wives at Bumbuli, although it is unlikely that they would do so.

Of the men who had moved to Vugha, some moved on to other chiefdoms, one moved to Pare, and some did not have sons. There were two men, however, who had large numbers of children and grandchildren -- Sk and Ki. Of Ki's sons, the most prominent now at Vugha, living near the heart of the chiefdom, is the old man S (mentioned in the preceding paragraph) who has large numbers of children, grandchildren, and great-grandchildren. The descendants of Ki's other sons at Vugha respect the word of S. Sk's most important son was B, who is now dead. His agnatic descendants are divided between the village of Vughii, a few miles from the center of the chiefdom of Vugha, and at Lushoto, about fifteen miles away. The only survivor from among Sk's sons is ML, who is a very old man living half way between Vughii and the center of Vugha.

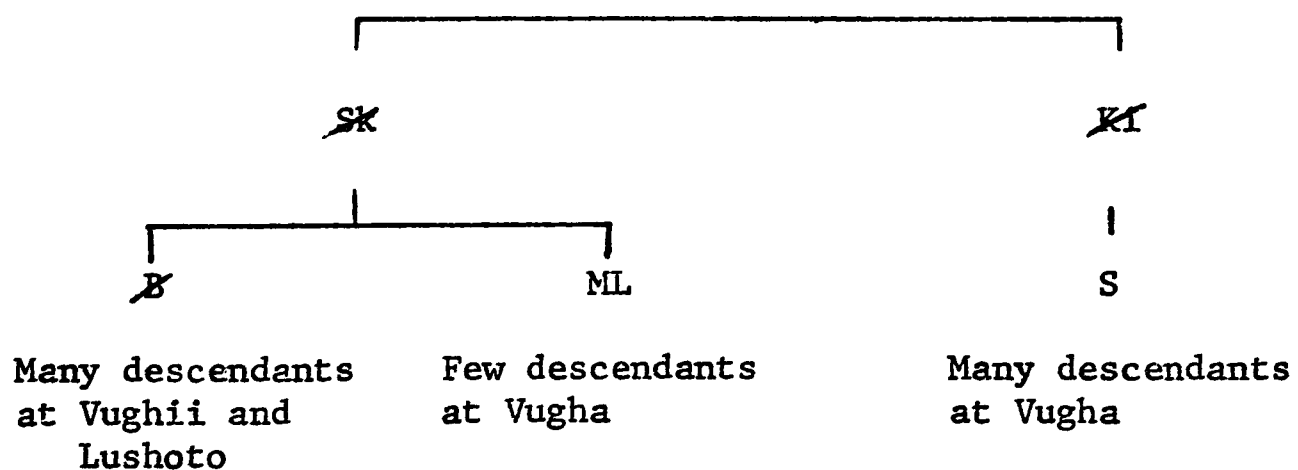

Fig. 4 Schematic Representation of the Lineage of Sk and Ki.  $\beta$  = B deceased.

For a number of years, tensions have been developing between the agnatic descendants of B and those of S. One contributing factor is certainly S's survival. ML is extremely old and blind and rarely leaves his house. The sons of B, free of his interference, think of themselves as the eldest generation in their lineage, now that their father is dead, and yet S takes an active interest in their affairs. A few years before I knew them, the sons of B at Vughii engaged in open hostilities with the sons of S, a few miles away. There were accusations of sorcery on both sides, until S brought them all together, and made them swear oaths that if they ensorcelled one another they would die.

Then, about a year after the oath, there was a death at Lushoto. The sons of B at Vughii were called to the mourning ceremonies, but S and his sons were not called. Yet the sons of B at Vughii recently invited the sons of S to a wedding. Quite clearly the sons of B would already have split off from the sons of S were it not for the proximity of Vughii and Vugha. ML also seems to have a moderating influence. The sons of S seem to feel that their group is quite large enough to be a lineage on its own, but they support S in his claims of authority over the sons of B. The long term outcome is clear. When S and ML die, the maximal lineage will split to form two separate maximal lineages: the descendants of Sk, most of whom are sons and grandsons of B; and the descendants of Ki, most of whom are sons and grandsons of S.

This illustration helps to explain one of the most difficult features of Shambaa descent structure. Maximal lineages are genealogically shallow, with no great internal segmentation. It will be shown in chapter however, that most of the sons of any one man tend to live near their father. They do not move far even once he has died. Generally, only a few sons of any large family move away to different chiefdoms. It is difficult to reconcile the spatial stability of Shambaa domestic groups with the shallowness of Shambaa lineages, in view of the fact that maximal lineages split only after spatial separation has occurred.

The solution results from the fact that there is an imperfect fit in the overlap of descent and residence. There is greater social distance between agnates who reside in a single chiefdom and have separate fathers, than there is between brothers who live in separate chiefdoms. When a group which has moved out of a chiefdom splits off from the maximal lineage, it takes with it close agnates who have never moved. In the example given here, the split between the sons of B and the sons of S, when it occurs, will have resulted from the spatial distance between Vugha and Lushoto. But the sons of B who live at Vughii, near Vugha, will become members of the Lushoto lineage, from which they are spatially separate, and they will break their ties with the sons of S near whom they live.

## III

Another way to describe the relationship between residence and lineage fission, is to say that a medial lineage -- even one which is territorially dispersed -- must remain united within a single maximal lineage. A medial lineage includes the agnatic descendants of the oldest living group of full or half brothers in a line of descent. The apical ancestor of the medial lineage is the father of those brothers. He may or may not be alive. In terms of the maximal lineage described above, S and his agnatic descendants form one medial lineage, the sons of B and their agnatic descendants form another, ML and his agnatic descendants form yet another. The genealogical depth of the medial lineage in any individual case depends on accidents of demography, and therefore the term refers to a range of lineage forms. The use of the term is justified, however, because there are certain ritual obligations and rights in property which are appropriate to the medial lineage.

While the father of the group of brothers is still alive, he has livestock which will ultimately be divided among them, and which are the units of social value to be used for his personal needs and to increase the number and well being of the dependents of each of his sons. The cattle and goats are used as bridewealth for the first wife of each son, as payments for important cures, as indemnities (in pre-colonial times) in cases of a breach of the law instead of pawning dependents (see p. 322f), and for rites of passage. The

importance of the medial lineage is related to the belief that after the death of the father, the livestock which are divided amongst his sons are in some senses still under his influence.

In terms of ritual behaviour and property rights, there are three stages in the development of that influence. At the time of the mourning ceremonies a goat is killed in a rite which is said to separate the dead man's ghost (mzimu, pl. wazimu) from the living, but not to integrate it into the world of the ancestral ghosts (kuzimu). During the period following the mourning ceremonies, the ghost is between the world of the living and the world of the dead, and is therefore thought to be dangerous. If a cow dies, or a young child becomes ill, and if a diviner decides that it is the action of the ghost, it is said that the old man is showing that he still has control over the things and people which are his. The only cure is the sacrifice of the clinking bells (fika ya chekecheke) which integrates him into the ghost world.\* Aside from the sons of the dead man, there are two important participants in the rite. There is the medicine man (mghanga, pl. waghanga) who must not be related, except perhaps as a distant affine, to the medial lineage making the sacrifice. And there is the representative of the maximal lineage, a man of the dead father's generation, who has come with the lineage's basket of ritual objects.

---

\*The author has witnessed a number of sacrificial rites, and intends to write a full study, for which there is not space here.

At the point in the rite when the ghosts are called up, the lineage elder takes a gourd with sugar cane wine, pours some of it on the mud floor of the house, and addresses the lineage ghosts, and then the new ghost, telling them all to sleep, to be peaceful. Then the medicine man addresses his own lineage ghosts and the new ghost in the same way. Finally the oldest of the dead man's sons invokes his father and the lineage ghosts. When the goat is killed, at dawn, and pieces of cooked meat and starch are placed near the threshold, it is said that the ghost being sacrificed to is given a meal together with the older lineage ghosts, and the non-lineage ghosts. The dead father will cause less trouble for the living now that he has been properly integrated into the ghost world. After the fika ya chekecheke has taken place, the ghost is less active, but must still be given deference. If a man goes to argue a particularly difficult case, he must pour some beer on the floor and say, 'Father, I am going to argue this case. May you sleep peacefully.' It is said that if this is not done, the case is sure to be lost. Ghosts communicate with the living through omens -- if you are going on an important trip, and a bird flies across your path from the left, for example, you know that the ghost is telling you not to go at that particular time.<sup>3</sup>

The stages in the development of the ghost's mystical influence are related, in an approximate way, to stages in the development of property relations. After the father's death, his wealth and gardens

are divided among his sons in a way which will be described in chapter iii . It is possible, however, to keep wealth and gardens which are not allocated to any particular son, and which remain the property of the entire medial lineage. Unallocated property is called kifu. Kifu gardens are much more rare than kifu livestock. The unallocated livestock are used for the sacrificial rite, for rites of passage of the young siblings or children of the controlling group of brothers, for first wives, for buying grain in famines, and for paying indemnities. The brothers use the unallocated livestock to make contributions to the survival and well being of the group in ways their father would use it for them if he were alive (except, of course, for its use in the sacrificial rite). If any brother insists on dividing the kifu, then it must be divided. Most commonly, unallocated wealth is kept by the medial lineage if the group of brothers holding it includes minors. In these cases, it is a way of saving the inheritance of the minors, and of keeping bridewealth for when they grow up. As the minors mature, and after the sacrificial rite, there is a stronger and stronger tendency for centrifugal forces within the medial lineage to bring about the division of kifu. There is a much greater tendency today for all wealth to be allocated than there was in the pre-colonial period (see p. 98 ).

Even once all property has been allocated there remains a residual sense in which some of it belongs to the medial lineage as a group. This applies to gardens. The land which has been inherited may not

be sold unless all the sons of the dead father have given their permission. In practice this means that those brothers who remain near the paternal homestead get the use of all the land which has been inherited, although absentees retain residual rights which they can claim if they return to the area, or which they can sell to the resident brothers.

When the brothers who are at the head of the medial lineage grow old and die, unallocated property (including the residual rights in gardens) must be allocated to the descendants of one brother or another. It is possible to speak only of kifu cha tate -- the unallocated property of father; it is unthinkable in Shambaa to refer to kifu cha baba -- the unallocated wealth of grandfather. No group larger than the medial lineage holds property in common. Similarly, the need to defer to the wishes of a ghost ends when all the sons of the ghost have died. Then each son is a ghost, for whom sacrifice is made, and who leaves omens for his own children.

#### IV

The minimal lineage includes any one man and his children. It is the framework of the domestic group. I am using the artificial term here for father and children in order to separate out the descent core of the household. It will be seen that the father and his children had jural liabilities, as a group, which were not shared by

the mother, and which were distinct from the jural liabilities of the lineage at any higher level of segmentation.\*

The property which is acquired by a man through his own efforts may be disposed of in any way that man chooses. While kifu land may not be sold, a man who clears an area of forest or bush himself may sell it. After his death, the gardens and wealth become kifu, and there are limitations on use.

The minimal lineage as defined here does not form a neatly exclusive category. It can be seen that the medial lineage of S, described above, includes one man and his children. In order to understand the relationship between the minimal and medial lineages, it is necessary to turn to a major problem which has been ignored up to this point: the problem of indemnities. An examination of this problem will also lead to a series of insights on changes in lineage action in the politico-jural domain over the past eighty years.

In the late pre-colonial period, when an individual was guilty of a major breach of the law, he was required to pay an indemnity (maliho) consisting of a certain number of goats or cows, with the size of the indemnity proportional to the seriousness of the breach. Court procedures, and the use of indemnities, are discussed in chapter vii. Here, however, it is important to note that the individual responsible for the breach had a choice between paying the

---

\*For a similar usage, see Fortes 1945: 192.

indemnity, giving his children to the chief as pawns until the indemnity could be paid, or being enslaved, usually with his children. In cases of pawning or enslavement, the chief paid the indemnity for the offender's group. In homicide, there was sometimes a choice between paying the blood price or having the offender killed.<sup>4</sup>

The security of a man and his children, in case of the assessment of an indemnity, was directly dependent on the willingness of members of the medial and maximal lineages to contribute toward the payment of the indemnity. Except in cases of rebellion against a chief, in which the entire maximal lineage was prosecuted for an act seen as group conspiracy, the minimal lineage was the largest group which could be required by law to pay an indemnity. Using the medial lineage of S as an example, and imagining it as existing in the pre-colonial period, it is clear that if one of S's sons had committed a breach of law, only that son and his own children -- that is, only his minimal lineage -- could have been required to pay. All the agnatic descendants of S could have been treated as a minimal lineage only in cases where S himself was the lawbreaker. The group which could have been required to pay an indemnity is not referred to here as a family or domestic group (rather than a minimal lineage) because a man's wife could not normally be pawned or enslaved in payment for his violations.<sup>5</sup>

While the minimal lineage had the sole obligation to pay an indemnity, or give up pawns or slaves, the medial lineage was thought to have an unenforceable obligation to contribute to the indemnity

owed by any one of its segments. There were a number of factors which determined whether the medial lineage would contribute. If the apical ancestor of the medial lineage was still alive, it was expected that he would contribute toward his son's indemnity. If the members of the medial lineage held some unallocated wealth (kifu) in common, then at least a part of the wealth would probably be contributed.

Today, it is extremely rare to find a medial lineage which retains unallocated property. In the case of the medial lineage of S, most of the gardens have been allocated, even though the apical ancestor is still alive. In the late pre-colonial period, when the retention of unallocated wealth was the rule rather than the exception, there was a series of concomitants of its retention, all of which went along with an obligation to contribute toward indemnities. When wealth was held by the medial lineage, the brothers accepted the leadership of the oldest son of their father's senior wife. He had the most important voice in decisions on the disposition of the wealth, including decisions on whether to contribute toward an indemnity. The retention of unallocated wealth depended, to a certain extent, on the quality of his individual leadership. Since any brother could ask to have his own part of the kifu allocated, the fund would not continue to exist if the leader took decisions with which his brothers disagreed.

When the medial lineage kept kifu wealth, the brothers tended to contribute toward the bridewealth of one another's sons, and to receive bridewealth as a group. (Bridewealth is described in chapter iii.) This means that each man's calculations of likely gains and losses

through common bridewealth payment were considered in his decision of whether to support or oppose the continued existence of a fund of unallocated wealth. In the case of the lineage of the Tetei in Mshihwi, in the 1880's, one member (Mbea Vintu) had a large number of sons, and all his brothers had daughters. Mbea Vintu's brothers divided the wealth, and they all moved off to a village about five miles away, so that the one man's sons should not use up the wealth acquired for the daughters of the others.

Another indicator of solidarity -- one which could apply to the entire maximal lineage -- was whether the members of the lineage all met to consume a feast which consisted of some meat from the bride-wealth payments, and the sugar cane wine that accompanied it (Dahlgrün 1903: 220; LangHeinrich 1903: 224). This feast was a relatively unusual one, for it emphasized the exclusiveness of the lineage (either the medial or the maximal lineage according to the practice of individual groups). In virtually all other Shambaa lineage feasts and ceremonies, it was required that members of other lineages be invited. The bridewealth feast, however, was held in the banana garden of the host, hidden away so that passing neighbours would not join. One very old man, who remembered the days when the feast was customary, explained the reason for holding it. He said, 'If my child then kills someone, who will help me to pay the indemnity [if I have not held the feast]? If the members of my lineage have eaten at it, they will help me in time of need.'

Even when a medial lineage kept unallocated wealth, had an accepted leader, and paid and received bridewealth as a group, the brothers could refuse to pay an indemnity if they objected to the character of the lawbreaker. If he was the sort of fellow who was constantly in trouble, they would insist that he pay his own indemnity (LangHeinrich 1903: 222). It is still true today that the support one can expect from one's lineage is dependent upon one's own behaviour in the past. I knew one man who was about forty years old, and who was chronically ill, probably with tuberculosis. He could no longer support his wife and children, who had left him. In normal circumstances this man would have been supported by the members of his medial lineage. But when he had been healthy he had been an inveterate thief, and a constant source of embarrassment to his lineage. At the time that I knew him, he was living on sufferance in the household of his sister's husband, who happened to be an extremely generous man.

No matter how the boundaries between indemnity paying groups shifted, groups within a single maximal lineage could never pay indemnities to one another. A crime by one lineage member against another was a matter for the lineage elders and not for the state. The elders could insist, however, that the criminal be given in slavery by his father. The young man would no longer count as a member of the lineage. This was done not only in cases of intra-lineage crimes, but in cases where habitual violators, especially

adulterers, incurred repeated indemnities. Once the chief had accepted the slave, he was responsible for all future indemnities. This custom died slowly. I knew one man who had been handed over to the King during the 1940's.

There were a number of misfortunes, in addition to the incurring of an indemnity, in which the freedom and survival of individual members was dependent on the wealth and solidarity of the medial lineage. Individuals (including women and children) who were taken captive in war counted as the slaves of their captors, but they could be ransomed if their lineages could get together enough livestock. Wealth was also essential for survival in times of famine. During the period between 1875 and 1900, for which continuous records exist, there were four famines: in 1877, 1884, 1894, and 1899. Many people died of hunger during a famine, and many of disease afterwards. A minimal or medial lineage with a great deal of livestock could sell some for cereals if neighbouring peoples had better harvests, or if imported food was available at the coast. Others were forced to pawn their children to the chief, who fed them; afterwards, they could be bought out of pawnship: an individual was redeemed with a payment of three goats. Poor groups were forced to leave their dependents in pawnship. Members of a large medial lineage could, through cooperative effort, free one member after another.<sup>6</sup>

In all of the misfortunes listed so far, it was the lineage's ability to mobilize wealth (mai) which enabled its members to survive,

and to retain their freedom. The association of wealth with the functions of the patrilineage is related to the notion that the pursuit of wealth, as opposed to the daily cultivation of plants for food, was (and is) strictly man's work. Men acquired wealth as a reward for distinction in warfare, by selling clarified butter or tobacco at the coast, by selling game meat, raising livestock, and as payment for the practice of medicine, or for work as smiths.

Outside the court, there were only a few limited uses for wealth in the pre-colonial period: for the purchase of food in time of famine, to pay a medicine man in case of a serious illness, for bridewealth, for rituals of passage and sacrifice, for the purchase of gardens, for the payment of an indemnity, and for the payment of tribute. If we exclude the last of these uses, which will be examined in detail in a later chapter, all the uses of wealth are directly connected to the preservation or procreation of life -- to the maintenance of living individuals within a descent group. In short, to social reproduction. Transactions involving wealth are seen as part of a zero sum game, especially in the less cash-crop oriented parts of Shambaai. One man explained to me: 'You do not simply come across wealth. It is like blood. If you have no wealth you are unable to do anything at all. If you have no blood you are unable to do anything. It is blood which does things. If you have no wealth you can die.' Ethnographer: 'Why is that?' Informant: 'Medicine men demand wealth. There is a proverb: "Many are the lives lost for lack of wealth (Vimba vingi ni vya ushoi)."'

In addition to its importance in providing its members with access to a common fund of wealth for times of misfortune, the medial lineage was a fighting unit, which increased the wealth and security of each of its minimal segments. Each chief was anxious to enlist the aid of a large medial lineage with famous soldiers. Mwambashi, of a Zighua lineage at Vugha, was known in the 1860's for the number and prowess of his sons. The King (Kimweriye Nyumbai) asked him to occupy a key outpost at the edge of the plains, on an invasion route. He held this position until after colonial conquest, and for his services he and his sons were exempted from building houses at court, they paid no tribute, and they benefited occasionally from the king's largesse. Kishasha, who lived at Vugha in the 1880's, lost two wives to kidnappers, who sold the women to slave traders in the plains. Kishasha's medial lineage was strong enough to recapture the women in a counter-raid. Weak and isolated minimal lineages could lose everything. Mavoa, an Mbugu of Magamba, was left with only three children and no wives out of what had been a large homestead, because he had no defense against slave raiders.

Cooperation between members of separate medial lineages within a maximal lineage, or between adult brothers within a medial lineage, is usually explained in terms of generational ideology. There is a very strong expectation that members of a single generation will be intimate with one another, and with members of alternating generations. Sentiments of distance and respect are thought appropriate between

members of adjacent generations. Because of this distinction, the multiplicity of generations within a lineage can be reduced to two generations. This can be seen in the pattern of names, according to which each generation within a lineage has a group of names, and these are repeated in alternating generations. An individual may be addressed, in everyday conversation, by any lineage name of his own or an alternating generation. Often the names themselves express the opposition between alternating and adjacent generations. Thus the name Shemweta means 'father of Mweta;' Shemweta's son may be called Mweta, and his grandson will be called Shemweta (in addition to whatever other lineage names exist, and whatever matrilineal names, and idiosyncratic names he is given).

Shemweta, the grandfather, might refer to his grandson as 'my companion Shemweta.' While Shemweta rarely ate with Mweta when he was an infant making a mess of himself, he is delighted to eat with young Shemweta. I have heard grandfathers express delight even at wiping the noses of their infant grandchildren.

The close relationship between alternating generations is expressed in the descent terminology, as seen in the following equivalencies (in terms of reference):

Baba: FF = eB = FFFBS = FFBS (older than speaker)

Tate Mkuu: FeB = FFF = FFBS (older than father)

Ng'wana: S = SSS = BS

It has been shown in section ii that there is a strict separation between the inheritance of widows and of personal effects on the one hand, which stay in the dead person's own or alternating generation, and between wealth and gardens on the other hand, which are transferred to an adjacent generation.

In sacrifice, the person who represents the maximal lineage must be of the same generation as the dead man for whom the rite is made. I knew members of a lineage which had performed a sacrifice for the ghost of a man who had been the last surviving member of his generation in the maximal lineage. For that one rite, the oldest of his son's sons took the part of the lineage elder, since he was 'of the same generation' as the dead man. During the rite, the young man was addressed by his own father as 'father.' One commonly hears terms of address which are not 'true' to the categories, but rather to relative age; it is impossible, however, to address a person of an adjacent generation by a term appropriate to the alternating generation (or vice versa).

It is clear that with all the forms of productive property kept within the minimal lineage, and with binding obligations for the payment of indemnity restricted to the minimal lineage, the generational ideology, which extends throughout the maximal lineage, has been important in supporting cooperation of members of the larger group. There are some ways in which distant lineage kinsmen of the same generation are thought closer to one another than father and son. In

the pre-colonial period, the generational ideology shored up the unity of half-brothers whose father was dead and who had to decide whether to leave a fund of unallocated wealth. The ideology also encouraged lineage kinsmen to spend and consume bridewealth together, and thus to join in a lineage mutual aid society.

## V

There have been drastic changes in the activities of medial and minimal lineages over the past eighty years. Today, virtually no medial lineages retain unallocated wealth; in virtually no cases is there leadership by the eldest of the group of brothers. In some cases, the men within a medial lineage will contribute toward the bridewealth of one another's sons, but even this is rare. The father of the bride, these days, keeps the bridewealth he is paid as his own. Feasts for the consumption of bridewealth have virtually disappeared.

It is possible to discern a number of reasons for these changes. Under colonial and post-colonial law, the individual criminal has been made to endure imprisonment, in place of an indemnity which could be paid by a group, and so the use of the medial lineage for insuring against indemnities has declined. In modern conditions there is no need for the medial lineage as a fighting group. Famine relief makes death as a result of crop failure much less likely, and pawning in famines has disappeared. In addition, there is now no consensus on the proper uses of wealth. In the pre-colonial period everyone

agreed that it was essential to use wealth for rites of passage and for sacrifice. Now some men sacrifice, others use the same wealth to pay school fees. Some men put their wealth in cattle, others use it to expand production of cash crops, a few buy lorries. It is no longer possible to say that every man in the medial lineage should leave his wealth in a group owned fund as cattle, to be used in an agreed manner for the preservation and procreation of life. In the late pre-colonial period the perception that members of a single descent group shared a common fate was valid. Today, the belief survives, only slightly diminished, that maximal lineage members are vulnerable as a group to mystical causes of misfortune, while the medial or maximal lineage tends much less than formerly to rise or fall as a unit.

## FOOTNOTES - CHAPTER TWO

<sup>1</sup>The mourning ceremonies seem not to have changed for a very long time. For written descriptions in the early colonial period, see LangHeinrich 1903: 230, 235; Storch 1895a: 312; Wohlrab 1929: 37-38; Dupré 1906.

<sup>2</sup>'Dying badly' is mentioned by Karasek 1911: 190.

<sup>3</sup>The sacrificial rite is said to have existed in the same form throughout the history of the kingdom. This is probably so. It is clear from the written records that the rite, and its use in defining the lineage, have remained virtually unchanged during the past eighty years (Riese n.d.; K. Wohlrab 1929: 40-48; Becker 1896).

<sup>4</sup>This account is based on oral traditions, as well as LangHeinrich 1903, and Wohlrab 1918.

<sup>5</sup>The statements about the sole liability of the minimal lineage are based on oral reports, as supported by LangHeinrich 1903 and Wohlrab 1918 in which information about jural rules is noted. There are, in addition, actual cases recorded in the written documents. Krapf reported the case of a man found guilty of witchcraft in 1848 (1964: part 2, 110). The man and his children were killed, and at the time Krapf passed, the King's soldiers were hunting for the man's wife, who was also a witch. In later years, with the increase in importance of the slave trade, only a man would have been killed, and his dependents sold, as in a witchcraft case described in the Bethel Mission archives (Tagebuch Neu Bethel, 11 December 1895). In both of these cases, the most extreme measures were taken against the head of the minimal lineage and his children, but the other agnatic relations were not punished in any way. In the case of a man who attacked the King's tribute collectors and then fled into the bush in 1852, the man's 'relations' were held prisoner and his children sold. The 'relations' were probably those of the man's agnates who lived near him. The King (Kimweri ye Nyumbai) ordered that they be held only until the criminal himself was found (Krapf 1964: part 2, 304).

<sup>6</sup>LangHeinrich 1903; Wohlrab 1918. For the economics of warfare, see New 1873: 334-335. The continuous record of famines is from the archives of the Universities' Mission to Central Africa (U.M.C.A.), located at the United Society for the Propagation of the Gospel, London. For cases of pawnship in famine, see Bethel MS: Tagebuch Neu Bethel, 23/24 February 1895 and 17 February 1894. The discussion relies also on oral traditions.

## CHAPTER THREE

### ALLIANCE, DOMESTIC GROUPS, AND TERRITORIAL INTEGRATION

The anthropologist performs two separate tasks, when describing marriage and the formation of local networks of relationship in an alien society. On the one hand, he must describe rules and categories -- those elements of social structure which are largely taken for granted by the people of the society in question, but which need to be translated and explicated for the reader, whose social and cultural distance from the subject is enormous. On the other hand, he must describe the way in which choices are made, given the existence and acceptance of the structure of rules and categories. These choices may vary from one time to another, because of changing economic and demographic circumstances, and they vary within a particular setting, because of the personal circumstances and personal preferences of individuals. In a sense, this entire thesis is nothing but an exploration of structure and choice in the political life of the Shambaa. But the two kinds of description are brought into an unusually close relationship in this chapter, because I am attempting here to summarize the characteristics of a large and important area of Shambaa social life. There is no room for the leisurely exploration of one or the other kind of analysis. This chapter is, then, an attempt at a summary of social phenomena, the understanding of which is essential for a knowledge of Shambaa political structure. It is characterized by the alternation between descriptions first of rules and conceptions, then of the implications of these rules, and the variability of choice.

## I

The Shambaa marriage rule is defined in relation to a series of payments made by the groom and members of his lineage to the bride and some of her relations. There is a single, simple rule for the determination of prohibited marriages: a marriage may never be made in which a giver of bridewealth would simultaneously be a receiver of bridewealth. The rule that members of a maximal lineage may not marry one another can be restated with reference to payments: since the entire maximal lineage may contribute toward the bridewealth together, marriage within the lineage would result in a payment by the lineage to itself, and therefore prohibited. Lineage exogamy is sometimes explained in these terms by Shambaa informants. The transfer of wealth is an indispensable element in marriage. There are many cases in which two lineages give one another women: where a man from lineage A takes a wife from lineage B, at the same time that a man from B is, in turn, taking a wife from A. But at no point may the payments be eliminated in an exchange of women.

There is no distinction, in the Shambaa language, between incest and a violation of the rules of exogamy, although a difference is recognized in the community's attitude toward sexual intercourse between near relations, as opposed to distant ones. In either case, the act is described as kuuwiya mai yako ng'wenye, 'to take one's own wealth,' or to turn in upon oneself. Incest is said to lead to barrenness, but there is no legal action which can be taken against the violators because in Shambaa law there must always be a complainant of a different lineage from that of the defendant (see chapter vii). In one reported

incident of father-daughter incest a number of years ago, the case came to court and the father brazened it out. He admitted to having committed the act, but asked to have the case thrown out of court because there was no complainant. The case was dismissed, but the man became an outcast in his own community.

There are two sets of payments made by a man and his agnates to the father of his wife. The first set is supposed to be made before the woman leaves her father's home, and its payment leads to the transfer of a number of rights in the woman: rights to her labour, sexual rights, the right to claim (and make payments for) future offspring, and the right to request that her relations perform rituals for the welfare of her children. The second set of payments is made after the woman gives birth to her first child; these payments establish the membership of the child (and of all future children) in its father's lineage. The payments on the birth of a child also establish an enduring relationship between the lineages of husband and wife, because the calves of the 'cow of affinity' (which will be discussed in detail below) are shared by the members of the wife's natal patrilineage, and by her own sons.

Each of the two major sets of payments comprises numerous transactions, all of them named so as to refer to the purpose of every payment. The first reaction of an inexperienced field worker is one of great excitement, for here, it seems, is a body of data which, if reported fully and accurately, will give the authentic Shambaa view of the nature of marriage. But in fact there are great obstacles to this approach. The payments have varied significantly in amount over the

past eighty years, they vary both in name and amount from place to place, and they even vary in name from one marriage to another within the same locality.

The possibility of variation in bridewealth is often consciously manipulated. The young men of the former chiefdom of Mshihwi, for example, often go for their education to the Catholic school at Gare, where bridewealth payments are considerably lower than in their home chiefdom. These men often marry Gare women. The fathers of the men would prefer to postpone their sons' marriages, but the sons make the unanswerable argument that if they wait and marry Mshihwi girls, their marriages will be much more expensive. Even within a single village, bridewealth can vary. If a young man wants to marry a woman of his mother's patrilineage, a marriage which is frowned upon, bridewealth is made more expensive. Named payments which are rarely heard of are then reintroduced, so that the young man's father can insist that he has not the resources to pay for the marriage.

Alongside the wild profusion of names and customs for separate bridewealth payments, there is a strong tendency towards simplification of bridewealth: a number of small payments may be commuted for a goat, and then later the value of the goat is included in a larger lump payment in cash or livestock. One example from Mshihwi will suffice to illustrate this process. In the late pre-colonial period, the betrothal arrangements began with a series of three feasts which the young man and his father provided for the girl's father, who invited his neighbours, friends, and lineage companions. One feast was named ha mbuyangu, 'at the village of my blood partner.' Another was uona

chengo, 'meet the lineage.' A number of names have been reported for the third feast. For each of these feasts, the young man had to provide twelve large gourds of sugar cane wine, a rooster, and a hen. Over the years, the men of Mshihwi simplified this, ended the feasts, and converted the thirty-six gourds of wine to one bull, called nkoma ushezi, 'end the wine-making'; they also converted the six chickens to a billy goat. A young man of the same village as one informant on the gourds of wine knew only that he needed 600 shillings for the girl's father before marriage, or six bulls. He was not aware that one of those bulls was 'end the wine-making,' although he remembered with both annoyance and respect that the father of his first wife had made him pay pot after pot of honey, in one of the traditional payments. The tendency toward simplification, and the establishment of cash equivalents, are not recent developments. Dahlgrün, in 1903, reported that in place of sugar cane wine one could pay a big billy goat or four rupees (228). One of the few men who still enjoys manipulating bridewealth names replied, when asked why he bothered, 'We are playing with wealth.'

In spite of the great variations in the names and amounts of the payments, it is possible to isolate the fundamental features of bridewealth. This summary is based on a review of observations of bridewealth negotiations and reports collected from informants in two widely separated chiefdoms, together with published accounts of bridewealth as it existed in the past (Dahlgrün 1903; LangHeinrich 1903; Dupré n.d.: 31-45; Karasek 1911: 186-191; Karasek 1918-1922: 82-89; Wohlrab 1918; Cory 1951: part ii). The most important elements of bridewealth are

the following, given roughly in the order of their payment.

Payments made before the bride moves to the groom's house:

1. In the past\* the young man and his father gave wine and livestock for a series of feasts which the girl's father shared with his neighbours and relations. One feast was solely for members of the girl's patrilineage. Today, these feasts have disappeared, and the payments are made in livestock or cash, which is kept by the father of the girl.
2. There were small payments made in the past to the girl's mother's brother (mtumba). These have disappeared in most places, with the decline of the sacrificial rite made by the woman's mother's brother in some cases of infertility. This payment, together with a small feast for the girl's brothers, is included in the large payment to the girl's father.
3. There are several payments made to the girl's mother, because she cared for her daughter, carried the infant on her back, and fed her. These have remained relatively unchanged, except for the payment, these days, of a goat, instead of the carrying cloth which used to be given. An additional goat is paid in place of the dried impala meat formerly required. Cash equivalents have been established, although they vary locally. One in this series of payments is made only if the bride proves to be a virgin.
4. The young man gives a number of gifts to his fiancée. These vary widely. They were formerly insignificant or non-existent, and

---

\*In this account of bridewealth, when mention is made of 'the past,' specific reference is intended to the period between 1880 and 1915.

they are growing constantly more expensive.

5. At the marriage celebration, the young man's relations give the bride a number of cloths in which to dress. In pre-colonial times, before the introduction of cloth, she was given a softened, carefully worked skin to wear. At the same time, the girl's mother and father give her household implements.

Payments made after the marriage:

6. Furugha and dong'a -- the furugha is a nanny-goat, and the dong'a a kid. This payment establishes the membership of the first child of the marriage in its father's lineage. It is the only payment which the woman's father is anxious not to collect too soon. If it is paid during the woman's first pregnancy, only a pregnant goat need be paid. If it is paid after the birth of the child, the payment includes a she-goat, and a kid of the same sex as the infant. If two children have been born, two kids must be paid. Once the payment is made, it is never supplemented. It is properly paid for the first child, and then the affiliation of future children is determined by the payment of ukwe (#7). In contrast to the payments before the marriage, those made after the marriage have been relatively unchanged, except for the development, and inflation, of cash equivalents.

7. The final payment is called ukwe, literally 'affinity.' This is not a simple payment which is completed and forgotten, but the first of a complex series of related transactions which continue over years. The obligations with regard to the 'cow of affinity' ensure the continuing involvement of the men of the wife's natal patrilineage in the affairs of her husband's lineage.

Ukwe is a cow which has not yet had calves. It should be paid at the birth of the woman's first child, or soon after. Once the payment is made, all of the woman's future children belong to the husband's patrilineage. The woman's father may not sell or slaughter the cow of affinity, but must keep it to breed calves. There are two groups of young men who may ask to use the calves in order to make bridewealth payments (and best of all ukwe payments) for their own first wives: the full brothers of the woman for whom it was paid, or their sons, and later the woman's own sons. If the cow of affinity dies before bearing an abundant number of calves, the husband who gave the original cow must provide another. When the cow has finished its breeding period, it is returned to the sons of the woman for whom it was originally paid. The meat and hide of the dead ukwe cow are theirs in any case.

The career of the cow of affinity is parallel to the career of the woman for whom it was paid. The cow originates in one lineage, serves for its mature lifetime in a second lineage, and returns at death to the original one. A woman similarly bears children in a lineage which is not her own, and then after her death her personal effects are inherited by a member of her natal patrilineage. And just as the calves go on to other lineages as ukwe in their turn, the woman's daughters are given as wives to other lineages.

Karasek reported a custom which I have never seen practiced or heard mentioned: when the original cow had born many calves, and was returned to its original lineage, the woman's father or brother returned with it a cow which had not yet born calves, which repeated the ukwe's career in reverse. This difference from current practice is congruent

with the general tendency to refuse to pay ukwe again when the original cow dies. In some areas the new practice is justified by the payment of an additional goat (called tuni, 'the knife') with ukwe, which absolves the payer from all responsibility upon the death of the cow of affinity.

There is a proverb: kufa usona, ukwe heufa, which means 'usona dies, but ukwe never dies.' The proverb depends for its subtlety on the fact that usona means both marriage, and bridewealth paid before the bride is taken to her husband's house, while ukwe means both the cow, and the relationship of affinity. The reciprocal term of reference for the relationship wife's father-daughter's husband is mkwe, ukwe being the abstract noun. The proverb, then, has a number of meanings. It once meant that the livestock paid in bridewealth was killed and eaten, while the cow of affinity was left to live. It also means that bridewealth, once paid, is done with, while ukwe is paid over and over. And it means that even when a marriage is ended by divorce, the relationship of affinity between the two lineages continues, because of their joint interest in the children.

In addition to its importance as a sign of the relationship between the two lineages, the cow of affinity is one of the most important practical interests which keeps the lineages working together, sustaining the awareness among the woman's father and brothers that they must concern themselves with her affairs even though she has moved to another man's household. The woman has the right, especially after her father's death, to take the cow and its offspring from her brother, and to use it solely for her own sons. A man will freely contribute a goat at the rites of passage

of his daughter's children so that she should not think he is using the ukwe only for his own purposes. (For a case in which a woman demanded the return of her ukwe, see p.123) The disposition of ukwe is also an indicator of the quality of the relationship between male affines. The son of one of my informants at Vugha had married the daughter of a close neighbour of mine. The neighbour had paid the school fees of his daughter's children-- an unusual and generous act. When the cow of affinity died, the father of the young man made a point of paying again.

Because of the importance of ukwe in determining the lineage membership of children, the cow is often paid a second time, voluntarily, by a man who inherits a young wife and has children with her. A man who inherits a widow does not raise children to the household of the dead man, for biological paternity is overwhelmingly important to the Shambaa. Even the adulterous lover of a married woman has the right to pay so that her children by him will become members of his lineage.\*

---

\*Most Shambaa are uncertain in their descriptions of the biology of procreation, although they believe strongly that the man and the woman play parts which are roughly equal. One man, when questioned about the way a baby is formed inside its mother, replied, 'There is no way of knowing what goes on inside the body of a woman, except for the customary definitions by which we organize our lives.' This may have been a reference to the woman's right to state the name of the infant's father in disputes over paternity. It is often said that the child's right side is from his father, and his left from his mother, with the sexual organs from the parent of the appropriate sex. I asked one man how come my right side looks exactly like my left. His answer was, 'Your mother has an eye on her left side, your father has an eye on his right side, and you have two eyes.' It is important, at any rate, for a child to belong to the lineage of its biological father, 'for it is his own blood.' Biological paternity is said to determine the quality of the relationship between father and son. If one's son is disobedient, one knows that he must have been fathered by some other man. Biological paternity appears to have been as important for lineage

It is the woman's unquestioned right, however, to decide which man is really the father of her children. The quality of a woman's relationship with her husband would presumably need to be very poor before she would name an adulterer as father of her child. A man who inherits a wife, has children with her, and does not pay to legitimize the descent of those children, has no rights in the bridewealth of the daughters, and leaves his sons without rights in his land or livestock. The children are still legally attached to the lineage segment of their mother's deceased husband. Their genitor's sons by his other wives can deny their half brothers a portion of the inheritance, saying, 'You were born (i.e. filiated) with the cows of father's brother.' The disinherited men must then make claims on the land of their mother's first husband. There was a case at Vugha, several years before I was there, of a man who had not paid to filiate his children by his inherited wife, and therefore lost his biological daughter's bridewealth to the inherited wife's son by her first husband.

The payments after marriage, for the filiation of the children and the establishment of enduring affinity, have evolved in quite a different manner from the payments before marriage. The cow of affinity, as well as furugha and dong'a (payment #6); have remained largely unchanged as named customary payments, although cash equivalents may be paid. It has been shown above that the bridewealth paid before marriage, by contrast, has undergone simplification, with the elimination

---

filiation in the early colonial period as it is today. Then, as now, filiation was legitimized by livestock payments (LangHeinrich 1903: 232).

of many customary payments. The simplified payments have been very greatly inflated, even when reckoned in terms of livestock and not cash equivalents. The inflation has been especially noticeable in the payment made to the bride's father before marriage. Dahlgrün (1903) and Karasek (1918-1922: 82) both reported that in the first decade of the twentieth century, this payment consisted of either many calabashes of sugar cane wine or a single goat. LangHeinrich was told at Vugha in 1896 that this payment varied between one goat and sugar cane wine at the lowest possible level, to a bull calf, a young he-goat and wine at the highest (1903: 226). By 1946, the payments included sugar cane wine and other customary payments, in addition to two bulls (Cory 1951: para. 3). By 1968 the payments were usually about five or six bulls, but never less than three or more than ten. Over the same period the post-marital payments for filiation have remained constant.

It is impossible, within the scope of this work, to offer a definitive explanation for the contrasting development of payments before and after marriage. Such an explanation would require a detailed analysis of special forms of marriage (e.g. marriage to a divorcée), of those payments returned to the groom in case of divorce, of the disposal of adultery fines, and of many other transactions related to marriage. I would suggest, however, the notion that the crucial difference between the payments before marriage and those after marriage is that the former serve to ration a scarce resource, and the latter do not. (Cf. Douglas 1967.)

In a polygynous society there must be some way to determine who is

to have many wives, and who is to have none. In the Shambaa case, the answer is quite simply that the man who is able to get a woman's consent, and to pay bridewealth, can marry. Since money equivalents have been established for bridewealth cattle, it has become possible for individual men to make economic decisions on the relative value of a wife. Some men choose to use the amount of wealth it would take to marry in order to start a small shop. Other men use equivalent amounts of wealth to buy farms. It is difficult to get precise information about the price of land in 1900. But it is clear that a piece of land which could be bought for a goat (or its equivalent) then, would be valued at the price of at least several bulls now. What this means is that if the cost of bridewealth had remained the same over the past seventy years, the balance between marriage and other possible choices would have changed drastically, to the point where bridewealth would no longer function as a rationing device. As it is, the likelihood of a young Shambaa man becoming a shop owner is much higher now than it was then. The cost of the cow of affinity has not risen over the same period because everyone recognizes that when a man fathers a child, he will take the child into his own patrilineage. The allocation of children is not in question.

There are implications of the rising cost of bridewealth for relations between fathers and sons. Livestock and money, it has been shown, are included in the category mai -- 'wealth.' There is a tendency, because of the character of transactions in wealth, for possessions in this medium to be concentrated among the older men. Bridewealth is paid to the father of a girl, not to her brother. And the transfer of wealth from father to sons takes place only after the father's death, as the

inheritance (see below). Since the father provides the bridewealth for his son's first wife, the father decides on when his son is to marry. Conflict is greatest in this relationship, and the father's power over his grown son is greatest, just before the son marries his first wife. Elopement is one possible way out for the son, but still, bridewealth must ultimately be paid. It has become progressively easier, during the past seventy years, for a young man to earn money by wage labour, and by the cultivation of cash crops. At the same time the amount of bridewealth has constantly increased, so that it tends usually to remain just beyond the grasp of most young men, who still need the help of their fathers in making the payments for their first wives. As the amount of bridewealth has increased, its use for feasting has declined. The bride's father now keeps the wealth. This has tended to keep the concentration of wealth in the hands of the older men, at the same time that young men have found new sources of wealth. (Another reason for the decline of feasting is given in chapter ii) The dominant position of old men in these transactions can be seen in fig. 5, which shows that there is a strong correlation between polygyny and advancing age. Of the twelve men between 20 and 29 who were unmarried, nine happened to be living away from home temporarily at the time the census was taken, some working at wage labour, presumably to earn part of their bridewealth, a few studying in secondary school, and some living away from home because they could not get along with their fathers.

The relationship between economic conditions and the amount of bridewealth may account, to a certain extent, for the variation in types and names of payments. In this situation, where the sphere of exchange

of goods paid as bridewealth is not insulated from the rest of the economy, there are two possible relationships between categories of payments and the amount of payments. One is the possibility of retaining a few unvarying categories, but allowing for great variation in the actual payments associated with each category. The other possibility is the retention of a fairly close equivalency between the name for a payment and the amount of the payment; if this happens, it is acknowledged that different named payments are made in different marriages. In the Shambaa case, as described above, both possibilities were realized, with an overwhelming predominance of the second. One result has been a judgment by the Shambaa themselves that the names for bridewealth payments before marriage are trivial in meaning. The ukwe payment, by contrast, has remained constant, and the name is a significant one, referred to in cases, proverbs, and indigenous descriptions of social structure. In bridewealth before marriage, the principle is abstract, and the practice variable; with ukwe, the principle

Man's Age	No Wives	One Wife	More Than One Wife	Total Number of Wives	Average Number of Wives per Man
20-29	12 (44.5%)	10 (37%)	5 (18.5%)	21	0.8
30-39	2 (10%)	12 (60%)	6 (30%)	24	1.2
40-49	0	14 (50%)	14 (50%)	46	1.6
50-59	0	6 (40%)	9 (60%)	32	2.1
60-69	0	2 (17%)	10 (83%)	30	2.5
70+	0	2 (28.5%)	5 (71.5%)	19	2.7

Fig. 5 Distribution of Wives to Men of Different Age Groups  
(Muslim and Pagan)

N.B. In addition to those listed, the men surveyed had 8 unmarried sons between the ages of 20 and 29 living permanently outside the chiefdom.

is expressed substantively in action and category. Both the abstract and the concrete principles are characteristically Shambaa. The difference is accounted for by whether or not it is possible to retain actions which are relatively stable and unvarying.

The logic of the bridewealth payments leads to the prohibition of marriage with two sets of kinsmen. First there is the obvious prohibition on marrying members of one's own lineage, who may contribute towards one's bridewealth, and who consume the livestock used in feasting. Second, the payment to the mother's brother of the bride (payment #2, above), and the complex series of transactions with the cow of affinity, make cross cousin marriage improper.

In cases of father's sister's daughter (FZD) marriage, the groom's father is at the same time the mother's brother of the bride, and so he is put into the position of having to make a payment (#2) to himself, 'to take his own wealth,' turning in upon himself in violation of the rule of exogamy. But in fact the payment to the bride's mother's brother has largely disappeared. This has not led to a relaxation of the rule on FZD marriage, however, because the series of transactions involving the cow of affinity cannot be executed in either kind of cross cousin marriage: to the father's sister's daughter, or to the mother's brother's daughter (MBD). A young man shares rights in his mother's cow of affinity with his mother's brother, who, in MBD marriage, would be taking the offspring of this cow, to give to his sister's son, for payment to himself. The same situation occurs in reverse in FZD marriage, for a young man shares the cow of affinity of his father's sister with her sons.

The firm prohibition against cross cousin marriage applies only to the children of the actual MBD or FZD, and not to the entire category, because the prohibition is not stated in terms of the categories, but only prohibits 'taking one's own wealth.' When the cow of affinity is paid for a woman, it is used only by her brothers or their sons, or by her own sons. The rest of the woman's natal patrilineage has no rights in the cow of affinity, nor does the rest of her husband's patrilineage. Marriages between distant cross cousins are therefore not prohibited, although they are strongly discouraged. When such a marriage is made, the groom pays an additional billy-goat, called nkoma ndughu, 'end the relationship.' One informant explained in the following terms why cross cousin marriage is unfortunate: 'This marriage is bad because your father's sister (nyokwe ngazi) has changed into your wife's mother (mkweo). Two sets of relations have returned together.' Another informant explained, 'Your wife's father (mkweo) is your equal, because you are giving him wealth. But it is improper to buy things from your father (isho).' An additional difficulty, in marriage with someone in a cross cousin category, is that one cannot ask one's mother's brother to make a payment to a member of his own lineage, nor can one ask one's father's sister to make a payment to a member of her husband's lineage. An individual who makes a cross cousin marriage is required, therefore, to forgo the use of livestock to which he would otherwise have rights. In actual practice, cross cousin marriages are relatively rare. They accounted for only 4% of all marriages reported in the 1968 census.\*

---

\* I collected the census data in 1968, using a questionnaire which I constructed after almost two years of observing Shambaa life, and of collecting statements on descent, alliance, and residence. I collected the data myself from 138 men. This was not a sample, but included all the men in my own village (Bazo, Vugha), and within a limited area around it. Each man informed me about himself and his dependants. I knew virtually all the men, some quite well, before the census.

## II

The marriage rule having been defined, and some of its implications for property rights having been explored, it is possible to turn to a description of the domestic group created through marriage. This change in subject matter will be accompanied by a shift in the style of description. The marriage rule, as described on p. 102, is simple and clear, and it is strictly adhered to, in all cases I have seen, all the time. The major analytic task was to discover the abstract rule, and then to explore the invarying results of its application. In matters of residence choice, however, there is a range of variation. The categories, definitions, and rules concerning the marriage prohibition and the constitution of descent groups determine the range of options among which individuals may choose. A son may live in his father's village, or in a nearby village, or in a different chiefdom. Each choice has certain consequences. A man may have all his wives living together in one village, or his wives may have residences in several villages. These phenomena, unlike the invarying regularity of the marriage rule, can only be described in terms of relative probability. They are statistical rather than structural regularities -- tendencies towards some types of behaviour rather than moral necessities.

In a polygynous family, each wife has her own house (nyumba), and all the houses are loosely grouped together usually as part of a larger village. A man does not have a house of his own, but moves around to sleep in the houses of different wives on different nights. Children who are younger than about eight years sleep in the houses of their mothers. The sleeping quarters of older children have changed consid-

erably over the past hundred years. In the nineteenth century, each village had two bachelors' houses (mabweni, s. bweni), one for boys and one for girls. Today the boys' bweni survives in some places; in others, the women of a household simply move around every night, leaving one house empty for the boys. There are a few cases in which a man has built an additional house for himself and for his sons. This is a very recent development.

Many of the terms denoting domestic social units or conditions refer to the appropriate portion of the habitation. Nyumba, which literally means 'house,' also means a married woman and her children, or a set of full siblings. Unyumba means marriage. The house of a man's senior wife is called 'the great house,' or 'the senior house' (nyumba nkuu). Her children are referred to by the same term. A married person is called an mnyumba, one who has a house, as opposed to an mbweni -- a person who sleeps in the bachelors' house. The open yard shared by a group of houses is called chengo or chengoi, a word also used to mean a lineage of any span (see chapter ii).<sup>1</sup>

In the pre-colonial period, every local lineage-based group was required to maintain a house at a royal village or town. But aside from this house, and the woman sent to maintain it, the polygynous family appears always to have been a compact spatial unit within a village, as it is today. In my census of 1968, there were only six cases in which wives of a single husband lived in separate villages. Three of these were separations, in which a wife had moved back to her parents, awaiting either divorce or reconciliation. In two of the remaining three cases, there were special circumstances in the economy of the polygynous

family. In one case, the husband worked in the national capital, Dar es Salaam, and had one wife with him, and one in Shambaai to look after his farms. In another case, a man lived with one wife in his natal village, and had a second wife who lived at his shop about a mile away, at a location which was commercially more promising. The final case was of a man who was more than eighty years old, but who was still vigorous. He lived with his young wife and infant children, while his senior wife lived about a quarter of a mile away, with some of her grown sons.

There is a general assumption today, except among Christians, that most men will ultimately have at least two wives. This seems to have been true in the last decades of the nineteenth century as well (Lang-Heinrich 1903: 225). The practice of polygyny, as recorded in the census of 1968, is given in fig. 6.

Number of Wives per Man	Number of Men
One	46
Two	33
Three	8
Four	5
Five	2
Six	<u>2</u>
	Total Census 96

Fig. 6 The Number of Wives per Man (Muslim and Pagan)\*

---

\*In counting the number of a man's wives I included either a wife who was living in the man's village at the time of the census, or a wife who had procreated children with him. Thus a dead woman who bore children

In order to understand the division of labour within the domestic group, and the transfer of property during the stages in the development of the domestic group, it is necessary to remember the close association between wealth (mai, see p. 94 ) and the increase of the agnatic group. A concern with wealth, the care of livestock, preparation for court cases over rights in wealth, are seen as the proper work of men. Bridewealth is, after all, wealth given by one group of men to another in exchange for rights in women.

In the everyday household economy, it is the men who are required to provide the meat or vegetable relish (mbogha) which is eaten along with the staple. This is because the best relish, the archetypal relish, is considered to be meat, which is obtained either through hunting, which is men's work, or through the slaughter of livestock wealth. The women, who are expected to do the regular, repetitive daily farming work, provide the staple for each meal. The men do the heavy clearing of farms, and other work which is irregular and intermittent. The men are also responsible for the care of crops which are cultivated for wealth. In the nineteenth century tobacco was a man's crop, as it is today, although it is no longer as important as it was then. When coffee was introduced, its cultivation was immediately made one of the masculine activities.

Within the polygynous family, there are lines of separation, and possible tension, between matricentral houses. Each house has a separate

---

during her lifetime was counted, but an inherited widow who did not live with her heir, and had no children by him, was not counted. In other words, marriages were counted if they had continuing implications in the realm of property relations.

body of wealth, which derives from those bridewealth payments made to the mother of the bride, if the house has young women of marriageable age, and from the cow of affinity, in which the young men share rights with their mother's brothers. The existence of separate bodies of ukwe wealth in each matricentral house means that each set of full brothers has a unique set of unmarriageable women (MBD's), who may be married by their half brothers, the sons of their mother's co-wives. Co-wives may never be sisters. If sisters married the same man, it would be difficult to retain separate funds of ukwe wealth for their respective matricentral houses. In addition, there is a special form of mystical homicide which sisters are said to employ against a man if they discover that, even by accident, they have both slept with the same man.

The rights of a woman in the cow of affinity, or in bridewealth which she receives for her daughters, are limited. The disposition of this wealth resembles, in some respects, the disposition of unallocated wealth within the patrilineage. The woman may use a goat to make strengthening broth for her father if he is seriously ill, and she may use it for contributions towards the bridewealth of her sons, but she may not make contributions towards the bridewealth of young siblings or brothers' sons in her natal patrilineage. This is forbidden, it is said, 'because it would bring about the increase of another man's lineage.' The limitation of the woman's right to dispose of her wealth is in sharp contrast with a man's right to use allocated wealth. At Bazo, near Vugha, in 1967-1968 everyone had great admiration for a man who had paid bride-wealth for the first wife of his orphaned sister's son.

Women are thought, in any case, to be more narrowly interested in the

welfare of their sons than men. It is expected that in any dispute in which the rights of a woman's sons conflict with the rights of young men in her natal patrilineage, she will always support her sons. The way in which this works can be seen from the case of a woman whom I shall call M, who lived near Vugha. The dispute developed over the progeny of the cow of affinity. When the cow had born a bull calf and a heifer, the woman's brother asked to borrow a bull, so that he could take a second wife. This was not a proper use for ukwe, which should have gone to his sons, and so it was given as a loan. Some time passed, and the cow of affinity calved again; another heifer. The woman's brother asked for the heifer, and she refused. She was reported to have said, 'My house is full of young men, and I have only one daughter. If all the cows go to your household, my sons will be unable to find bridewealth.' She took her brother to court and sued successfully for the return of her bull. But then the cows began to sicken. She suspected her brother's sons of sorcery. As the cows succumbed to disease, she sold them to the butcher, and saved the proceeds. During the time I knew her, she was using the money for gifts of meat to her sons' wives when they gave birth, for meat and meat broth are supposed to restore a woman to health after childbirth, and therefore to increase the likelihood of the infant's survival.

The quality of the relationship between co-wives within a polygynous family and between the children of the separate matricentral houses, is recognized as being extremely variable. Some trivial examples will illustrate how relations between houses vary. There was a period of about two months when I lived in the household of a man with two wives. I slept in a spare room, and took all my meals with the head of the household, his

son, and my assistant. It quickly became clear that his two wives were not on friendly terms. One day, when my host was out, a loud row broke out in the kitchen of one of his wives, the mother of a teenaged son and daughter. The son had been sent home the day before with two bundles of meat, one for each wife. He had put them both in his mother's kitchen, and during the night a cat had eaten them. When the only child of the other house, a teenaged daughter, came to ask her half-sister for one bundle of meat, so that she could begin to cook, she was simply told, there is no meat. The argument got louder, until finally the girl whose brother had brought the meat said, 'Tell your brother to bring you meat,' a terrible insult, for only the speaker had a brother in her house. They shouted obscenities about one another's mothers, who were not present. Finally their father arrived home and hit the provocatrice. My assistant's wife assured me that if the two mothers had been there they would have fought. In contrast, one man I knew had two wives who got along so well that they farmed a single garden together, and shared the crops after harvest. Much more commonly, sympathetic co-wives take turns working one another's gardens, with each wife retaining her crops. Shambaa men say that the quality of relations between co-wives depends on the vigour with which their husband discourages conflict, and on his skill at demonstrating his lack of favoritism, especially in the distribution of material goods.

Whatever the sentiments between co-wives, and between the sets of children of co-wives, it is a basic fact of Shambaa domestic life that matricentral houses often relate to one another as groups. Hostility between mothers leads to hostility among half-siblings; cooperation and affection among half-siblings are usually tied to friendly relations

between co-wives. The separateness of the houses with regard to affective relationships is parallel to the separateness with regard to wealth, because of the law of affinity. It is not being suggested here that the one led to the other, but merely that there is a congruence. The separateness of the houses is recognized and given special force in the realm of sexuality. If a man sleeps with one of his wives, he may not then touch the infant of a different wife until he has changed all his clothes, and washed his entire body. If he does so without changing clothes, it is believed that the child will never walk.

The matricentral houses are the instruments for the transfer of land from a father to his sons. The progressive transfer of land begins when the man marries and gives his new wife gardens. When the woman's children are young, her garden plots are the main source of their food. As the children grow older, they begin to help her to farm. Once the woman's sons are mature, with dependents of their own, they work their mother's gardens and keep some of the produce to help support their own households. And they ultimately inherit their mother's gardens. When a husband gives his new wife a garden, then, he is already determining the path of its ultimate inheritance. If a woman dies while her children are still young, her gardens are kept separate in the interests of her sons. I knew one woman who had taken care of her dead co-wife's children, who were, by the time I knew them, young married people. When they were young, the woman's own children and those of her dead co-wife had all eaten together, and they consumed food from the gardens of both houses. When the sons of both houses married, however, the land belonging to the two houses was separated again, and each group of sons now lives off the gardens of its own mother.

Crops on the man's land are used for cash, and for emergencies. Since each wife has her own land, it is considered that her children will be well or poorly fed according to how industrious she is. The husband in a polygynous household must be seen to be even-handed in his distribution of food from his own garden. If one wife suffers a crop failure, there is no way the husband can help her without helping the other less needy wives. He must divide food evenly among them, and then, if they wish, they may give part of their own shares to their co-wife.

A second transfer of land from the father to his son takes place at the time of the son's marriage. A father gives his son land so that the son can support his wife and children. This land may be taken from the gardens of the young man's mother; it may be taken from the father's own land; or it may be wilderness, cultivated for the purpose. The importance of this transfer, and the value of the land, were almost as great in the pre-colonial period as they are now. Pressure on the land is clearly much heavier now than it was in the pre-colonial period, but even then land near an established village was heavily used, and had a sale value. If a father wanted to keep his sons nearby, he had to provide land, much as a chief had to provide land near his capital if he wanted to keep his followers (see pp. 33 ). If there was not enough land near the village, some sons would have to move away, to clear land in some less densely populated, and therefore less desirable place. The only difference in this respect between the 1880's and the 1960's is that in the earlier period a man could find cultivable wilderness in Shambaai, while today free land is available only in the plains.

As the sons all reach maturity, and the father has fewer young children to support, and fewer immediate needs, he may give more of his land to his sons, keeping only a few small gardens for himself. I knew one very old man who had sold his land to his sons. He did this because he thought there would be less likelihood of conflict after his death if each son had bought land. The old man also wanted cash for his immediate needs. This, however, was certainly not an orthodox way of transferring land. No matter how old a man gets, he keeps his own banana garden, and it is here that he and then his children will be buried, if they do not 'die badly.'

During the lifetime of a father, there are conflicting pressures on his adult sons, influencing their choice of residence. The father possesses valuable land, some of it allocated to his wives, some of it in his sole possession. Because land cannot be sold to outsiders, effective use of the father's gardens will pass to those of his sons who do not move away. The situation is further dependent on the Shambaa idea of the proper relationship between fathers and sons, in which the father has extreme authority. It is the father's place to command, and the son's place to obey. This may sound like a simplification, but it is not. The ultimate sanction enforcing the father's authority is ute, the father's curse. If a son repeatedly disobeys his father, the father can curse his son by pointing to his own genitals and saying, 'If you did not come from here, may you be accepted as a companion by your fellows, but if you came from here may you wander like a fool. You may sow, but you will not reap.' The son (or daughter), it is said, then wanders about Shambaai aimlessly, a harmless fool pitied by all. There are a number of such

wandering fools in Shambaai, whose condition is attributed to the father's curse. The curse may not be used arbitrarily. If a son obeys his father's every wish and is cursed without reason, then the curse is believed to rebound and affect the unjust father. The importance of the father's authority has several possible effects on the residence of the sons, depending on the constitution and size of the extended family, and on the personalities of the members. Some mature men, whose fathers are arbitrary and demanding, move to other villages in the same chiefdom, which are usually no more than a mile and a half from the paternal homestead. Any man's farms, it will be remembered, are scattered through an area within about a five mile radius of his village. A son, by moving a mile, remains fairly near the midpoint, while avoiding daily conflict with his father. A quite different effect of the existence of the father's authority is the reduction of open conflict between his sons, whose differences he composes. There may be more of a tendency for the separate sons to go their own ways after the death of their father.

In addition to the sons who live with their father, and those who live in nearby villages, there are, these days, often some sons who live in the warm plains zone (nyika), and some who work for wages in the towns of Tanzania. The presence of a son in the plains insures that in times of a good plains crop and a poor mountain crop, the extended family will have enough to eat. Sons who move to the plains, or who take up wage labour, often maintain houses and gardens in the mountains, in or near the village of their father. Sons who simply cannot get along with their fathers often move away altogether, and it is usually understood, in such a case, that the father will not pay bridewealth for his son's first wife.

It has been argued that Shambaa ideas of descent, and of the authority of the father, as well as the rules concerning rights in land, when operating within the environment of Shambaai, generate several options for the choice of residence by men. The data given in figs. 7-8 show the relative frequency with which the choices were made, in Vugha, in 1968. It can be seen that there is a strong tendency for men to remain in the villages where they grew up, or nearby. There is some movement away from the parental village after the death of the man's father, but even then residence remains quite fixed. These data are misleading in one respect. Vugha is an area of traditionally dense population, and one in which it is difficult to purchase enough land to live on if one does not inherit land. When the men who were questioned were asked to list their sons, with places of residence, it became clear that some sons were moving away to areas where land was easier to acquire. 21% of the married sons (16 of 77) had settled outside their fathers' chiefdom.

Place of Birth of Married Men, as Related to Current Place of Residence	Number of Men
Same Village	67 (48.5%)
Different Village within Same Chiefdom	51 (37%)
Son of Vugha Man Who Was Then Living in Different Chiefdom	16 (11.5%)
Originating in Different Chiefdom	<u>4 (3%)</u>
	Total 138

Fig. 7 Residence of Married Men in 1968, as Related to Birthplace

Place in which Married Men spent Childhood, as Related to Current Place of Residence	Number of Men	Of Whom Those with Living Fathers
Same Village	91 (66%)	45 (82%)
Different Village within Same Chiefdom	41 (30%)	8 (14.5%)
Son of Vugha Man Who Was Then Living in Different Chiefdom	2 (1%)	2 ( 3.5%)
Originating in Different Chiefdom	<u>4 (3%)</u>	<u>0</u>
Total	138	55

Fig. 8 Residence of Married Men in 1968, as Related to Childhood Home

The final transfer of property to the sons takes place at the time of the father's death. Land and wealth are divided at that time, except for the portion which is kept as unallocated property (kifu; see p. 86 ) to use for the welfare of the entire group, or as the future property of minors who are too young to inherit. Land which has already been allotted to a matricentral house remains the property of that house, and the man's land is divided. Wealth, which unlike land had not been transferred from the father to his wives or their sons before his death (except for the sons' bridewealth), is divided after his death. There has been a very important change in the inheritance of property, from the late pre-colonial period to the present time. Formerly, wealth was divided so that each matricentral house received an equal portion. Under this system, individuals in a house which had many sons would receive much less per person than individuals in a small house. Today, wealth is divided equally among the sons. It is difficult to see exactly why this change took place. I can propose a number of possible solutions, but none of them seems completely satisfying. First, birth control was

practiced more rigorously in the pre-colonial period than it is now\*, which means that there may not have been any very large matricentral houses in those days. Second, the change may be related to the decline of kifu (unallocated wealth). In the pre-colonial period, unallocated wealth was often used for the initiation rites and bridewealth of the young men of the medial lineage. The most important expenses, then, were guaranteed for all members of the group, no matter how large or small their individual inheritances. Where kifu wealth and the division of property among houses coexisted, the largest and strongest house had the most to lose by the division of kifu, since the greatest amount per person would go to the weakest and smallest house. This would have given the older and larger houses an incentive to use the kifu wealth for the benefit of all the houses.<sup>2</sup>

Whether the inheritance was divided among houses, or among sons, the rights of minors were, and are, carefully protected. When determining the amount of land a minor will receive, his portion is made equal to the amount received by any of his full brothers not only at the time of their father's death, but also including land they received at marriage. When wealth is divided, a minor is supposed to receive an allowance for bride-wealth (which his older brothers may already have received) in addition to his equal portion.

---

\*There was a strict rule, in the late pre-colonial period, that a woman should not have a second child until the first could run by himself in time of war. Birth control was practiced through the rhythm method (based on the assumption that a woman was only fertile at about the time she was menstruating), through interrupted intercourse, and through the inducing of abortions by drinking infusions of herbs. All three methods are still used, but the rule about spacing between children has been relaxed considerably.

With the death of the father, and the disposition of the inheritance, further development and articulation is best treated as part of the analysis of descent groups, in chapter

### III

There is a supplementary form of alliance, among the Shambaa, mention of which has been too long delayed, for it is of major significance in village and neighbourhood integration. This is the blood pact.

The blood pact (mbuya or shogha, both singular and plural; the verb for is -shoghana) is a form of alliance which is made between two men, or two women, of lineages which may intermarry. In many conversations about the blood pact, Shambaa informants explicitly compared it to marriage, and maintained that it was associated with marriage. Karasek, in his ethnography, went so far as to speculate that marriage in former times had merely been a variety of the blood pact (1911: 186). When I asked why men do not make the blood pact with women, I was told by a number of informants that marriage is the blood pact. Both are forms of alliance between members of separate lineages. It is my purpose here merely to give a summary description of the blood pact. The way in which the two forms of alliance are used in combination will be discussed in the succeeding section.

In its most usual form, the two men who are making the pact go to some private place with a third man, the mtani, the joking partner or mediator, who is trusted by both. They sit on the ground, on a skin or a woven mat, facing one another, each with one leg under and one over his future comrade's. They clasp one another's shoulders. The mediator beats together two knives over the heads of the two men, and pronounces the

curse to each man in turn. After each phrase, the man who is addressed answers, hao, a term which has no known Shambaa meaning outside this context.

'You Shekumkai.'

'Hao.'

'You may stop into your partner's house when he is away, and ask for food.'

'Hao.'

'But if you touch his wife, may you die.'

'Hao.'

After the mediator has continued in this manner, beating the knives and stating all the usual conditions, the two men speak and make conditions of their own, which are appropriate to the particular situation. Then the mediator makes a small cut just below the sternum of each man, a spot called he moyo, 'at the heart.' He takes either two pieces of meat, or, more commonly, two halves of an oyster nut (nkungu, Telfaria pedata), smears each with the blood of one man and gives it to the other to eat. One informant explained to me that the nut or the meat represents the flesh of your partner's body, so that once you have eaten his flesh and his blood 'you are one body.'

If one violates the conditions of the curse, one is killed by the blood. Death as a result of violation of the blood pact is counted as a 'bad death' (see p. 74 ) in which the man takes his own life as surely

as if he hangs himself. The curse applies only to the two individuals, and never to two whole lineages.

The pact is a contractual relationship. This is explained in the maxim, shogha ikoma ndaghiye, 'the blood pact kills only according to the terms of the oath.' In the most common form of the pact, however, the mediator makes of series of conditions of such generality that a diffuse element is introduced. Each man is told that he must report any secret plot he overhears which is meant to harm his partner, that he may eat and sleep in his partner's house, that he must not steal from his partner or make sexual approaches to his partner's spouse. If one partner dies with no surviving relatives, the other is expected to care for his children.

The blood pact is a useful mechanism for integrating strangers into the neighbourhood, which has so many overlapping internal links that it might otherwise seem closed to an outsider. When the pact is made by a new settler, it provides him with reliable information about local personalities and conflicts, and also with a set of potential affines. Blood partnership was made in the late pre-colonial period, as it is today, by traders who need places to sleep, information, and security in strange villages. It is said that the only men who dared to trade in Maasai villages in the pre-colonial period were those who had Maasai blood partners.

Within one's own chiefdom, blood partners are hidden allies. In the pre-colonial period one's blood partner would bring the news that people were plotting against one at the chief's court. I observed a court case in 1968, in which some of my neighbours were involved; their

ownership of a piece of land was being challenged. The transactions in question had taken place fifty years before, and so witnesses were difficult to find. The older members of the challenged lineage remembered the transaction, but their testimony was not convincing, because they were litigants. Then other witnesses came forward. It was only several months later, after I had completed my census of the neighbourhood, that I learned that all the witnesses had been blood partners to members of the threatened lineage. This case illustrates the great value of the blood pact: no one quite knows who has made the pact with whom, since only the two partners and the mtani need to be present at the rite, and so the man who plots against you may inadvertently ask for the assistance of your partner. And a blood partner can present himself in court as a disinterested witness.

In moments of personal crisis, when one does not know whom to trust, one can always turn to a blood partner. I knew a man whose wife ran away, and who, in a state of the greatest emotional turmoil, turned immediately to his blood partner for help. In the days of warfare, blood partners accompanied one another in battle. If a woman needs to make an unexpected urgent trip, she can ask her blood partner to care for her children, and be certain that the children will be well cared for. If a woman gives her children into the care of a stranger, she fears zongo -- the sorcery used by women against one another's children.

Medicine men have the greatest number of blood partners. This is because a man is not trusted with knowledge of really dangerous magic unless he makes the blood pact with the medicine man. Also, someone who goes to a medicine man to get charms in order to harm you may well

blunder upon your own blood partner. I made the blood pact with a man who had been teaching me Shambaa medicine. For a week there had been an impasse: the man would not tell me how to cure conditions induced by sorcery, because one needs to be a master of the harmful magic in order to make counter-magic. There was a possibility I would denounce him as a sorcerer. For my part, I suspected that the man might take the goat which I was paying for the knowledge, and then invent nonsense charms to teach me. So we made the blood pact. In the curse, he said that if I told anyone he knew the charms, I would die. I said that if he falsified the charms, or hid a part of them from me, he would die. Because of the variability of the curse, we were able to continue my training with complete trust.

Because medicine men have many local comrades, any prudent man avoids buying harmful medicines near his home. A man who wishes to acquire sorcery charms goes to a distant medicine man. This means that although any practitioner must know harmful medicines to be competent, the local men are trusted, and it is considered likely that (except in cases of their own disputes) they will use their powers for the protection of their neighbours.

It is clear that there are some forms of the blood pact which existed in the early colonial period, which have since disappeared. Wohlrab (1918: 170) described a form in which a young child was given an older protector by his father. A group of young children would go to a stream with their protectors; the pairs would sit facing one another, dip their foreheads in mud, and press foreheads while the mediator pronounced the curse. They were sworn not to poison one another, not to abuse one

another's mothers, to care for one another's orphaned children, and to tell one another about livestock hidden in villages around Shambaai, so that if one died, the other had a complete record of the dead man's wealth, for his heirs. The mediator also said, 'Your partner's sister is your wife.'

#### IV

The pattern of marriages, in combination with the blood pact, and with communal rituals, had the effect of creating a tightly knit neighbourhood fabric. A neighbourhood is an area with a radius of about two miles around a given village. Two villages a mile apart, in other words, have overlapping neighbourhoods, their people consider one another neighbours, and yet each has some neighbours who are considered more distant (socially) by the other. There is no Shambaa word for neighbourhood, which is merely a rough designation for a limited area within which intense interaction takes place. It is probable that in the pre-colonial period of the kingdom, overlapping neighbourhoods were less significant, as social units, than they are today, because each chiefdom, or semi-autonomous sub-chiefdom, was no larger than a neighbourhood. The requirement that each localized lineage segment maintain a house at a royal town or village probably led the descent groups of the political unit to interact more frequently with one another than they did with nearby groups across political boundaries. Even today, with no rule requiring attendance, men who attend the same court house see one another frequently, although they may live at some distance from one another.

There are a number of communal activities in which recruitment is based on residence in a common neighbourhood. The most important of these

occasions, in pre-colonial times, were the rites of passage (mivigha, s. mvigha). It is not relevant in this context to describe the rites, even in an abbreviated manner. But it is important to note that a rite of passage is considered valid only if many neighbours, of several lineages, participate. If a person performs all the ritual acts, and learns all the secrets of the initiates, in the privacy of his own homestead, or in a gathering of only his agnates, he is still considered an uninitiated person. A kihii (pl. vihii) is a bit of esoteric knowledge which is learned at a rite of passage. The same word is used for the gift which a neighbour gives to 'the owner of the rite,' that is, the host. The two kinds of kihii are the indispensable elements in a rite. Each rite has its characteristic drum beat, so that neighbours on surrounding ridges can tell which rite is being performed, and can come if they wish. A German missionary, writing in the 1890's, described the rites as the outward expression of a united society formed by the entire people (LangHeinrich 1903: 245). Evidence has been presented elsewhere which shows that neighbours had joined together in rites of passage even before the kingdom came into existence in the eighteenth century (Feierman 1970: 83, 90, 208).

Neighbours also join one another to bury the dead. This duty is taken very seriously, and it is argued that if you do not help bury your neighbours, and make a small contribution to the costs of the mourning feast, no one will bury you. At Vugha these days there is a secretary at every funeral, recording in a notebook the names of all those who attend, and the amounts they contribute.

Sacrifice to the dead, like the mourning ceremonies, cannot be

conducted by a single lineage in isolation. A key part in sacrifice is played by the medicine man, who must be of a lineage with which the bereaved could marry. The mediator at the mourning ceremonies must also be an outsider.

Neighbours cooperate in innumerable productive activities. They join in communal farming parties (ngeimo), and are rewarded with a feast by the owner of the field. Women of a village, or of several adjoining villages, help one another to carry in the harvest. Neighbours in the pre-colonial period met at the court of the chief, and at markets which ran in four day cycles.

Within a neighbourhood a given lineage often develops multiple overlapping ties of alliance with one or more other lineages. These ties are created by blood partnership, together with multiple marriages. This form of alliance is especially remarkable in the Shambaa case because cross cousin marriage, which is in many societies the major form of lineage alliance, is strongly disapproved, and because young men and women are allowed to choose their mates on the basis of personal affection. The old men who run the affairs of a lineage do not arrange its alliances. Young people were free to choose from among appropriate mates even in the late pre-colonial and early colonial periods: this is not a recent development, although in those days a few rich fathers betrothed their infant children (and paid bridewealth during the children's infancy) (Dupré n.d.: 31a; Dahlgrün 1903: 219; Wohlrab 1918: 167; Karasek 1918-1922: 82). Today infant betrothal has virtually disappeared, and yet ties between lineages can be remarkably strong and multifaceted.

There are a number of factors which contribute towards the creation

of neighbourhood solidarity based on alliance. It has been shown above (p. 129 and chapter i) that Shambaa villages are regarded as permanent, and that at least some of the sons of almost any man tend to live in their father's village. Within this relatively stable population, the range of marriageable women is decreased by the exclusion of lineage companions, as a result of the notion that cross cousin marriage is improper, and also as a result of a strong preference for marrying neighbours.

A woman needs to visit her parents quite often to keep happy, and she returns to her parents' home to have her first child. If she argues with her husband, she goes home for a while to her parents. A woman returns to her father's household to visit relatives who are ill, to attend mourning ceremonies, or to farm for an aged parent. All the many trips between the woman's new home and her natal village are much easier if she married within her neighbourhood. According to an early missionary, if a young man came from a distant village to seek a wife, he was told that since the girls in his own neighbourhood clearly did not like him, no one would marry him as a mere stranger (Dupré n.d.: 30).

While there is no explicit rule, these days, that a woman must marry within her own neighbourhood, the overwhelming majority of marriages are still between neighbours, as seen in fig. 9. Of the 34 marriages in which the woman was living in 1968 in the village in which she had spent her childhood, only 11 (of a total of 251) were uxori-local marriages. In 23 marriages, the husband and wife were both living in the village in which they had been brought up.

## Number of Marriages

Same Village	34 (14%)
Different Village in Same Chiefdom	174 (69%)
Different Chiefdom	<u>43</u> (17%)
Total number of marriages	251

Fig. 9 Wife's Childhood Village as Related to Husband's Current Village

N.B. The villages in the census were at the centre of a chiefdom, so that for the purposes of this figure, the chiefdom and the neighbourhood were conterminous.

The ties of alliance develop fully when a number of marriages are made between members of two lineages. Men of each lineage are permitted to take wives from the other. Often these marriages are concentrated within a single medial lineage on each side. It is possible for the relationship to continue into the next generation, in spite of the disapproval of cross cousin marriage. If a man has two wives, one from lineage A, and one from lineage B, then the sons of mother A are free to marry women from B, and the sons of mother B are free to marry A women. The mother's co-wife's brother is not seen as a 'mother's brother' (mtumba), either in terms of bridewealth transfer, or in terms of relationship categories.

Marriage may be seen as both alliance, and in its more private aspect as the formation of an intimate household for child rearing and cohabitation. If a marriage is either preceded or followed by a blood pact between members of the two lineages, then the political aspect of marriage is emphasized, and the two groups are more firmly allied. The

existence of the blood pact increases the likelihood that a number of subsequent marriages will take place.

The development of multiple ties of alliance comes about when a succession of young people, faced by the need to choose a medial lineage from which to take a mate, all make the same decision. The quality of relations between the lineages affects the choice for several reasons. There is a tension between fathers and sons over how early the sons marry. If a father is happy with his son's choice of a wife he may consent to an early marriage. If the girl's father is happy with the potential marriage, he will put few obstacles in the young man's way.

Virtually all women, once married, run away to their parents at some time, after arguing with their husbands. If her parents value the ties created by her marriage, they are more likely to encourage her to return to her husband. With each successive marriage between the two lineages, the tie is valued more highly. One young wife I knew, whose marriage was the most recent of a long series of marriages between her own and her husband's lineage, left him after an argument and ran away to his father's house. This was a very effective strategy. She won sympathy by showing that she had no intention of breaking up the marriage. Her husband's father was blunt and effective in his criticism of his son. He said things a wife's father could never say to a daughter's husband.

Fig. 10 shows that multiple marriages are not the majority of Shambaa marriages. But when they occur they are extremely significant for local politics, and the alliances formed are repeated a number of times. There were only 17 instances of the blood pact alone linking marriage partners, while there were an additional 30 cases in which the

blood pact existed alongside a multiple marriage tie. The way in which the links pile up, and are reduplicated, is shown in Fig. 11, which is a diagram of the relationships between the descendants of SS and of SK, who took up residence in the same village in the first decade of the twentieth century, and who made the blood pact as soon as they became close neighbours. When multiple alliances are formed, they are usually, in the cases I have observed, a result of conscious intent. It seems likely that in the late pre-colonial period, with the existence of infant betrothal, lineage alliances were at least as important as they are today.

Existing Ties between Lineage of Husband and Wife	Number of Marriages with these ties
Multiple Marriage and/or Blood Partnership	71 (34.6%)
Of which:	
Multiple Marriage	54 (26.3%)
Blood Partnership	47 (22.9%)
Of which:	
Overlapping Blood Partnership and Multiple Marriage	30 (14.6%)
Cross Cousins	8 ( 3.9%)
None	<u>126 (61.5%)</u>
Total	205

Fig. 10 Existing Ties among Lineages of Husbands and Wives  
(Muslims and Pagans)

Generation

1

2

3

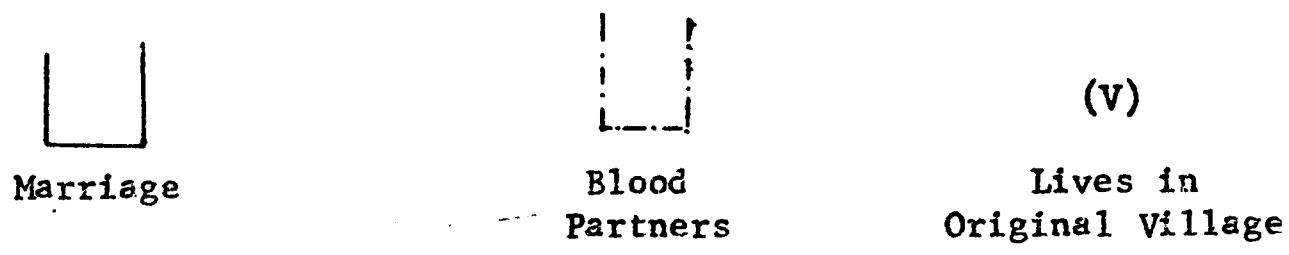
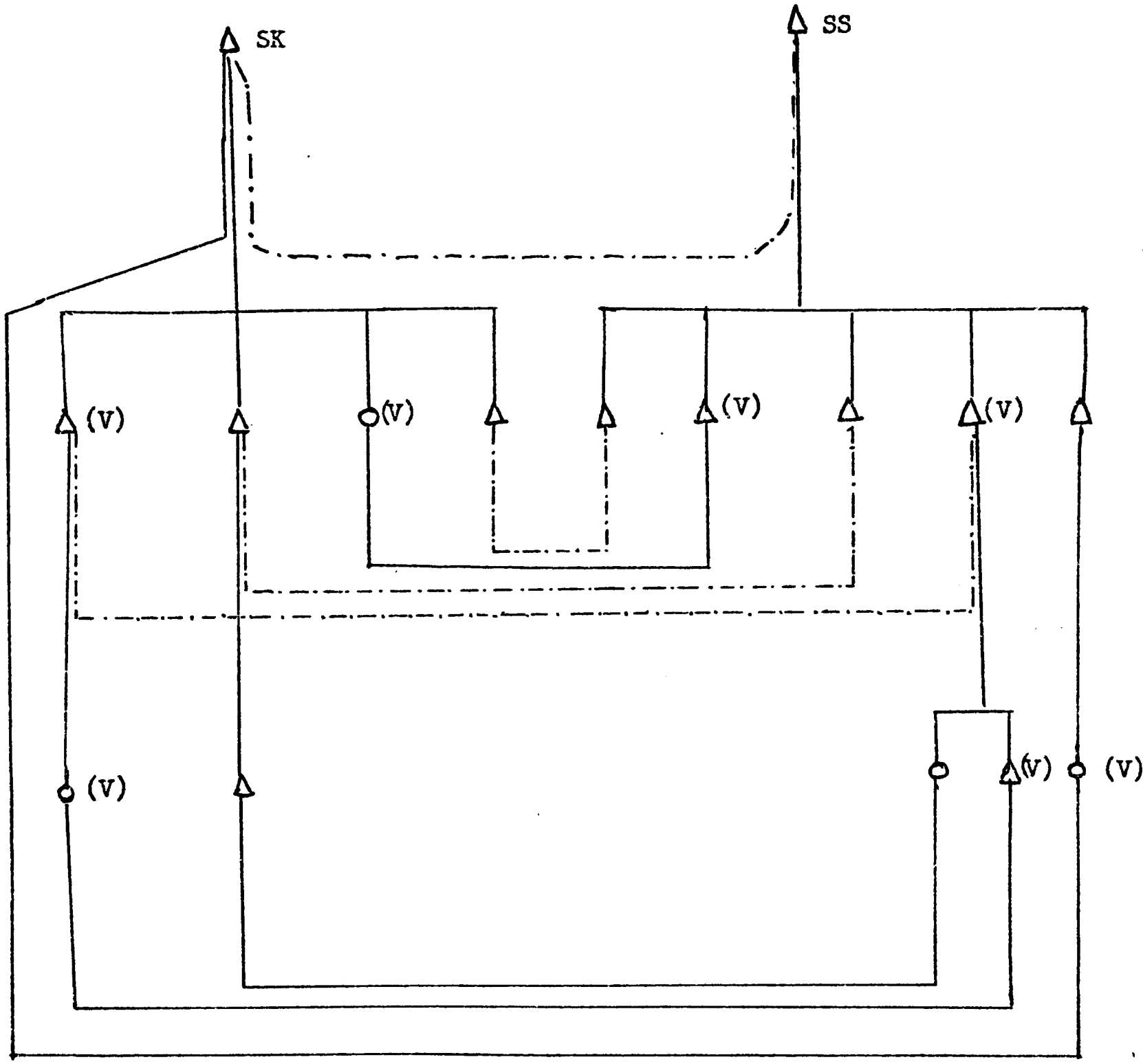

Fig. 11 Connexions between the Descendants of SK and of SS

N.B. SK's marriage to the woman of generation 3 is recent.

It is important to remember that the marriages between the descendants of SS and those of SK resulted from the free choice of the young people, as determined by both their views of their own self interest, and personal affection. The freedom given to the young people to choose within the neighbourhood, taken together with the marriage prohibitions, lead to a relatively wide distribution of the marriage ties of any medial lineage through the limited population of the neighbourhood. Concentrations of alliances, as between the segments of SK and SS, result from a series of judgments by individual young people that marriage with the allies is attractive. When seen in this light, the frequency of marriages between allied lineages is quite high, although not nearly as high as it would be if marriages were arranged.

Within any single village the ties of alliance are, as one would expect, more intense than they are in the neighbourhood as a whole. Most frequently the ties of alliance are greatly intensified once men of two lineages take up residence together. This can be seen from the data given in fig. 12 which indicate the relations between each man questioned and the senior men of his village. Affinity and the blood pact account for 45.9% of these relations, considerably more than the number of ties through common patrilineal descent. In the cases of alliance, marriage has come after co-residence, for uxori-local marriage is quite rare (see p. 140). Marriages with neighbours in one generation lead to the creation of ties through uterine links in the next, accounting for 13.9% of relations with senior men.

Relationships between Men Surveyed and the Senior Men of their Villages	Number of Ties of Relationship
Affinity and the Blood Pact	125 (45.9%)
Of which: Affinity without the blood pact	12 ( 4.4%)
The blood pact without affinity	46 (16.9%)
Blood pact and affinity together	67 (24.5%)
Common Patrilineal Descent	78 (28.6%)
Relationships through Uterine Links	38 (13.9%)
None	29 (10.6%)
Alliance Continued over Two Generations (Relations through uterine links to- gether with blood pact and affinity)	<u>2</u> ( 0.7%)
Total	272

Fig. 12 Responses to the Question: 'Who are the two or three men of your village senior enough to arbitrate disputes, and how are you related to them?'

In summary, intense local ties of alliance have come into existence in the absence of any preferential rule for the marriage of kinsmen, and in a situation where elders do not make marriage choices for young people. A proscriptive marriage rule based on the bridewealth payments is combined with a preference for marrying neighbours, and the desire of young people to make advantageous marriages; all these together, in a situation where individuals choose their own marriage partners, result in the network of alliances outlined above.

## FOOTNOTES - CHAPTER THREE

<sup>1</sup>These words were all used in the same way at the beginning of this century (LangHeinrich 1921).

<sup>2</sup>Wohlrab stated that daughters of a house were entitled to a share equal to that of the sons, but I have seen no other printed reference, and met no informant, in agreement with this statement (1918: 162).

## CHAPTER FOUR

### ROYAL DESCENT AND ALLIANCE

Descent and alliance among members of the royal Kilindi lineage, and alliance between Kilindi and commoners, were based on the same principles as descent and alliance among commoners, but the principles were put to different uses. The Kilindi position within Shambaa society was special because of the right of chiefs to appropriate the wealth of commoners, and because the most important heritable good was political office. This view of Kilindi organization as a mere variant of Shambaa descent structure is an outsider's summation. There is a general understanding among the Shambaa that Kilindi, who share Shambaa language and take Shambaa wives, arrange their family affairs in much the same way as commoners. Many Shambaa strongly disapprove, and even express revulsion at, Kilindi practices such as marriage without bridewealth, but it will be shown as the analysis progresses, that Shambaa attribute Kilindi practices, not to the strangeness of the royal lineage, but to its power. Commoners recognize that if they had the power, they would act in much the same way. And Kilindi who lose office are no different from Shambaa commoners.

There are two major topics of discussion in this chapter. The first, in sections i and ii, is a study of the rules and definitions of Kilindi descent and alliance, with an indication of the way in which political office was passed on through the descent structure, and of the uses to which chiefs put alliance. The second is a study of the cyclical process of the development of the Kilindi lineage. Office holders were related

to one another in different ways, and behaved towards one another in different ways, at separate stages of the lineage's development. It is impossible to describe power relations among King and chiefs except through a full description of the cycle, for power relations varied at separate points in this cycle. The structure of the kingdom can only be understood through a description of all the stages of development. It would be fallacious to describe one momentary configuration as order, and all others as aberrations, or periods of chaos.

## I

The crucial difference between political office, which was inherited within the royal lineage, and the land and livestock inherited within a subject lineage, is that land and livestock, as productive resources for subsistence, were best divided among potential heirs, where as political office could not be divided. After a commoner's land was divided equally among his sons, or among matricentral houses, those sons who did not have enough land to farm successfully moved off to areas where land was freely available. The King's land and livestock, however, belonged to the office. The King's land, and the land of subordinate chiefs, was kitaa, or court, land. Subjects were given plots to use in order to grow the food crops they would eat when at court (see p. 33). Other plots of court land were farmed by the subjects to provide food for the court itself. When a King died, all the kitaa land went to his successor. Similarly, the King's livestock, cloth, and guns, (as well as the regalia) went undivided to the successor, because the prestige of the King of Vugha depended, to a certain extent, on his wealth. In fact, the wealth of the King depended on his

political success, and not on the natural increase of his herds. It was said that all the wealth of the land was the King's to take (see p.345 ).

The essential point here is that it is extremely difficult to make a separation between the King's personal property and interests, and those of his office. There was a personalization of the office, or, put another way, the office was embodied in the King's person. This can be seen in some of the maxims concerning royal rule. Zumbe aiho ne kitaa, means, 'wherever the chief is, that is the capital.' Kubushwa ni kufa, means, 'to abdicate is to die,' or, more loosely, 'the King's only abdication is death.' Thus there was no need to separate personal and official property because the King could never retire with his wealth. The identity of person and office extended to a concern with the physical characteristics of the King. No disfigured person (kiema, or kilema, pl. viema) could become King. A kiema is a person with a skin wound which never heals, with a missing finger, toe, or eye, or with cleft palate. In fact, no kiema could enter the royal burial enclosure, or come into contact with some of the most important of the royal magical charms. The one separation which was made between the more personal aspect of the King's life and the more official aspect, was in the separation between the royal capital (kitaa), and the small villages (viambo, s. kiambo) in which he kept those wives with young children. But even then, the young children in the villages were future chiefs and sub-chiefs.

Since the purpose of royal inheritance was to bring about inequality among heirs, a division of office being equivalent to a dilution of power, there was a sharp separation between the great house (nyumba nkuu) and all the other matricentral houses of children of the King. It was expected

that the (senior) son of the great house (ng'wana nyumba nkuu) would ultimately inherit all the property of his father, and authority over the entire kingdom. Or, if this son was too young, a brother of the King could inherit. Only the wives of the dead King were not inherited by the royal heir, since, it will be remembered (p. 64 ) they could only be inherited by members of the dead husband's generation. They went, in a 'normal' succession, to the father's brothers of the new King.

Nyumba nkuu, which has been translated here as 'the great house,' can also be taken to mean 'the senior house,' since kuu (or kulu) means both large and old. This form of inheritance was not peculiar to the Kilindi lineage, nor did it originate with the Kilindi. In the days before the creation of the kingdom, the ritual leadership of some clans was inherited by the 'son of the great house' (see p. 53 ). There were some lineages in which a particular kind of witchcraft practice (ushai wa kukitima -- a kind of inverted sacrificial rite) was handed on from generation to generation. In these cases it was the eldest son of the witch's senior wife who continued the practice.

In ordinary households, the 'great wife,' or 'the senior wife' (mvyee mkuu, or mvyele mkulu), is the first wife a man marries, whether or not she is the oldest. She has no special rights to property, but she does have a position of respect. One man I knew quite well said to me, 'Your first wife has seen your nakedness and your shame. If a man does not live in harmony with his first wife, he will not succeed in anything he does.' A medicine man keeps the most important of those gourds and charms which may be kept in the homestead in the house of his senior wife. According to a missionary writing in the 1890's, it was the senior wife

who organized working parties of a man's wives on his 'masculine gardens' (LangHeinrich 1903: 223).

A new King chose his great wife at the time of his accession. The great wife bore the heir on the skin of a lion said to have been killed by Mbegha, the herioc hunter and first King.\* The King could help to ensure the succession of the son of the great wife by entrusting some of his most important magical charms to his great wife, who would be sure to support her son in a succession dispute. The King, when keeping his charms in the great house (described on p. 290) was behaving in the same way as an ordinary medicine man keeping charms in the house of his senior wife. In the end, however, it was the officials of the royal capital, who were men of subject lineages, who decided on the heir to the throne, sometimes passing by the son of the great wife. (The officials of Vugha are discussed in chapter vi.) The most important of the rain charms was a part removed from the body of the King after his death, and given to the great wife for her son. Whatever his position in terms of descent, a man became King only by going through the rite of accession, which is described in detail in chapter v. It was impossible for two men to go through the entire rite.

The new King, in making provisions for his own children, gave a chiefdom, and nothing more, to each matrilineal house. The political offices of the chiefdom provided the members of the matrilineal house with all their needs. All the livestock owned by the commoners was seen

---

\*It is not clear what happened if a girl was born on the lion's skin. Abdallah bin Hemedi 'lAjemy wrote that if the first child of the Great Wife was a girl, the infant was killed.

as belonging, in a residual sense, to the chief and sub-chiefs, who could collect any wealth they needed as tribute. There were official gardens belonging to each chief's or sub-chief's position, and it was the duty of subjects to till the land of those who governed them. The wife to whom the chiefdom was being allocated went along with her children, and if they were young, her brother went as well. Most frequently, the eldest son of the matri-segment was chief, and his younger siblings were sub-chiefs who administered portions of the chiefdom. The great house was given the chiefdom of Bumbuli, while the King himself governed Vugha.

In a commoner lineage, allocation of a piece of property to a matri-central house determined the ultimate path of the inheritance of that property. Allocation was merely the first step towards permanent transfer. The most difficult political problems associated with the transfer of office through the life cycle of successive Kings arose from the expectation that the possession of a chiefdom would be terminated, rather than made permanent, with the death of the father who allocated it. This was the way in which the scarcity of office was maintained. The new King, in order to make his sons chiefs, needed to remove the former chiefs, his brothers, from their positions. The political conflict engendered by this is discussed below, in parts iii and iv of this chapter.

Once an individual had been removed from office, or had failed to gain an office, he was recognized as a Kilindi during his lifetime, but his descendants were no longer members of the Kilindi lineage. They often adopted other lineage names after one or two generations. When it is remembered that they originated as Kilindi, they are called Wakiindi wa kaya, 'Kilindi of the common homestead.' As soon as a man gave up

chiefship, he had to struggle to see that the wealth of his minimal or medial lineage was adequate for survival in famine, and for the payment of possible indemnities. A Kilindi of the common homestead retained none of the prestige of his former position. I met one such man, the grandson of a chief, who had not learned that his forebears had been Kilindi until the time of his puberty rites.

It will be remembered that an ordinary lineage, when it becomes too large, splits into two groups of collaterals, roughly equal in size. The process occurs when, after the division of available land, some lineage members move away to a place where land is more plentiful, and the spatially separate groups ultimately become separate maximal lineages. The Kilindi, by contrast, tended to shed individuals, not ramified groups, and they did so on a generational basis. Sons of a dead King (and their descendants) were removed in order to make positions available for sons of a living King. In operational terms, then, the Kilindi lineage was defined as a lineage the members of which could live off political office, and which used special forms of descent and alliance appropriate to office. As soon as excess Kilindi were forced to support themselves in the ordinary way, they ceased to think of themselves as Kilindi, and they ceased to practice Kilindi descent and alliance. It is hard to see any other way the Kilindi could have maintained themselves as a small ruling group, given the propensity of chiefs to extravagant polygyny.

It was possible for failed successors to leave the kingdom altogether, to set up rival kingdoms or chiefdoms, thus splitting the Kilindi lineage in a way more closely analogous to the fission of commoner lineages. Although one of these rival polities (Mshihwi) survived for a full century,

such territories are initially looked upon, by Kilindi of Vugha, as temporary aberrations, annoyances to be eliminated.

The unique Kilindi practice of shedding lineage members resulted in the development of a genealogy which is quite different in form from the genealogies of commoner lineages. A wide range of collaterals are remembered for the descendants of the most recent King who successfully gave the chiefdoms to his sons (Kimweri ye Nyumbai). For the period before Kimweri ye Nyumbai, one individual -- the King -- is remembered in each generation, because the collaterals in those generations are no longer relevant for the political arrangements which survived up to the time of Tanzanian independence. In fact there is one King -- the brother of Bughe, in the second generation of the kingdom's existence -- whose name is omitted from virtually all the genealogies because his descendants did not remain Kilindi. He is remembered only because it is the job of some court officials to remember all the graves at the royal burial enclosure, in which he was buried. A commoner genealogy, by contrast, includes many collaterals for three generations, and then the name of a single ancestor in the more distant past.

In an ordinary lineage, the influence of an ancestor over the welfare of the living continues only as long as a patrimony survives which is identifiably his. In other words, he retains some control over his wealth and his children, even though he is dead. After two generations during which the wealth has been redivided among heirs, it is no longer necessary to think of the wealth as his, and therefore the living no longer think of him as influential. We have seen that in the Kilindi lineage, on the other hand, the patrimony was never divided. The kingdom of the early Kings was

passed on whole to the living. For this reason, the early ancestors retain their influence over the welfare of those who survive.

In addition, the entire kingdom is the patrimony over which those ancestors have influence, and so the propitiation of the ancestors is a public act with implications for the welfare of all citizens of the kingdom, Kilindi and commoners alike. There are two distinct kinds of sacrificial rites performed by the Kilindi. First, there are the rites for a man who has died recently, performed by the man's children. These rites are essentially the same as sacrificial rites performed by commoners (see p. 68 ). In addition, there were periodic rites for the welfare of the kingdom: for the fertility of the land, and for success in war. At these rites the King alone, of all Kilindi, was present, together with the commoner officials of the court. The ancestors were invoked, and were offered a sacrifice, because the magic being used had first been theirs, and the kingdom had been theirs. The King alone mediated between the kingdom and the ancestors. Each chief performed similar rites for his own chiefdom, mediating between the chiefdom and the royal ancestors.

## II

We have seen that, in terms of descent, the Shambaa kingdom comprised a great number of commoner lineages, most of them localized in a few villages within a single chiefdom, with a single governing lineage floating over them all, spread through the territory of the entire kingdom. Picturing the Kilindi and the commoners in this way, as two distinct levels of a hierarchy, it still remains to determine what was it that tied

together the two levels, joining them as constituent parts of a coherent and vertically unified kingdom? There are two parts to the answer to this question. First, to be discussed in this section, there were transitory alliances, by marriage and the blood pact, between individual Kilindi and particular commoner lineages. These alliances could, by their nature, be adapted to changing local circumstances: to the rise of one lineage and the decline of another, to the need of a King for allies in a particular chiefdom. But these alliances were important only in defining the relationship between particular Kilindi and particular commoners, and a great many commoner lineages were without such alliances. Second, the more general relationship between the two levels of the hierarchy was defined in terms of the symbols of kingship and chiefship, and the conceptions of the effects of political action on rain, crop pests, the general level of violence in society. The entire second half of this thesis, and especially chapter viii, will be devoted to conceptions of the relationship between politics, cosmology, and the general welfare of the Shambaa. I am mentioning this very large problem here, in order to set the study of Kilindi alliance into its proper context. The ideas associated with kinship -- with marriage, the blood pact, and uterine ties -- joined the two levels of the hierarchy in a way that was crucial for the outcome of particular situations of conflict or competition: for drawing dissident but powerful lineages into cooperation with Kilindi, and for giving some Kilindi factions preeminence. But the ideology of kinship was applied locally, and was not a general set of conceptions for inter-hierarchical relations.

One of the most important alliances a King made was with the lineage

of his great wife, chosen at the time of accession. The great wife was usually from the chiefdom of Bumbuli, so that when the son of the great house was sent there as chief, he would be supported, and educated, by the lineage of his mother's brothers. The lineage in question would be certain to support the new King (their woman's husband) in any conflicts he might have with the Kilindi chiefs because they knew that some day they would hold positions of great prestige as mother's brothers to the King. The alliance with the lineage which provided the great wife appears to have been most important in the late eighteenth century, in the period when the Nango clan was resisting Kilindi rule. After internecine Nango disputes led to the death of the Nango ritual leader, the King (Bughe) took his great wife from one of the leading Nango sub-clans, and so split the Nango permanently, and reduced their independent power. The descent group which provided the great wife traded off the possibility of exercising power independently in return for a prominent place in the life of the kingdom. At the time of succession, the mothers' brothers of the potential heirs were crucial allies of their sisters' sons. In the case of the Nango, when Bughe died, and the elders of Vugha were deciding on a successor (the process is described on pp.195-207 and p. 231 ), the lineage of Bughe's great wife came to Vugha at a crucial moment, in support of their sister's son.

The King most likely to be successful at removing his half-brothers from their positions as chiefs, and giving the chiefdoms to his sons, was one who had made alliances with the important subject lineages of each chiefdom before he acceded to the throne, so that he could send his sons to govern the lands of their mothers' brothers. Quite often a very young

chief was sent out to govern under the regency of his mother's brother or mother's father. In these cases the practical effect was to leave control of the affairs of a chiefdom in the hands of a member of a prominent subject lineage of that chiefdom. The young chief, as he grew to maturity, would take wives from the other important subject lineages, thus strengthening his position, and making it more difficult for his father's successor as King to remove him and install a new young chief.

Not all Kilindi marriages were carefully thought out political alliances. Men who could take wives at will were not unaware of the pleasures of the flesh. Commoners at the court, who wished to win the King's (or chief's) good will, brought beautiful young women to his attention. If the King (or a chief) found a slave girl especially attractive, or if he made her pregnant, he could raise her to the status of 'chief's wife' (mke zumbe), and her former position of slavery would be forgotten. It is said that some Kings even took the wives of their subjects, and that commoners with attractive wives hid them away in obscure villages.

As with wealth, so with wives; there was virtually no separation between a chief's official interests and his personal interests. Attempted adultery with a King's wife was an act of rebellion punished by death. The figure of speech for the King's unchallenged dominance was that he was a man, and the commoners or the other Kilindi were women. In many of the traditions describing how the commoners of a territory went to the King to request that they be given a chief, the commoners came before the King and said, Ti wayyee du, 'We are only women,' meaning that there was no preeminent political leader. A challenge to the King's masculinity was indeed an affair of state.

Marriage was supplemented by the blood pact as a form of Kilindi-commoner alliance. The two were seen as complementary means of achieving a single purpose. It was possible for a Kilindi to place a bracelet which was a single link of a chain before a pregnant woman whose husband was a member of a lineage with which the Kilindi wished to make an alliance. If the woman bore a daughter, the infant was betrothed to the Kilindi. If the woman bore a son, the alliance took the form of the blood pact.

There were several important differences between the political uses and effects of marriage and of the blood pact. The first, so obvious it hardly needs saying, is that with marriage the relationship was continued in the succeeding generation as one of mother's brother to sister's son. Also, the blood pact enabled Kilindi who could not marry one another to form alliances. There were, for example, a great many matrilineal houses of the children of Kimweri ye Nyumbai. Members of these houses could not marry one another, and yet factions comprising groups of houses formed, and opposed one another. A blood pact between one member of each of two houses made the alliance between those houses more permanent, and created a fixed point in the shifting patterns of faction.

It was the relative fixity of the blood pact, for at least the lifetimes of the two blood partners, which was the greatest disadvantage of this form of chiefly alliance. In pre-colonial Shambaa politics, as in the modern politics of international relations, alliances which seemed permanent and immutable at the time they were made, could be subject to dramatic shifts. The death of Kimweri Maguvu (who was King from about 1870 to 1893) is attributed to the shift in his relations with the Maasai. Early in his career Kimweri made the blood pact with a Maasai (or possibly

Iloikop) leader who is remembered in Shambaai as Lemnga, or Elemunga. When the German presence in the Pangani Valley began to grow, Kimweri was able to achieve a temporarily satisfactory relationship with the Germans at the expense of the Maasai. According to one tradition, as told by a Kilindi of Vugha, Kimweri heard of a plot for the murder of Lemnga by some Shambaa, in order to dissolve the embarrassing alliance permanently. He did not tell his blood partner, and soon after the death of Lemnga, Kimweri died.

In relations between Kilindi and important political leaders outside Shambaai, marriage and the blood pact were sometimes combined. Semboja, the late nineteenth century trading chief, made the blood pact with a Zigula chief, and married the chief's sister. He gave his daughter as wife to another Zigula chief, and made the blood pact with a number of influential traders and chiefs throughout the Pangani Valley region (Feierman 1970: 183-184).

\* \* \* \* \*

Most Kilindi women did not marry aliens. They took husbands from among the Shambaa men of ordinary lineages, thus giving men of ordinary lineages adjunct status among the Kilindi. The husbands of Kilindi women were minor functionaries, completely loyal to the matricentral houses into which they married, for they had no authority except for that conferred on them by the brother of their wives. These husbands were incapable of developing independent, stable sources of support, because they lacked the legitimacy of Kilindi descent.

Many of the husbands of Kilindi women became wakai wa nkondo, 'fierce

ones of war', who lived at the capital of the King or a chief, and who led the Shambaa armies in war. (For a full discussion of Shambaa warfare, see chapter vii .) An mkai wa nkondo would be given a gun and several cloths in the latest style (in the late nineteenth century), as well as an iron bush knife. All of these were extremely rare and expensive in pre-colonial Shambaa, and must have been a source of pride to their possessor. The fierce men of war received the perquisites of official court residents: food from the chief's gardens, meat from the livestock killed at court, and some of the wealth collected casually by court hangers-on as tribute. In addition, each prominent fighter received a share of the booty taken in war.

In cases where a daughter of the King was the oldest member of a matrilineal house, she was made chief until the oldest of her brothers matured. In many cases women served permanently as sub-chiefs. When this happened, the woman attended partly to affairs of government, and partly to cooking and child rearing. For the most part, a woman chief's husband would judge disputes, and take care of the day to day management of political affairs. He would split the profits of chiefship with his wife. The recruitment of chiefs through marriage to Kilindi women did not end with colonial conquest. In the period after World War II, the chiefdom which included the royal capital (Vugha) was administered by a subordinate chief, and not, as in the pre-colonial period, by the King himself. This administrative arrangement created a political problem, for the men of Vugha insisted that the King be the only Kilindi at or near the capital, because it is too easy for a competing Kilindi living at Vugha to plot against the King. The solution of the members of the

court was to appoint a commoner who had married a daughter of the King. The chief was extremely loyal because he owed his position to the King's wish, and he could be removed in a moment with no repercussions in Kilindi lineage politics.

In normal Shambaa marriages the woman was partially integrated into her husband's lineage, although she did not sever her ties to her natal patrilineage. In the marriage of a Shambaa man to a Kilindi woman, the pattern was reversed. The man kept his own lineage lands, but tended to live off the wealth of his wife's lineage (that is, off political office). Just as the senior wife of a commoner took a name belonging to her husband's lineage, the husband of a Kilindi woman took a Kilindi lineage name. Kilindi names are arranged in two generation sets, as in fig. 12A. In one sense, all the names in a generation set are equivalent, so that an individual commonly known as Shemkai might be addressed as Shemlughu. But there is a rough sense of the relative importance, or prestige, of different names, so that, at Vugha, Shekulwavu or Shebughe was usually reserved to the King, and subordinate chiefs were addressed by other Kilindi names. (Local practice varies. In Mshihwi a single small village will have a number of Shekulwavus. This was a source of some embarrassment to me. I lived first at Mshihwi, was given the name of Shekulwavu, and then moved to Vugha, where it appeared as though I had considerable pretensions.) The husbands of Kilindi women were given only the least prestigious of the lineage names: Shemlughu, Shekumlughu. People often say that the names beginning with the prefix 'O' are given to the wives of Kilindi, and 'Ma' to their daughters. Thus Mlughu marries Omlughu and has a daughter Mamlughu. But in fact this is not strictly followed: I have

## SHEKULWAVU GENERATION

## SHEBUGHE GENERATION

<u>Male</u>	<u>Female</u>	<u>Male</u>	<u>Female</u>
Kimweri	Okimea	Mnkande	Makihiyo
Mtoi	Omtoi	Mbegha	Omlughu
Shemlughu	Oshimba	Shekumkai	Om kai
Shemkai	Mamlughu	Mlughu	Ogao
Bughe	Mamnkande	Ng'wa Mtoi	Omlughu
Ng'wa Mbegha		Shekimweri	Okinyashi
Ng'wa Paua		Hoza (husbands of Kilindi women only)	Omnkande
Kihiyo		Shekumlughu	

Fig. 12A. Kilindi Lineage Names, by Generation

N.B. The prefix 'she' usually means 'father of', and 'ma' 'mother of.' Thus Shekimweri is in one generation, Kimweri in the next. But while there is a Shekulwavu, there is no name 'Kulwavu'; there is a Shekumkai, but no 'Kumkai.'

known wives of Kilindi with 'Ma' names, and daughters with 'O' names. In a commoner lineage many individuals are known by names from their mothers' lineages. Kilindi names were much more pervasive because of their connotations of power, among the men of the lineage, the women (who did not take names of their husbands' lineages), the daughters, and the daughters' husbands.

It is not only in the taking of lineage names that the Kilindi women acted out what was normally the man's role. It is recognized that Kilindi women were like men. Often the phrase is used, in describing this, wazaghauka waghoshi, 'they became men.' Kilindi women went through gao, the young men's initiation, before they married. They chose their husbands, while normally it was men who chose wives. The word for the act of marrying is -ghua, 'to take.' In normal usage, a man takes a wife (-ghua), and a woman is taken as wife (-ghuighwa, passive form). Kilindi women, however, 'took' husbands. Some men say (it is hard to tell whether

in jest) that while in normal sexual relations the man is on top, when a Kilindi woman took a Shambaa husband, the woman would be on top.

Given the equivalency, in Shambaa discourse, between masculinity and strength or superiority, to say that in these marriages the woman became the man is to say that the inequality of power which was normal in husband-wife relations was reversed. The man normally lies on his partner in sex because he is thought superior, she inferior. The inequality of power in Shambaa marriage is striking. If a woman feels herself abused, and if her brothers will not take action on her behalf, her only recourse is to commit suicide by the cooking pot (see p. 74 ). A woman chooses between doing as she is told and destroying herself. (There are, of course, in addition, subtle forms of domestic guerrilla warfare.) In marriages between Kilindi women and men of commoner lineages, the power imbalance was reversed. If a Kilindi woman died in childbirth (considered a sure sign of cooking pot suicide), her husband was killed.\* The justification was that 'the woman had been killed by his poisoned arrow.' The risks to a man of marriage to Kilindi women, because of both the punishment for cooking pot suicide and the dangers of being a leader in war, led Shambaa men of commoner lineages to employ magical charms for making themselves unattractive to the daughters of chiefs.

\* \* \* \* \*

When a chief married a commoner, or when his daughter married a man

---

\*When an ordinary woman died in childbirth it was considered her husband's fault. According to LangHeinrich, the man in such a case had to pay an indemnity of two cows to the woman's lineage (1903: 231).

from a commoner lineage, no usona was paid -- none of the payments were made which were customary before marriage as compensation for sexual rights to the woman, rights in the woman's labour, or rights to pay after the marriage for the filiation of future children. A chief could choose voluntarily to pay one or two goats before marriage, but the choice was his (LangHeinrich 1903: 243). When a chief's daughter chose a husband, the chief could voluntarily give the man a cloth, or some other object of wealth. Ukwe, the payment made after the birth of a child for the filiation of that child and future children, was customarily paid.

In the myth about the kingdom's origins, Mbegha, the hunter-hero, is driven out of his home in Ngulu, to the south of Shambaai, because of his dangerous character. In some of the versions, he flees in fear of being killed by the men with whose wives he has committed adultery. When he arrives in Shambaai he gives everyone meat, clears the land of a plague of wild pigs, impresses the Shambaa with his ability to mediate disputes, and so they make him their King. They are delighted to give him wives without asking for bridewealth. The most important of these wives bears a son named Bughe, which means 'adultery.' Bughe becomes the second King, perpetuating the political arrangements created by Mbegha. Some Shambaa, when discussing this aetiological tale, say that the people of Shambaai were delighted to give wives to Mbegha, but that his successors resembled Mbegha in his early years, when he took other men's wives by force.

There is thus an ambivalence in the attitude of the Shambaa toward the chief's right to take women without paying bridewealth. All the wealth of the land is the King's (or chief's) to take at will. There is a proverb, Ng'wana nyumba nkuu ni unde ja mpaas, hagheekwa. Literally translated, this

means, 'The son of the great house is a portion of impala meat, he cannot be added to.' This proverb refers to a hunter's behaviour in the market place. When people buy produce at a market they agree on a price and a quantity, and then, when the bargain has ostensibly been concluded, the purchaser says, 'Add just a bit, please.' The hunter who has impala meat to sell, however, divides the animal into equal portions, and there are no small bits to add after the conclusion of the bargain. The proverb is generally interpreted to mean that just as a hunter cannot add to the portions of impala meat, a commoner cannot bribe the chief, for everything in the land is the chief's. The chief does not pay bridewealth because all the wealth of the subject belongs to the chief.

To take a wife, however, from someone to whom bridewealth cannot be paid, is a violation of exogamy. It is turning in upon one's own wealth. Indeed, in one of the variants of the aetiological tale of Mbegha's sexuality, Mbegha is driven out of Ngulu after he has made his sister pregnant. The incestuous couple arrives in Shambaai, and Mbegha is made King.

It is clear that while, according to the theory of Shambaa chiefship, all the wealth was the chief's, in practice the commoners resented the loss of their daughters without bridewealth compensation, and they speak of the chiefs having taken wives 'by force' (kwa nguvu). This form of marriage was, then, an expression of the unequal ability of Kilindi and commoners to use force. The maternal grandmother of a good friend of mine in Mshihwi had been married in the 1890's to chief Shatu. After German conquest, the woman's brothers took her from Shatu's village, and arranged her marriage to another man, who paid them bridewealth. According to her

grandson, the Kilindi complained, but her kinsmen replied, 'You did not pay. You took her by force, and now your ability to use force has ended.'

It was the inequality of power in Kilindi-commoner marriages which made it inappropriate for a Kilindi to court a woman, as a commoner would. A chief who wished to marry a woman, or a chief's daughter who wished to marry a man, simply sent court officials to bring the intended spouse. In this, as in all matters of special Kilindi privilege, descent was not nearly so important as office. The King and the major chiefs could take wives without paying, whereas unofficial Kilindi -- Kilindi of the common homestead -- paid bridewealth in the same way as any commoner.

Since all the wealth of the land belonged to the chief, and since any chiefly marriage violated the rule of exogamy as defined by ownership of wealth, the rule determining permissible marriages among Kilindi could not be the same as the commoners' marriage rule described in chapter iii. LangHeinrich was told in 1896 that no marriages between Kilindi were permitted. My own informants, distributed over a wide area and many Kilindi sub-groups, insisted that marriage among Kilindi was permitted in the past, as it clearly is today. The rule, as currently stated, is that two Kilindi may marry if they have a common great-grandfather, but not if they have a common grandfather. In addition, Kilindi of the Shebughe generation may not marry one of the Shekulwavu generation. This is of some interest as a complement to the rule of exogamy as defined by the sharing of rights in wealth, for it shows the degree of relationship within which it would be improper for marriageable individuals to consider themselves members of separate lineages, whatever the formal arrangements in terms of wealth and sacrifice. It is probable that the same rule existed

in the 1890's, but that it was still thought improper for descendants of Kimweri ye Nyumbai to marry. Kimweri had died in 1862, and during his lifetime he had removed all previous Kilindi as chiefs. During the 1890's, then, Kimweri's sons were still alive, and there were no Kilindi within the Kingdom who were not Kimweri's descendants (as there are none today).

One question remains: if all the wealth of the land belonged to the King and chiefs, and if the Kilindi were powerful enough to take wives without paying bridewealth, why then did the chiefs pay ukwe, the cow for the filiation of children? I find this a very difficult question, one I never heard discussed in this form by Shambaa. Those who discussed ukwe simply said that if the cow had not been paid, the children would not have belonged to the Kilindi lineage. While the notion that all the wealth of the land belonged to the King is important and frequently discussed, there is no corresponding idea that the people belonged to the King. Each individual belonged to a lineage, and could not be taken as a slave by the King unless the individual's lineage drove him out, or a member of the lineage committed an offense against the state, or unless the lineage was unable to pay an indemnity. Wealth could establish the lineage membership of an individual, as with ukwe, or with the payment of an indemnity, but the King's right to the wealth of the land was not a right to the people of the land. This brings us full circle to the chiefly marriage without wealth. The chief did not acquire the woman, for she remained a member of her natal patrilineage. Only her services and potential fertility were transferred. The chief could mobilize services; he could take a substantial share of those scarce resources for which wealth was exchanged -- in this case, rights in marriageable women; but he could not, in a random

way, take people from lineages and join them to his own. The bridewealth paid before marriage was a rationing device, and the King held all the coupons, while the ukwe payment had no rationing function, but was a symbolic payment for the filiation of children. I must emphasize that this is my own interpretation, and not one presented to me in this form by Shambaa informants.

### III

When Shambaa describe the quality of political life at any given time, they specify whether the relationship between the King and the chiefs was one of domination or of competition. The same pair of categories provides a framework for the folk analysis of relations among contemporary political leaders at the local or national level. The assumptions underlying indigenous descriptions of royal politics are that domination on the one hand, and competition on the other, have two separate and quite specific sets of consequences for patterns of administration, and for the relative productiveness of the land. It is assumed by Shambaa that when the King dominated the chiefs, the land was fertile, tribute flowed to the royal capital, commoners could appeal the judgments of their chiefs at the court of the King, and only the King could impose the death penalty. When the King competed with the chiefs, there was drought and famine, tribute did not flow to the King's town, commoners could not appeal the judgments of their chiefs, and each chief could impose the death penalty. The Shambaa terms for domination and competition are catchwords which mark the existence of two configurations of relationships within the Kilindi lineage. This is the reason for mentioning here the dichotomy which will be discus-

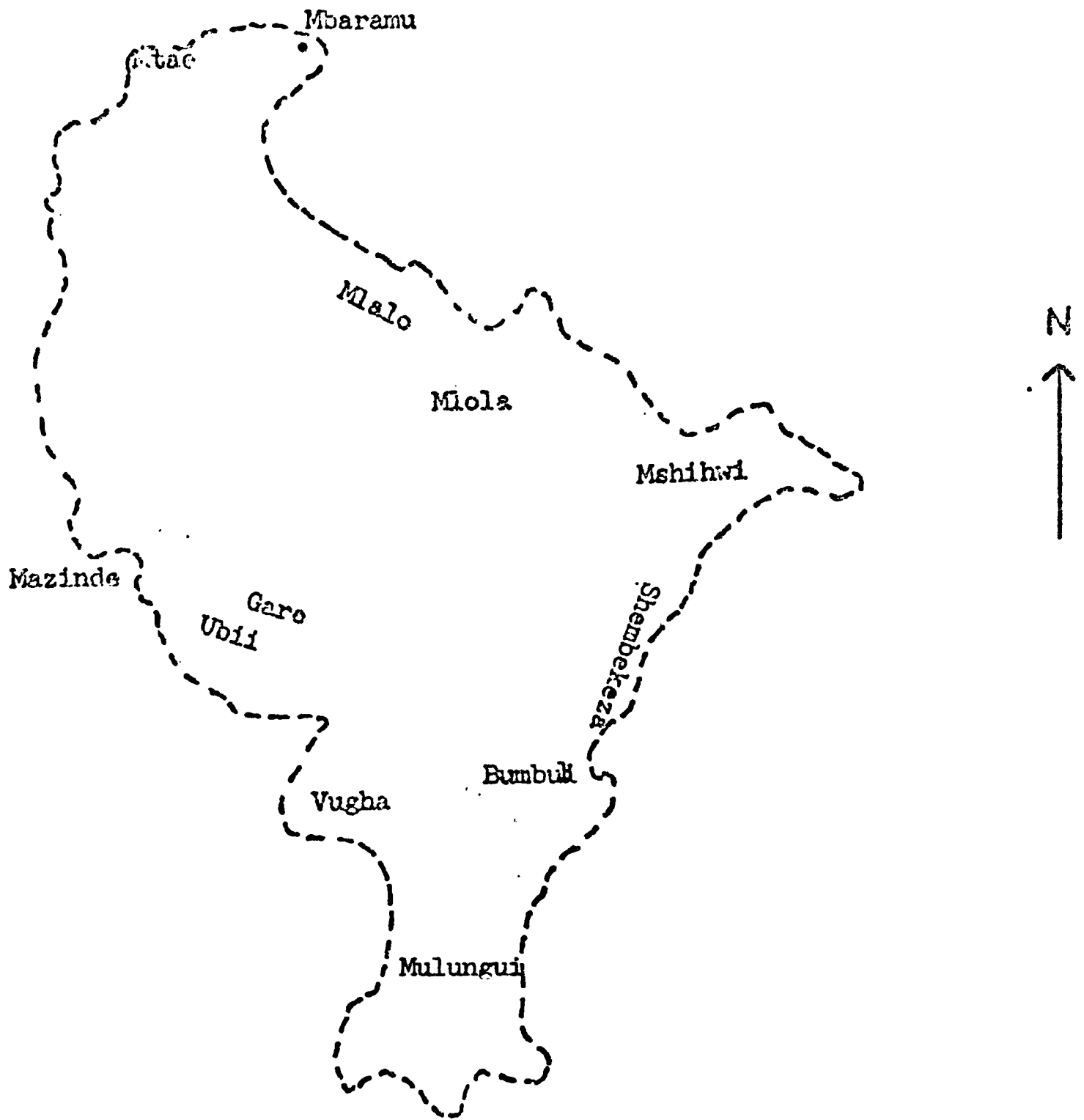

Sketch Map (after Mbazira)  
of the Major Chiefdoms  
of Shambaai (from Feierman 1970)

----- Escarpment

sed in detail in chapter vii, which is about patterns of administration, and chapter viii, about conceptions of the relationship between politics and the natural world.

In the descent configuration associated with royal domination, each chiefdom was governed by a matricentral house of the sons and daughters of the King. In this configuration, the expectations of behaviour associated with the descent positions of the King and chiefs reinforced the expectations associated with their political offices. The King's authority to issue commands to a chief was also the authority of a father over his son. In the configuration associated with competition, the chiefs were usually the King's half-brothers (although they could also be his father's brothers, or father's brothers' sons). In these cases the equality expected among men of a single generation conflicted with expectations that a King would dominate his chiefs.

Quite clearly, every King, in the period after his accession, attempted to remove his brothers as chiefs, and replace them with his sons. Equally clearly, every chief was bound to strive for the retention of control. The crucial question for an understanding of descent and alliance in the political process is, why did some Kings succeed in this enterprise while others did not? What elements in the statecraft of individual sovereigns, or in their positions in the descent structure, enabled them to dominate? In order to answer these questions I propose to examine, in this section and the next, the politics of descent and alliance in the careers of two successive Kings: Kimweri ye Nyumbai and Shekulwavu. The first dominated all the chiefs. The second competed with his chiefs and was ultimately

killed by them.\* It should be possible, after assuming that the basic characteristics of the Kilindi descent structure remained relatively constant over the two reigns, to isolate some of the variable elements, in the situations of the two Kings, which were associated with the success of the first and the failure of the second. The analysis of the careers of the two Kings as a single case, to be examined in detail, will make it possible to arrive at generalizations which are somewhat more carefully controlled than one could present through impressionistic explication, supplemented by apt illustration. Even an analysis of a single case, however, involves abstraction. The case was chosen from among many possible ones, and the details were selected to shed light on a chosen area of concern. The focusing concern is the indigenous conception that there is a single pair of alternative patterns of royal rule. The passage of time from the events described to the time of ethnographic research is a further selective mechanism, for only some details have survived, and not necessarily all those most central to this study.

Kimweri ye Nyumbai acceded no later than 1820, and quite probably before 1815 (Feierman 1970: 211). Kimweri's father, Kinyashi Muanga Ike, had failed to take control of some of the most important chiefdoms of southern Shambaai, in the region surrounding the capital. Kinyashi had, however, expanded the kingdom dramatically. He had put sons in two of the most important territories of northern Shambaai, which had never before been governed by Kilindi chiefs (Mlalo and Mtii). He had also added

---

\*I will discuss how it is possible to know about the events and relationships of a period in the distant past at the end of this section, once the characteristics of the earliest events have been indicated.

chiefdoms governed by sons, and by tributaries of commoner lineages, in the very large area he conquered to the east of Shambaai. At the time Kimweri ye Nyumbai acceded at Vugha, he faced local chiefs whose relationships to him are outlined, to the extent that they are remembered, in fig. 13.

Chiefdom	Governor
<u>Southern Shambaai</u>	
Bumbuli	Kimweri ye Nyumbai
Shembekeza	Half sister, or father's sister's daughter
Mkaie-Tamota	Father's half brother
Bagha	Commoner lineage (tributary)
Mponde	Commoner lineage (tributary)
<u>Northern Shambaai</u>	
Mialo	Half brother
Mtii	Half brother
Mlola	Not governed from Vugha
Mshihwi	Rival kingdom governed by father's half brother's son
<u>Eastern Provinces</u>	Data not specific. Clearly a number of commoner tributaries, and perhaps some half brothers.

Fig. 13 A Summary of the Discernible Relationships between Kimweri ye Nyumbai and the Governors of the Chiefdoms at the time of Kimweri's Accession<sup>1</sup>

By the end of Kimweri's reign (which lasted for more than forty years, until 1862), Kimweri had installed his own offspring in the overwhelming majority of chiefdoms and sub-chiefdoms. Abdallah bin Hemedi 'lAjemy listed 57 of Kimweri's children as chiefs of Shambaai, and 36 in the eastern provinces (1962: Sura 42). The actual number was much higher, since Abdallah tended to list only the senior children of matrilineal houses, and not all the younger sub-chiefs.

The question which must be answered here is, how, and under what circumstances, did Kimweri remove his father's brothers, and father's brothers' sons, in order to replace them with his own sons? There are really two parts to this question. First, what were Kimweri's strategies for establishing effective control? Second, at what stage in the developmental cycle of the Kilindi lineage did Kimweri ye Nyumbai become King? One reason for tracing the development of the politics of the royal lineage over a considerable period of time is that the full cycle took nearly a hundred years. When studying the development of commoner lineages, it is possible to look at a number of lineages at a single point in time, and to infer that the different lineages are at different stages in the same cycle. There were never more than two or three ruling Kilindi lineages, however, and so it is necessary to examine one lineage through an entire cycle, or a full ring in the spiral of its development.

In order to understand Kimweri ye Nyumbai's place in the spiral one must know something about the effects of succession disputes, for Kimweri took the throne one reign after a dispute which split the kingdom. There were two possible results of competition which occurred at times of succession. In the first, the prince who did not accede returned to his own chiefdom, and continued as chief, or left his chiefly position to found a commoner lineage. In the second, the competing chief found a territorial base in order to continue the fight. He hoped ultimately to recapture the capital of the kingdom, while conversely the possessor of Vugha hoped to end his rival's independence. Shambaa describe such a rival kingdom as nguvu ntuhu, 'a separate power.' The existence of a separate and hostile Kilindi power makes it more difficult for the King of Vugha to dominate

his own kingdom. Chiefs who are about to be removed can threaten to join the invading forces of the rival power. Commoners who are about to be punished for an offence can, if they escape, or evade capture, remain free men in the land of the separate power. A Kilindi of Vugha described a late nineteenth century separate power in the following terms: 'Those days it was just the same as with the Germans (with the existence of the border between German East Africa and the East Africa Protectorate). If you committed a crime here, if you fled to (the British side of the border at) Mombasa, you were a free man, because Mombasa was a separate power. In the time of the Kilindi also, if you were in trouble here, and you fled to Mghambo, you were all right. And if a person from Mghambo fled here, he was not given up. He would settle here. But all the while, the King was making war on Mghambo.' One final result of the bitter conflict which accompanied the creation of a rival kingdom is that it was virtually impossible for the actors in the original dispute to end their war. Compromise and peace making were left to future generations.

Kimweri ye Nyumbai's father Kinyashi Muanga Ike had had his authority weakened by a succession dispute, and the subsequent founding of a separate power at Mshihwi, in the barren north-eastern corner of Shambaai. It would seem that Kinyashi's failure to appoint his sons to the chiefdoms of southern Shambaai, near the centre of the kingdom, can be attributed to Mshihwi's threat. In the south, Kimweri faced his father's brothers, or father's brothers' sons. In northern Shambaai, on the other hand, where there had not been chiefs before Kinyashi, the chiefs facing Kimweri were his own half brothers, except at Mlola, the chiefdom nearest Mshihwi, where there was no Kilindi chief. Kimweri thus inherited two advantages as a result

of his father's difficulties. He did not face a unified group of chiefs who could work together to hold on to their offices. And he was in a position to end his father's debilitating Mshihwi war.

Immediately after his accession Kimweri ye Nyumbai attacked Mshihwi in an attempt to eliminate his rival, the son of his father's rival. The attack failed, and the two men agreed to acknowledge each King's legitimacy in his own territory. They met, and each one took an oath that neither he nor his descendants would ever attempt to rule in the territory of the other. They rubbed fragments of a broken cooking pot over some water, then drank the water to seal the oath. They took a small piece of cloth, white in colour, for white is the colour of peace, tore it in half, and each kept half as a record of the oath. The man who was chief of Mshihwi in the 1920's, who was regarded by his subjects as king, the lioness, kept this white cloth in his great house. It can be seen that one characteristic of Kilindi oaths, as opposed to the same oaths as taken by commoners, is that oaths concerning political rights are capable of enduring for great periods of time. There are very few commoners' oaths which endure beyond the oath taker's death. But in this case the oath has been remembered, with the piece of cloth as a mnemonic device, for about 150 years. It can be expected that knowledge of the oath will disappear within the next generation or two, now that the Kilindi have been removed as chiefs. An oath tends to be remembered for as long as the descent groups which participated control the territories with which the oath is concerned. There is a relationship between political office, associated with a territory which is inherited whole and unfragmented, and the duration of an oath.

Kimweri ye Nyumbai, having taken the oath, and having eliminated the threat of Mshihwi, faced the problem of dominating the chiefdoms. The greatest asset for the process of domination, possessed by virtually every King, was the chiefdom of Bumbuli. Kimweri, as the son of the great house, had been chief of Bumbuli before his accession. When Kimweri became King of Vugha, he left Bumbuli without a chief. Bumbuli was therefore the one appointment for which it was not necessary to depose a chief. There were two possible courses open to a new King in the choice of his great wife. One was to designate a woman to whom he was already married as great wife at the time of accession, in order to provide a son of the great house who was mature enough to become chief of Bumbuli, or who was on his way to maturity. The other possible course, the one probably adopted most frequently, was to name a great wife at the time of accession, and to make a full brother chief of Bumbuli while waiting for her to bear an heir. In the conflict between the chiefs, as eldest sons of matricentral houses, and the King, as the eldest son of the great house, the younger brothers invariably supported their full brothers. In each case, what was at stake was not a single office, but the welfare of an entire house. The full brothers of the King would remain influential long after his half brothers had begun to revert to the status of Kilindi of the common homestead. It is impossible to know whether Kimweri first sent a full brother to Bumbuli, or whether he sent his son Mnkande, who ultimately became chief.

Bumbuli and Vugha were two of the most heavily populated chiefdoms of Shambaai, and they were close to one another, with only a few small and insignificant chiefdoms, with easily dominated minor chiefs, between. A new King, by acquiring immediate control of the two, acquired the support

of a large number of easily mobilized men in time of war. The populous territory provided rich tribute in peace time. This territory sat astride southern Shambaai. The remaining chiefdoms of the south formed a fringe around the Bumbuli-Vugha axis. Ubi and Gare, the western portion of the fringe, could not easily combine forces with Shembekeza and Tamota on the east.

The settlement of Mshihwi, and the control of Bumbuli and Vugha, enabled Kimweri to begin the process of taking control of the chiefdoms of Shambaai. There are several discernible regularities in the process of Kimweri's attempts to use his powers of appointment. First, Kimweri tended to fill in empty spaces. There were a great many territories which were at the fringes of chiefdoms, and which had had, until this time, a considerable degree of autonomy under headmen of commoner lineages. Kimweri sent these places the first Kilindi chiefs they ever knew. Second, there were some important chiefdoms governed by well entrenched chiefs who were Kimweri's father's brothers. In these cases, where any action to remove a chief would appear disrespectful in terms of descent, Kimweri waited for the death of the old chief before acting to dominate the chiefdom. He did, however, attempt to split these chiefdoms, putting his son in one half of the chiefdom, and leaving his father's brother in the other half, so that when his father's brother died, the successor as chief was surrounded by Kimweri's men. Third, in a number of chiefdoms Kimweri sent a chief whose mother's lineage was prominent in the chiefdom, so that the new chief would have local support. Finally, Kimweri did not attack a chief, or demand that he step aside, until he, as King, had placed his sons in a number of nearby chiefdoms, so that he could bring overwhelming force to

bear if necessary.

In order to examine in detail the process by which Kimweri achieved domination, and to reach an understanding of the descent basis of the internal organization of the chiefdoms, I propose to describe the process for the most important chiefdoms in the western half of Shambaai: Gare, Ubii, and Mlalo. One additional example which is not in the west (Mponde) will be given because in it, Kimweri carried his use of alliance to an unusual extreme.

One of Kimweri's first wives, in the period before he became King, was a Nango woman from Ubii, which was then in the chiefdom of Gare. At the time Kimweri succeeded, Gare was the only major chiefdom between Vugha and the Mbugu forest to the north-east. Gare was controlled, at that time, by the house of Dafa, a half-brother of Kimweri's father Kinyashi.

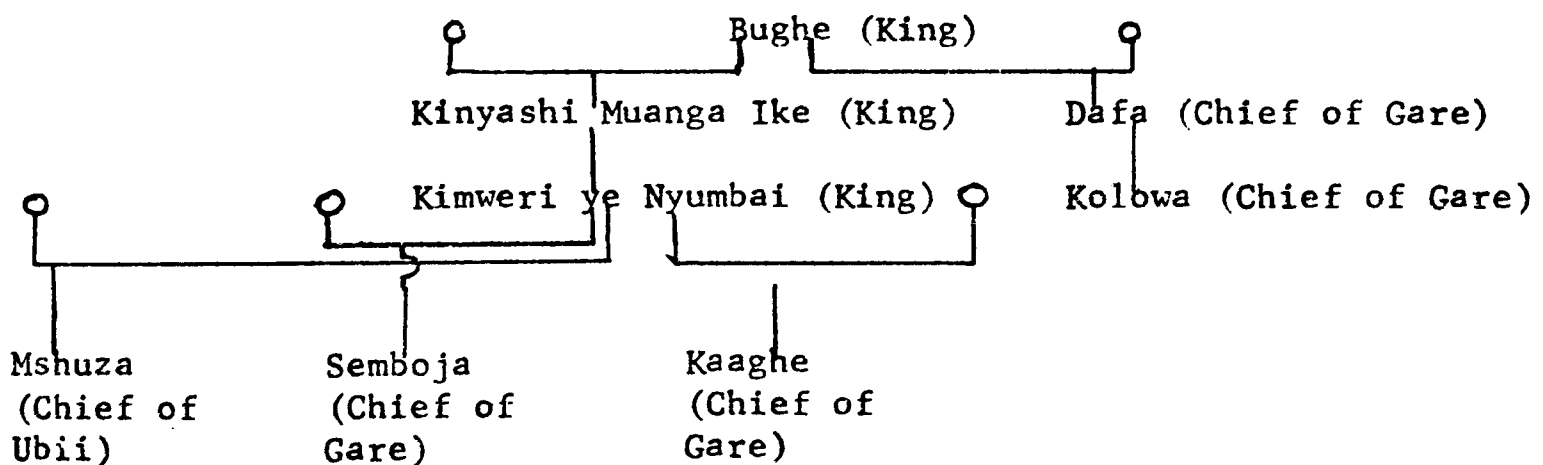

Fig. 14 Schematic Representation of the Descent Positions of the Chiefs of Gare and Ubii at the time of Kimweri ye Nyumbai

It is not clear whether Dafa was still alive at that time, or whether he had already been succeeded by his son Kolowa. Kimweri ye Nyumbai, as a new King, could not afford to attack an established chief directly, for then all the chiefs would join forces against him. Instead he sent the

wife who came from Ubii back to the land of her own patrilineage; her son Mshuza went with her as chief of Ubii. Thus, instead of deposing the chief of Gare, Kimweri set up a competing chief, with strong local links, beside him. Mshuza took a Hea woman of Ubii as his own great wife, for the Hea were one of the two important descent groups of Ubii, along with the Nango (his mother's group).

Only once Mshuza was established at Ubii did Kimweri ye Nyumbai remove the house of Dafa at Gare. Dafa's mother had been an Mnango of the Wavina Nkaa sub-clan -- an important Gare group. When Kimweri took control of Gare, Dafa had already died, and so the King was not in the position of attacking a Kilindi of his father's generation. The chief, faced with the choice of retiring voluntarily, or facing attack from both Vugha and the neighbouring chiefdom of Ubii, retired. Kimweri sent his son, Semboja, as chief.

The most important of the chiefdoms along the northern edge of Shambaai was Mlalo, governed by Mahimbo, son of Kinyashi, a half brother of Kimweri ye Nyumbai. Kimweri waited, before taking over Mlalo, until he had consolidated his rule in the southwestern part of Shambaai, at Ubii and Gare, across the Mbugu forest from Mlalo. In addition, Kimweri controlled Mlola, the chiefdom immediately to the east of Mlalo. Mlola adjoins Mshihwi, and so it had not had a chief during Kinyashi's battles with the rival power. It is possible to know the order in which these chiefdoms were taken because we know that the son Kimweri sent to Mlalo was considerably younger than Mshuza of Ubii, Semboja of Gare, or Msangazi of Mlola.

There are two traditions I collected concerning the removal of chief Mahimbo of Mlalo. These conflict in some details, and yet they are remark-

ably similar in their description of Kimweri's threats of force - in the one implied, in the other explicit. The first tradition is by a Kilindi of Shembekeza, far removed from Mlalo, who had learned much of the general history of the Kilindi beyond the borders of his own chiefdom. Dafa, Kimweri's son who became chief of Mlalo, should not be confused with Dafa (son of Bughe), the early chief of Gare.<sup>2</sup>

Kimweri's brother was at Mlalo. But then the King thought to himself, "What should I do about this? Mlalo would be a beautiful land to possess." He took his son Dafa, and said to Mahimbo, "Friend, live together with your child. You will keep one another company." Mahimbo said, "What is my elder brother doing? Why has he brought a person here?" Then Mahimbo drank poison and died.

The second tradition about Mahimbo and Dafa was told by a Kilindi of Mlalo, and is therefore linked to the event by an identifiable chain of transmission.

Kimweri begat children at Vugha. As those children grew up there was conflict with the chief of Gare. Then when that was finished, they made plans to remove Mahimbo. They threatened that Mahimbo would be killed in war. That was why Mahimbo left. He went to live in a small village away from the centre of politics, here in the chiefdom of Mlalo. Then Dafa was brought as chief.

Other traditions say that Mahimbo stepped down voluntarily, because that is the proper behaviour for a chief whose brother becomes King. These can be ignored, since they are demonstrably not valid as general descriptions of reality.

Dafa did not have matrilateral ties to the people of Mlalo. His mother was from Mulungui, far to the south. But he was careful not to offend the most powerful of Mlalo's descent groups. The Kijelwa had independent control of the territory around their town of Kijelwa (later Ngwelo), and they retained it under Dafa. In addition, it seems probable that the Kijelwa performed rites for the welfare of the land under Dafa. The Kijelwa

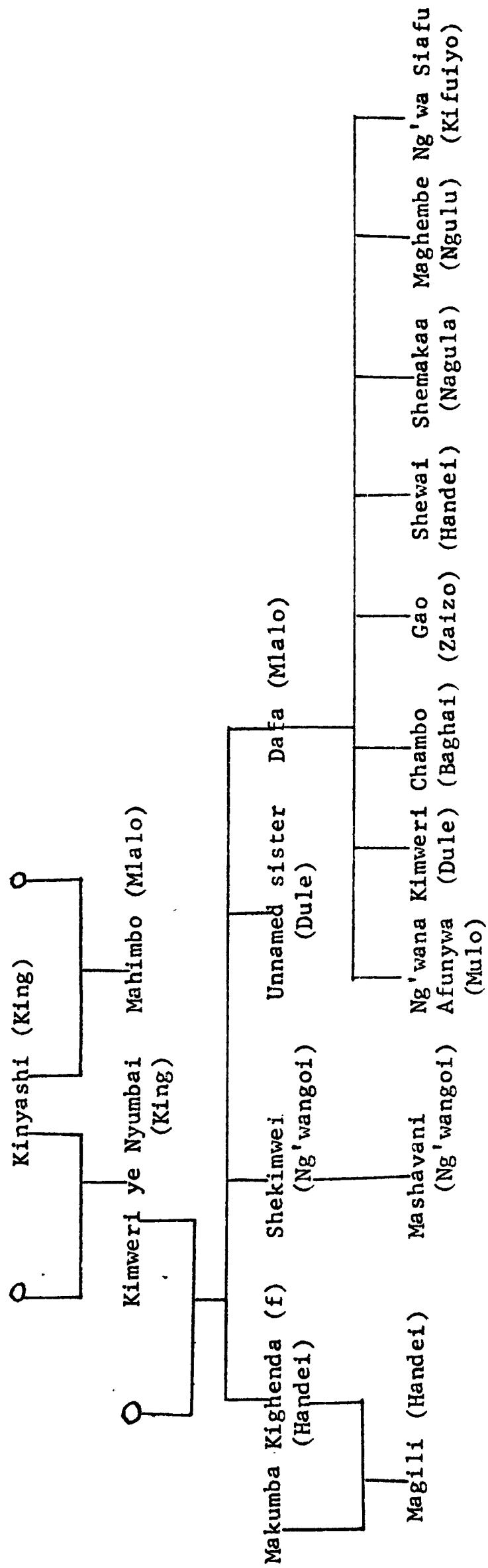

Fig. 15 Schematic Representation of the Kilindi of Mlalo during the Reign of Kimweri ye Nyumbai

are remembered as the ritual experts of Mlalo. At the chiefly burial site established for Dafa and his descendants, a Kijelwa ancestor is invoked before any of the Kilindi. The Nango and Kwizu also retained autonomous villages under the chiefship of Dafa.

In addition to the chiefdoms Kimweri took from his half brothers, or father's brothers, there were other territories which had been at some distance from royal villages, which had governed themselves, and had never had Kilindi nearby. Kimweri consolidated his position by adding chiefs at these places, to which he could appoint his sons without having to depose earlier Kilindi. Bagha was one such place, Mponde, near Vugha, on the path to Bumbuli, another. Even at these places, however, Kimweri ye Nyumbai acted with great care to cooperate with the prominent commoner descent groups, and to give them an interest in Kilindi rule.

Kimweri's cooperation with local descent groups was carried to an unusual extreme at Mponde. Because there had been no chief at Mponde, the Washu Waja Nkobo, the most prominent local group, had retained a considerable degree of autonomy. Kimweri married the sister of Shemdoa, a member of the group, and sent Shemdoa's daughter's son, Mkanka Mghanga, as chief of Mponde, and Mkanka Mghanga's siter (Mahombwe) as chief, or possibly sub-chief, at Ngwilu, nearby. Shemdoa's sister, the mother of the chief, moved back to Mponde, to be near her son and her own patrilineage. Then there occurred an event which upset all of Kimweri ye Nyumbai's careful plans. Here is a description of the event by one of the Kilindi of Mponde, the aged son of Kibanga, who figures in the tradition:

The conflict between Mkanka Mghanga son of Kimweri ye Nyumbai and his mother's brother Shemdoa began with the picking of gourds . . . . There was a banana garden named Machalo in

which there were some gourds. When Shemdoa returned from hunting one day, and picked some gourds, it made his sister very angry. Brother and sister fought about it, and that was the beginning of the entire dispute. After a while the sister died. Mkanka Mghanga left Mponde and went to his mother's lineage village, to be at the mourning ceremonies. He arrived, and slept at the house of a man named Twakiondo. When he had slept, he had a talk with Twakiondo, who said, "Your mother didn't just die. She was killed by Shemdoa" (because she had broken a cooking pot after the argument). "Really?" "Yes." Shemdoa was here in this village. (Mkanka Mghanga) left to come here. He arrived and took his uncle out, and they went up the hill together to the place where the school is now. (Mkanka Mghanga) killed him there . . . Then Kimweri sent the Kaoneka (a court official) from Vugha . . . . The Kaoneka . . . said, "My friend, how could you kill your mother's brother?" Mkanka Mghanga said, "She didn't just die. She was killed by her brother." Mkanka Mghanga was told, "You are very stupid to kill your mother's brother because of your mother's death." (Then Mkanka Mghanga was removed from Mponde and sent to be chief of the very small territory of Mpare, near Mulungui, in the south. His sister Mahombwe was made temporary chief of Mponde.) Then Kimweri ye Nyumbai said to the men of Vugha, "Men, you must forgive me for the shameful thing I am about to do. I am going to marry my brother in law's (Shemdoa's) daughter, so that I can beget a chief of Mponde. And that was how Kibanga was born."

Kimweri ye Nyumbai's relations with the Washu Waja Nkobo lineage in Mponde were not typical. In a great many instances Kimweri sent chiefs whose mothers were from distant chiefdoms, although even in these cases, the mother's brother of the chief often went along to supervise the education of his sister's son, and to mediate between chief and commoners.

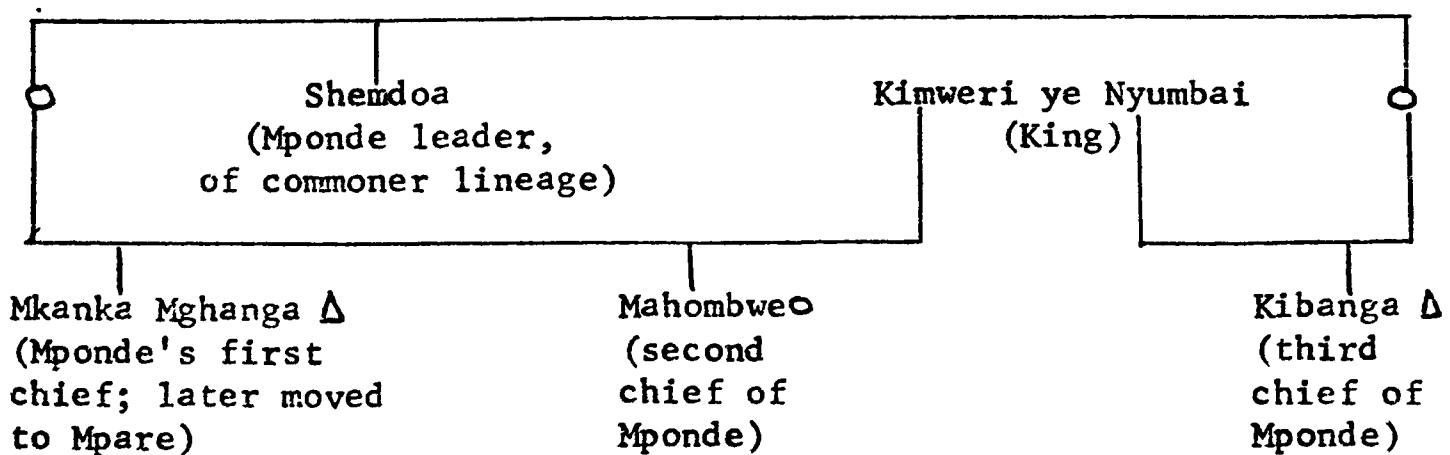

Fig. 16 Schematic Representation of the Chiefs of Mponde

In each chiefdom, once a matricentral house was installed, the chief, as the senior member of the house, distributed sub-chiefdoms to his siblings and children. Mshuza of Ubii had at least six sons, each of whom was given a small portion of the chiefdom to govern. There was one young Kilindi at Ubii, however, who was not a member of Mshuza's house. This was Kiunguia, son of Kimweri ye Nyumbai. Kiunguia's mother had died during his infancy, and he was brought up by Mshuza's mother, Mamshuza. When the foster child reached maturity, Kimweri gave him the distant chiefdom of Shembekeza, on the eastern edge of Shambaai. Mamshuza is reported to have said to Mshuza, "I cannot let my child go to Shembekeza, for I am very old, and cannot go through the dangerous forests to visit. If he has a pregnant wife, who will look after her? Go and speak to your father Kimweri, and tell him that you wish to give Kiunguia a portion of your chiefdom." Kimweri agreed, but the section of Ubii given to Kiunguia (at Ngulwi) was considered a separate chiefdom, even though it was dependent on Mshuza. Unlike the sub-chiefdoms of Mshuza's sons, Ngulwi was the property of a separate matricentral house. The word used in the traditions to describe Mshuza's award of territory is ukomea, literally the part of a house near the front door which is protected from the rain, but which is not inside the house. The separation of Kiunguia's chiefdom paralleled the practice in commoner lineages of keeping a woman's fields separate after her death, so that her sons would have the property of their own matricentral house at their maturity, even though they had been brought up by another woman and were merged with her house during their childhood.

The pattern of rule by the matricentral house of Dafa at Mlalo appears, at first glance, to have been slightly different from Mshuza's rule at Ubii.

Dafa had no children when he arrived at Mlalo; his earliest sub-chiefs were full siblings, most of whom were replaced, after a period, by his sons. (For details of Dafa's house at Mlalo, see fig. 15.)

The eldest of Dafa's siblings was a woman named Kighenda, who was made sub-chief of Handei. She soon married the man who had until then been the most important informal leader among the commoners of Handei. This alliance made it possible for Kighenda to drive out the sub-chief Dafa sent to replace her. Kighenda was removed so that Dafa's son Shegao could become sub-chief. Handei at this time must have been virtually impossible for Shegao to govern, for Kighenda was a very senior former sub-chief, and the commoner lineage of Handei saw a chance of making their own lineage member -- Kighenda's son Magili -- sub-chief. After Shegao had failed, and moved to another sub-chiefdom, Kighenda's son took office. He, however, fought bitterly with his mother's brothers, the Kilindi, who resented the award of an office to a non-Kilindi. After his failure, and one further unsuccessful chief, Shewai son of Dafa, the most forceful of the Mlalo Kilindi, with the greatest reputation as a fighter, took over the sub-chiefdom. His descendants held it until the end of British rule.

At the sub-chiefdom of Dule, another sister of Dafa's took office. She too married a local man. But when Dafa had a son of the appropriate age, Kimweri, the son, took office in Dule, and his descendants were not replaced through the entire period of Kilindi rule.

Eight sons of Dafa are remembered by the Kilindi of Mlalo as the first sub-chiefs in each of their respective territories. But there is a tendency to drop, from the traditions, early sub-chiefs who were Dafa's siblings. The former chief of Mlalo, for example, maintains that Dafa's son was the

first chief of Dule, while the Kilindi of Dule remember the earlier rule of Dafa's sister. One wonders whether this form of structural amnesia did not take place at Ubi, where, as we have seen, Mshuza's sons are remembered as the first sub-chiefs.

At least one brother of Dafa was never replaced as sub-chief. Shekimwei, at Ng'wangoi, was succeeded by his son several days before Dafa's death. Shekimwei's descendants governed Ng'wangoi for the full duration of Kilindi rule.

In the case of Dafa's brother at Ng'wangoi, and in the cases of Dafa's sons in the other sub-chiefdoms, once a sub-chief was successfully established, he and his descendants were not removed from office. The sort of struggle Kimweri ye Nyumbai waged at the level of the kingdom, which led to the removal of all Kilindi down to the lowest sub-chief, does not seem to have been duplicated with the succession of each new chief in Mlalo, or in Ubi, or Gare, or the other chiefdoms. This was true also for the period before Kimweri ye Nyumbai; when a King did not remove chiefs, those who inherited chiefship did not remove sub-chiefs. One possible reason is that it would have been difficult for a chief to argue that his entrenched local line should not be removed by the King, while at the same time he removed the local lines of his subordinates. The effect of leaving lineages of sub-chiefs intermarrying with commoners at the local level over a period, was to blur the lines which separated Kilindi and commoners, to integrate the Kilindi into the local community. This was the soundest defence of the Kilindi of a chiefdom against the encroachments of a new King of Vugha or of a covetous chief in a less important chiefdom.

The matricentral houses of Kimweri's children competed vigorously with one another. Kimweri did not interfere with a lesser chief who attempted to undermine his half brother's rule in order to take a more important chiefdom. Kilindi within the single kingdom, however, were not allowed to make open war on one another. Kilindi warfare was only permitted between competing kingdoms, as between Vugha and Mshihwi, but never between chiefdoms of a single kingdom.

Because Kimweri's authority as a father over his sons reinforced that of King over chiefs, he could employ sanctions against what he regarded as improper, or more especially impolitic, behaviour. The word used for Kimweri's application of sanctions is -shunda, to punish or chastise. This is the word used to describe an ordinary father punishing his children. The most extreme sanction was the removal of the chief from his territory to a less important one, or to one in which the job of chief was less rewarding in tribute and more difficult. We have already seen that Mkanka Mghanga of Mponde, after killing his mother's brother, was sent to a very minor chiefdom.

The most significant instance of competition between chiefs under Kimweri ye Nyumbai, which resulted in the application of sanctions, was the conflict between Mnkande, the son of the great house at Bumbuli, and Ng'wa Kimungu of Shembekeza. Ng'wa Kimungu had been sent by Kimweri to Shembekeza to replace a woman chief named Okwaho, who was descended from an earlier King. No one at Shembekeza to whom I spoke remembered much about Okwaho. Ng'wa Kimungu and Mnkande sent sorcery charms back and forth between Shembekeza and Bumbuli, each one trying to prove his skill as a medicine man. Then Mnkande died, his death commonly attributed to Ng'wa Kimungu's charms. Kimweri sent Ng'wa Kimungu to one of the chiefdoms of

East Usambara, out of Shambaai altogether, and gave Shembekeza to Ng'wa Kimungu's full sister. Mnkande's death set the scene for the major conflict over succession after Kimweri ye Nyumbai.

Kimweri's domination, his ability to apply sanctions, is often referred to by commoners when they explain why Kimweriye Nyumbai's reign was a better time for commoners than any period of Kilindi rule since then. In cases where a chief behaved improperly toward his subjects, the commoners could get redress. They would complain first to the mother's brother of the chief, who was a commoner like them, and yet the chief's 'feminine father.' If the chief persisted, then either the mother's brother or a group of commoners could bring the complaint to the attention of the King at Vugha. Since Kimweri's sanction was to send the chief to a more distant territory, and since it was more difficult to come to Vugha from a distant chiefdom, the commoner's right to redress was more limited at the distant fringes of the kingdom.

There is one known case of Kimweri removing a chief from his territory because of the complaints of commoners. Even if this was the only occurrence at the time, it must have given heart to commoners all over Shambaai, while moderating the behaviour of chiefs. Semboja son of Kimweri ye Nyumbai was sent to Gare as a young boy of about eight with his mother's brother (a Gare man) as guardian, educator, temporary judge, collector of tribute for immediate use and in trust, coordinator of rites for the welfare of the land. Semboja, who was later to become a terrifying slave raider, was even as a child a difficult person. It was reported that he shot with poisoned arrows at the treasured hunting dogs of his subjects. When Semboja's guardian handed over control, the commoners waited for a suitable incident to complain to Kimweri. This came when some cows wandered into Semboja's maize garden,

and he chopped with a bush knife at their legs. After this and one further complaint, Kimweri removed Semboja as chief of Gare. The young chief was sent to Ngua, which was seen as a suitable position: it was a small and insignificant territory at the southwestern corner of Shambaai, overlooking the plains at a point where the Maasai and Iloikop, moving through, were forced to follow a path near Shambaai, between Ngua and the Zigula mountain of Mafi facing it. According to the traditions, Kimweri felt that Semboja's violent temperament would be usefully employed against the Maasai. The situation developed quite differently, when the Maasai path became a major trade route; Semboja moved down to the plains at Mazinde, and allied himself with the Maasai.

One can see, in Semboja's career, evidence for the unshakeable authority of a King, once the descent configuration associated with domination was achieved. Semboja's behaviour was clearly not governed by popular notions of propriety. He did not hesitate at violence, nor was he anxious to avoid being called a witch. He publicly violated the conditions of mourning after his father's death (Abdallah bin Hemedi 'lAjemy 1962: Sura 73). Yet he never, so far as is known, attacked or ridiculed his father. Semboja did not attempt to overthrow his father, nor did he resist when told that he had behaved badly, or when sent to a minor chiefdom. If he had attacked his father, Semboja would have been opposed by all his brothers. Once Kimweri ye Nyumbai made his sons chiefs, any act of rebellion by one son would have been seen as the beginning of the contest among the next generation of potential Kings. If Semboja had rebelled against his father, it would have been fair to assume that he intended not only to take Vugha away from the next great house, but also to depose all the chiefs and to

install his own sons in their places. Once the descent configuration associated with domination had been achieved, any attack on the King would have been seen as an attack on all the chiefs. Semboja did not attack his father because he could not have won.

Back at Gare, Kimweri sent another chief, Kaaghe, this time with maternal ties to Shashui, at the edge of Vugha's territory nearest to Gare. Kimweri was undoubtedly anxious that the debacle of Semboja's rule not be repeated. According to the son of Kaaghe's maternal uncle, Kimweri gave the uncle careful instructions:

My father had a village at Vugha and a village at Shashui. Chief Kaaghe was the son of my father's sister. When Kaaghe was sent to Gare to rule, my father's father had already died. The Kimweri ye Nyumbai said to my father, "Please follow the boy to Gare. I want you to follow him, for when he does cruel things to the people of Gare there will be no one to discipline him. Go to Gare together with your sister and watch the lad. Keep track of the good things he does and the bad." Then father came to this land . . . and if the people of Gare were angry at something they would come to father and say, "Look at what your child has done." Father would tell him, "Son, the people of Gare are angry. They have been angered by such and such. If you keep on doing that I will go to tell Kimweri at Vugha."<sup>4</sup>

The chiefs and commoners of the former kingdom all agree that the years of Kimweri ye Nyumbai were the great age of Kilindi rule -- the chiefs because the descendants of Kimweri ye Nyumbai were never removed by a later King. Every Kilindi who ruled up to the end of 1962 owed his legitimacy to descent from Kimweri ye Nyumbai. The commoners share the view, because according to indigenous political notions, a King who dominated his chiefs protected the commoners from predatory local Kilindi. The commoners would protect such a King, it is said, and the King would regard the commoners as his natural allies. In the days of Kimweri ye Nyumbai, the traditions say, there were no violent raids, no unfair judgments. "Kimweri ye Nyumbai placed sons in

the chiefdoms, and he was respected . . . . Ah, in those days there was nothing but peace and good will in the land . . . . Such peace is not seen in the days of every King. It was seen in the days of Kimweri, because if a person had no wealth, if his wife's lineage was about to take her from him, he could say, 'Oh King, my wife is being taken.' Kimweri would say, 'Go to the following place. There is a cow of mine which you may take.' He didn't like to be told, 'This is the son of so and so.' He liked to say, 'They are all my children.' And when he sent a son to rule, he would say, 'You are to build a village, and live nicely with your companions, so that there is no conflict. In judging cases, show an evil man his own evil. But if there is a man with no evil, don't introduce evil into his life.'"

How, then, has it been possible to reconstruct a relatively probable record of Kimweri's reign for the chiefdoms discussed? This can best be answered with reference to traditions about the Kilindi of the common hearth. If one collects versions of the commonly recited traditions on the Kings of Wugha, one is told that Mbegha, the first King, had one son, Bughe; Bughe had one son, Kinyashi Muanga Ike; Kinyashi had one son, Kimweri ye Nyumbai; and then Kimweri sent sons to all the chiefdoms of Shambaai. One is told that before Kimweri there were no local chiefs. Then one begins to work at the local level. At Gare-Ubii, for example, the overwhelming majority of old men will probably say that before Kimweri ye Nyumbai there were no chiefs at either Gare or Ubii. But a few of the most expert will say that there had been an older Kilindi line before Mshuza or Semboja, for there is a disused burial site, and in addition the descendants of the earlier Kilindi can still be found at a particular village. The expert men will probably repeat, when naming the Kings of Shambaai, that Kimweri ye Nyumbai was the first to send

his sons to the chiefdoms, but now one can go to the descendants of the earlier lines, to hear their private traditions of their own descent. No one tradition can be relied on, but the larger pattern of traditions compared to one another is revealing.

In order to reconstruct the pattern of relationships at Gare-Ubii, for example, I collected the accounts of two descendants of Dafa, the Kilindi who governed Gare before Kimweri ye Nyumbai, and one descendant of Dafa's sister's husband, who governed a sub-chiefdom under Dafa. Then there were three descendants of Mshuza, two of Semboja, one of Kaaghe, as well as Kaaghe's mother's brother's son. I spoke with two representatives of the Hea clan at Ubii, and one of the Nango (in addition to many Hea and Nango in other places). Semboja's early career is also described in a tradition recorded by Karasek at the turn of the century, shortly after Semboja's death (1923-1924: 46-50).

In evaluating material collected in this way, one does not trust generalized characterizations so much as descriptions of specific events. Traditions stating that Kimweri removed chiefs in response to complaints by commoners are relatively useless as descriptions of past occurrences, although they are interesting for what they reveal about conceptions of politics. A tradition which states that Kimweri removed Semboja after the complaints of commoners can be relied on more heavily, especially when the tradition is told by a descendant of Semboja who should be interested in hiding the lineage scandal. Bits of information which appear to be of no particular interest to the possessor of the tradition are the most useful, when they can be put into the context of a larger pattern of relationships. The identities of a former chief's wife and mother's brother are unlikely

to be matters for genealogical revision, and yet when many such identifications are looked at together, a significant pattern emerges.

The greatest difficulty to this approach is that it depends on luck, on the expenditure of a great deal of time, and on knowledge of local lineages in many places. This means that one's knowledge cannot be of equal value for all chiefdoms. It happened that in Mlalo, in Ubii-Gare, and in Mshihwi I found the traditions of a great many local lineages which had contact with one another in each place during the reign of Kimweri ye Nyumbai. I lived at Mayo and Shembekeza much longer than I lived at Mlalo, and I never lived at Gare or Ubii. Yet at Mayo-Shembekeza (near Bumbuli) I was never able to find representatives of important lineages who could tell me anything beyond the name of Kimweri's son, and the name of the son's predecessor as chief. In other places, the Kilindi traditions described how a particular son of Kimweri ye Nyumbai was the first chief, and yet there was no way of supporting or discrediting such a statement. In still other places, such as Mponde, the statement that Kimweri's son was the first chief was substantiated by traditions on the identity of the political leader before the Kilindi presence, and of the relationship between the earliest Kilindi and the last local informal leader.

This rather laborious and tenuous procedure was followed because it seems virtually impossible to come to a serious estimate of the characteristics of the autonomous Shambaa political process -- of the nature of conflict, and the balance of forces -- from descriptions of political action in the colonial period. Ultimate authority was with the district officer, the provincial commissioner, those in the territorial capital and London. Mary Douglas puts it well when she says that 'In a sense all colonial

anthropology takes place in a teacup.' One cannot observe any real storms and upheavals (1966: 111).

#### IV

The period of storms and upheavals in the Shambaa kingdom came after the death of Kimweri ye Nyumbai. Since the crucial events of this period all involved the King at Vugha, and were interconnected, they are easier to describe in abbreviated narrative form than the early years of Kimweri ye Nyumbai. I propose to present first, a brief bare narrative of the occurrences of the period, and then an explication of the relationships of descent and alliance involved in each set of actions.

##### Narrative:

The transfer of the kingship began before Kimweri ye Nyumbai died. Kimweri became very old and feeble. He was no longer able to hear cases, or to arrange the affairs of the kingdom forcefully, and so he decided to pass on control of Vugha to a successor. We have already seen how Mnkande, the son of the great house, heir to Vugha, had been killed. Kimweri's decision was to pass on the kingdom to Mnkande's son Shekulwavu, in order to keep the kingship in the great house. Kimweri insisted that his eldest son, Mshuza of Ubii, take an oath that neither he nor any of his children would ever govern Vugha. Shekulwavu decided cases at Vugha, and kept the King's share of the fines. Kimweri ye Nyumbai, meanwhile, stayed in one of his private villages.

When Kimweri ye Nyumbai died, Shekulwavu acceded, and took full control of Vugha. Shekulwavu was King for six years, but during that time he made appointments to only a handful of chiefdoms. He gave his full brother,

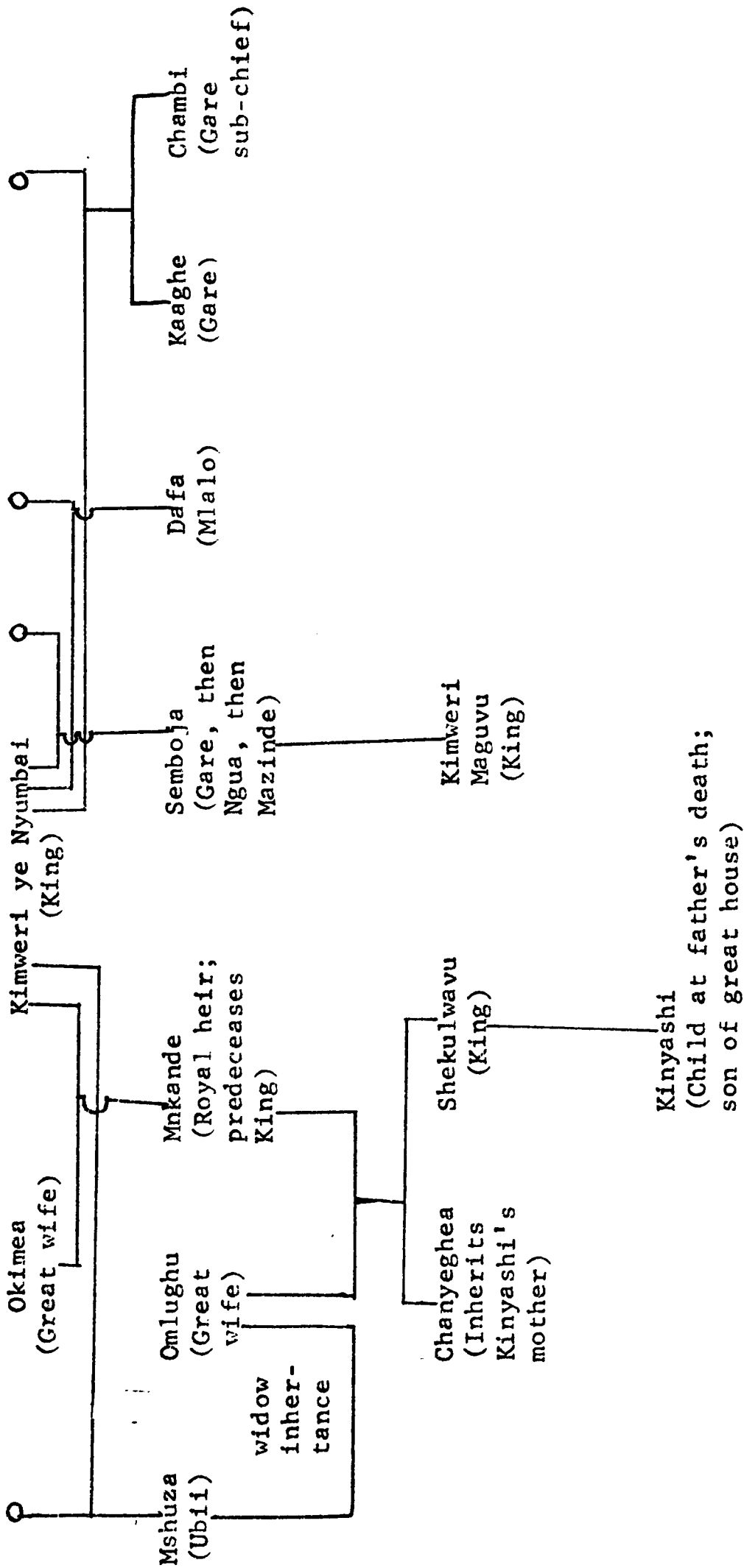

Fig. 17 Schematic Representation of Important Kilindi in the Succession Dispute after Kimweri ye Nyumbai's Death

Chanyeghea, the chiefdom of Bumbuli, which had been vacated for Shekulwavu's move to Vugha. His half brothers were given chiefdoms: Kibanga was given Manka, between Bumbuli and Vugha; Makange was given Bagha, at the edge of Vugha's territory; Mwelekwa Nyuma was given Ngulwi, at the edge of Ubi. Shekulwavu's sister Chamviga had already been appointed to Shembekeza by her grandfather Kimweri ye Nyumbai, after the chief of Shembekeza had (it was believed) murdered the royal heir.

All of the major chiefs, however, retained control of their chiefdoms. Shekulwavu was unable to remove them. Shekulwavu's relations with Mshuza of Ubi, and with Semboja of Mazinde, were especially difficult. After a series of quarrels with Shekulwavu, Semboja and Mshuza decided to have a pair of their sons make the blood pact. Then the two men sent messengers outside Shambaai, to the land of the Taita, to request a body of Taita soldiers. The Taita attacked Vugha, drove out Shekulwavu, and burned the capital. Shekulwavu fled to the plains, where he continued his battle against the forces of Semboja. Several weeks after Shekulwavu fled to the plains, his gun exploded in his hands, and he died.

#### Explication:

Shekulwavu could hardly have had a more dramatic and complete failure as King. Not only did he fail to remove the chiefs; in the end he was removed by them. The most important single factor in Shekulwavu's failure was the conflict between the expectations associated with his position as King, in his relationships with his 'subordinate' chiefs, and the expectations associated with his position as brother's son, to whom the chiefs were father's brothers. Shekulwavu the King was expected to dominate his chiefs. But one is expected to regard any lineage member of one's father's genera-

tion with distance and respect. It is true that Shekulwavu inherited the wealth of Kimweri ye Nyumbai, as well as some of his grandfather's wives. In this sense, as heir in an alternate generation, he was justified in calling men of the senior generation his 'children.' But this was merely a polite fiction. No one lost sight of the fact that Shekulwavu was a 'child' of the chiefs, in terms of both generation and relative age.

The removal of chiefs was especially difficult for a number of reasons. First, the chiefs were all half brothers, and they recognized that a threat to any one of them was a threat to all. They knew that with the removal of each chief, the removal of the next would have become easier. Second, the chiefs were mature men by this time, with sons as sub-chiefs. They had established numerous ties of alliance with the commoner lineages of their own chiefdoms. Not only with their mother's brothers, where these were local people, but with the lineages of their many wives, and of their sons' wives in the sub-chiefdoms. Shekulwavu might have been able to make one or two important marriages in each of the chiefdoms, but none of his children were old enough to govern, or to marry. Third, Kimweri ye Nyumbai had left no open spaces to fill in. Kimweri himself had begun by putting his sons where there had been no chiefs. But Kimweri had done such a thorough job of it that there was no possibility for Shekulwavu to place sons alongside his father's brothers, and wait for the men of the older generation to die. The Shambaa themselves remark on the importance of this. According to one tradition, the men of Vugha said, "Your father's brothers have sons, and the chiefdoms will simply be passed on, for they have filled the land . . . It would be better if you had a place for each son to be chief, but while your fathers are there, what can you do?"<sup>5</sup>

The conflict was especially great in the relationship between Shekulwavu and Mshuza of Ubii, for Mshuza had inherited Shekulwavu's mother, and was therefore regarded as his paternal guardian. Any chief who was removed or threatened with removal complained to Mshuza, who was expected to guard the interests of his half brother, and to command the obedience of his wife's son. This conflict became extreme when Shekulwavu insisted that his mother Omlughu live in Vugha rather than Ubii. Omlughu, as great wife, mother of the King, was a source of considerable prestige to Mshuza. Her loss was a bitter blow. Mshuza saw it as a disrespectful act by his inherited son. Shekulwavu undoubtedly saw it as a legitimate attempt to bring a symbol of the kingship to Vugha. According to Mshuza's grandson, it was the chief's sons who were angriest and most bitter at this time, for they saw a man of their own generation and their own age attempting to dominate their father.

Semboja was a great trader by this time, with access to firearms, with alien allies, and with trade goods for rewarding his followers. In a sense, this gave him a source of support outside the traditional Kilindi structure. His alliance with Mshuza, sealed by the blood pact between their sons, had advantages for both of them. Semboja acquired the assistance of the King's guardian, to whom all the chiefs looked for leadership. In addition, Mshuza had taken an oath that neither he nor his descendants would ever take Vugha. Mshuza, having helped Semboja to drive out the young King, could not take the kingdom for himself. Semboja did not have rain magic, but Mshuza had been given important charms by Kimweri ye Nyumbai. Mshuza did not have access to trade goods, foreign chiefs, and mercenaries, but Semboja did.

Semboja and Mshuza faced the conflict of roles between chiefs and King

from the other side. He could not be seen to issue commands to his father's brothers. They, as chiefs, could not be seen to make war on their King. It is for this reason that Taita fighters, and/Shambaa, <sup>not</sup> attacked the capital. If the attack had failed, the two chiefs would have disavowed any knowledge of it. Once the attack succeeded, they claimed it as their own. In this situation, where conflict between roles led to the politics of dissimulation, the Shambaa assumed that Shekulwavu's gun exploded because Semboja had placed a spell on it. Whether or not Semboja had actually done so, the secret and indirect murder of his nephew was seen by those present as characteristic.

I would like, at this point, to give a summary description of the split of the kingdom after Shekulwavu's death, followed by further explication: for with the development of a rival Kilindi kingdom, the royal lineage completed a full cycle from the time Mshihwi broke off in the reign of Kinyashi Muanga Ike.

Narrative:

There was general agreement among the Kilindi of Shambaa that the dead King's young child Kinyashi should become King. This meant that Shekulwavu's full brother Chanyeghea, who had inherited Kinyashi's mother, would take control of Vugha until the child grew up. At the time when Chanyeghea was still preparing to move to Vugha, Semboja met with him and suggested that as men who were interested in reestablishing centralized rule in Shambaa they had interests in common. If they cooperated, Semboja suggested, they could take control of Shambaa, and share the power. Semboja and Chanyeghea took an oath in which each one swore to kill all the Kilindi in his half of the kingdom: Chanyeghea in the east, and Semboja in the west. They drank cooking pot water, then broke the pot and scattered the pieces in the fields. As

soon as Chanyeghea had departed, Semboja called a medicine man to find the pieces of the pot, and to remove the effects of the oath.

Chanyeghea went to the eastern provinces, where the Bondei were anxious to overthrow Kilindi rule. He helped to arrange for a rebellion, in which the Bondei rose up to murder their own chiefs; the Bondei then marched westwards to invade Shambaai, murdering Kilindi along the way. Any Kilindi who escaped, or who fled before the Bondei advance, sought refuge in Mazinde, Semboja's town. The Bondei were ultimately driven out of Shambaai. Chanyeghea founded a small rival kingdom in East Usambara, a thin strip of mountains just to the west of Bondei. The Kilindi of Shambaai agreed to make Semboja's son Kimweri Maguvu King of Vugha, and Vugha's struggle to dominate the chiefdoms began again. The younger brother of the chief of Mlalo, and the younger brother of the chief of Gare, joined forces with Chanyeghea. The Gare chief was killed by Maasai raiders. At the time of German conquest, Kimweri ye Nyumbai's houses were still in control of the major chiefdoms.

#### Explication:

In the period before Shekulwavu was driven out of Vugha, virtually all the chiefs of Shambaai had been united against the King. Once the King had been killed, however, new lines of tension developed between Semboja and the chiefs. Shekulwavu's son was chosen as King not only because he was the 'legitimate' heir, but because the regent would be relatively powerless to remove chiefs, since the house of Mnkande had already been driven out of Vugha once for attempting to dominate the chiefdoms. Semboja as King was considerably more likely to murder chiefs, or plot to bring about their retirement. Even after Chanyeghea had discredited himself, the chiefs of Shambaai refused to allow Semboja to become King. They preferred a King of

the generation of their sons, so that they could preserve their independence by arguing that a King of that generation had no right to issue commands. The way in which the chiefs saw their relationship to the King is shown in the following conversation, attributed in a tradition to Kaaghe son of Kimweri ye Nyumbai, chief of Gare, and his younger brother Chambi: "Chambi said to Kaaghe, 'Let us make war on him, for he has taken all the wealth.' Chambi wanted to divide the wealth of his father, Kimweri ye Nyumbai. Kaaghe refused, he said, 'He may be our child, but he has inherited our mothers (i.e. women of our mother's generation).'"

Semboja's plot with Chanyeghea for the murder of the Kilindi is a magnificent example of the politics of dissimulation. Semboja had no legitimate claim to the kingship; his was a minor house. He therefore plotted to discredit the legitimate successor. In addition, he had been seen to be responsible for an attack on the royal capital, and the murder of the King, both of which were reprehensible acts in terms of Shambaa notions of proper political behaviour. Semboja succeeded in getting Chanyeghea to commit multiple murders, and to attack the chiefs, who, as a group, supported Chanyeghea's claims and opposed Semboja's. The greater the number of chiefs killed by Chanyeghea, the easier it was for Semboja to dominate the kingdom afterwards.

With the establishment of the rival kingdom in the east, the Kilindi lineage, all descendants of Kimweri ye Nyumbai, split, with the descendants of Mnkande (Shekulwavu's father) no longer attending the mourning ceremonies of the rest of the Kilindi. The lineage of the eastern Kilindi, which included the grandchildren of Mnkande through a number of Mnkande's sons, was still seen as a matricentral house -- a lineage descended from Kimweri ye Nyumbai's

great wife, Mnkande's mother.

The existence of the rival kingdom made it more difficult for Semboja and his son Kimweri Maguvu to remove the chiefs of Shambaai. When Mlalo and Gare were threatened, the younger brothers of the chiefs of those territories joined forces with the men of the rival kingdom, which was a separate sovereign power. Kimweri Maguvu accused the two chiefs of rebellion, but they denied any control over the actions of their wayward younger siblings. In this elaborate game, Kimweri could not attack his father's brothers, but he did have the Maasai (amongst whom both he and Semboja had blood partners) make a cattle raid on Gare, in which Kaaghe son of Kimweri ye Nyumbai, the chief of Gare, was killed. When Kaaghe's son informed Kimweri Maguvu that he understood what had happened, and that he refused to give up the chieftom, Kimweri Maguvu left Kaaghe's house in Gare, but took half the chieftom to give to one of his own daughters. At Mlalo, the attack was made by Pare fighters. It was beaten off, and the chief of Mlalo was subsequently treated as autonomous. He did not pay tribute to Vugha, nor was he bound by orders coming from Vugha or Mazinde.

During the reign of Kimweri Maguvu, with the continuation of the configuration of competition between King and chiefs, the relationships between Vugha and any given chieftom varied according to the relative power of Kimweri Maguvu and the chief. Kimweri Maguvu appointed the chief of Bagha, and so he was able to issue commands, and to collect tribute. He would have been able to remove the chief of Bagha. But Mshuza of Ubii controlled the rain charms Kimweri Maguvu needed in order to govern; the King of Vugha made livestock payments to the chief of Ubii in return for rain-making rites. Important political decisions were often made for the entire kingdom at Mazinde, since the chief was the father of the King.

## V

The line of reasoning in the second half of this chapter seems to me to be questionable, and yet it has been supported at every point by the evidence. I am convinced against my better judgement. The argument has been that it is profitable to view the Kilindi lineage as a closed system, and to see repetitive regularities in its development. Yet a large scale political system is judged according to the success with which it meets the challenge of changing conditions. A kingdom which cannot defend itself is a failure. During the period under discussion firearms and powder were introduced; trade in these commodities was responsible for the success of a major figure -- Semboja. Through it all the cyclical pattern was not broken. It is possible to treat the Kilindi lineage as a closed system because the lineage was the most pervasive structure for the ordering of relationships among the governors of territories. Shambaa conceptions of the nature of office, of the relationship between King and chiefs, were important also. But, as in so many African kingdoms, the functions and rights associated with the office at the apex of the pyramid were reduplicated in inferior offices. The King had a court for settling disputes, but so did the chiefs. The King collected tribute, but so did the chiefs. We have seen that during the reign of Kimweri Maguvu, the King paid tribute to a chief. Obligations between office holders could be reversed. In the absence of great functional specialization, and great differentiation of offices, the relationships among office holders varied according to their positions in the descent structure.

The lineage cycle worked in the following way. In what I am arbitrarily

calling the first stage, the chiefs were virtually all sons of the King. Personal initiative and competitive spirit were prized among the chiefs, together with loyalty to the father of the kingdom. The King had relied on the most active and aggressive of his sons when removing earlier chiefs. He had also made alliances with as many important local groups as possible. The norms of descent reinforced those associated with office. The King as father could command the obedience of the chiefs his sons. The King could apply sanctions, the most extreme of which was the removal of a chief from his territory. The chiefs considered themselves equal to one another, for they all derived their legitimacy from their birth as sons of the King. No chief would be allowed by his fellows to attack the King; such an attack would rightly be considered an assault on the future positions of the chiefs. The configuration of domination was achieved, as we have seen, by Kimweri ye Nyumbai. It had also been achieved by Kimweri ye Nyumbai's grandfather Bughe.

The second stage in the cycle came when the dominating King died. The effect of succession, after the King's death, was to separate one matricentral house from among the old King's many houses, and to make it preeminent. But the sense of equality among houses of half siblings, which it had been in the dead King's interest to foster, made it very difficult for the son of the great house to dominate the chiefdoms, especially since true domination meant that his half siblings would be removed from office. In addition to the competition among houses, there was competition among commoner lineages, for each house was descended from a woman of a different lineage. It had been in the previous King's interests to emphasize the importance of a given chief in discussions with that chief's mother's lineage. The more important they had thought their sister's son, the more loyal they had been to their

sister's husband. During the second stage the expectations of behaviour associated with descent conflicted with those associated with office. An act of rebellion by a chief against the King could be seen as acceptable competition among houses. When the King removed a chief he could be seen as an unfair elder brother. The conflicting standards were associated with the politics of dissimulation. Chiefs and King would send secret armies of foreigners against one another. In this period neither King nor chiefs could draw on the tribute and support of a large portion of the kingdom. The successful competitors were those who found sources of support beyond the borders of what had been the kingdom until their time. Kinyashi Muanga Ike expanded the kingdom to northern Shambaai and to the eastern provinces, while Semboja had trade allies spread throughout the region.

The competition between houses, and between their allied commoner lineages, would lead to the formation of a rival kingdom -- a separate power, the existence of which made the removal of chiefs more difficult, for chiefs could ally themselves with their King's rival. Only once the original rivals had died, and their generation among the political leaders had passed, could peace be made. Once this happened, the third and final stage would begin, with the removal of chiefs in Shambaai, and the achievement of the configuration of domination. The passage of time led to a breakdown in the sense of solidarity among chiefs. At the beginning of stage two (at the death of a dominating King), the chiefs were all half brothers, sons of a single man. They were accustomed to acting together, many had grown up together, and they were all of a single generation in the Kilindi lineage. With the passage of time, some chiefs died, and their sons, who had grown up in the provinces, became chiefs. Some men of the older generation survived, so

that the chiefs, after a period of time, were distributed over at least two generations. The King was able to remove chiefs of the younger generation without threatening those of the senior generation. This process of domination had taken place during the early years of Kimweri ye Nyumbai, and it seemed to be gradually occurring at the time of German conquest, in the early 1890's.

The way in which the cyclical pattern worked itself out depended, to a certain extent, on accidental, unpredictable occurrences. The King's position, after the death of Kimweri ye Nyumbai, was much weaker than it would have been had the son of the great house not died before his father.

The greatest problem with this cyclical interpretation is that we do not have a great many cycles as evidence. The Kilindi kingdom lasted for about a hundred and fifty years, there was one main lineage, and a full cycle took between fifty and a hundred years. The Kilindi lineage within Mshihwi, however, progressed through the cycle outlined here. There was one variation: the rival to the Mshihwi king did not found a separate kingdom, but instead went to live in the main Shambaa kingdom as a private citizen. He waited for a propitious moment, and then returned to drive out the king of Mshihwi.

## FOOTNOTES - CHAPTER FOUR

<sup>1</sup>This is a summary of data given in Feierman 1970: chapter iv.

<sup>2</sup>The quotation is taken from Feierman 1970: 123.

<sup>3</sup>I spoke to a descendant of Mkanka Mghanga about this incident. He was embarrassed and angry that I had learned of it, but confirmed that it had happened.

<sup>4</sup>The quotation is taken from Feierman 1970: 110.

<sup>5</sup>This was reported as a statement made after Shekulwavu's death to Shekulwavu's full brother. But my point about the way in which the situation is (and undoubtedly was) perceived is still supported by the quotation.

## CHAPTER FIVE

## ROYAL DEATH AND ACCESSION

The death of a King was followed by the most important set of rites associated with Shambaa kingship. The ritual gave order to the King's death and burial, suppressed public awareness of conflict over the succession, invested the successor with the attributes of a King, and expressed, in powerful symbols, the danger to which the Kingdom was subject.

I have never witnessed the death, or the installation, of a King. The most recent accession was in 1948, and it is unlikely that one will ever take place again. This study is based on the descriptions provided by fifteen informants, some consulted a number of times. They include Kimweri Mputa Magogo (King, 1948-1962), many King's Representatives of his and earlier reigns, and members of lineages which had special roles to play in the ceremonies. A number of informants described not only the rites they themselves had seen or performed, but also pre-colonial rites which had been described to them by men of an older generation. My informants had been instructed with some care, for they were the custodians of the rites.

I have attempted to reconstruct a picture of the rites as they existed in the late pre-colonial period, by comparing the descriptions given by my informants with others recorded in the last decade of the nineteenth and the first decade of the twentieth century. Most of the written descriptions are fragmentary, and are inadequate when taken by themselves as descriptions and interpretations of the rites. But they are invaluable as corroborative evidence when taken together with the oral accounts. An accession which took

place in 1895, for example, was described by both a District Officer, in a fragmentary written account (Storch 1895), and by one of my informants, who had witnessed the event as a young man. Reports of succession rites by Shambaa informants were recorded by LangHeinrich (1903) and Karasek (1923-1924). There is a brief account of burial and succession in one of the chiefdoms, written by Marko Kaniki (1903), one of the first literate Shambaa. The rites were similar to those for a king. The most complete description is by Abdallah bin Hemedi 'lAjemy (1962), who was court adviser to the eastern faction of the Kilindi during the wars of the 1870's and 1880's. He based his description on oral reports, and probably on observations of chiefly accession.

I have taken some care to describe, to the best of my ability, the rites as they existed in the third quarter of the nineteenth century, and I make no claims for the validity of this description for any earlier period. A close reading of the oral traditions describing the politics of succession in the late eighteenth and early nineteenth centuries has left me with the impression that the rites were essentially the same in the earlier period. This impression cannot be confirmed in any systematic manner.

## I

The prescribed actions which followed the death of a King were extremely complex because they included diverse sets of ritual and political actions. Because of this complexity, I propose to give here a bare description of the complete order of the actions. Only then will it be possible, in subsequent portions of this chapter, to determine the significance of each separate part of the action -- the burial, the separation of the new king from his competitors, the public dramatization of forces.

The King's death was treated as a secret (and the secret was poorly kept) for four days, while the court officials made arrangements for his burial, and for the installation of his successor. A public announcement that the King was ill cloaked the intense activity at the court. The King's wives heard that their husband was dead, but they were not allowed to weep, for they could not show that they knew.

In order to preserve the fiction, a man was placed in the King's bed, with the body, hidden by the covers. Cold water was poured over the body from time to time, to keep it fresh. One of the intimate court officials would enter the King's room, to inquire after his health, and the hidden man would moan, replying that he was ill. Some of my informants said that the King-surrogate was an ordinary man, chosen at random. Others maintained that he was a slave, who was given the title mkika mpeho upon being put into bed.\*

At the same time that the ordinary men of Vugha acted out the elaborate pretence, they privately discussed his death. Here is one informant's description of the contrast between private fact and public fiction:

People whisper to one another: 'My friend.'  
 'Yes.' 'The King is dead, and we have not yet  
 installed a new King.' The young children are  
 the ones who are deceived. Even the women are

---

\*Karasek maintained that the person in bed was one of the King's Representatives, either the Mbaruku or the Beeko. This is clearly not so, for these men had important decisions to make during the four day period. Also, many of my informants had been King's Representatives, and they disagreed. The precise meaning of mkika mpeho is unclear.

deceived by the man moaning in the King's bed. But the grown men all know that the King has died. Every man knows. The whole country is instructed: 'Don't tell! Don't tell!' 'If you say this, and if you are overheard, don't say that it was I who told you.'

The officials of Vugha sent men to a number of chiefdoms to collect livestock tribute for the expensive rites. The livestock was ostensibly to be used to pay medicine men for treating the King.

At the same time, the officials sent messengers to bring a number of Kilindi to Vugha, for a conference to advise on the selection of a new King. The Kilindi who were eligible to succeed -- usually the sons of the dead King -- were not informed of the conference, which was attended by the siblings of their father or of their father's father. These were the men whose hopes had been frustrated in earlier successions, and who were now the dominant elders of the Kilindi lineage. There was great variation, from one succession to the next in the political power of these men.

The eldest son of the King's Great Wife usually succeeded, but the succession was not automatic. The Kilindi advised the men of Vugha on the relative merits of the candidates, and especially about the support each candidate was likely to receive from the influential Kilindi after succession. The actual choice of the successor was made by the officials of Vugha, who sent messengers to bring the future King to the town of Bumbuli, in order to begin his rite of accession. The Chief Minister and the King's Representatives had the right to ignore the recommendations of the Kilindi, and to send for the man they preferred.

The successor, once summoned by the men of Vugha, chose his Great Wife, who was to arrive at Vugha shortly after the installation. Then his travelling party was assembled. It included his sister, and the officials of the royal household who had come to get him. They took along a cow and a goat from Bumbuli, so that the new King could give meat to the men of Vugha.

Mbegha, the founder of the kingdom, had travelled from Bumbuli to Vugha before being made King by the people of Vugha. The paths said to have been followed by Mbegha were remembered with precision and in great detail, so that each new King could walk in the footsteps of his ancestor. There was complete agreement among my informants on the paths followed by the new King, although there was some disagreement on how many nights the successor's trip took (for he travelled only at night), and on where the King slept along the way to Kihitu (near Vugha). My description of these latter details is thus a gloss on conflicting accounts.

The first part of the future King's trip was from Bumbuli through the Nango villages of Wena and Tekwa. The Nango of the Bumbuli region are said, by most knowledgeable Shambaa, to have been the mother's brothers of the King (see below, for the justification of this claim), and my informants described the rites which took place in the middle of the night at Tekwa as the blessing by the new King's mother's brothers, and the invocation of his maternal ancestors. First there was a Nango sacrificial rite, after which the headman of Tekwa seated the successor on a large stone, and said Hita mpeho ng'wanangu, 'Go coolly, my son.'\*

---

\*Abdallah bin Hemedi 'lAjemy gives a rather different description of this part of the rite (1962:Sura 48). It is possible that details which were known to him are no longer remembered, or are simply unknown to me. I have not given more weight to his description because it is rather elliptical, and because Abdallah himself never observed the rites. My own version is based on the description of the courtiers, as amplified by a Nango informant from Wena, and two Nango informants from Tekwa.

The successor left Tekwa before dawn, and walked on through the village of Zeba to Kihitu, a village about two miles east of Vugha, where he slept during the day, and where a major part of the rite of accession took place on the following night. The rites at Kihitu were described to me in some detail by a man who had witnessed the accession of Kinyashi in 1895. I give his description here:

Kinyashi entered Kihitu, and he slept there. He was made King at Kihitu . . . There is an mvumo tree with the ceremonial stone on which he and the Mdoe [non-Kilindi headman] of Kihitu sat. The Mdoe of Kihitu is the one who sat there first. The linga [royal headdress] was brought, and it was placed on the head of the Mdoe, with its ostrich feathers. While the Mdoe sat on the stone, Kinyashi was kneeling on the ground. A large billy goat was killed, and its breast meat was roasted, and cut into small pieces. . . . Kinyashi was given a piece of meat, which he held between his teeth, and passed on to the Mdoe, who ate it. When he finished, the Mdoe took some meat between his teeth, and gave it to Kinyashi with his mouth. When the Mdoe, who was still wearing the linga, had finished passing on the meat, he stood up, took Kinyashi by the arm, turned him around, and sat him on the stone. The Mdoe took the linga off his own head, and placed it on Kinyashi's head. The Mdoe then greeted the Kinyashi with his praise name, 'Simba Mwene' [the lion], and Kinyashi responded with the lion's growl. 'Eeee,' because he had taken on lion-hood. Kinyashi's sister now made the trilling cry Shambaa women make at times of joy: 'Yelelelelelelele!' Then they moved to another stone, a bit removed from the first. The Mdoe sat, and then he had Kinyashi sit. When Kinyashi arose, the people who were there greeted him, 'Simba Mwene.' 'Eeeee.'

This account is the most complete single description of the ceremonies at Kihitu. The descriptions by other informants support it in most details, and add a few which were omitted: most informants said that bananas were roasted with the meat. Two very knowledgeable men said that it was the Mdoe of Kihitu who supplied the goat (or alternatively a ram). Another informant said that the lion's skin was spread on the stone where the Mdoe and the successor sat. An invocation at Kihitu was described by only one informant -- an expert and reliable former Mbaruku (a King's Representative). Other informants explicitly denied that an invocation was made; the Mbaruku, as a King's Representative, did not take part himself in the ceremonies at Kihitu. The existence of the invocation would not, however, have changed the shape of the ritual significantly. I quote, here, the Mbaruku's description of it:

While the King was sitting on the stone, leaning his back against the mvumo, someone made an invocation: 'You Mbegha, you Bughe. We have given birth to a King, and here he is. The King has died. We have given birth to a King. ' . . . .  
 [Bits of roasted bananas and meat were then wrapped in banana leaves, in two separate packets, which were left on the stone.]

At the same time that one group of officials was accompanying the new King from Bumbuli to Vugha, another group was preparing for the burial of the old King. First the officials at Vugha removed a part of the dead King's

body, which was to be dried, and then used as part of an assemblage of rain charms by the new King. No one at Vugha was willing to tell me what part of the King's body was used. In fact, only the former King mentioned its existence to me; all the other former officials felt that they had no right to mention a secret of this importance.

It is an essential characteristic of the rites of succession that the burial of the old King took place at the same time the new King was given the royal headdress at Kihitu. On the fourth night after the King's death, which I have taken to be the second night of the successor's progress from Bumbuli, the old King was buried, and the new King was acclaimed, so that the Shambaa lost a King and gained a King in a single night.

The King's Representatives, with some of the trusted men of Vugha, entered the royal burial enclosure, in secret, in the middle of the night, and dug a deep grave. The King's corpse was then brought secretly from the Great House. A black bull and a black ram were killed at the burial enclosure, and some of the meat was cooked (probably roasted) and eaten.

There is considerable disagreement about what happened next, partly because the next step involved the use of at least one slave, perhaps two, and therefore none of my informants had witnessed the practice in question. Most of them said that the mkika mpeho, the man who had been moaning in the dead King's bed, was put into the grave to make sure that it was the right size. Karasek's informant, in the first decade of the twentieth century, said that a male slave stood at the head of the grave, and a female slave at the foot (1923-1924:20). Both Abdallah and Marko Kaniki wrote that a man and woman, of slave status, were made to lie together in the grave. The confusion does not end here. Some of my informants maintained that the mkika mp

was killed, and his body placed in the grave with the dead King. But the most knowledgeable of them argued that the mkika mpeho had earned his freedom through his services, and was required to leave Vugha. Indeed Karasek reported that he had seen his Shambaa mistress, Makihio, buy some maize from a person at a market. A friend then warned Makihio that she had bought from someone who had been in the grave of a King. Makihio threw away the maize in horror, explaining to Karasek that anyone who ate it would die. It is certain, from all reports, that at least one person was killed, either at the grave site during the burial, or on the paths near Vugha later, and that those who described the death of the mkika mpeho combined two actions which were in reality separate ones -- the placing of a slave in the grave, and the murder of a subject.

After measuring the grave, the officials of Vugha placed the skin of the sheep they had just slaughtered in it, so that the King should not lie on the bare earth. The blade of a hoe, which had been forged that night and was covered with carbon, was placed where the King's head would rest (and later taken out again). According to Karasek and Abdallah, but no other writer and none of my informants, a black cat was placed in the grave.

Then the body of the King, wrapped in black cloth was lowered into the grave. The bull's hide was used to cover the body, then large stones were used to cover the inner grave hole, and earth was filled in over them.

(See p.25 for a description of the grave, and its place in the capital.) The King's Representatives, having buried the King, went to a spot near the village of Fune, a short distance to the east of the capital, to await the arrival of his successor. They killed and cooked a sheep or goat, and ate while waiting.

At about this time, still during the fourth night after the old King's death, the successor left Kihitu, where he had been given the headdress, and walked westwards along the prescribed path towards the spot where the King's Representatives were waiting. First, he passed Kawe Nkajatwa, literally, 'the stone which is not stepped upon.' This stone, which had ostensibly been stepped upon by Mbegha, remained covered by undergrowth and inaccessible at all times except during the accession of a King, for which it was cleared. The new King proceeded past the villages of Kigongo and Sakua, and across the Nkozoi stream to the village of Fune.

At Fune, the officials accompanying the King killed the bull they had brought along from Bumbuli, built a fire, and began to cook. They laid the King on the ground, <sup>and</sup> covered him with a cloth. The King's Representatives, having seen the fire, came to eat. They grabbed and tore at the meat of the bull. Then, in the words of one informant, 'they stole the King.' They wandered about aimlessly, carrying him. Then one of them, the Mdoembazi, carried the King across the stream which ran near Fune. The men who had come all the way from Bumbuli with the successor were left behind, their charge having been stolen from them. The new King, meanwhile, was taken to the house of the Mdoembazi, on the east side of Vugha, where he slept until dawn.\*

---

\*According to Abdallah, the new King invoked the ancestors at the burial enclosure, and a bull was sacrificed (1962: Sura 60). No other writer or informant agreed with this.

The timing of these actions is crucial to an understanding of the rites. During the fourth night the old King was buried, the new one acclaimed at Kihitu and then passed on from one set of officials to another at Fune. At the dawn which would end this eventful night, the war drum Nenkondo would be beaten to indicate the death of a King, and also to summon the people of Vugha to see his successor.

When the sky was beginning to redden, the new King was led to the Council Clearing in the royal court. The drum was taken out of the Great House, it was beaten, and its skin was cut with a knife. According to Karasek, a horn (gunda) was blown at the same time, and the hoe which had been in the grave was beaten. When the people of Vugha swarmed out in response to the war drum, they came upon the new King, already in the clearing of his court.

Then came the public recognition of the new King, in the form of the event called kuikia nkani -- 'the dramatization of forces,' in which the tensions between King and commoners, and between King and councillors, were acted out. (The translation of the term is discussed on p. 236 ). The people of Vugha shouted, 'You are our King, but if you don't treat us properly, we will get rid of you.' 'Give us rain! Give us bananas!' 'The country is yours, and the people must have their stomachs filled.' While they were saying this, the King was sitting on one of the stones in the clearing, wearing his headdress. Then the Mlughu, the Chief Minister, stood before the crowd, held a double-edged sword in the air and called out, 'Eh! Eh! Eh! Eh! Eh! Eh!' In response, the people called, 'Mkaa, mkaa, mkaa, mkaa,' 'the hunter, the hunter, the hunter, the hunter.' Then the Mlughu gave the sword to the King, who arose, and called out as the Mlughu

had done. The people responded, 'Mbogho, mbogho, mbogho, mbogho,' 'the buffalo, the buffalo, the buffalo, the buffalo.' The gunda, the horn of a bushbuck, was sounded, and the people of Vugha continued to call out the set phrases which were used on this occasion:

Kakuli mighendo, mpalahole: 'The small dog walks slowly.'

Leka ni muiyego, leka ni muiyego. Uetighwa ni msembwe.  
Msembwe ni muungu: 'Wait, it is powerful. Wait, it is powerful. It was brought by deceit. The deceit is God.'

Ieziezi. Mwe nyika hakuna kdeghe, kdeghe ni nye: 'Down in the plains there are no birds, the small bird is silent:

Haviongwa, haviongwa, haviongwa: 'It is not mentioned, it is not mentioned, it is not mentioned.'

Eee ni muungu ee: 'Eee, he is God, eee.'

Zizimiza, zizimiza: 'Endure it, endure it.'

With the dramatization of forces, the installation ended. But the period of mourning began only at this point: only once the country had a King was it able to mourn the death of a King. During the period of the mourning, the four main paths leading from Vugha in the cardinal directions were closed. Anyone who walked on them would be killed. The mshangi, of the lineage which performed ritual murders for the King; went to a spot at Kwe Mishihwi where a boulder stands in the middle of a path, which separates to pass above and below it. At this spot, he strangled a passerby. (The time of this occurrence is unclear. It may have taken place while the successor was coming from Bumbuli.) Acts of violence were permitted during the mourning, and men walked the paths only in groups. The people of the Kingdom did not cut their hair, and men did not shave. No rites of passage or sacrificial rites

were permitted. No farming was done until the mourning had ended.\*

Immediately after the drum was beaten, the Mbugu of the central highlands of Shambaai, who were tributaries of the Shambaa King, sent representatives of all their communities with livestock tribute.

At the same time, Kilindi chiefs from all over Shambaai converged on Vugha to arrange for the inheritance of the dead King's wives. A widow could only be inherited by a lineage member of the dead man's own generation, or of his grandson's generation (see Chapter ii ). Since the new King was most often a son of the one who had just died, he could not inherit any of the widows. The Kilindi settled the inheritance of the Great Wife carefully, for she was now the mother of the King. Her heir would have influence at Vugha, and he would be the spokesman at the capital for the royals of his own generation. The other wives were taken during a brawl, in which every Kilindi grabbed for the nearest woman, although fathers of some of the women arranged in advance for their daughters to be taken by particular chiefs. The wealth (mai) of the old King -- his cloth, guns, and livestock -- was passed on undivided to his successor, immediately after the dramatization of forces.

The inheritance of the dead King's wives and goods took only a few days, but the mourning continued up to a month, until the waning of the moon under which he had died (LangHeinrich 1903:251). At the end of this time the men of the royal court took beer, bananas, and a billy goat to the Burial

---

\*One of my informants said that no farming was permitted from the time of the old King's death. The prohibition could be made without breaking the secrecy, because there was a magical ceremony for agricultural fertility (hande) in which the people of the land were prohibited from farming for four days.

Enclosure. The dead King was invoked, together with all the royal ancestors, while beer was poured on the grave. Then the successor took the goat by the right ear, and made an invocation: 'May all of you sleep. May our children live and may we all eat meat. Give us rain. Sleep.' The goat was killed, its meat was roasted with bananas, and the mourning was ended.

Before going on to <sup>an</sup> analysis of the rites, I would like to return briefly to the problem of sources. This rite (or series of rites) differed from other Shambaa rites of passage in that there were no initiated adepts to teach the rite to the novice. A King was installed only after the old King had died, following the principle that for the King of Vugha, kubushwa ni kufa: 'the only abdication is death.' The ritual knowledge was entrusted to commoners, who by instructing the successor, and performing the rites, made him King.

No single individual, however, commoner or Kilindi, ever saw the entire sequence of rites as described above. The King's Representatives were burying one King at the capital while the headman of Kihitu, with some members of the royal household, was installing the successor. To each group, the rites performed by the other remained hidden. When the new King was carried across the stream at Fune, he was passed on from one group of officials to the next. In addition, the rites performed at Tekwa, near Bumbuli, were preserved in detail by the Nango lineage of that village. Even the King had only partial knowledge: he never saw the care of his predecessor's body, and its burial.

One result of the fragmented transmission of the rites, is that any given individual, whether ordinary subject of Vugha, King's Representative,

headman of Kihitu, or the King himself, describes only a portion of the rites in detail. The ordinary men of Vugha, when asked about accession, usually describe the dramatization of forces. The Nango describe the successor's trip from Bumbuli through Wena and Tekwa in great detail, but then omit any descriptions of the events at Kihitu. The King's Representatives describe the burial in detail, and then the arrival of the successor at Fune.

This means that the description given above is reconstructed from a number of detailed fragments. No individual informant described the entire series of events in detail. The written sources are even more fragmentary than the oral ones. The fact that the accession and the burial took place at the same time was explained clearly only by the most expert of the informants. The man who was clearest and most coherent in his description of the relationships between the separate actions was the head of the lineage of the hereditary Chief Minister, who came closest to being a coordinator of the total event in practice. I have two reasons for accepting the statements that burial and accession took place at the same time. Firstly, the men who described the actions as simultaneous are extremely knowledgeable. Secondly, according to most descriptions of the burial, the drum called Nenkondo was beaten and slit to signal the completion of the burial; according to most descriptions of the accession, Nenkondo was beaten and slit to signal the arrival of the new King. Both descriptions are acceptable, once it is understood that the new King arrived in Vugha on the same night as the burial. In addition, the death of the King was not publicly acknowledged until his successor had been installed.

## II

The most important images, in the burial and mourning of the King, were images of danger. The death of a commoner among the Shambaa led to a period of heightened risk for his dependents, but the death of the King led to a period of danger for the whole of the Shambaa Kingdom, as will be shown below. The special danger of the King's death was expressed in the modification of ordinary burial and mourning practices. The modifications described below apply not only to a King, but to any Kilindi chief, the only difference being that in the former case the entire Kingdom mourned, in the latter a single chiefdom.

The King's burial was characterized by blackness. The dead King was wrapped in a black cloth (kaniki, or beghe), while dead commoners were wrapped in a white cloth (shanda).<sup>1</sup> The King was buried in the blackness of night, in secrecy, while most commoners were buried in the daytime, with the greatest possible public participation. The hoe which was placed in the King's grave was a new one, which had been wrought at night, just before the burial, and which was covered with carbon. In all the descriptions, the hoe is called kiama che mshizi, a carbon covered piece of metal. Carbon is used to make black markings on the bodies of gao (young men) initiates (with red clay for red markings, and chalk for white). The cow and the sheep killed at the King's grave were both black. And according to some early accounts a black cat wrapped in a black cloth was put in the grave.

Black (-chuta), white (-ng'aa), and red (-unguika), are the only colours expressed as verbs in the Shambaa language. Thus one would say, shuke yachuta, 'the cloth blackens,' or zuwa jaunguika, 'the sun reddens.' These are the only three colours which are treated as abstractions with no single concrete referent. All other colours are named after things,

and are treated as nouns or adjectives. Thus, one says rangi ya mani, 'the colour of grass,' for green.

There was one Kilindi who, when asked why all the black things were used in the burial, explained, 'A person who has ukai (sharpness) blackens.' The quality ukai (or ukali) is quite often associated with blackness. -Kai means sharp, dangerous, brave, reckless. One uses it to describe sharp peppers, a sharp hunger or thirst, the leader of a war party (mkai wa nkondo, literally 'the sharp or fierce one of war'), or a violent King. One old man was trying to explain to me why the Shambaa welcomed Mbegha, and why Mbegha's descendants continued to rule Shambaai even though they were not as peaceful as their ancestor. He contrasted the term -hozu, meaning peaceful, calm, with -kai. 'Mbegha was a peaceful man. He had no enemy. But later Kimweri [Maguvu] was different. Some people wanted to kill him, but they could not because he was too fierce (-kai).' According to a proverb Ya mwogha yaingiza usheko, ya mkai yaingiza ndio -- 'timidity leads to laughter, ukai leads to mourning.'

The association between blackness or darkness and bravery or danger is found in a number of other contexts. There is the proverb, Kui zize hejiogoha mziwui: 'the dark dog is not afraid of the forest.' Another proverb explains, Ushingieho hana wiza: 'the place you have never been remains in darkness.' In the pre-colonial and early colonial periods black cats and black snakes were associated with dangerous spirits, and sacrifices were made to them.

The darkness of the night in which the burial took place was expressive of danger, like the black artifacts. One informant explained, when describing the accession: 'A man is like a lion. The night is his.' This meant that

a man (as opposed to a woman) is a dangerous creature, who preys at night. The same informant also said:

Night is danger. The king rules at night. He does not sleep . . . . At three in the afternoon he sleeps . . . . He goes to the Mlughu deep in the night. 'Wake up the bachelors, and tell them to go and see what is happening.' When they get to the place, there are people drinking beer. They say, 'All right, this is harmless.'

I was told not to drink beer at a sacrificial rite, because people are more likely to poison one another at night.

The new King's trip and the old King's burial took place at night, but the drum was beaten, according to most of the reports, kukiunguika -- when the sky reddened on its way to lightness. In the major sacrificial rite of all Shambaa lineages, the sacrifice of the clinking bell (fika ya chekecheke), the actual sacrifice, and the departure of the dangerous spirit (months or years after death) takes place when the sky reddens at dawn.<sup>2</sup>

Many elements of the burial and mourning were strikingly similar to the magical ceremony called hande, which was performed to restore the fertility of the land, when a crop failure seemed imminent. The following description, by a hereditary hande specialist, gives further evidence on the meaning of blackness, as well as a parallel to the prohibition on farming during the mourning:

I use a black cloth, and a black chicken, a carbon covered metal, and a black sheep. I invoke my ancestors [who made this ceremony before me.] I cover myself over with the cloth, and mix herbs with the sheep's stomach contents. The metal is for mixing the medicine. It is hande of food. Then the children go to all the gardens with a gourd full of the medicine, and sticks to poke into the ground. They do this

for four days [during which no one may farm.] When the four days have passed, all the people make a communal farming party for the man who brought the medicine man, whether it is the chief or an ordinary person. . . . A person may wish that the land be devastated, so that people move away, for then he will get more land. He sends vermin, or he stops the rain from falling, or he sends locusts. Or he may send rats, to eat all the maize. Our job is to cool the land [that is to remove the effects of the man's charms.] But it is not our job to make the rain fall every day. It is to perform the ritual in the way our ancestors did, so that the land will be left alone. The man who makes sorcery uses charms which are black, and that is why the counter-charms must be intensely black. Then all his charms become harmless. They have died. The one who made the sorcery [by mixing earth with the herbs] has not used the contents of a sheep's stomach [which is a very commonly used cooling agent], and you, by adding those contents to the medicines used, have cooled them.

There are several points of importance here for a study of the burial and the mourning of the King. First, the charms which destroy the fertility of the land are black; the charms used in the counter-magic must be 'intensely black,' and they must be made in darkness, under a black cloth.<sup>3</sup> Second, in the hande, as in the mourning, the people of the affected region had to desist from farming for a prescribed period, and then begin together. In both cases the land was defiled: in one, by the blackness of the King's death; in the other, by the blackness of the harmful charms. The hande interval, like the interval between the death and burial of the King, was four days, the length of a market cycle, and something like a Shambaa week. The farming prohibition after the King's death lasted until the moon waned and the first slim crescent appeared.

A survey of the other mourning practices supports the view that the mourning period was one of pollution and danger, and that the prohibition on farming led to a separation between the period of pollution, and the period in which the normal processes of reproduction and growth could follow

their natural unimpeded course.

For the duration of the mourning, no one could have his hair cut, and no man could shave. These prohibitions are observed during the mourning ceremonies of any Shambaa. The only difference in this case is that the whole land mourns. At the end of the mourning ceremonies, the important mourners, who have let their hair grow, have their heads shaved, and are then allowed to return to their everyday concerns. Hair is seen as a particularly dangerous kind of dirt. One man told me that if you put hair in someone's drink, he will die. Hair is also associated with ritual power. In the pre-colonial period, a medicine man would grow a long lock of hair on the top of his head, as a symbol of his power.

The danger of the mourning period was not merely symbolic. As shown above, there was violence on the paths, and at least one commoner was strangled. According to Abdallah bin Hemedi 'lAjjemy, the death of a King was followed by warfare against the enemies of Vugha, as part of the mourning (1962: Suras 40, 69). Krapf, writing from the coast at the time of Kimweri ye Nyumbai's death, reported that it was 'incumbent on the new ruler to make a warlike expedition against any real or fancied enemy, in order to capture a few hundred people, and sprinkle their blood upon the grave of the late king' (1863: 300).

The people of Vugha say that commoners were killed because 'the King should not die alone.' But this is not associated with any concrete image of the King passing with his servants to the spirit world. The killing of subjects was the most concrete and effective way of representing the dangers to which the land was exposed during the period of transition after the King's death. There was one other occasion on which a person was

killed as part of a ceremony: this was during the young men's initiation (gao), as practiced by the Kilindi. There is a crucial point in the gao, at which the young men go to a marshy area, just before having their heads shaved to remove the dirt of gao, when they are passing from the status of novices. A brass bracelet is placed in a chalk bottomed pool, and each initiate must put his head into the water, and take the bracelet out with his teeth. The song which is sung while this goes on is:

Kuzimu ni kwedi  
Kuiha mighendo

The spirit world is beautiful,  
Only the trip is frightening.

It is said that when the King made gao for his sons, the pool was dammed up with the body of a man killed for the purpose. The young Kilindi, who would grow up to have the greatest ritual power, were taught in the most concrete way possible that ritual power kills.

There is a further point. The death of so powerful a man was certain to be followed by a period of danger for the entire land, in the same way that the death of a commoner led to a period of danger for his dependents. The mourning period, with its disorder, enabled the Shambaa to contain the danger within a discrete period, and to ensure that the danger would be directed against foreigners and against the weak, rather than against all Shambaa, as in a famine. There is evidence for the way the mourning period was thought to limit the danger, in the Shambaa response to the death of Kimweri Maguvu in 1893, and of Mputa in 1895. These were the first two Kings to die after German conquest, and therefore these were the first royal deaths in Shambaa experience which were not followed by periods of intentional disorder. In January 1895, about a year after Kimweri Maguvu's

death, swarms of locusts came to Shambaa, and ate most of the crops standing in the fields. The people of Mlalo told the local missionaries that Maguvu's father had sent the locusts as mourning for his son's death. In April, Maguvu's successor Mputa died, and on May 15 there was an earthquake with three blows, which the Shambaa of Mtai believed to be the natural consequence of Mputa's death.<sup>4</sup>

### III

The new King was one of a large number of siblings and half-siblings who, according to the ideology of descent, were more or less equal to one another. One effect of the rite of accession was to separate one individual from among his siblings, and make him not merely first among equals, but King, acting a role which was qualitatively different from that of any other Kilindi.

The rule of succession clearly isolated a single individual as the legitimate successor; if the rule had been adhered to at all times, there would never have been a political dispute on the choice of an heir. At the time the old King had acceded, he had chosen a Great Wife, whose eldest son was called 'the Child of the Great House' (ng'wana nyumba nkuu). The Great Wife bore the heir on the skin of a lion said to have been killed by the hunter Mbegha at Kihitu, immediately before Mbegha had become first King of the Shambaa.\* Thus the new King, when he took on his lion-like qualities

---

\*It is not clear what happened if a girl was born on the lion's skin. Abdallah bin Hemedi 'lAjemy wrote that if the first child of the Great Wife was a girl, the infant was killed.

during the accession, was merely fulfilling the destiny to which he had been born on the lion's skin.

In reality, the successor was chosen for his personal qualities, and because of the importance of his supporters among the Kilindi, and among commoner lineages. If he happened to be the Child of the Great House, so much the better. If he was not, his mother might be elevated retrospectively to the status of Great Wife. In the late nineteenth century, when the son of Semboja became king, and all Shambaai knew that Semboja had not been of the Great House, it was stated that Semboja's father, Kimweri ye Nyumbai, had had two Great Wives, Okimea (the usual name for a Great Wife of the Kimweri generation), and Semboja's mother Oshimba.

If the proper heir was not old enough at the time of the King's death, then a brother of the King succeeded, to be followed after his death by the heir, who had presumably grown mature by this time.

The final decision was in the hands of the King's Representatives, together with the Chief Minister. These officials were particularly well suited to choose the candidate most likely to establish strong centralized rule, for the stronger the King, the more the wealth and power of the Vugha officials grew (as will be shown in the chapter on warfare, litigation, and tribute). This means that the mechanism of choice could remain relatively constant through periods of rapid political change, for the Vugha officials, when making their choice, considered the realities of the distribution of power at any one time. In the eighteenth century, they tended to choose the candidate with the strongest support from the powerful semi-independent clans and large lineages. In the late nineteenth century, they consulted the great traders. But in each case, they sought to maximize the authority of the King of Vugha. (For a fuller discussion of political competition

during and after succession, see chapter iv ).

The officials made the final decision by sending messengers to bring the successor to Bumbuli, to start going through the rite of accession. The first part of that rite was the trip from Bumbuli to Vugha, along the paths which had been taken by the founding king Mbegha. The imitation of Mbegha was one of the most important ways in which the successor took on king-like qualities, and therefore I shall examine it in detail.

A full analysis of the Mbegha myth has been made elsewhere (Feierman 1970). It is necessary only to recount its bare outline here. Mbegha was a hunter with dogs in Ngulu, to the south of Shambaai. He was driven out of his home because he was a dangerous person. Some versions maintain that Mbegha was a kigego -- someone born in an abnormal way, who causes death in his own lineage (see p.72 ). Other versions describe the hunter as an adulterer. After he was driven out of Ngulu, he travelled through the plains with his dogs, hunting and eating meat. The people of Ziai, in southern Shambaai, saw him, and they received gifts of meat from Mbegha. In return, they gave vegetable products. Mbegha was especially proficient at hunting wild pigs, and so he was taken to Bumbuli, where pigs were destroying the crops. He was taken to Vugha to kill the wild pigs there. He gave away meat, received plant products, and was given wives. At Kihitu, near Vugha, Mbegha killed a lion which was threatening the livestock in the night. Upon killing the lion, he became the Lion King (Simba Mwene), and his agnatic descendants were the Kilindi.

Many elements of the rites become comprehensible as reenactments of Mbegha's deeds, or illustrations of Mbegha's qualities. Thus the successor

took with him, from Bumbuli, a bull and a goat. Even though the successor did not demonstrate his prowess as a hunter to the men of Vugha, he provided meat, just as Mbegha had done. The court officials at Fune tore and grabbed at the meat of the bull, showing the greed for meat that had led an earlier generation of Vugha men to make Mbegha King.

Along the route from Bumbuli to Vugha, the successor reaffirmed the historic alliances of Mbegha. The informants say that at Tekwa, the most important stop, the heir received the blessing of his mother's brother, as this relationship with the Nango of Tekwa was continued from the time of Mbegha. There are numerous difficulties to this interpretation. It is clear, from the historical traditions, that the Nango alliances were not made by Mbegha, but by his son Bughe (Feierman 1970: Chapter Three). In addition, the Nango who hold Tekwa today replaced a different lineage of Nango during the first half of the nineteenth century, although both lineages were of the Mvina Nkima sub-clan. Finally, there has been no instance of a King taking his Great Wife from Tekwa since the second half of the eighteenth century. The informants did not deny the weakness of the actual Tekwa alliance. One man said: the successor stops at Tekwa 'in order to have a sacrifice made to the ancestors of his mother's brother, so that he goes with his mother's brother's blessing. But the head of Tekwa is not his mother's brother. It was simply placed like that at the rites.'

Why, then, did the successor stop at Tekwa? The Nango clan was the most powerful group which did not accept Mbegha's rule during the early years of the Kingdom. Mbegha's son made an alliance with the men of the Mvina Nkima lineage; this alliance led to decline of independent Nango power, and the creation of a much more unified Kingdom within Shambaa than

had existed previously.\* At the beginning of the nineteenth century, the Nango alliance must have seemed one of the fundamental institutional arrangements of the Kingdom. Many of the fundamental arrangements of the Kingdom were attributed to Mbegha, because he had been the first King. In the late nineteenth century, as the Nango declined in importance, the meaning of the rites at Tekwa must have changed. Although the Nango were in decline, the most honoured allies of the King (or chiefs) were related to him through marriage or as members of the category 'mother's brother.' The alliances themselves derived their strength from their variability: the King could make alliances wherever they would contribute the most towards his support. But the rite of accession was not variable, and so the Nango of Tekwa took the place of generalized mothers' brothers to the successor.

There was a second form of alliance when the Mdoe of Kihitu exchanged meat with the successor, by mouth. One informant explained: 'The Mdoe swallowed the successor's saliva. It is blood partnership.' This was both a re-enactment of the deeds of Mbegha (who built his kingdom by making alliances), and the creation of a new alliance between the successor and the headman of Kihitu. The case is similar to that of Tekwa, for the Mdoe of Kihitu in recent times was not related in any way to the original headman, of Mbegha's time.

The next step in the imitation of Mbegha was the acclamation of the successor at Kihitu as Simba Mwene, for it was in this village that Mbegha

---

\*The detailed data for these statements is given in Feierman, 1970. See also chapter ii , above.

was said to have killed a lion, and had therefore been acclaimed as Simba Mwene.

At Fune, where the Mdoembazi came upon the successor lying upon the ground, covered with a cloth, picked him up and carried him across the stream, elements of the Mbegha myth were being recapitulated. The important elements in this action, according to all the informants who discussed it, were those of secrecy, and of the King's complete passivity. One notable explained: 'The King resembles a bride who has just been taken in elopement. The next day people are taken aback when they see him [in his new status]. He is like a woman. He acquires his power only once he has entered the royal court. The people of Vugha are taken aback to see that there is a King, but he is not the same one they have known all along.' Just as the men of Vugha had made Mbegha King by their own free decision, they now made the successor King. He was powerless until they installed him. In describing the action at Fune, the court officials say that the new King was 'stolen.'

The imitation of Mbegha, in the rite of accession, established a special relationship between the successor and his ancestor. Mbegha's personal qualities had inspired respect and awe, according to the myth. Mbegha had been so king-like that he had been made King. He had had the power to clear the land of wild pigs, and to increase the fertility of the land, as well as the power to cause death, for he had been driven out of Ngulu because he had been born abnormally, and had caused death in his lineage. Mbegha's powers, his charisma, had come down to the living through lines of descent, and should therefore have been equally accessible to all living Kilindi: to all the agnatic descendants of Mbegha. The new King, by

reenacting the deeds of Mbegha, became more intimately associated with the hero King than any of his agnates.

In addition to his imitation of Mbegha, there was one further action of the successor which separated him from his competitors, and made him less vulnerable. This was the action at Kihitu in which the new King was seated on a large stone. One very old man who lived near Kihitu explained to me that the stone was a protective charm. He said:

When the King sits on the stone, he is transformed by medicines. His body is transformed when he sits on it . . . his body has become hard like the stone . . . His body is like stone.

This is very similar to the use made of stone in protective charms (kagho, pl. makagho) in ordinary (non-royal) Shambaa magic. There is one kind of kagho into which stone scrapings are mixed. The spell uttered by the magician emphasizes that just as a foot, walking on a boulder, cannot penetrate the stone, so will the protected person's body remain impenetrable to sorcery.

#### IV

The event which was called kuikia nkani, in which the people of Vugha shouted set phrases at the new king, was a great dramatic event, a piece of pageantry with blaring horns and shouting mobs, which stirred the emotions of the participants. Men who took part in such an event remember it with great excitement.

Nkani is a rich word, with a wide range of meaning. It means rebellion, or resistance. More generally, it means unjustified violence. I have heard men, when talking of a person who often gets into violent arguments, say, ana nkani: 'he has nkani.' The word also means tension, or striving, as in

the proverb, ngoe nkani, uta nkani (LangHeinrich 1921): literally, the string nkani, the bow nkani. More loosely rendered this means, when the string is drawn the bow resists, or the tension of the bow counters the tension of the string. Kuikia nkani means to make tension, or to make resistance.

An examination of the action itself will show that the most appropriate translation for kuikia nkani is 'the dramatization of forces.' The king, his councillors, and the common people of Vugha acted out their relationships to one another. I feel it would be inappropriate to call this action 'the ritual of rebellion,' or 'the reviling of the King,' because action included the public declaration that the king was the most powerful of all men. But it also included open statements of the deadly tension between the king and his councillors, and between the king and the commoners. The feeling of excitement which is associated with nkani appears to have been a result of its lack of restraint in dramatizing the forces. The most commonly used word for the quality of political activity among the Shambaa is 'deceit.' Men hid their intentions. The plot which was discussed openly was the unimportant one. To this day, many men, when going on trips, publicly announce false destinations. It has been shown that men hid their cattle, as a matter of course, in order to limit the depredations of the chief ( see p. 42 ). When so much was hidden it must have been enormously exciting, in the dramatization of forces, for the common people to announce publicly, that 'if you do not bring rain we will get rid of you.'

Some of the most important phrases in nkani used animal symbols to make statements about the content of political relationships. The new King was greeted as a buffalo, and addressed with a set phrase comparing him to a small dog. His coming was announced by the blowing of a bushbuck horn. The references

to animals in the nkani can only be understood in relation to one another, and with reference to more general animal categories. For this reason, the image of the King as a lion, which was not part of nkani at all, but part of the action at Kihitu, will be considered here.

Animal categories, as they related to the accession, are difficult to study in Shambaai today, because Muslim and European ideas have been superimposed on Shambaa notions. Thus rat-like rodents and pigs, which were commonly eaten eighty years ago, are rejected as food today. Nevertheless, with the help of written sources, the memories of old men, and observations in areas like Mshihwi where alien ideas have the least impact, it is possible to determine what the animal categories probably were during the late pre-colonial period.

A sharp distinction was made between animals which eat meat, and those which eat only plants. Herbivorous animals, which resembled the domestic animals raised for meat, could be eaten; carnivorous animals could not. Because of this distinction, creatures which look very much alike to outsiders were put in opposed categories. One kind of monkey, for example, the mbegha (Colobus palliatus), was eaten by the Shambaa; all others were prohibited. The Colobus is the only genus of monkey in the area which is purely herbivorous (Walker 1964 : I, 468). It is thought that anyone who eats prohibited meat will break out in open sores (-umbuka), the most extreme form of which is leprosy.

At Kihitu the King was called Simba Mwene, which compared him to a lion, and this remained his most important title through his reign. Quite remarkably, this title is not in the Shambaa language. A lion in Shambaa is shimba, not simba. Mwene is used by Shambaa commoners as an honorific

greeting, but it has no identifiable meaning. The reason for this alien usage is probably historical. The title was probably borrowed from the peoples of the Bagamoyo hinterland. The Doe people, who have traditions of having fought the Shambaa, use mwene as the title of a chief. Simba Mwene was a chiefly title in southern Zigula, where otherwise the name of the lion was never pronounced, for fear of drawing one near. Instead, a lion was called nyama kulu, 'great beast,' or mwenye nchi, 'possessor of the land,' which was also (as ng'wenye shi) one of the titles of the Shambaa King (Picarda 1886: 185, 227; Stanley 1872: 115-117).

The Shambaa understand that simba means lion, and they explicitly compare their King to a lion in several ways. The King was seen as a beast of prey because he had the right to sentence his subjects to death. One tradition, about how King Mputa sentenced a subject to death (in 1895), describes him as 'a lion which seized a cow.' Since the lion is a carnivore, its meat is not eaten, and so lions are not hunted in the plains. Lions do not normally live in the mountains, but when an occasional lion strays into Shambaa it is able to eat cows and goats until it is killed. Thus lions are hunted not for food, but in defense of wealth and homestead. Lion hunting is much like warfare. There is also an explicit comparison between the lion's ability to seize cows, virtually at will, and the King's right to take livestock tribute.

In addition, the power of a great hunter, which every King was thought to be, was similar to the power of a lion. I know one man who is a famous hunter, and who is said to have killed a lion with a machet. It is said that after the lion died, the hunter roasted and ate its heart. Any ordinary man would have been broken out in sores from eating lion meat, but the hunter was thought to have gained even greater powers by this polluting act.

The notion that the King, as a hunter, was a carnivore, helps to explain why the sacrifices associated with the succession (and other sacrifices associated with kingship) involved the roasting of meat, while in ordinary sacrifices, cooked meat is used. Roasted meat is described as 'raw' (mbishi), while boiled meat is 'cooked' (mbizu). The lion eats raw meat, and hunters in the plains used to roast bits of a newly killed animal and eat them before carrying the meat home to be cooked (Karasek 1913:90).

The death of the old King and the dramatization of forces for the new one were announced by the blowing of the gunda, the spiral horn of a bushbuck (nkuungu, Tragelaphus scriptus massaicus [Allen and Loveridge 1927:440]). I am paying special attention to what may be merely a signal, and not a significant part of the action, because the Kilindi have a special prohibition against eating bushbuck meat. No Kilindi I have asked has ever been able to give a reason for this prohibition. One man, a Christian pastor of the Kijelwa lineage, which has the same prohibition, gave the following explanation:

My father told me about the Kijelwa lineage in times of old, and said that in those days we did not eat bushbuck, because in time of war against the Taita, the Kijelwa used to turn into bushbucks. When the enemy saw the bushbucks they would go home, for they were looking for people. It came about one day that we were eating the meat of a bushbuck, and I asked my father, 'How come we eat it now?' Then he said, 'You know we are Christians. We don't become bushbucks these days, we people.'

Perhaps the bushbuck's adeptness at going through long stretches of interwoven vines and shrubbery (described by Walker 1964 :II, 1414) made it particularly appropriate for war magic. A second possible explanation is provided by the belief of the Bondei, who are very closely related to the Shambaa in language

and culture, that lions do not eat bushbuck (Dammann 1938:302).\*

When the King stood before the people with his Mlughu, the Mlughu was greeted as 'the hunter' (mkaa), and the King was greeted as 'the buffalo' (mbogho). This is a comparison which is only made, so far as I know, in the dramatization of forces, and it is an unusual one. The King, as has been shown, was usually likened to a hunter, and to carnivores, while here he was opposed to a hunter, and likened to a herbivore. The buffalo, however, is regarded by Shambaa hunters as the most dangerous of all game animals. When hunting was still an important economic pursuit, hunters would go out in twos to hunt any animal but the buffalo, which was hunted by groups of four to six (Karasek 1913:89).

---

\*There is an additional Kilindi prohibition against eating nkube (mole rats? moles?) which tunnel under the earth. I have not been able to find any particular reason for this prohibition. The moles are herbivorous, they make a sound like a smith hammering (nde nde), and it seems to eat earth but really eats roots plants.

The quotations which follow are explanations by several different courtiers of the paired symbols buffalo-hunter, as used in the dramatization of forces. The variations between the interpretations illuminate the range of connotations.

When you see the hunter and the buffalo, you know that the buffalo is greater. The hunter can tire, and another one can take his place. But the King can never tire -- the only abdication is death. The hunters relieve one another, for there are many of them, but the buffalo is alone. The hunter sometimes aims poorly, and kills his comrade. The buffalo has only one task, to kill the hunter. He can remove his Mlughu.

The buffalo is the greater one. It has power (nguvu). If the King sees something dangerous he can act without telling anyone. He does not tell his Mlughu but goes out at night with a club. They go on a trip. His wife walks ahead of him. When they are on the path, the King kills his wife. When he returns, the Mlughu says, 'Where are you coming from?' 'I have killed my wife.' 'Who gave you permission?' 'I have done wrong.' 'Pay the woman's father five cows, and pay the people of the country five cows.'

The buffalo is the greater one. It is he who kills people. The Mlughu is Kimweri's hunter. All the secrets of Kimweri will be known to the Mlughu. The Mlughu is his enemy. He is capable of conspiring against his master, for he knows all his secrets. The Simba Mwene's job is to kill all those who have done wrong. The people of Vugha call out 'The buffalo and its hunter!' For he stands guard by [the King]. They are placed in opposition to one another, near to killing each other. Each one knows how to kill the other. They are enemies.

The Shambaa knew that by accepting the new King they were putting themselves in danger, in the archaic sense of the English word: 'Power of a lord, jurisdiction, dominion; power to dispose of, or to harm' (S.O.E.D.). The ordinary people, by consenting to the King's accession, had given one man the power to kill, like a buffalo, tempered only by the countervailing power of the Mlughu and the King's Representatives. The King,

by receiving the right to kill, was separated from the others, alone, while his officials, the hunters, took turns watching the great beast.

The King was likened not only to a lion and a buffalo, but also to a small dog. The people of Vugha called out Kakui, mighendo mpahoe, 'the small dog walks slowly.' Dogs are used mainly for hunting in Shambaai. It is thought that plant foods are the proper diet of dogs, since they are domestic animals. The common diet of dogs in Shambaa households is left over ughai -- stiff maize porridge. But it is clear that dogs like meat. Whenever an animal is slaughtered they wait to eat the scraps and bones left behind. When dogs hunt, they are rewarded with some of the meat broth. Because a dog is both a domestic animal and omnivorous, dog meat is one of the most dangerous foods, as shown in the proverb, waughuwa ukoma, kangi waoka kui, 'you are being treated for leprosy, and yet you roast a dog' (Johanssen and Döring 1914-1915: 150). If the medical concepts were translated, one might say, 'You are being treated for diabetes, and yet you eat sweets.' This is a weak translation, however, because it does not convey the idea of pollution.

There was a form of Kilindi sacrifice in which the meat of a dog was roasted and eaten. This would have been thought to cause sickness, and possibly death, in any other lineage. For the Kilindi, however, the polluted and disgusting meat of the dog was associated with mystical power. Several men explained that the phrase, 'the small dog walks slowly,' means that the King is a powerful beast which must move slowly and carefully so as not to harm people.

The exploration of the animal symbolism has been completed, and it is now possible to discuss the dramatization of forces in more general terms. It seems to me that there were two major themes expressed, two

kinds of statement which were made. First, the actions and phrases were saying that the successor, by taking on the kingship, had become extremely powerful. The characteristics of the King's power were described. The people said, 'Down in the plains there are no birds, the small bird is silent,' meaning that no voice was heard but the voice of the King. 'Eee, he is God, eee.' They said, 'The small dog walks slowly,' meaning that the King was powerful, and that it was the power of pollution. The confrontation between the King as buffalo and the Mlughu as hunter clearly expressed the notion that the King was a killer, and that he was a lone man, separated from his many subjects and councillors. It will be shown (chapter vii) that according to Shambaa ideas of jurisprudence, only one man in the entire political unit (in this case the Kingdom) had the authority to sentence men to death. The buffalo's aloneness and its deadliness were related.

The second major theme in the nkani was that the King held his power subject to certain conditions, and there were tensions within the political structure -- built in checks -- to ensure that the King could not violate those conditions with impunity. The buffalo-hunter image indicates that while the King could remove his councillors at will, they were armed with his secrets, with his aloneness, with his need for information. The common people made it clear that if the King did not give rain they would conspire against him. This was not a reversal of status, but a conditional statement. The kingship could not be taken back. No man of Vugha could openly support the King's enemies (as he could openly support the enemies of a potential successor before the accession). But Kings of Vugha were never overthrown by Shambaa armies in open warfare; they were overthrown by secret conspiracies hatched at night by men who loudly professed their loyalty in the daytime.

The dramatization of forces took place after the successor had become King. In it, the commoners were publicly informed of the identity of their new King. They acted out, for his edification and for their own, the attributes of the office he had just gained, and the conditional quality of his authority. For the rest of his reign he would inform the commoners of their responsibilities as subjects. This was the only time they could tell their ruler of his responsibilities as King, and of the conditions for their continued loyalty.

## V

The rite of accession taken as a whole, from the time of the King's departure from Bumbuli to the completion of the dramatization of forces, has a curiously repetitious quality. The successor left Bumbuli, received the blessing of his 'mother's brother' and travelled through the night in the footsteps of Mbegha. On the following night, he was made King at Kihitu, near Vugha. He received the royal headdress, and was greeted as the Simba Mwene. At this point, however, the King continued on his way to Vugha, and reentered a transitional state, as though he had never been proclaimed King. At Fune, between Kihitu and Vugha, the councillors accompanying the successor laid him on the ground and covered him. Then a different set of councillors, led by the Mdoembazi, 'stole' the King, carried him across a stream, and took him to Vugha. The dramatization of forces repeated the incorporational action at Kihitu. The symbols were different, but the purpose was the same. At Kihitu the King was greeted as a lion; at Vugha he was likened to a buffalo. But in both places his characteristics as King were proclaimed. At Kihitu the King took possession of the headdress; at Vugha he took possession of the royal court.

The reason for the repetition becomes clear only when we examine the order of the burial and mourning of the dead King, which also seems disjointed. The King's death was hidden from the people with the greatest care, but then everyone in Shambaai was forced to mourn, and everyone was made to feel the impact of the death, with the public prohibition on farming and shaving, and with violence on the paths.

The sequence of events becomes comprehensible when it is remembered that the burial and the accession were coordinated. The new King was secretly installed at Kihitu at the same time the old King was secretly buried at Vugha. The public mourning of the dead King began only once the public accession of the new King was being completed. This is easy enough to understand. The Shambaa did not publicly acknowledge the death of a King until they had found his replacement. The new King was installed secretly the first time, so that even while the people of Vugha gathered to install him the land would not be without a King. It was the Shambaa way of saying that kingship is a continuous office impervious to death. It was, in fact, more than just a way of saying this: it was a way of shaping public experience.

The rite was not meant as a denial of the fact of the King's death, for the mourning did take place in the end. The order of the rites imposed a repetitive rhythm on the passage of time. This can be seen in each successor's return to the heroic age (in his imitation of Mbegha), and in the lunar imagery associated with the successor's journey. Here is how one informant explained the relationship between the successor, when he came from Bumbuli, and the moon: 'The moon comes from Bumbuli [in the east]. When the moon has died, and is gone it reappears. [It has not really died,] it has simply been covered over.'

There is an explicit parallel here between the moon's movement from

east to west, and the movement of the new King. It is especially interesting to note that the movements of Mbegha, as described in the myth, included travels from the south, before Mbegha entered Shambaai, and then northeastwards from Ziai to Bumbuli. The accession of the new King did not begin at Ziai, the point where Mbegha had entered Shambaai, but at Bumbuli, due east of Vugha. In most cases the successor had already become chief of Bumbuli, but even when he had not, the rites started at that town, restricting the imitation of Mbegha to movements from east to west.

I have shown elsewhere (Feierman 1970: 71-95) that the movements of Mbegha, as described in the myth, were based on the actual movements of a historic individual. In the rite of accession there was an abstraction even more extreme than that of the myth; the only movement preserved was one from east to west, like the moon; in addition, the successor travelled only at night.

The covering over of the successor's body at Fune had much the same meaning as the lunar imagery. This action seems, at first glance, to be an imitation of death and succession. The informants are quite explicit, however, that the new King was 'covered over' (-ghubikwa) with a cloth, while a dead body was 'wrapped' in a cloth, or in dead banana leaves (-gewa shanda, or -gewa mashwagho). In ordinary Shambaa usage the new moon, which cannot be seen, is said to be 'covered over' (-ghubikwa). Thus the succession was represented as a covering over and then uncovering, like the moon. After the accession, mourning continued until the disappearance of the moon under which the old King had died.

Abdallah bin Hemedi 'lAjemy, in his description of the dramatization of forces, quoted the following phrase, in Swahili: Kumekufa mwezi haraŋganyi.

yaka. lakini siyo harang'anyi ni mwezi. 'The moon has died and the evening star has appeared. Yet it is not the star but the moon' (1962: Sura 60). I have never heard this phrase used, but it rings true. The evening star is thought of as irregular and unpredictable in its movements -- 'it travels alone,' the Shambaa say, as opposed to the moon, which is perfect in its regularity.

It is the regularity of the moon's reappearance which makes it effective as an image of undying kingship. One very old man at Vugha, in trying to explain the accession to me, sought an image which he knew to be from the myths of my own people. He said: 'If Adam had not eaten the fruit in Eden, we would die like the moon.' His image of eternal life, in other words, was not of a timeless void, but of rhythmmed time, in which life is periodically covered over, only to reappear. At most times there is an identity between the person of the King and the institution of kingship, as in the proverb, Zumbe aiho ne kitaa: 'Wherever the King is, that is the capital.' To say that the King dies like the moon is to say that in spite of this identity of person and office, the kingship does not die with the King. The slitting of the drum skin, followed by the preparation of a new one, seems to have much the same meaning.

The comparison between the King and the moon was an imperfect one. The Shambaa recognize that the moon waxes and wanes at regular intervals, while death and succession were unpredictable. Before the use of the western calendar became common, people measured time in moons, and made appointments at one or two moons' remove, although to the best of my knowledge, the months were not integrated into an annual cycle. It is the regularity of the moon's movements which is perceived and emphasized by the Shambaa. There is a

proverb, Mnyanyi ni ng'wezi, hakawa kucheewa; 'the moon is a crafty one, it never lingers.' Yet it is also acknowledged that some kings reigned for very long periods, others briefly, and that the death of a king was unpredictable. In the same way, the coming of the rains is compared to the movement of the moon (see chapter viii), yet the Shambaa are painfully aware that the coming of the rains is unpredictable and irregular. Perhaps the key is that both the rains and the accession were thought to be susceptible, to some extent, to human control: the coming of the rains, and the succession of the King, should be made to resemble the regularity of the moon's movements.

There is a further point to be considered on the relationship between accession and the passage of time: the way in which the public impression of the rhythmized order of royal succession was made stronger by the secrecy surrounding the selection of the King. The public experience of the conflict over succession was being suppressed at the time it occurred. This is one of the meanings of the set phrase in the dramatization of forces: Haviongwa! Haviongwa! 'It is not mentioned! It is not mentioned!' One informant explained this phrase by saying, 'The things which are done at Vugha are not mentioned, because they are insulting. They are cunning acts of domination.'

A survey of hundreds of Shambaa oral traditions shows, however, that with the exception of the Mbegha myth, the overwhelming majority of historical traditions are reports of political competition: they are filled with the unmentionable. A remarkable feature of the traditions is the absence of descriptions of the rites of burial or accession. There is a cliché in the traditions for describing the failure of a potential successor: he is hurrying toward Vugha when he hears the drum beating in the distance, signalling the

victory of his competitor. This is the closest we get to the rites -- a drum beating in the distance.\* The exclusion of public conflict from the rites, and of descriptions of rites from the traditions, indicates that rite and tradition express complementary sets of ideas about kingship.

A description of succession taken from the traditions will establish the contrast more concretely:

When Bughe died there was a great dispute. Mboza Mamwinu [the senior Kilindi, but, as a woman, ineligible to become King] said, 'Since Bughe has died, bring Maghembe to Vugha . . . ' The woman came to an agreement with the men of Vugha. But Kinyashi [the other candidate] was at Baangai. Kinyashi's mother's brothers went to talk to the officials of Vugha: 'Take this young man as successor, not the other one.' The men of Vugha agreed, for they were given a cow by Kinyashi's mother's brothers. Messengers were sent for Maghembe . . . They were the ones who left first. Then [the men of Vugha] quickly sent someone to hurry to Baangai, to bring Kinyashi. Kinyashi left Baangai, and he spent the night at Kihitu. In the morning he was taken to Vugha, and Maghembe arrived to spend the night at Kihitu. When it was still late at night, he heard the drum sounding, and he said, 'Who is entering Vugha?' And he was told that it was Kinyashi. Then Maghembe left to go home.

This tradition describes the competition of the two men, the sources of support of each, and bribery to influence the outcome: precisely the elements which remained hidden in the accession itself. Another tradition, from the splinter kingdom of Mshihwi, shows that even the most violent competition is recalled clearly:

---

\*In this respect Abdallah bin Hemedi 'lAjjem's Swahili history of the kingdom, with its alternating descriptions of competition and rite, is completely unlike Shambaa tradition.

When Kimweri died, he left his son Shatu as an infant. Kimweri was killed by the other Kilindi [the sons of Mnkande of Mshihwi] who seized him and poured boiling water down his throat, after he had been weakened by illness on a trip . . . That is how the sons of Mnkande saw their opportunity to kill Kimweri . . . Then Nyeo inherited Shatu's mother, and when Shatu grew up he sat in his father's [royal] seat.

The grim details are coldly stated, and the ceremonies are not mentioned.

The historical traditions about succession, and the rites, had different purposes, and expressed different but complementary truths about kingship. The rites had the practical purpose of handing on the office without open conflict, separating one individual, the heir to the office, from a large group of siblings. In this context competition was hidden. But the competition itself led to the creation of new groups, or of changed relations between established groups. The historical traditions recorded the origins of the particular relations between particular groups as they developed within the broader context of generally accepted ideas about politics. Thus each of the traditions quoted describes the establishment of competing groups of Kilindi. These traditions describe events in a linear chronological order, to set the successive divisions among the Kilindi in their proper sequence.

I have made this digression on the nature of historical traditions, because it would be misleading to discuss the rhythmized time of the rites as though it had been the only (or the dominant) conception of time among the Shambaa. Different conceptions of time were appropriate to different contexts of social action. The only special claim which can be made for the rhythmized time of the rites is that for the duration of the mourning, it dominated all other time modes. Until the moon had died there was no farming in Shambaa, no rites of passage, no sacrifice. Ecological time, and the ritual time of private lineages were, for a brief period, suppressed.

There is a further point. The rites, as mechanisms for the shaping of experience, sometimes failed. In three instances of death and succession, the pressure of events forced the men of Vugha to alter the sequence of the rites. In each of these instances the burial and the accession were separated, so that there was a public experience of kinglessness and conflict before a King acceded.

The first instance occurred after the death of Kinyashi Muanga Ike in battle against the Zigula at the turn of the nineteenth century. Since Kinyashi died on the battlefield, there was no time to call a successor before burying him (Abdallah 1962: Sura 40).

The second occasion was the accession of Shekulwavu, some time between 1857 and 1862. As we have already seen, Shekulwavu's paternal grandfather, Kimweri ye Nyumbai, had been King from the early years of the nineteenth century, had grown old in office, had survived the son of the great house, and therefore instructed his court officials to install his grandson as King while he was still alive.

After Shekulwavu's death in the war against Semboja, the kingdom was without a head for several years, until the two major factions of Kilindi had completed their fight for control of the capital.

The cases in which the sequence of rites was altered should not lead us to a simple generalization that burial and accession went together in times of orderly succession, and were separated in times of conflict. The succession of Kinyashi Muanga Ike went precisely as it should have, yet it led to years of war. His death on the battlefield, and the subsequent disturbance of the rites, was followed by the longest and most peaceful reign of any King.

The burial and the accession can be taken as two separate sets of rites which were best performed simultaneously, but which could be separated. When the rites were performed properly -- when the new King was being acclaimed at Kihitu at the same time the old King was buried at Vugha -- there was no public experience of kinglessness. In these cases, the death of the old King was acknowledged only after the new King had entered the capital. But for the public experience of the King's death to be ordered, the King had to die in a convenient place at a convenient time. Because of the essential unpredictability of death, the orderlessness of experience, the elaborate ritual mechanism often failed.

## FOOTNOTES - CHAPTER FIVE

<sup>1</sup>At first I thought that the use of shanda was only a recent practice, since cloth was not easily available in the pre-colonial period, and dried banana leaves (shwagho, pl. mashwagho) are also used for wrapping dead bodies. Karasek, however, was told that Kilindi spirits could be seen at the side of a stream washing their black cloths, while commoner spirits washed white cloths (1911:193).

<sup>2</sup>This rite has not changed significantly over the past eighty years.

<sup>3</sup>As this text shows, hande is still used today. It is clear from the oral traditions that it was used in the pre-colonial period. It was mentioned, in written reports, in the early colonial period. Bethel Mission, Tagebuch Neu Bethel, 24 April 1894.

<sup>4</sup>Bethel Mission, Tagebuch Neu Bethel, 15 May 1895. "Heuschrecken und kein Ende," Nachrichten aus der ostafrikanischen Mission, May 1895, pp. 70-73.

## CHAPTER SIX

## VUGHA: THE ROYAL CAPITAL

Recording a description of the Shambaa royal capital at Vugha is made difficult by the fact that the capital has not existed as a living town for many years. Great sections burnt down in two fires at the turn of this century, and they were never rebuilt. The rest of the town gradually fell into disuse, especially after the burial there of Kinyashi, during 1933, in the royal burial enclosure (kighii, pl. vighii). Today, the sections of the town that had been occupied by the common people have become gardens. The site of the former royal court has become an impenetrable thicket, which no one enters for fear of being struck down by the protective medicines.

In order to get a reliable picture of Vugha and its place in Shambaa society, I collected a number of descriptions of the workings of the capital or of special parts of it. I collected each set of facts a number of times from a number of men, in order to be able to identify the discrepancies which resulted from the imperfect memories of old men. I relied most heavily on the testimony of three men who had held important court positions, and who had been old enough to live in the bachelors' house (bweni) of the capital before Vugha was conquered in 1895. One of these, Ng'wana Aia, a member of the lineage in which the position of chief minister (Mlughu) is hereditary, would be called on by the Kilindi to show where the original buildings had

been located if the kingdom were ever restored, and if the capital needed to be rebuilt (a possibility taken seriously by many of the former officials of Vugha, even today). Ng'wana Aia would be the authority on the royal graves in case a Kilindi is ever buried there again. Together with him, I walked over every part of the capital site, except for the court precinct, which we had to examine from its edges. I did this on several other occasions with informants who were less expert. I was able to examine copies of the two most important constructions of the royal court because King Shebughe Magogo built his great house just outside the capital in about 1930, and a burial enclosure was cleared for him next to the house when he died. I felt that there might be some reticence among the elders of Vugha about describing the magic of the capital to a private individual. I asked the former King, Kimweri Mputa Magogo, with whom I became quite friendly, to convene a conference of the elders of Vugha so that I could record a full description of the town. This conference took place in July 1968, at a time when I had finished my work with each separate informant; the individual testimonies I collected were not shaped by the group discussion.

The picture drawn from the oral testimony can be checked in a number of details against the writings of those who saw Vugha while it was still the capital of an autonomous state: Krapf (1964), Burton and Speke (1858; Burton 1872; Speke 1967), Alington (Universities' Mission to Central Africa, 1867 and 1868), Abdallah bin Hemedi 'lAjemy

(1962), and Baumann (1891). The most detailed written description is that of F. LangHeinrich, who was a missionary at Vugha from 1894-1903 (1902).

\* \* \* \* \*

Part i of the reconstruction based on all these sources examines the principles of recruitment of the town's population. It is shown that Vugha was purely a political and administrative town: its population did not gather to participate in trade, or to engage in specialized production; they came together to participate in politics.

This point is essential as background for part ii, which describes the two broad organizing plans, each of which divided the oval town in a different way, both of which were related to sets of political categories. The first of these plans was based upon the most fundamental categorization of the town's inhabitants with respect to politics. The division of the town into two ovals, one inside the other, was related to the division of the town's population into two distinct social levels: the inner oval held the household of the King, the outer oval the houses of the commoners (see map, following p.258). The other outline, in which the town was divided into an eastern and a western half, was related to an administrative division between the eastern half of the kingdom and the western half, with a concomitant division of the officials of the two halves at the capital. These two quite practical divisions -- between King and commoners, and between men of the east and those of the west -- are

embedded in more general categories of Shambaa thought, and their concrete form in the capital expresses important ideas of politics, which are examined in detail.

Part iii is a more detailed study of the royal court (the inner oval), and of its major constructions: the burial enclosure, the great house, the war house, the clearing in which cases were heard. Some of these constructions had magical properties, because of the materials of which they were built, and as a result of the special relationship between the material culture of Vugha, and the royal ancestors as the creators and preservers of that culture. As part of the relationship between the court and the ancestors, the officials of Vugha tried to respect the rule that the details of Vugha's construction could not be changed from one generation to the next. Part iv is an analysis of the effects of political change on this artificially frozen capital.

## I

This section is an examination of the principles of recruitment of Vugha's population, which was estimated in the mid-nineteenth century at 3000.<sup>1</sup> There were two main sources of the population of the capital. First, there were the ordinary subjects of the chiefdom of Vugha, that is, the larger district of which the capital was the center. These men had homes in the outlying villages, and spent only part of their time at the capital -- that part in which they

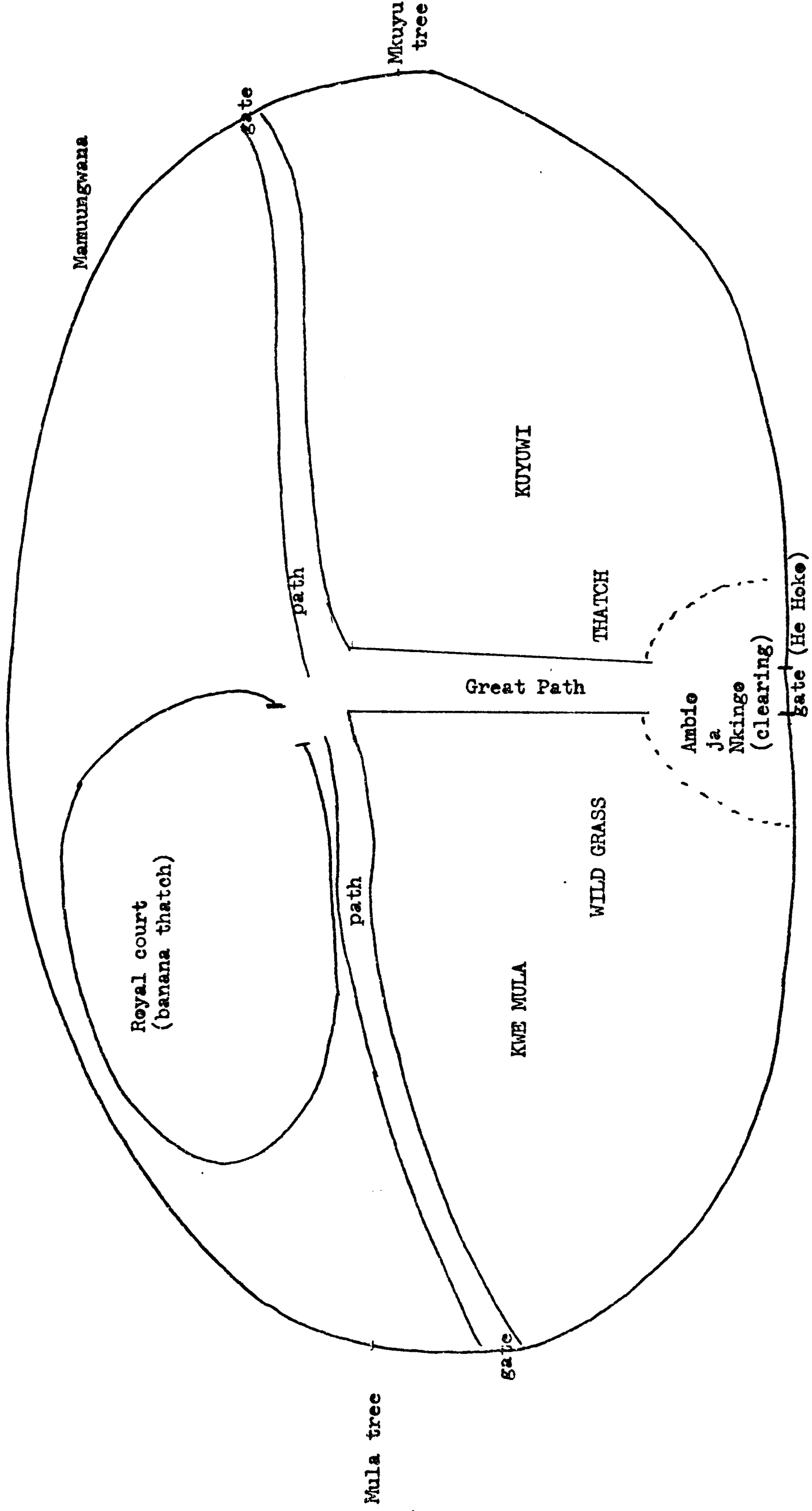

Sketch Map of Vugha

concentrated their attention on the political aspect of their lives. In addition, there were those who, whether by choice or as a result of compulsion, had become political specialists, and spent the greatest part of their time at the capital.

Vugha's sole reason for existence was as a locus for centralized political and administrative activity (and the ritual behavior associated with it). Before centralized politics had been instituted, before the creation of the kingdom, there had been no village at the spot. During one interregnum, from about 1868 until about 1870, Vugha virtually ceased to exist. It burnt down when war broke out, and was not rebuilt until a new King was installed: there was no centralized polity during this period, and therefore there was no capital.

There were only two economic activities which took place at Vugha: the production (and consumption) of bananas in the publicly owned gardens which surrounded the capital and provided much of its food (see p. 33), and the redistribution of tribute and fines. Not only were specialized production and exchange absent from the capital, but even normal subsistence activities were pursued in the country villages and farms of its inhabitants. When trade became important in the life of the kingdom, in the late nineteenth century, the officials of Vugha took the court's goods to the Zigula town of Makuyuni, about ten miles to the south, in the plains.

According to a Shambaa maxim, 'There is only one Kilindi at Vugha,' the King himself. All the other residents of the town were commoners. Indeed, within about a four mile radius of the town of Vugha, there were no Kilindi sub-chiefs, but only commoners who were appointed village headmen. The exclusion of all Kilindi but the King from the heart of the kingdom probably reduced the danger of dynastic disputes, but it also served to create a living image at Vugha of kingship as it should be: with one source of authority, one holder of power, surrounded by a sea of men from subject lineages.

Every commoner had a home village, with gardens, at some distance from town.\* In addition, each localized lineage chiefdom of Vugha was required to build and maintain a house at the capital. Because of the absence of Kilindi sub-chiefs near Vugha, none of the population was drawn off to live in sub-chiefdom capitals. A polygamous man was expected to leave one wife to care for his town house at night, while his other wife or wives stayed in his village. There was a fine of one goat for leaving a Vugha house unoccupied at night. The houses in town were very much smaller than ordinary village dwellings, because they were not the principal dwelling places of their owners. They were tightly packed in an oval area which I very roughly estimated to be one half mile from east to west and one quarter mile from north to south.

---

\*For a description of the Shambaa residential pattern see Chapter I.

The King, like the commoners, had private villages outside the town, in which he spent part of his time. Some royal villages, like Kishewa, were just a couple of hundred feet from the edge of the town. Others, like Mziyasaa, near the modern town of Soni, were several miles away. But while each subject kept only one wife at Vugha, the King kept many there.

One reason it was impossible to live solely at the capital was that women were not permitted to give birth there, or to care for infant children. A woman in the late stages of pregnancy was sent to a village. The reason for this, according to most informants, was that you could never tell when the King would be struck by the beauty of a new mother and take her from her newborn child. But in fact the King's wives also had to leave Vugha for childbirth. The most expert officials say that Vugha was a town in constant readiness for warfare. If the town was attacked, it was important for the men to go immediately to battle, without worrying about women in childbirth, or about infants. Another possibility, one never mentioned by any of my informants, is that a kigego, an anomalous birth (see p. 72 ) was an event which was thought to cause extreme bad fortune. Perhaps childbirth was excluded from Vugha because of the possibility of disastrous consequences. Even minor disfigurations were excluded from the royal court. It is said that the King could not marry a woman with a disfigured ear, and that if he did, his forces would be beaten in battle.

A number of men, called the wafuasa, 'the followers,' or the watoza mfuko, 'the bag carriers,' lived at Vugha because they enjoyed court life. The sense of danger, the constant scandal at Vugha, the sense that affairs of importance were being decided, the distribution of meat from tribute to the hangers-on, were enormously exciting to some people. There is today a great deal of nostalgia expressed for even the pale colonial period imitation of the royal capital. The King's most devoted servants were subjects who loved the life of Vugha.

One category of men who lived more or less constantly at Vugha were the husbands of the King's daughters. These royal sons-in-law were given weapons and war magic, and they became 'the fierce ones of war' (wakai wa nkondo).

In addition to the ordinary men of Shambaai who found that it was either their duty or their desire to live at the capital, there was a large group of people who were forced to live at Vugha as watung'wa, slaves or pawns. (For a discussion of this status, see Chapter VII .) Among these were law breakers whose crimes were so extreme that they were not allowed to pay the appropriate indemnity and retain their freedom. There were others whose lineage could not afford the indemnity, who were taken as pawns. Still others were people who had been driven out of their own villages after accusations that they were witches (washai), and who had sought refuge at the court of the King. War captives were also settled at the capital.

There was a final group of those who had escaped from impending punishment at the court of a chief, and sought refuge at the court of the King. It was expected that the chief would attempt to secure the return of the offender; only the King, who was more powerful than any chief, was able to give refuge without provoking a dispute. There is a proverb which explains the unique position of Vugha: Cheingia Vugha hachimuawa, 'Whatever enters Vugha, does not leave again.' Vugha was the last resort of a desperate person.

Once at Vugha, law breakers and witches were a welcome part of the establishment. It is said that they were 'the weapons of the King, who guarded his fortress.' At a time when magic was an important part of warfare, what better fighters could he find than the witches of Shambaai?. It was believed that once at the capital, near the fount of all authority, the criminal would reform, for if he violated the norms of acceptable behaviour at the court he would be killed, or perhaps sold (see p. 26). The crucial gain for Vugha was in the increase of inhabitants, for the size of the town was an indicator, and a reflection, of the King's prestige and power.

Vugha was, then, the largest single concentration of anti-social individuals in all of Shambaai. I have often heard the capital called the dung-hill (kishumu) of the kingdom. When someone from the town visited another part of the kingdom, he was greeted with a set phrase: 'How are things in the place of false witness, sir?' (Ho nkumba mghosh'?)

The slaves and pawns had residences and gardens outside the capital, in the King's private villages. Thus there was no one who lived solely at the capital, or who had a particularistic allegiance to the town, as opposed to the country. Shambaai had an administrative town which was large and complex, for its time and place, but it had no townsmen. The men of Vugha derived their citizenship in the town from their status as citizens of the wider chiefdom. The closest Shambaa equivalent for 'citizen' is washi. Shi means the land, or the chiefdom. Washi are the people of the land, or the subjects of a chief. While a citizen in English is a person of the town, the Shambaa saw living in town as a duty of one of the persons of the country.'

## II

There are important implications of the preceding argument for an understanding of the capital's form. Since there was no specialization of production or exchange, and since the men of Vugha were not true townsmen, but rather people of the country drawn together for governmental activities, the form of the capital could only be understood through its relationship to government. To put this point the other way around: the form of the capital made ideas about politics accessible to analysis by making them concrete. The articulation of Vugha's parts was related to the articulation of governmental ideas and governmental functions.

Seen as a whole, Vugha had two alternative physical outlines. The town had a diagrammatic quality: it set out, in visual form (with associated verbal communication), two of the fundamental distinctions around which the organization of the kingdom was built: a distinction between ruler and ruled, and a separation between the chiefdoms of the east and those of the west. Because the outlines were made up of concrete constructions (houses and enclosures in particular styles) rather than abstract notations, they had a capacity for the expression of the content of political ideas, and they could physically organize groups of people. Thus the study of the division between ruler and ruled will conclude with a description of the mystically dangerous quality of the ruler's court, and the study of the division between the eastern and western chiefdoms will conclude with a description of the division of the King's administrative staff between his representatives to the east and those to the west.

The whole of Vugha, as seen from the distance, comprised two ovals, one within the other, with the smaller inner oval in the north-west sector of the larger one. The two ovals were differentiated by the colour and texture of their thatch. The roofing material of the inner oval, at the top of the hill, was dried banana sheath thatch (lamba). Houses in the remainder of the large oval were thatched with wild grass (ngaghe, Cyperus exaltatus), which was shaggier in texture and darker in colour than the banana thatch.

I propose to explore the meaning of the two zones directly, by looking at the uses of the inner and outer ovals at Vugha, and indirectly, by examining the place of bananas and ngaghe grass in the context of ordinary Shambaa village life. The two methods of exploration will simply shed different kinds of light on a single image.

The grass thatch houses in the outer oval were occupied by the common people of Vugha. The inner oval was the kitaa, (sometimes kitala, pl. vitaa or vitala). The word kitaa has two related meanings. It is the rounded top of a hill, as opposed to a sharp peak. And it is also the court of any Kilindi chief; a court is usually built on the top of such a hill. The chief's court was always higher than the houses of his subjects. When, in the colonial period, a group of twelve rest houses was built at Vugha for chiefs attending conferences, the houses lower on the hillside were built on concrete platforms, so that no chief stayed in a house which was lower than that of any other. The twelve houses were downhill from the King's house.

All ordinary Shambaa villages are built at the tops of hills or ridges, with the banana gardens immediately next to the village, spreading down the slopes. The reason usually given for this arrangement is that household waste and the excrement of livestock are thrown downhill, where they fertilize the banana gardens. Ngaghe, the wild grass used to thatch commoners' houses at the capital, grows in moist valleys, below the boundaries of any gardens. The thatch of

the capital reproduced the configuration of the living plants, with the bananas at the top of the hill, and the ngaghe grass below. The contrast between the two kinds of thatch underlined the altitudinal difference between King and commoner.

The banana garden (mghunda) which grows next to a village, near a hill-top, is called the 'masculine garden,' for it is the piece of land retained by the man as a household head, after he has allocated all his other gardens to his wives. It is the garden most intimately associated with him, the one in which he expects ultimately to be buried, and the one which could never be sold by his sons after his death. Of all the property of a Shambaa man, his banana garden is the one bit over which his rights are never divided or allocated, and it is the most permanent bit.

By contrast, the moist valley bottom in which ngaghe grass grows is left for livestock to graze in. Cows from anywhere in the neighbouring area can graze in the valley below a village, since there are no individual or village property rights in grazing land (ndisha, from the verb -isha, to herd livestock).

The contrast between banana thatch and wild grass at the capital was a contrast between the houses of the owner of Vugha, that is the King, and those of the commoners, who were without property rights at the capital, and who were therefore outsiders. Further support for this interpretation comes from the rule that only the King can be buried at Vugha; burial in the banana garden attached to a homestead

is the right of the owners of the homestead. Any subject who died at Vugha was buried in the banana garden of the village he maintained outside the capital. The King's wives were buried in the banana gardens of the King's private villages, outside the town.

This interpretation needs to take account, however, of one of the King's titles, as ng'wenye shi, 'the owner of the land.' He was not called ng'wenye mzi, 'the owner of the town,' or ng'wenye Vugha, 'the owner of Vugha,' but rather the owner of the entire land. Yet it is clear that individuals, and commoner lineages, had rights of ownership over pieces of land. The imagery of Vugha, taken together with the title ng'wenye shi, would seem to mean that the King had sole possession of the political rights in the land, for Vugha was his, and Vugha represented the entire land in its political aspect.

There is a further element to consider in the relationship between the two ovals, that is, between the zone of grass thatch and the zone of banana thatch; Vugha, unlike every town in Shambaai except the town of the royal heir (Bumbui), had no palisade, and no defensive works, around its outer perimeter. There was, however, a fence around the oval of the court. And within the court, there was an oval fence around the royal burial site.

If one asks why ordinary Shambaa villages had palisades, one is told that they were simply for defence. But then the pattern of palisades at Vugha is very puzzling indeed. The Kilindi and the elders of Vugha say that the capital had no palisade because 'the

people of Vugha are the fortress of Kimweri.' There are folk tales about enemies who came to attack the town, saw that it was so large it was impossible to surround, and went home. But this does not explain why the court was fenced. If the thousands of people of the capital were overpowered, the palisade which enclosed the court would not save it from disaster.

In order to understand why fences (nyigho, s. uigho) separated the inner oval at Vugha from the outer one, it is necessary to look at a second use of fences in ordinary Shambaa villages: they were lines of demarcation, which separated the homestead (kaya) from the wilderness (tunduwi): the homestead garden (luwai), just outside the fence, was an intermediate area.

There are numerous examples of the care with which Shambaa villagers kept dangerous things outside the fence, in order to preserve the village as a safe refuge. When a diviner attributed a misfortune to the presence of a kigego (an ill-born individual, see p. 72), the kigego was driven out of his village through a hole in the fence. Witches were thought to be people who went outside the fenced area at night, naked. Any medicine powerful enough to harm people was kept outside the fence of a Shambaa village.

There were a few lineages in Shambaa which remained powerful enough to escape Kilindi rule, and govern themselves independently. Each of these villages had a ghaso, a small piece of wild forest outside the fence, in which the village's war charms were

kept, for they were too powerful, and potentially too harmful, to be kept inside.

At Vugha, however, the war charms of the entire kingdom were kept in the center of the town, within the court. The fence at Vugha separated the people who lived in the grass thatch zone from from the dangerous medicines in the town's inner oval. The inner fence, at the grave site, separated the people of the court from the bodies of the most powerful, potentially the most dangerous, ancestors in Shambaai.

An ordinary Shambaa did not go into the royal court unless he had business there, and was taken by one of the King's officials. There were parts of the royal court (around the great house) where no one could walk without first rubbing his feet with the contents of a sheep's stomach (fumba) -- a substance which was thought to neutralize the effects of dangerous charms. No one, including the King, entered the grave site except to sacrifice. Today, with the town gone and the site unoccupied, people farm in what had been the zone of grass thatch, but no one enters the zone of banana thatch at the top of the hill. The people of Vugha say that if you enter the court you will die. A thicket has grown up at the court, and in it the monkeys which eat the crops have found a refuge, for no person of Vugha dares to pursue them there.

The reversal of the normal order of things, with the placing of the most dangerous medicines at the center, and above the rest of the

town, was related to the reversal of the placing of doorways of the houses in the outer oval of Vugha. In ordinary villages, the doorways of all houses face downhill, so that when people dispose of refuse it falls into the gardens. But at Vugha, all doorways faced uphill. There is a proverb which refers to this, which uses the verb -asha, to dispose of, or throw away. The Shambaa speak of throwing away garbage, but they also speak of 'throwing away' in the wilderness the corpse of a man who died of a dangerous disease, which might continue to harm the living. The proverb is, Viwiwi vyoshe vyaashighwa na kitaa, which means, 'All dangerous, inauspicious, evil things are thrown away to the court.'

The gate in the fence around the court warns of the dangers of the powerful charms inside, for the two posts of the gate are mvumo trees, of which the maxim states: mvumo koma ng'wenyezi -- 'the mvumo kills the autochthon.' The mvumo is a liana, a climbing vine which twines itself around a tree, sinks roots into the ground, and then grows as large as the host tree, which slowly dies.<sup>2</sup>

The mvumo is a symbol of the power to kill. When a person thinks that he has been ensorcelled, or may be ensorcelled, one form of defense is blood partnership with an mvumo. This is often done by a person on his way to becoming a medicine man himself. The person who is going to make partnership goes to an mvumo with the medicine man who is treating him, and takes off his clothes. The medicine man then makes a number of cuts on the patient's body, and a number of cuts on the mvumo. He places sap from the mvumo on the body cuts, and

blood from the patient on the mvumo's cuts. The medicine man then says, "Oh mvumo. You kill your companions. We are making blood partnership between you and this person. Kill the medicines as you kill your fellows."

The King is often explicitly compared to an mvumo, for he is an outsider who has power over the indigenous people. This was explained to me by an informant who was talking about Mbegha, the first King. The informant, a man of the Hea clan, explained that Mbegha came peacefully, and was welcomed by the Shambaa. A bit later, the same man described how Mbegha had plotted to have the Hea leader killed. How, I asked, could Mbegha be called a peaceful man when he plotted murder? 'Mbegha did not come in a war-like way,' said the informant. 'He was like an mvumo. When it roots itself in the earth, the host tree dies.'

The fence around the court, the mivumo as a gate, the thresholds of the grass thatch houses facing uphill, the belief that dangerous things belong at the court, all show that while the capital was the King's homestead, the homestead was no ordinary one: it was an inversion of a proper homestead. In an ordinary village dangerous substances were kept outside the fence; at Vugha they were kept inside, at the center. The King's possession of territories far greater than the ordinary man's gardens was associated with a

concentration, at the center of the kingdom, of the terrible power normally associated with the wilderness.\*

The configuration which has been examined up to this point, of the capital as a double oval, was merely one of two alternative configurations. The second was based on the cardinal points. The two images were not opposed to one another, or mutually exclusive. They were spoken of in slightly different contexts, and they could be superimposed, one on the other.

If one stood at the entrance to the royal court, near the center of the town, a large mula tree (Parinari excelsa) was visible at the western point of the compass, and a giant mkuyu<sup>3</sup> at the eastern point. The town was divided into the sections of Kwe Mula, the western half of the town, literally in the direction of the mula, and Kuyuwi, the eastern half, in the direction of the giant mkuyu. The species of the trees is said to have had no particular significance; it was their location at two of the cardinal points which gave them their importance.

East, in Shambaa, is referred to simply as 'the direction from which the sun rises;' and west 'the direction of the setting sun,' while there are no special names for north or south. A north-south line is described as 'cutting the sun'. But even the direction of

---

\*This concept has been mentioned in Chapter IV . Its implications will be discussed in Chapter VIII .

the rising or setting sun is rarely referred to in everyday conversation. All directions are given by place name: "The village you are looking for," someone might say, "is further along, in the direction of Mombo." This means, of course, that each neighbourhood in Shambaai has a different set of names associated with given directions, for Mombo is south if you live in Lushoto, but west if you live in Bumbuli. The reference is made clearer by the fact that there are dozens of mountain peaks in Shambaai, each with a distinctive shape. One always knows one's location by the shape of the surrounding peaks. This digression explains, then, that it is normal and proper Shambaa usage to divide the town with reference to the cardinal points, but then name the sections after local landmarks.

Within Vugha, the line which divided Kwe Mula from Kuyuwi was 'the great path' (sia nkuu), which formed a north-south line in the grass thatch zone leading from the gate of the royal court to the 'skin drying ground' (ambio ja nkingo), an open space at the southern edge of the capital, which was used, as the name implies, for pegging animal skins to the ground, but also for large public meetings.

There was an interplay, in the design of Vugha, between landmarks which were easily visible, and those which were important in the structure of the town. Thus the north-south path was called the great path, even though there was a larger and more commonly used thoroughfare, the one to which LangHeinrich referred as the main street, which wandered its rough course from east to west through the

town, a meter and a half wide, and fenced on both sides. The main gates through which visitors entered Vugha were thus on the eastern and western sides, although the entrance which was important in the rituals of the capital was He Hoko, at the southern point of the compass, just beyond the skin drying ground. When the men of Vugha went to war, a sheep or chicken was hurriedly sacrificed there, the warriors were smeared with medicines, and then they left the capital by jumping over the prostrate body of the Ngovi, one of the minor court officials.

Each subject of Vugha participated in the working groups of that half of the town in which he lived. There were the King's farms of the east, cultivated by the residents of the eastern section, and the King's farms of the west, cultivated by the westerners. There were separate bachelor homes of the two halves.

The royal court was completely in the western half of the capital. The gate to the court, formed by the two mivumo, was at the southeastern edge of the court, facing south, and so it was at precisely the point the people of Vugha thought of as the center of the capital.

The two halves of Vugha corresponded with two halves of Shambaai. Indeed, the officials of Vugha, when they spoke of the chiefdoms, retained the terms of reference drawn from the local landmarks: every chiefdom was classed as either a chiefdom of Kwe Mula (the west) or one of Kuyuwi (the east). The border between the two parts

of Shambaai was a pair of rivers. The two had their sources near to one another, in the vicinity of Bagha (northeast of Vugha), at the watershed of central Shambaai. The elders of Vugha speak of them as 'waters which divide.' One river flowed southwest, through a valley which passed near Vugha, and descended to the plains. The other flowed north from Bagha, past Makanya to the Umba plains. The great path through the center of Vugha corresponded to the rivers which divided the mountain block.

Each half of Shambaai, as divided by the rivers, was administered by officials in one half of Vugha, as divided by the great path. The governors of the chiefdoms were all members of the royal dynasty, but the officials who mediated between the King and the chiefdoms were men of common lineages who lived in the zone of grass thatch. The six most important officials were called wafung'wa (s. mfung'wa) or alternatively walau (s. mlau). Mfung'wa had probably been the title of local political leaders among the Shambaa in the pre-Kilindi period. Mlau meant a messenger. I shall call the wafung'wa-walau the King's representatives.

Only the King and the chief minister (Mlughu), who lived with the King in the court, could deal with the affairs of all parts of the kingdom. There were three representatives of the King to the eastern part of Shambaai, who lived in the eastern section of Vugha, and three representatives to the west. The three in each half were ranked, and each representative had a counterpart of equivalent rank

in the other half. The representatives, in ranked order, were the following:

KUYUWI (east)	KWE MULA (west)
1. Mdoembazi	1. Kaoneka
2. Mdoe	2. Doekuu
3. Beeko	3. Mbaruku

There was an informal chain of command within each section. The chief minister might, to quote a hypothetical example, ask the Mdoembazi to deal with a border dispute between two chiefdoms in the east. The Mdoembazi might, in turn, ask the Beeko to deal with the situation.

In addition to generalized responsibility for affairs in one half of the kingdom, each of the King's representatives was the official mediator between the court and several of the chiefdoms. In most cases it was the representative for Bumbuli, for example, who was sent to oversee affairs in that chiefdom. And if someone came to Vugha with a matter for the court's consideration, he went first to the representative attached to his own chiefdom.

The way in which representatives were assigned by the King is illustrated by the report of Johann Krapf, the missionary, who was given permission by Kimweri ye Nyumbai to build a mission station at Tongwe, in the eastern part of the kingdom.

In Krapf's own words:

17 March [1852]. Mbereko [Beeko] . . . informed me that the King had ordered that all my affairs should henceforth be in the Mbereko's hands, and that I should have no doubt of being given Tongwe, or Mringa or Pambire as a mission station. I thanked him for the King's kindness, and asked that the King tell me these things in person.

18 March. . . . The King said: 'I grant the European's request for Tongwe, and I appoint you, Mbereko, to carry out my wishes in this matter.' Mbereko took the King's right hand and pressed it against the King's body, which probably is a kind of sworn assurance. Through this act the Mbereko became my mlau, i.e. guide and mediator. Every chief, even if he is the son of the King, must have an mlau at the court at Vugha, to be informed of all his affairs, and to bring him before the King. Mbereko is also the mlau of the Pangani and Tongwe districts (Krapf 1964: part 2, 307-308).

Krapf's report is crucial evidence for the historical validity of the oral accounts which I collected. The description of the halves of Vugha, and of the association between those halves and the two sets of King's representatives, is based on the oral reports. Krapf had no systematic understanding of the organization of the capital; he simply reported the random details with which his activities brought him into contact, during his visits of 1848 and 1852. And yet the details reported by Krapf correspond completely with the systematic accounts by Shambaa informants. The Beeko, according to the informants, was a King's representative to the east, to whom responsibility was given as official mediator for particular chiefdoms in the east; Krapf reported that the Beeko was official mediator to Pangani and Tongwe, in the east, in 1852. According to

the systematic oral descriptions, the Mdoe was another representative to the east; Krapf saw the Mdoe collecting tribute at the extreme eastern edge of the kingdom in 1852 (1964: part 2, 276).

The Beeko, and his colleague in the west, the Mbaruku, were also the leaders of the two armies of Vugha.\* Each man kept a magical war staff and a war banner in his house, and after about 1840 each kept a quantity of gunpowder and some guns. Each army provided the first line of defence against attacks from its own direction, and served as reserves if the attack came from the other direction.

All the court officials served at the King's pleasure. There were two positions at the court which were said to be hereditary: the Mlughu, of a lineage which was said to have accompanied the founding King to Vugha, and the Kaoneka, the leader of the King's representatives of Kwe Mula, of the lineage of the Wakina Tui, the original inhabitants of Vugha who welcomed the founding King. But in fact the King replaced officials as he pleased, and all the offices circulated among a number of lineages.

The nature of recruitment to the official positions can be seen from the career of Senkunde, who rose through the court hierarchy during the middle and late nineteenth century. Senkunde was brought up in the chiefdom of Bumbuli. He was somewhat wealthier than most

---

\*Here, too, Krapf confirms the oral reports. He saw the Beeko leave Vugha with armed men to defend against a Zigula raid in 1852 (1964: part 2, 309). Krapf does not mention whether the raid came from the east or from the west.

Shambaa, but his paternal grandfather had been an immigrant to Shambaai, and so Senkunde did not have the advantage of a historical lineage alliance with the King. As a young man, Senkunde left home and lived at Gare, where he acquired a reputation as an excellent performer of the wia, a dance which was then popular. Largely because of his dancing, but also, no doubt, because of the social skills associated with it, he was made zumbe wa bweni, chief of one of the bachelor houses at Vugha: a minor position. While serving at this post, during the reign of Kimweri ye Nyumbai, he was thought by the officials and by the King to be intelligent, and deserving of advancement. Before he rose to a higher position, however, a test was set for him. One of the King's wives was sent to seduce him, and because he resisted, he was made Mdoe of Vugha (a King's representative to the east). Senkunde served as Mdoe until after the death of Kimweri ye Nyumbai, and the succession of Kimweri's grandson, Shekulwavu, when he became Shekulwavu's Mlughu. During the succession dispute in the 1860's, Senkunde connived at his master's overthrow. Semboja, the victor, rewarded his ally by giving him his sister as wife. When Semboja made his son Kimweri Maguvu King, Senkunde became this King's Mlughu as well.

### III

Up until this point we have looked at the royal court from the distance, perceiving that it was fenced, that the houses were thatched with dried banana sheaths, that there was a burial enclosure inside,

and two mivumo trees as gateposts. A simple distinction has been made between the royal court, which was the inner oval, and the outer oval of grass thatch, which contained the houses of the common people of Vugha. The court precinct itself, however, was dense and complex, for in it the work of the King and his officials was done, and in it rites were performed for the well being of the entire kingdom. The court deserves detailed examination.

As the study of the rite of accession has shown (Chapter IV ), the potential successor who entered the court precinct and took control of it was indisputably the King. The other potential successors, who were competing with him, became mere insubordinate chiefs the moment he entered the royal court. The court was unique, it could not be duplicated, and the Kilindi who possessed it was King.

The reasons for this have to do with the nature of the major constructions at the court, and the relationship between those constructions and the royal ancestors. Each of the major constructions (the burial enclosure, the great house, the clearing for cases, the house of war magic, all described below), was thought the appropriate location for a particular set of activities of the King and his officials. Some of the constructions were made of prescribed materials in an integrated design, so that they had magical efficacy. But the constructions at Vugha were differentiated from similar ones anywhere else because they had been used by the former Kings of Vugha, the details of design had not been changed (it was said) since the first King had used them, and those Kings were buried at the court. Pretenders could, and did,

construct towns named Vugha at other places; they could build replicas of the great house, or of the house of war magic; but these were mere ersatz constructions: fake antiques.

In order to understand the importance of the royal court, the reason that no elements in the design could be altered from one generation to the next, the reason the constructions at Vugha were more potent than the imitations, the reason the possessor of Vugha was acknowledged King, it is necessary to digress on the Shambaa conception of the relationship between learned behaviour and the ancestors.

The key concept for an understanding of this relationship is the term fika. Fika is a noun related to the verb -vika, which means to perform a rite, or to invoke supernatural beings (usually ancestral ghosts) as part of a rite. The word fika is used in one sense to mean the rite performed. It is possible to specify the kind of rite. Fika ya ukaa is the rite done before hunting. Fika ya chekecheke is literally the fika of the clinking bells, performed for a man who has died in the recent past.

Fika also means an artifact or a kind of action which is reproduced in an unvarying manner because it is inherited. Fika, in this sense, is something which has come to a person through a line of descent. This meaning is not altogether different from fika as ritual. A man made this clear to me when discussing the fika of the clinking bells. He said that if a man does not perform this rite, he will inevitably lose all his possessions, and die. I replied that

I had not performed the rite, and yet I was still alive. The man was not at all taken aback. He told me that it was not a ritual my ancestors had done, and therefore it would be senseless for me to perform it. Fika, in the sense of patrimony, extends to many kinds of learned behaviour besides ritual invocations. A smith said, of his lineage, kushana ni fika yawe: 'smithing is their fika.'

Over the past fifty years mila, a Swahili word of Arabic derivation, has come to be used interchangeable with fika, in the sense of patrimony.<sup>4</sup> In fact, the smith's full statement was: Washiaghi ni mila. Kushana ni fika yawe. 'The smithing lineage is mila. Smithing is their fika.'

When talking about technology, most Shambaa speak not of new and old things, but of the patrimony of different peoples. I was told that cars were mila of the British, but not of the Germans, because there were no cars in Shambaa before the British took over Tanganyika during the First World War.

At Vugha, there were two relevant bodies of fika. First, there was the patrimony of all Shambaa, called fika ya Sheuta na Bangwe, 'the patrimony of Sheuta and Bangwe,' who were the primeval ancestors of the Shambaa people. Second, there was fika ya Mbegha, 'the patrimony of Mbegha,' the first King. This included objects and patterned behaviour specifically associated with chiefship. But in fact the two kinds of patrimony are often used in overlapping senses because of the long association of the Kilindi and the Shambaa.

People speak of irrigation channels as 'the fika of Mbegha,' even though they know channels were used before the time of Mbegha. And chiefship is called 'mila of the Shambaa.' The regalia, however, would never be called the patrimony of the Shambaa; they are the patrimony of Mbegha, or of the Kilindi lineage. This point was tested in a court case shortly after Tanzania's independence, and the abolition of chiefship. A number of the men of Vugha sued the former King for possession of the royal headdress (described below). They argued that the regalia were the property of all Shambaa. The former King replied that they were the patrimony of Mbegha, and that as the descendant of Mbegha, he was the owner of the headdress. He won the case.

Vugha had to remain true to the patrimony of the Shambaa. The houses of the town could only be built in the bee-hive style (mundi), because that was the style used by the ancestors. Even when other villages in Shambaa were adopting foreign styles, Vugha could not change, for it had to remain essentially Shambaa. Every bed at Vugha had to be made in the banti style: a frame covered by the ribs of the raphia palm.

Because foreigners unavoidably came to the Shambaa capital, a separate section was built for them just outside the eastern edge of the town. This was Mamuungwana, literally 'the place of the coastal people.' The houses of Mamuungwana were built in the rectangular style which was the coastal mila.

The patrimony of Mbegha included the most important magical constructions at the royal court, which had existed, supposedly unchanged, from the time of the first King. Because of the central place of the ancestors in Vugha's magic, the most important construction was the royal burial enclosure, the kighii, in the north-eastern sector of the court. Vugha was the only town in Shambaai which had a continuous series of graves from the early days of the kingdom. There were grave sites at the capitals of the chiefdoms, but when a new King established his rule at Vugha, and sent his sons out to govern, the graves of the old chiefs were forgotten, and a new enclosure was begun. The local historians in the chiefdoms remember back to the beginning of their current chiefly line, usually in the second quarter of the nineteenth century, and then probe back into more distant times by recalling the history of the early Kings of Vugha. Bumbuli, in the east, was the chiefdom of the royal heir, and so it was the perfect historical town, for its chiefs were expected to die at Vugha, as Kings. Only at Vugha was there a continuous line of Kilindi ancestors. We have already seen, in the chapter on royal descent and alliance, that because the kingdom was passed on undivided to the son of the great house, the influence of the dead Kings was never dissipated. Since each dead King had possessed and then passed on the entire kingdom, all of them could influence its fate. The continuous line of dead Kings, whose graves were in the enclosure, had an importance for the well being of the kingdom which no series of lineage ancestors could ever have had for their descendants.

N



Great Path

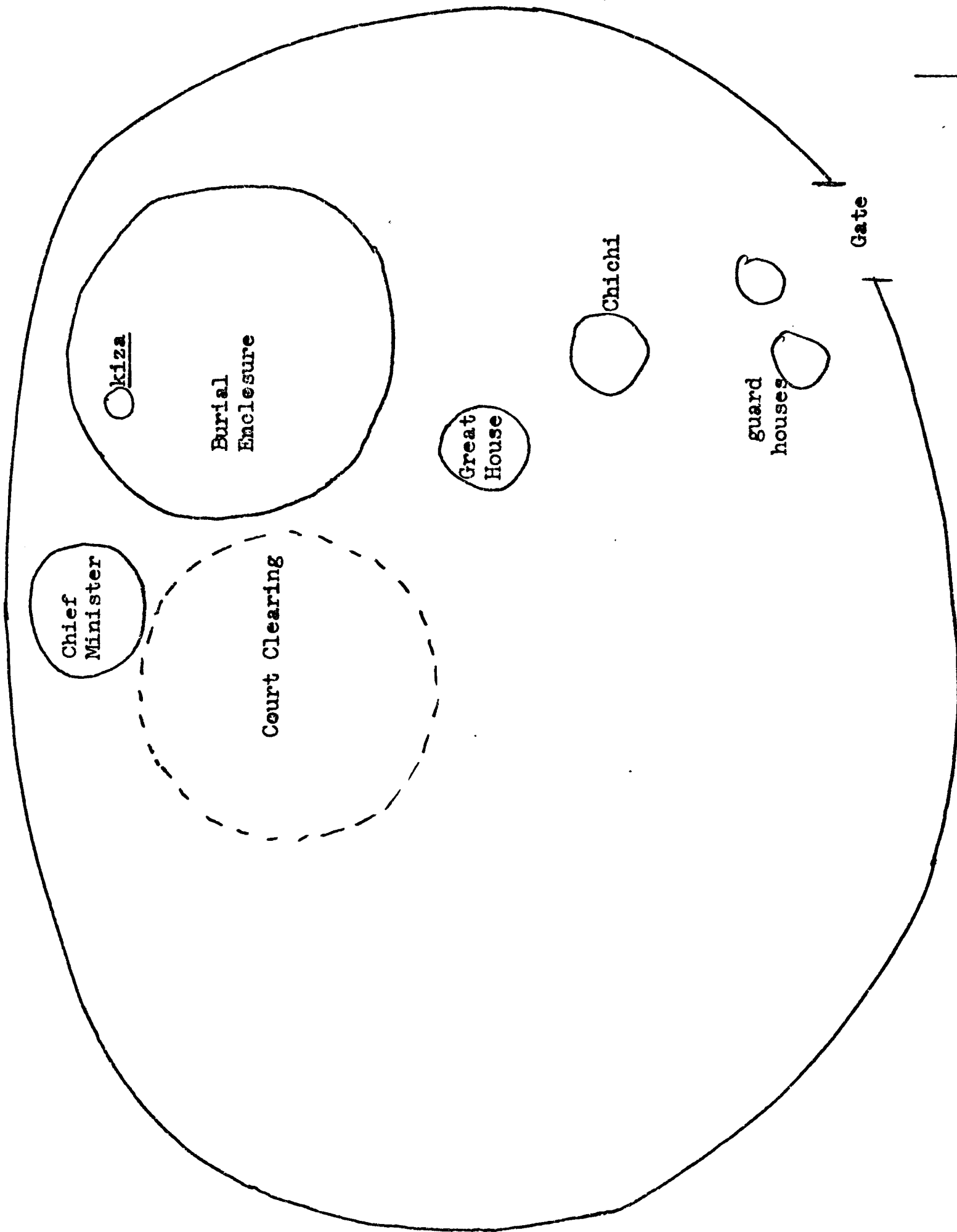

Sketch Map of the Royal Court (zone of banana thatch)

There is considerable confusion, among the men of Vugha, on the orientation of a King's body in its grave. My informants could not agree on whether the King's body faced in the same direction as the body in a commoner's burial, or in the reverse direction.

In the burial of a commoner, the grave is dug so that the long axis of the hole runs along a hillside, and the body is said to be placed so that there is a set of correspondences, with a man's body lying on its right side, facing 'in the direction of the rising sun,' and facing downhill (nyika, literally the plains), and a woman's body lying on its left side, facing in the direction of the setting sun,' and facing uphill (Shambaai or kenya). The explanation for this, which is agreed on all over Shambaai, is that women should face the hills and the setting sun so that they can return home in time to cook in the late afternoon. Men face the rising sun so that they will not delay their early morning hunting trips to the plains. Irregularities occur, in the burials, when east is not downhill. I observed the burial of a woman whose body faced east, because it was uphill.

There was no difficulty with this set of correspondences at Vugha because the council clearing, which was the highest point on the hill, was directly to the west of the burial enclosure. There is, however, considerable disagreement over the direction in which the dead King faced. A Kilindi of Mshihwi told me that a chief faced east and lay on his right side. A Kilindi of Vugha said that he lay

on his right side facing west. The former Mbaruku of Vugha said, 'It would be appropriate for him to lie on his left side.' The hereditary chief minister of Vugha thought left. In a conference to which the former King called a number of court officials to assist me, an Mdoe of Vugha ended the argument on this point by stating that Shebughe Magogo, the most recent King to have been buried by these men, was laid on his right side, facing east.

The remarkable thing about this disagreement is that it occurred at all. All Shambaa agree completely and unhesitatingly on the orientation of the bodies of commoners. One would think that the King, as the most supremely masculine of all Shambaa, and the descendant of Mbegha the hunter, should face the plains and the east. This remarkable situation reminds one of Needham's note on the Mugwe, a religious dignitary among the Meru of Kenya (1960). The left hand of the Mugwe of the Imenti sub-tribe is regarded with awe, although for Meru in general the right hand is pre-eminent. Needham argues, convincingly I think, that the exceptional status of the Mugwe's left hand marks his exceptional personal status. For the Shambaa King, however, the right hand was clearly and unquestionably pre-eminent in all other contexts. It would seem that for the Shambaa, it was the exceptional character of dead Kings, as opposed to living ones, which was marked off. For those Shambaa who see the King's burial on his left hand as appropriate, the inversion would be in harmony with many others associated with dead Kings: burial at

night instead of day, in secret rather than public, wrapped in black rather than white, and with the graves at the centre of the town rather than outside the fence.

The burial places of the individual kings were not, so far as I know, marked in any special way, although the senior officials of Vugha remember the place of each King within the enclosure.\*

The only object inside the burial enclosure, aside from the graves of the Kings, was the kiza, an earthen pot which was part of a magical assemblage for bringing rain. Here is how the leader of the lineage which supplied the hereditary Mlughu described the use of the kiza:

The rain magic is the kiza, which is in the burial enclosure, near the houses of the Mlughu (at the northwest edge of the court). It is a round bottomed earthen pot which rests on a ring of soil. Inside there are medicines. And also, there is soil and the edible plant known as eze (pl. maeze, Xanthosoma violaceum). When it rains, the maeze sprout. When there is drought, and the sun glares down, the maeze die, but beneath the soil they are still alive. Only the visible part dies. When there is excessive drought, a nkombwe (a lad who has not yet gone through the gao initiation) is sent to the river to bring water. Two men wait for him, and they take the water from him. Then they pour the water into the kiza, and they remove the dead leaves. Finally, they take the dried crumbled leaves of a certain tree, and rub them into the pot. The next day it rains. I myself went, together with the Shefaya, to do this, but I don't know what the leaves were, because I was given them by the King.

---

\*The following Kings were buried at Vugha, in the enclosure: Bughe, Maua, Kinyashi Muanga Ike, Kimweri ye Nyumbai, Shekulwavu, Kimwei Maguvu, Kinyashi.

It is not altogether clear why an uninitiated boy is sent for the water. There are several facts which are relevant for understanding this practice, but which do not make it possible to construct a complete explanation. There were two categories of males who were not allowed to enter the burial enclosure under any circumstances. One was the nkombwe, the boy who had not been through the gao initiation which normally took place during adolescence. There was a Christian Mlughu during the 1950's who had never been through gao, and who had to undergo a small initiation ceremony before he could take up his position. A kiema was also excluded from the burial enclosure. This was a man who was disfigured in some way. (See p.150 ). Neither the uninitiated man nor the disfigured man was allowed to go to war. In addition, the uninitiated boy was unable to take a wife, and if he begat a child, the child was killed. In the magic of the kiza, the weak, incomplete outsider served the strong, experienced insiders, so that they could bring rain to the kingdom.

The magic of the kiza existed before the kingdom had ever been created. According to traditions, the leader of the Hea lineage had possessed the kiza, before he had been killed by Mbegha, who took his magic. Because of the kiza's great antiquity, it was difficult for the Kings to establish a monopoly, and so the kiza survived in other forms around Shambaai. There were some places where just a single king'weng'we tree (*Dracaena deremensis*), planted in the middle of a

banana garden, was called a kiza. The banana shoots were placed near it before they were planted (LangHeinrich 1921: 169). In other places, a pot of water was placed in a banana garden, and king'weng'we trees were planted around it.<sup>5</sup> The tree in question has a tall thin trunk, with a crown of dark green rubbery leaves at the top. It is said to grow with spectacular rapidity, and to flourish through the worst droughts.

An examination of the variants of the kiza sheds light on the nature of the burial enclosure, for the fence of the enclosure consisted of king'weng'we trees, planted at regular intervals, with branches and pieces of wood woven between them. This means that the entire enclosure, including the grave sites, the pot, and the fence, was a single kiza -- a single rain shrine. This was not the sole use of the burial enclosure, but it pervaded all elements of the enclosure's design.

To the south of the burial enclosure, between the enclosure and the court's gate, was the great house (nyumba nkuu, or buia), a second major construction in the royal culture of Vugha. The great house was associated with the King's great wife, mother of the royal heir, who often stayed there. The lion skin, on which the 'son of the great house' was said to be born, was kept there, along with other relics of Mbegha's era. When the King, like any other household head, held the sacrificial rite for his father, or initiation rites for his own children, the great house was the scene of the

ritual. In this respect he behaved no differently from his most humble subject, holding a ritual in his senior wife's house.<sup>6</sup>

Like any householder, the King kept some of his most powerful protective charms in the house of his great wife, but because he was King, the charms surpassed all others in their power, and they protected an area much wider than the King's household, unless one takes his household to be all of Shambaai. Among these was the drum called Nenkondo. This was said to have a man's fist inside, which could beat warnings. A man who had seen the drum without its skin, after it had been pierced at the death of a King, and before it had been covered again, remarked that if one peered inside, in the hope of seeing the fist, it became invisible. When the drum beat, it was a sign that an attack would be made on the King's territories within the next few days. Nenkondo also is said to have signalled the impending death of a King.

The Linga, the King's headdress, was also kept in the great house, although it was taken on state trips. The Linga has a band, two lion's claws on the front, some smooth pieces of wood, and five long ostrich feathers. There are no ostriches in Shambaai, but only in the plains. Ostrich feathers have no other ritual or magical use that I know of among the Shambaa. The Linga was an important object of war magic. It protected the King's house from invasion, and he wore it in battle.

The great house was a convenient large house in which state business could be conducted. Cases could be heard there, if rain or cold made the outdoor clearing uncomfortable. It is said that one of the special properties of the great house was that no matter how many people entered, at such times, it could not be filled. There was a special etiquette for entering. One approached an ordinary house by standing at the door, and calling out to the woman of the house, who returned the greeting. But a man who came to the great house on business entered silently, sat down near the doorway, and only then uttered his greeting, which was shayo matuo -- 'I come to pay homage.' The constant arrival and departure of subjects at the great house never presented a danger. There was an iron cow bell at the side of the front doorway, and it was thought that if anyone tried to steal from the house, or to place harmful magic there the bell would ring.

The number of main poles used in the construction of the great house had to be the same as the number said to have been used by Mbegha. The beehive formation was achieved by fixing five flexible poles in the ground around the perimeter of the house, joining them at the top to the main center post, and then weaving in smaller flexible trees and lianas, onto which mud was smeared and banana thatch tied. In the construction of the door, too, the parts were grouped in sets of five. The door was woven of lianas, each about a finger's thickness. The warp of the door consisted of five sets

of lianas, each of which had five strands. The lianas of the weft were not woven in and out between each strand, but between each group of five strands.

The five flexible poles of the great house, the five sets of five lianas in the door, and the five ostrich feathers in the head-dress are said to have represented the five chiefdoms of the early kingdom. There is no agreement on which chiefdoms these were, but certainly there were more than five chiefdoms in the kingdom in every generation after that of Bughe: Mbegha's son, and the first King buried at Vugha. It would seem that Vugha took its shape during this period, and, because of the rules governing its construction, survived in later times as a living museum of early Shambaa life.

If the five flexible poles of the great house represented the five chiefs, the center post (mkoa) represented the King himself. In explaining this to me, one of the men of Vugha said: 'When a house like this one is built, if it were not for the center post would the house stand firm? If it were not for these poles, would it stand? If you can understand that a house is its center post, for us, for the people, the center post is the King.'

The house known as chichi, the war house, was located inside the court, near the gate. When the old chichi house began to fall apart, it would be torn down and a new one built on the same spot in a single day. I have never heard a reason given for the rule

requiring such great speed at building; perhaps it was thought dangerous to leave the kingdom without its magic for an entire day and night.

A single kind of wood was used in building the chichi: that of the mvuti (Lippia asperifolia, or L. ukambensis). The mvuti is used in a number of protective, defensive medicines. It is thought able, in defensive magic, to cause the swelling of the body of someone who violates the protected place. When used in protective medicines, the medicine man says, mvuti ghenda kavutishe -- 'mvuti go and swell the body of . . . ' This is partly a play on the similarity between the words mvuti (the plant) and -vutisha, to cause swelling. In addition, the wood of the mvuti is white, and there is an oath, using the mvuti, in which people swear on their mothers' milk that they will not use sorcery. In the house of chichi the mvuti was used without the swearing of a spell, because the purpose of the mvuti was clear enough from the context in which it was used. This is similar to the use of the mvuti in the sacrifice of the clinking bells, where the context of the tree in the rite takes the place of the usual spells. In the same way that the burial enclosure, as a whole, formed a rain shrine, the house of chichi, in its very construction, was a form of defensive magic.

The King's collection of war medicines -- a collection to which he was constantly adding -- was kept inside the chichi, mostly in inedible gourds and the horns of wild animals. When guns came into use, they too were stored inside chichi.

The zumbe wa chichi -- the official in charge of the war house -- was an unmarried slave (mtung'wa). He wore a brass neckband as a sign of his office, and when it was time for him to marry and give up the job, the neckband was removed and he was given a cow as a reward for his labours. His job was to invoke the spirits of the dead Kings, who had first acquired many of the most important medicines stored in the chichi.

Much of the important litigation, and many of the major meetings at the court took place in the kitaa cha masa -- literally 'the court of cases.' This was a clearing at the highest point on the hill of Vugha, just west of the burial enclosure. Aside from a clearing, of a size adequate for assemblies of the respected men of Vugha (watawa, s. mtawa), the only physical features of this court were a group of five large stones, on which the King and his four senior officials could sit, and a large mvumo tree, which cast the cool shade which was thought appropriate for the hearing of cases.\* It has already been shown that the stones were symbols of the invulnerability of the King and his major officials to attack (see Chapter IV). The King sat in the center. To his left, in the west, the direction of Kwe Mula, was the stone of the Mlughu, and the stone of the Kaoneka. The Doekuu and the Mbaruku, the King's other two representatives to the west sat on the ground. To the King's right, the east, were the stones of the Mdoembazi and the Mdoe. The Beeko sat on the ground.

---

\*For a discussion of the mvumo and litigation, see Chapter VII.

The greatest number of the houses at the court were those of the King's wives, and they had no names or special ritual significance. The wives who lived at court were the subject of much of the gossip of Vugha, and were at the heart of endless plotting and counterplotting. Just as the presence of one Kilindi and many commoners at Vugha was an expression of the sovereignty of the King, so was his position as the one man with many wives at the capital among many men, each with one wife.

There were two guard houses at the gate to the court. One was the bweni, the bachelors' house for the King's sons and the other young men of the court. These kept watch, and the older ones went along with the King to battle, although they were not considered mature enough to be in the front lines. The other house was that of the walughojo (s. mlughojo), the casual labourers, servants, guards, messengers of the court. All the adult male citizens of the chiefdom of Vugha took turns at serving as walughojo, with first one village then another conscripted. One set of walughojo served for four days, and was then replaced by another set. Four days was also the length of a market cycle (Feierman 1970: 130), and so the two cycles were probably coordinated.

Finally, there were, at the court, the residences of the King's household officials. Of these, only the Mlughu, the King's chief minister, was involved in making important political decisions, which affected subjects over an area larger than the capital (See p. 276).

The two most intimate of the King's officials were the Kihii, literally 'the secret' (alternatively called the Shefaya), and the Mshakamai, literally, 'the guardian of the wealth.' These two officials concerned themselves mwe mbui za shoni 'in matters of the King's shame.' The Mshakamai supervised the King's wives. If one of them needed to go through the rite of passage which took place after the birth of a woman's first child, the Mshakamai went with her to the village of her father, and took the place of her husband in the rite. The Kihii cared for the King's headdress and carried it when the King travelled. The two officials looked after the medicines if the King was ill. They never divulged the secrets of the court. It is said that they swore blood partnership with the King, and were sworn, in it, to silence. My most frustrating interview was with the former Kihii, who respected his vows of silence.

There were a number of other, more minor officials, some of them serving for the court's amusement. The mdimu was the court jester. He had a headdress with one ostrich feather, instead of five, and he would strut about in it, mocking the King and the officials at the court. The Nyeghee tasted the King's drinks, to show that they were not poisoned. The Kiuzio was the town crier, announcing the King's orders daily, and participating in the formal exposition of arguments when cases were heard. The King also had his magicians and dream diviners (wagonezi, s. mgonezi), but these did not occupy official positions at the court.

## IV

The study of the place of Vugha in Shambaa politics presents an unusual problem to the student of social change, for the most important elements in the design of the capital could not be changed from one generation to the next. The people of Vugha insist that if the plan of the town, the construction of ritual houses, the house style, the species of wood used in the burial enclosure or the chichi house or any one of a large number of other elements had been changed, the kingdom would have been struck by misfortune. Depending on the element changed, the town might have been overrun in battle, or the land struck by famine. And yet it is clear that however static the forms of Vugha were, the organization of political action changed drastically from one generation to the next. The patrimony of Shambaa governmental forms could remain viable only if it met new challenges. I propose to examine, very briefly, the place of Vugha in Shambaa politics at three points, widely separated in time. The examples are familiar ones, for they were periods of rapid change in political relations. In those periods Vugha's role was bound to change, and by examining them it is possible to determine what kinds of change at Vugha were considered legitimate, given the rule that Vugha could never change.

The first period is the reign of Kinyashi Muanga Ike in about the last quarter of the eighteenth century, and the early years of the nineteenth. Up to, and including, the early years of Kinyashi's

reign, the kingdom included only territory which was within Shambaai, and only Shambaa speaking subjects. Vugha had taken its shape, in other words, as a symbol of the unity of all Shambaa within a Shambaa kingdom.

Kinyashi (p. 172), was the first ruler to extend the borders of the kingdom beyond the ethnic limits of Shambaai. He conquered East Usambara and Bondei, to the east of Shambaai. Yet even after Kinyashi conquered non-Shambaa subjects, he ruled from Vugha, which was constructed in the image of Shambaai. There were two problems which resulted from the conquest. First, given the fact that each King's representative at Vugha was the mediator between the capital and a portion of Shambaai, who would mediate between the capital and the eastern provinces? Second, the affirmation of traditional Shambaa culture in the construction of the houses and shrines led to an explicit exclusion of non-Shambaa elements. The Bondei had square houses with rounded corners, and Mamuongwana, the coastal people's section, was the only place where square houses were allowed. But this was outside the limits of the town itself.

The administrative problem was a simple one. There were two possible solutions. It is possible that the King's representatives for the eastern half of the kingdom, who lived in Kuyuwi, simply expanded the area of their activity from the eastern half of Shambaai to the eastern half of the kingdom, which now included the conquered

territories. A second possibility is that some King's representatives were added at this time. This seems somewhat more probable, for it would explain why there are only five stone seats at the clearing for cases, but eight major officials (the King, the Mlughu, and the six King's representatives). This interpretation fits the historical facts very closely indeed. The King sat, at the clearing for cases, with two stones for officials on either side, in a symmetrical arrangement. One of the stones, to the King's west, was that of the Mlughu, who was never the mlau (the official mediator) to any chiefdom. Thus there were two stones for walau to the east, and only one for the mlau to the west. This closely parallels the situation of the early kingdom, for before Kinyashi Muanga Ike there was only one chiefdom in the west, although there were at least two in the east (Feierman 1970: 102). The only puzzling discrepancy which remains is between the number of the posts of the great house (five, plus a center post), and all the other fives at Vugha. The Linga and the door of the great house had sets five undifferentiated parts. The clearing for cases had four chiefs' stones, plus one for the King.

The importance, at Vugha, of the patrimony of the Shambaa ancestors, was associated with the feeling that the Shambaa were the true subjects of the kingdom, even after the expansion. In the days of Kimweri ye Nyumbai (Kinyashi's son) the people of Bondei paid tribute to Vugha, but they were not protected from the extortionate demands of

their local chiefs, as were the Shambaa. And when a chief in Shambaai showed himself to be brutal, or incompetent, he was sent east.\*

The Bondei were exploited because their culture was a foreign one, and the kingdom, with Vugha at its center, was an expression of Shambaa ethnicity. It was not just a matter of the Shambaa on the one side being the early citizens, and the Bondei the later additions. The northern chiefdoms of Shambaai were also created in the reign of Kinyashi Muanga Ike, and yet the people of these chiefdoms suffered none of the disabilities of the Bondei. When the kingdom was weakened by dispute after the death of Kimweri ye Nyumbai, many years later, the Bondei fought to throw off Kilindi rule, and the people of the northern chiefdoms of Shambaai did not.

The form of Vugha did not change after Kinyashi's conquests in the east, but the place of Vugha in the context of Shambaa politics changed radically. And with the change of context came a change of meaning. In the earlier period the town had been a symbol of the unity of all Shambaa within a Shambaa kingdom. After the conquests, it became a symbol of Shambaa dominance in an ethnically diverse kingdom.

The second example is one of political action at a time when the distribution of power was changing drastically. As we have seen, in the middle 1860's, Semboja, a chief whose power was built on trade,

---

\*For a fuller description of the conquest and treatment of the Bondei see Feierman 1970: chapter iv.

challenged the authority of the young king, Shekulwavu. Semboja attempted to drive a wedge between Shekulwavu and the influential men of Vugha -- the Mlughu and the King's representatives.

The incident began when Semboja mistreated one of his wives, who fled to Vugha. Semboja demanded his wife's return, thus questioning Shekulwavu's power, and the dominance of Vugha. The chief minister and the King's representatives were anxious to defend the position of the capital. Shekulwavu felt that he was not strong enough to oppose Semboja. He returned the woman, and lost the support of many of his own officials (Feierman 1970: 150-151).

The presence of refugees was a sign of the King's power, and it augmented his power, for the refugees knew that if the King lost Vugha, they could be retaken by their chiefs. What Semboja did, by challenging the rule, was not to attack the place of Vugha in Shambaa politics -- he later tried to take Vugha for himself -- but to bring into question, among the men of Vugha, Shekulwavu's ability to serve as a true King. The refugees, as a symbol of power, were not associated indiscriminately with any Kilindi who occupied Vugha. In effect, they were a threshold mechanism: if the King did not have sufficient support from the officials of Vugha, from armed Shambaa, and from a number of his chiefs, he could not give refuge. By refusing refuge, he dissociated himself from the symbols of power at Vugha, and showed the lack of identity between his person and his office.

A second threshold mechanism operated at those times when Vugha fell victim to fires. The crowded houses with their grass rooves burned easily, and a spreading fire was difficult to stop. After the capital was burned in the succession war in 1868 it was not rebuilt until Kimweri Maguvu had been made king of Vugha. His Mlughu ordered the former inhabitants to return, and to rebuild their houses, as a matter of state. There were two fires at the turn of the twentieth century, at a time when King Kinyashi had been discredited as a result of his cooperation with the Germans. Some men at Vugha maintain that at least one of these fires was initially a minor one, and that the inhabitants encouraged its spread, presumably because they were angry at being sent by Kinyashi to work on German settlers' farms. In the destruction of the capital in 1868, and that of German times (the only two recorded instances of the destruction of the capital), the number of houses built at the capital after the fire was regarded as a visible sign of the King's importance. This was related to the number of men he could convince or compel to build again.

The final example is drawn from the 1870's and 1880's, after Semboja had made his son, Kimweri Maguvu, King of Vugha. Kimweri Maguvu and Semboja drew a significant part of their support from trade, and from allies outside Shambaai. They were above all cultural and economic innovators. A missionary who met Kimweri Maguvu, when he was away from Vugha, reported that the King had worn, for the meeting,

a suit of European clothes, a sun hat, and patent leather shoes.

Kimweri asked the missionary for pepper seed, curry powder, petroleum, coffee seed, and the seeds of European fruit trees (Feierman 1970: 196).

But the same King, who saw it as his job to sponsor change in Shambaai, was careful to have the houses of Vugha built according to the pattern of the earlier Kings. The unchanging town of Vugha was too important a symbol of sovereignty among the Shambaa to be altered. The King made no attempt to bring large groups of traders to Vugha, and commerce was concentrated at Semboja's Mazinde. In Mazinde, the image of Vugha was turned inside out: the court at the center of the town consisted of square coastal houses, and the round houses of the subjects encircled them (Feierman 1970: 194-195).

Given the unchanging quality of Vugha's forms, there were two possible courses of political change. In one, as shown in the expansion of the kingdom, it was possible for Vugha's content to change, while its forms remained the same. But there were limits to the flexibility of Vugha. In the late nineteenth century, it could not be both an enclave of insular unchanging Shambaa culture and an innovative trading town. The response of the Shambaa political leaders to this second, more extreme, kind of change, was to allow the role of Vugha in Shambaa politics to shrink. Vugha was the location of the ancestor shrine, but Ubi had the rain magic, and Mazinde was the

trading capital.\* In this period, in a time of rapid change, Vugha could not change, and it did not die. It had been a microcosm of the whole of the Shambaa kingdom, but now it was merely a special centre of traditional political practices -- one political centre among many.

---

\*There was no structural reason trade could not have grown important near Vugha. Mazinde became the trading town because of its location -- because it was near the major trade routes. If Vugha had been well located for trade, it could have developed like some of the medieval European towns, its old town side by side with a new one. At Ratisbonne, as at Strasbourg, the 'city of merchants' arose beside the episcopal city. At Verdun the traders built a fortified enclosure joined to the city by two bridges (Pirenne 1956: 101). The argument here about the shrinking role of Vugha would not need to be altered if this had happened. It would be necessary only to talk of the shrinking role of the old town, rather than the shrinking role of Vugha.

## FOOTNOTES - CHAPTER SIX

<sup>1</sup>Burton 1872: II, 229. LangHeinrich estimated the population at the end of the century as 2000 (1902: 76). It is clear that Vugha declined after the death of Kimweri ye Nyumbai, in 1862. LangHeinrich noted in his diary that the overgrown paths near Vugha, which were being cleared by government order, had been 1 1/2 meters wide in the day of Kimweri ye Nyumbai (Bethel MS, Tagebuch Wuga: 22 June 1896).

<sup>2</sup>Sangai gives three species for mvumo: Ficus leprieurii, F. natalensis, and F. thoningii (1963: 69).

<sup>3</sup>Sangai (1963) gives four species of Ficus which are all called mkuyu. Since the tree is no longer there, it is impossible to know which of these the relevant mkuyu was: Ficus capensis, F. mucosa, F. sycomorus, or F. vallis-choudae.

<sup>4</sup>Mila is used somewhat more frequently today than fika. I have taken mila to be a recent introduction because it is a Swahili word of Arabic derivation, used to indicate a concept which clearly was in use long before heavy Swahili influence on Shambaa religious thought, and because it is not given in LangHeinrich's dictionary (1921) or, to the best of my knowledge, in Roehl's grammar (1911). Fika is given in LangHeinrich.

<sup>5</sup>K. Wohlrab (1929: 30). Wohlrab named the tree as king'wele, which is not in Sangai. My own informants, however, used the names king'weng'we and king'wele interchangeably.

<sup>6</sup>When the King held a private ritual in the great house, other Kilindi could attend, although they could not be present at public rituals in the burial enclosure.

## CHAPTER SEVEN

### LITIGATION, WARFARE, AND TRIBUTE

The existence of the state impinged upon the practical concerns of subject lineages in four ways. First, cases were heard by the chief or sub-chief and his commoner advisers at each local capital, as well as Vugha. Disputes between subject lineages were settled; witches and other threats to public order were dealt with. Secondly, tribute collectors visited the villages to take livestock for the political authorities. Commoners were also expected to contribute food and labour to their local Kilindi court. Thirdly, each localized common lineage was expected to send fighting men in time of war. In return, the forces of the chiefdom defended the subjects within the territory from attack. Finally, the King and chiefs made magic for the fertility of the soil. Virtually all Shambaa believed (and the overwhelming majority believe today) that the quality of political leadership, together with the quality of the leader's rain charms, determined whether there would be famine or plenty at any particular time.

Three of the four links between the state and commoners -- litigation, warfare, and tribute -- are discussed together here because the administration of each varied according to whether a chief was dominated by the King or competed with him. A chief who was dominated by the King paid tribute, came to the help of the King in war, and could not impose a settlement by force in an interlineage dispute but rather

sent the case on to the court of the King. On the other hand, any chief who competed with the King and retained independent power imposed settlements in interlineage disputes himself, did not need to help the King in war, and did not pay tribute to the King. The relationship between King and chiefs varied according to the descent relationships between them, and according to the distribution of power. If the King had been able to remove earlier chiefs and to put his sons in their places, he invariably dominated the new chiefs. If, on the other hand, the chiefs were of the King's own (or a senior) generation, then the regulation of relations with regard to tribute, litigation, and warfare, depended on the power relations between the King and each individual chief. The way in which this worked will be described below.

In the administration of the kingdom, in other words, there was not a single pattern with chaos as its alternative. There was a range of variation. Implicit in indigenous descriptions of administration are a pair of conditional statements: if the King was strong one thing happened, if weak another, but in both cases there were complex interconnected sets of expectations. And of course there were transitional states. Much of this has already been described in the study of the alternative configurations of the descent relations between King and chiefs (chapter **iv** ). The patterns can only be understood fully, however, if one examines the functions of chiefship. The relatively low level of functional specialization made it possible for administrative patterns to vary in a way which would never be possible in a modern bureaucratic state. Yet without a specialized staff, a strong King's

orders were obeyed throughout the kingdom.

The study of the fourth practical political concern -- fertility magic -- is reserved for the next chapter because the conceptions by which Shambaa explain famine and plenty also describe, and place a relative value on, administrative configurations. Fertility magic is only marginally a set of administrative activities, in the sense that the hearing of cases and the collection of tribute are activities. This chapter, in other words, is a study of sets of activities and the special conceptions associated with each major set. It will be followed by a consideration of political ideas with more general and pervasive applicability.

## I

The nineteenth century Shambaa word we would translate as judge is mulamuzi (Steere 1967: 10), a gerund of the verb kulamula, or kuamua, meaning to mediate -- to reason with two sides in a dispute. One proverb of the period is, Weomana ni waili, mulamuzi ni ywa ntatu: 'There are two who fight, and the mediator is the third' (Johanssen and Döring 1914-1915: 222). Disputes within a maximal lineage were usually settled by members of the lineage. Compensation for injuries could not be paid by one lineage member to another. The cases which a chief and his courtiers heard were, almost without exception, disputes between members of two maximal lineages. Litigation was initiated, even in matters of theft or most cases of murder, by the lineage of the injured party, which made

a complaint to their chief, or to his court officials, against a member of another lineage. This was a formal process with its own vocabulary. -Fyalima means to issue a formal complaint, which leads to a masa (singular and plural), a court case.<sup>1</sup>

In almost every interlineage case, a decision was made on whether livestock should be transferred from one lineage to another. What was at issue, in most cases, was whether one person had in some way injured another, whether by beating him, stealing from him, sleeping with his wife, accusing him of witchcraft, or murder. For each type of injury there was an appropriate payment in livestock. The livestock, called maliho, or 'the payments,' were seen as compensation by members of one lineage to another, and not as a fine, although the man who received the payment was expected to give part of it to the chief, and in some cases to the court officials, because without the chief's court he could never have settled the case. I have no way of knowing what would have happened to the winner of a court case if he had not 'freely' given the chief some of his compensation. The chief would certainly have had the right to collect the same livestock as tribute, with less good will than if it had been given 'freely.'

Given the fact that in the Shambaa view the primary purpose of the chief's activities in his capacity as judge was the regulation of relationships among maximal lineages, there are two major areas of concern for an understanding of the place of litigation in Shambaa political life. The first has to do with relationships among chiefs as seen through the eyes of litigant lineages. What was the relationship between the court of a sub-chief and that of a chief, or between the chief's court and

the King's? There was great emphasis on the mediation of disputes; at what level in the hierarchy of courts did mediation leave off and judgement begin? Secondly, the regulation of interlineage relationships through litigation helped to define the characteristics of the lineage. Since litigation was settled by the transfer of wealth from one lineage to another, it is important to know what happened when a lineage had insufficient wealth to meet its legal liabilities, and how conflict within a maximal lineage was resolved. The two major areas -- relationships between lineages within the hierarchy of courts, and the characteristics of lineages as defined through litigation -- will be discussed in order.

The primary purpose of any court hearing, from the court of the lowest sub-chief to that of the King, was to convince one of the two litigants to accept the weakness of his own case and admit defeat. -Vota means to win a court case or any other contest; -voteka means to confess one's own wrong, or to accept defeat. When one litigant said, nzavoteka, 'I have accepted defeat,' the case was over. All cases except for those involving murder or rebellion began in courts at the lowest level, that of the sub-chief. If the apparent loser of the case resisted the arguments of the officials and the evidence they cited, and refused to accept his defeat, the case went on up to the chief, and possibly to the King. The case would end with either an admission of defeat or a settlement 'by force' at the appropriate level (described below).

At the court of a sub-chief, or of a chief, those who heard cases included the Kilindi himself, and his court officials (watawa, s. mtawa,

as opposed to the King's representatives -- wafung'wa). The most important of the officials, equivalent at a chiefly level to the Mlughu of the King's court, was the Mdoe. Other officials were the Sheshe, the Mbilu, and sometimes the Mwambashi. Court organization at this level was not as intricately articulated as that at Vugha. There were not, so far as I know, quarters in the local capitals, or separate territories assigned to the court officials. The court officials were responsible for all the business of the chiefdom or sub-chiefdom, and not only for the hearing of cases.

After a case had been prepared, and the chief forewarned, the individual litigants most directly involved would come with members of their lineages, and all would meet together with the chief or sub-chief and the court officials. The hearing of a case began with the presentation of the complaint. The defendant answered with his arguments. Court officials could question both litigants, as well as the witnesses (waona, s. mwona) who were brought by them. The officials could summon additional witnesses if they chose. There is no doubt that while evidence was carefully presented, and precedents cited, a litigant with friends among the officials felt more certain of getting a sympathetic hearing. There was a proverb, Mmasa mwena mguha nkakuntwa ni moyo, 'If a litigant is received by an official, his heart does not thump with fear' (Johanssen and Döring 1914-1915: 221). When the arguments were being set out and the evidence presented, the more minor officials did most of the questioning. The chief did not participate actively until time to announce the court's decision.

The normal style of Shambaa conversation was considered inadequate for arguing cases. There are no monologues in Shambaa discourse. If one individual is speaking at length, he stops in the middle or at the end of virtually every sentence. During the pause, the listener says Ehe mosiye, 'That's right, my friend,' or some similar phrase. Shambaa use a great many proverbs in ordinary conversation, and even more in court cases. Most proverbs are divided into two parts. The speaker gives the first part, and his listener provides the bontokeo -- the conclusion or meaning. Thus one person might say, Mlonga masa -- 'He who argues a case.' He would expect someone else present to say ufanyanye na ya kale -- 'he should think of former ones,' that is, remember precedents. One of my informants explained why this style of conversation is inadequate in cases: 'If this person responds conversationally and that person responds it is no good at all. It becomes impossible to listen carefully to the arguments.' The habit of conversational style was so deeply rooted, however, that litigants needed some response to their arguments, someone to provide the conclusions to proverbs. This was the job of the kiuzio (or kiluzilo), the man who at other times made public announcements for the chief and his officials. The kiuzio responded with equal enthusiasm to the arguments of both sides. He also called for order when necessary, and provided comic relief by announcing from time to time that what really interested him was mtwi na ulaka -- the skull and jaw of the goat which would be killed to feed the court officials. The kiuzio was given the jaw in return for making

court's responses.

As the arguments progressed, the officials would try to convince the litigant who seemed to be in the wrong to admit defeat. There was considerable pressure on him to do so, even if he was not convinced of his own guilt, for the court costs would mount if he insisted on carrying his case to higher courts, and he might even get a reputation as a man who resisted authority. The amount of compensation could be increased to discourage frivolous appeals. After all the arguments had ended the officials would present their summations of the case, beginning with the lowest official, and proceeding through the Mdoe (or at the royal court through the Mlughu) to the chief. The word of the chief (or sub-chief or King) superseded all previous judgements, although a chief could become unpopular if he decided that an individual was guilty whom the court had found innocent. If the chief was absent, the Mdoe (or at Vugha the Mlughu) could conclude a case. If both the chief and the Mdoe were absent, cases could not be heard.

The loser of the case made the payment called mvumo, for the court officials. This was one goat, which was slaughtered to provide meat. It was considered a court cost, separate from the main payment assessed as compensation. In most chiefdoms, cases were heard under an mvumo tree, because it provided cool shade, and because of its symbolic qualities (see pp. 271 and 318).

In cases where some of the facts were in dispute, as in allegations of theft from an unoccupied house, an additional goat, called ughoe ('the rope') was paid. The meat was roasted on the spot, and the loser of the

case was made to eat a piece along with all the other men involved, to show that he accepted the outcome of the case. Once he ate the meat he was unable to resort to muna -- an oath which was thought to result in the death of the man whose case was based on falsehood. It was in the interests of both lineages to see that the meat was eaten, for muna was thought impossible to 'cool' adequately; it could lead to an indefinite number of deaths within the maximal lineage. One of the benefits of the chief's court, as seen by the Shambaa, was that it became possible to avoid drastic mystical sanctions through the presentation of evidence and the citing of precedents. The removal of witchcraft cases from the legitimate business of the courts, immediately after the German conquest, was accompanied by the first known use of witchcraft eradication medicines in Shambaa history. Mystical sanctions were used by autonomous Shambaa courts only in a preventive, not a punitive, manner. If two men came before a chief's court, each accusing the other of sorcery, each was made to take an oath that if after that time he used sorcery against the other, he would die.

If both litigants refused to admit defeat, the case moved up through the courts of superior Kilindi until it reached a court where judgement could be made 'by force' (kwa nguvu), rather than through mediation. The court of such a chief was called he nguvu -- the place where force or power is located. I shall consistently translate he nguvu as 'the locus of power.' Depending on the political situation at any given time -- depending on the descent configuration of the royal lineage, and on the sources of support of the chiefs and King -- a number of chiefly capitals could be loci of power, or Vugha could at times be

the only locus of power. The Shambaa can describe the varying relationships between King and chiefs with great precision by referring to the number of loci of power. At a time when there were many competing chiefs and no dominant King there were many places called he nguvu. When the King dominated his chiefs only Vugha could be described as the place where power and force were located. In all instances where a chief could impose a judgement by force, he could also make war independently, and refuse to cooperate with the King in war, and he could refuse to make tribute payments to Vugha.

While there were a great many possible variations in the relations between King and chiefs, and in the distribution of loci of power, there was, when seen from the point of view of a subject, only one place at which a judgement could be imposed by force at any one time. That place could be a nearby chief's capital at some times, the distant royal capital at others, but no subject was ever concerned with more than one locus of power. The existence of such a locus indicated the existence of an autonomous territory, capable of fulfilling all the functions of sovereignty.

The account given here of the variability of enforced judgement was built on informants' accounts which at first seemed contradictory. Some informants, when asked about the enforcement of judgement, said that only at Vugha could a case be decided by force rather than through mediation. When asked for examples of chiefs who would send cases to Vugha, these informants usually cited examples from the days of Kimweri ye Nyumbai, who installed his sons in all of the chiefdoms. Other

informants said that most major chiefs could judge cases by force. They gave examples of chiefs during the reign of Kimweri Maguvu (two reigns after Kimweri ye Nyumbai) -- a time of competition and conflict. But even during the reign of Kimweri Maguvu there were some chiefs who could enforce judgement themselves, and others who could not, depending on the relative power of the King and each chief. It is clear from local oral traditions, for example, that during the middle to late 1880's (the second half of Kimweri Maguvu's reign) the chief of Mlalo imposed judgement by force, while the chief of Gare sent cases to Vugha, for Gare was not a locus of power. Both chiefs were the King's father's brothers' sons, but in the case of Gare, Maasai raiders sent by the King had killed the chief's father, while at Mlalo the local Kilindi had successfully fought against the King and had escaped the domination of Vugha (see pp. 203f). Not all accounts of litigation were fragmentary. Informants gave coherent accounts if one asked about the variability of Kilindi descent configurations, or if one asked about the meaning of such terms as he nguvu. It was also possible to get full and subtle statements about enforced judgement by phrasing questions in conditional terms: if the chief was the King's son, could the chief enforce judgements?

Cases of murder went to the locus of power immediately, without being heard first by lesser chiefs. In a murder case it was the chief's task to decide, depending on the circumstances of the murder itself (whether it was of a kind which provoked a sense of moral outrage), and the resources of the murderer's lineage, among three possible judgements.

He could have the murderer put to death. He could assess the large payment called kimba -- 'the corpse' -- as compensation to be paid by the murderer's lineage. Or he could pay at least part of the kimba himself and keep the murderer at the capital. Murder cases went immediately to a locus of power because it was only at such a place that the chief had the authority to put a person to death.

There was an extraordinary economy about the enforcement of the law in Shambaai. In most cases the litigants were expected to compose their differences voluntarily, with the help of officials. But the mediation of sub-chiefs and of those chiefs who did not govern loci of power would have been much less effective if there had not been one place for every territory where a settlement could be imposed by force. The authority of chiefs at all lower levels depended ultimately on the capability of the chief at the locus of power to put murderers to death. This was the full meaning of the mvumo tree, under which cases were heard. I have already shown (p.271) that the mvumo was a liana which killed its host tree, and therefore symbolized the King's characteristics as a killer. It was also a tree known for its cool peaceful shade, in which cases were heard. The cool of the shade was like the peace of the land which resulted from the settlement of cases. Without the mvumo's capacity to kill its host, there would have been no shade. Without the authority of a chief at a locus of power to kill his subjects there would not have been peaceful settlements. There is a proverb which expresses this ambivalence, as seen by a litigant: Nyumba nkuu honelo kangi komelo; 'the great house saves because it kills.'<sup>2</sup>

Cases of the repeated and habitual practice of ushai (witchcraft or sorcery) were exceptions to the rule that only a chief at the locus of power could condemn a subject to death. These cases were special because they did not involve litigation between two lineages. They involved the action of an entire community against an individual. If someone was suspected of the habitual practice of ushai, a large group of the witch's neighbours, drawn from a number of lineages, would attack the witch's village, and tear down his house. They could either kill the offender, or take him to the chief. The unanimous judgement of the witch's peers was strong enough justification for condemning a witch to death, even at a court which was not a locus of power. The chief could have the witch put to death (usually by having him clubbed and thrown off a precipice), or he could decide to allow the witch to live at the capital. If a witch escaped from his attackers, he could take refuge at the court of a chief, and build his house in the chiefly capital.

Once the witch took up residence at the capital, he was put into the position where, if he wanted to continue practicing witchcraft, he could do so only by attacking the chief, for the town was the chief's. In an ordinary village, a witch attacked one lineage after another until the entire village, or cluster of villages, was in danger. The lineages were endangered because each one acted separately, except for the rare moment when a threat was so evident that they banded together to 'hunt' the witch (-ingata) as they would band together to hunt a wild animal preying on livestock. The chief, on the other hand, possessed

the greatest, most concentrated, collection of magical charms in the chiefdom. By allowing a witch to live at his town, the chief proclaimed that he was the witch's equal as a magician. If the witch violated the law after he moved to the capital, the chief was free to kill him, or sell him as a slave, this even if his town was not a locus of power, for the chief was the embodiment of the unity of his people, and the people unified could legitimately hunt out witches.

Maliho, the compensation paid from one lineage to another after a court case, was but one of a number of types of transaction between lineages involving wealth (mai or mali), the exchange sphere in which livestock was the most important good. The other uses of wealth were, as we have seen (p. 94 ), directly connected to the preservation or procreation of life -- to the maintenance of living individuals within a descent group. These uses included the purchase of food in time of famine, payments for a medicine man, bridewealth, and rites of passage and sacrifice. 'Wealth,' in this sense, was masculine property associated with a patrilineage, and necessary for a man's response to the threats which faced his descent group. Ukiwa meant poverty, but it was related to the verb -kilwa, to be overcome by difficulties. In addition, wealth was seen as limited in quantity. There was not the peculiar view of modern commercial men that the greater the number of transactions, the more wealth increases. Thus when one lineage paid a considerable amount to another in compensation for a breach, it was surrendering to the other a part of its own vitality.

The transactions have been described here as taking place between

two lineages because it was impossible for such a transaction to take place within a maximal lineage. In fact the payment was usually made to the man who suffered a loss as a result of the breach (the father of a murdered man, the husband of a woman with whom adultery was committed), and the payment was made by a maximal, medial, or minimal lineage, depending on the circumstances. (The variability of the compensation paying group is discussed on pp. 88ff.)

The amount of compensation naturally varied according to the seriousness of the offence. In some cases, especially with murder, the amount was varied somewhat according to the wealth or poverty of the offending lineage. Kimba, 'the corpse,' the payment for murder, was between ten and fifteen head of cattle, of which about five were given to the chief, who then gave part of his share to the court officials. The compensation for adultery (ugoni or ubughe) was two cows and a bull calf, of which the chief would get one cow. For the offense called 'the spoiling of young manhood' (kubania ubwanga), which was a permanent deforming injury resulting from assault, the compensation was two cows and a bull calf. In such a case the chief took little or nothing, for the compensation was meant to help the young man get a wife despite his injury. The compensation for theft depended on whether it was house theft or farm theft. There was disagreement among my informants over the distinction between the two. House theft included the theft of any domestic animals or fowl, and any utensils or iron implements taken from the house. There is disagreement over whether food taken from a house was seen as farm theft, and whether implements

taken from a field were house theft. At any rate, house theft was a much more serious offense, compensated by two cows and a bull calf. The compensation for farm theft was two nanny goats and a billy goat. Several reasons are given for distinguishing the two categories of theft. A person may steal food from a farm because he is very hungry. Anyone can experience extreme hunger. The things stolen from a house are kifu -- patrimony, and therefore to be taken seriously. In addition, the Shambaa economy depended on most people leaving their villages every day to go to distant farms. A person would show that the house was unoccupied for the day by tying a rope from the door to the nearest part of overhanging roof, so that neighbours would notice if strangers entered. The heavy penalties against house theft were meant to discourage potential thieves, and keep unguarded houses secure.<sup>3</sup>

The requirement that after a breach of the law, a member of one lineage would be made to pay compensation to a member of another, led to a definition, in Shambaa action, of the limits to the ability of the separate lineages to continue in existence, and to sustain members. If a man could not command the support of his lineage, or if he or his lineage did not have sufficient wealth to pay compensation, the shortage of wealth was directly converted to a loss of lineage members. If an individual could not pay compensation, the chief paid for him and took as watung'wa (s. mtung'wa ; slaves or pawns) as many of the litigant's dependents (and possibly the litigant himself) as were necessary to compensate the chief for his expenditure.

There were established equivalencies between slaves and livestock.

My informants disagreed with one another on the precise equivalencies, and there is disagreement between the informants' reports and the one written account which gives prices (LangHeinrich 1903: 241). A girl slave was equivalent to three or four head of cattle: some said two cows and one bull, other three cows and no bulls, LangHeinrich wrote simply four head of cattle. All informants acknowledged that a young man was worth less -- either two or three head of cattle: one cow and one bull, or two cows and one bull, or three head of cattle, undifferentiated. The most frequent statements indicated that any slave was worth three head of cattle, but that for a girl slave a larger part of the payment was in cows, which were worth twice as much as bulls. Thus if the chief took responsibility for a homicide payment of twelve cows, he took four of the murderer's dependents as slaves.

The men of a lineage would usually try to give young dependents as slaves or pawns, so that the grown men could work to collect livestock for compensation, and so ultimately redeem their people. If necessary, the men could give the chief their married daughters, but they could not pawn or enslave their wives, or their sons' wives.

There were a number of ways in which individuals became slaves of the chief, other than through the chief's payment of compensation in a court case. Prisoners of war (nkoe or mateka) were slaves. In famine, a man could pawn his children to the chief in return for food, and redeem them with livestock once the famine was over. In such a case the chief would be expected not to sell the pawns. In cases of long standing debt, the creditor could resort to self help, and seize as

many of the possessions as possible of the debtor. The chief would then pay the debt, the possessions would be returned to the debtor, who would pay back the chief or give pawns. According to Karasek (1918-1922: 81-82), a child of an adulterous union, who could not belong to the lineage of its mother's husband or of its genitor, became a slave of the chief.

In all these cases, individuals without adequate lineages were grafted on to the house of the chief. This was the way in which a society of responsible lineages was maintained in spite of unpredictable occurrences which led to the decline of individual descent groups. I have argued in chapter iv that while, in the Shambaa view, a chief could take all the wealth of the land, he could not arbitrarily take people from their own lineages. Slavery was one way for the chief to convert his material resources into living dependents. The chief's potential ability to do so at a locus of power was enormous, for it was he who imposed judgements and required that compensation be paid. One former King's representative explained this, in a phrase precisely the same as one Krapf quoted more than a hundred years earlier (1964: part 2, 291); Washambaa toshe ti mateka; 'We Shambaa are all slaves.' The former official went on to explain that this was because there was a single person who enforced judgement.

The treatment of deviant behaviour as an offence by one lineage against another, with slavery as the status of members of failed lineages, left the regulation of offences within a lineage to its members. At the same time the extent of the descent group's joint responsibility

made it imperative for the group to control the behaviour of its own members. There is a proverb: Mkiau mwe tuni, atozighwa ni ndughu; 'a crazy man with a knife, is seized by his own kinsmen.' Serious violations within the lineage and repeated violations against other lineages were treated in the same way. If the violator's father was alive, he would go to the chief with his son and with a bull. He would give the bull to the chief, with the words, 'Here is a club with which to kill my son.' The son then became a slave of the chief, who would be responsible for the payment of any compensation in the future. I knew one man who, after repeated family fights about twenty years ago, was given by his father to the King. The man remained at Vugha, and after every change of government, performed menial tasks for the new officials at Vugha. When I left Shambaai he was still at Vugha, living an unchanged life. It was clear that he was not being held against his will; he could easily have gone off to live in a town. But that would have meant insecurity -- finding a job, finding food. Minor infractions within the lineage (and also between lineages) were settled by the slaughter of a temo -- a goat offered by the individual at fault, which was killed and eaten by both individuals or groups to show that harmony had been restored.

The status of a slave was not onerous. Young slaves lived in bachelors' houses at the capitals of their possessors. They lived together with the free bachelors, and had no special supervision. An unmarried slave was expected to spend much of his working time farming for the chief. The slave would be attached to the house of a wife of the

chief. She would cook his meals, and be addressed by him as wau -- grandmother or elder sister. The chief himself was addressed as baba -- grandfather or elder brother. When the time came to get married, the slave would build himself a house in the capital, and would be given a wife by the chief. The children were slaves, but the slave who was their father was entitled to one half his daughter's bridewealth. If a slave woman married a free man, he paid three cows for her redemption instead of bridewealth, and she was considered a free woman, although she would be made to endure the insults of her co-wives, and would lack the protection from her husband which a wife normally received from her brothers. Her sons had a full share in their father's patrimony, although he did not pay the cow of affinity for her (see pp.107f), and so they lacked their share of that cow's offspring.

A slave could own property. He did not give up the farms he owned at the time of his enslavement, and could continue to farm them for his own profit. His children would inherit the farms. A slave, at least in the 1880's, could be killed or sold at the wish of the chief. The chief was responsible for the payment of compensation if the slave violated the law, and if the slave was murdered, the chief was the recipient of the payment from the murderer.

Slaves could at any time be redeemed by their kinsmen, and it seems that a slave could slowly accumulate wealth by farming his own land, and pay to redeem himself. A slave who distinguished himself by long and faithful service at the court -- one who became a court official, for example, could be freed at the word of the chief.<sup>4</sup>

## II

Nkondo is defined as any conflict in which men are or might be killed. Raids for cattle were called nkondo, as were the small battles between the men of a village and kidnappers, and as were the large scale conflicts between the massed forces of chiefs. I am translating nkondo here as 'war.'

The Shambaa recognize several causes for war. The competition between the King and a rival who had established a competing kingdom with the intention of ultimately taking Vugha took the form of warfare. These cases of the creation of a 'separate' Kilindi 'power' (nguvu ntuhu, see p. 174 ) were the only instances in which Shambaa chiefs with Shambaa fighting men could legitimately make war upon one another. Any other competition between Kilindi had to be carried on by subterfuge.

A second cause of war, one which frequently provided a cover for forbidden battles between chiefs, was the desire to take cattle or slaves from non-Shambaa, and the attempts of non-Shambaa to take cattle from Shambaa. Maasai, Kamba, Taita frequently raided in Shambaa, and the Shambaa raided in return against them, and against the Mbugu of the high forests and meadows of the central mountain area. When Kilindi chiefs wished to make forbidden war against one another, they invited non-Shambaa to raid Shambaa, provided guides and battle plans, and allowed the raiders to keep much of the booty.

I have already described the political situations in which this sort of dissimulation occurred (p.206). Shambaa described this sort of activity as the result of njama -- secret plotting.

The final major cause of war was ubelo (or ubezi) -- insulting or deprecatory behaviour by a non-Shambaa chief toward the Shambaa King. One Kilindi explained the meaning of ubelo when describing the war between Kimweri Maguvu and the Zigula chief Kihungwi in the 1880's. He said, 'The cause of war (kisa) was ubele. When Kimweri gave instructions, Kihungwi did not respond. And he refused to send tribute to Vugha.' Thus the refusal of a chief to recognize Vugha's domination was seen as an insult against the King. The King's war of domination was described in defensive terms, as the response to an insult.

Only the King could be insulted by deprecatory behaviour. A chief, even one at a locus of power, was not usually expected to take the offensive against foreign political leaders. In spite of this, there were significant differences between the position of chiefs at and away from a locus of power with regard to warfare. A chief at a locus of power was expected to take vigorous action in defence of his own independence. If the King or any Kilindi chief attempted to collect tribute, or to install a replacement, the chief was justified even in making war against the King. This could be done with relative ease when there was a separate Kilindi power which the chief could aid in battle. Many chiefs at loci of

power undertook vigorous and extensive cattle raiding, to a point approaching regular domination of the non-Shambaa who were raided. The crucial difference was that cattle raiding was intermittent, and there was no expectation that regular payments would be made, as they would in tribute relations between non-Shambaa and the King. A chief at a locus of power could also refuse to send men along with the King's army, even when the King was fighting against the splinter kingdom of a rival Kilindi power. On these occasions any chief who was not at a locus of power, (and not subordinate to such a chief) was required to send fighting men with the King.

\* \* \*

War was an unusual situation of uncertainty in the life of a Shambaa man. Death in war was one of the very few kinds of death which were accidental, essentially unpredictable. Most other deaths could be attributed to the action of a malevolent individual, or to the weakness or state of pollution of the person who died (pp. 69ff). War was different from other causes of death because it was possible for any number of unrelated men to die at the same place and the same time. While it was easy to find a moral cause for the deaths of three related people in a village where disease spread, the capricious nature of death in war was much more evident. The closest similarities were with death as a result of mountain floods, which could wash away a line of villages, and leave others nearby untouched.

It is for this reason, I would suggest, that water imagery is so prominent in Shambaa descriptions of warfare. One chief is described in an oral tradition as refusing the King's ultimatum, and inviting the opening of hostilities, by saying, 'Let him [the King] break the dam so that water runs down onto this mountain.' The idiom for describing an end to hostilities is, nkondo itahwa, 'the war dries up.'

While acknowledging that the outcome of war and its effects on individual lives were uncertain, the Shambaa attempted to reduce its uncertainty through a great variety of divinatory and protective rites. Chiefs and prominent warriors were continually casting about for new and powerful weapons and magical charms.

Shambaa weapons of the late nineteenth century, which included front loading and breech loading firearms, war clubs, spears, and bows and arrows, are described excellently and in great detail by Karasek (1913: 78-95). Weapons are in a separate category from war magic. They are called mata, the augmentative plural form of the noun uta, bow (pl. nyuta). Weapons changed in the nineteenth century, with a rapidity which seems unusual for Shambaa technology. Not only were firearms introduced, and each new technological advance from Europe eagerly accepted, but at the same time a number of new spear designs were adopted (Karasek 1913: 81).

There were two kinds of rites associated with warfare. There were, first, those rites called fika -- rites which came down to

the living from the ancestors as a patrimony, and which were not expected to change. Secondly, there were the rites associated with the use of magical charms (hiizi), the purpose of which was kuzindika -- to protect the wearer or user from harm. New protective charms were eagerly sought, and the Shambaa were as eclectic in their use of new charms as they were in their use of new weapons.

The most important of the rites which came from the ancestors was fika ya nkondo ya muamo, the divinatory war rite. I did not succeed in collecting enough authoritative accounts of this rite to be certain of all its details, but I can sketch its rough outline. The purpose of the rite was to determine which, among the potential fighters, were unsuited to go to war: who, in the accidents of war, would be certain to die. In addition, a sacrifice was offered to the Kilindi ancestors. The rites were performed after a chief's men had been defeated several times in war, or when a difficult battle was expected. There were two methods described, in the written and oral accounts, for divining which of the warriors were unfit. According to some accounts, both methods were used in the divinatory war rite.<sup>6</sup>

In one of the methods the unmarried young men of the chief's capital were divided into two groups. Each group was given women.<sup>7</sup> The groups were armed with sharpened sticks. They fought one another, pushing back and forth until one group was considered defeated. The women were taken from the defeated group, then a goat or bull was

slaughtered and everyone ate. At Vugha there was one battle between the young men of Kwe Mula (the western half), and another between the young men of Kuyuwi (the east). Each group of young men was associated with a group of adult fighting men. The men associated with the defeated group were not allowed to go to war, where, it was believed, they would meet certain defeat. Of those associated with the victors in the mock battle, the most that can be said is, that, in the words of a former King's representative, 'When they go to war, they might win, or they might lose. The important thing is that they perform the rite.' It is possible to know those who would be defeated, but victory is never certain. When I insisted, to the King's representative, that there must be some way to know who will win a battle, he replied with a proverb: Utaia ukweawa nako, miya ukweita hukutaia; 'You know where you have come from, but it is impossible to know where you are going.' This is especially appropriate in relation to the divinatory war rite, which determines where you have come from, because it interprets the wishes of the ancestors who may make it impossible for you to survive in battle, but it cannot predict your success or failure against the enemy.

In the other method of selection, the King's or chief's great wife dipped her forefinger into powdered medicines, and marked the forehead of each fighting man as he ran past. Any man marked on the right side was able to go to war. A man marked on the left

stayed home. In Riese's description of the rite, this marking took place before the mock battle. According to some oral accounts, the marking of the fighting men was not a part of the divinatory war rite, but simply part of the administration of the protective medicines.

While the fighting men were being chosen, the King or chief went to the grave site with some of the officials. They took with them a black bull, and a black sheep. The King invoked the ancestors, and then slaughtered the animals, leaving some pieces of roasted meat and some cooked staple for the ancestors.

Another inherited war rite, this time a purely defensive one, was described by only a single informant. But he was a very old man, a Kilindi of Ubii, the son of Mtoi (chief of Ubii in the 1880's). The informant had himself taken part in the rite as a child. In this rite, which took place after the death of a chief, a cow was led around the carefully marked boundaries of the chiefdom. On the cow's return to the chief's capital, a bell was hung around its neck. The ancestors were invoked, and a bull was slaughtered, but the cow was left to live and to give birth, as a symbol of the continuity of the chiefdom. The rite was performed for the security of the borders.

An additional rite took place at chichi, the King's house of war magic, whenever the King went on a dangerous trip, or when he was planning war. The King would tell the keeper of chichi to inform the ancestors of the journey. The keeper would take a gourd

with water in it, and pour some on the floor, naming all the ancestors, informing them of the King's plans, and asking them to sleep. The invocation ended with the word kagonei: 'may you sleep.' What was sought was not the assistance of the ancestors, but their forbearance. They were invoked at chichi rather than the royal grave site, because many of the war charms in chichi had been theirs, and as patrimony the charms could not be used effectively against the wishes of their former owners.

There were many other minor rites associated with warfare. At Vugha as men were leaving for war a chicken was sacrificed at He Hoko, the place where the paths meet at the southern edge of the town, and the men were strengthened with protective medicines. Dream diviners (wagonezi, s. mgonezi) were employed by each chief to foretell the day of an enemy attack, to select a propitious day for taking the offensive, and sometimes to select and keep back those who will die. In December 1872 a U.M.C.A. missionary stayed at a village which held back from taking part in a war because their dream diviner had not yet arrived, even though all the neighbouring villages had gone.<sup>8</sup> If the fighting men on their way to war saw a lizard on the path, or some other bad omen, they all returned to their homes.

It may at first glance seem remarkable that in spite of the numerous rites which were performed, the Shambaa acknowledged the uncertainty of the outcome of battle. But there is, in fact, a large set of rites and magical usages, of which war rites are only one small

part, in which there is never certainty as to the result of the rites. These are the rites and usages in which two magicians or two strong leaders are opposed to one another, and are making counter-magic. In the use of rain magic, as will be shown in chapter viii, the rites are invariably effective except when a competing rain magician is making counter-rites. In cases of sorcery among ordinary people, the outcome is never certain because the sorcerer and the healer are working against one another. In sorcery and counter-sorcery, as in war magic, charms and spells proliferate, because each medicine man seeks an advantage over his opponent.

The importance of the conflict between opposing war charms is illustrated by the extreme efforts made by fighters in battle to destroy the efficacy of the personal war charms of the opponents. The personal charms were thought to be inevitably effective unless some prohibition (ng'wiko, pl. miiko) respected by the user of the charm had been violated. In the case of some charms it was thought that if the user came into contact with the flower of a banana plant, the charm would lose its efficacy. In others, the prohibited object was the ntua (Solanum campylacanthum Hochst., S. incanum L, S. obliquum Damm. Sol.). This meant that in battle some men spent part of their time throwing banana flowers and ntua fruit at one another. If one of the most prominent fighters, a fierce one of war (see below) died in battle, his body was chopped

into small pieces by the fighting men nearby, for it was believed that if the enemy could take the whole body, they could make charms which would enable them to defeat the dead man's army in each successive battle.

\* \* \*

Any offensive battle with a more serious purpose than the most casual small scale cattle or slave raid had as its purpose the capture of a chief's (or sub-chief's) town or village, at which the population of a chiefdom gathered for political purposes, and which was the visible symbol of the chief's eminence. Since the capitals were fortified villages to which the women and children fled with possessions and livestock at the sound of the war drum, great amounts of booty could be taken once a fortified position was overrun.<sup>9</sup> Once a town had been taken, the defeated chief tried to build a fortified position as quickly as possible, and successive battle would also take the form of attacks against fixed positions.

Shambaa chiefs took great care with the selection of capital sites, and with their fortification. Capitals were usually located high on the peaks of mountains, with very difficult access, although there were some cases, especially in the plains, of chiefly villages located in the middle of impenetrable thickets. Village sites could be tried and changed with experience. Kihedu, chief of Bagha in the 1880's, built a village on a forested mountain top, and lost a number

of men in his first battle because the enemy appeared without warning from the forest. He moved down to a thicket in the valley, with a clearing around it, and dug deep trenches just inside the thicket.

Keith Johnston visited Mghambo, the capital of the separate power of the sons of Mnkande, which was trying to take back the kingdom. He described the village and its fortifications as he saw them during his visit in 1879 (1879: 550-551).

All around the village, excepting the gateways, a dense jungle, which would be most difficult to penetrate, makes an efficient fortification, and outside this a second barrier is formed by felled trees and deep trenches. The gateways are in walls of posts driven into the ground so as to form a mass quite six feet thick, which reach into the jungle on each side, and each narrow gate has two doors formed of heavy single slabs of timber.

A Bethel missionary described the chief's capital at Mtii, in the northwest of Shambaai (Döring 1900a: 22).

Beneath, the mountain was cut off by an impenetrable strip of thicket and thick palisades. The gate was big enough for a cow, then followed a narrower way, and finally a gate. Right and left I saw shooting slits and a kind of simple bastion in which the palisades were set forward in a tower like manner, and ditches were set behind it.

Mtii could not have withstood a long siege (a week or more), because it had no source of water. Fortified villages built in situations where extended warfare was expected needed to have their own water supplies.

Vugha itself was protected by fortified outposts manned by

chiefs of commoners along the probable invasion routes through the mountains or up the escarpment, so that the royal capital could be attacked only when its strategic outposts had been overrun. Kimweri ye Nyumbai, the King who ruled from about 1815 to 1862, placed a commoner with a great many sons in the village of Nkoongo (or Nkolongo), at the foot of the escarpment, to the south-west of Vugha, to block the easiest invasion path and give warning of enemies. He also placed a commoner at Kighuunde, near the modern town of Soni, to the north-west of Vugha, to warn of invasions from the plains which avoided Nkoongo and took an alternative route into the mountains. Kimweri Maguvu, who ruled in the 1870's and 1880's, and who fought the splinter kingdom of the sons of Mnkande, which was a separate power throughout his reign, added more outposts. When the enemy occupied Makanya on the eastern part of Shambaai's northern edge Kimweri placed a Kilindi chief at Bagha along the valley which led up to Vugha from Makanya. When the enemy had been driven out, Kimweri Maguvu added an outpost manned by a commoner at Makanya. Kimweri Maguvu also sent a commoner to build a war village on the eastern escarpment of Shambaai facing across the Luengera Valley to the enemy's capital at Mghambo.<sup>10</sup>

Warning of attack was communicated by war drum. There was a drum in each chief's or sub-chief's capital. There were different drum beats to warn of predatory animals, of distant war danger, and of immediate war danger. In some cases warnings were shouted

from place to place while the drums sounded. When the fighting men heard the war drum beat, they took up their weapons and ran to the nearest drum. Each man would arrive waving his spear or bush knife, and shouting "Tighambieni, tighnambieni," 'Tell us what it is, tell us what it is.' The beater of the drum would either give specific details of the location of the battle, or tell the fighters the direction from which he had picked up the warning, in which case the fighters would run on to the next drum. There was a gap between northern and southern Shambaai, but warnings could be communicated for men in either region to assemble at a single place for battle. An early Bethel missionary, who was present at such warnings, estimated that the northern chiefdoms could assemble a defensive force of 3,000 men, and the southern chiefdoms could bring together 6,000 men.<sup>11</sup> Some men stayed behind in each village and each fortified spot to maintain local defences.

An army, once assembled, included ordinary fighters, the King or chief with a group of followers, who remained separate from the battle, and the wakai wa nkondo -- the fierce ones of war, including the flag carrier, the carrier of the magical staff, and other renowned fighters.

If a single chiefdom went to war, men from different parts of the territory were sent to fight side by side (except for the division of Vugha into East and West), and men with different kinds of weapons were sent to fight alongside one another -- some with bows and arrows, some with spears, others with firearms. If the entire kingdom, or

a large part of it, went to war, the men of each chiefdom remained together, under the leadership in battle of the chief's son (that is, in the terminology used here, the sub-chief) who was best known for his ability at fighting (Karasek 1923-1924: 48). Very minor chiefs sometimes led their own men. The place from which the King or chief observed the progress of his men was at some distance from the battle. Depending on the terrain and the size of the army, the chief's place could be from fifty yards to a mile behind the actual fighting.

The chief's place was called he nkii, or he ngahu. He nkii means, at the town gate. Thus, with the chief's place seen as a town gate, the entire battle was referred to, in this terminological fiction, as one between two towns, one of which had moved up to the other. He ngahu means 'at the basket,' because all captives and captured livestock were brought to 'the basket' of the chief.

The King wore his *linga* (headdress), because this was his greatest protective charm. With the King (or chief) were some of his officials, and a man with protective medicines that the chief could administer to his retreating troops before sending them back to the battle (Karasek 1923-1924: 21). The King himself carried no arms to battle, because it was he who was called Ne Mweghojwa. This is an interesting play on words. The closest literal translation would be, 'He who is awaited.' When used to describe the King in battle, it means, 'He who is guarded.' That is, the central purpose of the army was to defend their King 'at the gate.' The same

phrase is used in discussions of litigation to mean, 'He whose word is awaited,' that is, the one who ultimately judges cases.

The fierce ones of war together with the sons of chiefs led the army in battle. The flag was carried by a fierce one. The flags were usually white or red. There was considerable disagreement among my informants concerning the use of the flag (biamu, or bilamu). Some said that there were as many flags as there were chiefdoms. Others said that there were only two flags, one for each side, and that if one side showed a white flag, the other would show a red flag, so the sides could be distinguished, and men could find their own army in the confusion of battle. Others among the fierce ones of war carried magical staffs into battle, each laden with war charms and amulets.

An attacking army could stay in the field for only a very brief time -- not much more than a week, except at harvest time. There were two problems with prolonged campaigns food supply, and sanitation. An army could take with it only as much food as it could carry on the heads of its men. The men would cluster in small groups and cook what they had brought. When these supplies were finished, the army had to live off the land. A bishop of the U.M.C.A. visited the war camp of Kimweri Maguvu in 1884, just before it attacked the separate Kilindi power at Mghambo. He saw armed men returning from a raid, carrying Indian corn, and he saw soldiers taking captive women back to their own fields to gather corn for their captors (Ward 1898: 33-35). Keeping an army of a thousand or more men healthy while

camping out without latrines was another problem. One army which Kimweri Maguvu assembled to attack Mghambo was disbanded when dysentery incapacitated the majority of the men.

Given the very short period an army stayed in the field, there was a great reliance, in the offensive army, on surprise. Besiegers were often in a more difficult position than besieged, and so it was most desirable to take a town with the first attack. In most accounts I have recorded of major battles, there was first a feint by one part of the army, drawing defending forces away from the true target, and then an attack by the main force. The attack in 1868 which resulted in the burning of Vugha was typical in this respect. The first group came from the north-east, through Kighuunde. When the war drums had finished beating to announce the attack, and Vugha's defenders had gone to Kighuunde, the main body of attackers climbed the escarpment to the west of Vugha, overcame the few defenders, and burned the capital (Feierman 1970: 154).

There were two ways for a battle to end. One was for the town to be taken, and the other was nkondo kutuika -- for the war to 'crack,' or to split open. The war split or cracked when the men of one side fled in confusion. This happened as a result of any event which the fighting men found startling or suddenly distressing. If a famous fierce one of war, or the son of an important Kilindi died, the war cracked, although fighting would be continued after the death of an ordinary soldier. If the war ended in victory, the

chief's 'gate' moved forward into new territory; if it ended in defeat, the 'gate' moved back. In the confusion of warfare, the sure sign that the war had ended, in either defeat or victory, came when the 'gate' moved, when 'the basket rose up.' In a sense, then, a major battle was pictured as the conflict of two capitals, with the defenders occupying one, and the 'basket' of the attackers representing the other. One town was moveable, the other stationary. The battle ended when the moveable town returned to its permanent base, or when it occupied the stationary town of the defenders. The battle can be seen, in other words, as a representation of conflicting towns with their associated territories.

The importance of the survival of a few fierce ones of war in determining the outcome of a battle meant that a war could be decided after very few deaths, especially if they were deaths of prominent leaders. One of the wars remembered even today for its violence, a great attack by Kimweri Maguvu on the separate power at Mghambo, ended in Maguvu's retreat after his army lost fifteen men.<sup>13</sup>

If the war was victorious, with booty and captives deposited 'at the basket,' the King divided the goods after the battle, keeping a considerable portion for himself, and giving large shares to the participating chiefs. Among the commoners the King's fierce ones of war were given the largest share. Many ordinary men received only pieces of meat from slaughtered livestock to take home with them. Those who captured livestock and people were given a share of what

they had brought in. The captor of a woman was given a cow; the captor of a young man was given a bull; the captor of a number of head of livestock was given about a quarter of what he brought in. The King judged the best way to secure loyalties in giving rewards. One very prominent fierce one of war was given women captives as his wives. The son of a minor fighter attached to a minor chief told me that his father had brought in a captive, but Kimweri Maguvu gave the bull to the fighter's chief. War was one of the ways for a man to grow wealthy and build his lineage. In the 1870's and 1880's a number of fighters traveled from distant parts of Shambaai to serve the King and build their fortunes.

### III

The payment of tribute is, to an outsider but not to a Shambaa, an apparent exception to the rule that wealth was only expended in order to maintain or increase living people within a lineage. It was believed that all the wealth of the land was the possession of the chief, and ultimately of the King (or of a chief at a locus of power), and that if the entire land was not put in the hands of the chief, then he would not make rites which were adequate for the maintenance of the land's fertility, and for its defence. The Shambaa gave all the wealth of the land into the hands of the chief so that he would work for its increase as though it were his own.

This was first explained to me by a brilliant informant (a thoughtful old blind man who had grown up at Vugha), when he was explaining to me the way in which the commoners' sacrificial rite of the clinking bells worked. The person who wishes to sacrifice to his father calls in a medicine man, and invites lineage members, all of whom come in the evening. At the start of the rite, all present go out of the house in single file, circle around outside, and then re-enter, singing that the house belongs to the medicine man. The old man explained to me that the house is given to the medicine man so that he will 'build' your house as though it were his own. In the morning, the house is 'redeemed' -- bought back with a payment to the medicine man of one side of the goat sacrificed, together with the neck and the skin. While the medicine man must take possession of the house in order to perform the rite, it is essential that he not be a member of the sacrificing lineage. He must be an outsider who is given the house, just as the chief is seen as an outsider who is given the chieftom by his autochthonous subjects. In important curative rites, the medicine man must always be an outsider. When I asked a man why this was so, he replied: 'If you administer medicines yourself, who will you pay?'

The belief that a powerful person must own the wealth of the land if he is to protect it, is illustrated by an incident which occurred at Vugha in 1897, in the period of confusion after Kimweri Maguvu had died, Semboja had died, Semboja's successor at Mazinde

had died, and the Germans had hung Kimweri Maguvu's successor as King of Vugha. There was an outbreak of cattle disease at the village of Kighuunde, near Vugha. The leader of the local people went to Vugha's German missionary and explained his wishes in the following way: 'Our livestock are dying. If we are under your protection, we will keep our livestock, I would like to give you a ewe, for you to care for, and so that you will one day have a herd of your own. Then if my animals die, so will yours; if I drink milk, so will you.'<sup>14</sup>

In one sense, then, the King, or the chief at a locus of power, owned all the land. This is the meaning of the King's title ng'wenye shi -- the owner of the land. The King could not be bribed. With what will you bribe him, when everything is his? He might be influenced by the payment of a goat as homage (matulo), but this was not a bribe, for the goat was his. What would influence him in such a case was the subject's show of willingness.

In the case of the medicine man at a sacrificial rite, the possession of the house, was a polite fiction. The medicine man was required to return the house to its owner in the morning. The King's ownership of the land was not so simple. There was a general expectation that the King would limit his demands for livestock, that he would not send his agents many times to a single village to collect tribute. My old blind informant insisted that the King's ownership, too, was fiction. 'The King does not possess the land.

He is being deceived [by those who tell him the land is his.] It is not his land; it belongs to the autochthones. He is like the medicine man in the sacrifice.' At the same time, the King was like a lion, as his praise name (Simba Mwene) indicated. He descended upon any of the livestock of the kingdom at any time of his choosing. And he was the possessor of power, who was able to kill people. If the King, or a chief at a locus of power, chose to violate accepted norms, there was no immediate way to stop him, although his acts were seen as illegitimate. The unfair and oppressive collection of tribute was called kuja wantu, 'to eat people,' for once the commoners lost their wealth, their lives were in danger.

Each household of ordinary subjects paid not only wealth to the maintenance of the political establishment, but also labour, staple, and firewood. The commoners farmed the gardens of the chief, which were the main source of food for the chief and his courtiers, visitors to the capital, and fierce ones of war. The commoners also maintained the network of paths which connected each capital to its outlying areas, to other capitals, and to Vugha. The quality of the maintenance of paths depended, to a certain extent, on political conditions. Paths at Vugha which had been 1 1/2 metres wide in the relatively peaceful days of Kimweri ye Nyumbai (before 1862) became overgrown during the wars of the 1870's and 1880's.

When there was work to be done, the town crier announced in the evening that there would be a working party the following morning,

and he specified which age and sex groups would be expected to work. In the morning, the bushbuck horn (gunda, pl. magunda) was blown to announce the start of the working group. If an individual did not come to work, some members of the party were sent to his house to take a chicken as a fine (uhambuzi; to impose a fine is kuhambua). Most of the chief's work was done by the young men and women of the bachelors' houses, with the chiefs of the bachelor houses as overseers. The adult men sometimes worked for the chief. The adult women, who were heavily burdened with work at home and on their farms, almost never did. The working groups were fed at the expense of the chief, who would often work alongside his subjects in the fields. Tribute labour was not the sole support of the chief. His wives, and even the King's wives, were expected to maintain their farms, although often they had young slaves to help them.<sup>16</sup>

Food was brought to the chiefly capital either at the request of the court officials, when the chief's resources were inadequate for special periodic demands, or as a gesture of respect by the women of the chiefdom after a good harvest, since the chief was thought at least partially responsible for the excellence of the harvest. Food and firewood were the main contributions of adult women to the maintenance of the court.<sup>17</sup>

Food was brought to court in times of plenty, and service was at worst an annoyance; the onerous burden on an ordinary subject was the requirement that he pay tribute in wealth (usually livestock).

Each sub-chief collected wealth in his own territory. A chief collected tribute directly from the area under his immediate control, and through requests to the sub-chiefs in their lands. The court officials of the chiefs and sub-chiefs, and the King's representatives at Vugha were, together with the hangers-on, the collectors of tribute. They were sent out when the needs of the court required. They went armed, in case they met with resistance. In one instance of tribute collection from the semi-independent coastal areas (a difficult and dangerous kind of collection), Krapf in 1852 saw the tribute being collected, and he observed its division at the court of Kimweri ye Nyumbai. 200 pieces of cloth were brought back to Vugha, of which Kimweri took 100, the men who went to the coast received 42, the chiefs of Vugha (probably the King's representatives together with the court officials) received 33, and the Beleko (probably the King's representative for the district) 25 (1964: part 2, 281, 304). Hangers-on could go out to collect tribute locally on their own initiative, without informing their chief, in return for which they were given a share of all the wealth brought in. It was considered wise for the payer of tribute to go along with his livestock to court, and personally to present it to the chief. In this way he could be sure that his tribute reached the chief. He also made certain that the chief knew the contribution was his, so that he would not be asked for tribute again until some time had passed.

The King received tribute in both food and wealth from the commoners of the area under his direct control, and from all chiefs who were not at, or dependent on, loci of power. In other words, only a chief at a locus of power (he nguvu) and the King, who was by definition at a locus of power, collected tribute without sending any on to the holder of a higher office. Commoners, sub-chiefs, and chiefs sent homage to a superior when involved in any action which might ultimately require the superior's support. If a chief who was not at a locus of power killed a witch and seized the witch's property, he would inform the sovereign on whom he was dependent of his action, and send along a portion of the property. In a case which took place in the 1880's, a Vugha lineage lost some women to kidnapers, who sold them to coastal slave traders. When the lineage members attacked the traders and seized the women together with a considerable quantity of cloth, they gave the King a portion of the cloth because it was possible that he might become embroiled in the dispute, or that his relations with traders might be affected. In cases where a chief was not at a locus of power, but was not appointed by the King, a cow was sent to Vugha as homage at the time of a new chief's accession, to show that the new chief was indeed dependent.

The ultimate effect of the pattern of tribute payments was to give a chief who was at a locus of power greater material resources than one who was not, and to give the King the greatest resources of all. In addition to the tribute from chiefs, the King received

wealth from dependent territories which were not ruled by Kilindi chiefs, which did not send cases to Vugha or go to war at the side of the King, but which paid tribute every two or three years, and which sent homage to Vugha at the accession of a new local chief. The tribute paid by the coastal towns, as observed by Krapf, was part of a non-Kilindi tributary arrangement. In some cases, partially independent tributary in one generation became a chiefdom in the next. It is quite probable that the northern chiefdoms of Shambaai had been tributaries before they became chiefdoms (Feierman 1970: chapter iv).

Collection from tributaries was one of the ways a King increased his wealth, even at a time when many chiefs retained independent loci of power. There seem to have been a number of alien territories which found the payment of tribute preferable to facing the depredations of Vugha's army. In addition, one tusk of any elephant killed was the property of the King (or a chief at a locus of power), who paid two or three head of cattle as compensation to the hunter, to be shared, when appropriate, with the hunter's chief. The King usually purchased the second tusk. In the first half of the nineteenth century, all ivory went to Kimweri ye Nyumbai at Vugha. Later in the century, most ivory was ultimately brought (or sold) to Semboja at Mazinde, for he was the Kilindi with the best commercial contacts. Semboja, in addition, retained a corps

of elephant hunters. With respect to ivory, as so often with tribute, the property relations were a true reflection of the distribution of power.

There were additional sources of wealth, which increased the discrepancy in material resources between a Kilindi at a locus of power, and one who was not. Only a Kilindi at a locus of power could demand wealth from foreign travellers passing through Shambaai (cf. Krapf 1964: part ii, 115). Only he could carry out extensive raids against foreign territories for cattle. Any chief who was thought to have potent rain charms, and who was at a locus of power, was brought wealth by the surrounding people, even if they were not his subjects, in return for his help at bringing rain.<sup>18</sup> Chiefs at loci of power increased their wealth by hearing appeals of cases drawn from a great area, and receiving their portion of the compensation.

The wealth which was collected by each chief was used to sustain and increase his power. The more successful a Kilindi at a locus of power was at concentrating tribute in his own hands, the more likely he was to go on being successful, and to go on being independent of other Kilindi, or, in the case of the King, to extend the area of domination. The wealth of a chief was used for purchasing guns and powder (after 1840), and for supporting his many followers, including the fierce ones of war who lived at his capital. The wealth was also used for the purchase of magical charms for war and the fertility of the land, and the knowledge needed to use them.

Every chief owned some magical charms as part of his patrimony, but a chief was expected to use his 'unlimited' wealth to purchase knowledge of as many additional charms as possible, so that the capital had a concentration of the best magic of the chiefdom. In the case of unusually powerful commoner magicians of great renown, the chief paid for the medicine man to perform magical rites for the land.

A King or chief with great power drew upon the tribute of a large area, and spent most of it near his capital, rewarding his fighters, feeding his officials and hangers-on, paying his magicians, giving a share of the tribute to its collectors. This meant that ambitious men could make their fortunes at the capital. It also meant that the greater the power of the King -- the greater the number of chiefdoms from which he collected tribute -- the richer Vugha's men were likely to be. The commoners of Vugha had an interest in building the King's power, and it is clear from the disastrous reign of Shekulwavu in the 1860's, that they grew restive when the King did not dominate. The redistributive mechanism also led to the relative deprivation, under a powerful King, of the distant non-Shambaa eastern chiefdoms and semi-independent tributaries. These paid tribute to Vugha, but received little in return. They were too distant from Vugha for commoners to seek appeals, and they did not have the full protection of the Shambaa kingdom against outside attack. During the reign of Kimweri ye Nyumbai, at the

height of centralized rule, when it seems that all Shambaa subjects were delighted with Kilindi rule, there were minor rebellions and there was resistance against tribute collection in the eastern chiefdoms (Feierman 1970: 111).

#### IV

The administration of the Shambaa kingdom was of a kind familiar to social anthropologists. The commoner administrative staff of each Kilindi office holder was relatively unspecialized. In each case, a single set of officials heard cases, collected tribute, and went to war. There was a small group of specialized medicine men and fierce ones of war. Chiefs at every level of the pyramid could, under certain circumstances, exercise all the powers of the King at the highest level. This situation is not uncommon in African states.

A problem is raised concerning the degree to which the Shambaa kingdom was centralized, in comparison with other African kingdoms. Southall (1956), with Apter following him (1961: 85-89), had made a distinction between segmentary or pyramidal states on the one hand, and hierarchical states on the other. In pyramidal states, territorial sovereignty is recognized but limited and relative, with authority most absolute near the centre and increasingly restricted toward the periphery. There is a specialized administrative staff at the centre, which is repeated on a reduced scale at all the peripheral foci of administration. Similar powers are repeated at

each level. The more peripheral a subordinate authority is, the more chance it has to change its allegiance from one pyramid to another. In hierarchical states, on the other hand, similar powers are not articulated through the various levels of the system, but inhere at the top. Vansina (1962) carries the argument further. He points out that virtually all African states are segmentary, in Southall's sense, but that it is possible within that class of states to distinguish the degree to which royal authority is delegated to the provincial rulers. Lloyd (1965: 81) attempts to find more precise criteria for defining the relative centralization of African states. Richards (1961: 144) describes some of the mechanisms which exist in African states where kings were able to resist the separatist tendencies of their princedoms.

There is a grave difficulty with all of these approaches to the study of the relative centralization of African states. The difficulty is mentioned, but not examined in detail, by Vansina (1962: 330):

Our formulation of the common features in African kingdoms has been very formal and rigid; but the actual functioning of the political institutions has not generally been sufficiently described to deepen the comparison. We are, however, conscious of this limitation and appreciate that a discussion in terms of constitutions alone remains unsatisfactory. An instance may stress the point. In theory all the Kuba chiefdoms have the same links with the king and the central chiefdom. In practice the hold of the king over them varied greatly from one chiefdom to another and from one moment to another. It is certain that in order to analyse the political system it becomes necessary to recognize this and to investigate the factors which bring about such

effects. The same remark holds good for the two other kingdoms with which we have been familiar: Ruanda and Burundi. Yet one can find no more than a hint in the literature which would point to this discrepancy between theoretical constitutions and the actual patterns of government.

This is an acknowledgement of a remarkable state of the literature about African kingdoms. An essential characteristic of the relationship between king and chiefs in most pre-colonial African kingdoms was its variability from one point in time to another. This is clear for the Shambaa, the Kuba, Ruanda, Burundi. Evans-Pritchard has described this for the Zande (1971), and Gluckman for the Bemba (1963). It is also clear from the abundant historical literature which has appeared in recent years on Buganda and Sahanti.

The nature of the difficulty will become clearer if we examine the Shambaa case with reference to the single most meaningful criterion of centralization. Southall argues that the criterion by which it is possible to separate unitary or hierarchical states from segmentary or pyramidal ones is Weber's concept of legitimacy. Among the Alur, Southall says (1956: 251-252), the central authority at the top of the pyramid is only able to enforce its will throughout the area nominally subordinate to it if it is able to call upon the self-interest of segments in one quarter of the realm to crush recalcitrance in another. Southall then quotes Weber, who wrote that an order which is adhered to from motives of pure expediency is generally much less stable than one upheld on a purely customary basis, with associated

habitual behaviour. The latter type of order is much less stable in turn than an order which is considered binding, or, in other words, of 'legitimacy.'

In the Shambaa case, the order, or normative system (Weber 1947: 124n), with regard to which action between King and chiefs was oriented, was at times considered binding, and at other times adhered to from motives of pure expediency. We can find examples of pure expediency during the reign of Kimweri Maguvu. The weaker chiefs of southern Shambaa supported Kimweri Maguvu in his wars because he would attack them if they did not (see p.203 ). In one major battle, the chief of Ubi (one of the stronger chiefs) came to Maguvu's aid only after Maguvu had paid three cows in advance.

During the reign of Kimweri ye Nyumbai, on the other hand (described on pp.172ff ), all Kilindi chiefs sent tribute and difficult cases to the King. The King was able to appoint chiefs, and to remove them. It is clear from all accounts of the period that the chiefs did not question the binding necessity to support the King in all his endeavours. The basis of Kimweri ye Nyumbai's legitimacy was not his position of King over chiefs, but his status as father in a territory where virtually all chiefs were his sons. Kimweri ye Nyumbai was forced to send armies to collect tribute only to that area of the kingdom in which Kilindi were not chiefs. It is instructive to remember the response of the chiefs to Kimweri ye Nyumbai's decision on the succession after his own death. Kimweri called all his

important sons together to announce that since his son of the great house had died, the next King would be his own grandson Shekulwavu. Mshuza of Ubii, the oldest of Kimweri ye Nyumbai's children, was asked to swear that neither he nor his descendants would ever take Vugha, and he took the oath. All of Kimweri ye Nyumbai's children accepted their father's decision during his lifetime. It was only after his death that they did not feel a binding necessity to support the King.

It is possible to argue that even during the reign of Kimweri ye Nyumbai, the chiefs were motivated by self interest. Any attack on the King by one son would have been seen by all others as an attempt by one brother to establish preeminence over the others. But this is not a valid argument. The potential use of force is never totally absent from the exercise of legitimate authority. We can say that Kimweri ye Nyumbai's rule was seen by the chiefs as legitimate because force was virtually never used in imposing the King's will. The symbolic efficacy of the position of King-father was never challenged, to my knowledge. In this situation, kinship values were far from antagonistic to hierarchical state values. They were the basis of hierarchy, for as long as it persisted.

We must conclude, then, that the Shambaa state was both hierarchical and segmentary, both unitary and pyramidal, or, in other words, that for the Shambaa kingdom it is not profitable to ask whether the state was more or less centralized within a certain range. It was both.

Complicated as the Shambaa kingdom looks, when one attempts to apply external criteria of centralization, the Shambaa themselves communicate an understanding of their political system to one another with the utmost simplicity, and in terms which account for the variability of the relationship between King and chiefs. Two distinctions account for all the relationships within the borders of the kingdom. First, there were chiefs who were sons of the King, and others who were not. Sons of the King always regarded their father's authority as binding, since they derived their own legitimacy from him. A King could remove his sons from their chiefdoms, appoint them to other chiefdoms, replace them with other men. A King did not have the same power of appointment in chiefdoms which were held by brothers or agnates other than sons. Any chief except a son could have been expected to resist removal.

In chiefdoms which were not governed by sons there was a second distinction between chiefdoms which were under the power of the King, and those which were he nguvu -- at an independent locus of power. Political theorists have notorious difficulties in attempting to define power operationally, but the Shambaa define it in practice with clarity and precision. A chief had independent power if he was able to enforce judgement in cases. These could then not be appealed to any higher authority. He had independent power if he did not pay tribute to the King, and if he could refuse to send his men along with the King's army.

It was never assumed that chiefs at the periphery of the kingdom were necessarily at independent loci of power, or that those at the centre were under royal domination. It was necessary, at any given time, to know where the loci of power were. The only certainty, in this respect, was that a son of the King could never be at an independent locus of power.

The Shambaa terminology of office was well suited to the variability of centralization. Every Kilindi office holder, from the holder of a small section of a chiefdom, to the King himself, was called zumbe -- 'chief.' Changes in the distribution of power could be accommodated without any changes of title. One simply specified that a particular zumbe was at a locus of power, or that another sent tribute to Vugha. The King, however, had an additional title: Simba mwene, 'the lion' which preyed upon the entire land, which ate tribute from the whole kingdom. This title, however, expressed the hopeful expectation of the King's men, rather than an invariably applicable description.

## FOOTNOTES

<sup>1</sup>Many of the terms associated with court cases have changed since the beginning of the colonial period, because the Shambaa adopted the terminology of the colonial courts. Instead of -fyalima one now hears the Swahili word -shtaki for the making of a complaint. A judge is called a hakimu, rather than a mulamuzi. A witness is now called an mshahidi, instead of a mwona. Very old men remember the former terms, and their statements are confirmed by the early Shambaa dictionaries of Steere (1867) and LangHeinrich (1921). Further evidence on Shambaa law is given by Wohlrab (1918), LangHeinrich (1903), Storch (1895), in addition to scattered references to cases in mission diaries. Most of the account given here is derived from the statements of twelve aged Shambaa informants, consulted individually and not as a group; some of them were consulted a number of times. Their testimony is supplemented by passing references to court cases in family traditions, by the written materials listed above, and by observations of moots and court cases between 1966 and 1968.

<sup>2</sup>The proverb is given by Johanssen and Döring 1914-1915: 221, but the translation is my own because Johanssen and Döring omitted the causal connection between saving and killing.

<sup>3</sup>In Storch's account, the share of the chief and court officials is somewhat higher than that given here, as reported in oral accounts.

<sup>4</sup>Wohlrab wrote that a slave could not use the wealth acquired through farming to redeem himself (1918: 169), but the other written sources and all the statements of my informants disagree with this. In addition to those works cited at the beginning of the section on litigation as sources for the entire section, there are a number of works which refer specifically to slavery, and there are additional oral accounts. The most valuable of the written accounts is located in the archives of the Bethel Mission, in the diaries of the Neu Bethel mission station (17 February 1894, 26 February 1894, 11 December 1895, and 25 January 1899). A number of conversations on slavery with court officials and local residents are recorded in these entries. There is further information, recorded by a Neu Bethel missionary, in Nachrichten aus der Ostafrikanischen Mission, November 1893, p. 184. There is, in addition, the account of Karasek (1918-1922: 81-82).

<sup>5</sup>The account of warfare presented here is based on three sets of information. First, I attempted, in discussions with a number of old men, many of whom were sons of war leaders, to define terms, and to collect descriptions of the organization of a fighting force, and of the rites associated with warfare. Secondly, there were a great many oral historical narratives which I collected, in which important wars are described in great detail. Thirdly, there are written descriptions of fortifications, of preparations for war, and of actual battles, as observed by missionaries before the final conquest of the Shambaa kingdom. U.M.C.A. missionaries were present in East Usambara and Bondei for twenty years of intermittent warfare. Bethel missionaries were present in Shambaa for several years before the end of warfare. Citations will be given at appropriate points in the text, and all sources are listed in the bibliography. The organization of warfare seems to have changed quite rapidly in the second half of the nineteenth century, with the introduction of firearms and the growing importance of alliances with coastal and plains peoples for both trade and warfare. The account given here is intended as a description of warfare between 1870 and 1895, and would probably be incorrect in many details for earlier periods.

<sup>6</sup>The written account of this rite is F. Riese, "Die Opfer der Schambala," manuscript, n.d., at the Bethel Mission archives. This account is paraphrased by K. Wohlrab 1929: 29-30.

<sup>7</sup>According to Riese, there were two groups of grown men.

<sup>8</sup>Universities' Mission to Central Africa, Bluebook, 1873, p. 18.

<sup>9</sup>The oral accounts are supported by a description by Bethel missionaries of a war alarm at Mlalo in October of 1891. As soon as the drums were beaten, women fled to the town of Mlalo with livestock and baskets of goods. Nachrichten aus der ostafrikansichen Mission, January 1892, pp. 23-24.

<sup>10</sup>In each case, the founding of an outpost was described to me by a patrilineal descendant of the man who founded it.

<sup>11</sup>LangHeinrich 1913: 7. The drums are described in oral accounts, and in Nachrichten aus der ostafrikansichen Mission, November 1891, p. 173, and the Bethel Mission station diaries for Vuga, March 2, 1897.

<sup>12</sup>For a documented description of a battle see Tanzania National Archives, Church of the Province of East Africa, Magila Logbook, Feb. 27, 1888.

<sup>13</sup>Central Africa, March 1885, p. 36.

<sup>14</sup>Bethel Mission, Tagebuch Wuga, 4 June 1897.

<sup>15</sup>Bethel Mission, Tagebuch Wuga, 22 June 1896.

<sup>16</sup>The account of tribute labour is based on oral accounts, and on descriptions by the Bethel missionaries, in both station diaries and the monthly mission publication. Tagebuch Neu Bethel, 26 February 1894, 23 November 1894. Tagebuch Hohenfriedeberg, 14 December 1895. Nachrichten aus der ostafrikanischen Mission, November 1891, p. 173.

<sup>17</sup>Krapf wrote that 1/10 of the grain crop was paid as tribute (1964: part 2, 117), but this was not supported by any oral information. Krapf himself did not witness the collection of tribute in grain, and his statement is inherently improbable, for the collection of tribute was informal and intermittent. There was never any careful attempt to measure the wealth of the land or the size of the crop, and there could not have been, given the size and training of the King's administrative staff, and the staffs of the chiefs.

<sup>18</sup>An instance of this is described by Bishop Charles Alan Smythies in Central Africa, 2 June 1884, p. 101.

## CHAPTER EIGHT

### KUZIFYA SHI AND KUBANA SHI

In the chapter on the royal capital, in that on succession rites, and in scattered places throughout this work, I have examined a number of powerful symbols which express the ambiguity and ambivalence of kingship. In the portion of the accession rite called the dramatization of forces, the King was greeted as a murderous buffalo, and at the same time was told that he was expected to bring rain and food to the people of Shambaa. The King was like a dangerous person who travelled at night, but he was also like the moon, travelling in a rhythmed, deathless, eternally regenerative manner. At Vugha, the King was likened to an mvumo, the liana which killed its host tree, but which also cast the cool shade in which cases were heard, and therefore recalled the peaceful agreement he encouraged among his subjects.

I have been very conservative in my approach to the study of symbols; I have tried to find the context of each in the symbolic configuration being studied, and in Shambaa thought, but the explication has always remained very close to the concrete level. What is absent from the study of symbolic relations, as it has been presented to this point, is any kind of indigenous discursive statement of political ideals and principles, except for exegesis on the symbolic relations themselves. The full exploration of the

symbols of kingship cannot give us a coherent sense of the way in which Shambaa pictured choices between alternative political actions, or the way in which leaders legitimized actions. Most of the symbols were (and are), as we have seen, ambivalent. The King brought fertility, and he threatened poverty or death. But nothing in the symbols themselves showed men how to achieve the former rather than the latter. Turner (1967: 28), Leach (1958), Beidelman (1966), and others have shown that ritual symbols derive their efficacy at stirring emotions from their rootedness in the processes of the body. Milk, blood, and women's breasts as significant appeal to the lowest common denominator of human feeling. The same is true for symbols of Shambaa kingship, but with one important difference: while many of the symbols of politics were rooted in experiences vital to the individual's survival, they were seen as experiences of action in the political rather than the purely personal realm, either because they symbolized the individual's experience of contact with those in power (as in impoverishment through the payment of tribute), or because they represented experiences shared by all the people of a territorial unit, as in famine or warfare. Thus the symbols of the King as a lion taking cattle, a buffalo or an mvumo killing men, were rooted in the individual's existential experience of politics. The royal burial enclosure, when seen as a rain shrine with sprouting maeze, referred to an individual's relief at the end of a famine; this experience is one which was

shared by all people of the land as a community, and as individuals. The burial enclosure seen as the place where potentially dangerous royal ancestors were found referred to the individual's, and the land's, experience of famine, or of defencelessness in warfare.

The symbols found in the succession, or in the shape of the capital, did not instruct the Shambaa in how to achieve plenty rather than famine, or life rather than death, even when the symbols were understood with a full range of relations. All the observers of the rites, all the residents of the capital, indeed all responsible Shambaa were aware of the political conditions necessary for plenty. This knowledge was transmitted in two ways: through discourse on the nature of politics, and through popular explanation of the causes of natural or political events which affected an entire land. Of these two forms, the latter was much more certain to lead to repeated instruction of the young and the ignorant in the political ideals of the kingdom. In fact, it is possible that I would not have learned Shambaa explanations of the relationship between politics and plenty had I not been present during a minor famine.

There are two concepts which are crucial to any statement, or any understanding, of the political ideals of the Shambaa: kubana shi is to break or harm the land; kuzifya shi is to repair the land. The way in which they are used is best illustrated by a conversation which I had with my assistant. This conversation occurred at a time when I understood the concepts, and merely wanted to confirm

my understanding. My assistant's statements were not in any way idiosyncratic. They were similar to statements I heard given by a great many Shambaa.

Ethnographer: What is 'to repair the land'?

Assistant: It is when the food plants flourish.

Ethnographer: How can the land be broken?

Assistant: When people argue and fight with one another, the land is broken. When the sun beats down [and there is no rain] people fight. Each one says, 'I am the only important one.'

Ethnographer: You and I are ordinary people. If we argue, does that break the land?

Assistant: The land is not broken.

Ethnographer: If a Kilindi mediates between us, and settles our disputes, is that called repairing the land?

Assistant: You cannot say that he has repaired the land.

Ethnographer: If the King oppresses the people of the land, what can they do?

Assistant: They can all go to him together, and say, 'If we all die, will you live here alone?' He will admit his mistakes. The people of the land are not afraid to speak in this way because there are many of them.

Ethnographer: What if he refuses?

Assistant: They would then go to join another Kilindi. 'Let us fight to the death. If we all die, then it is finished.'

This conversation is typical of discussion on repairing and breaking the land. It is elliptical. Much is left out of what would be needed for a complete explanation because it is difficult for a Shambaa to imagine what it is like not to know these concepts.

The conversation was sustained only in question and answer style, and only because I knew what the concepts meant. In fact, I seem to have been drawn in to the elliptical mode of thought. Once I confirmed that ordinary people could not break the land, I did not go on to ask about the most obvious point, the way in which political leaders do break the land.

Action which destroys the land is usually described as nguvu kwa nguvu, 'force against force,' or 'power against power.' This conflict is seen as occurring between members of the Kilindi lineage, or at least between important rain magicians. It was expected that the King, or a chief, would try to bring rain at the correct time for his land. Drought occurred when a competing rain magician made counter-spells to 'hold' the rain (kutoza fua). People usually say that envy (uwizu) was the driving force of the counter-magician. The chief was given the wealth of the land so that he would make effective magic for it. His competitor would try to take away the land by showing the subjects that they could not survive if they continued to support their chief, and by showing the chief that he was an inferior magician, lacking in power. Once during my stay in Shambaai, when the time for the rains had passed and rain had not yet fallen, I stood with a friend watching the dark clouds move quickly across the sky. 'You see,' he said, 'there is an envious counter-magician holding back the rain. When you see the heavy

clouds moving like this and no rain falls you know that a medicine man is at work.'

Kuzifya shi, 'to repair the land,' is used to describe any action for increasing the fertility of the land. The opposition between breaking and repairing seems to imply that the land in its natural state, undisturbed by rain magicians, would always be fertile. But I have never heard Shambaa speculate in this way, possibly because it is very difficult for them to imagine a world without rain magicians. (There are, of course, a number of Shambaa with higher education whose view of the fertility of the land is much the same as that of educated men anywhere.)

It is possible to repair the land when there is a concentration of magical charms, and magical power, at the court of the King or chief. The concentration of powerful charms at the centre of Vugha, and the belief in the danger which existed at the heart of the capital, thus connoted that the possessor of Vugha was capable of repairing the land.

The term for a King's domination of his chiefs and of his competitors, so that he can repair the land, which then remains fertile, is kuzuiya shi, to prevent harm, or suppress conflict in the land. People also say of a King who dominated the land and brought fertility, azafunika shi, isheandue, 'he covered over the land, so that no one was willing to initiate [competitive] action.' Peace, then, is seen as a result of strength. When the King had

real authority, he was not challenged, and he was never put in a position where he would need to use force. Violence occurred in situations of competition, or 'force against force' (nguvu kwa nguvu), in which case the fertility of the land was destroyed. The Shambaa understanding of power is, then, very similar to the Parsonian understanding (1963). According to Parsons, there is always a presumption that negative sanctions will be used in the enforcement of binding decisions, but the more those sanctions are actually used, the less effective power is at securing compliance with a wide range of obligations. The King was most effective at securing compliance when the land 'was covered over,' and 'did not initiate actions,' for then he did not need to use sanctions.

This notion, that the greatest power is not tested, and is not brought into active use through force, is expressed also in Shambaa views of the contrast between young and old medicine men. I knew one very old man who took the epigrammatic name, Mzitu Mkuu, 'the great forest,' or 'the ancient forest.' When greeted, he would answer Ugona mali, 'Terrible things sleep there.' He explained that when young men learn their first powerful magical charms and usages they immediately test them out and kill one another. But an old man knows terrible things, far beyond the knowledge of the young, yet his charms remain unused and untested, like the awful creatures in the middle of a great forest. Ubwanga, 'young man-ness,' and

kibwanga, 'in the manner of a young man,' connote violence, strife, competition.

The King's power was ambivalent. It was the power to maintain the fertility of the land, but it was also the power to bring famine and death. When the King's authority was unchallenged, he brought life. When it was challenged, there was death in the land. The King's unchallenged authority enabled him to collect dangerous medicines and witches at Vugha, without harmful effects for the people of the town, or for the people of Shambaai. One man explained Vugha's character in the following way, when I said to him that the capital must have been a horrible place: 'It was not a horrible place. It was a place where poor unfortunates (wakiwa) were saved. The reason I say Vugha was not an evil place, is that once a person who had done evil things went to Vugha, he stopped. . . . If you come to Vugha and you do evil things, you will be killed because of your own evil. The Simba Mwene was able to save people because he resembled a rock. He could not be ensorcelled.'

When the King 'covered over' the land, so that no one challenged his authority, Shambaai experienced a feminine farming season (kiimo cha fyee), characterized by bountiful crops. When the King's authority was challenged, and there was 'force against force,' Shambaai experienced a masculine farming season (kiimo cha ngoshi), that is, famine. An oyster-nut plant which does not bear fruit (imba, pl. maimba; these are filled with nuts), is called a male

plant. The plants which do bear fruit are female. If maize plants grow without bearing ears, they are called masculine. Those which do bear are feminine. One young man explained the relationship between the masculine and feminine farming seasons to me in the following way:

The sun is the eye of the world. We of the world can see because of the sun. At night you cannot see, but in the daytime you can see. The world is people [i.e. social interaction]. The sun shines every day, forever and ever. It may be covered over for a day by clouds, but it is still there, up high. We use the word 'suns' (mazuwa) to mean days (mishi), because the sun shines every day. But rain has its proper times, like the moon. If you hear someone talk about a masculine farming season, it is when the sun shines altogether too much for the rain has its months. A masculine farming season is force against force, when those people battle against one another, and hold the rain. But the feminine farming season is a fertile one.

The same man explained to me at a different time that a man resembles the sun, because he is fertile every day. A woman resembles the moon, because her fertility is periodic. In Shambaa terminology, a woman's menstrual cycle is her 'moon.' She is thought to be fertile immediately after menstruation, by analogy with farming. "After the rains," explained one informant, 'you sow your seed.' Semen is called mbeyu, the word for seed. In this way, the symbols which refer to the fertility of the land are also rooted secondarily in the processes of the body. There is a further relationship between the moon and rain: it is said that after the moon dies, and is no longer visible,

'the rain washes off the moon' (fua yachunta ng'wezi) so that it can be seen again.

In addition to the opposition between the masculinity of the sun's daily movement, and the femininity of the moon's lengthened periodicity, there is an opposition between the daily regular repeated movement of women, and the random irregular movement of men. In farm work, the man is expected to do heavy clearing, and other sorts of work which recur at irregular intervals, and he considers long term plans for land use. It is the woman who goes to the garden each day for the garden's continuous maintenance. She is expected to go to her garden in the morning as the sun is moving higher in the sky, and to return to her cooking in the afternoon as the sun is declining. It is in this sense that the sun is the source of social interaction, for each person goes to perform his (or her) daily tasks as the sun goes up, and turns away from his fellows, going home, when the sun is declining. When people meet in the morning on their way from home they say kuzacha, 'the sun is rising,' meaning, 'I am going to do my daily tasks.' On their way home in the afternoon they say kuzashwa, 'the sun is declining,' meaning, 'I am returning to my home.' In addition to their farm work, men are concerned with unusual irregular problems, with the illness of a dependent, with a criminal act in the lineage, with the need for initiative in increasing wealth for the patrimony of sons, with finding food in famine. One man explained, 'The man

is concerned with difficulties. He has many concerns. The woman does the same thing every day. She goes to the river to get water, she cooks. The man can go [two hundred miles] from here to Moshi because of his worries. The man has something new to do every day. The woman only cooks. She can say, "I have nothing to cook," or "I have no relish," but the man must decide what to do.' Of the King, who is the most supremely masculine of all Shambaa, and who is concerned with the irregular affairs of the entire kingdom, it is said that he wanders at night inquiring into unusual activity, and that because he is dominant, he is alone, like a witch.

In one of the contexts discussed the sun is treated as masculine and associated with the irregular activities of men who fight each other. In another context, the sun regulates the daily activities of women, and the King wanders at night. Perhaps both sets of oppositions have been put too simply. In the burial it is said that the man is regulated by the rising sun, for he goes to hunt in the morning. Hunting, however, is irregular and unpredictable. The hunter sometimes returns with more than his household can consume, and sometimes returns with nothing. The woman always returns from the garden with enough to cook, except in famine, in which case the search for food becomes the man's work. Professor Jan Vansina has suggested to me that perhaps the Shambaa observed the irregular association between the monthly calendar and the calendar of rains, and that the imperfect periodicity of the moon

was seen as analogous to the imperfect periodicity of the rains. It is a fascinating conjecture, but I have not heard indigenous statements to demonstrate its truth.

The opposition between the feminine fertile periodicity of the moon and the masculine continuous destructiveness of the sun is, then, analogous to the opposition between regular daily feminine work, and the irregular masculine concern with hunting and lineage affairs. The two pairs are related also to two modes of political action. When referred to in terms of the fertility of the land, these modes are labelled repairing and destroying the land. This pair is related to the others by analogy, and because the characteristics of the moon and sun are seen as the defining qualities of repairing and destroying the land.

The analogical comparison can be carried further, this time in directions not explicitly discussed by Shambaa informants. It has been shown (chapter iv) that in the rites of burial and accession, the King was said to die like the moon. He was covered over only to reappear. The regularity of the moon's reappearance as expressed in the rites, in which all evidence of political competition was suppressed, was contrasted with the unpredictable quality of the events described in the historical traditions. In these, a full description is given of competition between political leaders, and no mention is made of the rhythmized repetition of life and death as expressed in the rites. Similarly, the regular alternation of

generation names in the royal lineage imposes a rhythmmed order on the passage of time, but when one wishes to describe the special irregular political acts of an individual King, one refers to him by his personal idiosyncratic name. Shekulwavu invariably follows Shebughe, but there was only one Kimweri ye Nyumbai, 'Kimweri stay-at home,' who succeeded the unique Kinyashi Muanga Ike, 'Kinyashi who walks alone.' If any King dominated the land perfectly so that no competitor initiated political action, the land would have been fertile, and there would have been no special political acts of his to remember in the traditions, only the rhythmmed succession of the seasons, and of life and death. Nguvu kwa nguvu, 'force against force,' therefore, was characterized not only by conflict and famine, but by the irregular and unpredictable occurrence of events appropriate to masculine activity. The repair of the land, when the King 'covered it over,' and no one initiated political competition, was characterized not only by peace and fertility, and the predictability of events, but also by the regular periodic fertility appropriate to feminine activity. The central rhythm of Shambaa political life was, of course, the alternation between the repair and breaking of the land.

In the conceptions just presented, the King was seen as striving to achieve the feminine periodicity of the rains, and the femininity of a rich harvest. At the same time, the King was seen as completely masculine. Any suggestion of mine that on the basis

of the conceptions of fertility one would think the King had a feminine element invariably met with shocked disbelief from the Shambaa with whom I discussed kingship. In the end they convinced me that there was no paradox. A feminine farming season, they explained, came about when the King made all the other rain magicians into women. Male connotes powerful, superior, as opposed to female which is weak, inferior. To say that the King made rain magicians into women means that he showed his superiority, and the weakness of all his potential opponents. A feminine farming season came about when, in Shambaa words, 'there was only one man in the land.' When there was one dominant rain magician, one man and all women, then there was unified planning for any of the accidental occurrences which might befall the land. Just as in a household with one man and several women the man planned for irregular occurrences and the women did their daily tasks, in a land with only one man the people of the land would go about their daily tasks, leaving the larger problems in the hands of the King or chief.

The terms kuzifya shi and kubana shi refer to the condition of the land, but they do not specify which land. The kingdom as a whole was a single land, and each chiefdom was a land. When a Shambaa says shi izabanika, 'the land has been broken,' he may mean that the entire kingdom is experiencing famine, or that only a single chiefdom is affected. The terms indicating the condition of the land are used as explanations of what we would call natural

events. In Shambaai, with its varied topology and climate, famine can strike a single chiefdom or the entire kingdom, and the explanation is varied according to the event.

If there was famine within only a single chiefdom, there were three possible explanations for the occurrence. First, it was thought possible that a rival to the chief within the land, or in a neighbouring land, was withholding the rain in order to overthrow the chief. Second, if the chief had been resisting Vugha's domination, it was possible that the King was withholding the rain in order to punish him, with the intention of either securing his submission, or breaking the ties of allegiance between chief and commoners so that the chief could be removed. The third possible explanation appears to have been used in cases where the chief was in such a strong position that either of the other two seemed unlikely. This was that the chief was angry with his subjects, or that he wanted to increase their dependence on him, and to increase the amount of tribute he collected. Subjects tended to pay more tribute in time of famine in order to move the chief to make rain, and to show that it was not they who were contesting the chief's paramountcy.

At times when the King was truly dominant, it was thought that the entire kingdom enjoyed the benefits of a repaired land. When Kimweri ye Nyumbai was King, and all of the chiefs his sons, the important rain charms of any chief had been received as

patrimony from the King. It was impossible for the chiefs to challenge the King, and there was little reason for the King to punish his sons by making famines in their lands.

It has been shown in the preceding chapter that it was possible to describe the distribution of power within the kingdom at a given time by specifying the relationship between any chief and the King in terms of descent, and by specifying which chiefs were at loci of power. The subtle variability of the distribution of power is seen when the whole kingdom is perceived at once, as in an aerial view. When seen from the point of view of an individual subject, concerned with his own well being, living in a particular chiefdom at a particular time, the political conditions with which he was in contact could be reduced to the two described here: the land was either broken or in repair.

It was thought that when the King was unrivalled in the whole of the kingdom, the people of Shambaai enjoyed not only plentiful harvests, but also relative peace, justice, and a low level of tribute demands. There were obvious reasons for a decrease in the frequency of warfare in times when the King and chiefs were not competing. Wars were most violent and protracted when there was a 'separate power,' a splinter kingdom competing with the King of Vugha for control of Shambaai. When there was no 'separate power' it was considered improper for the King and competing chiefs to make war against one another, for Shambaa to fight Shambaa. But competing

Kilindi frequently invited foreign cattle raiders, Taita or Maasai, to attack the capitals of their enemies. In times when there was no intense competition, when chiefs did not provide foreigners with Shambaa guides, with detailed plans of battle, and with co-operation in silencing warning drums, it was much more difficult for the outsiders to make successful attacks against the mountain strongholds.

The important point in this context is not that warfare was less frequent when chiefs and King did not compete, although this seems indeed to have been the case, but that Shambaa believed peace within the kingdom to be<sup>a</sup> consequence of Vugha's domination.

One old courtier at Gare explained that a period of peace came to his chiefdom as a result of unchallenged rule at Vugha: 'When conditions at Vugha were good, where could war possibly come from? After all, the great ruler was at Vugha. When there was war at Vugha, all the capitals experienced warfare. . . . The rule then was one of pleasing speech. No one spoke of war. It was a rule in which the land was covered over.'

The conditions which resulted in the King's dominance as a rain magician, led to his dominance as a war leader. It was unlikely that a Kilindi would have powerful rain charms and weak war charms. In addition, rain charms could be used for purposes of warfare. Shambaa believe that the defenders of Vugha drove back an attacking army in a war which took place in 1883 or 1884 (the War of Mbaruk)

by sending a terrible storm when the attackers had almost broken through the lines of the defending army (Feierman 1970: 192). It was thought possible for a King to punish his enemies without sending an army, by withholding rain.

The quality of justice was also thought to improve for the ordinary countryman when the King covered over the land, and there was no competitive political action among Kilindi. It has been shown in the preceding chapter that when there were no independent loci of power within the kingdom, commoners were able to appeal the results of litigation to the court of the King. When the King was their chief's father they were also able to complain of the chief's abuses of his power; in cases of extreme violations, the land was taken away from a bad chief (see chapter iv ).

When tribute flowed to Vugha from the entire kingdom, there was great wealth at the centre of the kingdom without burdensome levels of collection at any one locality. Under these circumstances, the King had the greatest concentration of wealth with which to purchase new exotic rain and war charms, thereby increasing both the centralization of power and the fertility of the land.

None of the advantages of centralization was seen as a benefit by those who lived at the extreme edges of the kingdom, especially in the east, at Bondei and the coastal zone. The climatic difference between Shambaai and the lowlying areas to the east is great enough that it must have been difficult to imagine that the

King's rain fell on these regions. In the period of the greatest centralization, the reign of Kimweri ye Nyumbai, the King was unable to protect the eastern edges of the kingdom against raids from the south. Kimweri's punishment, for chiefs who abused their power in Shambaai, was to send them to an area where the subjects were not Shambaa, usually in the east. The eastern provinces were too distant, and there was too little sympathy for their people at Vugha, for easterners to appeal cases at the capital. Tribute paid in the east for the royal court was consumed by the people of Vugha. It is for these reasons that there were rebellions in the eastern provinces during the reign of Kimweri ye Nyumbai, which the people of Shambaai still remember as the golden age of Kilindi rule (Feierman 1970: 111 et passim). It is also for these reasons that the Bondei fought to throw off Kilindi rule altogether upon the outbreak of war among the Kilindi after Kimweri ye Nyumbai's death. My own field research was done entirely among the people of Shambaai, who had the most to gain from hierarchy in the relations between King and chiefs. I have no idea whether Bondei describe the value of covering over the land, as opposed to force against force, in the same way.

There is a very difficult problem, which remains to be faced, of demonstrating the historicity of the ideas which have been outlined here. The symbols of kingship discussed in the chapter on Vugha, and in that on rites of succession, were concrete, and

conquest (see below), and the concepts must have been established before the separation took place.

According to the private oral traditions of the Hea clan, the kiza, the pot which was kept at the royal burial enclosure, and which was used in magical rites for the fertility of the land, had belonged to the Hea before their ritual leader had been killed by the first King, Mbegha (see pp. 53-55 ). Mbegha took the kiza as part of an attempt to concentrate rain charms at the court of the King. This act which occurred shortly after the founding of the kingdom is fully congruent with explanations given by present day informants of the way in which the concentration of rain charms was essential for the success of the rain magician. There are a number of tales about famous magicians who came to the land with esoteric charms, which were purchased by the King; in each case the magician was killed by the King so that knowledge of the charm would not spread. The Hea version of the events is supported by the independent evidence of the distribution of kiza rain shrines. A number of variants of the kiza (described above, p. 288) are spread around Shambaai, in the hands of commoner lineages. No one shrine is quite like the kiza at Vugha, yet it is clear from the wide distribution, from the existence of variants, from the fact that other rain charms have not spread from Kilindi to commoners, that the kiza existed in Shambaai before the arrival of the Kilindi, and before the concentration of rain charms.

A further bit of evidence is a song which, according to my informants, refers to Mboza Mamwinu, the famous Kilindi woman magician who fought against the succession of Kinyashi Muanga Ike in the late eighteenth century. I have never heard of any other Kilindi figure or rain magician named Mboza.

Iwe Mboza tinke tije,	You, Mboza, give us food that we may eat,
Tiighae togolo.	So that we may praise you.
Koo ndima ee.	Take our service.
Koo milimo ee.	Take the work of our hands.
Koo ndima ee.	Take our service.
Koo milimo ee.	Take the work of our hands.
Oeeeeee,	Oeeeeee,

Mboza utendie zeze?	What awful things did you do, Mboza?
Miya ishwi tinke tije, ...	But as for us, give us food that we may eat, ...

There is little doubt that the song itself existed at the time of Mboza, in the eighteenth century. It can therefore be taken as a document demonstrating the existence of the ideas expressed at that time.

U.M.C.A. missionaries observed and described the politics of rain magic from the 1860's on, and there was no indication that they were describing ideas or practices which were novel. One missionary observed a Zigula war party in 1868 on its way to attack a Shambaa village. 'The reason of all this was as follows: -- The people on the plains had no rain; those on the hills had plenty; therefore the highlanders had used medicine against the lowlanders, and must be punished.'<sup>1</sup> In 1884, when the rains were late in coming, each

of the chiefs of east Usambara sent a goat to the leader of the eastern Kilindi (the sons of Mnkande), to 'Kibanga, the greatest chief in the country, to ask him to bring the rain.'<sup>2</sup>

Kibanga had the nickname Zamgombezi, 'the charms of the fighter,' to which he answered, zaema mafuniko, 'they cannot be covered over.' This Proverb-name shows that in the 1870's and 1880's, when Kibanga was active, the opposition between conflict on the one hand, and 'covering over' on the other, was generally known.

The notion that political centralization leads to fertility and the increase of life is but one of a series of particular expressions of the more general Shambaa idea that a medicine man must 'own' the territory for which he makes rites, and that he must be able to defend himself and his territory against those envious of his possession.

Fika ya chekecheke, 'the sacrifice of the clinking bells' (see pp. 84f.), is another expression of the same general idea. At the beginning of the rite, which takes place at the house of the man whose paternal ghost must be propitiated, all those assembled walk out of the house, circle around, and re-enter, singing a song which indicates that the medicine man (who must be of another lineage) is the true owner of the house. The medicine man must 'own' the house in order to make rites for it. It is assumed that some of the men present will be envious, and will attempt to ensorcel the

medicine man, who must be powerful enough to protect himself and 'his' house, so that the rites may come to a successful conclusion. After everyone re-enters the house, and before the invocation of the ghost begins, the medicine man constructs a protective charm at the centre post of the house. He hammers three or four mivuti pegs (see p.294) into the earthen floor around the circumference of an overturned stool, with a pot sitting on its legs, which take the place of hearth stones. As he does this he sings about how he is hammering in protective charms. He then sings a threatening song about the disasters which will befall anyone who tries to ensorcel him. For as long as the rite continues, the medicine man acts as though he owns the house. He helps himself freely to sugar cane wine as though he were the host who made it. Like the King, the medicine man takes freely from the territory he protects. Like the King, he must cover over the homestead, so that no one attempts to attack him, for the medicine man must act alone for the rites to have their intended effect. The comparison between the King and the medicine man was made explicitly by Shambaa informants.

There are several pieces of evidence to show that the sacrifice of the clinking bells has undoubtedly existed since before the creation of the kingdom. There are a number of minor local variants of the rite, each of which, according to traditions, came into existence in the time of the pre-Kilindi ancestors. The trend, all through the history of the kingdom, has been for minor variations,

which are associated particularistically with individual descent groups, to drop away. In addition, the rite exists in this form not only in Shambaai, but among neighbouring peoples, In Bondei, to the east of Shambaai, the medicine man is called the mtani, 'the joking partner.' In all Bondei sacrifices, the mtani chooses his own food before the rest, and can eat alone or invite others (Dale 1895: 237-238). I suspect that the rite exists in a similar form among the Zigula.

Another particular expression of the same general idea is found in the magical fertility rites of the Mbagga medicine men from Pare, to the west of Shambaai. When the Mbagga came to Shambaai they were temporarily 'given' all the wealth of the land so that they would perform their rites for it successfully.<sup>3</sup>

The survival of the concepts kubana shi and kuzifya shi through the vicissitudes of the kingdom's history, through German conquest, British rule, and independence, shows clearly that the terms are not used as descriptions of inverting patterns of political action, but as categories of explanation and legitimation. One would expect this to be the case, even without historical evidence, because of the essential unpredictability of the relationship between the distribution of power and the fertility of the land. It would be remarkable indeed to find a regular precise fit in practice between a conception and a whole complex of political actions and natural events.

One obvious problem, in establishing the relationship between conceptions and action, is that the supremacy of the King is so highly valued, yet it is clear that there were times when Shambaa felt justified in plotting against their ruler. This problem has already been dealt with on pp.280,<sup>302,</sup> where it was shown that some of the men of Vugha worked for Shekulwavu's overthrow in the 1860's after Shekulwavu's inability to achieve a hierarchical configuration in relations between King and chiefs had been demonstrated. What was brought into question was not the position of the King, but Shekulwavu's ability to serve as a true King. In this sense, at least, there was a separation between the person and his office. Shekulwavu's position had been weakened by a major famine which had occurred in the year he occupied Vugha (Abdallah bin Hemedi '1Ajjemy 1963: Sura 69).

The belief, during the years that Shekulwavu was King, that power and fertility are tied together, can be understood quite simply with reference to the concept of the breaking of the land. In contrast to this, a real challenge to the persistence of Shambaa conceptions has existed over the past hundred years, ever since Shekulwavu's death, with the increasingly great separation between the fertility magicians and the holders of political power.

It will be remembered that after Shekulwavu's death, Semboja's son Kimweri Maguvu became King. No one, least of all Semboja or his descendants, has ever pretended that the house of Semboja had

possession or knowledge of the major rain charms, except for the kiza which was integrated into the design of Vugha, and to which any possessor of Vugha had access. Kimweri Maguvu had made the blood pact with Mtoi, the son of Mshuza of Ubii who had received a number of the most important rain charms of Kimweri ye Nyumbai. It was Mshuza, and after his death Mtoi, who made the magical rites for the fertility of Vugha. Here is how Kimweri Magogo, the most recent Simba Mwene, and a descendant of Semboja, described the dependence on Ubii: 'When the people had finished clearing and cultivating their gardens, they tilled the court's gardens. When they had finished, they went to receive the King's orders. The King would give them rolls of cloth and a she goat, and he would send along some of his officials. He said, "Go to pay my respects to that person at Ubii." The people would return to Vugha with the rain already falling. The next day, the people would go out to sow.'

In addition to the separation between political power and rain magic, there was drastic change in the sources of the King's support. There are important assumptions concerning the sources of a King's support, which are associated with the opposition between the repair and the breaking of the land. These assumptions are not unconscious; they are explicitly described by Shambaa informants. It is assumed that when the King covers over the land, and suppresses all opposition, making the land fertile, the ordinary people of Shambaa benefit, and in return they give the King their loyal and enthusiastic

support. The King's power depends, in the end, on the number of Shambaa who fight in his army, and on the number of Shambaa who pay tribute. Thus there is a community of interest between the King and the common people of Shambaai. The golden age of the alliance between King and commoners was the reign of Kimweri ye Nyumbai. The King was father of the chiefs, and therefore the commoners could appeal against the abuses of their chiefs. Kimweri ye Nyumbai's power was unassailable because he could mobilize all the fighting men of Shambaai, and he 'ate' the tribute of all Shambaai. Because Kimweri ye Nyumbai covered over the land, he was able to maintain the fertility of the land and provide food for all his loyal subjects. It seems that this description of Kimweri ye Nyumbai's rule is not only an important political legend, but a moderately accurate description of the sources of his support.

During the reign of Kimweri Maguvu, however, in the 1870's and 1880's, with the growing importance of the slave trade and of firearms, the alliance between King and commoners was destroyed. It became possible for the King, and especially his father Semboja, to rely on a few men with firearms rather than massed Shambaa armies with spears. Often the fighters were not Shambaa at all. Semboja's fighting force was largely Zigula. It became possible to reward the fighters with exotic trade goods obtained through the sale of Shambaa as slaves, and so the tribute drawn from Shambaai was not as important as it had been. In addition, the

trade routes were all in the plains. Where earlier the highly populated mountain area had been most important for the King's support, now the sparsely settled plains, occupied by aliens, became essential.<sup>4</sup> The point of this is that the community of interest between Shambaa and their King, on which all the ideas of rain magic depended, no longer existed.

There are two Shambaa interpretations of the politics of the period. The first, agreed upon by almost all the informants I spoke with, is given in the following quotation from the statement of a former court official:

The Arabs traded with Semboja. Their merchandise was people. That is why the Arabs found a way of entering the affairs of the Shambaa. The Arabs were not involved in our affairs in the days of Kimweri ye Nyumbai. Their merchandise was people. In the days of ye Nyumbai there were no enemies.

In other words, the slave traders came to Shambaa because of the conflict among Kilindi. This is the reverse of modern causal historical reasoning. We would say that there was political conflict because of the responses of leaders to new trade conditions. The Shambaa say that the trade was a result of force against force.

The second interpretation, one given much less frequently, is that Semboja was a completely deviant kind of political leader. 'The one who broke the ritual prohibitions (miiko) of the Kilindi is Semboja, when he sold people and made war.' The sense of shock at Semboja's willingness to ignore the community of interest between Kilindi and Shambaa is expressed in a remark, attributed to the Shambaa, in discussion with Semboja: 'Once you have finished killing

all the people of the country, who will your subjects be?' There is evidence that Semboja encouraged this view, that he was willing to make known his break with the Kilindi past. Semboja violated, and openly acknowledged his violation of, the prohibition against farming during the mourning for his father, Kimweri ye Nyumbai (Abdallah bin Hemedi 'lAjemy 1963: Sura 73).

The period of the slave trade lasted for no more than twenty years before the Germans conquered Shambaai, and so even those few Shambaa who see Semboja's rule as a break with the Shambaa tradition of government, see it as a temporary aberration. The German conquest, however, brought a drastic separation not only between political power and possession of rain charms, but between the Kilindi and power.

The most traumatic event of modern Shambaa history occurred on April 30th, 1895. At that time there were German troops at Mazinde, but they had no real control over the affairs of Shambaai. The King was Mputa, the brother of Kimweri Maguvu, who had died more than a year before. Semboja had died the month before. All the Kilindi chiefs were brought to Mazinde. The chief of Mbaramu, who was too ill to walk, had been brought on a litter. The King was pronounced guilty of murder, since he had killed the lover of one of his wives. Before most of the Kilindi of Shambaai, and many of the important men of Vugha, the Simba Mwene was hung. It is this act which most Shambaa men who were alive at the time see as

having effected the transfer of power from the Kilindi to the Germans. The word nguvu, 'force,' or 'power,' recurs in the oral accounts. The German officer in charge, Lieutenant Storch, nicknamed Matungika ('the piercer,' or 'the stabber,' because of the hook under the hanging corpse's chin) is quoted in one typical account as having said to the Kilindi, 'If you have any nguvu, let me see it now.' No one showed nguvu, and control passed from the Kilindi.<sup>5</sup>

The people of Vugha reacted to Mputa's death with panic. Many slept out in the open for several nights, hidden in thickets, for fear of what would happen to them. Once the initial period of panic had passed, the officials of Vugha arranged a rotation, as for casual court service, so that the people of different quarters of the capital took turns attending the church which had been built about two miles from the capital.<sup>6</sup>

After a brief interlude, Kinyashi son of Shekulwavu, (the Shekulwavu who had been driven out of Vugha and then killed by Semboja) was installed as King of Vugha. His position was impossible, for the local German officer, and the plantation interests which were moving into Shambaai, felt that the death of Mputa had established their authority, and that Kinyashi was their agent. He was forced to provide great numbers of labourers for both the government and private employers, and he was forced to sell great pieces of land for plantations. Initially hundreds of workers went out

at Kinyashi's command, but then the people of Vugha simply stopped obeying him. When the people would no longer respond to his commands, the German officer cut his salary. Kinyashi acceded in September 1895. By July 1896, a missionary heard a woman loudly singing at Vugha, Kigono cha shimba, chagona nguluwe: 'Where once a lion slept, there is now a pig.' This was the most terrible insult to which a King could be subjected. While the King should be like a lion, who eats the meat of the whole land as tribute when he covers it over, Kinyashi was like a pig who roots up the crops. It must have been at about this time that Kinyashi stopped performing rites for the fertility of the land at the court.<sup>7</sup> Vugha declined in this period. In 1897 more than half the houses of Vugha were empty. In September 1898 there was a great fire which destroyed half of the capital, and no one made any attempt to rebuild.

Then, in 1898 and 1899, there came a series of disasters which lasted for over a full year. First, jiggers spread to Shambaai for the first time ever. Since Shambaa did not know how to deal with them, thousands of people became seriously ill from jigger investation. Then came locusts and then a very long drought, with people dying from hunger on the roadsides as they went searching for food. The famine was worst at Vugha. Finally, with the population weakened from hunger, there came an epidemic of small-pox.

It is difficult to know what the Shambaa thought were the causes of disaster. Informants today stereotype Kinyashi's rule with reference to his characteristics as King after his restoration in the 1920's (see below). There is some evidence that, with the decline of Kinyashi's prestige, the Shambaa expected the Europeans to be their new rain magicians -- that control over the fertility of the land would continue to be associated with political power in a direct way. In 1896, Kinyashi himself went to Vugha's missionary, and asked him to pray for rain.<sup>8</sup> In June of 1897, people of a village near Vugha offered the missionary a sheep, so that he would make magic for the livestock of the land as though it were his own.<sup>9</sup>

The jiggers were unknown to Shambaa medicine men because they had never existed before in Shambaai, but the Europeans knew how to treat the infestation. The missionaries treated thousands of cases, and they reported that the medicine men were discredited.<sup>10</sup> There is a tradition told these days that jiggers were unknown in Shambaai before an angry German brought an earthen pot full from Europe, and broke it in the plains. At the beginning of the famine, in 1898, when locusts first came, the Mbaga locust magician came to Shambaai, where he spread the rumour that he had been called in by the Europeans (Gleiss 1898: 129).

It is possible, in other words, that the Shambaa saw the disasters of 1898-1899 as the result of a German plan to demonstrate

to the Shambaa their own powerlessness, and to make them completely dependent on Europeans. This interpretation is no longer remembered because the Europeans' subsequent lack of interest in rain magic showed the notion to be inappropriate. This interpretation would explain why the Shambaa did not appeal to the Kilindi ancestors at the time. No commoner lived at Vugha during the famine.

In 1899, after the famine had been going on for a year, a Shambaa told a story about a giant named Hunju to one of the two most senior missionaries in Shambaa. The missionary recorded it as an interesting folk tale, but I suspect that it was told as a parable, in warning. It is the following tale (Johanssen 1899):

A long time ago a terrible giant named Hunju lived on the earth and made all men his subjects. If he went into a town and demanded anything, the people gave him whatever he wanted, be it cattle or men. No one trusted himself to come near him, and no town tried to beat him off, or to kill him with an arrow shot from afar. His size was indescribable, for when he went through the sea he didn't need to swim, and if he seized a sea monster he held it up and roasted it in the sun in order then to eat it. His brushing stick for his teeth was the size of a big tree. One day he came to a town and asked for a herd of cows for his hunger. They were terribly afraid and begged for his pity, for they could not give him cows since they had none. But Hunju became furious and reproached the people, saying they had hidden their cattle from him. He left in anger, and resolved to make an example of the people, so no town would ever have the courage to hide something from him. He went into the mountains and lifted a stone slab, large enough to cover the whole town. He put it on his head and went down the mountain to flatten the town. God saw him, and the haughtiness and godlessness of Hunju, who thought himself God, annoyed him. Therefore, God made a hole in the slab, right where it rested on Hunju's head, so that with a terrible jerk the giant's head broke through, and the slab rested on his shoulders. Vainly he tried to

lift it and pull his head back through, to remove the load from his shoulders. But it did not move. As far as his eyes could see there was only stone slab; his hands could not come to his mouth, so he could not eat. Three months he went like this without eating, for his strength was great; when he then tried to rise to his feet he died. The load had killed him.

In 1902, the remainder of Vugha burned, and Kinyashi retired to private life. In the succeeding years the Germans lost their part of east Africa, and the Shambaa appear to have accepted the notion that Europeans did not know or care about controlling the fertility of the land. When, with the establishment of indirect rule, there seemed a possibility of restoring Kinyashi to Vugha, the overwhelming majority of Shambaa were delighted. They wished to have a rain magician as King (for they saw the possessor of Vugha as Simba Mwene; they did not introduce a Shambaa equivalent to the term paramount chief), even though they knew the King would have little real power. In December 1925, during the period the Shambaa were being consulted on the choice of their leader under indirect rule, the short rains broke on the day of Kinyashi's appearance at Mlola (a chiefdom capital), and there were 'extraordinary demonstrations.' In January 1926 a lion appeared at Vugha, the first lion seen there for many years. It killed a cow fifty yards from Kinyashi's house, left the carcass uneaten, returned the next night and was easily shot.<sup>11</sup> Both these occurrences were excellent omens, and the Shambaa appear to have been delighted at the prospect of Kinyashi's return.

The three years Kinyashi held office, from 1926 to 1929 were years without famine, and Kinyashi's reputation today is as a great rain magician. Kinyashi himself, during his years in office, apparently took his work as a rain magician seriously, and he made a strict separation between rain magic and political power. He saw himself as holding the one but not the other. All Shambaa knew that Kinyashi could not make war, could not sentence people to death, and could not freely collect tribute. But Kinyashi himself refused to accept gifts from his subjects whose cases he was judging, and he reportedly saved his entire salary, recounting it carefully from time to time, so that when the District Officer fired him, he would be able to return it all.

The Shambaa continued to believe in the efficacy of Kilindi rain charms even though no Kilindi any longer held the power of death, or owned all the wealth of the land. It was considered important, however, for the rain magician to hold the chief's (or "King's") office, and especially to have possession of the capital with its shrines. When a chief who was famous as a rain magician (whose name I cannot mention), was returned after a period out of office, a number of the most influential people of his chiefdom instructed him not to risk losing his office by opposing the District Commissioner on any issue. In other words, it was more important for the rain magician to hold the office without power, than it was to risk the office in order to influence decisions on

public affairs. The political importance of the rain magic, however, was that any potential rival for the chiefship would face powerful opposition, approaching open rebellion, from the people of the chiefdom.

I am choosing not to discuss the role of Shambaa political conceptions and rain magic in the Tanganyika independence movement because it is a large and complex problem which would best be treated at great length, because it is a politically sensitive topic on which anything I write might affect the well being of a number of men, and because such a discussion would not alter the main point being made here. That is, kubana shi and kuzifya shi have survived as categories of explanation, even though the forms of political organization have changed drastically since colonial conquest.

It is important to note that the categories were still in common use during the period of my field research, between 1966 and 1968, although independence had come to Tanganyika at the end of 1961, and the posts of chiefs had been abolished at the end of 1962. An example will illustrate the way in which the conceptions, and their political importance, have survived.

I was living in an area which had formerly been a chiefdom, and was now a Division, of the Area (formerly District) of Lushoto. The former chief, who had retired to private life, had a great reputation as a rain magician. While I was living there, the time

for the rains came and passed without any rain falling. There were two interpretations given for the natural event. The people with whom I was living thought that there were competing rain magicians, who were envious of the former chief. The chief's competitors, according to my neighbours, were holding back the rain. The Divisional Executive Officer, on the other hand, seemed to fear that the people of his division would believe the drought was caused by the former chief himself, to show that he, and not the new TANU appointees, was the man to be feared and respected locally. In either case, the drought resulted from 'force against force' which 'broke the land.'

The Executive Officer (who was a Shambaa) arrested and imprisoned two of the sons of the rain magician to show that he, the new appointee, had covered over the land, and that the former chief could not challenge his authority. The chief responded by saying that he had given up practicing rain magic long ago, that he had converted to Christianity, and that the Divisional Officer had misunderstood his position entirely. The former chief invited the local lay evangelist to hold a prayer meeting, so that the people of the neighbourhood could pray together for rain. In a way, this prayer meeting was meant to function, in a modern context, in the same way that the payment of tribute functioned in the pre-colonial context. Everyone present would show that he had no intention of holding back the rain. It was a small prayer meeting with about fifteen

people. The importance of it was, however, that the former chief attended and prayed.

I was invited to the prayer meeting. Perhaps it was because I was present on that day, collecting historical traditions, perhaps it was so that I could be a semi-official witness. We stood together in a circle, outdoors, at the edge of the former chief's village. The lay evangelist began to recite prayers. Then, a few feet away from the circumference of our circle, a poisonous snake appeared, and everyone began to shout, Sheitani, Sheitani, 'Satan, Satan.' There was the Satan who had held back the rain. Even in a Christian context, famine was the result of opposing forces.

Several days after the prayer meeting, the former chief's sons were released. The famine continued, and then the next farming season there were good rains again. The Executive Officer had shown that his political power was irresistible. The chief had agreed. The people of Shambaai would agree more emphatically if the Executive Officer had rain charms.

This historical survey should not lead one to the conclusion that at one time ('the golden age') there was a perfect correspondence between the distribution of power and the distribution of rain charms, while these days the two have separated, and rain charms are a mere survival. At no time can there be a perfect correspondence between the structure of political ideas and the

organization of concrete political actions, because political leadership is essentially the art of dealing with the unexpected and unpredictable in the public realm. If the Shambaa could have predicted and controlled all the forces affecting their fate as a people, then there would have been no need for a King as the Shambaa understood his position. They would have needed only a priesthood. Their conceptions could then have been detailed schemes with invarying concomitants in action. Because of the unpredictability of public events, there had to be a loose correspondence between ideas on the one hand, and the distribution of power among groups and individuals on the other. As it was, the ideas could be used to justify courses of action, and they gave order and meaning to the public experience of famine and of political conflict.

The symbols of kingship, while concrete and unchanging, were ambivalent. The discursive Shambaa explanations of how to achieve an increase of life for the people of the kingdom were ambiguous. Given the drastic fluctuations of political action from one generation to the next, they could not have survived had they not been ambiguous. By separating ideas from action, and examining their interrelations, it has been possible to show why Shambaa ideas are not dead archaisms in the world of the twentieth century, and to demonstrate the mechanism by which continuity exists in the changing world of African politics.

## FOOTNOTES

<sup>1</sup>Universities Mission to Central Africa, Bluebook, 1868.

<sup>2</sup>Central Africa, June 1884, p. 101.

<sup>3</sup>This is described in oral traditions and confirmed by materials from the Bethel Mission archives, Tagebuch Hohenfriedeberg, 4 July 1895, and in a published account by a Bethel missionary (Gleiss 1898).

<sup>4</sup>The evidence for these changes is discussed in Feierman 1970: chapter vii.

<sup>5</sup>This account is based largely on oral accounts, but it is described also by Lieutenant Storch Nachrichten aus der ostafrikanischen Mission, September 1895, pp. 138-140. The occurrence is also mentioned in Vugha's station diary in the Bethel Mission archives.

<sup>6</sup>The events of the period are recorded in the Vugha station diary of the Bethel Mission. There is an excellent description in LangHeinrich 1902, and there are fragments in Gleiss 1928.

<sup>7</sup>Bethel Mission, Tagebuch Wuga, 16 July 1896, 24 Jan 1896.

<sup>8</sup>Bethel Mission, Tagebuch Wuga, 24 February 1896.

<sup>9</sup>Bethel Mission, Tagebuch Wuga, 4 June 1897.

<sup>10</sup>Wohlrab 1915: 61. Nachrichten aus der ostafrikanischen Mission, September 1899, p. 162.

<sup>11</sup>Rhodes House, MSS Afr. s. 462, 'Proposal for Usambara District Native Administration,' by W.S.G. Barnes.

## BIBLIOGRAPHY

- Abdallah bin Hemedi 'lAjemy.  
1962. Habari za Wakilindi. Edited by J. W. T. Allen and William Kimweri bin Mbago. Nairobi.
1963. The Kilindi. Translated by J. W. T. Allen and William Kimweri bin Mbago. Nairobi.
- Allen, G. M. and Loveridge, A.  
1927. "Mammals from the Uluguru and Usambara Mountains." Proceedings of the Boston Society of Natural History, XXXVIII, 413-441
- Anonymous.  
1939. "Salt Production among the Wasambaa." Tanganyika Notes and Records, No. 8, 102-103.
- Apter, David.  
1961. The Political Kingdom in Uganda. Princeton.
- Arendt, Hannah.  
1965. Eichmann in Jerusalem: a Report on the Banality of Evil. Revised ed. New York.
- Attens, Manfred.  
1967. Bauernbetriebe in tropischen Höhenlagen Ostafrikas. (IFO Institut für Wirtschaftsforschung, Afrika Studien, Nr. 25.) Munich.
- Baker, E. C.  
1935. Report on Social and Economic Conditions in the Tanga Province. Dar es Salaam.
- Balandier, Georges.  
1969. Anthropologie Politique. Paris.

Baumann, Oscar.

- 1889a. "Usambara." Dr. A. Petermanns Mitteilungen aus Justus Perthes Geographischer Anstalt, XXXV, 41-47.
- 1889b. "Karte von Usambara." Dr. A. Petermanns Mitteilungen aus Justus Perthes Geographischer Anstalt, XXXV, 257-261.
1890. In Deutsch-Ostafrika während des Aufstandes. Wien und Olmütz.
1891. Usambara und seine Nachbargebiete. Berlin.

Becker.

1896. "Das Hauptopferfest der Waschambaa." Nachrichten aus der ostafrikanischen Mission, X, no. 12, pp. 177-181.

Becker, Dr. A.

1911. Aus Deutsch-Ostafrikas Sturm und Drangperiode. Halle.

Beidelman, T. O.

1966. "Swazi Royal Ritual." Africa, XXXVI, 373-405.
1971. "Nuer Priests and Prophets: Charisma, Authority and Power among the Nuer." In T.O. Beidelman (ed.), The Translation of Culture: Essays to E.E. Evans-Pritchard. London.

Bellah, Robert N.

1964. "Durkheim and History." In W. J. Cahnman and A. Boskoff (eds.), Sociology and History. Glencoe, Illinois.

Bellville, Alfred.

- 1875-1876. "Journey to the Universities' Mission Station of Magila on the Borders of the Usambara Country." Proceedings of the Royal Geographical Society, XX, 74-78.

Bethel Mission.

1930. Ushimolezi: Schambala Lesebuch. Vugha (Tanganyika).

Boteler, Capt. Thomas.

1835. Narrative of a Voyage of Discovery to Africa and Arabia performed in His Majesty's Ships Leven and Barracouta from 1821 to 1826 under the Command of Capt. F. W. Owen. 2 vols. London.

Buchwald, Johannes.

1897. "Westusambara, die Vegetation und der wirtschaftliche Werth des Landes." Der Tropenpflanzer, I, 58-60, 82-85, 105-108.

Burton, Richard F.

1872. Zanzibar: City, Island, and Coast. 2 vols. London.

Burton, Richard F., and J. H. Speke.

1858. "A Coasting Voyage to the Pangani River; Visit to Sultan Kimwere; and Progress of the Expedition into the Interior." Journal of the Royal Geographical Society, XXVIII, 188-226.

Cliffe, Lionel.

1970. "Traditional Ujamaa and Modern Producer Co-operatives in Tanzania." In C. G. Widstrad (ed.), Cooperatives and Rural Development in East Africa, pp. 39-60. New York.

Cliffe, Lionel, William L. Luttrell, and John E. Moore.

1969. "Socialist Transformation in Rural Tanzania - a Strategy for the Western Usambaras." (Rural Development Research Committee, University College Dar es Salaam, Rural Development Paper No. 6.)

Cohen, Abner.

1969. "Political Anthropology: the Analysis of the Symbolism of Power Relations." Man, 215-235.

Copeland, B. D.

1957. "Notes on the Officials of the Kilindi Kingdom and the First Rulers." Journal of the East African Swahili Committee, No. 27, pp. 64-65.

Cory, Hans.

1951. "Sambaa Law and Custom." Typescript, revised and edited by E. B. Dobson. Copy in the Cory Collection, University of Dar es Salaam.

1956. African Figurines: their Ceremonial Use in Puberty Rites in Tanganyika. London.

- 1962a. "The Sambia Initiation Rite for Boys." Tanganyika Notes and Records, Nos. 58-59, pp. 2-7.
- 1962b. "Tambiko (Fika)." Tanganyika Notes and Records, Nos. 58-59, pp. 274-282.
- Dahl, Robert A.  
1968. "Power." International Encyclopedia of the Social Sciences, vol. 12, pp. 405-415. U.S.A.
- Dahlgrün, H.  
1903. "Heiratsgebräuche der Schambaa." Mitteilungen aus den Deutschen Schutzgebieten, XVI, 219-230.
- Dale, Godfrey.  
1895. "An Account of the Principal Customs and habits of the Natives inhabiting the Bondei Country." Journal of the Anthropological Institute. pp. 181-239.
- Dammann, Ernst.  
1937-1938. "Bonde-Erzählungen." Zeitschrift für Eingeborenen-Sprachen, XXVIII, 299-318.
- Dobson, E. B.  
1940. "Land Tenure of the Wasambaa." Tanganyika Notes and Records, No. 10, pp. 1-27.  
1954. "Comparative Land Tenure of Ten Tanganyika Tribes." Journal of African Administration, VI, No. 2, pp. 80-91.
- Döring, P.  
1900a. Lehrlingsjahre eines jungen Missionars in Deutsch-Ostafrika. Berlin.  
1900b. Hohenfriedeberg: eine Missionsstation in Usambara. Berlin.  
1901. Morgendämmerung in Deutsch-Ostafrika. Berlin.  
1948. "Unter seinen Flügeln." Typescript in the Bethel Mission archives.

- Douglas, Mary.  
 1966. Purity and Danger. London.
1967. "Primitive Rationing: a study in controlled exchange." In Themes in Economic Anthropology, edited by Raymond Firth, pp. 119-147.
- Dupré, H.  
 n.d. "Land und Volk in Usambara." Manuscript at the Bethel Mission archives.
- Durkheim, E.  
 1953. Sociology and Philosophy. London.
- Durkheim, E. and M. Mauss.  
 1963. Primitive Classification. Translated and edited by Rodney Needham. London.
- Easton, David.  
 1959. "Political Anthropology." In Bernard J. Siegel (ed.), Biennial Review of Anthropology, 1959, pp. 210-262. Stanford.
- East African Statistical Department.  
 1958. Tanganyika Population Census, August 1957. Nairobi.
- Evans, Pritchard, E. E.  
 1971. The Azande: History and Political Institutions. Oxford.
- Ekemode, G. O.  
 1968. "Kimweri the Great." Tarikh, II, No. 3, pp. 41-51.
- Farler, J. P.  
 1878. The Work of Christ in Central Africa: a Letter to the Rev. H. P. Liddon. London.
1879. "The Usambara Country in East Africa," Proceedings of the Royal Geographical Society, new series, I, 81-97.
1882. "Native Routes in East Africa from Pangani to the Masai Country and the Victoria Nyanza." Proceedings of the Royal Geographical Society, new series, IV, 730-742, 776.

1885. Letters to the editor, The Times (London), October 16, and November 13.
- Feierman, Steven.  
 1968. "The Shambaa." In Tanzania before 1900, edited by Andrew Roberts, pp. 1-15.
1970. "The Shambaa Kingdom: a History." Unpublished Ph.D. thesis, Northwestern University. Evanston, Illinois.
- Fortes, Meyer.  
 1945. The Dynamics of Clanship among the Tallensi. Oxford.
- Gabel, Creighton, and Bennett, Norman R.  
 1967. Reconstructing African Culture History. Boston.
- Gennep, Arnold van.  
 1960. The Rites of Passage. Translated by Monika B. Vizedom and Gabrielle L. Caffee. London.
- Gleiss, Franz.  
 1898. "Magili, der Herr der Heuschrecken." Nachrichten aus der ostafrikanischen Mission, XII, 128-130.
1908. Schambala-Sprachführer. Tanga (Deutsch-Ostafrika).
1926. An meinen Hirten! Bethel bei Bielefeld.
1928. Vor den Toren von Wuga. Bethel bei Bielefeld.
- Gluckman, Max.  
 1963. Order and Rebellion in Tribal Africa. New York.
- Haberlandt, M.  
 1900. "Dr. Oskar Baumann, ein Nachruf (mit Bild)."  
Abhandlungen der K. K. Geographischen Gesellschaft in Wien, II, 1-20.
- Heanley, R. M.  
 1909. A Memoir of Edward Steere. London.
- Holst, Carl.  
 1893a. "Der Landbau der Eingeborenen von Usambara."  
Deutsche Kolonialzeitung, VI, 113-114, 128-130.

- 1893b. "Die Kulturen der Waschambaa." Deutsche Kolonialzeitung, VI, 23-24.
- 1893c. "Zur Klimakunde von Hochusambara." Mitteilungen aus den Deutschen Schutzgebieten, VI, 93-102.
- Hosbach, W.  
1911. "Eine Geistergeschichte." Nachrichten aus der ostafrikanischen Mission, XXV, 209-213.
1923. Abraham Kilua, der schwarze Vikar von Neu-Bethel. 2d ed. Bethel bei Bielefeld.
- Hoza, Yohana.  
n.d. "Sheuta: Dini ya Kishambala, au Miviko ya Kishambala." Manuscript in the present writer's possession.
- Hubert, H., and Mauss, M.  
1929. "Étude sommaire de la représentation du temps dans la religion et la magie." In H. Hubert and M. Mauss, Mélanges d'histoire des religions, pp. 189-229. Paris.
- Johanssen, Ernst.  
n.d. Führung und Erfahrung in 40 jährigem Missionsdienst. Vols. I and II. Bethel bei Bielefeld.
1899. "Der Riese Hundju." Nachrichten aus der ostafrikanischen Mission, XIII, 203-204.
- Johanssen, Ernst, and Döring, Paul.  
1914-1915. "Dan Leben der Schambala, beleuchtet durch ihre Sprichwörter." Zeitschrift für Kolonialsprachen, V, 137-150, 190-226, 306-318.
- Johnston, H. H.  
1886. The Kilima-Njaro Expedition. London.
- Johnston, Keith.  
1879. "Notes of a Trip from Zanzibar to Usambara, in February and March 1879." Proceedings of the Royal Geographical Society, new series, I, 545-564, 616.

- Kähler-Meyer, E.  
1962. "Studien zur tonalen Struktur der Bantusprachen." Afrika und Uebersee, XLVI, 1-42.
- Kallenberg, Friedrich.  
1892. Auf dem Kriegspfad gegen die Massai. München.
- Kaniki, Marko.  
1903. "Bestattung der grossem Kilindi." Nachrichten aus der ostafrikanischen Mission, XVII, 190-191.
- Karasek, A.  
1908. "Tabakspfeifen und Rauchen bei den Waschambaa." Globus, pp. 285-287.
- 1911-1924. "Beiträge zur Kenntnis der Waschambaa." Edited by August Eichhorn, for Baessler-Archiv, as follows:  
1911. Part 1. I, 155-222.  
1913. Part 2. III, 69-131.  
1918-1922. Part 3. VII, 56-98.  
1923-1924. Part 4. VIII, 1-53.
- Kersten, Otto.  
1869. Baron Carl Claus von der Decken's Reisen in Ost-Afrika in den Jahren 1859 bis 1861. Vol. I. Leipzig und Heidelberg.
- Kirk, John.  
1873. "Visit to the Coast of Somali-land." Proceedings of the Royal Geographical Society, XVII, 340-341.
- Koch, Robert.  
1953. "Report on West Usambara from the Point of View of Health (5/8/1898)." Tanganyika Notes and Records, No. 35, pp. 7-13.
- Koritschoner, Hans.  
1936. "Details of a Native Medical Treatment." Tanganyika Notes and Records, No. 2, pp. 67-71.

Krapf, Johann.

1863. An excerpt from Krapf's journal in the United Methodist Free Churches Magazine, p. 300.
1964. Reisen in Ostafrika. Stuttgart. A reprint of the edition of 1858. This work is translated and abridged as Travels, Researches, and Missionary Labours during an Eighteen Years' Residence in Eastern Africa. London, 1860.

Lamphear, John.

1970. "The Kamba and the Northern Mrima Coast." In Pre-Colonial African Trade, edited by Richard Gray and David Birmingham, pp. 75-101. London.

LangHeinrich, F.

- n.d. "Wie ich Missionar wurde." Typescript in the Bethel Mission archives.
1902. "Vergangene Pracht." Nachrichten aus der ostafrikanischen Mission, XVI, 73-78.
1903. "Die Waschambala." In Rechtsverhältnisse von eingeborenen Völkern in Afrika und Ozeanien, edited by S. R. Steinmetz, pp. 218-267. Berlin.
1913. "Die Entwicklung des Verkehrs in Westusambara." Nachrichten aus der ostafrikanischen Mission, XXVII, 7-12.
1921. Schambala-Wörterbuch. ("Abhandlungen des Hamburgischen Kolonialinstituts," Band XLIII.) Hamburg.

Leach, Edmund

1954. Political Systems of Highland Burma: a Study of Kachin Social Structure. London.
1958. "Magical Hair." Journal of the Royal Anthropological Institute, LXXXVIII, 147-164.

Lemenye, Justin.

1953. Maisha ya Sameni Ole Kivasis, yaani Justin Lemenye. Edited by H. A. Fosbrooke. Nairobi.

- Le Roy, Alexandre.  
n.d. Au Kilima-Ndjaro. Paris.
- Lévi-Strauss, Claude.  
1966. The Savage Mind. Chicago. Translated from the French, La Pensée Sauvage, Paris, 1962.
- Lloyd, Peter C.  
1965. "The Political Structure of African Kingdoms." In Political Systems and the Distribution of Power (ASA Monographs no. 2), edited by Michael Banton, pp. 63-112. London.
- McCall, Daniel F.  
1969. Africa in Time Perspective: a Discussion of Historical Reconstruction from Unwritten Sources. New York.
- Meeussen, A. E.  
1955. "Tonunterschiede als Reflexe von Quantitätsunterschieden im Schambala." In Afrikanistische Studien, edited by J. Lukas, pp. 154-156.
- Meyer, Hans, and Baumann, Oskar.  
1888. "Dr. Hans Meyer's Usambara Expedition." Mitteilungen aus den Deutschen Schutzgebieten, I, 200-205.
- Milne, G.  
1944. "Soils in Relation to Native Population in West Usambara." Geography, XXIX, 107-113.
- Moreau, R. E.  
1941. "Suicide by 'Breaking the Cooking Pot.'" Tanganyika Notes and Records, No. 12, pp. 49-50.
- Mwakyosa, D. A.  
1947. "The Rule of Witch-Craft among the Wasambaa." Makerere, I, 121-123.
- Needham, Rodney.  
1958. "A Structural Analysis of Purum Society." American Anthropologist, LX, 75-101.  
1960. "The Left Hand of the Mugwe: An Analytical Note on the Structure of Meru Symbolism." Africa, XXX, 20-33.

1963. Introduction to Primitive Classification, by Émile Durkheim and Marcel Mauss, pp. vii-xlvi.
- New, Charles.  
 1873. Life, Wanderings, and Labours in Eastern Africa. London.  
 1875. "Journey from the Pangani, via Wadigo, to Mombasa." Proceedings of the Royal Geographical Society, XIX, 317-323.
- Owen, W. F. W.  
 1833. Narrative of Voyages to Explore the Shores of Africa, Arabia, and Madagascar. Edited by Heaton Bowstéad Robinson, London.
- Parsons, Talcott.  
 1960. Structure and Process in Modern Societies. London.  
 1963. "On the Concept of Political Power." Proceedings of the American Philosophical Society, CVII, 232-262.
- Peters, Karl.  
 1895. Das Deutsch-Ostafrikanische Schutzgebiet. München und Leipzig.
- Picarda, Père.  
 1886. "Autour de Mandéra: Notes sur l'Ouzigoua, L'Oukwere, et L'Oudoé (Zanguebar)." Les Missions Catholiques (Lyons), XVIII, 184-189, 197-201, 208-211, 225-228, 234-237, 246-249, 258-261, 269-274, 281-285, 294-297, 322-325, 332-334, 342-346, 356-357, 365-369.
- Pirenne, Henri.  
 1956. Medieval Cities: their origins and the revival of Trade. Translated by Frank D. Halsey. Garden City, New York.
- Richards, Audrey I.  
 1961. "African Kings and their Royal Relatives." Journal of the Royal Anthropological Institute, XC, 135-150.
- Riese, F.  
 n.d. "Die Opfer der Schambala." Manuscript at the Bethel Mission archives. 1911. Etwas über die Mysterien der Schambala. Bethel bei Bielefeld.

- Roehl, Karl.  
1911. Versuch einer systematischen Grammatik der Schambala-  
sprache. ("Abhandlungen des Hamburgischen Kolonial-  
instituts," Band II.) Hamburg.
- Rösler, Frau Missionar O., and Gleiss, Franz.  
1912. Schambala-Grammatik. ("Archiv für das Studium  
deutscher Kolonialsprachen," Band XIII.) Berlin.
- Sangai, G. R. Williams.  
1963. Dictionary of Native Plant Names in the Bondei,  
Shambaa, and Zigua Languages with their English and  
Botanical Equivalents. Nairobi: by the East African  
Herbarium.
- Seidel, A.  
1895. Handbuch der Schambalaspache in Usambara. Leipzig.
- Smith, M. G.  
1962. "History and Social Anthropology." Journal of the  
Royal Anthropological Institute, XCII, 73-85.
- Soper, R. C.  
1967. "Iron Age Sites in North-Eastern Tanzania." Azania,  
II, 19-36.
- Southall, Aidan.  
1956. Alur Society. Cambridge.
- Speke, John Hanning.  
1967. What Led to the Discovery of the Source of the Nile.  
London.
- Stanley, Henry M.  
1872. How I Found Livingstone: Travels, Adventures, and  
Discoveries in Central Africa. New York.
- Steere, E.  
n.d. First Freed Slave Settlement in Central Africa.  
("Central African Mission," Occasional Paper No. 7)  
London.
1867. Collections for a Handbook of the Shambala Language.  
Zanzibar.

- Storch, E.  
 1895a. "Sitten, Gebräuche und Rechtspflege bei den Bewohnern Usambara und Pares." Mitteilungen aus den Deutschen Schutzgebieten, VIII, 310-331.
- 1895b. "Ueber das Strafverfahren gegen des Jumben Mputa von Wuga und über die Einsetzung des Jumben Kipanga von Handei in Wuga." Nachrichten aus der ostafrikanischen Mission, IX 139-140.
- Swartz, Marc, Turner, Victor and Tuden, Arthur eds.  
 1966. Political Anthropology. Chicago.
- Sykes, Colonel.  
 1853. "Notes on the Possessions of the Imaun of Muskat, on the Climate and Productions of Zanzibar, and on the Prospects of African Discovery from Mombas." Journal of the Royal Geographical Society, XXIII, 101-119.
- Thornton, Richard.  
 1865. "Notes on a Journey to Kilima-ndjaro, made in the Company of the Baron von der Decken." Journal of the Royal Geographical Society, XXXV, 15-21.
- Thurnwald, Richard C.  
 1935. Black and White in East Africa. London.
- Turner, Victor.  
 1967. The Forest of Symbols. Ithaca.
- Vansina, Jan.  
 1962. "A Comparison of African Kingdoms." Africa XXXII, 324-335.
1965. Oral Tradition. Chicago.
1968. "The Use of Ethnographic Data as Sources of History," in T. O. Ranger (ed.) Emerging Themes of African History. 97-123. Dar es Salaam.
- Vansina, Jan, Mauny, Raymond, and Thomas, L. V.  
 1964. The Historian in Tropical Africa. London.
- Vickers-Haviland, L. A. W.  
 1938. "The Making of an African Historical Film." Tanganyika Notes and Records, No. 6, 82-26.

- Walker, Ernest P. et al.  
1964. Mammals of the World. 3v. Baltimore.
- Walter, E. V.  
1969. Terror and Resistance: A Study of Political Violence. London.
- Ward, Gertrude.  
1898. The Life of Charles Alan Smythies. Edited by Francis Russell. London.
- Weber, Max.  
1947. The Theory of Social and Economic Organization. New York.
- Werner, Alice.  
1933. Myths and Legends of the Bantu. London.
- Whiteley, W. H.  
1958. A Short Description of Item Categories in Iraqw. Kampala.  
1960. "Linguistic Hybrids." African Studies, XIX, 95-97.
- Wilson, George Herbert.  
1936. The History of the Universities Mission to Central Africa. London.
- Winans, Edgar V.  
1962. Shambala: the Constitution of a Traditional State. London.  
1964. "The Shambala Family," in The Family Estate in Africa, edited by Robert F. Gray and P. H. Gulliver 35-61. London.
- Wohlrab, Karl.  
1929. Die christliche Missionspredigt unter den Schambala. Tübingen.
- Wohlrab, Paul.  
1913. "Ein Neuer Dämonen-Kultus in Usambara." Nachrichten aus der ostafrikanischen Mission, XXVII, 186-189.

1915. Usambara: Werden und Wachsen einer heidenchristlichen Gemeinde in Deutsch-Ostafrika. Bethel bei Bielefeld.
1918. "Das Recht der Schambala." Archiv für Anthropologie, 160-181.

### Periodicals

Central Africa: a Monthly Record of the Universities' Mission. London, 1883-1914.

Nachrichten aus der ostafrikanischen Mission. Berlin, 1887-1914.

### Archives Consulted

United Society for the Propagation of the Gospel. (Universities' Mission to Central Africa) London.

Bethel Mission, Bethel bei Bielefeld, Federal Republic of Germany.

Tanzania National Archives, Dar es Salaam, Tanzania.

Rhodes House, Oxford.

## ABSTRACT

Concepts of Sovereignty among the Shambaa  
and their relation to political action

D. Phil. Thesis by Steven Feierman

This thesis is a study of the political symbols and general political concepts of the Shambaa of north-eastern Tanzania, and of their relation to changing patterns of political action in the Shambaa kingdom as it existed before colonial conquest at the end of the nineteenth century. The thesis is based on research which was carried out between March 1966 and August 1968 in Tanzania, and in 1965-1966 in British and German archives.

The work is an attempt to explore the relationship between two bodies of evidence on the political organization of the Shambaa. First, there are the configurations of symbols and sets of general concepts of the Shambaa view of politics. In these, linear non-reversible time is suppressed. History is seen by the Shambaa as an alternation between strong Kings who dominated the chiefs and thereby brought fertility to the entire land, and weak Kings who competed with the chiefs, in which cases there was famine. Secondly, there is the record of political action throughout the history of the kingdom. There were frequent changes not only in the distribution of power between King and chiefs, but also in the

RH Thesis 754 9 510

potential sources of support for competing leaders. It is shown that the patterns of action which are explained by the Shambaa in terms of the general concepts did indeed change.

In Shambaa kingship the divergence between experience and an articulated system of cultural ideology was potentially great because the King was expected to provide leadership when new political or economic forces in the region impinged on the kingdom, and because the King often had the power to act in ways which were unexpected. For these reasons, the most important political concepts were general and ambiguous. They lacked precision in their classification of social groups, and in their specification of accepted behaviour.

There are two major sections of the thesis, after the statement of the problem and its setting. In the first section the kingdom is seen as a territory with a large number of commoner descent groups which were joined to one another by ties of alliance, over which there was a single governing descent group extending throughout the entire territory. There are discussions of the relationship between the commoner descent groups and the state, and of the way in which ideas of descent and alliance were applied to the regulation of power relations between King and chiefs.

The second major section deals with those symbolic configurations, administrative patterns, and political conceptions which are not stated in terms of descent or alliance. There are two major configurations of the symbols of kingship: the royal capital, which was a representation of Shambaa cosmology and of administrative arrangements, and the rites which took place at the death of one King and the accession of another. The symbols of kingship are ambivalent. They express Shambaa ideas of the King's power to bring life or death to his subjects.

A study of the symbolic relations, however, does not reveal the Shambaa view of how one achieves fertility and life rather than famine and death. This knowledge is transmitted through discourse on the nature of politics, and through popular explanations of the causes of natural or political events. The two most central concepts are kubana shi, 'to break the land,' and kuzifya shi, 'to repair the land.' It is thought that the land is broken as a result of competition between political leaders, which is usually described as 'force against force.' Competition is thought to cause famine. The land was 'repaired' when the King dominated his chiefs, so that there was no competitive action. When this happened, the Shambaa expected that the rains would come at the proper time, and the land would prosper. The legitimation of political actions with reference to the fertility of the

land is described for the whole of the past century, in order to demonstrate the way in which new patterns of action are explained in terms of the enduring categories. During this process, categories of explanation change their content.

There is a detailed statement of the contents of each chapter of the thesis on pp. 13-21.