

**FATTY ACIDS AND THE REGULATION OF PYRUVATE
DEHYDROGENASE INTERCONVERSION**

A thesis submitted to the University of Oxford in candidature for the degree of
Doctor of Philosophy

by

Melanie Ann Stewart

April 1997

Nuffield Department of Clinical Biochemistry

Radcliffe Infirmary

Woodstock Road

Oxford

OX2 6HE

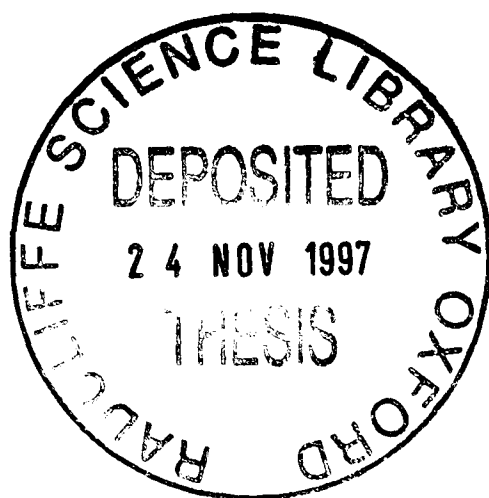

ABSTRACTFatty acids and the regulation of pyruvate dehydrogenase interconversion

This thesis presents evidence for a novel mechanism of regulation of pyruvate dehydrogenase (PDH) kinase by fatty acids and also results of a study of muscle triacylglycerol concentration. In animals regulation of PDH complex activity is central to the selection of respiratory fuels and to the conservation of glucose during carbohydrate deprivation. The principal means of regulation of PDH complex is interconversion of phosphorylated (inactive) and dephosphorylated (active) forms effected by PDH kinase and PDH phosphatase. Earlier *in vitro* studies by others had identified both shorter term (min) and longer term (hours) mechanisms of activation of PDH kinase by fatty acid.

In the present study PDH kinase activity (as measured by rates of ATP-dependent inactivation of PDH complex in extracts) was shown to be increased when rat heart mitochondria were incubated with palmitoyl-L-carnitine [PC] (and other CoA utilising respiratory substrates). The activation of PDH kinase persisted through removal of respiratory substrate following incubation with CCCP. A comparable effect of PC was also demonstrable in heart mitochondria from 48h-starved rats (*i.e.* the mechanism may be distinct from that which increases PDH kinase activity in starvation). Rates of ATP-dependent inactivation of PDH complex were also increased when extracts of rat heart mitochondria were incubated with palmitoyl-CoA (PCoA); the increase was comparable with that seen on incubation of intact mitochondria with PC. The PC effect in intact mitochondria and the PCoA effect in mitochondrial extracts may not be identical as PCoA further increased PDH kinase activity in extracts from mitochondria incubated with PC.

Rates of incorporation of ^{32}P from $[\gamma\text{-}^{32}\text{P}]\text{ATP}$ into PDH complex were unaltered by prior incubation of mitochondria with PC or by prior incubation of mitochondrial extracts with PCoA. Three lines of evidence confirmed that the effect of PC to accelerate ATP-dependent inactivation involved phosphorylation of the PDH complex (*viz*; use of a non-phosphorylating ATP analogue; use of known inhibitors of PDH kinase; and use of known activators/inhibitors of PDH phosphatase). Earlier studies had shown that phosphorylation in purified bovine and porcine PDH complexes is half site (involves only one α -chain in E1 ($\alpha_2\beta_2$)) and had suggested that phosphorylation in rat heart complex may be full site (*i.e.* involves both α -chains). The present study suggests the possibility that elevation of fatty acyl CoA under slaughter house conditions might be a determinant of half site phosphorylation.

A method was developed and evaluated for measurement of triacylglycerol in rat soleus muscle strips with the object of investigating factors that may regulate triacylglycerol synthesis in this muscle. This study was abandoned because, although the method was highly reproducible, great variation was found in the triacylglycerol concentration of individual muscles suggesting the possibility of variable contamination with small amounts of adipose tissue.

ACKNOWLEDGEMENTS

Deepest and sincerest gratitude goes to my supervisor Professor Sir Philip Randle. It has been an honour and privilege to have worked with him and alongside him in the laboratory. I have enjoyed the challenge of trying to keep up with him.

I should like to thank Alan Kerbey for his introduction to the workings of this laboratory, Pamela Stace who taught me the soleus muscle culture system, Steven Eaton for his guidance and help with the triacylglycerol experiments, Dave Priestman for his assistance and knowledge of PDH kinase, and all those who have added to my knowledge and understanding of the work presented here.

My gratitude must extend to my family especially my husband who have encouraged and supported me throughout.

To the British Diabetic Association I give thanks for its financial support.

DEDICATION

I should like to dedicate my thesis to my son who arrived, my mother who departed this life and my husband who remained supportive during the work for this thesis.

ABBREVIATIONS

AABS	p-(p-aminophenylazo) benzene sulphonic acid
Acetyl-CoA	acetyl Coenzyme A
ADP	adenosine-5'-triphosphate
AMP	adenosine-5'-monophosphate
AMP-PNP	adenosine 5'-[$\beta\gamma$ -imido] triphosphate
ATP	adenosine-5'-triphosphate
BSA	bovine serum albumin
BSA-ffa	bovine serum albumin free of fatty acids
°C	degrees centigrade
cAMP	adenosine 3',5'-monophosphate
CCCP	carbonyl cyanide <i>m</i> -chlorophenylhydrazone
CoA	Coenzyme A
cpm	radioactive counts per minute
<i>C. viscosum</i>	<i>Chromobacterium viscosum</i> lipase
Da	Daltons
dpm	radioactive disintegrations per minute
DTNB	5,5'-dithiobis (2-dinitrobenzoic acid)
DTT	DL-dithiothreitol
EDTA	ethylene diamine tetracetic acid
EGTA	ethylene-bis (oxyethylenenitrile) tetracetate
FFA	free fatty acids
g	grammes
<i>g</i>	gravitational force
GLUT 4	glucose transporter type number 4
h	hour
k	pseudo first order rate constant
KHB	Krebs-Henseleit bicarbonate buffer
K_d	dissociation constant
K_i	inhibitory constant
K_m	Michaelis-Menton constant
l	litre
LDH	lactate dehydrogenase
M	molar
MBq	megabecquerels
mg	milligramme
min	minute
ml	millilitre
mM	millimolar

M_r	molecular weight
mU	milliunit
μ l	microlitre
μ M	micromolar
NAD ⁺	nicotinamide adenine dinucleotide (oxidised)
NADH	nicotinamide adenine dinucleotide (reduced)
P	probability of an event being due to chance alone
PABF	pyruvate dehydrogenase assay buffer with fluoride
PDH	pyruvate dehydrogenase
PFK1	phosphofructo 1-kinase
pH	$-\log_{10}[\text{H}^+]$
P_i	inorganic orthophosphate
PP_i	pyrophosphate
<i>R. arrhizus</i>	<i>Rhizopus arrhizus</i> lipase
s	second
SEM	standard error of the mean
TCA	trichloroacetic acid
TEA	triethanolamine
TLC	thin layer chromatography
TLCK	tosyl lysine chloromethyl ketone
TPP	thiamine pyrophosphate
Tris	tris (hydroxymethyl) aminomethane
U	unit
V_{max}	maximal catalytic activity
(v/v)	volume for volume
(w/v)	weight in the volume
wt	weight

CONTENTS

	Page	
Chapter 1	General introduction	1.1-1.31
Chapter 2	Long term regulation of triacylglycerol metabolism in rat soleus muscle, <i>in vitro</i>	2.1-2.47
Chapter 3	Effect of palmitoyl carnitine and of other respiratory substrates on activity of pyruvate dehydrogenase kinase in rat heart mitochondria	3.1-3.30
Chapter 4	Effect of palmitoyl-CoA on activity of pyruvate dehydrogenase kinase in rat heart mitochondrial extracts	4.1-4.17
Chapter 5	Effect of palmitoyl carnitine on incorporation of ^{32}P from $[\gamma\text{-}^{32}\text{P}]\text{ATP}$ into PDH complex in extracts of rat heart mitochondria	5.1-5.26
Chapter 6	General Conclusions	6.1-6.4
Appendix		
Bibliography		

Chapter 1

General Introduction

INDEX

	Page
1 Fatty acids and the regulation of pyruvate dehydrogenase interconversion	1.3
2 Background	1.5
3 Structure, reactions and mechanism of reaction of the PDH complex	1.11
<i>Structure of the PDH complex</i>	1.11
<i>Reactions and mechanism of reactions catalysed by the PDH complex</i>	1.13
4 Regulation of PDH complex activity	1.14
<i>Allosteric inhibition</i>	1.14
<i>End product inhibition</i>	1.15
<i>Reversible phosphorylation</i>	1.16
5 PDH phosphatase	1.19
<i>Structure of the PDH phosphatases</i>	1.20
<i>Regulation of PDH phosphatase activity</i>	1.20
6 PDH kinase	1.24
<i>Structure of PDH kinase</i>	1.24
<i>Regulation of PDH kinase activity</i>	1.26
7 Outline of the dissertation	1.30

is small except in tissues synthesising fatty acids (Randle *et al.*, 1964; Glock and McLean, 1954; Green and Landau, 1965).

It was known that during endocrine disorders and nutritional variation such as starvation, carbohydrate deprivation, high fat diets and diabetes, where glucose utilisation was defective, that plasma concentrations of free fatty acids (FFA) and ketone bodies were substantially greater than normal. Drury and Wick, in 1953, observed that in rabbits injected with 3-hydroxybutyrate or acetate, conversion of [^{14}C]glucose into $^{14}\text{CO}_2$ decreased. This interesting observation led to the demonstration that glucose metabolism could be inhibited *in vitro* by perfusion of isolated hearts or incubation of isolated diaphragm muscle with fatty acids and ketone bodies. It also prompted further work in Professor Randle's and other laboratories to investigate the molecular mechanisms of fuel selection for respiration.

The results of these subsequent experiments demonstrated that glucose uptake, glucose phosphorylation and pyruvate oxidation were decreased in heart and skeletal muscle by starvation, alloxan-diabetes and in normal muscle by fatty acids and ketone bodies *in vitro*. Glucose uptake was greater in perfused isolated hearts from fed rats than with hearts of fasted rats or with alloxan-diabetic rats both in the presence or absence of insulin (Randle *et al.*, 1966). Glucose uptake was also inhibited by perfusion of hearts with fatty acids, such as palmitate, octanoate and butyrate, and the ketone bodies both in the presence and absence of insulin (Williamson and Krebs, 1961, Newsholme *et al.*, 1962). (It is now known that glucose uptake may be limited in tissues other than liver by the action of the appropriate glucose transporter in insulin sensitive cells (muscles, adipocytes). The membrane concentration of the glucose transporter GLUT4 is increased by insulin.) The concentration of glucose and fructose 6-phosphate was increased and that of fructose 1:6 bisphosphate was decreased in muscle by starvation and alloxan-diabetes (Newsholme and Randle, 1961; Regen *et al.*, 1961) and by fatty acids and ketone bodies in perfused hearts from normal fed rats (Newsholme *et al.*, 1962; Newsholme and Randle, 1964), indicating that phosphofructokinase had been inhibited. As hexokinase in muscle was found to be inhibited by glucose 6-phosphate a decrease in hexokinase activity could also inhibit glucose uptake provided that glucose uptake was not rate limiting.

the oxidation of ketone bodies.

Blood glucose homeostasis is carefully controlled by hormones such as insulin and glucagon. There is a further means of conserving glucose during conditions such as carbohydrate deprivation where, in other tissues such as skeletal muscle and heart, there is a switch from glucose as the fuel for generating ATP to fatty acids and ketone bodies. As skeletal muscle is the major site for glucose disposal (DeFronzo, 1988) the switch to fatty acids or ketone bodies for oxidation in this tissue serves as an important means of regulating blood glucose concentrations. Glucose cannot be resynthesised from acetyl-CoA by most animals as they lack the pathway of resynthesis. Therefore, oxidation of glucose in these animals is irreversible. However, Cori and Cori (1931) showed that lactate and pyruvate, produced by extrahepatic tissues and released into the blood stream, could be reconverted to glucose in the liver (gluconeogenesis). In these tissues, lactate and pyruvate production exceeds pyruvate oxidation. The Cori cycle is given in Figure 1. An example of how blood glucose homeostasis is maintained is that occurring in man, after 28-42 days of starvation even though liver glycogen reserves are largely depleted within 24 hours, the plasma glucose concentration may decrease by only approx. 25 per cent.

Other impositions on the system of fuel metabolism include the intermittent nature of dietary supply of fuels for respiration and limited amount of whole body fuel reserves. Glucose derived from the diet is not continuously released into the blood stream. The composition of the average Western diet is 40-50 per cent glucose, 33-43 per cent fat and 13-17 per cent protein. Fuels from the gut are taken up and stored mainly as triacylglycerol and glycogen. There are no reserves as such of protein and the contribution of protein to energy production is normally small and relatively constant. The quantities of fuels stored and the estimated periods for which fuel stores would provide energy during starvation (sedentary), walking and marathon running, are given in Table 1. The table shows that as a proportion of the total fuels available, glucose and the store of glucose are small (<2 per cent), and that most energy is stored as triacylglycerol (>68 per cent, but this figure depends upon the degree of adiposity and the extent to which protein stores are utilised).

Figure 1 The Cori cycle (Glucose re-cycling)

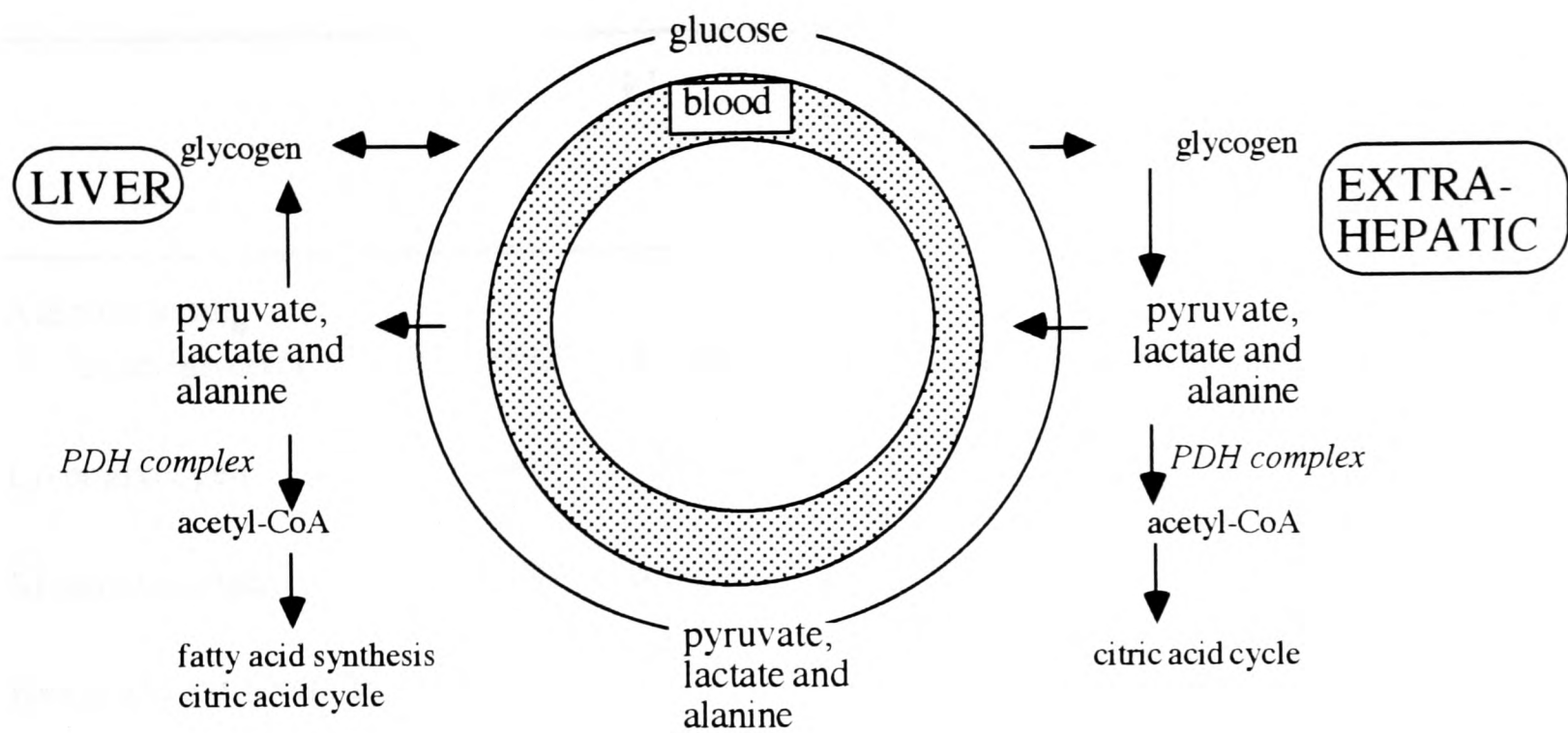

Arrows represent conversion of body glucose by re-cycling. Irretrievable loss of glucose is occasioned by the operation of the PDH complex reaction *via* glucose oxidation and fatty acid synthesis.

Table 1 Fuel reserves in an average man

Tissue fuel stores	Approximate total fuel reserve		Estimated period for which fuel store would provide energy**		
	g	kJ	Days of starvation†	Days of walking*	Minutes of marathon running§
Adipose tissue triacylglycerol	9000	337 000	34	10.8	4 018
Liver glycogen	90	1500	0.15	0.05	18
Muscle glycogen	350	6 000	0.6	0.2	71
Blood and extracellular glucose	20	320	0.03	0.01	4
Body protein	8 800	150 000	15	4.8	1 800

Table is reproduced from Newsholme and Leech (1983). The data above are based on the following assumptions:

- 1) that the man is normal (*i.e.* not diabetic) weighing 65kg of which 9kg is triacylglycerol,
- 2) ** that the time indicated is the length of time to utilise that particular fuel if it were the only fuel available, and
- 2) about energy expenditure are † during starvation is 10 050kJ/day, * during walking (4miles/h) is 131 248kJ/day, § during running is 84kJ/min.

In skeletal muscle and other tissues not solely dependent on glucose for energy production, the contribution of fatty acids to energy expenditure increases with fasting, high fat diets, exercise and diabetes. After an overnight fast, the oxidation of fatty acids increases and accounts for 70 per cent of the oxygen consumption, and carbohydrate decreases to 12 per cent. During prolonged starvation the contribution of glucose may decrease to less than 5 per cent (Cahill and Owen, 1968; Randle *et al.*, 1978). In uncontrolled diabetes, the oxidation of glucose following an oral glucose load is decreased from 40 per cent to 13 per cent with insulin-dependent diabetics (Meyer *et al.*, 1980). With moderate exercise, the oxidation of glucose is initially enhanced; but after 1 hour, or with more severe exercise, the contribution of glucose to energy production decreases just as it does with fat feeding or diabetes (Wahren *et al.*, 1978; Felig and Kiovisto 1979; Lefebvre 1985). However, the increase in the rate of glucose oxidation achieved by exercise in uncontrolled diabetics is substantially less than that in non-diabetics (Krzentowski *et al.*, 1981). Intravenous administration of triacylglycerol (intralipid) accelerates fatty acid oxidation, and, in man, glucose oxidation is decreased by 30 per cent (Vouillmoz *et al.*, 1984).

2 Background

Earlier experiments in Professor Randle's laboratory, in the 1960's, identified key reactions which regulate glucose metabolism. In muscle tissue the key points are in glucose uptake, flux through glycolysis and pyruvate oxidation and the reactions are glucose transport and the activities of hexokinase, 6-phosphofructo kinase and the PDH complex. In conditions such as starvation, feeding high fat diets or diabetes, glucose metabolism is decreased by decreasing the flow of glucose through these key points. Exercise has the reverse effect and flow of glucose through these points is increased. (For reviews see Randle *et al.*, 1966 and Randle *et al.*, 1988). Glucose may also be taken up and stored as glycogen in, predominantly, muscle and liver. The contribution of the pentose phosphate pathway to the oxidation of glucose

is small except in tissues synthesising fatty acids (Randle *et al.*, 1964; Glock and McLean, 1954; Green and Landau, 1965).

It was known that during endocrine disorders and nutritional variation such as starvation, carbohydrate deprivation, high fat diets and diabetes, where glucose utilisation was defective, that plasma concentrations of free fatty acids (FFA) and ketone bodies were substantially greater than normal. Drury and Wick, in 1953, observed that in rabbits injected with 3-hydroxybutyrate or acetate, conversion of [^{14}C]glucose into $^{14}\text{CO}_2$ decreased. This interesting observation led to the demonstration that glucose metabolism could be inhibited *in vitro* by perfusion of isolated hearts or incubation of isolated diaphragm muscle with fatty acids and ketone bodies. It also prompted further work in Professor Randle's and other laboratories to investigate the molecular mechanisms of fuel selection for respiration.

The results of these subsequent experiments demonstrated that glucose uptake, glucose phosphorylation and pyruvate oxidation were decreased in heart and skeletal muscle by starvation, alloxan-diabetes and in normal muscle by fatty acids and ketone bodies *in vitro*. Glucose uptake was greater in perfused isolated hearts from fed rats than with hearts of fasted rats or with alloxan-diabetic rats both in the presence or absence of insulin (Randle *et al.*, 1966). Glucose uptake was also inhibited by perfusion of hearts with fatty acids, such as palmitate, octanoate and butyrate, and the ketone bodies both in the presence and absence of insulin (Williamson and Krebs, 1961, Newsholme *et al.*, 1962). (It is now known that glucose uptake may be limited in tissues other than liver by the action of the appropriate glucose transporter in insulin sensitive cells (muscles, adipocytes). The membrane concentration of the glucose transporter GLUT4 is increased by insulin.) The concentration of glucose and fructose 6-phosphate was increased and that of fructose 1:6 bisphosphate was decreased in muscle by starvation and alloxan-diabetes (Newsholme and Randle, 1961; Regen *et al.*, 1961) and by fatty acids and ketone bodies in perfused hearts from normal fed rats (Newsholme *et al.*, 1962; Newsholme and Randle, 1964), indicating that phosphofructokinase had been inhibited. As hexokinase in muscle was found to be inhibited by glucose 6-phosphate a decrease in hexokinase activity could also inhibit glucose uptake provided that glucose uptake was not rate limiting.

Accumulation of glucose 6-phosphate is generally secondary to inhibition of phosphofructo 1-kinase, as the glucose phosphate isomerase reaction is at near equilibrium (Randle and Pogson, 1965). Phosphofructo 1-kinase was also inhibited in perfused hearts by starvation and alloxan-diabetes (Newsholme *et al.*, 1962; Newsholme and Randle, 1964) and by perfusion of hearts from normal fed rats with fatty acids and ketone bodies. Similarly, pyruvate oxidation was decreased with perfused rat hearts and hemidiaphragms by starvation, diabetes and perfusion or incubation with fatty acids and ketone bodies (Garland *et al.*, 1962, 1963).

Until then, the prevailing view of fuel selection was that defective glucose utilisation resulted in enhanced lipid oxidation. But the work by a number of researchers (*e.g.* Vaughan, 1961; Jungas and Ball, 1963; summarised in Randle *et al.*, 1963) and the discovery that in adipose tissue lipolysis is a glucose-independent process modulated by hormones such as epinephrine and insulin, led to the idea that the high plasma fatty acid concentrations found in conditions such as starvation, diabetes, and low carbohydrate diets were responsible for impaired glucose uptake and oxidation rather than being a passive consequence. That the mechanism took the form of a regulatory cycle, the glucose-fatty acid cycle, was first proposed by Randle *et al.* in 1963.

Furthermore it was found that with preparations of porcine heart PDH complex that the complex was directly inhibited by acetyl-CoA and that the inhibition was competitive with CoA (Garland and Randle, 1964a). The concentrations of acetyl-CoA were also increased in hearts by diabetes or by perfusion of hearts from normal rats with acetate, β -hydroxybutyrate and butyrate whilst the total concentrations of CoA remained unchanged. These results and the control of phosphofructokinase by citrate, which was elevated by fatty acid oxidation, were thought to provide the means whereby glucose utilisation is decreased by an increase in fatty acid oxidation.

Further experiments showed that an important source of fatty acids for respiration was the muscle tissue itself. Intracellular concentrations of fatty acyl-CoA, free fatty acids and glycerol output, measured *in vitro*, were increased in hearts and diaphragms from starved and diabetic rats compared with that from normal fed rats, in spite of the fact that the tissues had been removed from the influence of circulating fatty acids. These results indicated that increased intracellular triacylglycerol breakdown may increase the provision of fatty acids for respiration in

these tissues *in vitro* and possibly *in vivo* (Garland and Randle, 1964b; Denton and Randle, 1967).

In summary, the essential components of the glucose-fatty acid cycle are: a) the relationship between glucose and fatty acid metabolism is reciprocal and not dependent; b) *in vivo*, oxidation of FFA and ketone bodies released into the circulation in diabetes and starvation may inhibit uptake and oxidation of glucose in muscle; c) *in vitro*, the oxidation of FFA released from muscle triacylglycerol may have similar effects; d) these effects of FFA and ketone body oxidation are mediated by inhibition of PDH complex, phosphofructo 1-kinase and hexokinase; e) the central mechanism is an increase in the mitochondrial ratio of [acetyl-CoA]/[CoA] which inhibits the PDH complex directly, and which indirectly leads to inhibition of phosphofructo 1-kinase by citrate and of hexokinase by glucose 6-phosphate; f) and also the effect of physiological concentrations of insulin to activate glucose transport in heart muscle is inhibited by FFA and ketone bodies.

Since the initial proposal other points in the regulation and coordination of the metabolism of glucose and fatty acids have been found. These include the mechanism of citrate accumulation by unspanning of the citrate cycle (Randle *et al.*, 1970) which is given below and the discovery of fructose 2,6 bisphosphate and the bifunctional phosphofructo-2-kinase/fructose 2,6 bisphosphatase (Hers and Van Schaftingen, 1982). Other studies have shown that fatty acid oxidation stimulates gluconeogenesis and inhibits glucose uptake and glycolysis, in liver (Struck *et al.*, 1966; Hue *et al.*, 1988; Berry *et al.*, 1993). Restoration of normal rates of glucose uptake and oxidation in hearts of diabetic rats can be achieved by inhibition of fatty acid oxidation with 2-bromostearate (Burges *et al.*, 1969; Randle, 1969). Important extensions to non-muscle tissues were provided by the demonstrations that ketone bodies may inhibit glucose oxidation in brain (Owen *et al.*, 1967; Itoh and Quastel, 1970). The mechanisms of decreased glucose utilisation in muscle are summarised in Figure 2.

Unspanning of the citric acid cycle. In muscle, during the onset of the effects of an increase in fatty acid utilisation, the ratio of [acetyl-CoA]/[CoA] increases and directly inhibits the PDH complex (Garland and Randle, 1964a), and thus pyruvate oxidation decreases. Glycolysis

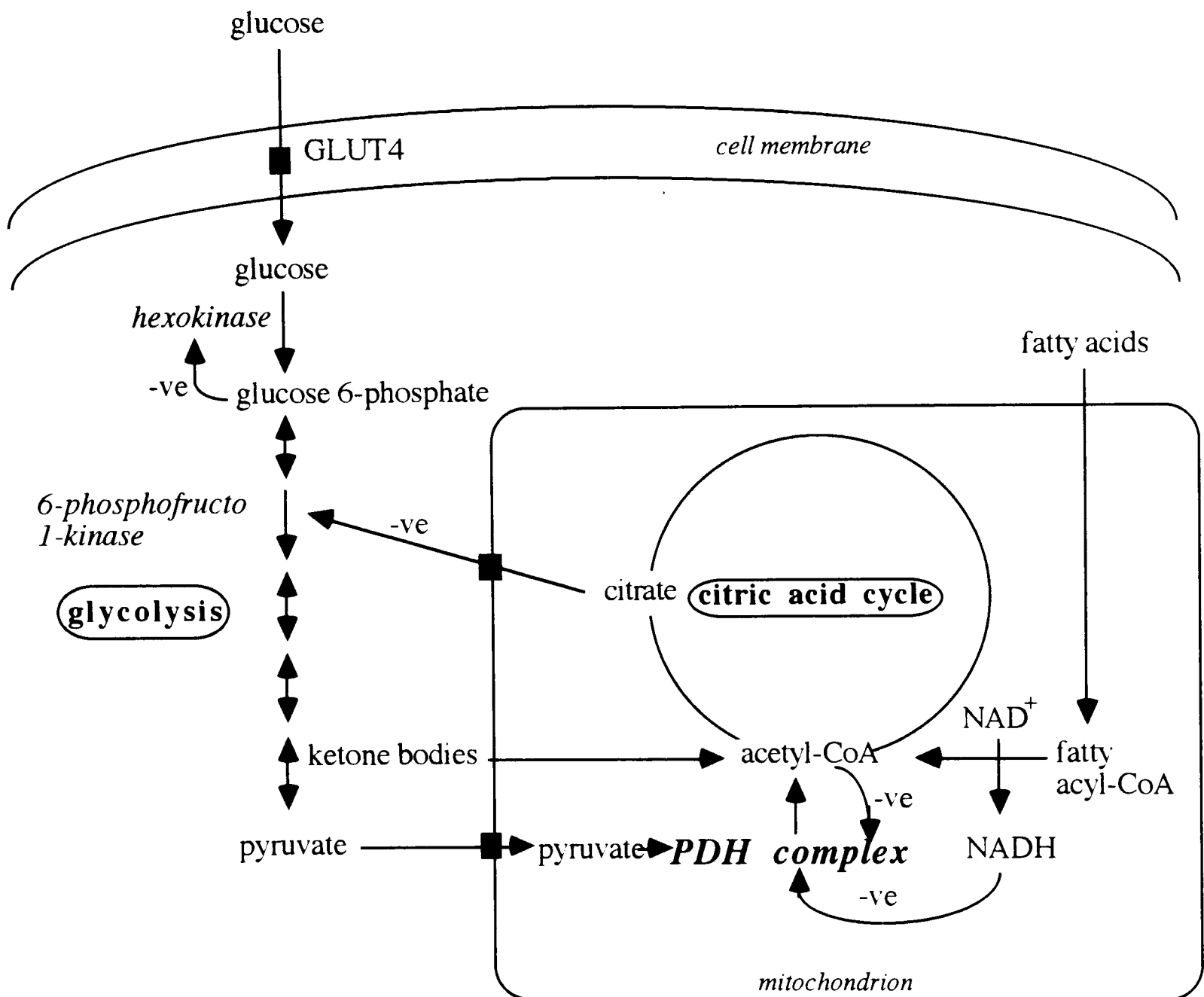
Figure 2 The coordinated control of glycolysis by fatty acid oxidation

The products of fatty acid oxidation have inhibitory effects on the reactions involved in glycolysis and glucose oxidation. Arrows represent steps in the pathway of glycolysis, and broken circle represents the reactions of the citric acid cycle.

continues at the same rate initially, but is decreased directly by increasing concentrations of cytosolic citrate and inhibition of phosphofructo 1-kinase (PFK1), and indirectly through inhibition of phosphofructo 2-kinase by citrate with concomitant decrease in fructose 2,6-bisphosphate and control of PFK1 by fructose 2,6-bisphosphate. In the mitochondrion, the oxaloacetate required for citrate accumulation may be accelerated by coupled transamination of aspartate with pyruvate and aspartate with α -ketoglutarate or by pyruvate carboxylase where present. It then leaves the mitochondrion, *via* the citrate-dicarboxylate exchanger, thus increasing the cytosolic concentration. The mechanism of citrate accumulation is summarised in Figure 3 (Randle *et al.*, 1970).

Phosphofructo 1-kinase. The mechanisms of regulation of PFK1 activity are: (i) inhibition by ATP and citrate, and activation by 5'AMP, ADP and P_i (in heart extracts, Passonneau and Lowry, 1962; Garland *et al.*, 1963) and (ii) allosteric activation by fructose 2,6-bisphosphate produced in response to switching the bifunctional enzyme phosphofructo 2-kinase/fructose 2,6-bisphosphatase (PFK2-F26BP) to the kinase mode (Van Schaftingen and Hers, 1980; Uyeda *et al.*, 1981). (In heart muscle the main interest is the stimulation of glycolysis by exercise and by the lack of oxygen. Glucose transport and glycogenolysis is increased (Ca^{2+} effector of phosphorylase) and phosphofructo 1-kinase is activated by increases in the concentration of fructose 2,6-bisphosphate (Nrabayashi *et al.*, 1985).) In liver, this mechanism is important in the coordination of glycolysis and gluconeogenesis.

Subsequent experiments led to doubts about the applicability of the cycle in skeletal muscle (for particular references see review by Randle *et al.*, 1988), but these doubts were dispelled when ketone bodies were found to inhibit glucose utilisation by soleus muscle (Cuendent *et al.*, 1975). Evidence for the cycle is now unequivocal. In man *in vivo* under conditions of a hyperinsulinaemic glucose clamp, when plasma fatty acid levels are increased by concomitant infusion of triacylglycerol emulsion, whole body glucose disposal was decreased (Thiebaud *et al.*, 1982; Ferrannini *et al.*, 1983; Lee *et al.*, 1988; Johnson *et al.*, 1992). Plasma fatty acids were raised (*e.g.* infusion of Intralipid) and glucose metabolism measured *in vitro*, in skeletal muscle, was found to be decreased (Grundleger and Thenen, 1982). Similar

Figure 3 Unspanning the citrate cycle. Mechanism of increase in cytosolic citrate concentration, mediated by the oxidation of fatty acid and ketone bodies, and of starvation and diabetes, in rat muscle

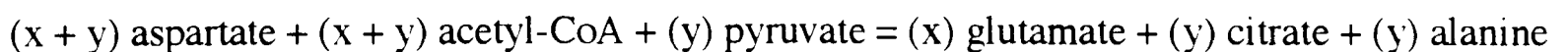
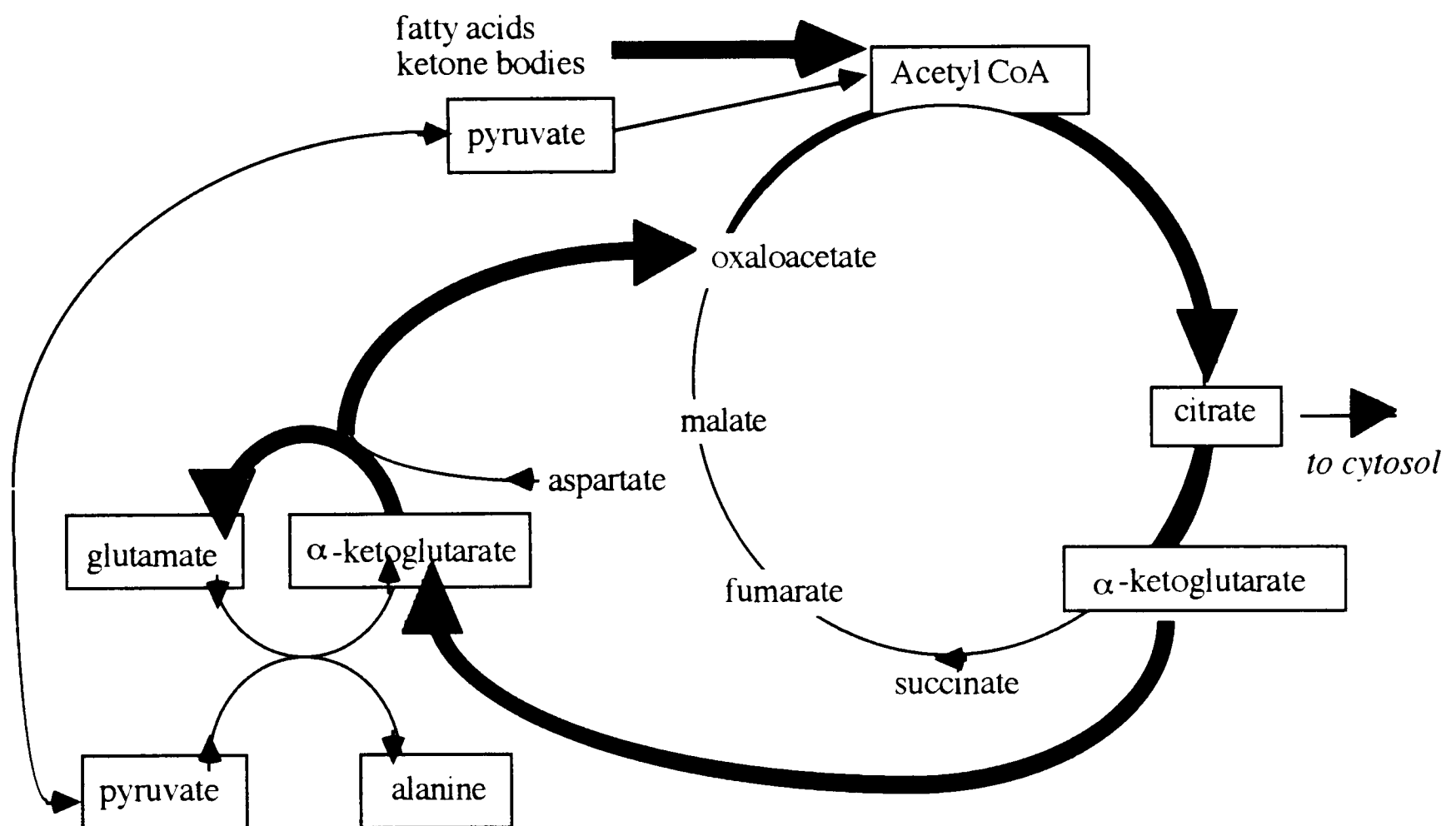

Mechanism of increase in cytosolic citrate concentration, mediated by the oxidation of fatty acid and ketone bodies, and of starvation and diabetes, in rat muscle (unspanning of the citrate cycle). Bold arrows indicate increased fluxes during the transient period from glucose to acetate as the metabolic fuel. The oxaloacetate required for citrate accumulation is derived from coupled transamination of aspartate with pyruvate. The oxaloacetate required for glutamate accumulation is derived from transamination of aspartate with α -ketoglutarate (Randle *et al.*, 1970). Some oxaloacetate is formed by carboxylation of pyruvate. This schematic representation is taken from a review by Randle *et al.* (1988).

results were found with Positron Emission Tomography in heart and in hind limb and fore limb skeletal muscles (Nuutila *et al.*, 1992) and forearm and hind limb perfusion studies (Piatti *et al.*, 1991; Walker *et al.*, 1990; Yki-Jarvinen *et al.*, 1991). Relevant recent reviews include Randle (1986), Randle, *et al.* (1988) and Randle (1994).

The inhibitory effects of fatty acid and ketone body oxidation on glucose degradation are most severe at the level of the PDH complex. This was recognised during the work that led to the original proposal for the glucose-fatty acid cycle. Current evidence indicates that the activity of the PDH complex is a major determinant of the rate of glucose oxidation *in vivo*. In normal people and experimental animals, measurement of the arterio-venous differences of pyruvate (and lactate and alanine) show that glycolytic flux exceeds pyruvate oxidation (McAllister *et al.*, 1973; Felig and Koivisto, 1979). In conditions where glucose oxidation is decreased (fat feeding, starvation or diabetes), uptake and oxidation of pyruvate by tissues is decreased, but plasma concentrations of pyruvate, lactate and alanine are not decreased. This suggests that the plasma concentration of fatty acids does not regulate the rate of uptake and oxidation of pyruvate, and irrespective of the rate of glycolysis, decreased uptake and oxidation of pyruvate is accounted for by the decrease in the activity of the PDH complex.

The essential role of the activity of the PDH complex in fuel selection (the activity being regulated by interconversion between phosphorylated and dephosphorylated forms) has been demonstrated by the use of inhibitors of PDH kinase, such as dichloroacetate. Administration of dichloroacetate, *in vivo*, is associated with hypoglycaemia in human diabetics (Wells *et al.*, 1980); an increase in the respiratory quotient in fasting or diabetic rats (Lorini and Ciman, 1962; Whitehouse *et al.*, 1974); decreases in blood lactate, pyruvate and alanine (McAllister *et al.*, 1973; Randle *et al.*, 1978); an increase in myocardial extractions of glucose, lactate and pyruvate (McAllister *et al.*, 1973); and an increase in the PDH complex activity by up to 70-fold (Whitehouse and Randle, 1973).

There follows an account of what is known about the PDH complex, the mechanisms of its regulation, and mechanisms of the regulation of the interconverting enzymes PDH kinase and PDH phosphatase.

3 Structure, reactions and mechanism of reaction of the PDH complex

Structure of the PDH complex

PDH complex has a molecular weight approaching 10^7 - reported values are approx. 7×10^6 Da in bovine kidney, 8.5×10^6 Da in bovine heart and 12×10^6 Da in porcine heart (reviewed in Reed *et al.*, 1980; Randle, 1983). The specific activity of purified bovine complex was reported as 16.8U/mg of protein by Linn *et al.* (1972).

PDH complex consists of 3 separate catalytic components. These are pyruvate dehydrogenase (E1) (which will be referred to as pyruvate decarboxylase), dihydrolipoyl acetyltransferase (E2) and dihydrolipoamide dehydrogenase (E3). Resolution of the holocomplex from bovine kidney or heart, into its components by SDS PAGE or gel filtration at alkaline pH and high ionic strength yields 4 bands. For porcine heart complex, with their respective subunit molecular weights, these are 1) E1 α M_r 40 600 and 2) E1 β M_r 31 500, 3) E2 M_r 76 100, and 4) E3 M_r 58 200. A fifth band named initially protein-X and now identified as E3 binding protein (E3BP) (M_r 52 000) was detected on SDS PAGE in Tris buffer (Stanley and Perham, 1980; Kerbey and Randle, 1985; Rahmatullah and Roche, 1985). The molecular weight of E2 has been shown to be 52 000 using sedimentation equilibrium (Barrera *et al.*, 1972) and the difference may be due to the extended configuration (because of the covalently bound lipoyl moiety) of this component. Exact molecular weights have been deduced from the primary structure of the component subunits. The component enzymes of bovine and porcine PDH complex, PDH phosphatase and PDH kinase are given in Table 2.

The secondary structure is made of polymers of subunits in each component. Each E1 consists of 2 α and 2 β subunits and each tetramer binds to one molecule of TPP. The binding requires Mg^{2+} and is probably *via* a histidine residue on one of the α subunits (Sanadi, 1963; Wieland *et al.*, 1969; Walsh *et al.*, 1976; Severin and Feigina, 1977). E3 consists of a dimer of a single subunit and two FAD molecules. Little is known about the structure of E3. There are common sequence motifs detected between E1 α -chains of all α -keto acid dehydrogenase complexes, and those predicted to be involved with TPP binding (Hawkins *et al.*, 1989).

Table 2 Component enzymes of bovine and porcine PDH complex, PDH phosphatase and PDH kinase

Enzyme	M_r	Subunits per mol of complex
Native complex	8 500 000	
E1 = pyruvate dehydrogenase	156 000	30-60
α -subunit	40 600 - 42 000	60-120
β -subunit	35 100 - 36 000	60-120
E2 = dihydrolipoate acetyltransferase		
bovine	3 100 000	
pig	1 800 000	
subunit	52 000 - 76 100	60
E3 = dihydrolipoyl dehydrogenase	110 000	12
subunit	55 000 - 58 200	24
E3BP	52 000	12
PDH kinase	93 000	5
α -subunit	48 000	5
β -subunit	45 000	5
PDH phosphatase	147 000	
α -subunit	97 000	
β -subunit	50 000	

Data is taken from Reed and Oliver, (1968); Reed *et al.* (1980); Linn *et al.*, (1972); Barrera *et al.*, (1972); Hayakawa *et al.*, (1978); Sugden and Randle, (1978); Stepp *et al.*, (1983) and Teague *et al.*, (1982). M_r based on SDS-PAGE in phosphate buffer, except for E3BP, which is based on SDS-PAGE in Tris-glycine buffer and E2 subunit based on sedimentation equilibrium.

Chemical modification experiments have identified a cysteine residue in the bovine E1 α -chain (Ali *et al.*, 1993) and a tryptophan residue in the human E1 β chain (Ali *et al.*, 1995) that are associated with TPP binding.

The secondary and tertiary structure of the E2 component is four globular domains consisting of a lipoyl domain attached to the terminal NH_2 of lysine (L1), an inner lipoyl domain (L2), a peripheral binding domain for binding of E1 and possibly E3 *via* linkage with E3BP, and a core forming transacetylase inner domain at the COOH terminal (Patel and Roche, 1990; Reed and Hackert, 1990; Perham, 1991) (Figure 4). There are two important features of the structure of each E2 component. Firstly, the domain-linker regions that give the structure of E2 and, therefore, the holocomplex flexibility (Perham, 1991). These regions are sensitive to proteolysis a fact that has aided their study. Secondly, the lipoyl-domains have lipoic acid attached. These lipoyl residues transfer the acetyl and H^+ groups sequentially from substrates to products. The two lipoyl binding domains are bound with lipoic acid by catalysis with lipoate protein ligase (Brookfield *et al.*, 1991). In prokaryotes, lipoylation of the lipoyl domain of E2 shows that its conformation is unaltered by lipoyl binding (Dardel *et al.*, 1990). The amino acid sequences of lipoyl domains from many sources are highly conserved (Dardel *et al.*, 1993). Lipoylation by lipoate protein ligase is highly specific for the N^6 -amino group of the lysine residue at the tip of the β -turn in the lipoyl domains. The E1 component requires the presence of the entire lipoyl domain for the reductive acetylation of the pendant lipoyl group, despite the fact that the dithiolane ring, at the end of the swinging arm, is approx. 1.4nm from the backbone of the E2 polypeptide chain. E1 cannot use free lipoic acid, lipoamide or a lipoylated decapeptide that has an amino acid sequence identical to the surrounding lipoyl-lysine residue of the substrate (Graham *et al.*, 1989).

The quaternary structure or the complete three dimensional structure has not been fully determined probably because of its structural complexity and size, and its inherent conformational flexibility. Intact complexes have resisted attempts at crystallisation. The structure has been studied by isolating components and subassemblies. Based upon electron micrographs of the complex of the acetyltransferase core made up of 60-mer multiple copies of

Figure 4 Secondary and tertiary structures of E2 and E3 components of the PDH complex

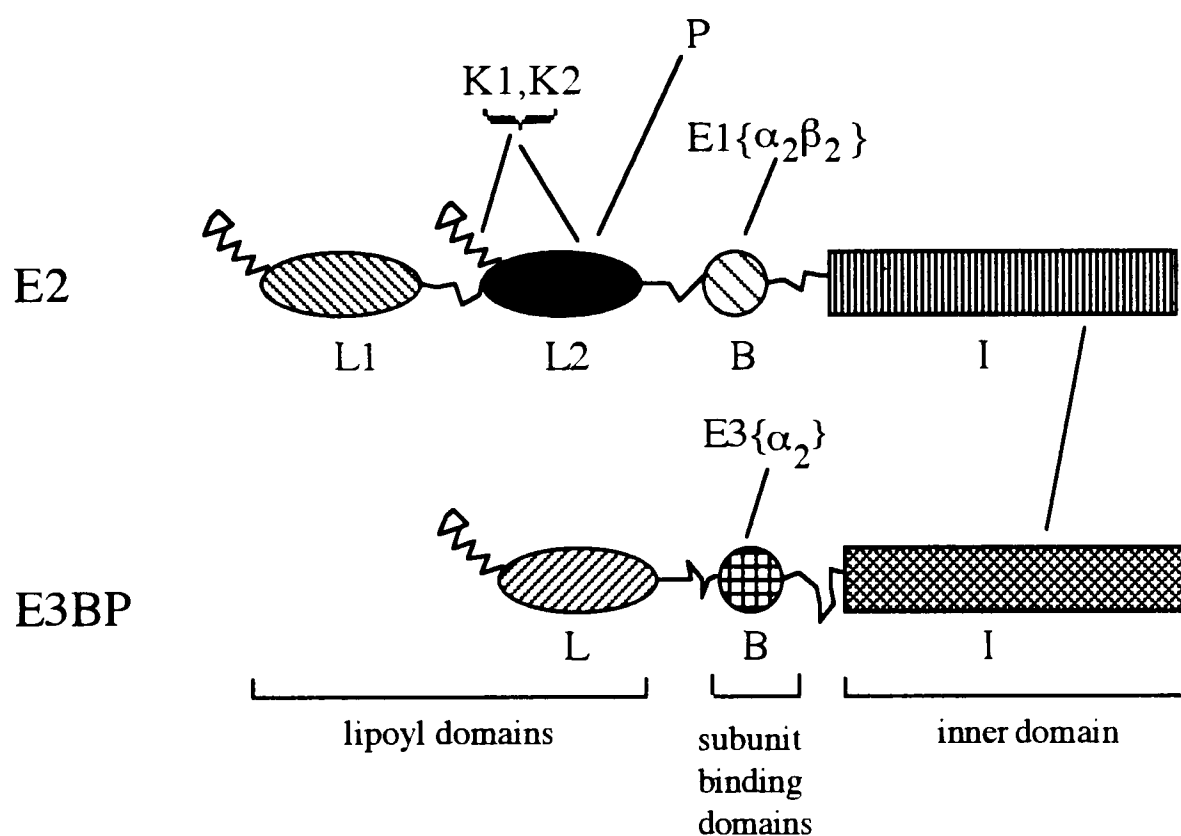

Domain structure of E2 and E3BP and binding interactions of their domains and E2's prosthetic groups with each other and other components of the PDH complex. The globular domains of E2 and E3BP are shown with their connecting linker or hinge regions represented as wavy lines. The distinct, but related lipoyl domains, are designated L1 and L2 in E2, and L in E3BP, and are shown with a representation of attached lipoyl groups. The interactions between components and specific domains of E2 are indicated with diagonal lines. For the components required for the PDH complex reaction, associations are shown between the inner domain, I, of E2 and of E3BP (Rahmatullah *et al.*, 1989a), between β -subunit of E1 and the component binding domain, B, of E2 (Rahmatullah *et al.*, 1989b, 1990), between the E3 and E3BP (Rahmatullah *et al.*, 1989b; Powers-Greenwood *et al.*, 1989) by the B domain of E3BP (Lawson *et al.*, 1991). PDH kinase (K1 and K2 isoforms) bind to the lipoyl domain region of E2 by and in interaction with the L2 domain that also requires the lipoyl prosthetic group (Rahmatullah *et al.*, 1990; Li *et al.*, 1992; Ono *et al.*, 1993; Liu *et al.*, 1995); and the PDH phosphatase (P) also interacts with the L2 domain of E2.

the E2 component, from porcine heart and bovine kidney, its appearance is that of a pentagonal dodecahedron with 532 symmetry (Reed and Hackert, 1990; Perham, 1991; Reed and Oliver, 1968; Hayawaka *et al.*, 1969). (The point symmetry of E2 component in *Escherichia coli* is octahedral (432) symmetry consisting of 24 subunits arranged.) (See Figure 5) The E1 component binds tightly to the surface of the core of the peripheral subunit binding domain of the E2 chain. The E3 binding domain is located in E3BP (Patel and Roche, 1990; Reed and Hackert, 1990). The lipoyl and peripheral subunit binding domains extend outwards from the inner E2 core, interdigitating between the E1 and E3 components (Reed and Hackert, 1990; Perham, 1991; Roche *et al.*, 1993). According to Reed *et al.* (1980) for bovine complexes this structure contains 30 E1 tetramers and Sugden and Randle (1978) and Kerbey and Randle (1985) report the number to be 60 per porcine heart complex. Estimates suggest that there are about 6 E3 components attached to each E2 core and no additional binding is possible (Wu and Reed, 1984). Each dimer is envisaged to span between two of the 12 adjacent faces of the core. The dissociation constant is approx. 3nM . E3BP is tightly bound to the E2 core and co-purifies with it (DeMarcucci and Lindsay, 1985; Rahmatullah *et al.*, 1986). There are an estimated 12 such components attached to each core (Jilka *et al.*, 1986).

The function of E3BP is to bind E3 close to the core. It contains a lipoyl domain and a peripheral subunit-binding domain. E3BP is required for the proper association of the E3 component of the PDH complex with the E2 core. One molecule of E3BP carries one dimer of E3 and is capable of binding to each of the 12 faces of the pentagonal dodecahedron E2 core (Maeng *et al.*, 1994). The lipoyl group may participate in catalytic activity.

Reactions and mechanism of reactions catalysed by the PDH complex

The reactions catalysed by the PDH complex have been shown to involve the three different enzymes acting in sequence (Gunsalus, 1954; Reed, 1960; Ullrich and Mannschreck, 1967; Hayakawa *et al.*, 1969; Linn *et al.*, 1972; Koike *et al.*, 1963; Massey, 1963; Walsh *et al.*, 1976). In the PDH complex reaction it is thought to be that the initial decarboxylation by E1 and the final reoxidation of the dihydrolipoyl group by E3 take place outside the core, whereas

Figure 5 Proposed models for the quaternary structure of E2 components in the core of the PDH complex

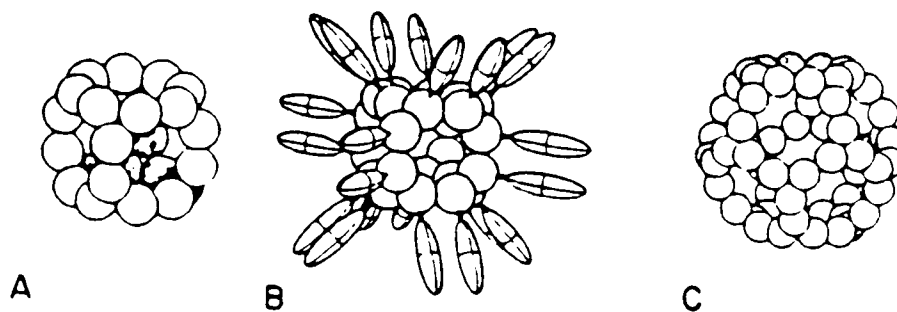

Interpretative models of the quaternary structure of dihydrolipoamide acetyltransferase. A) Model of 60-mer arranged in groups of 3 about 20 vertices of a pentagonal dodecahedron in the E2core. B) is A illustrating the proposed domain and subunit structure. The figure is viewed down a 2-fold axis of symmetry. C) Model of 24 subunit E2 core in cubic formation. Diagram adapted from Reed and Yeaman (1987).

the acetyltransferase reaction takes place in the inner E2 core. The flexibility of the E2 core at the domain-linker regions allow the transfer of substrate between the three active sites in succession (Reed and Hackert, 1990; Perham, 1991). The sequence of reactions is given in Figure 6. The PDH complex reaction is given below.

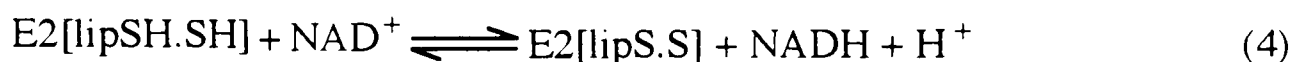

The holoreaction of the PDH complex is irreversible: $K_{eq} = 8.4 \times 10^6$ at pH 7 and $\Delta G^\circ = -39.5 \text{ kJ/mol}$. Irreversibility is conferred by the E1 reaction (equation 1). The other reactions are reversible. The kinetic constants for the substrates of porcine heart PDH complex are given in Table 3.

4 Regulation of PDH complex activity

Allosteric inhibition

Using purified porcine heart PDH complex, activity has been shown to be allosterically inhibited. Sodium pyrophosphate, adenylyl imidodiphosphate (which is a non-phosphorylating analogue of ATP), GTP and ADP are competitive inhibitors; acetoin is uncompetitive; and glyoxylate is uncompetitive with respect to TPP (Cooper *et al.*, 1974) but does not affect TPP binding indicating that it does not act *via* the TPP binding site (Walsh *et al.*, 1976). 3-hydroxybutyrate and α -ketobutyrate are competitive inhibitors with respect to pyruvate. The kinetic constants, for inhibition of porcine heart PDH are given in Table 4. Similar data are given by Hucho *et al.* (1972) for bovine heart and kidney complexes.

Figure 6 The reactions and sequence of reactions of the pyruvate dehydrogenase complex

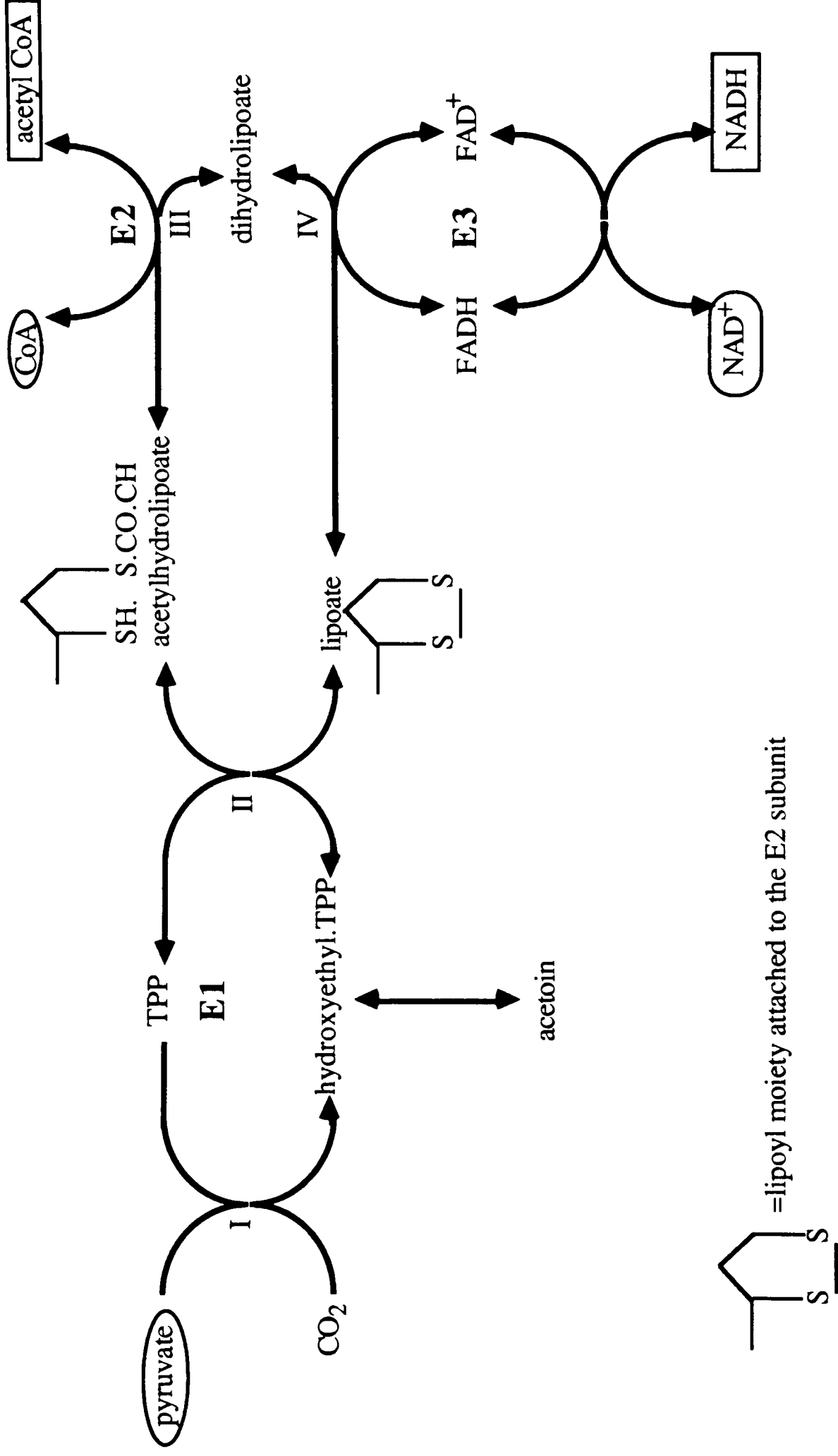

Substrates of the reaction are encircled and the products boxed. Letters I-IV represent the reactions of the holocomplex. E1=pyruvate dehydrogenase, E2 = dihydrolipoyl acetyltransferase, and E3 = dihydrolipoyl dehydrogenase.

Table 3 Kinetic constants for the substrates of porcine heart PDH complex

Substrate	K_m (μM)
Pyruvate	25
CoA	2
NAD ⁺	53
Thiamine pyrophosphate†	0.05 (at saturating pyruvate concentrations)
Glyoxylate	750
Acetoin	430
Pyruvate*	25
Thiamine pyrophosphate*†	0.11 (at 110 μM)

* For NAD⁺ and NADH independent decarboxylation. † The K_m for TPP depends on the pyruvate concentration. Kinetic constants are taken from Cooper *et al.* (1974) and Walsh *et al.* (1976).

Table 4 Kinetic constants for metabolite inhibitors of the porcine heart PDH complex reaction

Inhibitor	K_i (μM)
acetyl-CoA	15 (competitive with respect to CoA; K_m $2\mu\text{M}$)
NADH	50 (competitive with respect to NAD ⁺ ; K_m $53\mu\text{M}$)
acetoin	70 (competitive with pyruvate; K_m $25\mu\text{M}$)
glyoxylate	500 (competitive with respect to pyruvate; K_m $25\mu\text{M}$ non-competitive with respect to TPP)
sodium pyrophosphate	225 (competitive with respect to TPP)
ADP	1118 (competitive with respect to TPP)
adenosine 5'-[$\beta\gamma$ -imido] triphosphate (AMP-PNP)	507 (competitive with respect to TPP)

Data are taken from Cooper *et al.* (1974) and Walsh *et al.* (1976).

End product inhibition

Mammalian PDH complexes are inhibited by the end products, acetyl-CoA and NADH, of the holocomplex reaction. This inhibition is competitive; acetyl-CoA is competitive with CoA and NADH is competitive with NAD⁺, and also pyruvate is competitive with acetoin. Given that there is a limited concentration of CoA within the mitochondria, the PDH complex activity is thus, regulated by the concentration ratios of [acetyl-CoA]/[CoA], [NADH]/[NAD⁺] and [pyruvate]/[acetoin] (Garland and Randle, 1964a; Randle *et al.*, 1966; Tsai *et al.*, 1973; Cooper *et al.*, 1974). The kinetic constants for metabolite inhibitors of porcine heart PDH complex are given in Table 4. The mechanism of inhibition, by end products is reduction or reductive acetylation of the lipoate of the E2 component of the complex. The non equilibrium reaction of the E1 component is inhibited by the accumulation of E1-bound hydroxyethyl TPP carbanion. The reactions of E2 and E3 are reversible and the reverse reaction can produce acetyl hydrolypoyl-E2 and hydroxyethyl TPP-E1, and thus the holocomplex is inactivated.

During the onset of starvation or the development of alloxan-diabetes the ratio of [acetyl-CoA]/[CoA] in perfused heart is elevated. The starvation induced increase in the ratio of [acetyl-CoA]/[CoA] ratio can be reversed with tetradecylglycidate which is a β -oxidation inhibitor, by restoring normal levels of [acetyl-CoA]/[CoA] (Caterson *et al.*, 1982). Since tissue levels of acetyl-CoA are greatly elevated in heart muscle oxidising fatty acids, ketone bodies or acetate, it was concluded that this elevation was important in the inhibition of pyruvate oxidation under these conditions. An increase in either [NADH]/[NAD⁺] or [acetyl-CoA]/[CoA] decreases the proportion of PDH complex in the active form (Hansford, 1976; Kerbey *et al.*, 1976, 1977).

Initially end product inhibition was thought to be the mechanism whereby flux through glycolysis and the oxidation of pyruvate by the PDH complex was diminished during fatty acid or ketone body oxidation as a result of the more than 20-fold increase in the concentration ratio of [acetyl-CoA]/[CoA] increases by more than 20-fold (Garland and Randle, 1964; Randle *et al.*, 1970). This view has been modified by the discovery of reversible phosphorylation (see below). End product inhibition is an important mechanism of regulation in liver, and is a general means of rapid adjustment of flux.

Reversible phosphorylation

Quantitatively, the most important means of regulating PDH complex activity is by interconversion of the complex between phosphorylated and dephosphorylated forms. This mechanism of regulation of the PDH complex was first described by Linn *et al.* (1969 a,b). PDH complex is inactivated by its phosphorylation, catalysed by PDH kinase, and the phosphorylated form is activated by dephosphorylation, catalysed by PDH phosphatase.

The activity of PDH complex (or the portion of PDH in the dephosphorylated state, PDHa) can be measured in prepared tissues or mitochondria, by extraction of PDH complex in media containing EGTA and F^- (which prevent interconversion), and protease inhibitors. The PDH kinase and PDH phosphatase are known to be active simultaneously because studies utilising [^{32}P] phosphate incorporation have shown P_i turnover in the complex in tissues and mitochondria (Hughes and Denton, 1976; Sale and Randle, 1980, 1982). Total PDH complex activity (PDHa plus PDHb) can be measured after conversion of PDH b to a with PDH phosphatase. The inverse relationship between [ATP] and PDH complex activity has been shown in mitochondria from rat liver (Portenhauser and Wieland, 1972; Walajtys *et al.*, 1974), in rat white adipose tissue (Martin *et al.*, 1972) and in rat heart muscle (Whitehouse *et al.*, 1974; Kerbey *et al.*, 1976). (Such methods were probably not wholly quantitative as there is evidence that extraction of both forms is incomplete unless special precautions are taken (Fatania *et al.*, 1986).) Studies such as these have shown that the proportions of the PDH complex in the active form is altered by physiological and pathophysiological conditions, but that the PDH complex concentration (*i.e.* sum of PDHa and PDHb) is unchanged. [The one exception to this found so far is in rat epididymal tissue where total PDH complex is decreased by feeding rats high fat diets for 22 days (Stansbie *et al.*, 1976).] Thus, flux through the PDH complex, *in vivo*, is associated with corresponding changes in per cent active complex.

Factors regulating the percentage of PDHa in tissues and in vivo. The per cent of PDH complex, in the active form, has been shown to decrease in rat heart, skeletal muscle, liver, kidney and adipose tissue, *in vivo*, by starvation, high fat low carbohydrate diets and by diabetes (experimental forms induced by alloxan or streptozotocin) (Wieland *et al.*, 1971b;

Hennig *et al.*, 1975; Kerbey *et al.*, 1976; Stansbie *et al.*, 1976; Hagg *et al.*, 1976). The effects of starvation or diabetes are maximal in 24 to 48h and are reversed over 24 to 48 hour, *in vivo*, by refeeding after starvation or insulin treatment of diabetes (insulin treatment Wieland *et al.*, 1971a). Muscle contraction increases per cent PDHa in skeletal muscle, *in vivo* (Hagg *et al.*, 1976).

Factors regulating percentage PDHa in tissue, in vitro. Most effectors given below have rapid and short term effects to alter the per cent PDH complex activity. Insulin rapidly increases per cent active complex in rat white and brown adipose tissue and mammary gland, and has a smaller effect in liver where fatty acid synthesis from glucose is prominent (Jungas, 1970; Coore *et al.*, 1971; Severson *et al.*, 1974; McCormack and Denton, 1977; Topping *et al.*, 1977; Baxter *et al.*, 1979; Assimacopoulos-Jeannet *et al.*, 1982). The hormone had no obvious effect in skeletal muscle or cardiac muscle. The mechanism of activation of the complex by insulin is unknown, though it is known to involve activation of PDH phosphatase (Hughes and Denton, 1976; Jarett *et al.*, 1982; Larner *et al.*, 1982).

Other rapid effects of hormones, in liver, include the effects of α -adrenergic agonists, glucagon and vasopressin which increase the percentage of PDHa (McCormack, 1985). In heart muscle, inotropic hormones (glucagon and β -adrenergic agonists) increase per cent PDHa 4-fold (Hiraoka *et al.*, 1980; McCormack and Denton, 1981). The effect is rapid, and is likely to be mediated by activation of PDH phosphatase by Ca^{2+} . Thus the effect of adrenaline could be prevented by the inclusion of Ruthenium Red - an inhibitor of Ca^{2+} transport into mitochondria (McCormack and Denton, 1981; McCormack and England, 1983). The Ca^{2+} content of mitochondria was increased in hearts perfused with adrenaline (Crompton *et al.*, 1983). An increase in cytosolic and also mitochondrial $[\text{Ca}^{2+}]$ is also found with skeletal muscle contraction. Per cent PDHa is elevated in skeletal muscle by contraction (Henning *et al.*, 1975; Hagg *et al.*, 1976), and in cardiac muscle by increased work load (Illingworth and Mulling, 1976; Vary and Randle, 1984). Contributory factors in exercising muscle may be decreased $[\text{ATP}]/[\text{ADP}]$, $[\text{NADH}]/[\text{NAD}^+]$ and $[\text{acetyl-CoA}]/[\text{CoA}]$ ratios which may also increase percentage PDHa through inhibition of PDH kinase.

In tissue culture long term effects of glucagon and n-octanoate incubation decreased the percentage PDHa in hepatocytes from fed rats over 21 hours towards levels seen with starved rats (Fatania *et al.*, 1986). Thyroid hormone may be involved with the effects of starvation and refeeding on renal and hepatic per cent PDHa (Holness and Sugden, 1987).

The per cent active PDH complex is decreased by oxidation of fatty acids and/or ketone bodies in perfused rat heart, perfused rat liver, skeletal muscle and kidney. Elevation of plasma FFA, *in vivo*, decreases per cent PDHa in skeletal muscle (Holness and Sugden, 1990). Thus per cent PDHa is decreased in hearts perfused by the addition to the perfusate of acetoacetate, 3-hydroxybutyrate, octanoate or palmitate (Wieland *et al.*, 1971b; Whitehouse and Randle, 1973; Kerbey *et al.*, 1976). With glucose and insulin, in perfused hindquarter, per cent PDHa is decreased by acetoacetate (Hagg *et al.*, 1976). High fat feeding also decreased per cent PDHa in rat heart and skeletal muscle (Stansbie *et al.*, 1976; Vary and Randle, 1984). The effects of fatty acids on the percentage of PDHa require β -oxidation which can be blocked by inhibitors of fatty acid oxidation, such as sodium 2-tetradecylglycidate (Caterson *et al.*, 1982). The oxidation of fatty acids and ketone bodies is increased in starvation and diabetes (Garland and Randle, 1964 a,b; Berry *et al.*, 1965; Denton and Randle, 1967 a,b; Blackshear *et al.*, 1974, 1975). It appears that both end product inhibition and an increase in phosphorylation of PDH complex may be mediated by fatty acids and ketone body oxidation in starvation and diabetes.

Mechanisms of regulation of the activity of PDH complex by reversible phosphorylation. In the PDH complex, phosphorylation is confined to 3 serine residues in an α -chain of the E1 component of the complex. Phosphorylation is half site in bovine and porcine complexes, *i.e.* it involves only one α -chain in the $\alpha_2\beta_2$ tetramer of each component (Reed, 1974; Sugden and Randle, 1978). Only E1 is inactivated by phosphorylation; activities of E2 and E3 are unaffected (Walsh *et al.*, 1976). Relative rates of phosphorylation of the three sites are 1>2>3. Because of this, inactivation is largely due to (>90 per cent) phosphorylation of site 1. However, phosphorylation of site 2 can be inactivating in the absence of site 1 phosphorylation. This was demonstrated using thiophosphorylating ATP- γ -S analogues of ATP (Tonks *et al.*, 1982). The functions of phosphorylation of sites 2 and 3 appears to be in

retardation of reactivation by PDH phosphatase (Sugden *et al.*, 1978; Kerbey *et al.*, 1981; Tonks *et al.*, 1982; Sale and Randle, 1982a,b). Tryptic digestion of bovine or porcine phosphorylated complex yields 2 phosphopeptides; one contains sites 1 and 2 and the other site 3 (Sugden *et al.*, 1979). The amino acid sequences are given in Figure 7. Sites 1 and 2 can be separated, in two phosphopeptides, by formic acid treatment which breaks the peptide bond between the amino acid residues Asp Pro (Sale and Randle, 1982). The sequences of tryptic phosphopeptides from porcine and bovine complexes are apparently identical confirming earlier reports (Randle, 1986; Mullinax *et al.*, 1985). No allosteric activator of the phosphorylated complex has been reported. A further effect of phosphorylation may be on the association between E1 and the E2 core, since Pratt *et al.* (1979) have reported that unphosphorylated E1 exhibits a 9-fold greater affinity than phosphorylated E1 for the binding sites on the E2 core.

Relative rates of dephosphorylation are site 2 > site 1 ≥ site 3 for purified complex or complexes in mitochondria (Sale and Randle, 1982a,b). Phosphorylation of sites 2 and 3 decrease the rate of dephosphorylation of site 1, which means that the rate of reactivation of the complex, if these sites are occupied with phosphate, is decreased (Sugden *et al.*, 1978, Kerbey *et al.*, 1981; Sale and Randle, 1982 b). During dephosphorylation of mitochondrial complex, phosphorylation of site 1 accounts for 93 per cent of inactive complex and site 2, 7 per cent (Sale and Randle, 1982a,b; Sale and Randle, 1980).

5 PDH phosphatase

PDH phosphatase catalyses the dephosphorylation of phosphorylated PDH complex. Two phosphatases have been detected in bovine kidney mitochondria and are referred to as PDH phosphatase I and II. There is possibly a third PDH phosphatase. It has been detected in bovine heart mitochondria, is metal ion independent, is spermine insensitive, is not immunoprecipitated by antiphosphatase 2A antibody, is not inhibited by okadaic acid and is stimulated (>3 fold) by the putative insulin mediator purified from rat liver plasma membranes by the method of Suzuki

Figure 7 Amino acid sequence around seryl phosphorylation sites in tryptic phosphopeptides from fully phosphorylated pig heart PDH complex

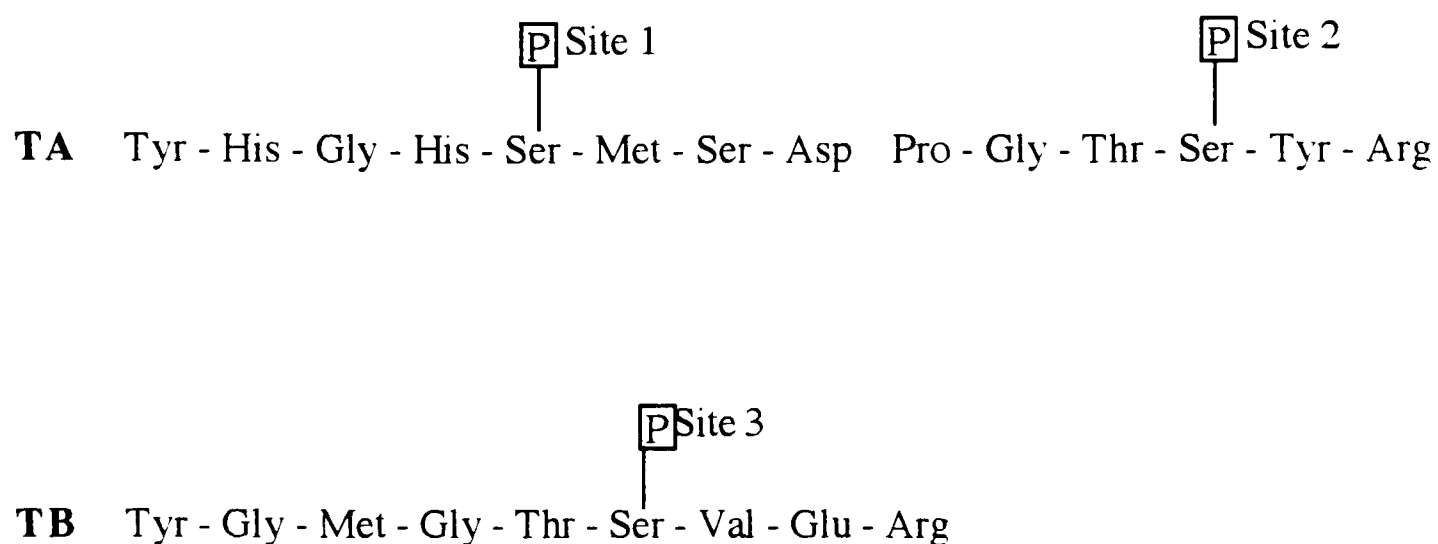

The symbol P represents phosphate at the phosphorylation site. PDH complexes contain three sites of phosphorylation on each α -subunit of the E1 component of the PDH complex. Tryptic digest phosphopeptides are represented as TA and TB (Sugden *et al.*, 1979). Formic acid treatment cleaves the peptide bond between Asp and Pro into two phosphopeptides, of TA (Sale and Randle, 1982).

et al. (1987) (Lilley *et al.*, 1992).

Structure of the PDH phosphatases

PDH phosphatase I has been purified to apparent homogeneity from bovine heart and kidney mitochondria (Teague *et al.*, 1982; Pratt *et al.*, 1982). Pratt *et al.* (1982) have found the molecular weight to be 150 000, with a catalytic subunit M_r 50 000 and subunit M_r 97 000. The latter subunit contains a single molecule of FAD⁺ with unknown function. PDH phosphatase II has been isolated from bovine kidney mitochondria by Damuni and Reed (1987). It has an apparent molecular weight of 140 000 - 170 000 Da and also has a subunit structure made of two dissimilar subunits. The one subunit has M_r of 60 000 and the other subunit has M_r 34 000. The latter subunit has the phosphatase activity. In extracts of bovine kidney mitochondria, PDH phosphatase II activity contributed up to 23 per cent of the total protein phosphatase activity toward [³²P]-labelled phosphorylated PDH complex.

Structural relationship of PDH phosphatase with PDH complex. PDH phosphatase binds, weakly, to the E2 component of PDH complex, and is readily separated from the complex by high speed centrifugation (Linn *et al.*, 1969a,b). (The PDH complex is sedimented and PDH phosphatase remains in the supernatant.) The exact stoichiometry of the interaction of PDH phosphatase with PDH complex is uncertain, and estimates suggest that approx. 5 PDH phosphatase enzymes are associated with the holocomplex. Most information, however, concerns the activity of PDH phosphatase I.

Regulation of PDH phosphatase activity

Regulation of PDH phosphatase I activity. Mg²⁺ is an essential cofactor for full PDH phosphatase activity (Linn *et al.*, 1969 a,b). The K_m for Mg²⁺ is calculated to be 0.5-1.0mM (Randle *et al.*, 1974). In the presence of Mg²⁺, PDH phosphatase activity is enhanced by Ca²⁺ with K_m of approx. 0.7 μ M (Denton *et al.*, 1972; Severson *et al.*, 1974). The major effect of Ca²⁺, with respect to enhancing phosphatase activity, is to lower the K_m of the phosphatase for its substrate, phosphorylated PDH complex, from about 30 μ M, in the absence of Ca²⁺, to about

1.6 μ M in its presence (Severson *et al.*, 1974). Ca^{2+} also decreases the K_m for Mg^{2+} (Denton *et al.*, 1972). At saturating a Mg^{2+} concentration (~ 10mM), phosphatase activity toward its physiological substrate, phosphate bound E1, is stimulated about 10 fold by micromolar concentrations of Ca^{2+} (Pettit *et al.*, 1972, Denton *et al.*, 1972). However, phosphatase activity toward uncomplexed phosphate bound E1 and other protein and phosphopeptide substrates is not affected by Ca^{2+} (Davis *et al.*, 1977). PDH phosphatase, itself, binds Ca^{2+} , (at a ratio of 1:1), at pH 7.0 and its dissociation constant is 35 μ M. In the presence of E2, a second Ca^{2+} binding site, on the phosphatase, is exposed (Teague *et al.*, 1982), and it is thought that Ca^{2+} may act as a bridging ligand to position the catalytic subunit of the phosphatase on the E2 core near its substrate (Pettit *et al.*, 1972). Use has been made of this in purification studies: phosphatase binds to an E2-affinity column, which is dependent on Ca^{2+} binding, and the phosphatase can then be eluted in the presence of EGTA. Studies have been made on the specificity of the metal ion requirement: Mn^{2+} may replace Mg^{2+} (Hucho *et al.*, 1972). Sr^{2+} and La^{3+} , and to a lesser extent Mn^{2+} , mimic the effects of Ca^{2+} . No effect was found with Ba^{2+} , Cu^{2+} , Co^{2+} or Fe^{2+} . Ni^{2+} and Zn^{2+} inhibited the effect with Ca^{2+} . F^- directly inhibits PDH phosphatase (K_i 800 μ M) (Hucho *et al.*, 1972; Siess and Wieland, 1972). Although phosphatase activity is stimulated by 0.5mM spermine, apparently by decreasing the apparent K_m for Mg^{2+} , it cannot substitute for Mg^{2+} , but at saturating Mg^{2+} levels phosphatase activity is stimulated up to 3-fold and at 300 μ M- Mg^{2+} activity is stimulated 20- to 30-fold (Damuni *et al.*, 1984). Spermine apparently acts directly on the phosphatase (Rahmatullah and Roche, 1988). Inorganic phosphate inhibits phosphatase (Hucho *et al.*, 1972). NADH also inhibits PDH phosphatase activity and can be reversed by NAD^+ (Pettit *et al.*, 1975). But not toward uncomplexed phosphorylated E1. It has been suggested that NADH does not act directly on phosphatase, but rather reduces E3 which, in turn reduces the lipoyl moieties on E2, and that the dihydrolipoyl moieties inhibit the phosphatase (Rahmatullah and Roche, 1988).

The second subunit of PDH phosphatase is a flavoprotein (FAD). Attempts to isolate a clone from bovine cDNA libraries have been unsuccessful. A search of protein databases revealed about 35 per cent sequence identity between the subunit fragment and rat liver

dimethylglycine dehydrogenase (Lang *et al.*, 1991) but the significance of this result is unsure.

Examination of the deduced amino acid sequence of the catalytic subunit (Lawson *et al.*, 1993) revealed the presence of a putative 'helix-loop-helix Ca^{2+} ' binding motif. Preliminary test with site directed mutagenesis indicate that an Asp residue at position 173 in the sequence plays an important role in phosphatase activity.

There is substantial evidence that the activation of PDH phosphatase by an increase in mitochondrial $[\text{Ca}^{2+}]$ may mediate increases in per cent PDHa effect by exercise in muscle and by hormones which increase intracellular $[\text{Ca}^{2+}]$ in liver (*e.g.* by vasopressin, α -adrenergic agonists) and cardiac muscle (McCormack, 1985; McCormack and Denton, 1981). Denton and co-workers have presented convincing evidence that insulin increases per cent PDHa in epididymal adipocytes through activation of PDH phosphatase (Taylor and Jungas, 1974; Weiss *et al.*, 1974; Denton *et al.*, 1975; Hughes and Denton, 1976; Denton *et al.*, 1984). PDH complex activity is stimulated by insulin in several tissues, particularly in adipose tissue. Insulin action leads to an increase in the dephosphorylated form of the enzyme (Jungas, 1971; Linn *et al.*, 1969). Macauley and Jarett (1985) demonstrated that the specific interconverting enzyme under insulin control was its phosphatase. They clearly demonstrated that a substrate was produced when insulin interacted with plasma membranes which stimulated PDH phosphatase in mitochondria.

Regulation of PDH phosphatase II activity. PDH phosphatase II activity is not dependent upon divalent ions. Spermine stimulates the enzyme by 1.5- to 3-fold, at pH 7.0-7.3, with K_a 0.5mM. It shifts the pH optimum of the reaction from 6.9-7.1 to 7.6-8.0. The phosphatase is inhibited by GTP, GDP, ATP and ADP with K_i between 0.11 and 0.19mM. At 2.5mM, spermine reverses inhibition by these nucleotides. Unlike PDH phosphatase I, PDH phosphatase II is inhibited by antiserum raised against the catalytic subunit of protein phosphatase 2A. PDH phosphatase II can dephosphorylate branched chain α -ketoacid dehydrogenase and phosphorylase A at 25 and 60 per cent of the rate of dephosphorylation of phosphorylated PDH complex. It is inactive with respect to p-nitrophenylphosphate (Damuni and Reed, 1987; Reed and Damuni, 1987).

Regulation of PDH phosphatase activity by multisite phosphorylation of PDH complex.

The phosphorylation status of the PDH complex influences the activity of PDH phosphatase. The initial rate of reactivation of partially phosphorylated PDH complex (80-90 per cent phosphorylation of site 1) is approx. 5 times that of fully phosphorylated PDH complex (sites 1, 2 and 3 phosphorylated). The conclusion is that phosphorylation of sites 2 and 3 inhibits reactivation of the complex, by inhibiting dephosphorylation of site 1 by PDH phosphatase (Sugden *et al.*, 1978; Kerbey and Randle, 1979; Sugden and Simister, 1980; Kerbey *et al.*, 1981). Further evidence for this conclusion came from studies in which thiophosphorylation of sites 2 and 3 in the PDH complex phosphorylated in site 1 was shown to inhibit dephosphorylation of site 1 (Radcliffe *et al.*, 1980; Tonks *et al.*, 1982). Thiophosphorylated PDH complexes, prepared using ATP- γ -S, are reactivated only very slowly by PDH phosphatase (Radcliffe *et al.*, 1980). However, Teague *et al.* (1979) were unable to detect any effects of phosphorylation of sites 2 and 3 on the dephosphorylation of site 1 and the difference may have been due to the different buffer systems used in each study (Sugden and Simister, 1980).

With fully phosphorylated PDH complex the relative rates of dephosphorylation of sites is $2 > 1 \geq 3$ (Sale and Randle, 1982a). Using tryptic digest, fully phosphorylated PDH complex can be divided into two phosphopeptides, one containing phosphorylation sites 1 and 2, and the other containing site 3. Using these phosphopeptides the apparent K_m for dephosphorylation of each has been calculated. For site 1 and site 2, both phosphorylated, the K_m is $625 \mu\text{M}$, for site 1 the K_m is $220 \mu\text{M}$ and for site 3 is $106 \mu\text{M}$. From the rate of release of $[^{32}\text{P}]$ from $[^{32}\text{P}]$ phosphorylated PDH complex, the respective rates of dephosphorylation (V_{max}) were estimated to be 6.4 (site 1), 9.0 (site 2) and 1.0 (site 3) mol of $[^{32}\text{P}]$ per minute per mole of phosphatase. This may suggest that site 3 can bind the phosphatase more tightly, yet be dephosphorylated more slowly than site 1, providing a mechanism of inhibition of reactivation by phosphorylation of site 3.

There is another mechanism of activation of PDH phosphatase which is not yet fully defined, and is concerned with the rapid action of insulin to increase percentages of PDHa in rat adipocytes and possibly hepatocytes. This effect of insulin apparently involves activation of PDH phosphatase by some novel mechanism (*i.e.* not involving Ca^{2+} nor polyamines)

(Marshall *et al.*, 1984; Thomas and Denton, 1986; Rutter *et al.*, 1992). Current knowledge of the action of insulin would suggest participation of the tyrosine kinase activity of the insulin receptor, guanine nucleotide regulatory protein(s), multiprotein kinase pathways and possibly the generation of an inositol phosphate glycan of $M_r \sim 1000$ second messenger by the action of a phosphatidyl-inositol-glycan-specific phospholipase C (Fox *et al.*, 1987; Gawler and Houslay, 1987; Bernier *et al.*, 1987; Larner *et al.*, 1989; Saltiel, 1994). Other proposals for the mediator include Ca^{2+} , Mg^{2+} and a postulated large molecular-weight component in the inner mitochondrial membrane that may be directly involved in the transmission of the insulin signal across this membrane (Reed and Damuni, 1987; Denton *et al.*, 1989). The possibility that insulin may decrease the concentration ratios of metabolites ($[\text{acetyl-CoA}]/[\text{CoA}]$, $[\text{NADH}]/[\text{NAD}^+]$ or $[\text{ATP}]/[\text{ADP}]$) to activate PDH complex and inhibit PDH kinase (Paetzke-Brunner *et al.*, 1978) was excluded when it was shown that insulin had no effect on these concentration ratios in adipocytes (Denton *et al.*, 1984).

6 PDH kinase

PDH kinase, with MgATP, catalyses the phosphorylation of serine residues in the α -chain of the E1 component of the PDH complex.

Structure of PDH kinase

PDH kinase has been purified to apparent homogeneity from PDH complex from bovine kidney by Stepp *et al.* (1983) and from rat heart by Harris *et al.* (1992). By purification, N-terminal sequencing, and cDNA cloning sequencing, rat heart has been shown to contain two PDH kinases. They have been designated PDH kinase 1 and PDH kinase 2, have molecular weights (determined by SDS-PAGE) of 48 000 and 45000 respectively, and have 70 per cent sequence homology. Northern blotting showed that mRNA for K2 is abundant in most rat tissues studied, whereas K1 is abundant only in heart (Popov *et al.*, 1993, 1994).

(Unpublished results from Harris's laboratory indicate the presence of 4 distinct PDH kinases from rat heart.) Stepp *et al.* (1983) have purified PDH kinase from bovine kidney which yielded two subunits of 45 and 48kDa ($\alpha\beta$) and kinase activity was found on the 48kDa subunit and the other subunit exhibited phosphatase activity. The molecular weights found by Stepp *et al.* (1983) are similar to those of the two PDH kinases purified by Harris *et al.* (1992) but they may not be the same. Based on immunological data, bovine kidney kinase may correspond (80%) with rat heart (Priestman *et al.*, 1994).

PDH kinase reactions and specificity. PDH kinase activity requires ATP complexed with Mg^{2+} or Mn^{2+} . The K_m for MgATP is approx. 20-25 μ M (Cooper *et al.*, 1974; Pratt and Roche, 1979). PDH kinase can phosphorylate tryptic peptides of the PDH complex (Davis *et al.*, 1977), and synthetic peptides containing phosphorylation sites 1 and 2 (Mullinax *et al.*, 1985). However, the rate of phosphorylation is less than that for the E1 component of the complex and binding of both kinase and E1 to the E2 core increases the rate of phosphorylation further (Reed, 1981; Stepp *et al.*, 1983; Liu *et al.*, 1995). This is, presumably, due to a favourable topographical positioning of pyruvate decarboxylase with respect to the kinase, or may be due to changes in the conformation of either kinase, the pyruvate decarboxylase or of both enzymes on binding to the E2 core (Hucho *et al.*, 1972).

There are 3-6 kinase molecules per holocomplex. PDH kinase binds tightly to the E2 core *via* the inner (L2) domain of an E2 subunit in the core (Radke *et al.*, 1993). High speed centrifugation of purified PDH complexes shows that PDH kinase can be separated from the complex as a soluble kinase (Mistry *et al.*, 1991). Despite the fact that the kinase binds very tightly to the oligomeric E2 core, Ono *et al.* (1993) found that the kinase could rapidly be transferred to a fragment of bovine E2 that contained both lipoyl domains. Direct interchange of kinase between lipoyl domains of E2 core could explain how so few kinase molecules are able to phosphorylate and inactivate the E1 components of the holocomplex. Delipoylation, with lipoamidase, shows that the lipoyl prosthetic groups are required for the binding of the kinase to the L2 domains of E2.

PDH kinase activities have been assayed by either the rate of ATP-dependent inactivation

of the complex, and/or the rate of [^{32}P] phosphorylation of the complex, or its E1 component or of synthetic peptides (Hucho *et al.*, 1972; Mullinax, *et al.*, 1985). As described above initial rates of inactivation (phosphorylation of site 1) is pseudo first order and the PDH kinase activity is, therefore, conveniently expressed as the apparent first order rate constant (Kerbey and Randle, 1981). Incorporation of phosphate, [^{32}P], is multisite, and, therefore, pseudo first order rate kinetics can only strictly be applied on a site by site basis.

Regulation of PDH kinase activity

Investigations into the mechanism of regulation of the activity of PDH kinases has largely been studied in bovine kidney and heart, and porcine heart, and also of that in mitochondria from rat heart, skeletal muscle and liver.

Inhibition of PDH kinase. PDH kinase is inhibited by ADP, TPP, sodium pyrophosphate, dichloroacetate and other halogenated carboxylic acids, and high concentrations of pyruvate, (Linn *et al.*, 1969 a,b; Roche and Reed, 1972; Hucho *et al.*, 1972; Cooper *et al.*, 1974; Whitehouse *et al.*, 1974; Pratt and Roche, 1979). Competitive inhibitors, with respect to ATP, include ADP and AMP-PNP (Cooper *et al.*, 1974). Inhibition by pyruvate is enhanced by ADP possibly because pyruvate may bind to the {kinase ADP} intermediate (Pratt and Roche, 1979). The mechanism of inhibition is likely to be the binding of the adenosine moiety to the ATP binding site as PDH kinase is inactivated by AMP-PNP, or by fluorosulphonyl-benzoyl adenosine (Mistry *et al.*, 1991). Uncompetitive and non competitive inhibitors include TPP, sodium pyrophosphate, pyruvate and dichloroacetate (Cooper *et al.*, 1974). TPP and pyrophosphate bind to the catalytic site of E1 which alters the conformation about phosphorylation site 1 making it less accessible to the kinase, thus inhibiting PDH kinase indirectly (Roche and Reed, 1972). Effectors of PDH kinase influence phosphorylation of all sites of phosphorylation (Kerbey *et al.*, 1979). The kinetic constants are given in Table 5.

PDH kinase is inhibited by Mg^{2+} and 10^{-5} to 10^{-2}mM - Ca^{2+} in the presence of 0.15mM Mg^{2+} (Cooper *et al.*, 1974). The kinetic constants are also given in Table 5.

Interestingly common effectors of PDH kinase and PDH phosphatase act in a reciprocal

Table 5 Kinetic constants for inhibition of pig heart PDH kinase reaction

Inhibitor	K_i (μM)
CoA	inhibits
ADP	28 (competitive with respect to ATP)
AMP-PNP	39 (competitive with respect to ATP)
pyruvate	635 (uncompetitive with respect to ATP)
NAD ⁺	reverses NADH activation
Mg ²⁺	1300
Ca ²⁺	10 ⁻⁵ to 10 ⁻² mM
sodium pyrophosphate	146 (uncompetitive with respect to ATP)
thiamine pyrophosphate	14 (uncompetitive with respect to ATP)
dichloroacetate	100 (non-competitive with respect to ATP)

Data are from Cooper *et al.* (1974, 1975); Hucho *et al.* (1972); Linn *et al.* (1969a,b); Randle *et al.* (1974); Whitehouse *et al.* (1974).

manner. Ca^{2+} is a major activator of PDH phosphatase and inhibits PDH kinase at physiological concentrations (10nM-10 μ M) (Denton *et al.*, 1972; Cooper *et al.*, 1974). NADH inhibits PDH phosphatase, whereas its effect on kinase is as an activator (Reed, 1981; Cooper *et al.*, 1974).

Activation of PDH kinase activity by metabolites. The end products of the PDH complex reactions and of fatty acid oxidation, namely NADH and acetyl-CoA, enhance the activity of PDH kinase in the purified PDH complex (Pettit *et al.*, 1975; Cooper *et al.*, 1975; Kerbey *et al.*, 1976, 1979). It has been suggested that K^+ and NH_4^+ are necessary for this effect (Pettit *et al.*, 1975; Cooper *et al.*, 1975). The effects of NADH are reversed by NAD^+ , and those of acetyl-CoA are reversed by CoA. Activation by acetyl-CoA is dependent on the presence of a nonactivating, or partially activating, concentration ratio of $[\text{NADH}]/[\text{NAD}^+]$, and the maximum stimulatory effects of acetyl-CoA and NADH are not additive (Cooper *et al.*, 1975; Kerbey *et al.*, 1976; Cate and Roche, 1978).

Mechanism of activation of PDH kinase activity by metabolites. The mechanism of enhanced kinase activity by metabolites was at first thought to be allosteric involving direct interactions with PDH kinase (Reed, 1981). The idea that these effectors activate the kinase through covalent modifications of lipoate in the PDH complex was first proposed by Cooper *et al.* (1974, 1975), and now substantial evidence exists for this second mechanism (Rahmatullah and Roche, 1985). Of particular significance was evidence that reduction by SH compounds (reversed by NAD^+) could mimic effects of NADH; that NADH was required for acetyl-CoA activation; and that low concentrations of pyruvate activate PDH kinase provided TPP was present (higher concentrations are inhibiting). The mechanism of activation is the build up of reduced and acetylated forms of the L2 lipoyl moieties of the E2 component by the reverse reactions of E2 and E3, and the L2 domain becomes specifically engaged in binding kinase, and results in allosterically induced conformational changes that generate active kinase. *Via* lipoyl-dependent binding to the L2 domain, rapid 'hand-over-hand' interchange of a kinase dimer between lipoyl domains apparently eliminates normal association with binding. This binding is as tight as exists between E2 and the kinase (Ono *et al.*, 1993; Liu *et al.*, 1995). The time course for activation or inhibition of the kinase is rapidly reversible and is therefore described as

short term.

Evidence for further, unknown and long term mechanism(s) of PDH kinase activation.

A second mechanism for the activation of PDH kinase was first suggested by the observation that the proportion of PDH complex in the a form in hearts from alloxan-diabetic or starved rats (1-2 per cent) was lower than can be induced *in vitro* by oxidation of free fatty acids or ketone bodies (7 per cent). It was then discovered that the effect of starvation or diabetes to lower per cent active complex persists into muscle mitochondria incubated *in vitro* with α -ketoglutarate and L-malate (Kerbey *et al.*, 1976; Fuller and Randle, 1984). Also, inhibiting PDH kinase activity with pyruvate or dichloroacetate, allows almost complete conversion of PDHb to PDHa, but the starved-fed difference in kinase activity, even with the use of these inhibitors, remained. These result indicated and were confirmed by Kerbey *et al.* (1977), that the starved-fed difference in kinase activity was not explicable in terms of altered mitochondrial concentrations of known effectors of the kinase (NADH, ATP, and acetyl-CoA).

It was subsequently shown that the PDH kinase activity of extracts of heart mitochondria from 48h starved or diabetic rats is increased approx. 3-fold relative to fed normal controls (Hutson and Randle, 1978). In these experiments the mitochondria were incubated under conditions (no substrate or uncoupler of oxidative phosphorylation), which effected complete conversion of PDHb to PDHa and which removed known activators of PDH kinase the PDH kinase was assayed in extracts by both methods; *i.e.* the rate of ATP dependent inactivation and the rate of [³²P] phosphorylation of PDH complex by [γ -³²P]ATP (Hutson and Randle, 1978). Similar observations have been made with PDH complex from rat mammary gland (Baxter and Coore, 1978), rat skeletal muscle (Fuller and Randle, 1984) and rat liver (Denyer *et al.*, 1986). More recently the effect of starvation to increase PDH kinase activity in extracts of liver mitochondria has also been demonstrated with an assay based on [³²P]phosphorylation of a synthetic peptide reproducing the amino acid sequence around phosphorylation sites 1 and 2 of E1 (Jones *et al.*, 1992).

The mechanism of starvation to induce increases in PDH kinase and decreases in per cent PDHa requires 24-48h to reach a maximum are described as long term. Complete reversal of the

starvation effect requires a period of refeeding of similar duration (Kerbey and Randle, 1982). More detailed studies revealed major increases in per cent PDHa on refeeding between 4 and 8h (Holness and Sugden, 1989; Jones *et al.*, 1992). What these show is that there is a mechanism of regulation of the PDH kinase of much longer latency than the effects of substrate and products of the PDH complex reactions, *i.e.*, the studies indicate that there was a longer term mechanism of regulation of the kinase, *in vivo*, physiological (starvation) and also with pathophysiological (diabetes) conditions.

Evidence concerning the factors that may produce this stable increase in PDH kinase activity in 48h starved and alloxan-diabetic rats has been sought by use of hepatocytes, cardiac myocytes and soleus muscle strips in tissue culture (Fatania *et al.*, 1986; Marchington *et al.*, 1989, 1990; Stace *et al.*, 1992). These studies showed uniformly that culture of cells from fed rats with agents that increase cAMP or reproduce its effects (glucagon in hepatocytes or dibutyryl cAMP more generally) or with fatty acids (n-octanoate or albumin bound palmitate) or with a combination, increases PDH kinase activity 2-3-fold (as measured by the rate of ATP-dependent inactivation of PDH complex). In hepatocytes the effect of glucagon was completely reversed by insulin (known to lower cAMP in the presence of glucagon). Insulin had no effect in the presence of dibutyryl cAMP, thus confirming that reversal of the glucagon effect was due to lowering the cAMP. Insulin partially reversed the effect (approx. 60 per cent) over 24h of culture, and this reversal was blocked by n-octanoate or dibutyryl cAMP or a combination. In hepatocytes no consistent effect of insulin on reversal of the effect of starvation was seen. It is clear from these studies the action of insulin in longer term regulation of PDH kinase activity, *in vivo*, is confined to interactive regulation of intracellular cAMP concentration and to regulation of free fatty acids concentration through effects on lipolysis, esterification and possibly carnitine acyltransferase I *via* malonyl-CoA and acetyl-CoA carboxylase. Orfali *et al.* (1993, 1995) have made the additional observations: that high fat diet and also hyperthyroidism increased PDH kinase activity in rat heart; the effect of the latter was additive with that of starvation; that T3 increased PDH kinase activity in cardiac myocytes in culture; and that the effect of T3 was suppressed by insulin.

Molecular mechanisms involved in longer term regulation of PDH kinase activity are not yet known. In this laboratory a free form of PDH kinase was purified to homogeneity from rat liver mitochondria of fed and 48h starved rats and homogeneity was confirmed by N-terminal amino acid sequencing of kinase these preparations. The N-terminal sequences were identical but the activity of the kinase purified from starved rats was some 4.5-fold greater than that from fed rats (Mistry *et al.*, 1991; Priestman *et al.*, 1992, 1994) and provided evidence for a post translational modification of the kinase structure. Based on the N-terminal sequence, this kinase corresponded with the K2 of Popov *et al.* (1994) and Harris *et al.* (1992). Studies in tissue culture showed that the effect of dibutyryl cAMP was blocked by the protein synthesis inhibitor cyclohexamide, whereas the effect of free fatty acid (palmitate) was not. The effect of palmitate was blocked by the carnitine acyltransferase I inhibitor Etomoxir whereas that of dibutyryl cAMP was not. By ELISA of K2, evidence was obtained that the major effects of free fatty acids and dibutyryl cAMP in culture, like those of starvation *in vivo*, were to increase the specific activity of K2 and not its concentration (Priestman *et al.*, 1994). The mechanism proposed for the effect of starvation and alloxan-diabetes to reduce per cent active PDH complex is given in Figure 8.

Specific activation of PDH kinase would lead to phosphorylation of sites 2 and 3 and thus inactivation, and a decrease in the rate of dephosphorylation by PDH phosphatase. In starvation there is a greater degree of phosphorylation of sites 2 and 3 which may explain how the mechanism of specific activation of the kinase could work, *in vivo*, in starvation.

7 Outline for the dissertation

The aim of the main body of experiments presented in chapters 3-5 of this thesis was to investigate further the molecular mechanism(s) that may mediate the effects of starvation and diabetes to increase the specific activity of PDH kinase. On the basis of the information given above, it seemed possible that free fatty acids might activate the kinase in culture, through acylation of the kinase itself or of some protein associated with activation of the kinase, and that

Figure 8 Proposed model for the mechanism of the effect of starvation and alloxan-diabetes to reduce per cent active PDH complex in rat tissues.

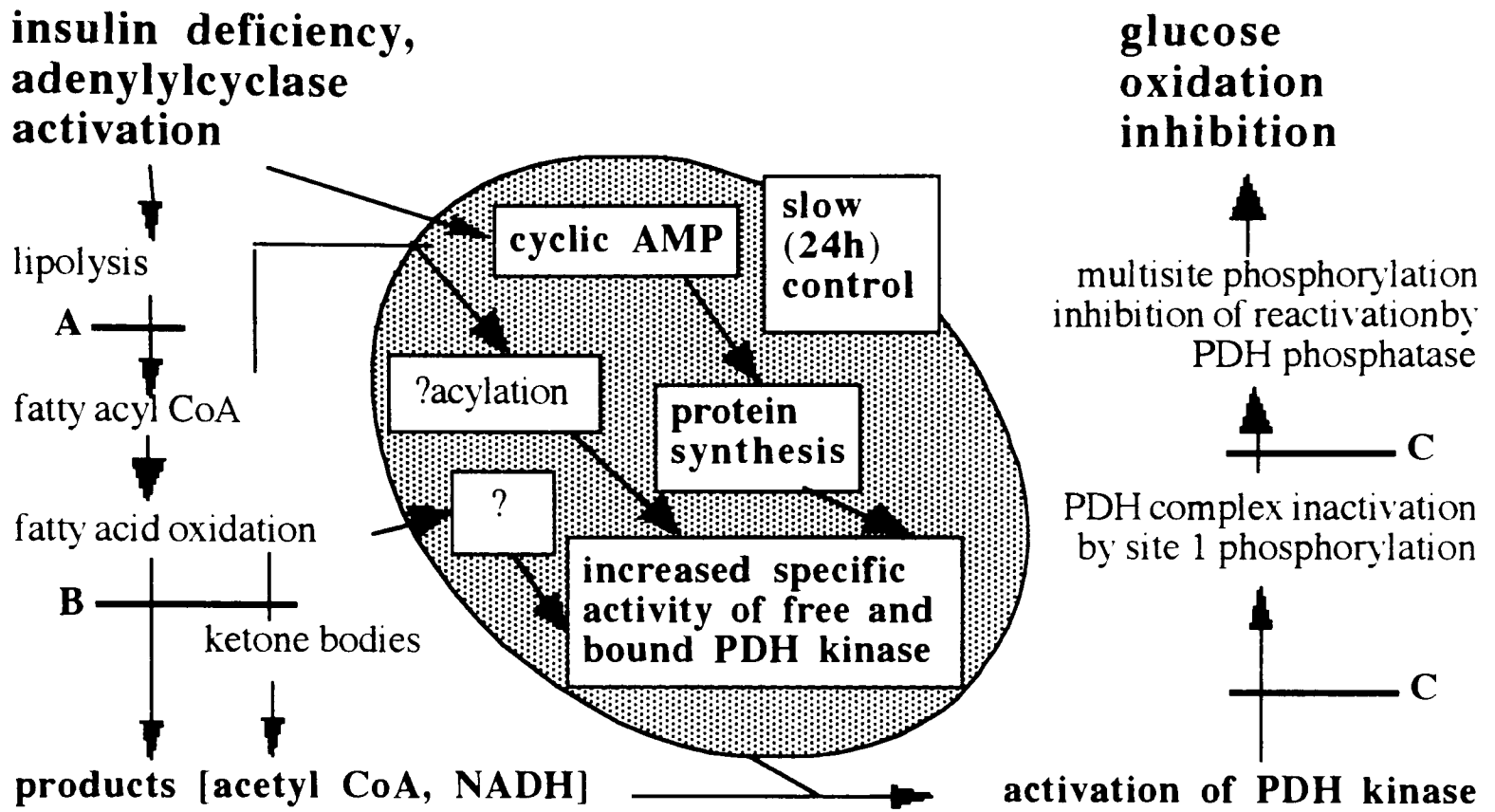

Mechanisms leading to phosphorylation and inactivation of the pyruvate dehydrogenase complex in starvation or insulin-deficient diabetes. Inhibitors of (A) lipolysis, (B) fatty acid oxidation and (C) PDH kinase.

cAMP might increase the concentration of this putative protein by an effect on its rate of synthesis. Because the effects of fatty acids in culture were blocked by Etomoxir it seemed reasonable to conclude that the carnitine acyl transferase was involved. It therefore seemed appropriate to investigate whether palmitoyl carnitine might activate PDH kinase in a stable manner in longer term incubations and if so whether incubations of mitochondrial extracts with palmitoyl-CoA would have similar effects. The hypothesis was that fatty acids (as the acyl-CoA derivative), utilising an enzyme present within the mitochondria, activate PDH kinase by acylation. It would also be of interest to ascertain whether or not further enhancement of kinase activity could be observed with palmitoyl carnitine/palmitoyl-CoA incubation with mitochondria from starved rats: *i.e.* whether acylation had already occurred *in vivo*. It was known from earlier work that the increase in PDH kinase activity induced by starvation *in vivo* or by fatty acids in tissue culture is stable, *i.e.* it persists through isolation of mitochondria and depletion of respiratory substrates by incubation *in vitro*, in the absence of respiratory substrates. Activation of the kinase has been measured both by an increase in the rate of ATP-dependent inactivation and by an increase in the rate of incorporation of [³²P] from [γ -³²P]-ATP into protein (essentially PDH complex).

The work in chapter 2 of this thesis is the project which I embarked upon as a new research student. The long term culture of rat soleus muscle strips, developed in this laboratory, was to be applied to a study of the factors which may regulate the accumulation and loss of triacylglycerol in skeletal muscle. In the event the considerable variation in triacylglycerol concentration between different soleus muscles suggested the possibility of variable contamination of small amounts of adipose tissue. In view of the uncertainties it was decided not to proceed further with this particular project.

Chapter 2

Long term regulation of triacylglycerol metabolism in skeletal muscle, *in vitro*

INDEX

	Page
Introduction	2.3
Materials and Methods	2.19
1 Materials	2.19
2 Solutions	2.20
3 Preparation of bovine serum albumin bound with palmitic and [³ H] palmitic acid	2.21
4 Rats	2.23
5 Sterility	2.23
6 Long term culture of soleus muscle strips <i>in vitro</i>	2.23
7 Measurement of skeletal muscle triacylglycerol	2.25
7.1 Triacylglycerol extraction	2.25
7.2 Methods of triacylglycerol hydrolysis	2.26
8 Recoveries of glycerol tri [¹⁴ C] palmitate	2.27
9 Thin layer chromatography	2.28
10 Simultaneous counting of ¹⁴ C and ³ H isotopes	2.28
11 Assay of glycerol	2.29
12 Definition of enzyme activity	2.30
13 Expression of results and statistical analysis	2.30
Results	2.31
14 Development of protocols	2.31
15 Control experiments	2.40
16 Time course for incorporation of 0.6mM [³ H]-palmitic acid into soleus muscle lipids <i>in vitro</i>	2.41
17 Incorporation of 0.6mM [³ H]-palmitic acid into soleus muscle triacylglycerol <i>in vitro</i> during long term culture	2.41
18 Effects of incubation of soleus muscle strips <i>in vitro</i> with 8-phenyltheophylline or adenosine deaminason on muscle triacylglycerol concentration	2.42
19 Triacylglycerol concentration in six freshly excised soleus muscles	2.42
Discussion	2.43

INTRODUCTION

The aim of the experimental work undertaken to complete this chapter was to investigate the long term molecular mechanisms that mediate the effects of diet or diabetes on triacylglycerol metabolism in skeletal muscle.

As described in detail in the general introduction, the rate of glucose uptake, phosphorylation by hexokinase, glycolysis through phosphofructo 1-kinase and oxidation via the pyruvate dehydrogenase complex is decreased *in vivo* by starvation, diabetes and high fat diets and *in vitro* by incubation of isolated rat skeletal muscle or perfusion of isolated rat hearts with fatty acids. The effects *in vivo* may be mediated by the increase in release from adipose tissue of free fatty acids (FFA) into the circulation, leading to increased uptake by muscle and glucose sparing tissues, and oxidation of fatty acids (and ketone bodies) to inhibit glucose metabolism in these tissues. The basal mechanisms of control of glucose and fatty acid metabolism, independent of hormones, were described as the glucose-fatty acid cycle. Although *in vivo* the cycle operates at the whole body level, there was evidence that it may function on a local level within muscle tissue itself.

It was suggested that the changes in glucose metabolism in heart and diaphragm muscle in diabetes and starvation are effected by enhanced respiration of endogenous fatty acids (Garland, *et al.*, 1962). Free fatty acid concentrations measured in diaphragm muscles or hearts of alloxan-diabetic rats incubated or perfused *in vitro* with glucose and insulin were greater than normal controls (Garland and Randle, 1963; Randle *et al.*, 1964). The breakdown of endogenous glyceride in muscle of starved or diabetic rats was increased, in comparison with that from fed normal rats, was shown by the increased output of glycerol from these muscles incubated *in vitro* (Randle *et al.*, 1963). Concentrations of intermediates of glyceride metabolism were measured in isolated rat hearts and diaphragms from diabetic or starved rats, or normal fed rats incubated with fatty acids. Alterations in free fatty acids (increased), fatty acyl-CoA (increased) and glycerol phosphate (decreased) concentrations indicated that the metabolism of glycerides contained within these muscles is increased (Garland and Randle, 1964). The

oxidation of glucose or glycogen glucose accounted for only part of the oxygen consumption of perfused rat heart and that even in the presence of glucose and insulin, in alloxan-diabetic hearts the proportion was less than that with perfused hearts from normal rats (Williamson and Krebs, 1961; Randle *et al.*, 1966). The balance was attributed to the oxidation of fatty acids released by the breakdown of muscle glycerides. Direct measurement of endogenous muscle glyceride showed that indeed, with alloxan-diabetes or starvation the muscle concentration of glyceride was increased (Denton and Randle, 1967). Incubation of muscle or perfusion of hearts without substrates lead to significant diminution of the glyceride concentration of hearts from either normal or diabetic rats. The specific lipid species that was most abundant and that fluctuated with the conditions given above was triacylglycerol and not di- or monoacylglycerols. No significant changes were found with phospholipid (Denton and Randle, 1967).

Evidence has shown that the triacylglycerol is present within muscle and not adipose-tissue cells in the preparation (Denton and Randle, 1967). Using light or electron microscopy and sections of hearts and gastrocnemius muscles stained for lipids, no adipose tissue cells were seen amongst the muscle fibres. Orth and Morgan (1962) have observed lipid droplets within muscle cells in sections of heart muscle with light and electron microscopy. Also the output of glycerol from diaphragm was as great and greater in heart muscle than that from adipose tissue indicating muscle cell lipolysis (Garland and Randle, 1964).

In the studies above, evidence showed that both lipolysis and esterification of triacylglycerol were increased in muscles from starved and diabetic rats. Storlien and co-workers have found with *in vivo* studies that high fat feeding increases plasma fatty acid concentration, skeletal muscle triacylglycerol concentration and has a deleterious effect on glucose metabolism in muscle, with both insulin stimulated and basal insulin concentrations (Kraegan *et al.*, 1986; Storlien *et al.*, 1986; Storlien *et al.*, 1991).

The precise mechanism whereby intracellular muscle triacylglycerol metabolism is increased in starvation, diabetes and high fat diets is unknown. Given below is a summary of the existing knowledge of the factors that might control triacylglycerol metabolism in muscle.

Triacylglycerol synthesis

Indications that triacylglycerol synthesis is increased by diet or diabetes, demonstrated by an increased muscle triacylglycerol content, has been found by numerous workers: in man in diabetes (Standl *et al.*, 1980; Falholt *et al.*, 1988), in the rat normal, 48h starved and alloxan-diabetes (Denton and Randle, 1967), soleus muscle rats streptozotocin diabetes (Stearns *et al.*, 1979), high fat feeding (Storlien *et al.*, 1991, Bingolf *et al.*, 1972; Schindler and Felber, 1986). Triacylglycerol synthesis is modulated by hormones and other factors. The cardiac content of triacylglycerol is increased on administration of isoproterenol (Jodalen *et al.*, 1982), during myocardial ischaemia (Trach *et al.*, 1986; Scheuer and Brachfeld, 1966), indirectly by growth hormone and cortisol (Denton and Randle, 1967), noradrenaline continuous infusion *in vivo* increases the number of stainable neutral lipid droplets in dog skeletal muscle and heart (Carlson *et al.*, 1965).

Triacylglycerol synthesis is the enzymatic esterification of 3 fatty acids with glycerol. The pathway for triacylglycerol synthesis is well established for lipogenic tissues and was identified in the microsomal fraction of rat skeletal muscle (Neptune *et al.*, 1962; Neptune *et al.*, 1963). The pathway of triacylglycerol synthesis is given below.

Pathway of triacylglycerol synthesis

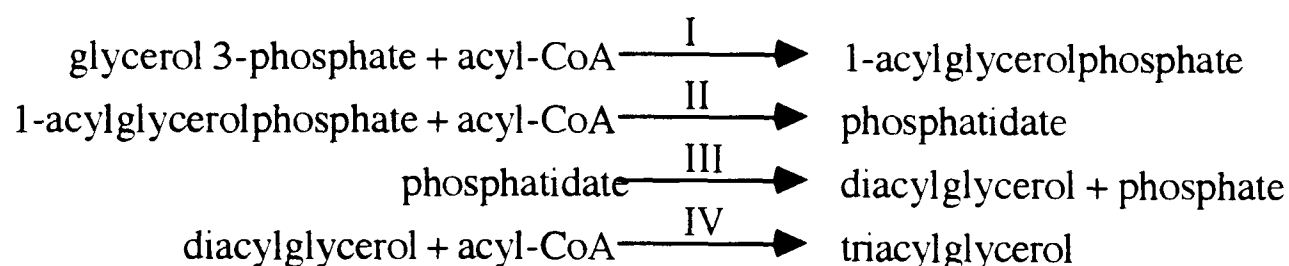

where I is glycerolphosphate acyltransferase (GPAT)

II is 1-acylglycerolphosphate acyltransferase (MGAT)

III is phosphatidate phosphatase (PAP)

IV is diacylglycerol acyltransferase (DGAT)

The synthesis pathway may be controlled by substrate supply (glycerol 3-phosphate, acyl-CoA)

or regulation of enzyme activity (directly by regulation of the GPAT, MGAT, PAP or DGAT, or indirectly by those that generate substrates).

Glycerol 3-phosphate. Glycerol 3-phosphate for esterification can be formed from phosphorylation of glycerol or from conversion of dihydroxyacetone phosphate, generated by glycolysis, by the enzyme glycerol 3-phosphate dehydrogenase. Glycerol is unlikely to be a source of glycerol phosphate because glycerokinase is absent from heart and adipose tissue (heart Wieland and Suyter, 1957; Robinson and Newsholme, 1967; adipose tissue Margolis and Vaughan, 1962; Denton and Randle, 1967). Glycerol is exported by skeletal muscle which has provided a useful method of measurement of triacylglycerol breakdown (Vaughan, 1961). Evidence that the source of glycerol phosphate is from glycolysis in perfused rat hearts, is that lactate increases the triacylglycerol content by increasing cytoplasmic concentration ratio of NADH/NAD⁺ (deGroot *et al.*, 1989; Murthy *et al.*, 1983). (NADH reduces dihydroxyacetone phosphate to glycerol 3-phosphate by glycerol 3-phosphate dehydrogenase.) Evidence that glycerol phosphate concentration may not regulate triacylglycerol synthesis is that its intracellular concentration is decreased in alloxan-diabetes, *in vitro*, ($0.57\mu\text{mol/ml}$ in normal rat hearts and $0.22\mu\text{mol/ml}$ in alloxan-diabetic hearts) whereas triacylglycerol concentration is increased. [¹⁴C]-Glucose is not converted to free glycerol in perfused heart (Denton and Randle, 1967) or in isolated myocytes (Kryski *et al.*, 1985). Phospholipid is unlikely to be a source of glycerol phosphate because turnover of phospholipid in perfused heart (Kryski *et al.*, 1985; Olsen and Hoeschen, 1967; Crass, 1972; Gartner and Vahouny, 1973; Saddik and Lopaschuk, 1994) or isolated myocytes (Swanton and Saggerson, 1996; Kryski *et al.*, 1985) is very small under normoxic conditions and is minimal compared with triacylglycerol.

Acyl-CoA. Acyl-CoA is generated from the activation of fatty acids with CoA by the enzyme acyl-CoA synthetase. In heart, it is associated with membrane bounded lipid particles and has higher activities in mitochondria or microsomal fractions (Christiansen, 1975). Garland and Randle (1964) found that the concentration of acyl-CoA in heart in alloxan-diabetes was double that in normal hearts, and was increased by perfusion of hearts from normal rats with fatty acids, suggesting a possible role of acyl-CoA in the regulation of triacylglycerol synthesis in

muscle. Very little information exists concerning the regulation of fatty acyl-CoA synthetase in muscle. Starvation of yeast stimulated acyl-CoA synthase (Holdsworth and Ratledge, 1991). Administration of a single dose of palmitic acid to rats significantly increases long chain acyl-CoA synthase activity, in liver, within 12h (Skore *et al.*, 1995). Enoximone (a phosphodiesterase inhibitor) inhibited acyl-CoA synthetase activity (Youssef *et al.*, 1994). Acyl-CoA synthetase may be stimulated by a rise in fatty acid concentration and by cAMP independent mechanism.

Fatty acids. The possible sources of fatty acids are *de novo* synthesis in muscle, transport and uptake from plasma, bound to plasma albumin as non-esterified fatty acids; and esterified in triacylglycerol and either transported as free triacylglycerol or bound with lipoproteins, predominantly very low density lipoproteins (VLDL), or chylomicrons.

De novo synthesis. In rat hearts it would seem that no appreciable *de novo* synthesis of fatty acids occurs, since the incorporation of [¹⁴C]-labelled glucose, acetate or pyruvate into cardiac lipid is very small (less than 1%) compared with utilization of these substances by other metabolic pathways (Opie *et al.*, 1963; Pearson *et al.*, 1949a,b). Incorporation of U-[¹⁴C]-glucose into glyceride after perfusion of hearts showed that ¹⁴C was present in the glycerol moiety (Denton and Randle, 1967). *In vivo*, in the rat, incorporation of [¹⁴C] glucose into muscle lipids was negligible (James *et al.*, 1985). Acetyl-CoA carboxylase the enzyme that catalyses the carboxylation of acetyl-CoA in the flux generating step in fatty synthesis, is present in muscle (Bianchi *et al.*, 1990), but the levels of acetyl-CoA carboxylase are very much lower in cardiac and skeletal muscle in comparison with that in liver and adipose tissue. In contrast with liver, in cardiac and skeletal muscle, activity is unaltered by fasting or fasting/refeeding (Bianchi *et al.*, 1990).

Transport of non-esterified fatty acids. Physiologically important fatty acids are insoluble in water and most (99%) are transported bound to plasma albumin. Each albumin molecule has several sites with high affinities for fatty acids (Wosilait *et al.*, 1976) and bind fatty acids extremely strongly (Spector, 1975). The amount of plasma albumin changes very little and the effective plasma concentration of its high affinity binding sites is approx 4mM. The

concentration of fatty acids is very variable and depends on the nutritional and hormonal status. During starvation, diabetes or high fat feeding the concentration of fatty acids is increased (Newsholme, 1967; Hall *et al.*, 1978; Gordon and Cherkes, 1956).

Uptake of non-esterified fatty acids. Fatty acids are transported into the cell as unbound fatty acids by absorption onto membrane fatty acid-binding proteins. Binding fatty acids to a protein prevents micelle formation and disruption of the cell, as micelles act as detergents. The process of fatty acid uptake is rapid, reversible and independent of an energy supply (Spector, 1971). Increased work by perfused heart diminishes the internal concentration and speeds uptake (Oram *et al.*, 1973). The equilibria are presumably continuously displaced by metabolism, so that fatty acids passively enter cells down a concentration gradient. There is no difference in the fatty acid uptake rates in diabetic and normal skeletal muscle and the concentration of triacylglycerol in streptozotocin-diabetic soleus and normal muscle is related to the plasma concentration of FFA (Stearns *et al.*, 1979). Uptake of fatty acids by cultured muscle cells was rapid and dependent upon exogenous fatty acid concentration (Sauro and Strickland, 1987).

Uptake of plasma triacylglycerol. Direct uptake of plasma triacylglycerol into heart muscle triacylglycerol upon perfusion was not detected by Kreisberg (1966). However, significant uptake in L6 myocytes was found after 4h incubation with exogenous triacylglycerol (Shillabeer *et al.*, 1995). Standl *et al.* (1980) found that triacylglycerol concentration in plasma correlated with triacylglycerol concentration in skeletal muscle and with the variation of the triacylglycerol concentrations in both diabetic and normal skeletal muscle.

Transport of esterified fatty acids as VLDL. The supply of fatty acids to muscle, from this source is dependent upon the plasma concentration of VLDL and the activity of lipoprotein lipase. VLDL synthesis and secretion by liver is increased when the flow of fatty acids to the liver increases. There is evidence for a VLDL receptor (Takahashi *et al.*, 1992) and mRNA for it, is found in abundance in skeletal muscle (Sakai *et al.*, 1994). Its relevance to the regulation of the supply of fatty acids is unlikely as mutant strains lacking this receptor have normal plasma triacylglycerol levels. LPL is located at the luminal surface of capillary endothelial cells where it

catalyses the breakdown of VLDL triacylglycerol to fatty acids and monoacylglycerol for tissue utilisation. LPL activity has been found in a variety of tissue but in general the highest transcription rates and catalytic activities are in adipose tissue, heart and mammary gland.

Regulation of lipoprotein lipase activity. The regulation of LPL is reviewed by Braun and Severson (1992). The activity of LPL has been found to be regulated by a number of mechanisms and allows plasma fatty acids to be directed toward certain tissues and away from others depending upon relative demands. LPL activity has been shown to be altered during the period of development (Semenkovich *et al.*, 1989; Tavangar *et al.*, 1992), by fasting (Borensztajn and Robinson, 1970; Semb and Olivecrona, 1986; Doolittle *et al.*, 1990), by cold exposure (brown adipose tissue) (Carenheim *et al.*, 1988; Giralt *et al.*, 1990), during lactation in the mammary gland (Hamonsh and Hamonsh, 1983; Jensen *et al.*, 1991) and in obesity (Eckel, 1989; Fried *et al.*, 1991) and diabetes (O'Looney *et al.*, 1983). The specific activity of LPL is increased by the co-factor apolipoprotein CII (Garfinkel and Schotz, 1987; Wang *et al.*, 1992), and apolipoprotein VLDL-II inhibits CII stimulation (Schnieder *et al.*, 1990).

LPL is synthesised, undergoes post translation modification by N-glycosylation (Camps *et al.*, 1990), and is stored as an oligomer (Rose and Doms, 1988). Trimming of terminal glucose residues in the oligosaccharide chains attached to the LPL protein results in the acquisition of catalytic activity in the endoplasmic reticulum (Iverius and Ostlund-Lindqvist, 1967; Garfinkel *et al.*, 1983). The mechanism of this effect may be to induce separation of the oligomeric forms and dimerisation which is catalytically active (Iverius and Ostlund-Lindqvist, 1976; Garfinkel *et al.*, 1983). Fully processed LPL is then directed to the degradative pathway in lysosomes or translocated, by unknown mechanisms, to functional heparan sulphate proteoglycan binding sites on the luminal surface of the capillary endothelium. Pulse-chase experiments show that turnover of LPL is rapid in adipocytes (Cupp *et al.*, 1987; Vannier and Ailhaud, 1989) and in myocytes (Liu and Olivecrona, 1991).

Fasting has reciprocal effects in adipose tissue and heart. Fasting decreased the activity of LPL in adipose tissue (Semb and Olivecrona, 1989) and increased it (after 24h) in rat heart. Glucose refeeding rapidly increased LPL activity in adipocytes (Semb and Olivecrona, 1986). The mechanism of fasting in heart is by increased synthesis, and in adipose tissue by a decrease

in its specific activity (Dolittle *et al.*, 1990) possibly by diverting activated LPL to lysosomes. Decreased LPL activity in human adipose tissue, was found in diabetes associated with hypertriacylglycerolaemia (Chen *et al.*, 1980) and is probably the result of a decrease in the degradation of circulating VLDL (O'Looney *et al.*, 1983). Insulin increased immunodetectable LPL on the surface of adipocytes (Ailaud, 1990), enhanced synthesis and secretion (Spooner *et al.*, 1979; Chan *et al.*, 1988; Pradines-Fiugeres *et al.*, 1988) rates of LPL synthesis and mRNA levels (Ong *et al.*, 1988; Speake *et al.*, 1985; Reynolds *et al.*, 1990), but not gene transcription (Reynolds *et al.*, 1990). Insulin deficient diabetes resulted in a decreased degradation of VLDL by perfused hearts and decreased function LPL activity (O'Looney *et al.*, 1983). Administration of insulin *in vivo* rapidly reversed the effects of diabetes *in vitro* (Braun and Severson, 1991). However, incubations of control and diabetic cardiac myocyte preparations with insulin *in vitro* had no effect on LPL activities (Braun and Severson, 1992).

LPL activity in cardiac tissue is increased by starvation and obesity, and decreased in diabetes which shows that LPL activity may not be regulated by fatty acids.

Triacylglycerol synthesis enzymes. The traditional view of triacylglycerol synthesis is that there is no regulation and no flux generating step that would indicate a point of regulation. Incorporation of labelled exogenous fatty acid into triacylglycerol was extremely rapid in perfused rat heart and *in vivo* heart (Kako *et al.*, 1976). More recently studies have found that the triacylglycerol synthesis enzymes can be regulated by non-physiological and physiological means. Most information concerning the enzymes of triacylglycerol synthesis has been found using liver and adipose tissue. What is known of the regulation of lipolysis, in these tissues and in heart, is given below. The enzymes are glycerolphosphate acyltransferase (GPAT), 1-acylglycerolphosphate acyltransferase (MGAT), phosphatidate phosphatase (PAP), and diacylglycerol acyltransferase (DGAT).

GPAT is found in two forms. The mitochondrial form had a preference for acylate glycerol phosphate at position 1 and is very selective for saturated fatty acyl-CoA substrates (Monroy *et al.*, 1972; Monroy *et al.*, 1973). The other microsomal form, unlike the mitochondrial form, is totally inhibited by thiol-group reagents such as N-ethylmaleamide (NEM)

(Bates and Saggerson, 1979; Rider and Saggerson, 1983; Baht and Saggerson, 1988). In rat skeletal muscle it is found in the sarcoplasmic reticulum (SR) and has 80% of the specific activity of that found in liver (Cornell and MacLennan, 1985). The K_m of the microsomal GPAT form, in adipose tissue, is significantly less than K_m of the SR GPAT form in heart tissue. Glycerol phosphate concentrations in adipose tissue (Denton and Randle, 1967; Saggerson and Greenbaum, 1970), are generally well in excess of K_m , whereas in heart they are appreciably below or comparable to K_m (deGroot *et al.*, 1989; Trach *et al.*, 1986; Denton and Randle, 1967). GPAT (both forms), (PAP) and (DGAT) activities in adipocytes are decreased by catecholamines (Saggerson, 1985; Saggerson, Saggerson, 1988). GPAT is rapidly increased by insulin (del Carmen Vila and Farese, 1991; del Carmen Vila *et al.*, 1990; Farese *et al.*, 1994). GPAT may also be regulated by covalent modification by phosphorylation (which inactivates it) by an unidentified cyclic AMP independent protein kinase (Walsh *et al.*, 1989). Carbohydrate responsive sequences are located within -322 base pairs of the mGPAT promotor (Sniderman and Clinfore, 1994).

MGAT is mainly found in the endoplasmic reticulum in liver and adipose tissue.

PAP exists in two forms. In liver PAP2 is bound to the plasma membrane, is NEM-insensitive and its position in the membrane has prompted the suggestion that it has a role in signal transduction (Jamal *et al.*, 1991). PAP1 requires Mg^{2+} for activity and is totally inhibited by NEM (Jamal *et al.*, 1991). In liver and adipose tissue it is found in the cytosol and endoplasmic reticulum, and is translocated between these sites (Freeman and Mangiapane, 1989). It has been suggested that this compartmentalisation regulates its action, the more active form being at the membrane (Brindley, 1988). Interestingly, PAP translocation can be induced by increasing fatty acid supply (Brindley, 1988) and provide a mechanism of protection of the liver from the harmful effects of a large influx of fatty acids (Brindley, 1988; Brindley, 1984). In liver DGAT may be regulated by a cyclic AMP independent protein kinase (Haagsman *et al.*, 1982; Rodriguez *et al.*, 1992).

Information regarding regulation of triacylglycerol synthesis enzymes in heart is as follows
GPAT activity is decreased in regions made ischaemic by coronary artery occlusion (Heathers and

Brunt, 1985), possibly by a β -adrenergic mechanism mediated by protein kinase A (Heathers *et al.*, 1985), and reversed by reperfusion (Heathers and Brunt, 1985; Griffiths and Brunt, 1990). PAP (unspecified) and DGAT activity are increased in diabetes (Schoonderwoerd *et al.*, 1990). DGAT activity is decreased and PAP translocated by perfusion with glucagon. Mg^{2+} stimulated PAP activity has also been found in heart extracts (Schoonderwoerd *et al.*, 1990).

The triacylglycerol synthesis enzymes appear to be regulated by a number of means. In adipose tissue short term regulators include insulin (increase) and catecholamines (decrease). The specific activity of enzymes is regulated by phosphorylation and long term mechanisms such as protein synthesis. PAP and DGAT may be activated by fatty acids in adipose tissue and this also may be the means of activation of PAP and DGAT in heart with diabetes. An increase in PAP activity was also found with obesity in which levels of diacylglycerol were greater than normal controls (Saha *et al.*, 1994). The relevance to synthesis of enzymes in skeletal muscle is not known.

Triacylglycerol Breakdown

Acute regulation of triacylglycerol breakdown Lipolysis, in perfused hearts, has shown to be acutely regulated by a variety of factors. These are pressure development (Crass *et al.*, 1971); ischaemia or hypoxia (Brownsey and Brunt, 1977; Trach *et al.*, 1986; van Bilsen *et al.*, 1989), which may be secondary to the local release of catecholamines (Karwatowska-Krynska and Beresewicz, 1983), although there is evidence to the contrary (Crass, 1977; Crass and Pieper, 1975); factors that elevate cyclic AMP levels such as catecholamines (Kreisberg, 1966; Gartner and Vahouny, 1973; Crass *et al.*, 1975; Williamson, 1964; Christiansen *et al.*, 1969; Jestnok *et al.*, 1977; Hron *et al.*, 1977), glucagon (Schwartz *et al.*, 1993; Christiansen *et al.*, 1969; Jestnok *et al.*, 1977; Shipp *et al.*, 1972), methylxanthines and vasopressin acting through V1 receptors (Palazzo *et al.*, 1991). The concentration of calcium appears to be an important determinant of the lipolytic responses to hormones and is necessary for the stimulation of lipolysis by isoproterenol (Hron *et al.*, 1977; Schwartz *et al.*, 1993), glucagon (Schwartz *et al.*, 1993) or vasopressin (Palazzo *et al.*, 1991). Inhibition of lipolysis in perfused hearts is

effected by addition of exogenous fatty acids (Crass, 1977; Crass, 1972; Crass *et al.*, 1975; Saddik and Lopaschuk, 1994), acetoacetate and 3-hydroxybutyrate (Hron *et al.*, 1978). Insulin has been reported to have no antilipolytic effect in perfused hearts (Jungas and Ball, 1962).

Long term regulation of triacylglycerol breakdown The long term changes in lipolysis in adipose tissue have been well documented and that in cardiac tissue is given below. Rates of lipolysis, both basal and catecholamine stimulated, are increased in perfused hearts from diabetic or starved rats compared with that in normal rats (in several tissues Rösen and Reinauer, 1984; Denton and Randle, 1967; Saddik and Lopaschuk, 1994; Garland and Randle, 1964; Kreisberg, 1966). Isolated myocytes prepared from diabetic rats were found to have increased rates of basal and stimulated lipolysis (Larsen and Seversen, 1990; Myrmel *et al.*, 1992). Myocytes from normal rats, previously incubated with palmitate, oleate or ketone bodies have increased rates of lipolysis (Kryski *et al.*, 1985; Larsen and Seversen, 1990; Myrmel *et al.*, 1992). There is some evidence to the contrary. Paulson and Crass (1982) did not find an increase in the rate of lipolysis from perfused diabetic rat hearts. Kryski *et al.* (1985) have reported that lipolysis can be inhibited by exogenous fatty acids following incubation of myocytes with palmitate or oleate and glucose. As glycerol released from hydrolysis of triacylglycerol cannot be utilised by muscle cells, it has provided an effective means of measurement of triacylglycerol hydrolysis (Vaughan, 1961). Under the defined conditions of incubation, without exogenous fatty acids, it has been shown that there is a good stoichiometric relationship between glycerol output and the fall in the total triacylglycerol content, irrespective of the insulin status prior to isolation (normal Kryski *et al.* (1985) and diabetic Kenno and Severson (1985)).

The pathway of muscle triacylglycerol hydrolysis is given below.

Pathway of triacylglycerol hydrolysis



where I is lipase either hormone sensitive lipase or lipoprotein lipase

The cellular control of intramuscular triacylglycerol metabolism involves the action of lipase and the two major forms of lipase are lipoprotein lipase as described above and hormone sensitive lipase (HSL). HSL catalyses the rate-limiting step in the breakdown of triacylglycerol. It has a relatively broad substrate specificity and can hydrolyse tri-, di- and monoacylglycerols, cholesterol esters and small water-soluble substrates. As its name suggests HSL activity is regulated by hormones. The HSL most studied is that of adipose tissue from the rat and is reviewed by Yeaman *et al.* (1994). HSL has also been shown to be present in several other tissues, including heart and muscle (Small *et al.*, 1989, Holm *et al.*, 1987).

HSL is regulated by reversible phosphorylation. From a combination of work using isolated rat adipocytes and purified HSL, protein kinases and phosphatases, it has been established that there are two phosphorylation sites on the HSL polypeptide, which are phosphorylated *in vivo* and *in vitro* (Yeaman *et al.*, 1990, Strålfors *et al.*, 1984).

Site 1 (regulatory site) is responsible for the activation of HSL which occurs in response to lipolytic stimuli (Strålfors *et al.*, 1984). It has been shown that this site is phosphorylated by the cyclic AMP-dependent protein kinase (Strålfors and Belfrage, 1983, Garton *et al.*, 1988). In conjunction with cloning studies (Holm *et al.*, 1988) and phosphopeptide sequencing (Garton *et al.*, 1988) site 1 was identified as a serine residue at position 563 in the rat HSL sequence. The mechanism of increase in the rate of triacylglycerol hydrolysis by fatty acids *in vivo* may be an increase in the phosphorylation of site 1, the cyclic AMP dependent protein kinase stimulated by an increase in cyclic AMP. The fact that cyclic AMP levels in skeletal muscle from 48h starved rats is greater than that in fed rats (Stace *et al.*, 1992) provide an explanation for greater rates of lipolysis in skeletal muscle from starved rats. Also, smooth muscle cells, in culture, incubated with dibutyryl cyclic AMP, cholera toxin or methylisobutylxanthine showed a decrease in their triacylglycerol content (Terto *et al.*, 1990), and a 3-5 fold increase in triacylglycerol lipase activity (Palmer *et al.*, 1990).

Site 2 (basal site) is phosphorylated under basal conditions of lipolysis in adipocytes (Strålfors *et al.*, 1984). Several protein kinases have been shown to phosphorylate this site *in vitro*, and AMP-dependent protein kinase (AMPK) is thought to be the most likely candidate

under physiological conditions (Garton *et al.*, 1989). The basal phosphorylation site has been located at position 565 in the rat HSL sequence. An interesting observation resulting from mapping studies on HSL phosphorylated *in vitro* is that phosphorylation of site 1 blocks subsequent phosphorylation of site 2 and *vice versa* (Garton and Yeaman, 1990). The implication of this is that if site 2 is phosphorylated before site 1, then activation of HSL by site 1 phosphorylation is prevented. It has yet to be established whether this also occurs *in vivo*. It is not yet known which factors affect the phosphorylation state of site 2 and whether this state alter, either acutely or chronically.

Dephosphorylation of HSL is catalysed by protein phosphatases. Four classes protein phosphatase catalytic subunits account for most of the Ser/Thr phosphatase activity towards substrates so far examined (Cohen, 1989). There is evidence that activation of protein phosphatases may be involved in the anti-lipolytic effect of insulin (Strålfors and Honnor, 1989). Insulin appeared to inhibit triacylglycerol lipolysis in isolated skeletal muscle from diabetic and normal animals (Hopp and Palmer, 1991). Although no antilipolytic effect of insulin was found in perfused hearts.

The results above have not been found by all workers. One explanation for an increase in triacylglycerol concentration was the result of a decrease in lipolysis. The mechanism for the decrease is inhibition of HSL through the AMPK pathway. Evidence to support this comes from studies where adipocytes were incubated with the analogue of AMP, ZMP, which is produced by the monophosphorylation of 5-aminoimidazole-4-carboxyamine ribonucleoside (AICAR) (Sabina *et al.*, 1985; Corton *et al.*, 1995). The result was a rightwards shift in the isoproterenol dose response curves for activation of lipolysis (Sullivan *et al.*, 1994; Weekes *et al.*, 1994). Other evidence includes the finding that in crude preparations that submicromolar concentrations of palmitoyl-CoA activated AMPK (Carling *et al.*, 1987; Davies *et al.*, 1989). HSL is also inhibited by 0.1 μ M-oleoyl-CoA (Jepson and Yeaman, 1992). It is thought that this feedback inhibition has a protective effect by preventing the accumulation of free fatty acids in cells. In adipose tissue and liver, the gene expression was elevated after 2 days fasting, but fasting did not increase gene expression in skeletal muscle (Liu *et al.*, 1995).

Turnover studies show that triacylglycerol synthesis and hydrolysis function simultaneously. The turnover of triacylglycerol in myocardium is as much as 2%/min and incubation of cardiac myocytes with exogenous fatty acids show that turnover rates vary between 12 to 80%/h.. In normal fed man it was found 70% of administered ^{13}C triolein was oxidised in the first 6h and that lipid stores were spared (Binnert *et al.*, 1996).

There appear to be two phases in regulation of triacylglycerol concentrations in starvation, diabetes and high fat diets. In the acute phase during the development of diabetes or in the early stages of starvation, and with high fat diets, synthesis is increased by the supply of exogenous fatty acids in the forms of FFA or esterified in lipoproteins; these are increased by these conditions. PAP by translocation to its active form in the membrane. Hydrolysis is initially maintained at a basal level of activity by phosphorylation of site 2 of HSL in response to increased fatty acyl-CoA through the AMPK pathway. An increase in fatty acyl-CoA has been detected with starvation and diabetes *in vivo*, and perfusion of normal fed hearts with fatty acids *in vitro*. Short term effects of a rise in plasma fatty acids include inhibition of the PDH complex by the products of fatty acid oxidation. The initial inhibition of HSL could explain increased triacylglycerol in muscle and is supported by the results of incubation of cardiac myocytes where inhibition of HSL was detected after 1h of incubation with fatty acids. In the longer term, site 2 of HSL may be dephosphorylated thus removing the phosphate maintaining basal activity and site 1 is then phosphorylated thus activating HSL by cAMP dependent protein kinases. The levels of cAMP are known to be increased in starvation (Stace *et al.*, 1992). Synthesis enzymes are thus induced. The mechanism of increased enzyme activity, in diabetes, may be through the increase in fatty acids stimulated by the condition and not by glucagon as this hormone decreased PAP and DGAT in perfused hearts.

There is little information concerning the factors that regulate the concentration of triacylglycerol in skeletal muscle, perhaps because its concentration is small relative to deposits elsewhere. However, skeletal muscle is the major site for glucose sparing and the switch to fatty acid metabolism is therefore particularly important in this tissue during carbohydrate deprivation such as starvation or low carbohydrate diets, diabetes and also with high fat diets. Skeletal

muscle has been shown to have an active triacylglycerol metabolism and that it is altered in these conditions. As the supply of fatty acids to the muscle, is also increased by these conditions, the glucose fatty acid cycle may operate in skeletal muscle both in the whole body response and at the local level within the tissue itself. Studies to determine the long term factors affecting triacylglycerol metabolism were not permitted because no long term *in vitro* muscle culture existed. In this laboratory Stace *et al.* (1990) developed a muscle culture system using soleus muscle strips incubated under defined conditions. Using this system, an attempt was made to reproduce the effects of starvation, diabetes or high fat diets mediated by long term exposure of normal fed muscle to FFA, in order to define the mechanism(s) of regulation of triacylglycerol metabolism.

The results of the studies presented in this chapter were to include measurements of synthesis rates by incorporation of [³H] labelled fatty acids, and incubation with adenosine deaminase, or 8-phenyltheophylline, and net change by direct measurement of triacylglycerol concentration. Incorporation of fatty acids was demonstrated. Methods of measurement of triacylglycerol have been developed based on glycerol assay after hydrolysis of triacylglycerol. Most methodologies of hydrolysis have been developed for use with samples of human plasma (for a review see Klotsch and McNamara, 1990). There are two general methods; enzymatic using lipases in suspension and chemical using ethanolic solutions at a high pH following extraction with strong organic solvents. The advantage of the enzymatic procedures are that the hydrolysis media are compatible with glycerol assay reagents, that is, samples of hydrolysate could be transferred into the glycerol assay and are therefore simpler. Lipases available are specific for different acyl-glycerols and do not hydrolyse phospholipids. However, these methods were developed for use with plasma where triacylglycerol exists in a quasi-solution and it is necessary for the triacylglycerol to be present in the form of an emulsion (Yamaguchi *et al.*, 1972). Lipase activity is proportional to the size of the emulsion particle (Sarda and Desnuelle, 1958). Muscle triacylglycerol is neither accessible to lipases nor present in solution. Chemical methods include silicic acid chromatography separation of glyceride species followed by saponification with ethanolic KOH (Denton and Randle, 1967) and hydrolysis using tetraethylammonium hydroxide which specifically cleaves triacylglycerol (Chernick, 1969).

Variations on enzymatic and chemical methods for use with muscle triacylglycerol were investigated. The extraction process was monitored using radiolabelled triacylglycerol and recoveries were >95%. All methods in experiments were internally consistent (standard errors were <5% of mean values). However, variation in the content of triacylglycerol in individual muscle strips was so great that it seemed unlikely that useful data about the regulation of triacylglycerol concentration could be obtained with this preparation.

MATERIALS and METHODS

1 Materials

All chemicals were of the highest grade available and purchased from BDH Merck Ltd, Hunter Boulevard, Magna Park, Lutterworth, Leics LE17 4XN. These were celite, chloroform, glycerol, KCl, KOH, MgCl₂, silicic acid, Norit 95X (activated charcoal), dimethylsulphoxide (DMSO), triethanolamine (TEA), H₂SO₄, HCl, NaOH, NaHCO₃, MgSO₄, n-heptane, hexane, bovine serum albumin, methylated spirit, rotenone, potassium cyanide, 8-anilino naphthelene sulphonic acid, isopropanol diether, glacial acetic acid, petroleum spirit and diethyl ether. Opti-fluor® (high flash-point liquid scintillation cocktail for aqueous and nonaqueous samples) was supplied from Packard Instrument Co Inc, 2200 Warrenville Road, Downers Grove, Illinois USA.

Biochemicals were obtained from Sigma Chemical Company Ltd, Fancy Road, Poole, Dorset BH17 7BR UK. These were antibiotic-antimycotic solution (100x), glycerokinase (from *Candida mycoderma*), L-Lactate dehydrogenase (Type II from rabbit muscle), 8-phenyltheophylline, phosphoenolpyruvate (2-[phosphonoxy]-2-propenoic acid, Tris cyclohexylammonium salt), adenosine triphosphate (disodium salt), phosphatidyl serine L- α - (1,2-Diacyl-sn-glycero-3-phospho-L-serine from bovine brain and was kept in chloroform-methanol 95:5), pyruvate kinase (Type II from rabbit muscle), tetraethylammonium hydroxide 20% aqueous solution, Triolein a commercially prepared triacylglycerol standard 3.388mM in saline with surfactants and 0.1%-sodium azide as a preservative, lipase from *Rhizopus arrhizus* and came as a suspension with ammonium sulphate 400 000U/mg protein, α -chymotrypsin from bovine pancreas lyophilized powder 40-60U/mg protein and esterase from porcine liver was supplied in suspension in 3.2M-ammonium sulphate pH 8 and approx. activity was 200U/mg protein. From Boehringer Mannheim UK (Diagnostics and Biochemicals) Ltd, Bell Lane, Lewes, East Sussex BN7 1LG was purchased β -NADH (disodium salt), adenosine deaminase (from calf intestine, in suspension at 1000U/ml in 3.2M-ammonium sulphate). Medium 199 Earle's salts was bought from Gibco Life Technologies Ltd, PO Box 35, 3 Foundation Drive,

Inchinnan Business Park, Paisley. (see Appendix 1 for details of the composition). The anaesthetic used to sedate rats was Sagatal™ (Sagatal-pentobarbitone sodium B.P. (Vet.) 60mg/ml) from Vet Drug Limited, Unit 8, Lakeside Ind Estate, Colnbrook by-pass, Colnbrook, Slough SL3 OED. Pure olive oil of the highest quality (calculated concentration was 0.898M) as purchased from a local retailer. Lipase from *Chromobacterium viscosum* lyophilized powder 3400U/mg was supplied by Calbiochem Novabiochem, 3 Heathcoat Building, Highfields Science Park, University Boulevard, Nottingham NG7 2QT.

Radiochemicals were from Amersham International, Amersham Place, Little Chalfont, Bucks. HP7 9BR and these were 2MBq of glycerol tri [1-¹⁴C] palmitate toluene solution (1.85-2.2GBq/mmol), and 37MBq of palmitic acid [9,10(n)-³H] in ethanol (1.5-2.2TBq/mmol). Boehringer Mannheim UK. All chemical, biochemicals and radioactive chemicals were stored according to the manufactures' instructions. Whatman no 540 filter paper, 3MM paper and thin layer chromatography plates 60A K6 (10cm x 20cm glass plates covered with a 250µm layer of silica) were supplied by Whatman Ltd., Springfield Mill, Maidstone, Kent, UK. 0.22µm filters were supplied by Millex-GV, Millipore.

2 Solutions

Stock solutions were prepared using double distilled water and stored in glass bottles at 4°C. Incubation solutions include Krebs-Henseleit (1932) buffer 120mM-NaCl, 25mM-NaHCO₃, 5mM-KCl, 1.2mM-KH₂PO₄, 1.2mM-MgSO₄, and 2mM-CaCl₂. Bovine serum albumin (BSA) was defatted and a proportion loaded with palmitic acid and radioactive palmitic acid, and the details of these preparations are given below in a separate section. 3mM-8-phenyltheophylline solution was made with DMSO (with warming) and diluted with Medium 199 to final concentrations used in experiments. Stock solution of adenosine deaminase (1000U/ml) was diluted to 0.5U/ml final concentration with Medium 199. The above incubation solutions were freshly prepared for each experiment. The triacylglycerol extraction solutions were chloroform-methanol (2:1, v/v) and contained glycerol tri [¹⁴C] palmitate at a concentration of 200dpm of stock /1ml-chloroform-methanol mix and was stored at -20°C; stock solutions of

50mM-NaHCO₃ made with 50% aqueous ethanol and 4mM-MgCl₂ were stored at 4°C. Triacylglycerol was chemically hydrolysed with either tetraethylammonium hydroxide (stock 20%) diluted 1:1 (or 0.68mM) with absolute ethanol on the day of use; or alcoholic 4%-KOH made with 95%-aqueous ethanol; or by enzymatic means *C. viscosum* lipase which was put into suspension by homogenisation using a eppendorf homogeniser and 3.4M-ammonium sulphate to a concentration of 100U/μl. Standard triacylglycerol solutions included an olive oil emulsion made by adding 1μl of pure olive oil to 1ml of absolute ethanol and mixed by vortex. The concentration was calculated to be 0.898mM triacylglycerol. The glycerol assay solutions were made as follows. Glycerol assay buffer or 0.1M-triethanolamine (TEA) was diluted from stock TEA with double distilled water, the pH adjusted to 7.6, and stored at 4°C. On the day of use the following additions to the TEA solution were made and these were final concentrations of 6mM-MgSO₄, 2mM-KCl, 7mM-PEP, 1.875mM-ATP. Fresh 20mM-NADH stock solution was made for each days analyses. A standard glycerol solution was made 2mM (w/v in water). 1mM-Rotenone stock solution was made with DMSO and 154mM-potassium cyanide stock solution was made with water and stored at -20°C. Solutions for thin layer chromatography were made as follows. Buffer 1 contained isopropyl diether: glacial acetic acid (94:6) and buffer 2 40°C-60°C petroleum spirit: diethyl ether: glacial acetic acid (90:9:1). Bradford reagent for measuring protein concentration was made according to that described in Bradford (1976).

3 Preparation of bovine serum albumin bound with palmitic acid and ³H palmitic acid

Stock 8.5%-bovine serum albumin (BSA) solution. BSA was defatted using a method based on that described by Chen (1967). 100g BSA was dissolved in 970ml distilled water. 50g Norit 95X (activated charcoal) was then added and stirred for 1h at room temperature. The pH was lowered to pH 3.0 with 6N-HCl and stirred again for 1h at 8°C. The mixture was centrifuged at 10 000g for 1.5h at 2°C (MSE 75: 6x300ml fixed angle rotor). The supernatant was pipetted into a fresh beaker and neutralised with 5N-NaOH using a glass electrode. The mixture was filtered under a vacuum through a 0.5cm deep layer of celite supported by filter

paper on a Buchner funnel, and then the celite was washed with water. The filtrate was dialysed against water overnight. The dialysate was shell frozen in a round round bottomed flask using liquid nitrogen and lyophilized using a lyophilizer (Unitrap II, Virtis Gardiner, New York). The resulting powder was stored at -20°C .

Stock 280mM-palmitic acid solution. A stock solution of 280mM-sodium palmitate was made in 34% (v/v) aqueous ethanol and the solid dissolved by heating to 60°C . The solution was stored at 4°C . A solution of 10%-BSA was made in Krebs-Henseleit buffer (KHB) as follows. Incomplete KHB was made without Ca^{2+} solution and was stirred slowly. BSA was added slowly and carefully to prevent bubbles forming which would denature the protein.

Stock 8.5%-BSA 6mM-palmitic acid solution. The 280mM-palmitic acid solution was heated to 60°C . With the BSA solution stirring vigorously and heated to 40°C using a stirring and heating unit, the palmitic acid solution was quickly added using a hot glass pipette with the end of the pipette held just below the surface of the BSA solution. The final concentration of the BSA-palmitic acid solution was 6mM after the addition of radioactive palmitic acid and the remaining component of the KHB (*i.e.* CaCl_2 solution).

Stock 8.5%-BSA 6mM-palmitic acid [^3H]-palmitic acid solution. Palmitic acid [$9,10(n)-^3\text{H}$] was added to the BSA-palmitic acid solution to a concentration of 3500dpm/ml. The Ca^{2+} solution was added and the BSA solution dialysed against complete KHB for 36h. The solution was then centrifuged (MSE18; 10 000g, 30min, 4°C) and the supernatant, under sterile conditions (laminar flow cabinet), was passed through a $0.22\mu\text{m}$ filter (Millex-GV, Millipore) into a sterile container. The resulting solution was stored frozen at -20°C . On the day of use solutions were thawed (gently in a water bath set at 30°C) and added to KHB to final concentrations 0.85%-BSA, 0.6mM-palmitic acid and 350dpm/nmol ^3H palmitic acid before incubating with muscle strips.

Control BSA solutions were made in exactly the same way but 34% aqueous ethanol was substituted for the palmitic acid solution.

4 Rats

Male albino Wistar rats weighing 150-200g were supplied by Harlan Olac, Shaw's Farm, Blackthorn, Bicester, Oxfordshire OX6 0TP. Rats arrived weighing 50-75g each and were used after a settling in period of three weeks in the Departmental animal house with free access to food ('Aged rat and mouse diet' from Bantin and Kingham Limited, The Field Station, Grimston Aldbrough Hull, N. Humberside HU11 4QE) and water. Starved rats (48h) were deprived of food but had free access to water.

5 Sterility

Sterility at all stages of experiments where muscle strips were cultured was not possible as this part of the experiment took place in the main laboratory and rats were not sterile. However, all equipment used in the preparation of soleus muscle strips was cleaned very thoroughly shortly before use. All solutions were handled with sterile equipment. Conical flasks (50ml) were prepared by soaking in 4M-H₂SO₄ overnight. They were then rinsed with distilled water and baked in an oven overnight at 180°C. Medium 199 was supplemented with 1% (final concentrations)-antibiotic-antimycotic solution which contained streptomycin (100mg/l), benzylpenicillin (60mg/l or 10⁵units/l) and amphotericin (250µg/l). Medium 199 also contains phenol red, a sensitive pH indicator, which allowed any infections or incorrect oxygen tensions to be easily detected.

6 Long term culture of soleus muscle strips *in vitro*

Preparation of rat soleus muscle strips. The preparation of soleus muscle strips was based on that of Crettaz *et al.* (1980). Before dissection rats were anaesthetised with an intraperitoneal injection of Sagatal™ (3ml/kg-body weight). Hindlimbs were removed, the skin washed with a little methylated spirit and removed and the skinned limb fixed to a polystyrene board using syringe needles, through the foot at one end and through the muscle mass at the other end so that the proximal (Achilles) tendon was uppermost. Using a pair of curved end forceps the Achilles tendon was lifted from the rest of the muscle mass, ligated and severed at the

ankle. Using the ligature the tendon was gently pulled up away from the distal tendon exposing the soleus muscle almost clear of the rest of the muscles. The soleus muscle was bisected as follows. The muscle was lifted to create a little tension using curved forceps and a new very fine syringe needle pierced the centre of the muscle and was gently pulled toward each end of the muscle. Great care was taken at this stage to ensure that damage to the muscle strip was minimised. The tendons at each end of each strip were ligated and cut away from the muscle mass. Using the ligatures muscle strips were tied to a stainless steel spring clips so that muscle strips were held in the spring clip under a little tension, one muscle strip per clip. This fixture of muscle strip to spring clip is described by Cuendet *et al.* (1976). Three of the four ligatures were cut to within 2cm of the knot, and the fourth was used to suspend the muscle strip in incubation medium (see later). Dissection and mounting of a muscle strip was done within 5min. Variation because of differences in the rats was minimised by incubating strips from the same animal in each condition.

Incubation of muscle strips. Mounted muscle strips were placed so that the muscle strip was suspended in medium by the longest ligature held by the rubber stopper and incubated in 50ml sterile conical flasks containing Medium 199. Medium 199 was prewarmed to 38°C, pre-equilibrated with O₂/CO₂ (95%:5%) for 30min, and supplemented with 1% (final concentration)-antibiotic-antimycotic solution. (For incorporation experiments medium containing the radioactivity was made as a large batch and then transferred to the individual flasks.) Flasks were placed in a shaking water bath (Gallenkamp, BSK-350) set at 110cycles/min, 38°C for up to 24h. Flasks were gased for 5min every 3h automatically using a timer switch that controlled the gas flow to the flasks. Gas was distributed to the flasks through a glass manifold.

Post incubation. After incubation muscle strips were cut away from the clip leaving tendons still attached, blotted very gently with filter paper (Whatman No. 540), wrapped in labelled foil and submerged in liquid nitrogen for instant freezing.

7 Measurement of skeletal muscle triacylglycerol

7.1 Triacylglycerol extraction

The extraction procedure used in experiments was adapted from the method of Folch *et al.* (1957). Each muscle strip was thawed and placed in a preweighed scintillation vial insert and weighed again for muscle weight. Muscle strip weights did not exceed 40mg. Each muscle strip was chopped with small scissors, 0.5ml of chloroform-methanol mix (2:1 (v/v)) added and poured into a glass thick walled test tube. The muscle strip was then homogenised using a motor driven polytron (Polytron homogeniser PT10-35) with a medium aggregate set at position 5 for 1min and poured into a second test tube. The scintillation vial insert was rinsed with 0.5ml chloroform/methanol mix and 1ml of chloroform/methanol was added to the homogenisation test tube to rinse the polytron probe and both washes were added to the second test tube. The homogenising test tube was rinsed with a further 1ml of chloroform/methanol and poured into the second test tube. This last step was repeated and the total volume of added extraction solution was 4ml. This process was carried out at 4°C (cold room) to minimise losses by evaporation and to decrease risk of fire. After extraction overnight at 4°C, samples were centrifuged (Mistral 6L; swing out rotor, 500g, 30min at 4°C). Muscle tissue floated on the top and was carefully removed. The remaining solution was removed to preweighed test tubes and the muscle tissue re-extracted by homogenising in 2ml of chloroform-methanol mix using the polytron homogeniser as before. After centrifuging (as above) and removing floating muscle tissue the two solutions were combined and the volumes determined gravimetrically given the density of the chloroform-methanol mix. Muscle tissue was removed and solutions were washed by adding 0.3vol of 4mM-MgCl₂ and shaking, and the two phases allowed to separate for 30min at 4°C. Samples were centrifuged as before. The top, aqueous layer was carefully removed using a Pasteur pipette. The lower, organic layer containing triacylglycerol was transferred to a glass test tube and the volume measured gravimetrically. The solvent was blown off with nitrogen gas. Samples were resuspended with heptane and washed with 50mM-NaHCO₃ in 50%-ethanol to remove extracted fatty acids, shaken and the aqueous layer aspirated and discarded. It was sufficient to repeat this step twice more as no radioactivity was found in the

washes after two washes of muscle extracts where muscles had been incubated with radiolabelled palmitic acid. Heptane was removed with nitrogen gas.

In control experiments where the KOH/OH method of enzyme hydrolysis was used, extraction included a further step. Dried down samples as above were resuspended using 6ml-chloroform and 0.5g-silicic acid that had previously been heated to 120°C overnight to drive off water, was added, shaken, and the sample allowed to stand for 5min on ice. Samples were centrifuged to pack the silicic acid (Mistral swing out rotor; 500g, 10min at 4°C) and the supernatant was carefully removed using a Pasteur pipette into a fresh tube and the solvent evaporated either by heating using a water bath set 65°C or by using gaseous nitrogen.

7.2 Methods of triacylglycerol hydrolysis

Chemical hydrolysis by the Tetraethylammonium hydroxide method. The method used to hydrolyse triacylglycerol concentration of muscle strips used in experiments was adapted from Chernick (1969). To each muscle strip extract (see section 7.1) was added 50µl of 0.68M-tetraethylammonium hydroxide in 50%-ethanol, mixed (vortex for 30s) and heated to 60°C (water bath) for 60min. 167µl of 0.2N-HCl was then added to neutralise the sample, the sample removed from the heat, mixed (vortex) for 30s and cooled to 4°C. Each sample was washed with 1.5ml of n-hexane to remove free fatty acids, mixed by shaking and the hexane layer removed with a Pasteur pipette. The concentration of triacylglycerol was determined in aliquots of the resulting solution that were assayed for glycerol (section 11).

Alternative methods of triacylglycerol hydrolysis were investigated and are given below. They were not used in experiments as the methods proved inconsistent or unacceptable losses were incurred.

Chemical hydrolysis by 4%-KOH in 95%-ethanol saponification. The method of 4%-KOH in 95%-ethanol saponification is described by Denton and Randle (1967). Extracted samples (see section 7.1) were resuspended with 0.5ml-4%-KOH in 95% ethanol, mixed (whirlimixer), incubated at 60°C for 30min (waterbath), and cooled to 4°C. 0.5ml cold 10%-PCA was added and centrifuged (Mistral 6L; swing out rotor; 500g, 10min at 4°C). The supernatant was aspirated using a Pasteur pipette into a fresh tube to which was added 0.25ml

saturated-KHCO₃, and centrifuged as before. Triacylglycerol concentrations were calculated from glycerol concentrations measured in glycerol assays (section 11) using aliquots of the supernatant solution.

Enzymatic hydrolysis using Chromobacterium viscosum or Rhizopus arrhizus. More recent methods of triacylglycerol hydrolysis, utilising lipases derived from bacteria, have been developed for use in industrial purposes or for routine clinical measurements of triacylglycerol in plasma. The methods of enzymatic triacylglycerol hydrolysis are reviewed in the introduction to this chapter. Lipases from two sources were investigated and were from *Rhizopus arrhizus* which was used with a pig liver esterase (Wahlefeld *et al.*, 1972) and *Chromobacterium viscosum* (Fossati and Prencipe, 1982). Glycerol assay buffer or 1.4ml of 0.1M-triethanolamine (pH 7.6) containing 6mM-MgSO₄/2mM-KCl/7mM-phosphoenolpyruvate/2mM-ATP was added to a cuvette followed by 100U of *C. viscosum* lipase or up to 400-U of *R. arrhizus* lipase (see results and discussion section), a triacylglycerol standard (triolein or olive oil) or sample of extracted muscle (see extraction procedure section 7.1), mixed using a small glass rod and incubated for 20min at 30°C (water bath). A sample of hydrolysis mixture was added to another cuvette containing 1.4ml of glycerol assay buffer and the remaining glycerol assay reagents (15µl of 20mM-NADH (final concentration 0.21mM), 5µl-pyruvate kinase (final concentration 5U/ml), 2µl-LDH (final concentration 5U/ml)), and mixed. The concentration of glycerol liberated from triacylglycerol was calculated according to the method given in section 11.

8 Recoveries of glycerol tri [1-¹⁴C] palmitate

The extraction process was monitored using glycerol tri [1-¹⁴C] palmitate added to chloroform-methanol mix (see solutions). Aliquots of the combined solutions from the extraction process (section 7.1) and the lower layer were added to scintillation fluid (Optifluor) and the radioactivity counted β-radioactive scintillation counter (Minaxi Tri-Carb 4000 series, Canberra Packard Limited, Brook House, 14 Station Road, Pangbourne, Berks). The overall percentage loss was calculated from the loss of radioactivity during extraction and the

concentration of triacylglycerol, measured by glycerol assay, adjusted accordingly. Recoveries were >95%.

9 Thin layer chromatography

To show into which lipid fraction tritiated palmitate was incorporated samples of extracted muscle were resuspended in chloroform and the lipids separated by thin layer chromatography which was visualised with 8-anilino naphthelene sulphonic acid under ultra violet light. Glass plates supporting silica gel were commercially prepared and were deeply scored to the glass to form lengthwise lanes. Up to 40 μ l of muscle extract and references (olive oil triacylglycerol standard in ethanol, palmitic acid in ethanol and phosphatidyl serine in 95%-chloroform/5%-methanol) were spotted at the origin and the solvent allowed to dry in air. The plates were then placed in a glass chromatography tank of suitable size. The tank was previously lined with 3MM Whatmann paper and the first buffer (94%-isopropanol diether and 6%-glacial acetic acid) added. When the buffer was equilibrated (*i.e.* reached the top of the paper) silica gel plates were placed inside the tank and the lid closed the tank. After 20min the solvent had reached half way. The plate was removed and dried under gaseous nitrogen. A second buffer (90%-petroleum spirit (40-60%), 10%-diethyl ether and 1%-glacial acetic acid) was equilibrated in the tank with a fresh piece of 3MM paper. The plate was placed again in the tank and after 20min the solvent front had reached 3/4 the way up the plate. The plate was removed from the tank and dried as before. The plate was then sprayed with 8-anilino-naphthelene sulphonic acid and visualised under UV light.

10 Simultaneous counting of ^{14}C and ^3H radioisotopes

In incorporation experiments both ^{14}C and ^3H isotopes were present in the same sample. The energy of a particle emitted from ^{14}C nuclei is greater than that from ^3H nuclei and the energy of the ^{14}C isotope may be sufficient to overlap with ^3H counting. To overcome this the radioactive counter was programmed such that the overlap was minimised. To test this programme a solution of similar radioactivity to that used in incubations was prepared and

counted. (50 μ l of glycerol tri [¹⁴C] palmitate in chloroform-methanol mix was added to 240 μ l of 0.85%-BSA-0.6mM-palmitic acid containing [³H] palmitic acid and the radioactivity contained was counted in samples of this mix.) A comparison was made with the individual isotopes counted using the same programme and no overlap was detected, counts from the hydrogen isotope were detected only in the appropriate channel and counts from the carbon source were only detected in its channel and not in the hydrogen channel.

11 Assay of glycerol

Glycerol was assayed according to the method by Garland and Randle (1962) which utilises the reaction sequence given below.

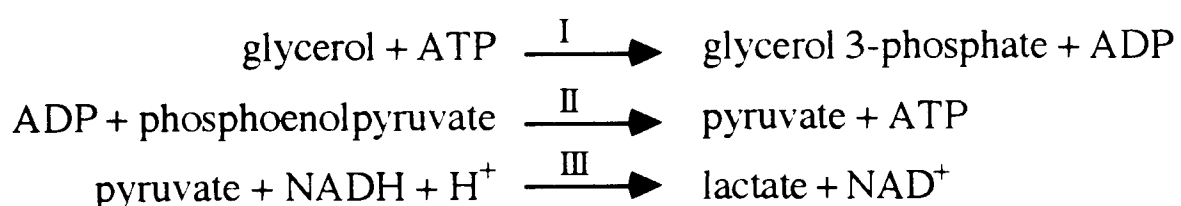

where I is glycerokinase, II is pyruvate kinase, and III is lactate dehydrogenase

The decrease in absorbance was measured as the concentration of NADH decreased at 340nm.

To a cuvette was added 1.4ml of 0.1M-triethanolamine (pH 7.6), containing 6mM-MgSO₄, 2mM-KCl, 7mM-phosphoenolpyruvate and 2mM-ATP, 15 μ l of 20mM-NADH (final concentration 0.21mM), 5 μ l-pyruvate kinase (final concentration 5U/ml), 2 μ l-LDH (final concentration 5U/ml), and up to 50 μ l of sample, mixed with a small glass rod and the absorbance measured using a Gilford Instruments UV/VIS spectrophotometer 250 and recorded with a chart recorder (Servoscribe Is RE 541.20 potentiometric recorder) set at 1cm/min and a full scale deflection of 2.0. When the trace indicated that the reaction had reached a steady state the absorbance was noted from the spectrophotometer. (This is a measure of any contaminating pyruvate or glycerol-3-phosphate.) To start the reaction 2 μ l glycerokinase (final concentration in assay 5U/ml) was added, mixed as before and when the reaction had reached a steady state any decrease in absorbance was noted. The assay was complete within 4min. The reaction was maintained at 30°C with water from the water bath. Absorbance readings were stable for at least

10min and even up to 60min there was only a very slight drift in the absorbance probably because the NADH at 30°C was decomposing.

From the absorbance difference and the millimolar extinction coefficient for NADH at 340nm of 6.22 cm^{-1} , the amount of glycerol in the added sample was calculated.

Before each day's analyses of glycerol concentration, standard glycerol solution (2mM) was used and recoveries were >95%.

12 Definition of enzyme activity

1 Unit of enzyme activity is defined as the amount required to convert 1 μmol of substrate to product in 1min at 30°C.

13 Expression of results and statistical analysis

Data are expressed as means \pm SEM together with the number of muscle incubations or the number of experiments given in parentheses. The results of identical experiments with different preparations were combined. The significance of differences between means was established by t-test using variance ratios to test for the significance of differences in variance between groups.

RESULTS

14 Development of protocols

Enzymatic hydrolysis

Methods utilising lipases were tested for suitability for hydrolysis with muscle triacylglycerol and specificity with respect to phospholipids. Two lipases commonly used (see Klotsch and McNamara, 1990) and extracted from bacterial sources were *Rhizopus arrhizus* in combination with chymotrypsin or esterase (Wahlefeld *et al.*, 1972) and from *Chromobacterium viscosum* (Bucolo and David, 1972). Reagents and buffers used with lipase hydrolysis methods were compatible with the glycerol assay and it was thought that the lipase method of triacylglycerol hydrolysis could be developed for use with muscle triacylglycerol, would be simpler and more efficient than traditional chemical methods and would be specific for triacylglycerol obviating the need for the silicic acid chromatography step used in traditional methods for removal of phospholipids before hydrolysis.

Triolein is used by many workers as a triacylglycerol standard (see Eggstein and Kuhlmann, 1974), is commercially prepared with surfactants to maintain the triacylglycerol in suspension and with preservative 0.1%-sodium azide. Before lipase hydrolysis, extracted muscle triacylglycerol with the extraction solvent removed was resuspended in solvents used by others and these were absolute ethanol (Eggstein and Kuhlmann, 1974); and isopropanol (Bucolo and David, 1973).

Figure 2.1 shows glycerol assay standard curve and that the recovery of glycerol from a standard glycerol solution was on average 90%, standard errors were <5% of their means and that the assay was linear and sufficiently sensitive to quantify accurately the concentration of glycerol from extracted hydrolysed triacylglycerol in the concentration range expected in muscle strips (10-80nmol). Chemical additives in Triolein, ethanol and isopropanol have little effect on the recovery of standard glycerol (on average $97\% \pm 2.7$) measured using the glycerol assay. Reports have described adding other agents to the glycerol assay in order to minimise interference by released fatty acids. These additions to the glycerol assay buffer were 0.2%-

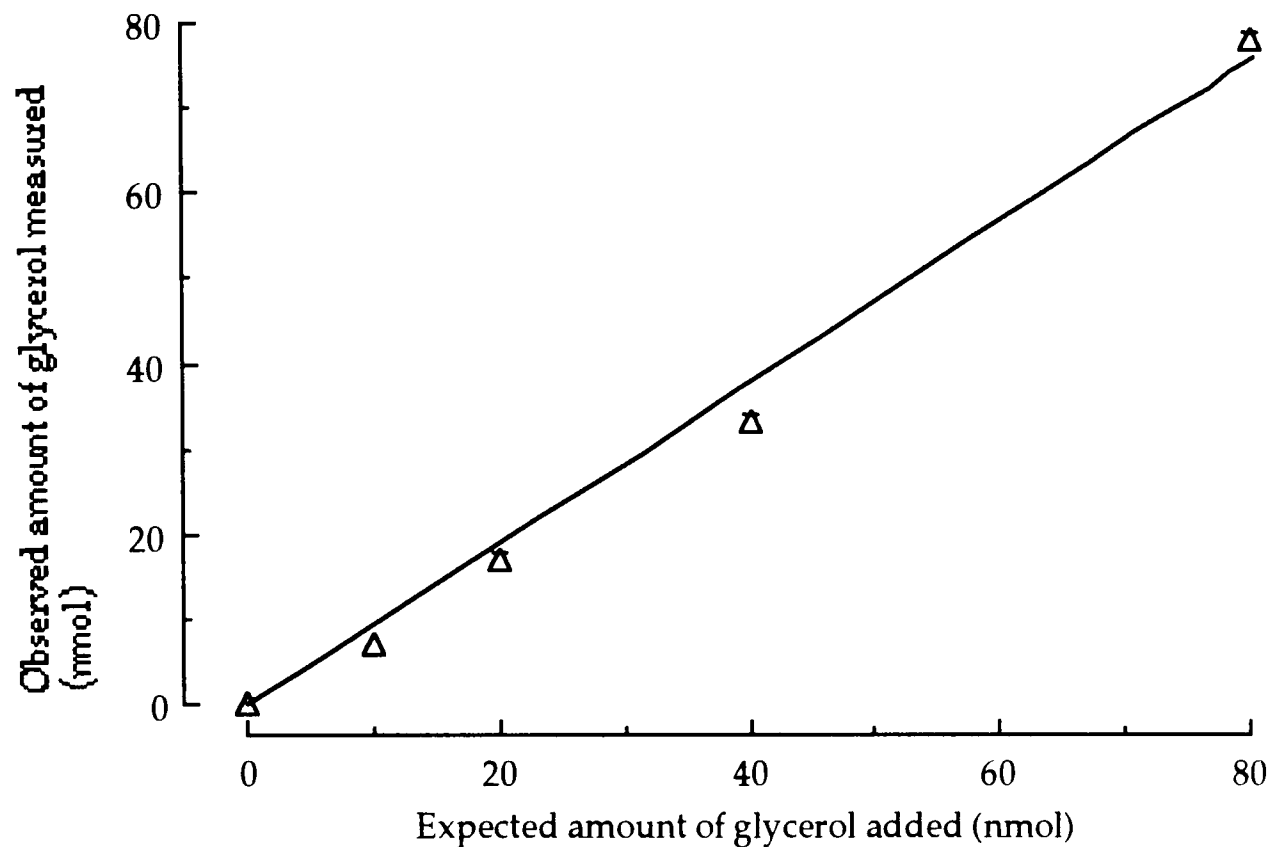
Figure 2.1 Glycerol assay standard curve

The concentration of glycerol in standard glycerol solutions was measured using the method described by Garland and Randle (1962) and given in section 11. A series of glycerol standard solutions were prepared using a 2mM-glycerol stock solution. A sample of each standard solution was added to a cuvette containing 1.4ml of 0.1M-triethanolamine (pH 7.6) containing 6mM-MgSO₄/ 2mM-KCl/ 7mM-phosphoenolpyruvate/ 2mM-ATP, 15 μ l of 20mM-NADH (final concentration 0.21mM), 5 μ l-pyruvate kinase (final concentration 5U/ml), 2 μ l-LDH (final concentration 5U/ml), and mixed with a small glass rod. The absorbance was measured using a spectrophotometer set at 340nm at 30°C (water bath). The concentration of glycerol was calculated from the absorbance difference before and after the addition of 2 μ l glycerokinase (final concentration in assay 5U/ml) given the millimolar extinction coefficient for NADH of 6.22cm⁻¹. The assay was complete within 4min. Data are expressed means \pm their SEMs for 3 observations at each concentration, and 'expected nmol' = the concentration of sample added to the cuvette and 'observed glycerol concentration nmol' = the concentration actually measured.

defatted BSA (w/v in water) (Megraw *et al.*, 1979, 0.13%; and Wahlefeld, 1972, 0.2%); 0.01%-Triton X-100 (w/v) (McGowan *et al.*, 1983; Fossati and Prencipe, 1982); 0.01%-SDS (w/v) (Wahlefeld, 1972); and 0.1%- α -cyclodextrin (w/v) (McGowan *et al.*, 1983) and did not effect the glycerol assay recovery of standard glycerol (on average $95\% \pm 3.2$).

Time courses for enzymatic hydrolyses of triacylglycerol standard. Figure 2.2 show progress curves for the hydrolysis in the glycerol assay. With *C. viscosum* lipase was complete by 20min incubation at 30°C, whereas that with *R. arrhizus* lipase in combination with esterase was not complete by 20min incubation at 30°C and was still not complete by 35min. The glycerol assay reagents with the latter mix of enzymes showed a drift equivalent to 1% of the recovery of glycerol from triolein and no drift was apparent with *C. viscosum* lipase incubation.

Concentration and combination of enzymes used to hydrolyse triacylglycerol standards.

The concentration of lipase from *C. viscosum* used has been variously reported; *e.g.* 250U/assay (Fossati and Prencipe, 1982); and 140U/assay (McGowan *et al.*, 1983). Many lipases have difficulty hydrolysing the fatty acid at the SN2 position. To facilitate this esterase or enzymes with esterase activity (chymotrypsin) had been added to increase the rate of glycerol liberation. The combinations were 400U-*R. arrhizus* lipase with 30U-chymotrypsin (Bucolo and David, 1972) or 30U-esterase (Wahlefeld *et al.*, 1972 56U/ml-lipase) or 0.1U-esterase (Megraw *et al.*, 1979), 4U-*R. arrhizus* lipase with 14U-esterase (Wahlefeld *et al.*, 1972 7.5U/ml), or 100, 200, 300 or 450U-*C. viscosum* lipase (Bucolo and David, 1973) alone. Figure 2.3 shows hydrolysis of standard triacylglycerol using the lipase from *R. arrhizus* was complete with only one combination of lipase and esterase out of four. Hydrolysis of Triolein was complete with the lipase from *C. viscosum*. On the basis of these results and that from the time course experiment *R. arrhizus* lipase was rejected in favour of 100U-*C. viscosum* lipase as a method of enzymatic triacylglycerol hydrolysis.

Solvent solutions for enzymatic hydrolysis of triacylglycerol standard. As lipase activity is dependent on emulsion particle size (Yamaguchi *et al.*, 1972) it was important to dissolve extracted muscle triacylglycerol (here olive oil was used) in a suitable solvent, that lipase activity was not affected by it and that the solvent was compatible with the glycerol assay. The effect of

Figure 2.2 Time course for the hydrolysis of triacylglycerol standards using 450U-*C. viscosum* and 165U-*R. arrhizus* lipases

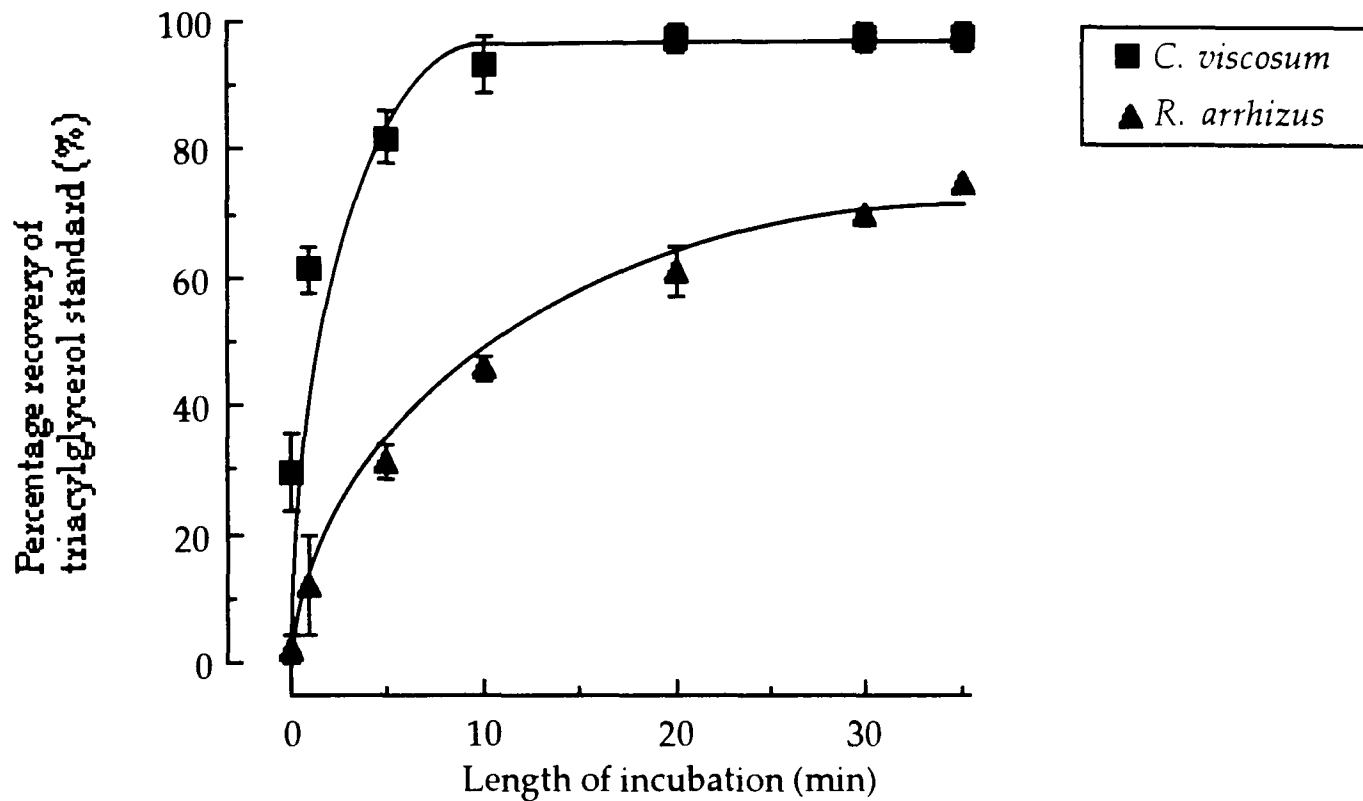

1.4ml of 0.1M-triethanolamine (pH 7.6) containing 6mM-MgSO₄/ 2mM-KCl/ 7mM-phosphoenolpyruvate/ 2mM-ATP, 15μl of 20mM-NADH (final concentration 0.21mM), 5μl-pyruvate kinase (final concentration 5U/ml), 2μl-LDH (final concentration 5U/ml), together with 33.88nmol-Triolein, were added to a cuvette and mixed with a small glass rod. The absorbance was measured using a spectrophotometer set at 340nm and the temperature maintained at 30°C (waterbath). 2μl-Glycerokinase (final concentration in assay 5U/ml) was added, mixed and the second absorbance noted. Then 450U-*C. viscosum* lipase or 165U-*R. arrhizus* lipase in combination with 15U-esterase were added to mixes and incubated for up to 35min. The percentage recovery of glycerol from Triolein was calculated from the absorbance differences before and after addition of lipase and glycerokinase and allowing for the drift in the assay with esterase and lipase from *R. arrhizus* given the millimolar extinction coefficient for NADH of 6.22cm⁻¹. Data are expressed as means ± SEMs for three hydrolyses runs each.

Figure 2.3 Concentration of *C. viscosum* and *R. arrhizus* and combination of *R. arrhizus* with esterase or chymotrypsin used in enzymatic hydrolysis of triacylglycerol standards

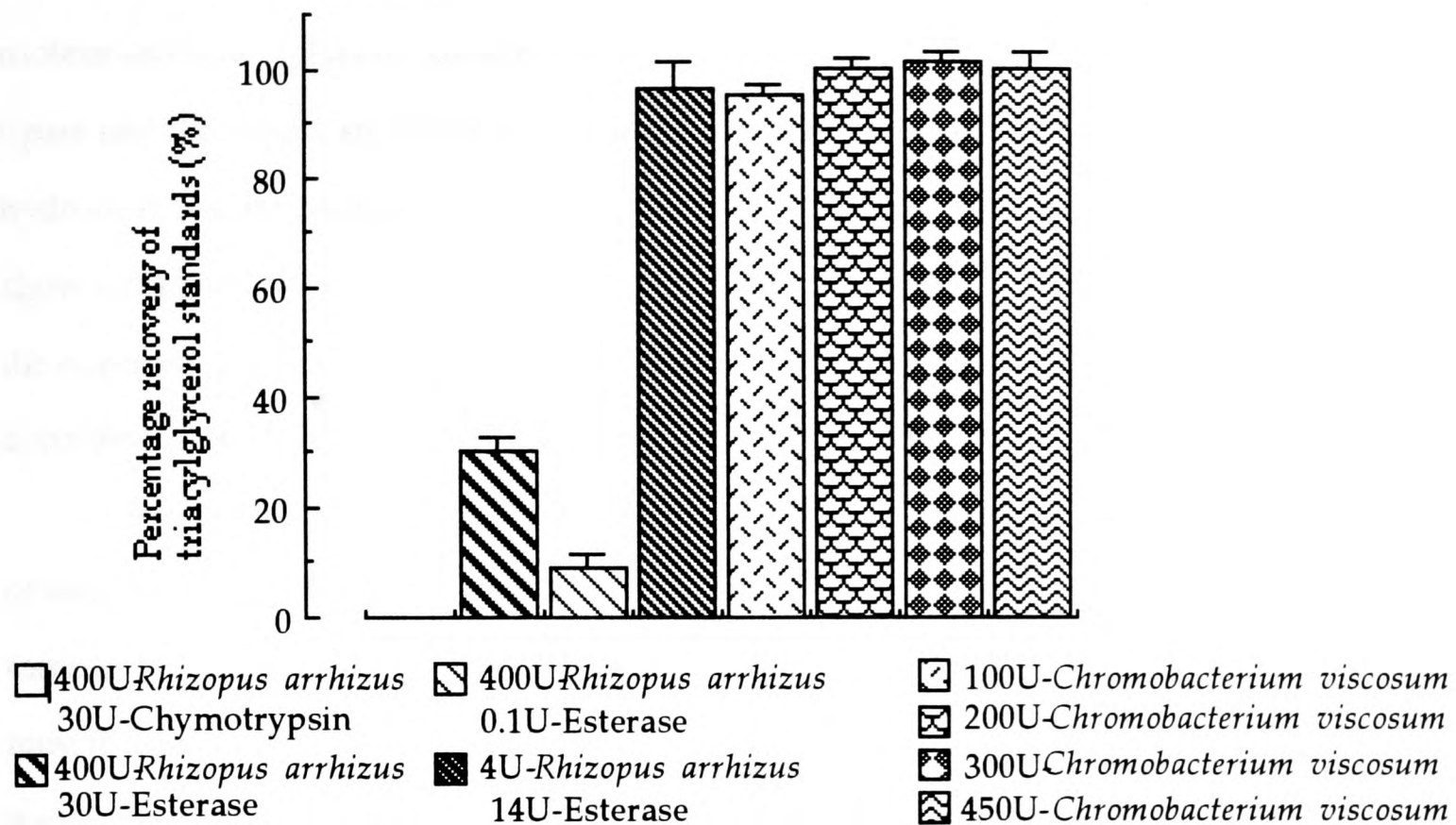

To 1.4ml of 0.1M-triethanolamine (pH 7.6) containing 6mM-MgSO₄/ 2mM-KCl/ 7mM-phosphoenolpyruvate/ 2mM-ATP with 0.2%-defatted BSA was added 400U-*Rhizopus arrhizus* lipase together with 30U-Chymotrypsin or 30U-Esterase or 0.1U-Esterase, or 4U-*Rhizopus arrhizus* lipase with 14U-Esterase, or 100, 200, 300 or 450U-*Chromobacterium viscosum* lipase and 33.88nmol-Triolein in a cuvette or 27nmol of olive oil in ethanol. The cuvette contents were mixed (with a small glass rod) and incubated for 20min for the *C. viscosum* lipase hydrolyses and 35min for the *R. arrhizus* lipase hydrolyses. Following this incubation the remaining glycerol assay reagents were added. These were 15μl of 20mM-NADH (final concentration 0.21mM), 5μl-pyruvate kinase (final concentration 5U/ml), 2μl-LDH (final concentration 5U/ml) and were mixed with a small glass rod. The absorbance was measured using a spectrophotometer set at 340nm and the temperature maintained at 30°C (waterbath). The concentration of glycerol was calculated from the absorbance difference before and after the addition of 2μl glycerokinase (final concentration in assay 5U/ml) given the millimolar extinction coefficient for NADH of 6.22cm⁻¹. Data are expressed as means ± SEMs for the percentage recovery of glycerol from hydrolysed triacylglycerol contained in Triolein combined with the results using olive oil, of at least 3 hydrolyses.

absolute ethanol (Eggstein and Kuhlmann, 1974), isopropanol (Bucolo and David, 1973), or 4%-Triton X-100 diluted with 0.9%-NaCl (Chang and McLaughlin, 1974) were tested with triolein and triacylglycerol standard olive oil. A sample of each solution was hydrolysed using lipase and the results are plotted in Figure 2.4. The results with 0.9%-NaCl show that either hydrolysis was incomplete or Triton X-100 interfered with the glycerol assay. Isopropanol show a slightly lower recovery than triacylglycerol standards - Triolein or olive oil in ethanol, in the expected glycerol concentration. 0.1%- α -cyclodextrin or 0.2%-defatted BSA were added according to the method and were used to bind released fatty acids.

Homogenisation of muscle strips directly into glycerol assay buffer for lipase hydrolysis of muscle triacylglycerol. As the conditions for enzymatic hydrolysis of triacylglycerol were the same as the glycerol assay buffer (0.1M-triethanolamine (pH 7.6)), homogenisation of the muscle directly into 0.1M-triethanolamine would provide an efficient means of triacylglycerol measurement without the need for prior solvent extraction. Approx. 30mg of muscle was homogenised (polytron, medium aggregate, position 5, 30 s) directly into 2ml of 0.1M-triethanolamine (pH 7.6) containing 6mM-MgSO₄, 2mM-KCl, 7mM-phosphoenolpyruvate and 2mM-ATP. After clarification by centrifugation (eppendorf centrifuge: room temperature, 13 000g, 2min) 30 μ l of supernatant was transferred to a cuvette with 1.4ml of 0.1M-triethanolamine (pH 7.6), containing 6mM-MgSO₄, 2mM-KCl, 7mM-phosphoenolpyruvate and 2mM-ATP and incubated with 100U-*C. viscosum* lipase at 30°C for 20min. The remaining glycerol assay reagents were added and immediately 15 μ l of 20mM-NADH (final concentration 0.21mM) was added the absorbance decreased and the change was 1.1 absorbance units. In second attempt the NADH stock solution was added after the addition of clarified muscle homogenate and the absorbance decreased by the same extent as before. The theoretical absorbance change with complete oxidation of the added NADH would have been 1.29 providing the solid had not deteriorated with storage. This indicated that the NADH was oxidised probably by NADH oxidases present in muscle tissue and now in suspension. To overcome this known NADH oxidase inhibitors (1mM-rotenone and 154mM-cyanide) were added to the cuvette (final concentrations were 10 μ M and 0.5mM respectively) containing 100U-

Figure 2.4 Solvent solutions for enzymatic hydrolysis of triacylglycerol standard

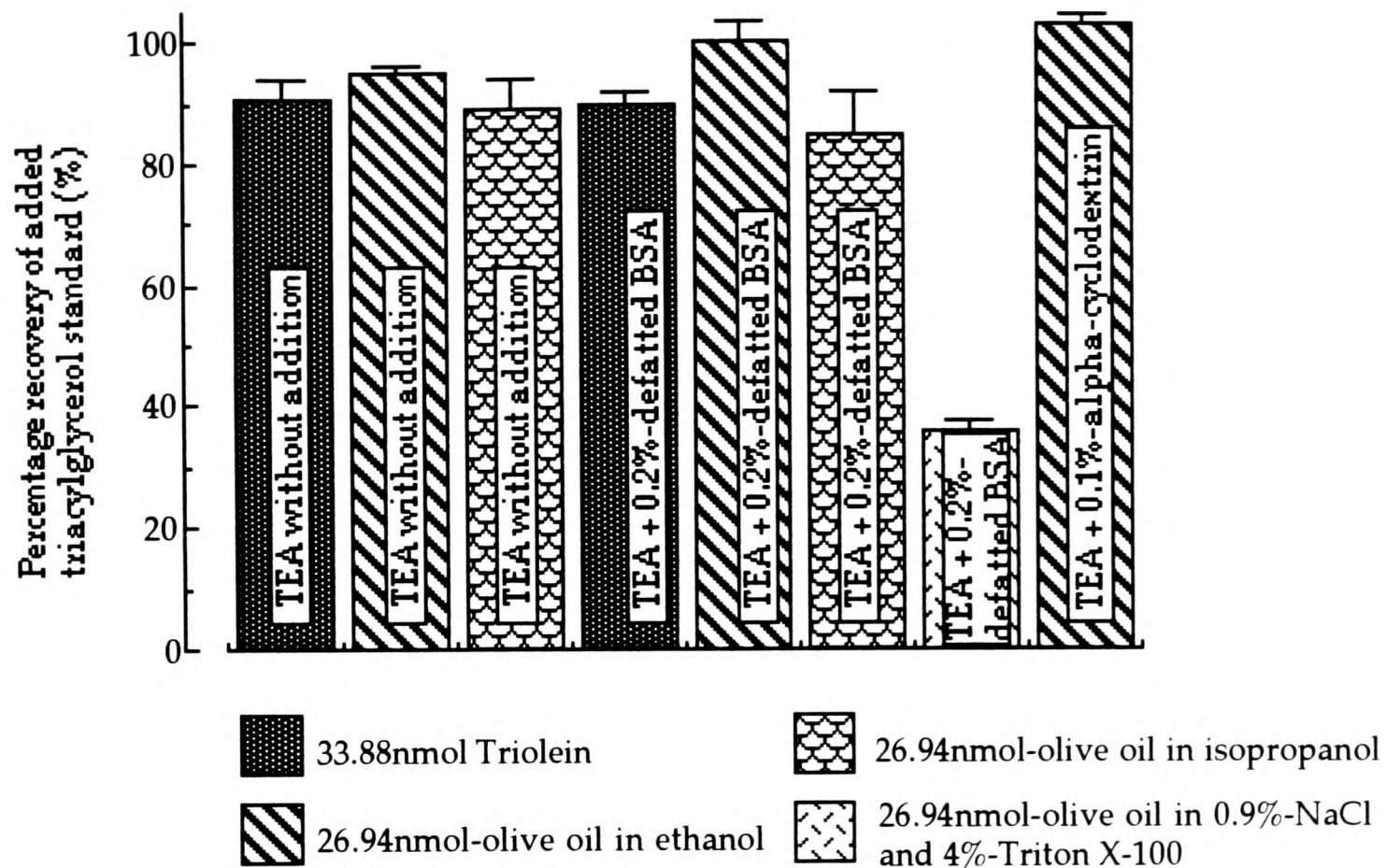

100U-*Chromobacterium viscosum* lipase was added to cuvettes containing 0.1M-triethanolamine (pH 7.6) (containing 6mM-MgSO₄/ 2mM-KCl/ 7mM-phosphoenolpyruvate/ 2mM-ATP) (TEA) or 0.1M-TEA with 0.2%-defatted BSA or with 0.1%-α-cyclodextrin and 26.94nmol-olive oil in absolute ethanol or in isopropanol or in 0.9%-NaCl containing 4%-Triton X-100 or 33.88nmol Triolein. The cuvette contents were mixed (small glass rod) and incubated at 30°C (waterbath) for 20min. Following this incubation the remaining glycerol assay reagents were added. These were 15μl of 20mM-NADH (final concentration 0.21mM), 5μl-pyruvate kinase (final concentration 5U/ml), 2μl-LDH (final concentration 5U/ml) and were mixed with a small glass rod. The absorbance was measured using a spectrophotometer set at 340nm and the temperature maintained at 30°C (waterbath). The concentration of glycerol was calculated from the absorbance difference before and after the addition of 2μl glycerokinase (final concentration in assay 5U/ml) given the millimolar extinction coefficient for NADH of 6.22cm⁻¹. Data are expressed as means ± SEMs for at least 3 hydrolyses.

C. viscosum lipase before addition of clarified muscle homogenate. The absorbance change (after glycerokinase was added) was 0.7. Given the likely concentration of triacylglycerol in 30mg of soleus muscle strip and the dilutions above, this change in absorbance is unlikely to be the result of the muscle triacylglycerol alone and may reflect other contaminants such as ATPases and not the triacylglycerol concentration.

Effect of temperature on enzymatic hydrolysis of triacylglycerol standards. If the contaminants found in clarified muscle homogenates made with glycerol assay buffer were proteins then possibly their effects could be nullified by heat denaturation. Yamaguchi *et al.* (1972) have reported that lipase from *C. viscosum* continues to function as effectively at higher temperatures up to 70°C with 65°C being the temperature for optimum lipase activity. To ensure that lipase did not itself denature with heating it was incubated at 65°C with triacylglycerol standards. 33.88nmol-Triolein or 27nmol-triacylglycerol standards were hydrolysed with 100U-*C. viscosum* lipase in 0.5ml of 0.1M-triethanolamine and incubated at 30°C, 37°C or 65°C using water baths. After 20min incubation 30µl samples of each were added to glycerol assays and the concentration of glycerol measured.

Recoveries of glycerol from triolein at 30°C was 94%±0.2 (n=3), at 37°C was 88%±2.4(n=3), and at 65°C was 89%±2.2(n=3) and for triacylglycerol standard at 65°C was 87%±6.6(n=3). The results show that the recovery of glycerol from hydrolysed triacylglycerol standards was incomplete. The obvious explanation is that the lipase is denatured by heating but this should not be the case as reported by Yamaguchi *et al.* (1972). Possibilities include the triethanolamine was in some way altered by heating or the triacylglycerol solvents were evaporated and emulsions were lost and the lipase unable to function as triacylglycerol must be in the correct emulsion for lipase activity.

Comparisons were made with chemical methods of hydrolysis using solvent extracted muscle triacylglycerol and the results of these and specificity tests are given together below.

Chemical methods of hydrolysis

Chemical hydrolysis of triacylglycerol standards. Hydrolysis of triacylglycerol standard

following chemical extraction (section 7.1) with the method employing 4%-KOH in 95%-ethanol (section 7.2) was $100\% \pm 5.2$ recovery of glycerol liberated, (n=9 assays from 3 separate extractions and with the method using 0.68M-tetraethylammonium hydroxide in 50%-ethanol gave $100\% \pm 3.1$ (15 assays from 5 extractions).

In a further test of the tetraethylammonium hydroxide method triacylglycerol standard was extracted with chloroform-methanol mix containing glycerol tri [^{14}C] palmitate tracer and dried down in aliquots that contained 27nmol of olive oil (approx. equivalent to that predicted in a soleus muscle strip). Extracted samples were resuspended with 50 μl of 0.68M-tetraethylammonium hydroxide in 50%-ethanol, mixed and the radioactivity in aliquots counted. The result was that $96\% \pm 3.2$ of the expected counts and 100% of expected glycerol concentrations were recovered.

Time course for chemical hydrolysis of muscle triacylglycerol by KOH/OH and tetraethylammonium hydroxide methods. Figure 2.5 shows that the optimum length of time for tetraethylammonium hydroxide hydrolysis of extracted soleus muscles was 60min and for KOH/OH hydrolysis was 30min.

Specificity of enzymatic and chemical methods of hydrolysis. It was vital that only glycerol released from triacylglycerol be measured and not that that may be liberated from phospholipid hydrolysis (e.g. in heart cardiolipin or diphosphatidyl glycerol). The method of hydrolysis must be specific for triacylglycerol and even if phospholipid is not hydrolysed by these methods they must not interfere in the process of hydrolysis (e.g. the presence of phospholipid must not inhibit triacylglycerol hydrolysis by competing with the active site of lipase). Therefore it was decided to test each hydrolysis method for triacylglycerol to the exclusion of phospholipid. Phosphatidyl serine was added at concentrations comparable to those expected of triacylglycerol in skeletal muscle and was subjected to the same treatments as triacylglycerol standards. Recoveries of glycerol from triacylglycerol and any that may have been liberated from phospholipid, by hydrolysis with lipase from *C. viscosum*, KOH/OH or tetraethylammonium hydroxide was assayed. The stock solution of phospholipid contained

Figure 2.5 Time course for tetraethylammonium hydroxide and 4%-KOH in 95% ethanol hydrolyses of extracted muscle triacylglycerol

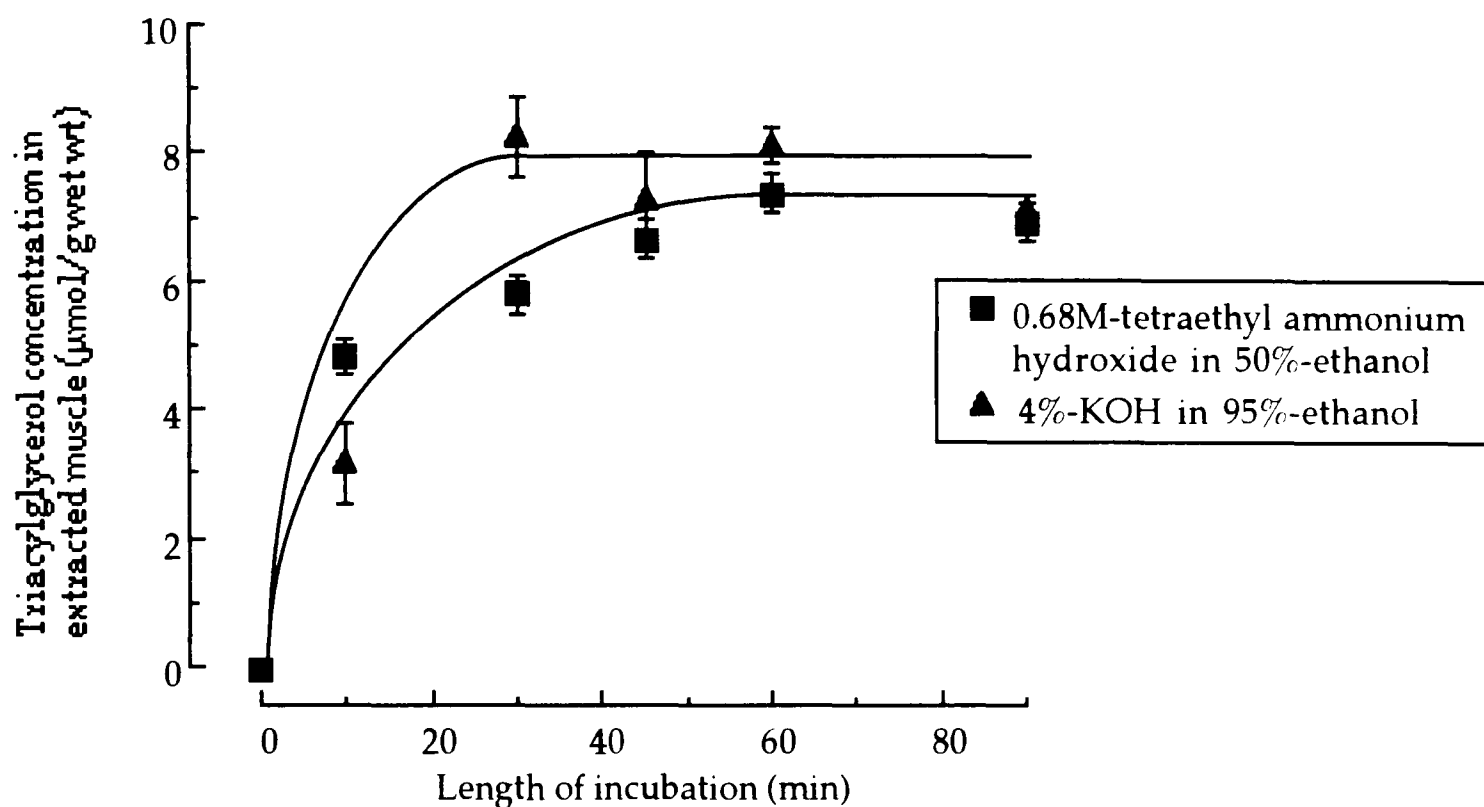

2.096g of mixed hindleg muscle was homogenised with 40ml or 20vol of ice-cold chloroform-methanol (2:1, v/v) using a polytron homogeniser (details are given in section 7.1). The aggregate was washed with a further vol of chloroform-methanol mix and allowed to extract overnight. The extract mix was centrifuged (Mistral 6L; 500g, 12min at 4°C) and the pellet homogenised as before, centrifuged as before, the muscle tissue removed and the two solutions combined. 3vol of 4mM-MgCl₂ was added, mixed and left on ice for 30min. The two phases were further separated by centrifugation as before and the upper aqueous layer aspirated and discarded. 0.6ml aliquots of the lower layer were pipetted into glass screw capped tubes and dried down using a hot water bath. To ten of the tubes was added 0.5ml 4%-KOH in 95%-ethanol and to another ten tubes was added 1ml of 0.68mM-tetraethylammonium hydroxide in 50%-ethanol, the tubes shaken and incubated at °C for up to 90min. Periodically samples were taken from the hydrolyses mixes and 0.5ml of 15%-PCA was added to KOH/OH hydrolyses and 1.2ml of 0.2M-HCl added to tetraethylammonium hydroxide hydrolyses. All tubes were mixed. KOH/OH were centrifuged as before and to the supernatant was added 0.25ml of sat. KHCO₃ and centrifuged again as before. The glycerol concentration was measured in 50µl aliquots using the glycerol assay (see section 11). For tetraethylammonium hydroxide hydrolyses after the addition of acid samples were cooled to 4°C and the fatty acids removed by adding 1.5ml of n-hexane, samples were then shaken and the hexane aspirated. Glycerol concentrations in samples were measured using the glycerol assay with 50µl aliquots. Data are expressed as means ±SEMs for 30 assays from 10 hydrolyses for KOH and 33 assays from 11 hydrolyses for the tetraethylammonium hydroxide method.

organic solvents (chloroform-methanol 95:5) and was evaporated before use. The possibility that the phospholipid interferes with hydrolysis or the glycerol assay was tested by incubating triacylglycerol standard together with the phospholipid.

Figure 2.6 shows the results of hydrolysis of phosphatidyl serine alone or in combination with triacylglycerol standard using *C. viscosum* lipase, 4%-KOH in 95%-ethanol and 0.68M-tetraethylammonium hydroxide in 50%-ethanol. In incubations containing phosphatidyl serine no hydrolysis of phospholipid was evident with *C. viscosum* lipase, -respectively 2% (with 0.68M-tetraethylammonium hydroxide in 50%-ethanol) and 9.1% (with 4%-KOH in 95%-ethanol) of the available glycerolipid. The 2% with 0.68M-tetraethylammonium hydroxide is within the error of the glycerol assay and was not significant. Competition between phospholipid and triacylglycerol was not evident with 0.68M-tetraethylammonium hydroxide (comparison of incubations of phospholipid and triacylglycerol standard with triacylglycerol standard alone. However, with *C. viscosum* lipase the concentration of glycerol released in these incubations showed that hydrolysis of triacylglycerol may have been incomplete because the recovery was not 100% as with incubations with triacylglycerol standard alone. Hydrolysis with 4%-KOH in 95%-ethanol liberated glycerol from both lipid species. Assuming that 100% of the triacylglycerol added was hydrolysed, then 42% of the glycerol measured must have come from hydrolysis of phospholipid which is normally overcome by silicic acid chromatography during extraction.

Homogenisation of skeletal muscle.

Traditionally, triacylglycerol is extracted from frozen powdered muscle by using a pestle and mortar under liquid nitrogen. Significant losses were incurred by this method and was certainly due to the very small amount of tissue (soleus muscle strips weighing approx. 30mg were powdered individually). The very small amount of tissue remaining made further processing difficult. Muscle strips were homogenised directly into extraction medium (chloroform-methanol (2:1, v/v) (Denton and Randle, 1967)) using a range of homogenisers. The polytron homogeniser (Polytron PT10) with a medium aggregate (with 'teeth') was the most

Figure 2.6 Specificity of *C. viscosum* lipase, tetraethylammonium hydroxide and KOH/OH methods of hydrolysis with respect to phospholipid hydrolysis

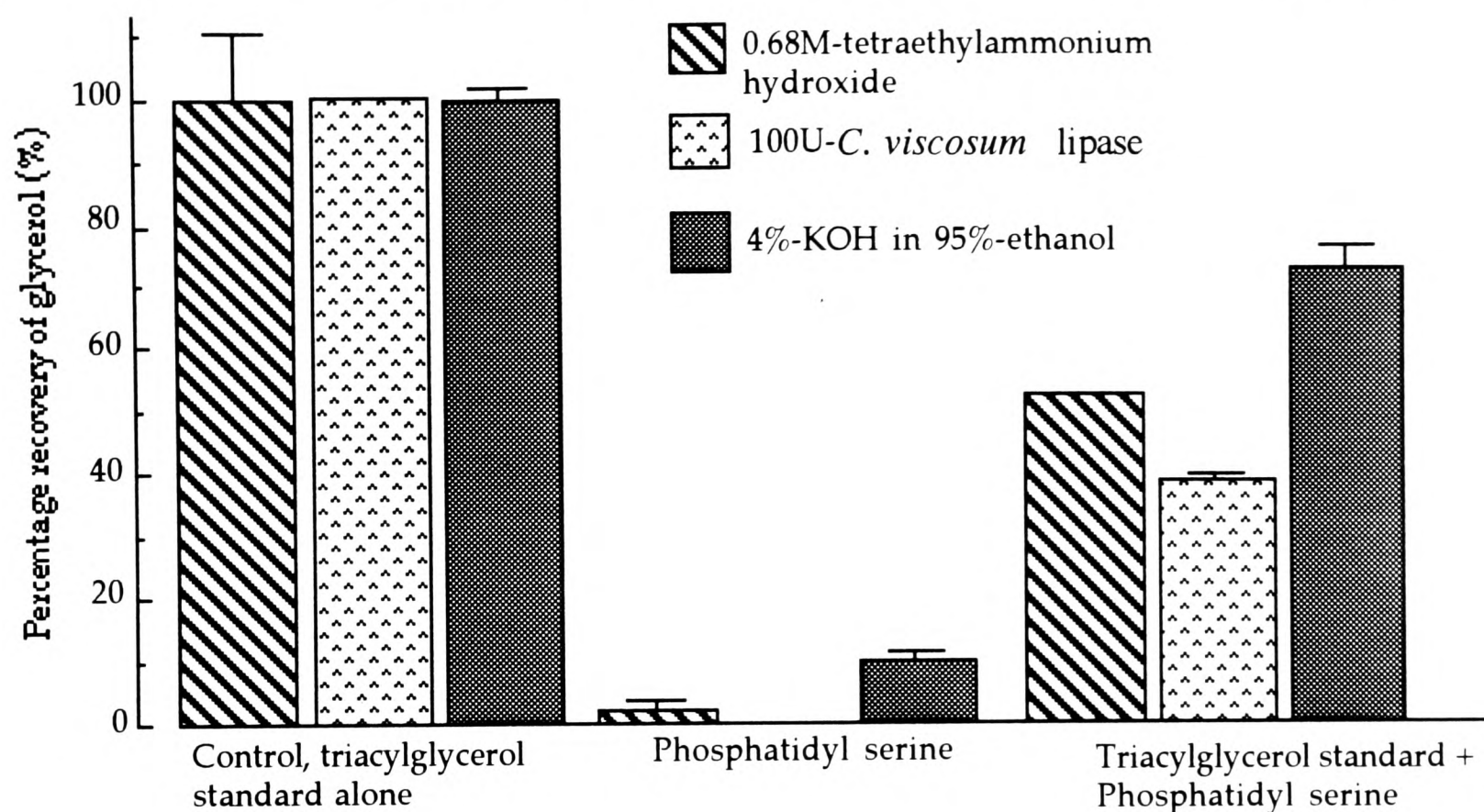

30 μ l or 30nmol-phosphatidyl serine of dried down stock solution, or 27nmol-triacylglycerol standard or a mixture of phospholipid and triacylglycerol standard were added to three sets of test tubes.

First set, : added 1.4ml, 0.1M-triethanolamine (pH 7.6, containing 6mM-MgSO₄/ 2mM-KCl/ 7mM-phosphoenolpyruvate/ 2mM-ATP) and 100U-*C. viscosum* lipase, mixed with small glass rod, incubated 30°C, 20min.

Second set, : added 50 μ l of 0.68m-tetraethylammonium hydroxide in 50%-ethanol, mixed (vortex for 30s) and heated to 60°C for 60min. 167 μ l of 0.2M-HCl was then added and the solution mixed and cooled to 4°C. 1.5ml of n-hexane was added, shaken and the hexane layer aspirated and discarded.

Third set, : added 0.5ml of 4%-KOH in 95%-ethanol, mixed, heated 60°C, 30min. Added 0.5ml cold 10%-PCA, mixed, cooled to 4°C and centrifuged (Mistral 6l; 500g, 10min, 4°C). Supernatant aspirated into a fresh tube and 0.25ml of sat. KHCO₃ was added, mixed and centrifuged as before.

The concentration of glycerolipid was calculated from the concentration of glycerol assayed (see section 11). Samples of each hydrolysis were added to cuvettes containing 0.1M-triethanolamine (pH 7.6) (containing 6mM-MgSO₄/ 2mM-KCl/ 7mM-phosphoenolpyruvate/ 2mM-ATP) together with 15 μ l of 20mM-NADH (final concentration 0.21mM), 5 μ l-pyruvate kinase (final concentration 5U/ml), 2 μ l-LDH (final concentration 5U/ml), and mixed with a small glass rod. The absorbance was measured using a spectrophotometer set at 340nm and the temperature maintained at 30°C (waterbath). The concentration of glycerol was calculated from the absorbance difference before and after the addition of 2 μ l glycerokinase (final concentration in assay 5U/ml) given the millimolar extinction coefficient for NADH of 6.22cm⁻¹. Data expressed as means \pm SEMs of the percentage recovery of glycerol assuming all glycerolipid was hydrolysed.

effective. Others that were ineffective (judged by inspection from the apparent degree of homogenisation, and the muscle formed a sheet) were 1ml minihomogeniser Dounce homogeniser, two ground glass pestles with different fits with 7ml smooth glass mortar that was tapered at the end and pestles with glass protrusions. The term homogenisation is used to describe the appearance of the muscle tissue within extraction medium following the use of the polytron which was the closest to a true homogenate although the bulk of the muscle tissue floated on top even after centrifugation (500g 10min). Homogenisation was usually twice and recoveries of added radioactive triacylglycerol tracer used in each experiment were >95% as discussed later.

Homogenisation of fresh or dried muscle strips in tetraethylammonium hydroxide and KOH/OH hydrolysis media. During organic extraction of triacylglycerol an excess of water can interfere and triacylglycerol extraction might not be complete. It was thought that the concentration of triacylglycerol could be measured in either fresh or dried soleus muscles by directly homogenising muscle tissue in hydrolysis medium. (Dry muscle was used because triacylglycerol concentrations are frequently quoted in units per dry muscle weight.) The glycerol concentration was measured after homogenisation and hydrolysis by both chemical methods. Soleus muscles were dried using a lyophilizer and over phosphorus pentoxide. Water loss was on average 74%. The results are given in Figure 2.7. There was no significant difference between triacylglycerol concentrations with fresh muscle, but significant differences were found between fresh and dried concentrations with each method of hydrolysis. This shows that muscle triacylglycerol may not be fully extracted when homogenised in hydrolysis medium and was therefore not adopted as a method of triacylglycerol extraction and hydrolysis.

Extraction of skeletal muscle triacylglycerol. As it was not possible to hydrolyse muscle triacylglycerol in homogenised and clarified solutions because of the presence of agents that interfere with hydrolysis or the glycerol assay, triacylglycerol must be extracted from muscle before hydrolysis. Two methods were investigated. Folch (1957) and Bligh and Dyer (1959) have described methods of extraction based on organic solvent extraction with 20vol (Folch) and 1vol (Bligh and Dyer) of chloroform-methanol (2:1, v/v (Folch) and (Bligh and Dyer)). In the

Figure 2.7 Effect of homogenising directly into tetraethylammonium hydroxide in ethanol or KOH in ethanol hydrolysis media on measurements of muscle triacylglycerol concentration

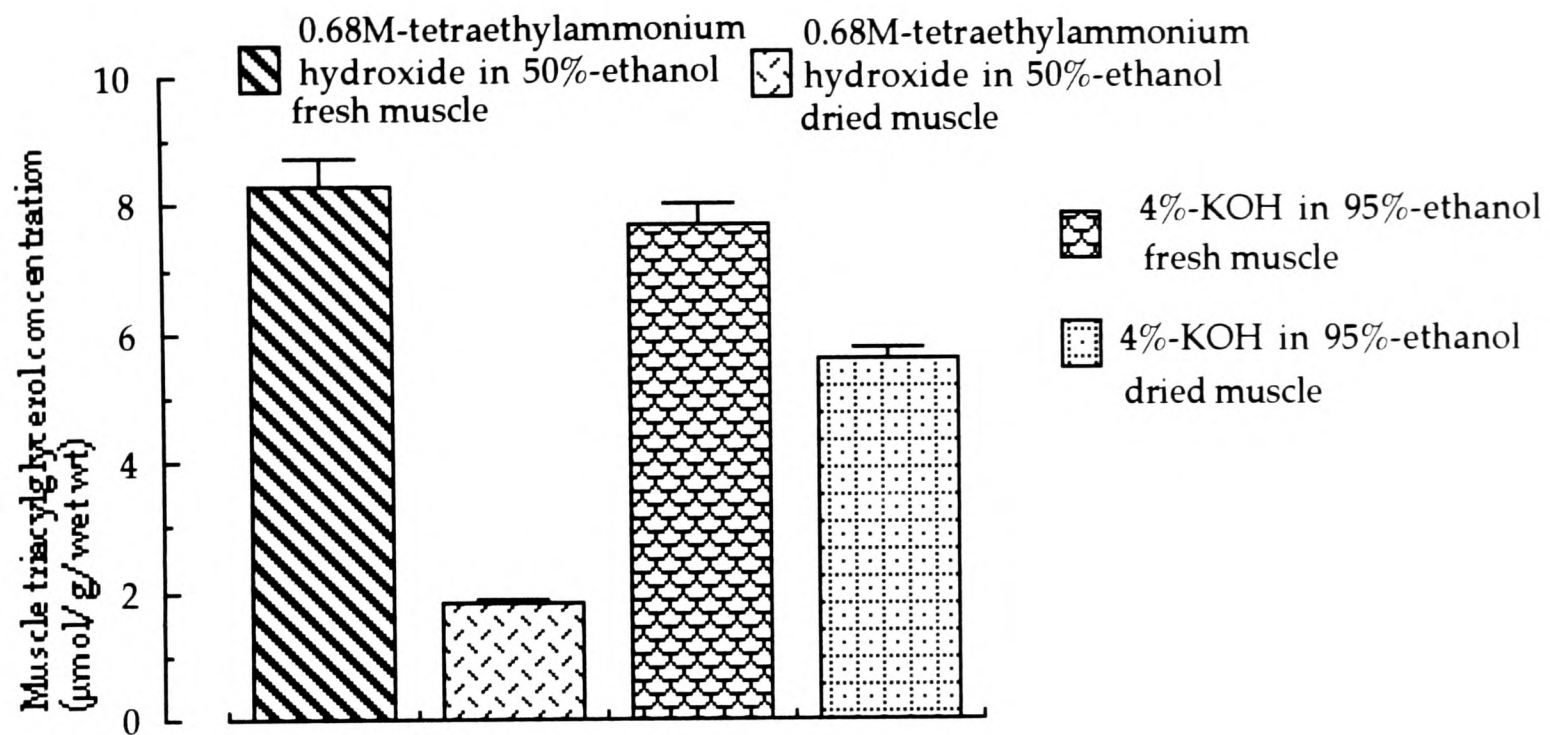

Muscle tissue was divided into four. Two portions were weighed and dried using a lyophiliser and over phosphorus pentoxide overnight and then reweighed.

For tetraethylammonium hydroxide a sample of fresh and dried muscle were hydrolysed by adding 50µl of 0.68M-tetraethylammonium hydroxide in 50%-ethanol, mixed (vortex for 30s) and the samples heated to 60°C for 60min. 167µl of 0.2M-HCl was then added to each and the solutions mixed and cooled to 4°C. 1.5ml of n-hexane was added, shaken and the hexane layer aspirated and discarded.

For the KOH/OH hydrolyses fresh to dried muscle tissue was added 0.5ml of 4%-KOH in 95%-ethanol, mixed and heated to 60°C for 30min. After this time 0.5ml of cold 10%-PCA was added, mixed, cooled to 4°C and centrifuged (Mistral 6l; 500g, 10min, 4°C). The supernatant was aspirated into a fresh tube and 0.25ml of sat. KHCO₃ was added, mixed and centrifuged as before.

The concentration of triacylglycerol was calculated from the concentration of glycerol assayed (see section 11). Samples of each hydrolysis were added to cuvettes containing 0.1M-triethanolamine (pH 7.6) (containing 6mM-MgSO₄/ 2mM-KCl/ 7mM-phosphoenolpyruvate/ 2mM-ATP) together with 15µl of 20mM-NADH (final concentration 0.21mM), 5µl-pyruvate kinase (final concentration 5U/ml), 2µl-LDH (final concentration 5U/ml), and mixed with a small glass rod. The absorbance was measured using a spectrophotometer set at 340nm and the temperature maintained at 30°C (waterbath). The concentration of glycerol was calculated from the absorbance difference before and after the addition of 2µl glycerokinase (final concentration in assay 5U/ml) given the millimolar extinction coefficient for NADH of 6.22cm⁻¹. Data expressed as means ± SEMs of triacylglycerol concentration from the glycerol assay glycerol given the muscle weight either at the time of homogenisation for fresh muscle or before drying for the dried muscle. n= 3 hydrolyses and 3 glycerol assays per hydrolysis.

Folch extraction procedure this is followed by an aqueous salt with 4mM-MgCl₂, mixed, and held on ice for 30min to form a two phase system of extraction. With the Bligh and Dyer method a second vol of chloroform is added and homogenised followed by a vol of H₂O and homogenised again. The Folch method requires extraction for 16h and the Bligh and Dyer method just allows sufficient time for the phases to separate followed by filtering. The Folch method includes a centrifugation step, the upper aqueous layer is aspirated and discarded, and the lower organic layer containing extracted triacylglycerol is evaporated to dryness (60°C using a waterbath). With the Bligh and Dyer method the residue is re-extracted with a further volume of chloroform, filtered again and the filter rinsed with 0.5vol-chloroform. The sample has 1:2 (v/v)-chloroform-methanol added, homogenised and the upper layer is aspirated and discarded, the lower layer being dried down by evaporating the solvents (60°C waterbath).

Dried down samples were resuspended with absolute ethanol, a sample subjected to a *C. viscosum* lipase hydrolysis (see section 7.2), and samples from this incubation taken for assay of glycerol. The results were 3.3±1.5µmol/g wet wt (n=10 assays from 2 extractions) with the Folch method and 1.5±0.3µmol/g wet wt (n=10) with the Bligh and Dyer method. The Folch method was used in further experiments.

Comparison of chemical and enzymatic hydrolyses of muscle triacylglycerol.

A direct comparison was made with all three methods of hydrolysis studied of the KOH/OH, with the tetraethylammonium hydroxide and the *C. viscosum* lipase methods of triacylglycerol hydrolysis. A sample (~1g) of muscle tissue was extracted, aliquoted and aliquots hydrolysed by each method. Given the specificity of the lipase and tetraethylammonium hydroxide methods the silicic acid step was omitted for samples that were to be hydrolysed by these methods. The glycerol released from hydrolysed triacylglycerol was measured and radioactive tracer (glycerol tri [¹⁴C] palmitate) was added to monitor losses during processing and final triacylglycerol concentrations were adjusted accordingly. (See section 8 Radioactive recoveries.)

The results are plotted in Figure 2.8. Both chemical methods of hydrolysis gave exactly the same mean triacylglycerol concentration and lipase measurement was smaller. The variation

Figure 2.8 Comparison of tetraethylammonium hydroxide, KOH/OH and lipase from *C. viscosum* methods of hydrolysis of extracted muscle triacylglycerol

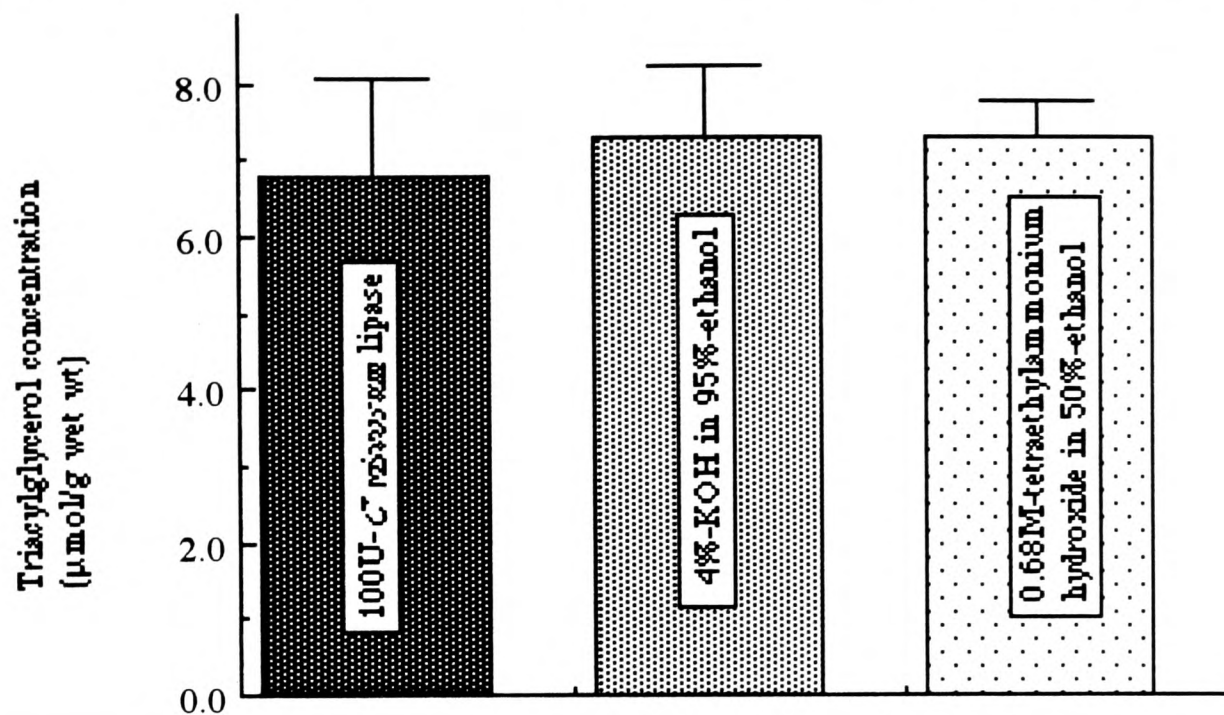

All experiments were repeated, *i.e.* twice. In one all three methods of hydrolysis compared; in the other two chemical methods were compared. In both experiments glycerol tri[^{14}C] palmitate was used to monitor losses.

The first experiment 1.046g of soleus muscle was chopped with fine scissors and homogenised (polytron; large aggregate, position 5, 1min) in 20.92ml or 20vol chloroform/methanol (2:1, v/v) containing glycerol tri[^{14}C] palmitate, at 4°C. After extracting overnight sample centrifuged (Mistral; 500g, 15min, 4°C). Muscle re-extracted again (non-radioactive chloroform/methanol), centrifuged and the two solutions combined. 6.9ml of 4mM-MgCl₂ added, shaken, kept at 4°C for 30min, centrifuge as before. Upper, aqueous layer aspirated and discarded. Lower organic layer containing triacylglycerol divided into three equal parts and each dried down at 65°C (waterbath). The second experiment was conducted in exactly the same manner.

For *C. viscosum* lipase hydrolysis one portion resuspended with 400µl-absolute ethanol and heated gently to disperse the deposit. Cooled to 30°C samples (30µl) added to cuvettes with 1.4ml 0.1M-triethanolamine (pH 7.6)/ 6mM-MgSO₄ / 2mM-KCl / 7mM-phosphoenolpyruvate/ 2mM-ATP) and 100U-*C. viscosum* lipase. Mixed and incubated at 30°C for 20min. Added remaining glycerol assay reagents (15µl of 20mM-NADH (final conc. 0.21mM), 5µl-pyruvate kinase (final conc. 5U/ml, and 2µl-LDH (final conc. 5U/ml) and glycerol conc. measured (see section 11 glycerol assay).

For KOH hydrolysis second pellet was resuspended with 6ml-chloroform and 0.5g-silicic acid, mixed, left on ice 1h, centrifuged (Mistral swing out rotor; 500g, 10min, 4°C), supernatant divided into two equal parts and each dried down (heating, gaseous N₂). To these portions was added 0.5ml 4%-KOH in 95%-ethanol, mixed, heated to 60°C, 30min. Samples cooled to 4°C, 0.5ml of 10%-PCA added, centrifuged, supernatant aspirated to which was added 0.25ml sat.-KHCO₃. Samples centrifuged again as above and aliquots of the supernatant assayed for glycerol (see section 11).

For tetraethylammonium hydroxide hydrolysis samples were resuspended with 0.1ml of 0.68M-tetraethylammonium hydroxide in 50%-ethanol and heated to 60°C for 60min. 0.1ml of 0.1N-HCl added to each, the samples mixed. 1.5ml hexane added, samples shaken and upper hexane wash discarded. Samples assayed for glycerol (see section 11).

For all samples above aliquots were taken at points in the processing of muscle tissue and the radioactivity counted. From the radioactive counts recoveries were assessed and muscle triacylglycerol concentrations measured by the glycerol liberated were adjusted accordingly. Data are expressed as means±SEMs for muscle triacylglycerol concentrations for 3 hydrolyses in each experiment.

in triacylglycerol concentration about the mean shows that with lipase the sem as a percentage of the mean is 19%, for KOH/OH it is 13% and the smallest variation recorded was with tetraethylammonium hydroxide which was 6%.

Effect of various solvents to resuspend extracted muscle triacylglycerol before enzymatic hydrolysis. Lipase from *C. viscosum* has been demonstrated to be very specific for triacylglycerol and is practically a very simple method. It was thought that the possible reason for incomplete hydrolysis of muscle triacylglycerol with lipase, may have been the result of incomplete resuspension of the triacylglycerol pellet or the formation of incorrectly sized emulsion particles and attempts were made to improve glycerol recovery. A number of solvents were used to resuspend samples of extracted muscle triacylglycerol containing glycerol tri [^{14}C] palmitate. Criteria for success were that the solvent had to be compatible with acrylic cuvettes used in hydrolyses with lipase and would not interfere with the glycerol assay, that recovery of radioactivity was complete, and that the concentration of triacylglycerol matched those from chemical methods of hydrolysis of the same muscle extract. The variation between duplicate experiments was large. The difference in radioactive recovery was 74% versus 15% and triacylglycerol concentration $7.3\mu\text{mol/g}$ versus $11\mu\text{mol/g}$. Therefore the method of hydrolysis of muscle triacylglycerol using lipase from *C. viscosum* was not adopted.

Recovery of radioactive tracer. In some experiments muscle triacylglycerol concentrations were lower than expected for fed soleus muscle. By adding a radioactive tracer it was possible to monitor losses that may have been incurred during processing of muscle tissue before glycerol assay. Experiments were conducted where muscle tissue was extracted using chloroform/methanol (2:1, v/v) containing glycerol tri [^{14}C] palmitate. Samples were taken at each stage in the process and radioactivity counted. These stages were the homogenate solution, the combined homogenate solutions after re-extraction of the muscle tissue with non-radioactive chloroform/methanol, the upper and lower phases of the salt wash of the homogenate solutions, and resuspending samples with chloroform before and after the silicic acid treatment. The results are expressed as the recovery of radioactivity in the sample as a percentage of the specific activity of the chloroform/methanol stock solution and are given in Figure 2.9. Losses of radioactivity

Figure 2.9 Recovery of radioactivity from glycerol tri [^{14}C] palmitate tracer during stages of muscle extraction

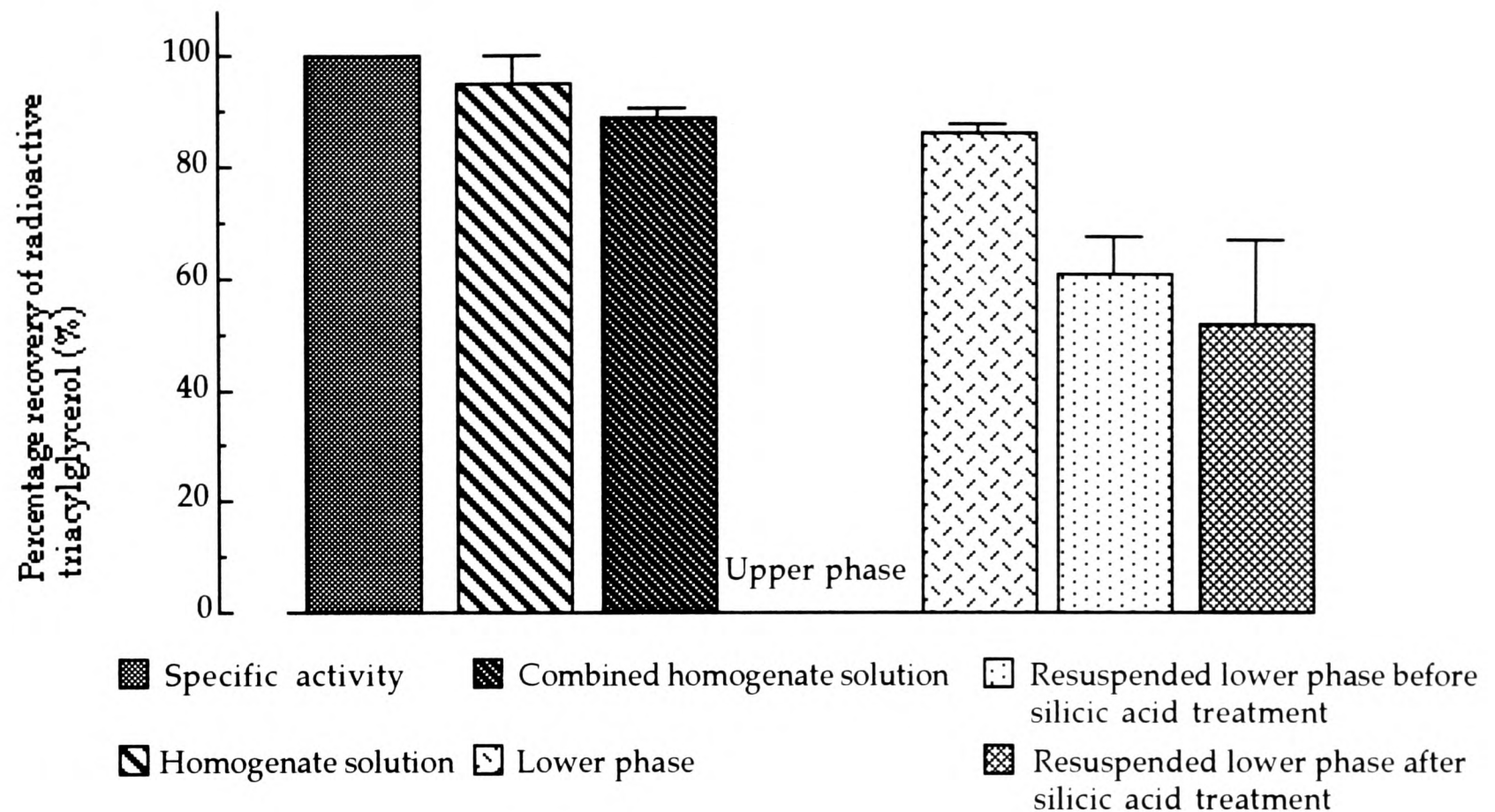

Muscle tissue was chopped with fine scissors and homogenised (polytron; large aggregate, position 5 for 1min) using 20vol of chloroform/methanol (2:1, v/v) containing glycerol tri [^{14}C] palmitate at 4°C. After allowing the sample to extract overnight the sample was centrifuged (Mistral; 500g, 15min, 4°C). Muscle tissue was extracted again by homogenising in non-radioactive chloroform/methanol, centrifuged and the two solutions without muscle tissue were combined. 0.3vol of 4mM-MgCl₂ was added, shaken, kept at 4°C for 30min before centrifuging as before. The upper, aqueous layer was aspirated into a fresh tube. The lower organic layer containing triacylglycerol was dried down by evaporation at 65°C (waterbath). The extracted triacylglycerol was resuspended with 6ml-chloroform and 0.5g-silicic acid (oven dried) added and mixed. Samples were taken at the stages of the extraction process given in the figure and their radioactive content counted. Data are expressed as the radioactive counts from samples as a percentage of the specific activity of the chloroform/methanol extraction medium and are means \pm SEMs for 5 experiments.

were significant. The decrease in activity between the homogenate solution and the combined homogenate solutions involved a dilution which is not represented on the graph. Allowing for this does not alter the significant difference in the loss of radioactivity during the extraction procedure. Upper layer counts were no different than background counts. The decrease at the resuspension stage was only this low in two of the experiments presented here. In other experiments where recoveries were measured resuspension of extracted muscle triacylglycerol with chloroform resulted in >90% recovery of added radioactive counts. Losses of counts were also found with the silicic acid step in these experiments (not shown). However, the important recovery is the radioactivity found from the lower phase as a percentage of that found in the combined homogenate solutions and these are 97%. Recoveries of radioactivity were measured in 6 samples following hydrolysis and hexane extraction of fatty acids and >90% recovery was found.

Recalculation of the triacylglycerol concentrations in these experiments to include such recoveries results in triacylglycerol concentrations in accord with published data ($7\mu\text{mol/g}$ wet wt here and for fresh soleus muscle in Wakata *et al.*, 1990). The KOH/OH method of hydrolysis was rejected in favour of the tetraethylammonium hydroxide method of muscle triacylglycerol on the basis that the silicic acid step was not necessary using the tetraethylammonium hydroxide method but is an essential step in the method for accurate measurement of triacylglycerol concentration with the KOH/OH method, and because this step incurred unacceptable losses. In subsequent experiments radioactive tracers were included and samples of the combined homogenate solutions were analysed for their radioactive content.

In a separate experiment the radioactive recovery of counts from the tetraethylammonium hydroxide hydrolysis of extracted muscle triacylglycerol, combined with the hexane washes gave 90% of the counts expected from complete resuspension of the extracted muscle triacylglycerol.

15 Control experiments

Triacylglycerol concentration from fed with 48h starved soleus muscle in vivo. Figure 2.10 shows that the triacylglycerol concentration in freshly excised soleus and heart muscles

Figure 2.10 Comparison of triacylglycerol concentration from fed with 48h starved soleus muscle *in vivo*

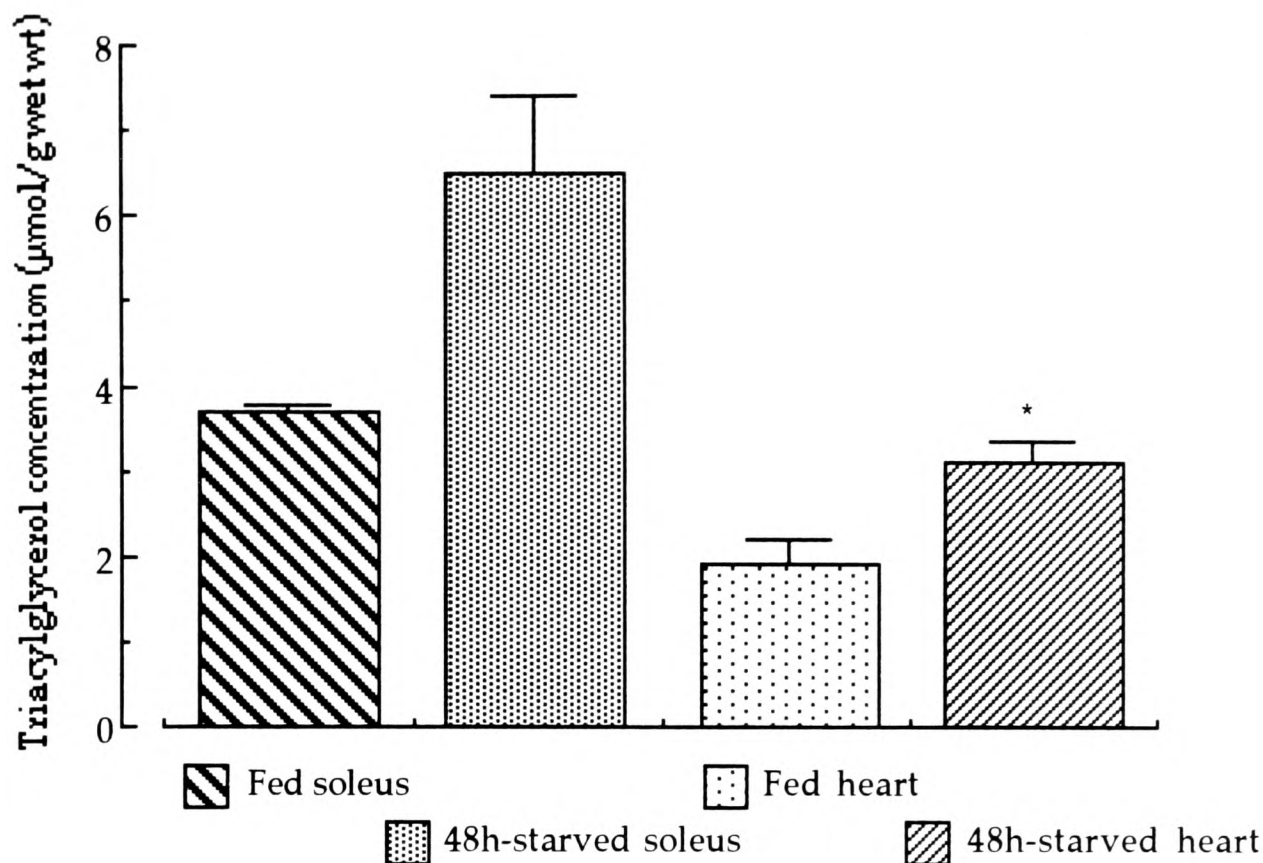

The heart and soleus muscles from 48h starved and fed rats were freshly excised. Hearts were fixed to a metal catheter and were perfused with warm (30°C) oxygenated KHB previously gassed with 95% O₂: 5% CO₂ until the perfusate ran colourless. Hearts were bisected, blotted dry and placed in liquid nitrogen until processed further. Soleus muscles were wrapped in foil and plunged into liquid nitrogen until processed further. Hearts were then thawed, freeze clamped using a pair of freeze clamping tongs previously cooled to liquid nitrogen temperature and crushed in liquid nitrogen in a pestle and mortar. Muscle tissue was chopped with fine scissors and homogenised (polytron; large aggregate, position 5 for 1min) using 20vol of chloroform methanol (2:1, v v) at 4°C. After allowing the sample to extract overnight the sample was centrifuged (Mistral; 500g, 15min, 4°C). 0.3vol of 4mM-MgCl₂ was added, shaken, kept at 4°C for 30min before centrifuging as before. The upper, aqueous layer was aspirated and discarded. The lower organic layer containing triacylglycerol was dried down by evaporation at 65°C (waterbath). The extracted triacylglycerol was resuspended with absolute ethanol and samples transferred to cuvettes containing 1.4ml of 0.1M-triethanolamine (pH 7.6) (containing 6mM-MgSO₄ 2mM-KCl 7mM-phosphoenolpyruvate/ 2mM-ATP) and 100U-*C. viscosum* lipase. The cuvette contents were mixed and incubated at 30°C for 20min. After this time the remaining glycerol assay reagents (15µl of 20mM-NADH (final concentration 0.21mM), 5µl-pyruvate kinase (final concentration of 5U/ml, and 2µl-LDH (final concentration 5U/ml) were added and the glycerol concentration was measured (see section 11 glycerol assay). Data are expressed as means ± SEM for 4 soleus muscle extracts and 2 heart extracts with 3 glycerol assays per hydrolysis.

from 48h starved rats was double that from fed. Triacylglycerol concentrations were lower than expected probably because of losses in processing as extractions were not monitored with radioactive tracer. The overall pattern of increase was similar to previous studies (Denton and Randle, 1967).

Incorporation of 0.6mM [³H]-palmitic acid into muscle triacylglycerol during short term incubation of soleus and diaphragm. In a pilot experiment soleus and diaphragm muscles were incubated with tritiated palmitic acid for 1h and the concentration of tritiated lipid measured by thin layer chromatography and glycerol assay. Figure 2.11 shows that despite low triacylglycerol concentrations incorporation of [³H] palmitic acid was demonstrable after only 1h of incubation. Table 2.12 confirmed incorporation of [³H] palmitic acid into triacylglycerol using TLC. Although large losses were incurred using TLC, these results never the less show that [³H] palmitic acid was incorporated specifically into triacylglycerol.

16 Time course for incorporation of 0.6mM [³H]-palmitic acid into soleus muscle lipids *in vitro*

Figure 2.13 show that the incorporation of [³H]-palmitic acid into muscle triacylglycerol increases with the length of incubation (1, 7, 15 and 24h) of muscle strips with 0.6mM [³H] palmitic acid up to a maximum at 15h. Figure 2.14 confirms that the lipid species incorporating labelled fatty acid is triacylglycerol. In subsequent experiments the maximum length of incubation was 15h. In subsequent experiments the maximum length of incubation was 15 hours.

17 Incorporation of 0.6mM [³H]-palmitic acid into soleus muscle triacylglycerol *in vitro* during long term culture

Figure 2.15 shows the results of an initial experiment in which soleus muscle strips were incubated in culture medium containing 0.6mM-palmitic acid. TAG concentrations did not differ significantly from those of strips incubated in medium alone (Medium 199) or without substrates (Krebs-Henseleit buffer) or unincubated (*i.e.* freshly excised soleus muscle strips frozen in

Figure 2.11 Incorporation of 0.6mM [³H]-palmitic acid into muscle triacylglycerol during short term incubation of soleus and diaphragm

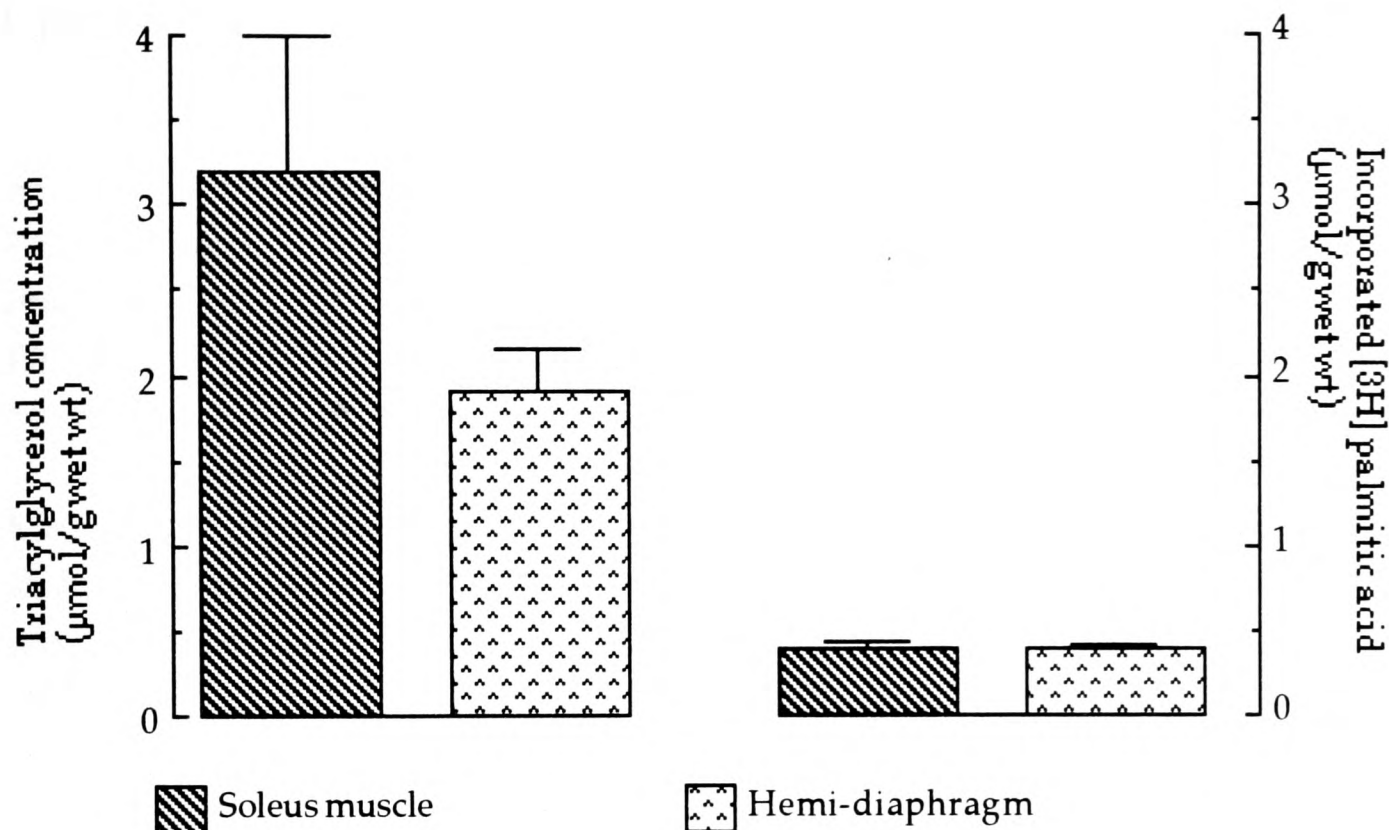

From three fed rats 6 soleus and 6 hemi-diaphragms were dissected and incubated in Medium 199 containing 0.6mM [³H] palmitic acid bound to 0.85%-BSA at 37°C for 1h with shaking. After incubation muscles were washed in medium 199 without palmitic acid-BSA to remove unincorporated fatty acid. Muscle were extracted (see section 7.1) with chloroform/methanol containing radioactive triacylglycerol by homogenisation (polytron), centrifugation (Mistral 6L; 500g, 10min, 4°C), and the muscle was allowed to extract overnight at 4°C. The extract was centrifuged as before and the muscle tissue re-extracted by homogenisation as before and was centrifuged as before. Muscle tissue was removed and the two solutions combined. 0.3vol of 4mM-MgCl₂ was added, shaken and left on ice for 30min. Separation of the two phases was completed by centrifugation as before. The upper aqueous layer was aspirated and discarded and the lower organic layer blown down to dryness with nitrogen gas.

Samples of extracted muscle lipid were resuspended with ethanol and aliquots added to cuvettes containing 1.4ml of 0.1M-triethanolamine (pH 7.6) (containing 6mM-MgSO₄/ 2mM-KCl/ 7mM-phosphoenolpyruvate/ 2mM-ATP) and 100U-*C. viscosum* lipase. The cuvette contents were mixed and incubated at 30°C for 20min. After this time the remaining glycerol assay reagents (15μl of 20mM-NADH (final concentration 0.21mM), 5μl-pyruvate kinase (final concentration of 5U/ml, and 2μl-LDH (final concentration 5U/ml) were added and the glycerol concentration was measured (see section 11 glycerol assay). n= 3 glycerol assays/muscle extract.

Table 2.12 Incorporation of ^3H palmitic acid into lipid species - analysis by thin layer chromatography

Lipid species	Concentration of lipid species in muscle	
	Soleus (nmol/g wet wt)	Diaphragm (nmol/g wet wt)
Triacylglycerol	28±0.03(6)	23±0.003(6)
Free fatty acid	205±0.04(6)	201±0.02(6)
Phospholipid	170±0.03(6)	161±0.01(6)

From three fed rats 6 soleus and 6 hemi-diaphragms were dissected and incubated in Medium 199 containing 0.6mM [^3H] palmitic acid bound to 0.85%-BSA at 37°C for 1h with shaking. After incubation muscles were washed in medium 199 without palmitic acid-BSA to remove unincorporated fatty acid. Muscle were extracted (see section 7.1) with chloroform/methanol containing radioactive triacylglycerol by homogenisation (polytron), centrifugation (Mistral 6L; 500g, 10min, 4°C), and the muscle was allowed to extract overnight at 4°C. The extract was centrifuged as before and the muscle tissue re-extracted by homogenisation as before and was centrifuged as before. Muscle tissue was removed and the two solutions combined. 0.3vol of 4mM-MgCl₂ was added, shaken and left on ice for 30min. Separation of the two phases was completed by centrifugation as before. The upper aqueous layer was aspirated and discarded and the lower organic layer blown down to dryness with nitrogen gas.

Samples of extracted muscle lipid was resuspended with chloroform and samples were spotted at the origin on thin layer chromatography plates (see section 9). Lipid species present in the muscle extract were separated by thin layer chromatography and the first solvent mixture (isopropyl diether: glacial acetic acid (94:6)). When the solvent front had reached half way the second solvent mixture (40°C-60°C petroleum spirit: diethyl ether: glacial acetic acid (90:9:1)) was used. The solvent front travelled to 3/4 the way up the plate and the plate was removed and dried under nitrogen gas. The plate was sprayed with 0.2%-aqueous 8-anilino-naphthelene sulphonic acid and the spots visualised under UV light. Spots were scraped from plates and the lipid extracts by adding 0.5ml-chloroform and shaking at 4°C. Thin layer chromatography references were olive oil diluted with ethanol, palmitic acid in ethanol and stock phosphatidyl serine in chloroform methanol. Samples were centrifuged (eppendorf centrifuge: 500g, 15min, 4°C). Samples of supernatant were counted using the dual counting program of the radioactivity counter (see section 10). Values are mean ± SEMs for the number of muscles is shown in parentheses.

Figure 2.13 Time course for incorporation of [^3H] palmitic acid into skeletal muscle triacylglycerol

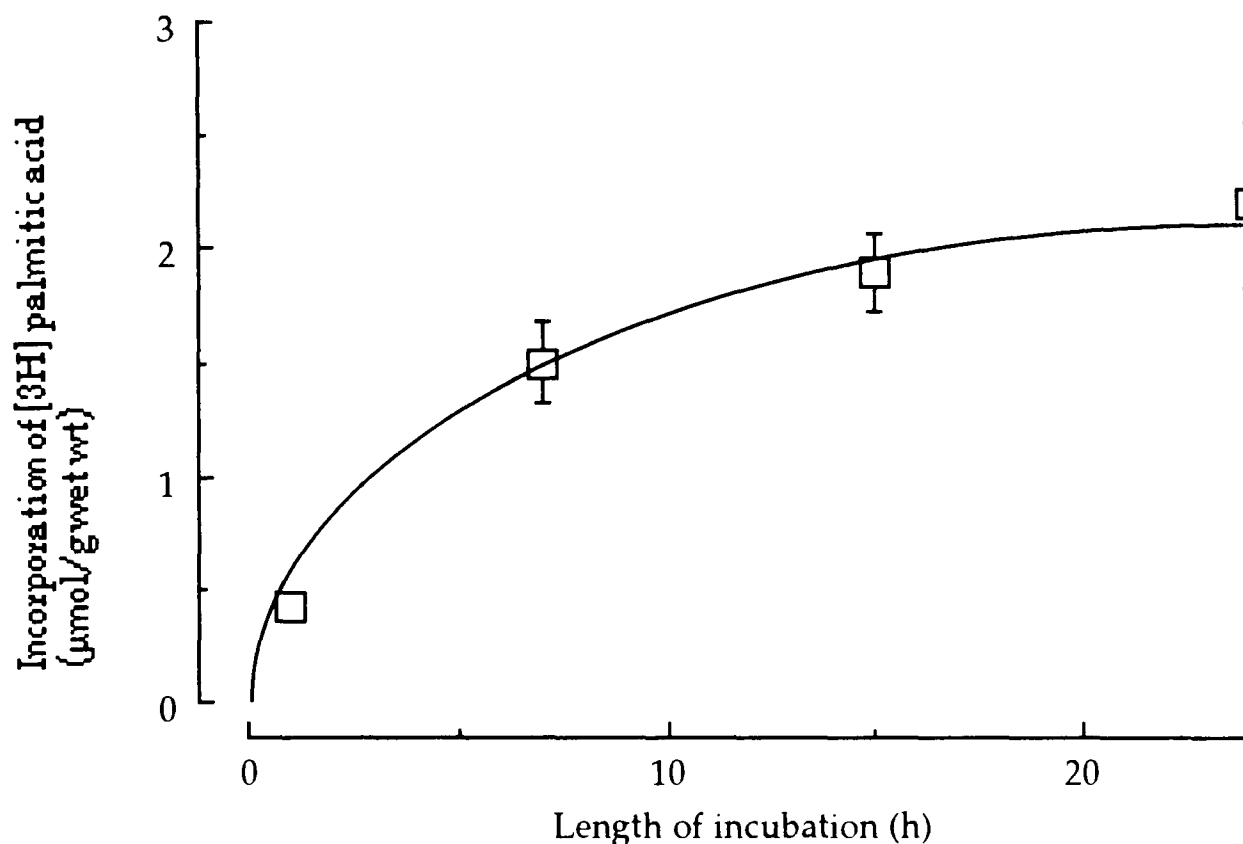

Muscle strips were prepared as in section 6 and incubated in pre-gassed ($\text{O}_2:\text{CO}_2$ (95%:5%)) Medium 199 containing 0.6mM [^3H] palmitic acid bound to 0.85% BSA. Incubations were maintained at 37°C , gassed as above periodically and flasks were shaken. Muscle strips were incubated for 1, 7, 15 and 24h. Following incubation muscle strips were washed with a little Medium 199 to remove incubation solutions and carefully blotted dry. Muscle strips were then homogenised (polytron) at 4°C in 20vol of chloroform/methanol (2:1, v/v) containing glycerol tri [^{14}C] palmitate and the triacylglycerol extracted overnight at 4°C . Homogenates were centrifuged (Mistral 6L; 500g, 10min, 4°C) and the muscle tissue removed from the top, re-extracted with chloroform/methanol without glycerol tri [^{14}C] palmitate. 0.3vol of 4mM- MgCl_2 was added, shaken and left on ice for 30min. Separation of the two phases was completed by centrifugation as before. The upper aqueous layer was aspirated and discarded, and samples of the lower organic layer dried down. Samples were resuspended with heptane and washed with 0.5ml of 50mM- NaHCO_3 made in 50%-ethanol, shaken and the aqueous layer was aspirated and discarded. This step to remove free fatty acids was repeated twice more. Samples of heptane were counted for ^3H and ^{14}C and then heptane removed under nitrogen gas. The concentration of incorporated palmitic acid into lipid was calculated from the specific activity of the culture medium. (^{14}C counts allowed adjustments to calculation allowing for losses.) Data represent the means \pm SEMs for 4 muscle strips per time point.

Figure 2.14 Time course for incorporation of [^3H] palmitic acid into skeletal muscle triacylglycerol - analysis by thin layer chromatography

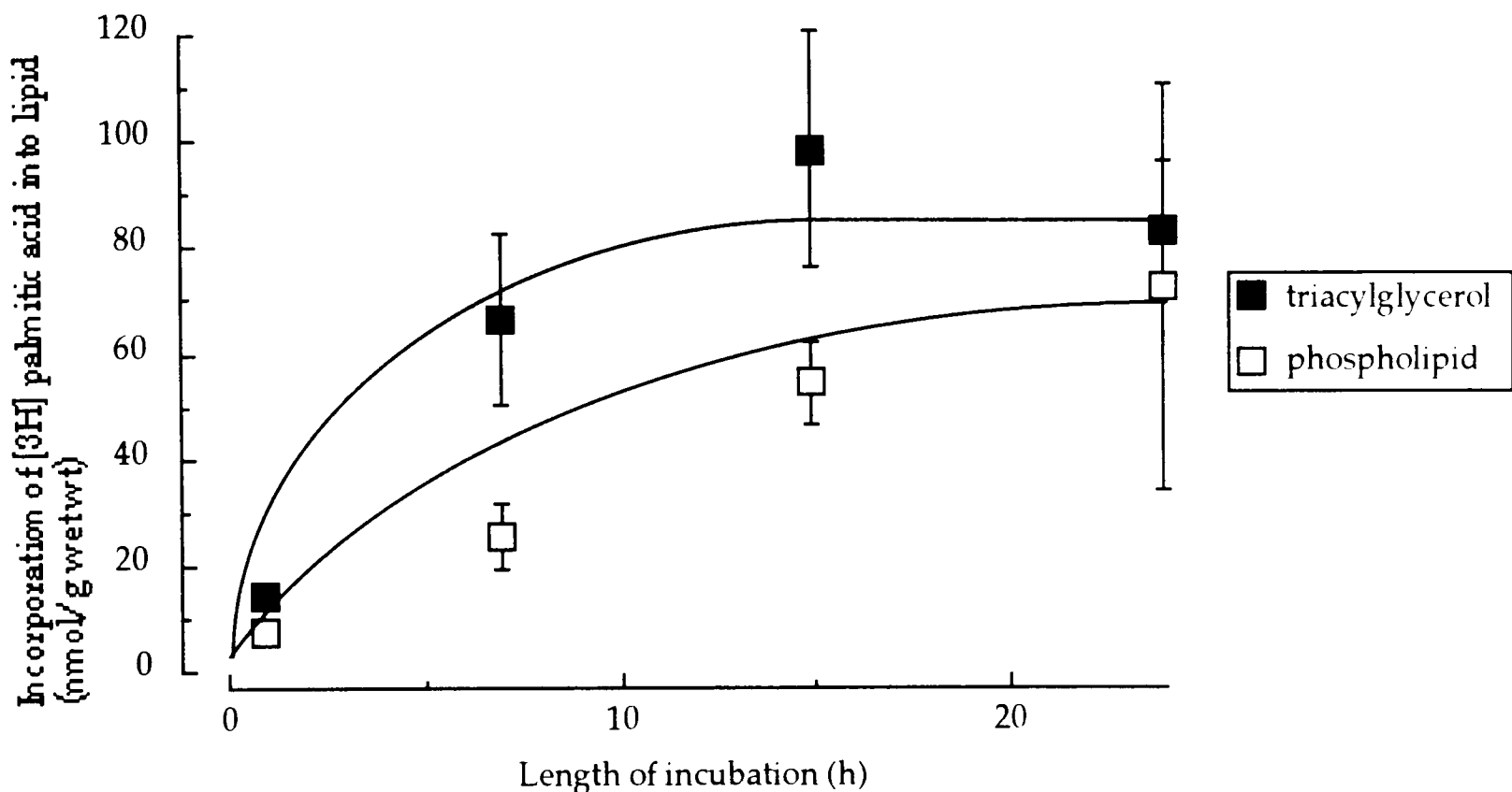

Muscle strips were prepared as in section 9 and incubated for 1, 7, 15 and 24h with shaking and periodic renewal of gas phase (O_2/CO_2) at 37° in medium 199 containing 0.6mM [^3H] palmitic acid bound to 0.85% -BSA. Following incubation muscle strips were washed Medium 199 to remove incubation solutions, blotted dry, homogenised (polytron) at 4°C in 20vol of chloroform/methanol (2:1, v/v) containing glycerol tri [^{14}C] palmitate and the triacylglycerol extracted overnight at 4°C . Homogenates were centrifuged (Mistral 6L; 500g, 10min, 4°C), muscle tissue removed and, re-extracted with chloroform/ methanol, 0.3vol of 4mM - MgCl_2 was added, shaken and left on ice for 30min. Separation of phases was completed by centrifugation as before. The upper aqueous layer was discarded and samples of lower layer were dried by a stream of N_2 . Samples were resuspended in heptane, washed with 0.5ml of 50mM - NaHCO_3 in 50% -ethanol, shaken and the aqueous layer discarded. This step, to remove FFA, was repeated x2. Heptane was removed under nitrogen gas, samples resuspended with chloroform and spotted on TLC plates. Lipid species present in the muscle extract were separated by TLC and the first solvent mixture (isopropyl diether: glacial acetic acid (94:6)). When the solvent front had reached half way the second solvent mixture (40°C - 60°C petroleum spirit: diethyl ether: glacial acetic acid (90:9:1)) was used. The solvent front travelled to $3/4$ the way up the plate and the plate was removed and dried under nitrogen gas. The plate was sprayed with 0.2% -aqueous 8-anilino-naphthelene sulphonic acid and the spots visualised under UV light. Spots were scraped from plates and the lipid extracts by adding 0.5ml -chloroform and shaking at 4°C . Thin layer chromatography references were olive oil diluted with ethanol and stock phosphatidyl serine in chloroform-methanol. Samples were centrifuged (eppendorf centrifuge: 500g, 15min, 4°C). Samples of supernatant were counted using the dual counting program of the radioactivity counter (see section 10). Data are represented as means \pm SEMs for 4 muscle strips per time point.

Figure 2.15 Incorporation of 0.6mM [³H]-palmitic acid into soleus muscle triacylglycerol *in vitro* during long term culture

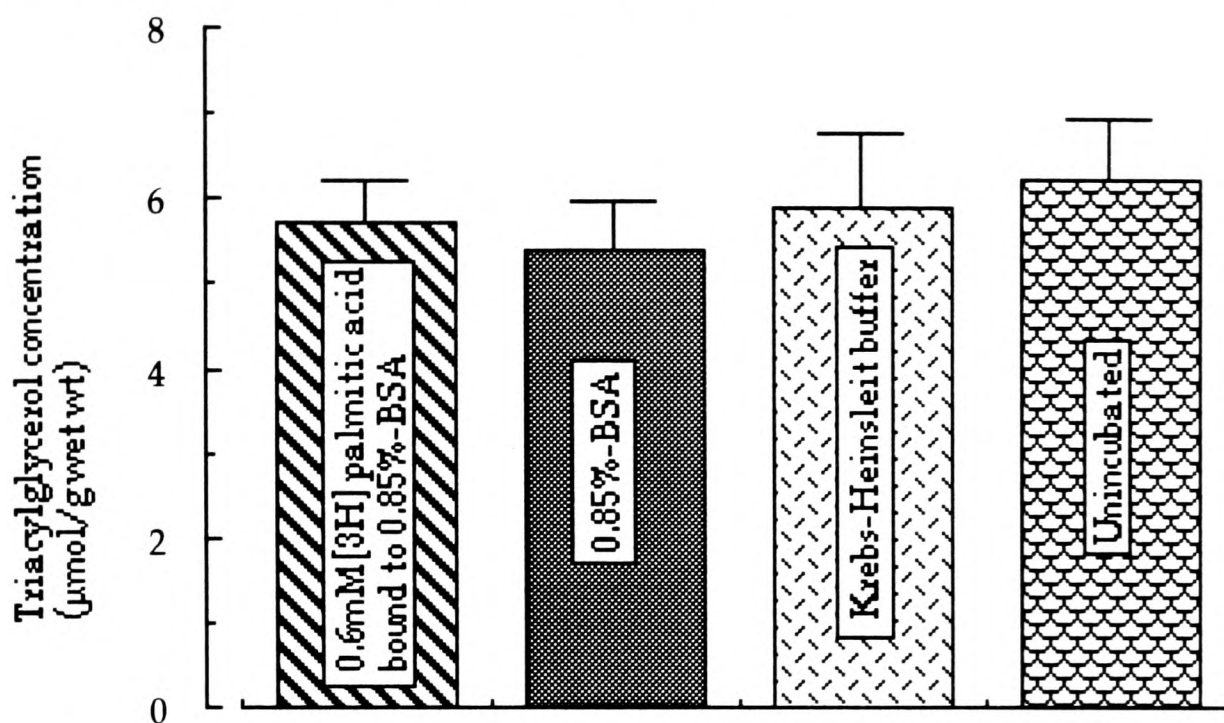

Soleus muscles were bisected into strips, attached to muscle clips under a little tension and by ligatures, and either incubated in sterile flasks in pre-gassed ($O_2:CO_2$ (95%:5%)) medium 199 containing 0.6mM [³H] palmitic acid bound to 0.85%-BSA, or 0.85%-BSA, or Krebs-Henseleit buffer or frozen in liquid N_2 in foil. Incubations, with shaking, were for 15h at 37°C and gassed periodically. Differences between rats were minimised by incubating the 4 strips from a rat, one strip in each culture medium and one not incubated. Following incubation strips were washed (Medium 199), blotted dry, chopped with small scissors, 0.5ml of chloroform-methanol mix (2:1 (v/v)) containing glycerol tri [¹⁴C] palmitate added, poured into a glass thick walled test tube, homogenised (Polytron homogeniser PT10-35 medium aggregate, position 5) for 1min, and poured into a second test tube. The scintillation vial insert was rinsed with 0.5ml chloroform/methanol mix and poured into the second test tube. Then 1ml of chloroform/methanol was added to the homogenisation test tube to rinse the polytron probe and this added to the second test tube. The homogenising test tube was rinsed with a further 1ml of chloroform/methanol and poured into the second test tube. This last step was repeated and the total volume of added extraction solution was 4ml. Soleus muscle lipid was extracted overnight at 4°C. Homogenates were centrifuged (Mistral 6L; 500g, 10min, 4°C) and the muscle tissue removed from the top, re-extracted with chloroform/methanol without glycerol tri [¹⁴C] palmitate. 4mM-MgCl₂ was added, shaken and left on ice for 30min. Separation of the two phases was completed by centrifugation as before. The upper aqueous layer was aspirated and discarded and the lower organic layer blown down to dryness with nitrogen gas.

50µl-0.68M-tetraethylammonium hydroxide was added to each sample and heated to 60°C for 60min. 167µl-0.1M-HCl was then added, the sample removed from heat and mixed. 60µl was assayed for glycerol (see glycerol assay section 11). Samples were also counted for radioactive content.

Triacylglycerol concentrations were calculated from the glycerol concentration and adjusted for the recovery of ¹⁴C radioactive counts. Incorporation of [³H] palmitic acid was calculated from the specific activity of the 0.6mM [³H] palmitic acid-0.85%-BSA solution and adjusted to allow for recovery of ¹⁴C radioactivity. Data represent combined means ± SEMs for 4 separate experiments and 4 muscle strips in each experiment.

liquid nitrogen). Palmitic acid was incorporated into muscle triacylglycerol. Recovery (>95%) of radiolabelled triacylglycerol added to the extraction of individual muscle strips. Variation about mean values were on average 12%.

18 Effects of incubation of soleus muscle strips *in vitro* with 8-phenyltheophylline or adenosine deaminase on muscle triacylglycerol concentration

Table 2.16 shows that there was no significant difference from unity of ratios of means \pm SEMs for triacylglycerol concentrations with incubation of muscle strips \pm 8-phenyltheophylline. (Data were expressed as a ratio because it was collated from two separate experiments and there was variation in control values.) Figure 2.17 shows that adenosine deaminase did have a statistically significant effect to decrease the triacylglycerol concentration in soleus muscle after long term culture compared with cultured or uncultured muscle without adenosine deaminase. Recoveries of added radioactive triacylglycerol included in the extraction medium were >95%.

19 Triacylglycerol concentration in six freshly excised soleus muscles

The results of the above experiments showed that the concentrations of triacylglycerol in muscle strips varied substantially and except where indicated statistical analyses were only approximate. In a concluding experiment the triacylglycerol concentrations of six freshly excised soleus muscles were measured. Figure 2.18 shows the variation in the individual muscle triacylglycerol concentrations. The average triacylglycerol concentration is 8.2 ± 1.7 (n=6 soleus muscles). The SEM is 21% of the mean triacylglycerol concentration. Recoveries of added radioactive triacylglycerol included in the extraction medium were >95%.

Table 2.16 Effects of incubation of soleus muscle strips *in vitro* with 8-phenyltheophylline on muscle triacylglycerol concentration

Muscle culture medium	Ratio of triacylglycerol concentration with culture /triacylglycerol concentration with unincubated muscle strips
2 μ M-8-phenyltheophylline	1.3 \pm 0.25(6)
10 μ M-8-phenyltheophylline	1.3 \pm 0.22(6)
DMSO control	1.0 \pm 0.20(6)

Soleus muscles were dissected and bisected into strips, attached to muscle clips under a little tension and by ligatures, and placed in sterile flasks containing culture medium. Muscle strips were incubated in pregassed ($O_2:CO_2$ (95%:5%)) Medium 199 containing 2 μ M or 10 μ M-8-phenyltheophylline (final concentration) or 100 μ l-DMSO, or Medium 199 containing 0.85%-BSA, or Krebs-Henseleit buffer or were not incubated at all but following dissection were wrapped in labelled foil and submerged in liquid nitrogen. Incubations were maintained at 37°C, gassed as above periodically and flasks were shaken for 15h. Differences between rats were minimised by incubating the 4 strips from a rat, one strip in each culture medium and one not incubated. (Details are given the materials and methods of this chapter.) Following incubation muscle strips were washed with a little Medium 199 to remove incubation solutions and carefully blotted dry. Each muscle strip was chopped with small scissors and 0.5ml of chloroform-methanol mix (2:1 (v/v)) containing glycerol tri [^{14}C] palmitate added and poured into a glass thick walled test tube. The muscle strip was then homogenised using a motor driven polytron (Polytron homogeniser PT10-35) with a medium aggregate set at position 5 for 1min and poured into a second test tube. The scintillation vial insert was rinsed with 0.5ml chloroform/methanol mix and poured into the second test tube. Then 1ml of chloroform/methanol was added to the homogenisation test tube to rinse the polytron probe and this added to the second test tube. The homogenising test tube was rinsed with a further 1ml of chloroform/methanol and poured into the second test tube. This last step was repeated and the total volume of added extraction solution was 4ml. Soleus muscle lipid was extracted overnight at 4°C. Homogenates were centrifuged (Mistral 6L; 500g, 10min, 4°C) and the muscle tissue removed from the top, re-extracted with chloroform/methanol without glycerol tri [^{14}C] palmitate. 4mM-MgCl₂ was added, shaken and left on ice for 30min. Separation of the two phases was completed by centrifugation as before. The upper aqueous layer was aspirated and discarded and the lower organic layer blown down to dryness with nitrogen gas. 50 μ l-0.68M-tetraethylammonium hydroxide was added to each sample and heated to 60°C for 60min. 167 μ l-0.1M-HCl was then added, the sample removed from heat and mixed. 60 μ l was assayed for glycerol (see glycerol assay section 11). Sample were also counted for radioactive content. Triacylglycerol concentrations were calculated from the glycerol concentration and adjusted for the recovery of ^{14}C radioactive counts. Incorporation of [3H] palmitic acid was calculated from the specific activity of the 0.6mM [3H] palmitic acid- 0.85%-BSA solution and adjusted to allow for recovery of ^{14}C radioactivity. Data represent means \pm SEMs for the number of muscle strips given in parentheses. Two experiments were conducted. Data are expressed as ratios of unincubated muscle triacylglycerol concentration because controls were substantially different in the two experiments.

Figure 2.17 Effects of incubation of soleus muscle strip *in vitro* with 0.5U/ml adenosine deaminase on muscle triacylglycerol concentration

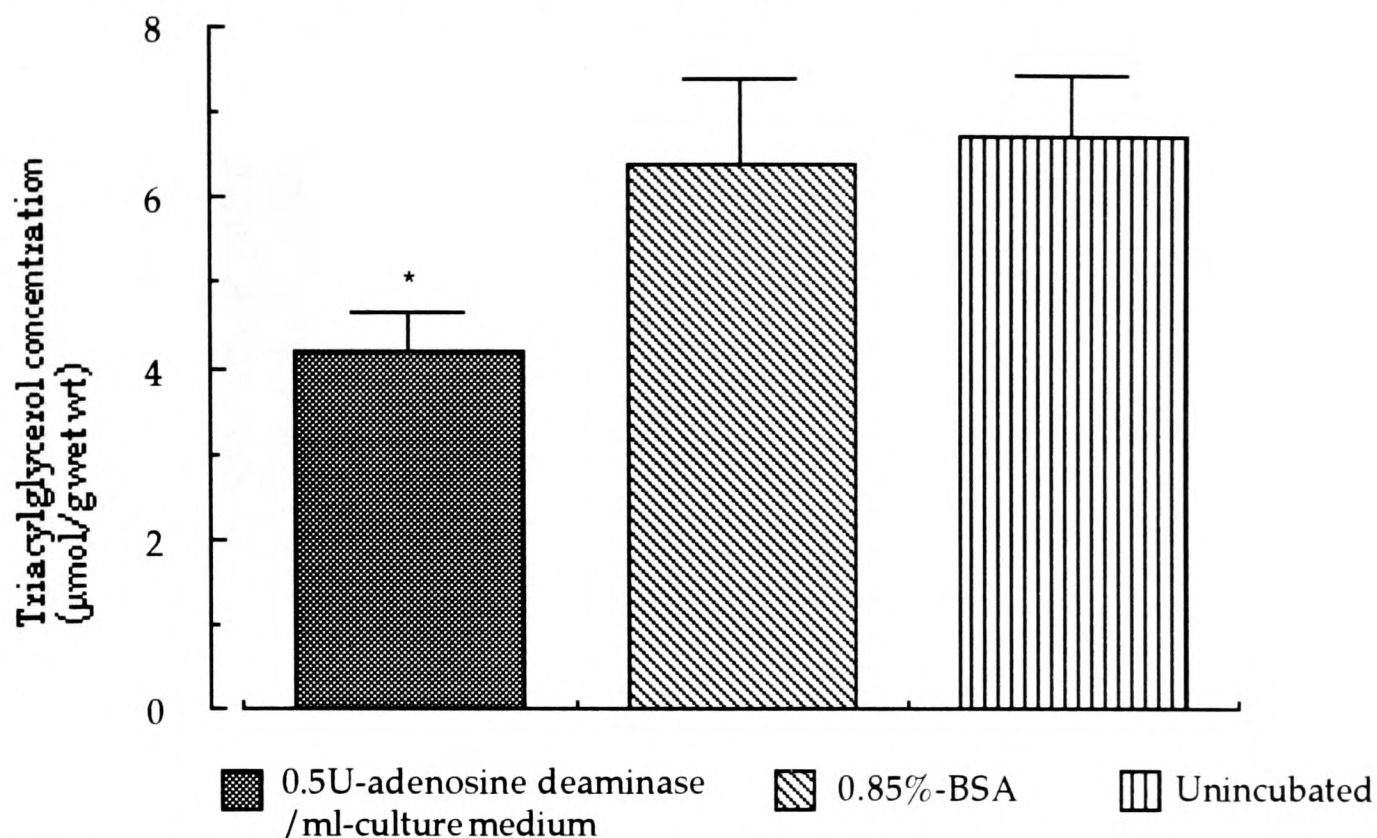

Soleus muscles were dissected bisected into strips, attached to muscle clips under a little tension and by ligatures, and incubated in sterile flask in pregassed ($O_2:CO_2$ (95%:5%)) Medium 199 containing 0.5 U/ml adenosine deaminase or 100 μ l-DMSO; or Medium 199 containing 0.85%-BSA; or Krebs-Henseleit buffer; or not incubated at all but frozen in liquid N_2 in foil. Incubations were for 15h at $37^\circ C$ with shaking, and gassed periodically and flasks. Differences between rats were minimised by incubating the 4 strips from a rat, one strip in each culture medium and one not incubated.

Following incubation muscle strips were washed (medium 199) blotted dry, chopped with small scissors and homogenised in a glass thick walled test tube (Polytron homogeniser PT10-35) at position 5 for 1min in 0.5ml chloroform-methanol (2:1 (v/v)) containing glycerol tri [^{14}C] palmitate added and poured into a second test tube. The scintillation vial insert was rinsed with 0.5ml chloroform/methanol mix and added to the second test tube together with 1ml of chloroform/methanol wash added of the polytron probe. The homogenising test tube was rinsed with a further 1ml of chloroform/methanol and poured into the second test tube. This last step was repeated and the total volume of added extraction solution was 4ml. Soleus muscle lipid was extracted overnight at $4^\circ C$. Homogenates were centrifuged (Mistral 6L; 500g, 10min, $4^\circ C$) and the muscle tissue removed from the top, re-extracted with chloroform/methanol without glycerol tri [^{14}C] palmitate. 4mM- $MgCl_2$ was added, shaken and left on ice for 30min. Separation of the two phases was completed by centrifugation as before. The upper aqueous layer was aspirated and discarded and the lower organic layer blown down to dryness with nitrogen gas.

50 μ l-0.68M-tetraethylammonium hydroxide was added to each sample and heated to $60^\circ C$ for 60min. 167 μ l-0.1M-HCl was then added, the sample removed from heat and mixed. 60 μ l was assayed for glycerol (see glycerol assay section 11.). Sample were also counted for radioactive content.

Triacylglycerol concentrations were calculated from the glycerol concentration and adjusted for the recovery of ^{14}C radioactive counts. Incorporation of [3H] palmitic acid was calculated from the specific activity of the 0.6mM [3H] palmitic acid- 0.85%-BSA solution and adjusted to allow for recovery of ^{14}C radioactivity. Data represent means \pm SEMs for the number of muscle strips (4 per experimental group) from two experiments collated. * denotes $P < 0.01$.

Figure 2.18 Triacylglycerol concentration in six freshly excised soleus muscles

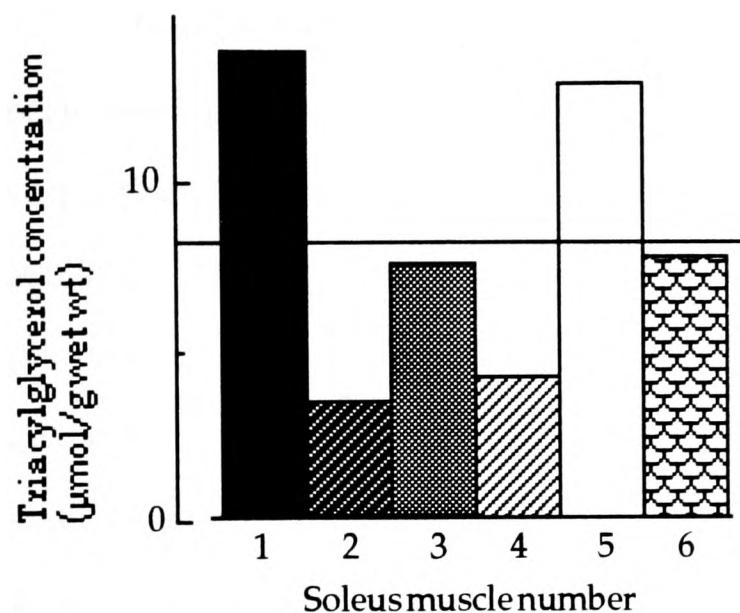

6 soleus muscles were freshly excised from anaesthetised rats, individually homogenised in chloroform/methanol (2:1, v/v) containing glycerol tri [^{14}C] palmitate, and allowed to extract overnight at 4°C . After extraction homogenates were centrifuged (Mistral 6L; 500g, 10min 4°C). Muscle tissue was rehomogenised in chloroform/methanol, the homogenate centrifuged as before, the 6 muscle tissue removed and the the two solutions combined. 4mM- MgCl_2 was added, shaken, left to stand on ice for 30min and centrifuged as before. The upper layer was aspirated and discarded and the lower layer dried down with nitrogen gas. Muscle extracts were resuspended and hydrolysed with 0.68M-tetraethylammonium hydroxide in 50%-ethanol, at 60°C for 60min. 0.2M-HCl was added, mixed, removed from heat and cooled to 4°C . n-Hexane was added, shaken, aspirated and discarded. The resulting solution was assayed for glycerol (see section 11). The concentration of triacylglycerol was calculated from the glycerol concentration and adjusted according to the recovery of radioactive counts. Data are expressed as individual triacylglycerol concentrations.

DISCUSSION

Development of protocol. Methods used to measure triacylglycerol concentrations have been developed for use mainly with samples of plasma, where triacylglycerol is in the form of a suspension and therefore suitable for use with the bacterial lipases that are commercially available. The compatibility of the reagents used with this method of hydrolysis with the glycerol assay, suggested that this method may have provided a simple and efficient method of quantification of muscle triacylglycerol. *C. viscosum* lipase activity gave more consistent results than did that from *R. arrhizus*. Reagents with this method did not interfere with the glycerol assay. The lipase was specific for triacylglycerol and no hydrolysis of phospholipid was evident although it may have interfered with triacylglycerol hydrolysis with this method. Homogenising muscles directly in buffer showed that NADH oxidases, ATPases and other elements that are present in muscle, interfered with the hydrolysis or glycerol assay. Alternative colorimetric assays may have been used without the use of NADH or ATP. However, on the basis of other experiments (4 separate experiments where the KOH/OH method was compared with lipase using muscle tissue extracts and triacylglycerol standard) showed that the lipase gave much greater variation in triacylglycerol concentrations. The results with extracted muscle triacylglycerol (Figure 2.8) showed that lipase activity did not completely hydrolyse triacylglycerol. This was attributed to inadequate emulsification. It was concluded that lipase hydrolyses were unsuitable as a method of quantification of muscle triacylglycerol.

Tetraethylammonium hydroxide was simpler to use than the KOH/OH method of chemical hydrolysis as it is specific for triacylglycerol and the silicic acid chromatography step used in the KOH/OH method to remove phospholipid could be omitted on the basis of results given (Figure 2.6). In the muscle extract experiment the variation about the average triacylglycerol concentration was smaller than that with KOH/OH and the tetraethylammonium hydroxide method was the method of choice.

Radioactive recovery of radiolabelled triacylglycerol added to the extraction medium added to muscle before extraction showed that small muscle triacylglycerol concentrations in

earlier experiments may be the result of losses incurred in processing individual muscle strips each weighing ~30mg. In later experiments where volumes of extraction media were increased (and probably greater technical efficiency) showed that the recovery of radioactive counts was >95%.

Control experiments. 48h starvation doubles the triacylglycerol concentration in soleus and heart muscle. The concentrations of triacylglycerol were lower than expected. Denton and Randle (1967) heart from fed rat the triacylglycerol concentration was equivalent to $5.2\mu\text{mol/g}$ wet wt (assuming water content is ~75%) and that from 48h starved rats was $7.0\mu\text{mol/g}$ wet wt (total glyceride of which triacylglycerol is approx. 95%) which is an increase with starvation of 1.3 and alloxan-diabetes increased triacylglycerol concentration 2-fold.

Short term culture of soleus muscle strips with Medium 199 containing palmitic acid showed that incorporation of exogenous fatty acid was apparent within in 1h. Incorporation of palmitic acid was evident in the triacylglycerol fraction of lipids separated by TLC. Care was taken to ensure that no unincorporated fatty acids adhered to the outside of the muscle (washing in fresh Medium 199). This indicates that soleus muscle strips were capable of taking up fatty acids and synthesising triacylglycerol. Most fatty acid taken up remained unesterified and some incorporation into phospholipid was evident. The triacylglycerol concentrations were lower than expected and was probably due to losses in processing not accounted for by radioactive monitoring.

Time course for incorporation of 0.6mM [^3H]-palmitic acid. Since incorporation of exogenous fatty acids was evident at 1h and effects of diabetes or starvation on triacylglycerol metabolism can be found at 24h, the time course for uptake and incorporation of fatty acid *in vitro* was measured using the long term soleus muscle strip culture system developed in this laboratory and described by Stace *et al.* (1990). Muscle strips, incubated with radiolabelled palmitic acid, showed an increase in triacylglycerol concentration reaching a maximum rate of incorporation at 24h incubation. A steady state in the rate of incorporation of palmitic acid was apparent at 15h. (The difference between incorporation at 7h and 15h, and 15h versus 24h are not significant). The results of TLC analysis also shows a clear progress curve for incorporation

of tritiated counts specifically into triacylglycerol with a maximum incorporation at 15h. Tritiated counts could only have come from extracted lipid as samples were washed free of fatty acids adhering to the outside of the muscle strips and extractions (in aqueous washed chloroform extracts) were washed with heptane which removes fatty acids (radioactive counting of heptane washes showed that no radioactivity was detected in the final of three heptane washes. Under the defined conditions of the culture (Medium 199 and oxygen tension) the uptake and incorporation may be limited by an unknown factor. The concentration of labelled fatty acid was sufficient for the duration of the incubation and half way in the incubation media were changed and fresh media applied. These results do not show how the triacylglycerol concentration varies in the muscle with incorporated fatty acid, whether there is net synthesis or turnover of triacylglycerol, and how other respiratory substrates, glucose and acetate, present in Medium 199 affect rates of incorporation or concentrations of triacylglycerol.

Long term culture of soleus muscle strips with 0.6mM [³H]-palmitic acid. 14% of the triacylglycerol content of soleus muscle strips incubated with 0.6mM [³H]-palmitic acid contained incorporated palmitic acid *in vitro* in collated data from 4 separate experiments. Recoveries of radiolabelled triacylglycerol added to the extraction medium show that recovery of radioactivity was almost complete (>95%) and that measured triacylglycerol concentrations were representative of muscle triacylglycerol concentrations. Triacylglycerol concentrations for freshly excised soleus muscle are in good agreement with other reports *e.g.* Wakata *et al.* (1990) Despite incorporation of palmitic acid the triacylglycerol concentration was not increased in comparison with muscles incubated without palmitic acid (in Medium 199), without substrates (no glucose nor acetate - Krebs-Henseleit buffer) or unincubated freshly excised muscle, indicating that there had been no net synthesis but there was triacylglycerol turnover in the incubated muscle. As synthesis had occurred then rates of lipolysis must have been equal with synthesis rates. These rates may have been increased as in starvation or diabetes where plasma fatty acid concentrations are increased, but as with tissues taken from rats with these conditions, lipolysis rates were equally increased. Unfortunately, no real conclusions can be drawn because there are no significant differences in the triacylglycerol concentrations between any group.

(SEMs as percentages of means averaged 12%.)

Effects of adenosine deaminase and 8-phenyltheophylline. The adenosine antagonist, 8-phenyltheophylline has been reported to inhibit cAMP phosphodiesterase in skeletal muscle (Nicholson and Wilke, 1989). Adenosine deaminase also raises the cAMP concentration. cAMP increases triacylglycerol lipolysis by increasing phosphorylation of site 1 which activates hormone sensitive lipase. Soleus muscle strips were also incubated with culture medium containing these agents *in vitro* and although a decrease in mean triacylglycerol concentrations were found, the variations about mean values were too large for differences to be statistically significant and inferences drawn. Abmrad *et al.* (1980) found that incubation of diaphragm (up to 1h) with isoproterenol increased muscle free fatty acid and glycerol concentration and cAMP levels.

In a final experiment triacylglycerol concentrations were measured in 6 freshly excised soleus muscles without freezing in liquid nitrogen. Recoveries were measured with radioactive triacylglycerol tracer and were >95%. The average triacylglycerol concentration (8.2 μ mol/g wet wt) was approx. that expected from other reports for soleus muscle (*e.g.* Wakata *et al.*, 1990). The standard error about the mean value as a percentage of the mean was 21%.

Two possibilities exist that may explain the gross variations in triacylglycerol concentration found even with freshly excised muscle; that methods of measurement of muscle triacylglycerol underestimate the triacylglycerol concentration in some of the muscle strips examined, or that there is natural variation in the triacylglycerol concentrations of rat skeletal muscle. As has been demonstrated, the methods of measurement of muscle triacylglycerol have been rigorously tested. Soleus muscle strips were individually processed. The extraction process resulted in recoveries >95% (at worst 83% in one experiment). Assay of the resulting liberated glycerol by glycerol assay gave 100% recovery of added glycerol.

The only conclusion that can be drawn from these results is that there must exist natural biological variation in triacylglycerol concentrations in skeletal muscle. This finding is confirmed by two other reports that make the same conclusion (with rat soleus and plantaris, Frayn and Maycock, 1985; human leg muscle). Care was taken with the experiments presented here that

variation between animals was minimised by incubating one each of the 4 soleus muscle strips in each condition. To eliminate the possibility that rats may exercise one hind leg more than the other and that this might have a bearing on results was tested in one experiment (results not shown) where only muscles from the right hind legs were utilised which gave similar results. The possibility that the bisection of each soleus muscle into two strips may cause sufficient trauma to the tissue to cause triacylglycerol breakdown in some strips and not others was discounted when whole muscles from younger animals (each muscle weighed ~30mg) were incubated and the variability in triacylglycerol concentrations remained (results not shown). Variation has been found within animals and between animals. Frayn and Maycock (1980) argued that interstitial adipose tissue in the form of cells interleaved with those of the muscle, but Denton and Randle (1967) and Tan *et al.* (1977) thought this unlikely and Tan estimated that 1% of muscle triacylglycerol may be in this form. Triacylglycerol concentrations measured here were small (*e.g.* $8\mu\text{mol.g wet wt}$). If this were all triacylglycerol in adipose tissue this would represent $8/1000$ (the approximate molecular weight of triacylglycerol) or 0.8 per cent of the total weight, and if the density of the triacylglycerol was approx 0.9gml then this would represent $>0.3\mu\text{l}$ in a 30mg muscle strip. If adipose tissue of this size (and this is an overestimate) were impossible to remove. This is irrespective of the need to dissect and prepare soleus muscle strips (usually 4 in each of 4 experimental groups, in each experiment) with the utmost care, to prevent excessive damage to the tissue, and haste to limit loss of integrity. As it was impossible to remove underlying individual adipocytes the project was discontinued.

Chapter 3

Effect of palmitoyl carnitine and of other respiratory substrates on activity of pyruvate dehydrogenase kinase in rat heart mitochondria

INDEX

	Page
Introduction	3.3
Materials and Methods	3.7
1 Materials	3.7
2 Solutions	3.8
3 Spectrophotometric measurement of the concentration of ATP stock solution	3.9
4 Standardisation of palmitoyl L-carnitine solution	3.9
5 Preparation of arylamine acetyltransferase (AAT) enzyme	3.9
6 Rats	3.10
7 Preparation of rat heart mitochondria	3.11
8 Mitochondrial incubations	3.12
9 Activation of PDH complex	3.13
10 Assay of pyruvate dehydrogenase (PDH) complex activity	3.13
11 Assay of PDH kinase activity by ATP dependent inactivation of PDH complex	3.15
12 Deproteinising mitochondrial incubates	3.16
13 Acetyl-L-carnitine assay	3.17
14 Assay of L-carnitine and of palmitoyl-L-carnitine	3.17
15 Pyruvate assay	3.19
16 Succinate assay	3.19
17 Definition of enzyme activity	3.20
18 Expression of results and statistical analysis	3.21
Results	3.22
19 Control experiments	3.22
20 The effect of palmitoyl L-carnitine/L-malate on the activity of PDH kinase in rat heart mitochondria <i>in vitro</i>	3.23
21 The effect of acetyl carnitine/L-malate, α -ketoglutarate/L-malate α -ketoisocaproate/L-malate, pyruvate/L-malate and succinate on the activity of PDH kinase in rat heart mitochondria <i>in vitro</i>	3.25
22 The effect of palmitoyl L-carnitine/L-malate on the activity of PDH kinase in rat heart mitochondria, <i>in vitro</i> under anoxia and in the presence of rotenone	3.27
Discussion	3.28

INTRODUCTION

Evidence was obtained with muscle preparations *in vitro* that starvation and alloxan-diabetes decreases glucose utilization (glucose uptake, phosphorylation, glycolysis and pyruvate oxidation). The idea that this effect might be mediated by enhanced oxidation of fatty acids formed from endogenous muscle triacylglycerol, led to the proposal of the glucose fatty acid cycle (Randle *et al.*, 1963). Oxidation of fatty acids and ketone bodies and the development of diabetes elevates the [acetyl-CoA]/[CoA] in perfused hearts (Randle *et al.*, 1966). High concentration ratios of [acetyl-CoA]/[CoA] and of [NADH]/[NAD⁺] inhibit the PDH complex (Garland and Randle, 1964 a,b) which are also end products of the complete reaction sequence of the complex. The PDH complex is therefore regulated by the concentration ratios of these metabolites. The most important means of regulating the PDH complex is by interconversion between inactive phosphorylated and active dephosphorylated forms catalysed by PDH kinase and PDH phosphatase, respectively (Linn *et al.*, 1969a,b). Wieland *et al.* (1971a,b) showed that oxidation of fatty acids or ketone bodies or alloxan-diabetes also increased phosphorylation of PDH complex. These results indicated that [acetyl-CoA]/[CoA] may also regulate the interconverting enzymes.

Incubation of isolated heart mitochondria with palmitoyl-L-carnitine inhibited pyruvate oxidation (Bremer, 1966). Incubation of mitochondria with respiratory substrates which form acyl-CoA (α -ketoglutarate plus L-malate, succinate, acetyl-L-carnitine plus L-malate, palmitoyl-L-carnitine plus L-malate) were equally effective a decreasing in the proportion of active complex, that is phosphorylation of the complex had increased (Kerbey *et al.*, 1976). It was thought that in general, the phosphorylation of PDH complex was inversely correlated with the concentration of ATP and similar results were found using incubated mitochondria from other tissues (Martin *et al.*, 1972; Whitehouse *et al.*, 1974; Cooper *et al.*, 1974). The mechanism of inhibition of PDH complex by metabolite concentrations ratios has been shown to be the result of reductive acetylation of lipoate (see chapter 1) leading to the formation of E1.TPPhydroxyethyl carbanion. The PDH kinase activity has also been shown to be affected by an increase in the

mitochondrial ratio of [acetyl-CoA]/[CoA] and possibly of [NADH]/[NAD⁺] through reductive acetylation of lipoate (Ravindran *et al.*, 1996).

However, some results reported by Kerbey *et al.* (1976) did not show the expected increase in ATP concentration with increasing palmitoyl-L-carnitine plus L-malate concentration despite decreasing PDH complex activities. Lower proportions of active complex were found in mitochondria prepared from alloxan-diabetic rat hearts and incubated with α -ketoglutarate plus malate compared with mitochondria incubated with the same substrates but prepared from non-diabetic rats and indicated that there may be further mechanisms of activation of the kinase. These mechanisms were stable and persisted through the procedure to isolate mitochondria. Using preparations of purified PDH complex from pig hearts which contain intrinsic kinase (PDH kinase tightly binds to the complex core and copurifies with it), it was found that the kinase activity is regulated as follows; NADH activates, NAD⁺ reverses this activation, acetyl-CoA activates in the presence of NADH and NAD⁺ and CoA inhibits in the presence of NADH and NAD⁺ (Kerbey *et al.*, 1976). The concentration ratios of these metabolites measured in mitochondrial incubations with palmitoyl-L-carnitine showed that an increased ratio of [acetyl-CoA]/[CoA] was associated with a diminution in the proportion of active (dephosphorylated) PDH complex in the absence of any increase in the ratio of [ATP]/[ADP] or of [NADH]/[NAD⁺] (Kerbey *et al.*, 1977). This discovery established that there is a further stable mechanism which either activated PDH kinase and/or inhibits PDH phosphatase.

Assays performed on extracts of heart mitochondria showed that the rate of ATP-dependent inactivation of PDH complex or of incorporation of ³²P from [γ -³²P]ATP was increased 2-3 fold relative to controls in extracts of mitochondria from starved or diabetic rats (Hutson and Randle, 1978; Fuller and Randle, 1984) (also in mammary gland mitochondria; Baxter and Coore, 1978). The stability of the effect which survives separation of mitochondria, incubation of mitochondria at 30 °C and extraction suggested either an increase in the concentration of the kinase or a stable activator, or covalent modification of kinase or stable activator.

It was possible to separate from PDH complex in mitochondrial extracts as a fraction that

enhanced the PDH kinase activity of highly purified pig heart PDH complex (which contains intrinsic PDH kinase) (Kerbey and Randle, 1981). Separation can be achieved by either centrifugation (150 000g) or gel filtration (Sephadex S300). The activity of the protein fraction was increased 2-3 fold by starvation or alloxan-diabetes. The maximal velocity of the reaction was increased, whilst the concentration for half-maximal activation remained the same, and suggested that starvation increases the specific activity of the kinase activator protein (Denyer *et al.*, 1986; Randle *et al.*, 1984). There is now substantial evidence that this kinase activator protein is a free PDH kinase (Mistry *et al.*, 1991). (This work was conducted using rat liver mitochondria as the total yield per rat is much greater than that from heart and as the regulation of rat liver PDH kinase is very similar to that in heart the results are thus likely to be applicable to that in heart.) Purification of kinase activator protein to apparent homogeneity determined by SDS-PAGE and N-terminal sequencing, showed that kinase activator protein was 4.5 fold greater in specific activity than that from fed animals (Priestman *et al.*, 1992). Confirmation that the specific activity of PDH kinase was increased with starvation (and a small increase (15 per cent) the concentration of the enzyme), came from enzyme-linked immunosorbent assay (ELISA) made from polyclonal antibodies raised against the free kinase (Priestman *et al.*, 1994).

The effect of starvation to increase the activity of PDH kinase could result from two isozymes of PDH kinase which differ in specific activity or the increased specific activity of a single kinase.

Other studies in this laboratory have shown that agents which increase cAMP (dibutyryl cAMP or glucagon), or fatty acids (n-octanoate or palmitic acid bound to albumin) added to cultured hepatocyte or cardiac myocytes or soleus muscle strips in culture, all increase PDH kinase activity (Fatania *et al.*, 1986; Marchington *et al.*, 1989, 1990; Stace *et al.*, 1992). Cultured hepatocytes were incubated with cAMP \pm cyclohexamide, or with palmitate \pm Etomoxir (an inhibitor of carnitine acyltransferase I). The results showed that protein synthesis is needed for the cAMP effect and that carnitine acyltransferase I is required for the palmitate effect to increase PDH kinase activity (Priestman *et al.*, 1994). It has been concluded that starvation, cAMP and palmitate must modify the structure of PDH kinase. One possibility is that cAMP

induces synthesis of a protein which catalyses a reaction between palmitate and PDH kinase (*e.g.* acylation).

The objective of the experiments presented here was to ascertain whether the increase in PDH kinase put into effect by palmitate in cultured cardiac myocytes could be reproduced in rat heart mitochondria with palmitoyl carnitine; and, if so, to compare the effect with that of other respiratory substrates. Briefly, mitochondria were isolated from hearts of 48h starved and fed rats and incubated for up to 60min in KCl medium \pm respiratory substrates and PDH kinase activities measured. The respiratory substrates chosen were succinate (alone); and palmitoyl carnitine, α -ketoglutarate, α -ketoisocaproate, pyruvate, or acetyl-carnitine each with L-malate.

MATERIALS and METHODS

1 Materials

All chemicals used were of the highest grade available and were purchased from BDH Chemicals Ltd, Poole, Dorset with the following exceptions. Anaesthetic Pentobarbitone Sodium B.P. 60 mg/ml in 9 per cent ethanol (v/v) as a preservative (Sagatal®) was purchased from Veterinary Drug Co Ltd, Unit 8, Lakeside Ind Est, Colnbrook, Slough, Berks UK. p-(p-Aminophenylazo)benzene sulphonic acid (AABS) was from Kodak U.K. Ltd. NAD⁺ (free acid), β-NADH (disodium), CoA (free acid), bovine serum albumin free of fatty acids (BSA ffa), ATP (disodium salt), carnitine acetyltransferase [(NH₄)₂SO₄ suspension] from pigeon breast muscle and succinate thiokinase [(NH₄)₂SO₄ suspension] from pig heart, L-lactate dehydrogenase (LDH) type II from rabbit muscle [(NH₄)₂SO₄ suspension], pyruvate kinase (PK) type II from rabbit muscle [(NH₄)₂SO₄ suspension] were purchased from Boehringer Mannheim UK Ltd, Bell Lane, Lewes, East Sussex. Thiamine pyrophosphate (chloride) (TPP), protease type XXVI (Nagarse), oligomycin B, acetyl-DL-carnitine (hydrochloride), palmitoyl-L-carnitine (chloride), monosodium L-malate (salt), L-carnitine (inner salt), acetyl CoA (sodium salt), sodium pyruvate, disodium succinate (hexahydrate), DL-dithiothreitol, benzamidine hydrochloride (hydrate), leupeptin hemisulphate, N-α-p-tosyl-L-lysine chloromethyl ketone hydrochloride (TLCK), carbonyl cyanide m-chlorophenylhydrazone (CCCP), 5'-adenylylimidodiphosphate (lithium salt) (AMP-PNP), guanosine 5'-triphosphate (type III free acid) (GTP), phosphoenol pyruvate (tris cyclohexylammonium salt), β-mercaptoethanol, sodium α-ketoisocaproate (sodium 4-methyl-2-oxopentanoate), monopotassium-α-ketoglutarate and rotenone were all purchased from Sigma Chemical Co Ltd, Fancy Road, Poole, Dorset, UK. 5,5'-dithiobis (2-nitrobenzoic acid) (DTNB) was purchased from Aldrich Chemical Company Ltd, The Old Brickyard, New Road, Gillingham, Dorset UK. All chemicals, biochemical and enzymes were stored in accordance with the manufacturers' instructions.

Pigeons were from surplus stock local pigeon fanciers and were well nourished.

Whatman no 4 filter paper was supplied by Whatman Ltd, Springfield Mill, Maidstone.

Kent, UK. pH test strips were bought from Sigma Chemical Co as above.

2 Solutions

All solutions were made with distilled water unless otherwise indicated. Stock solutions to make the solutions used to isolate, incubate and extract mitochondria were stored in glass bottles at 4°C. These were 0.5M-EDTA pH 8.0, 0.5M-EGTA pH 8.0, 1M-MgCl₂, 1M-KCl, 1M-KH₂PO₄ pH 7.0, and 1M-Tris-HCl pH 8.0. Buffered sucrose (250mM-sucrose/ 5mM-Tris/ 2mM-EGTA/pH 7.4 at ~2°C was prepared fresh for each experiment. KCl medium for incubation of mitochondria (composition 120mM-KCl/ 20mM-Tris/ 5mM-EGTA/ 5mM-KH₂PO₄; adjusted to pH 7.4 at room temperature) was freshly made on day of use from stock solutions). CCCP stock solution (10mM in absolute ethanol) was stored at -20°C and diluted with KCl medium to 10μM on the day of use. Mitochondrial extraction buffer (50mM-KH₂PO₄/ 10mM-EGTA/ 2mM-DTT/ 1mM-MgCl₂/ 0.5mM-TLCK/ 1mM-benzamidine/ 10μM-leupeptin) was adjusted to pH 7.0 at room temperature, and 8ml aliquots stored frozen at -20°C. Oligomycin B was diluted to 5mg/ml with absolute ethanol and stored at -20°C. It was added to mitochondrial extraction buffer to 31μg/ml on the day of use. PDH complex assay buffer (PABF) (100mM-Tris/ 1mM-MgCl₂/ 0.5mM-EDTA/ 5mM-NaF) was prepared from stock solutions and adjusted to pH 7.8 at 30°C and stored at 4°C. On the day of use β-mercaptoethanol was added to 5mM and AABS stock (1mg/ml) added to a final concentration of 20μg/ml. A mixture of the additions to PABF required for the assay of PDH complex activity (72mM-TPP, 36mM-NAD⁺ and 7.2mM-CoA) were made and stored in 1ml aliquots at -20°C. ATP was made 10mM (gravimetric measurement, see spectrophotometric measurement of concentration of ATP), aliquoted and stored frozen at -20°C. Fresh aliquots were used for each day's analyses. Rotenone stock solution was prepared by dissolving 0.75mg rotenone in ml absolute ethanol and stored at -20°C.

3 Spectrophotometric measurement of the concentration of ATP stock solution

ATP stock solutions were standardised by measurement of $\epsilon_{257\text{nm}}$ in 1N-HCl in a quartz cuvette. The concentration of the ATP solution was calculated from the absorbance (against air and a blank reading for the absorbance due to the cuvette and HCl) and the mM-extinction coefficient for ATP of 14.4cm^{-1} .

4 Standardisation of palmitoyl-L-carnitine solution

An approximately 10mM stock solution of palmitoyl carnitine was prepared with extraction buffer (50mM- KH_2PO_4 / 10mM-EGTA/ 2mM-DTT/ 1mM- MgCl_2 / 0.5mM-TLCK/ 1mM-benzamidine/ $10\mu\text{M}$ -leupeptin at pH 7.0) and diluted in 10 ml KCl incubation buffer, in a glass vessel, to a final gravimetric concentration of $50\mu\text{M}$ as was customary for mitochondria incubated in this medium. 10M-KOH was added to a final concentration of 200mM and the vessel capped and placed in a water bath at 55°C . The sample was heated for 1.75h swirling approx. every 10min and then placed on ice. When cool 1M-Tris (pH 8.0) was added to a final concentration of 150mM and the sample pH adjusted to 8.0 with concentrated perchloric acid and the extract clarified by centrifugation at room temperature for 3min at 500g (IEC centra-4B bench top centrifuge). The supernatant was assayed for carnitine (see section 14, Assay of L-carnitine) Stock palmitoyl carnitine was also assayed for free carnitine.

5 Preparation of arylamine acetyltransferase (AAT) enzyme

Arylamine acetyltransferase was prepared by a modification of the method of Tabor *et al.* (1953) as follows.

Preparation of pigeon liver acetone powder: Pigeons were killed by cervical dislocation and livers immediately excised and homogenised in cold (-10°C) acetone using a polytron PT10-35 homogeniser and large aggregate (position 5). and for the minimum time required to effect dispersion. Homogenates were vacuum filtered and the filtered powder washed with acetone followed by diethyl ether. The powder was allowed to dry at room temperature and stored at -80°C until required for use.

Preparation of arylamine acetyltransferase from pigeon liver acetone powder Pigeon liver acetone powder (10g) was added to 100ml of ice cold distilled water and homogenisation initiated with a Polytron PT10-35 tissue homogeniser (large aggregate, at position 5 for 1min). The suspension was allowed to cool on ice for 1min before rehomogenising (Polytron) as before. The suspension was centrifuged for 10min at 4°C (MSE 18; 8 x 50 ml fixed angle rotor, 17 000g). The supernatant was decanted and kept on ice. The pellet was re-extracted with 100ml ice cold water and centrifuged as before. The two supernatants were combined and placed in a glass beaker in a salt ice mix and stirred with a magnetic bean and stirrer unit. Cold (-20°C) acetone was added dropwise to a final concentration of 67% (vol/vol). (Care was taken to avoid local high concentrations of acetone as acetone concentration is crucial for successful fractionation). The mixture was centrifuged (MSE 18; 6 x 300 ml fixed angle rotor at 23 000g; 10min at -10°C) and the pellet discarded. Cold acetone (50ml) was added to the supernatant dropwise and the mixture centrifuged as before. A further 100ml of cold acetone was added dropwise to the supernatant and the mix centrifuged again as before and the supernatant discarded. The resulting pellet was resuspended in approx. 3 ml extraction buffer (50mM-KH₂PO₄/ 10mM-EGTA/ 2mM-DTT/ 1mM-MgCl₂/ 0.5mM-TLCK/ 1mM-benzamidine/ 10µM-leupeptin at pH 7.0). The activity of AAT was determined spectrophotometrically by measurement of the rate of acetylation of p-(p-amino-phenylazo) benzene sulphonic acid (AABS) from the rate of decrease in absorbance at 460nm. To a cuvette was added 1.4ml-PABF (100mM-Tris/ 1mM-MgCl₂/ 0.5mM-EDTA/ 5mM-NaF/ 5mM-β-mercaptoethanol at pH 7.8) containing AABS 20µg/ml-PABF and 20µl of acetyl CoA (final concentration 0.2mM), mixed and absorbance recorded at 30°C. The concentration of AAT was calculated from the rate of decrease in absorbance and the mM extinction coefficient for AABS of 6.5 cm⁻¹ allowing for dilutions. The enzyme was diluted further such that 10µl contained 75mU, and divided into 1ml aliquots and stored frozen at -20°C. The yield ranged from 4-6U/g of acetone powder.

6 Rats

Rats used were male albino Wistar weighing 300-400g, supplied by Harlan Olac, Shaws

Farm, Blackthorn, Bicester, Oxfordshire OX6 0TP. Rats arrived at animal house weighing 275-299g each and used after a settling in period of one week. They were held in the Infirmary animal house and had free access to food ('Aged rat and mouse diet' from Bantin and Kingham Limited, The Field Station, Grimston Aldbrough Hull, N. Humberside HU11 4QE) and water. Starved rats were deprived of food but not water for 48h prior to use.

7 Preparation of rat heart mitochondria

In most experiments recorded in this chapter rat heart mitochondria were isolated using the protease Nagarse and differential centrifugation, based on the method given by Chappell and Hansford (1978). Mitochondria were isolated from hearts using Nagarse because it had been found in an earlier study to minimise oligomycin insensitive ATPase in mitochondrial extracts (Hutson & Randle, 1978).

Rats were anaesthetised with an intraperitoneal injection of sodium pentobarbitone or Sagatal® (4ml/kg of body weight). An incision was made to the lower abdomen and cut toward the head through the rib cage. Beating hearts were excised from the body cavity and immediately submerged in ice cold sucrose buffer (250mM-sucrose, 5mM-Tris and 2mM-EGTA at pH 7.4 when ice cold.) Most blood was washed away by this. The heart chambers were opened by a cruciform cut through most of the tissue, blotted on Whatman no 4 filter paper to remove excess blood, and trimmed of large blood vessels and fat. After rinsing by resuspension/ settling under gravity to remove residual blood it was chopped finely in a small volume of sucrose buffer. Protease solution was added to 2.5mg/heart in 6.67ml of sucrose buffer/heart. At 2min the mixture was homogenised using a glass teflon motor driven homogeniser (7 passes at medium speed). (This operation requires some strength and caution). The homogeniser was rinsed with 3.33ml sucrose buffer/heart and placed on ice for a further 12min. At this time the mixture was homogenised again with just two strokes at medium speed, diluted with sucrose medium to approximately 20ml/g of heart and centrifuged at 10 000g, for 9min at 4°C (MSE 18; 8 x 50ml fixed angle rotor). The supernatant (containing protease) was discarded and the pellet was resuspended in the same volume of sucrose medium using the homogeniser, 2 passes at medium

speed. The mixture was centrifuged again as before. The supernatant was discarded, the pellet resuspended as before and the sample centrifuged for 9min at 500g. The supernatant (containing mitochondria) was collected in a fresh centrifuge tube and kept on ice. The loose pellet was resuspended and centrifuged at 500g as above. The supernatants were combined and centrifuged at 10 000g for 9min at 4°C using the MSE 18 centrifuge. The supernatant was discarded and 5ml of sucrose buffer very gently washed over the surface of the mitochondrial pellet, swirled briefly and discarded (to wash away contaminating non-mitochondrial proteins). The pellets were resuspended using a mini glass rod and a small volume of sucrose medium (the mini glass rod was actually a Pasteur pipette with a sealed curved tip). Mitochondria were centrifuged at high speed as before. The resulting pellet was resuspended in KCl incubation buffer (approx. 1ml/1-2 hearts).

Pre-incubation Isolated mitochondria in KCl medium (see above) were pre-incubated (10 min, 30°C, aeration by gentle swirling every 20s) to effect conversion of inactive (phospho-) PDH complex into active (dephospho-) PDH complex.

Assessment of purity The purity of mitochondria following isolation from rat hearts was assessed by measuring the specific activity of PDH complex (munits/mg protein). A sample of 25 μ l of mitochondria was added to 75 μ l of extraction buffer (50mM-KH₂PO₄/ 10mM-EGTA/ 2mM-DTT/ 1mM-MgCl₂/ 0.5mM-TLCK/ 1mM-benzamidine/ 10 μ M-leupeptin at pH 7.0) and rapidly frozen in liquid nitrogen and thawed three times. PDH complex activity and protein concentration (Gornall *et al.*, 1949) of the sample was measured. Mitochondrial preparations generally had specific activities of approx. 100mU-PDH complex activity/mg mitochondrial protein.

8 Mitochondrial incubations

Incubation media were freshly prepared daily and their composition is as given in Table 3.1. Incubations were in 50ml centrifuge tubes in a water bath at 30 °C. After temperature equilibration (5min) mitochondria were added to give a concentration of 200mU-PDH complex/ml (unless otherwise stated) and the tubes capped. Mitochondria were incubated for the

Table 3.1 Composition of mitochondrial incubation media.

KCl Incubation medium	Concentration	
	Stock	Final
50μM-Palmitoyl-L-carnitine/0.1%-fatty acid free BSA/0.5mM-L-malate		
palmitoyl-L-carnitine	5mM	50 μ M
fatty acid free BSA	10%	0.1%
L-malate	25mM	0.5mM
5mM-Succinate		
succinate	100mM	5mM
5μM-α-Ketoglutarate/0.5mM-L-malate		
α -ketoglutarate	250mM	5mM
L-malate	25mM	0.5mM
5μM-α-Ketoisocaproate/0.5mM-L-malate		
α -ketoisocaproate	250mM	5mM
L-malate	25mM	0.5mM
0.5mM or 5mM-Acetyl-DL-carnitine/0.5mM-L-malate		
acetyl-DL-carnitine	25mM	0.5mM or 5mM
L-malate	25mM	0.5mM
50μM-Pyruvate/0.5mM-L-malate		
pyruvate	5mM	50 μ M
L-malate	25mM	0.5mM

Stock solutions were freshly made in KCl incubation medium. First KCl medium was added to a centrifuge tube followed by slow additions of stock solutions according to the table above, the solution swirled gently and lastly mitochondria were added and the incubation placed in a water bath at 30°C. Specific details are given in the text and with particular experiments.

length of time indicated in Tables and Figures and were aerated by gently swirling at 5min intervals.

9 Activation of PDH complex

After incubation mitochondria were separated by centrifugation (MSE 18; 8 x 50ml fixed angle rotor at 10 000g for 7-8min at 4°C) and supernatants removed and either discarded or stored frozen at -10°C for later analysis. Pellets were resuspended gradually (mini glass rod - see section 7 of this chapter) employing 100µl aliquots of KCl medium/ 10µM CCCP to 1ml, and the 1ml aliquots were then further diluted with swirling to give a concentration of PDH complex of 200mU/ml. Sample tubes were then incubated (water bath) at 30°C for 30min and gently swirled every 5min. Following CCCP incubation 1ml samples were added to 1.5ml cryotubes, rapidly centrifuged (Eppendorf centrifuge; at 13 000g at room temperature for a maximum of 30s), supernatants quickly aspirated by suction (water pump) and the pellets frozen immediately and kept in liquid nitrogen.

10 Assay of pyruvate dehydrogenase (PDH) complex activity

Preparation of mitochondrial extracts Mitochondrial pellets held in liquid N₂ were thawed into 50 or 100µl extraction buffer (50mM-KH₂PO₄/ 1mM-EGTA/ 2mM-DTT/ 1mM-MgCl₂/ 0.5mM-TLCK/ 1mM-benzamidine/ 10µM-leupeptin at pH 7.0) at 30°C (water bath) and dispersed by repeated aspiration and ejection with a 100µl Hamilton syringe. Extraction was completed by further alternate rapid freezing/thawing (liquid N₂/ 30°C water bath) x2. The extracts were held in liquid nitrogen after the final freeze until use.

Assay of PDH complex activity The general reaction for the PDH complex reaction is as follows where PDHC is PDH complex:-

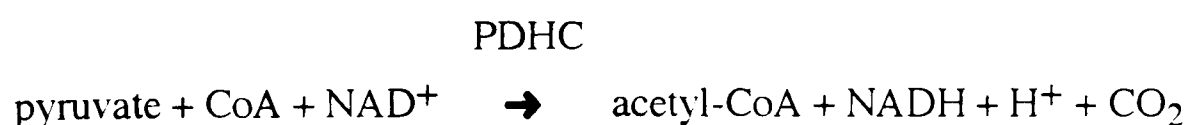

The PDH complex reaction with samples of purified PDH complex free of lactate dehydrogenase (LDH) can be followed spectrophotometrically by monitoring NADH formation at 340nm. In

experiments with crude mitochondrial extracts contamination with LDH and NADH oxidase is expected and in the presence of pyruvate both contaminants will oxidise NADH, and assays based on NADH formation are therefore invalid. By incorporating a second enzyme - arylamine acetyltransferase (AAT) appearance of the acetyl-CoA generated in the PDH complex reaction can be followed by a coupled reaction. AAT catalyses acetylation with acetyl-CoA of the yellow dye p-(p-aminophenylazo)benzene sulphonic acid (AABS) with and the resulting decolourisation can be followed by the decrease in absorbance at 460nm. PDH complex activity can be measured employing a saturating concentration of AAT (Coore *et al.*, 1971). Thus the activity of PDH complex from mitochondrial extracts can be indirectly measured as the rate of decrease in absorbance at 460nm, provided that activity of PDH complex is rate limiting in the overall reaction. In what follows this was achieved by employing concentrations of AAT in excess of those required for V_{max} (75munits AAT in the cuvette; the saturating concentration as experimentally determined was below 50munits AAT; see also Kerbey *et al.*, 1977).

To a cuvette was added 2 μ l of (9mM-CoA + 35mM-NAD⁺ + 78mM-TPP) representing (in 1.475ml) final concentrations of 122 μ M CoA, 475 μ NAD⁺, 1.06mM TPP in a final cuvette volume of 1.475ml. Other additions were 10 μ l 75mU-AAT; mixed with 1.4 ml-PABF [100mM-Tris/ 1mM-MgCl₂/ 0.5mM-EDTA/ 5mM- β -mercaptoethanol containing 20 μ g/ml AABS; pH 7.8 at 30°C; (and in kinase assays only - 50mM-NaF)] and typically 5-25 μ l of mitochondrial extract added. The reaction was started by adding 20 μ l 73mM-pyruvate (final concentration ~1mM) with thorough mixing and followed with a Gilford Instruments UV/VIS spectrophotometer 250 and Servoscribe Is RE 541.20 potentiometric recorder set at 1cm/min and a full scale absorbance of 0.1. The activity of PDH complex was calculated from the linear steady state rate of decrease in absorbance (attained after approx, 1-1.5min) and the mM extinction coefficient for AABS at 460nm of 6.5cm⁻¹. By definition 1mU-PDH complex converts 1 μ mol of AABS to acetyl-AABS per min at 30°C. The AAT assay is not subject to end product inhibition because both products are removed (by oxidation and AAT respectively).

11 Assay of PDH kinase activity by ATP dependent inactivation of PDH complex

PDH kinase was assayed in extracts prepared from mitochondria in which phosphorylated (inactive) PDH complex had been converted into active (dephosphorylated) complex by incubation with CCCP. PDH kinase activity was calculated from measurements of the rate of ATP dependent decrease in PDH complex activity at a MgATP concentration computed to give >90 per cent V_{max} . The concentration of ATP was 0.5mM which under the conditions of assay corresponded to 0.24mM-MgATP (see following paragraph). This is approximately $11 \times K_m$ which for rat heart PDH kinase is $\sim 22\mu\text{M}$ -MgATP; Cooper *et al.*, 1974). Because inactivation is due largely to phosphorylation of a single site in the E1 component of the complex - site 1 (>94 per cent; Sale & Randle, 1981, 1982) and because the E1 component is rate limiting in the holocomplex reaction, it is valid and convenient to compute PDH kinase activity as the pseudo first order rate constant. Proteolysis is capable, potentially, of producing inactivation without phosphorylation. In practice this was avoided by inclusion of protease inhibitors but it is important to exclude proteolysis by control incubations in the absence of ATP. Such controls were run with each batch of mitochondria and extraction medium. They were always negative, *i.e.* there was no inactivation in the absence of ATP.

PDH phosphatase is present in mitochondrial extracts and if active will interfere with the kinase assay by catalysing dephosphorylation and reactivation. PDH phosphatase requires Mg^{2+} ($K_m \sim 0.5\text{mM}$) and in the presence of Mg^{2+} is activated by Ca^{2+} ($K_m \sim 1\mu\text{M}$) (Severson *et al.*, 1974), *i.e.* free $[\text{Mg}^{2+}]$ and $[\text{Ca}^{2+}]$ must be low to minimise PDH phosphatase activity. This was achieved in practice by the inclusion of 10mM-EGTA in the extraction buffer (to remove Ca^{2+}) and by adding ATP at 0.5 mM and Mg^{2+} at 1 mM to the PDH kinase assay. Computed values for the concentrations of MgATP and free Mg^{2+} were $240\mu\text{M}$ and $48\mu\text{M}$ respectively (this takes into account 50mM potassium phosphate present in the extraction buffer and the conditions of the PDH kinase assay). Lastly ADP is a competitive inhibitor of PDH kinase (K_i $70\mu\text{M}$; Cooper *et al.*, 1974) and may be formed by mitochondrial ATPases; this was minimised by the inclusion of oligomycin B ($31\mu\text{g/ml}$) in the PDH kinase assay medium.

Practical details of PDH kinase assays were as follows. Frozen mitochondrial pellets were thawed into and extracted with 50 or 100 μ l extraction buffer (50mM-potassium phosphate/ 10mM-EGTA/ 2mM-DTT/ 1mM-MgCl₂/ 0.5mM-TLCK/ 1mM-benzamidine/ 10 μ M-leupeptin/ 31 μ g/ml oligomycin B: pH 7.0), frozen, thawed, and finally held frozen in liquid nitrogen (*i.e.* extraction was achieved by freezing and thawing x3). A tube was thawed and the concentration of PDH complex in the extract measured (see section 10 Assay of PDH complex activity). Extracts were then thawed and diluted as required to yield a final PDH complex concentration in the assay of 300mU/ml and equilibrated to 30°C in a water bath for 2min. At zero time ATP was added to yield final concentrations of 0.5mM-ATP (and 300mU/ml of PDH) and whirlimixed. Aliquots (25 μ l) were added to PDH complex assay reagents (minus pyruvate) at intervals such that approximately 75% inactivation of PDH complex activity was achieved by the final fourth time point. The PDH assay buffer contained 50mM-NaF to inhibit PDH phosphatase and thereby to prevent conversion of PDHb to PDHa in the cuvette). Pyruvate was then added to the cuvettes and the assays of PDH complex activity completed. The spectrophotometer and chart recorder were set to record the absorbance of each of the four cuvettes for 1s at 3s intervals and relative PDH complex activities were computed from the traces (A_0 , A_{t_1} , A_{t_2} , A_{t_3}). PDH kinase activities were calculated as the apparent first order rate constants (k ; min⁻¹ \pm SEM) given by the equation: $-\ln(A_t/A_0) = -kt$; k was computed as the slope \pm SEM from least squares linear regression analysis of $\ln(A_t/A_0)$ on t (Kerby and Randle, 1981). Correlation coefficients were computed and were in excess of 0.95.

12 Deproteinising mitochondrial incubates

Following incubation, mitochondria samples were centrifuged (see 9 Activation of PDH complex Post incubation) and the supernatants collected. These supernatants were deproteinised by adding samples to 60 per cent HClO₄ to a final concentration of approx. 100mM-HClO₄, mixed (whirlimixer) and cooled on ice. Samples were centrifuged (eppendorf centrifuge, room temperature, 13 000g for 30s). Supernatants were carefully removed with needle and syringe and added to 0.25volumes of 1M-Tris-HCl buffer pH 7.5 to buffer the solution, neutralised with

10M-KOH, mixed, cooled on ice and centrifuged as before. Supernatants were further processed according to the method used to assay the particular substrate.

13 Acetyl-L-carnitine assay

Acetyl-carnitine was measured in deproteinised samples of incubation media taken from mitochondrial incubations. (See 12 Deproteinising of mitochondrial incubates). The principle is given by the equations:-

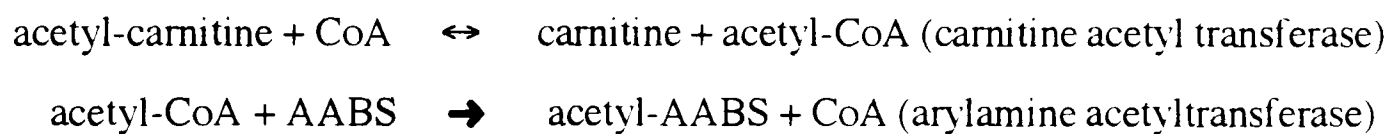

Thus, the concentration of acetyl-carnitine is determined by the decrease in absorbance of AABS at 460nm.

Practical details were as follows; 75mU-AAT, 1.4ml of PABF (100mM-Tris/ 1mM-MgCl₂/ 0.5mM-EDTA/ 5mM-β-mercaptoethanol/ 50mM-sodium fluoride at pH 7.8) containing AABS to 20μg/ml, and 50μl of CoA, final concentration 35μM) were added to each cuvette, followed by 10μl of sample, mixed and the absorbance monitored by a spectrophotometer and chart recorder (full scale deflection of 0.2, speed 2cm/min). When the absorbance plateaued it was noted (Abs1), 10μl of carnitine acetyltransferase was added to (final concentration 600mU/ml), mixed and the second absorbance recorded at the plateau (Abs2), (approximately 5min). The concentration of acetyl-carnitine in samples was calculated from the absorbance difference (Abs2-Abs1) and the extinction coefficient for AABS of 6.5 mM⁻¹cm⁻¹ allowing for blanks and dilutions.

14 Assay of L-carnitine and of palmitoyl-L-carnitine

L-Carnitine was measured in samples deproteinised as in section 12 and then ether extracted by shaking with 4vol ether (water saturated) for 1min and the ether aspirated with a Pasteur pipette (this was to remove palmitate and palmitoyl carnitine).

Carnitine was measured as the CoA released from acetyl-CoA using the DTNB method given in Pearson *et al.* (1974). The principle is given below.

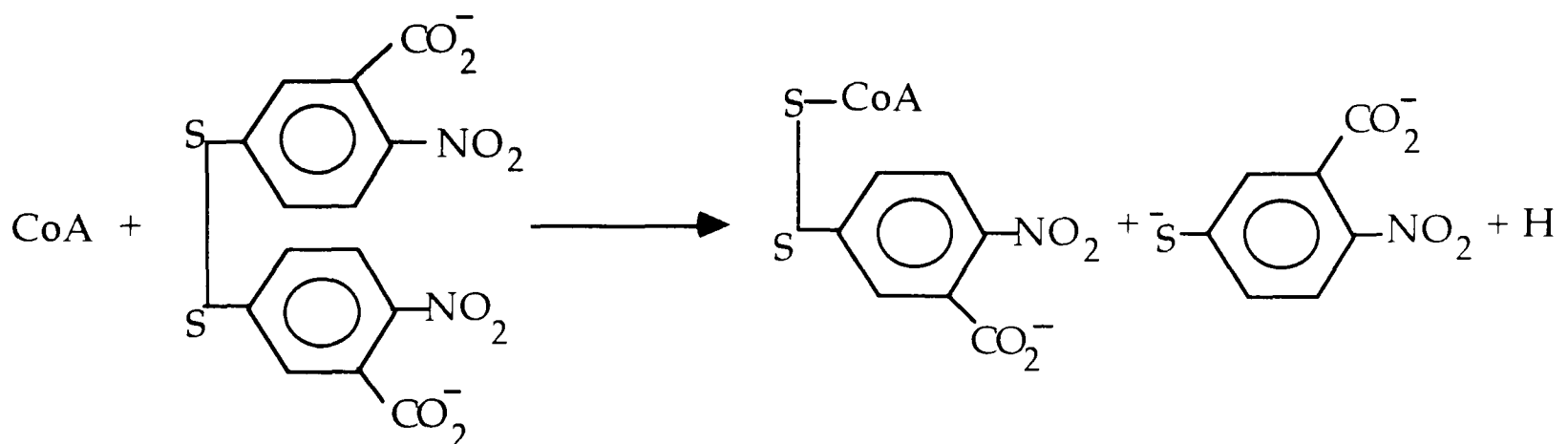
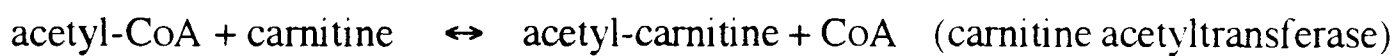

The carnitine acetyltransferase reaction is reversible but the CoA formed is removed non-enzymatically by reaction with DTNB to displace the reaction in favour of products and produces a yellow 5-thio-2-nitrobenzoate anion which strongly absorbs at 412nm. Typically 0.5ml samples were added to cuvettes containing 1ml 200mM-Tris, pH 8.0 (incorporating 20 μ l of 10mM-DTNB (in 2 per cent NaHCO₃), and 20 μ l of 10mM-acetyl-CoA. After mixing the change in absorbance was recorded at 412nm at room temperature and the final stable reading noted (Abs1). (The chart recorder was set at full scale deflection of 0.3 and run at 2cm/min and used to determine when reaction was complete - the actual absorbance readings were taken directly from the spectrophotometer). Carnitine acetyltransferase was added to a final concentration of 600mU/ml, mixed and when the absorbance reading was steady (typically within 5min) the absorbance (Abs2) was recorded. The concentration of carnitine in samples was calculated from the difference in absorbance (Abs2-Abs1) and the mM extinction coefficient for DTNB of 13.6cm⁻¹, allowing for blanks and dilutions of measurement and processing. The measurement was made against air. Absorbances were stable for at least 30min. Standard solutions of the naturally occurring L- isomer of carnitine were made fresh for each experiment and used to check assay reagents before assaying samples; recoveries were invariably >95 per cent.

15 Pyruvate assay

Pyruvate was measured in deproteinised samples of incubation media taken from mitochondrial incubations. (See 12 Deproteinising of mitochondrial incubates). The principle of the method is given in the diagram pyruvate being measured by:

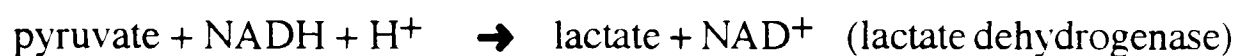

The change in absorbance at 340nm due to disappearance of NADH. (Under the conditions of assay with excess NADH the reaction is essentially complete).

Practically, to a cuvette was added 1.4ml of 350mM-Tris pH 8.0, 25 μ l of NADH to a final concentration of 64 μ M, and 5 μ l or 30U-LDH stock. The cuvette contents were mixed and the absorbance reading taken from the spectrophotometer when the chart recorder trace was steady which was set at 1min/cm and a full scale deflection of 0.4. A suitable volume of sample was added to the cuvette, mixed and the second absorbance reading taken when the chart recorder indicated a steady reading (approx. 5min later). The concentration of pyruvate in samples was calculated from the absorbance difference and the mM extinction coefficient for NADH of 6.22 cm⁻¹ allowing for blanks and dilutions of measurement and deproteinising. The measurement was made against air. Standard pyruvate solutions were made and used to check the purity of pyruvate and the recovery following deproteinisation. Recoveries were >95 per cent.

16 Succinate assay

Succinate was assayed in deproteinised samples (see 12 Deproteinising of mitochondrial incubates) of incubation media taken from mitochondrial incubations. The method used to measure succinate was given by Williamson (1974). The principle is given below:

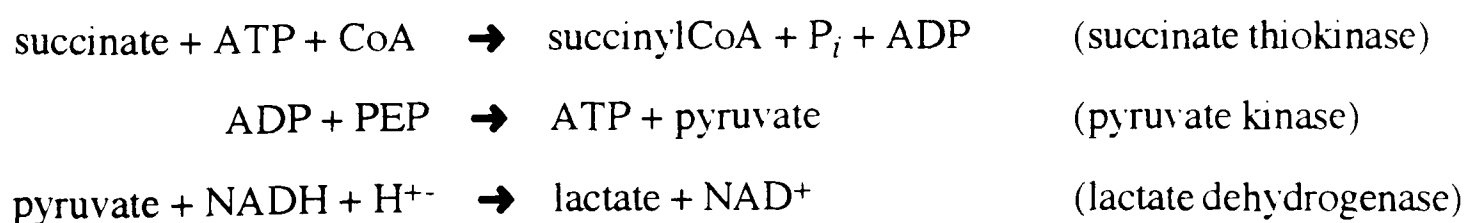

Succinate thiokinase catalyses the phosphorolytic cleavage of succinyl-CoA by GDP. This is a reversible reaction, but the equilibrium can be displaced in favour of succinyl-CoA formation from succinate by coupling with the pyruvate kinase and lactate dehydrogenase reactions. The amount of succinate is then given by the decrease in absorbance at 340 nm as NADH is oxidised to NAD⁺.

Practically, 2ml of 100mM-Tris pH 7.0 /10mM-MgCl₂/ 5mM-EGTA/ 5mM-β-mercaptoethanol was added to each cuvette followed by 250μl of sample. Then 20μl of CoA/GTP/PEP mix (final concentrations 45μM, 90μM and 450μM respectively), 50μl of β-NADH (final concentration 50μM), and 10μl of LDH/ pyruvate kinase mix (final concentrations 5U/ml and 1500mU/) were added to each cuvette. The cuvette contents were mixed and the absorbance monitored on a chart recorder set at 5min/cm and a full scale deflection of 0.4. When the reaction was steady the absorbance was noted from the spectrophotometer. Succinate thiokinase was then added to a final concentration of 210mU/ml, the reactants mixed, and the absorbance change followed until steady (typically 30min after the addition of succinate thiokinase). The concentration of succinate in samples was calculated from the absorbance change and the mM extinction coefficient for NADH of 6.22 cm⁻¹ allowing for blanks and dilutions of measurement and deproteinising. The measurement was made against air but blanks were also run.

Standard solutions of succinate were used to check assay reagents periodically. Recoveries were >80 per cent within the period of assay used (generally 30 minutes). In assaying succinate in incubations, initial medium and media assayed after mitochondrial incubations were run together and progress followed on the chart recorder.

17 Definition of enzyme activity

1 Unit of enzyme activity is defined as the amount required to convert 1 μmol of substrate to products in 1min at 30°C.

18 Expression of results and statistical analysis

Data are expressed as means \pm SEM together with the number of assays or the number of experiments (mitochondrial preparations) given in parentheses. The results of identical experiments with different preparations were combined in one of two ways. If the means for control values did not differ significantly then data in like groups were pooled and SEM calculated directly. If control values differed significantly then data in experimental groups were combined as ratios of [experimental]/[control] and SEM of ratios calculated. The significance of differences between means was established by t-test using variance ratios to test for the significance of differences in variance between groups.

RESULTS

19 Control experiments.

Reactivation of PDH complex during pre-incubation of freshly prepared mitochondria

In order to study the specific effects of exogenous substrates added to incubation media on PDH kinase activity it was essential to remove endogenous substrate(s) from freshly prepared mitochondria and to effect full conversion of inactive (phospho) PDH complex into the active (dephospho) form. This has been achieved routinely by preincubating mitochondria in the absence of respiratory substrate as described in 8 (Incubation of rat heart mitochondria).

The efficacy of this procedure was confirmed by measuring the time course of activation of PDH complex during pre-incubation in three separate experiments (*i.e.* three mitochondrial preparations) and the experimental conditions used and the results are shown in Fig. 3.1. As can be seen from the figure PDH complex was fully reactivated within the 10min pre-incubation period. This is in good agreement with other published data from this laboratory (*e.g.* Kerbey *et al.*, 1976). The specific activity of heart mitochondrial PDH complex activity averaged 100-mU/mg-mitochondrial protein \pm 5.2 (35) and was comparable to that seen in other studies from this laboratory (*e.g.* Hutson & Randle, 1978),

CCCP-incubation of mitochondria Assay of PDH kinase requires that PDH complex be converted into the fully active (dephosphorylated) form. In freshly prepared mitochondria which are largely depleted of respiratory substrates this can be achieved by 5-10min of incubation in KCl medium (see preceding section). In mitochondria that have been rapidly isolated from media containing respiratory substrates it is to be expected that the quantity of respiratory substrate associated with mitochondria will be much greater. It was therefore necessary to speed the process of substrate depletion and associated reactivation of PDH complex by adding an uncoupler of respiratory chain phosphorylation (CCCP). To confirm that 30min of incubation sufficed to effect full re-activation of PDH complex, activity was measured during the course of the subsequent incubation with 10 μ M-CCCP in mitochondria that had been incubated with palmitoyl carnitine. These results are shown in Fig. 3.2. As can be seen from the figure

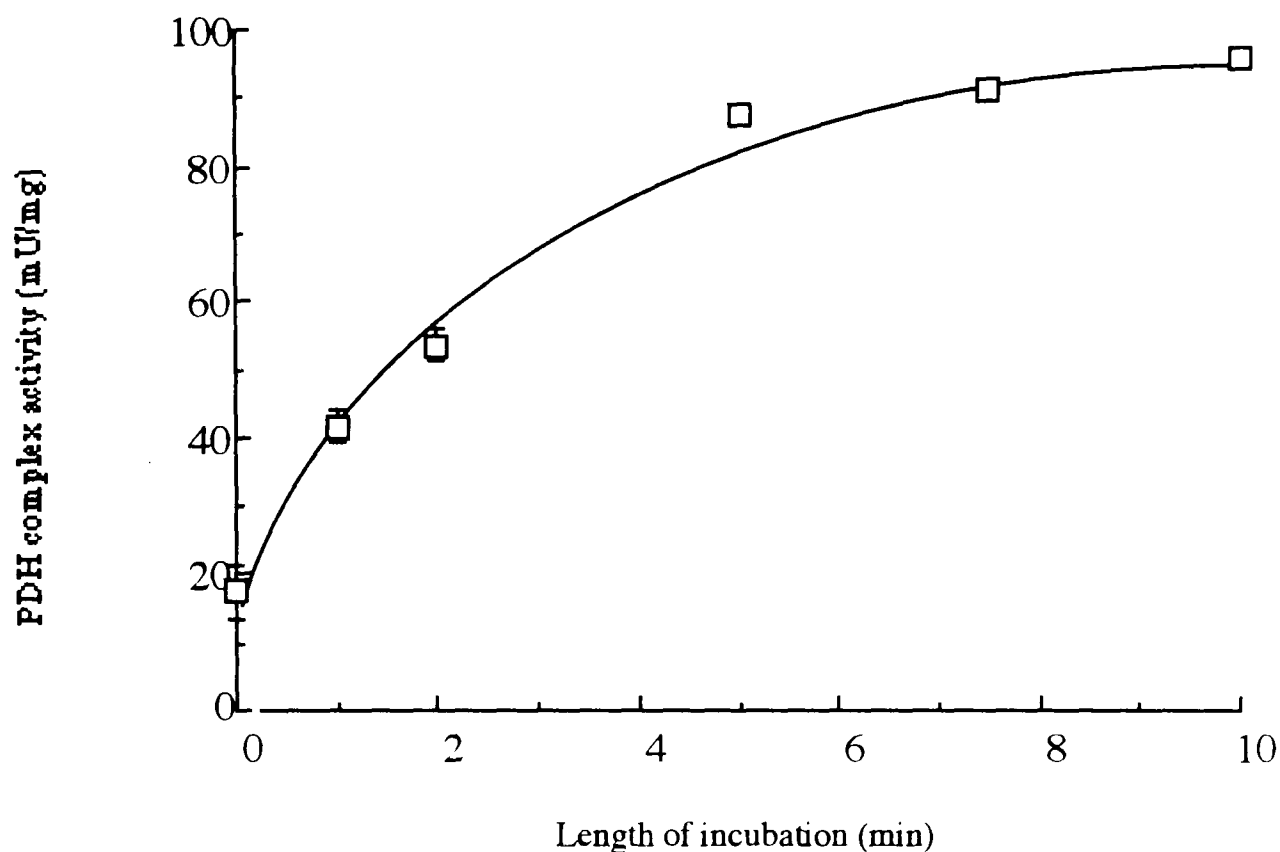
Figure 3.1 Activation of PDH complex during pre-incubation of mitochondria

Mitochondria were incubated in KCl incubation buffer (120mM-KCl/ 20mM-Tris/ 5mM-EGTA/ 5mM-KH₂PO₄ at pH 7.4) at a concentration (10mg-protein/ml) expected to yield approx. 1unit/ml PDH complex. Sample volumes (0.1ml) of incubation mix equivalent to approx. 1mg protein were pipetted into eppendorf tubes, centrifuged (13 000g for 30s at room temperature), the supernatant aspirated (hypodermic needle attached to a vacuum water pump), and the pellet immediately frozen in liquid nitrogen. Extracts were prepared by resuspension (aspiration/ejection, Hamilton syringe) in extraction buffer (50mM-KH₂PO₄/ 10mM-EGTA/ 2mM-DTT/ 1mM-MgCl₂/ 0.5mM-TLCK/ 1mM-benzamidine/ 10 μ M-leupeptin, at pH 7.0, at room temperature), and then frozen and thawed twice more (liquid nitrogen/30°C water bath). Samples were assayed for PDH complex activity and the protein concentration measured (Bradford, 1976). The specific activity of PDH complex was calculated and expressed as mU PDH complex/mg mitochondrial protein. Data are means \pm SEM for 3 experiments (*i.e.* a single incubation of three individual mitochondrial preparations)

Figure 3.2 Time course of activation of PDH complex during incubation with CCCP, of mitochondria previously incubated with palmitoyl carnitine

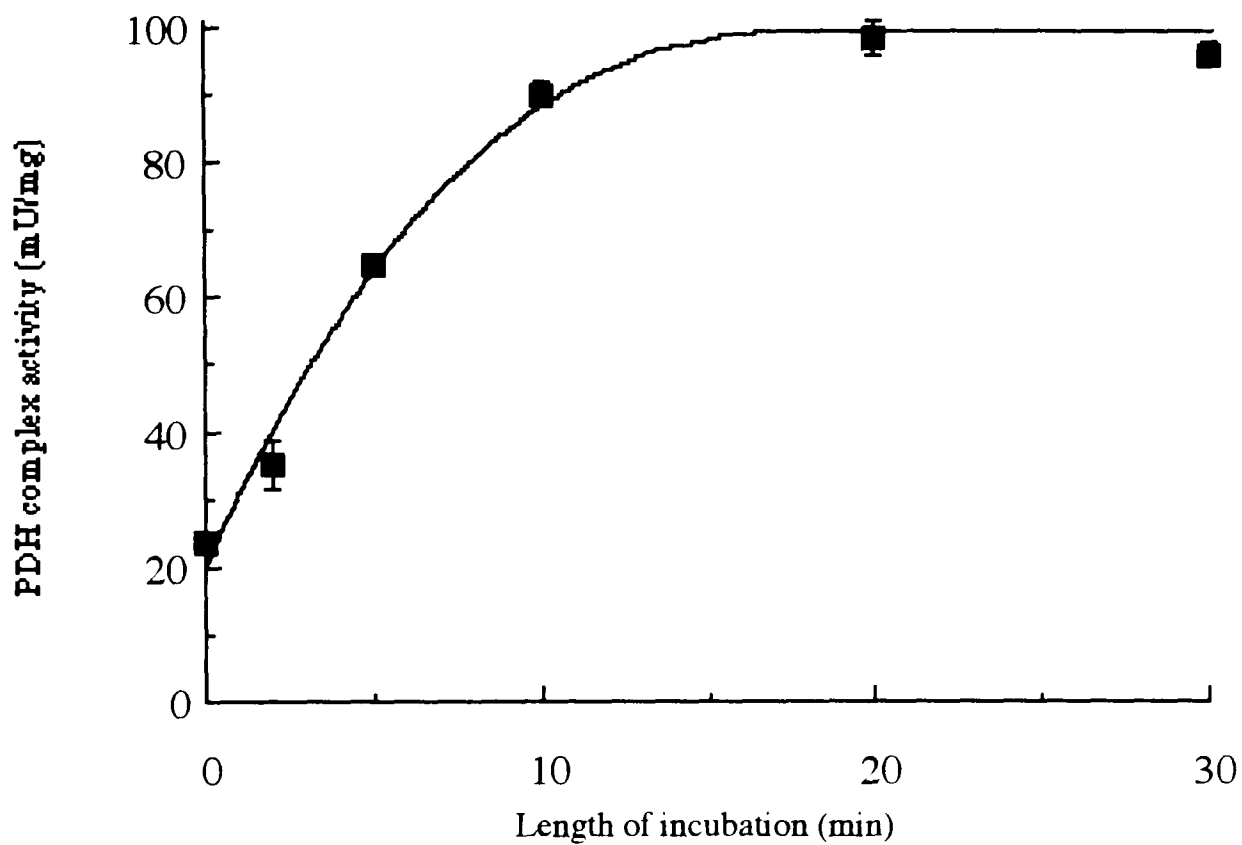

Mitochondria (200mU-PDH complex/ml) were incubated for 30min at 30°C in KCl medium (120mM-KCl/ 20mM-Tris/ 5mM-EGTA/ 5mM-KH₂PO₄ at pH 7.4) containing 50μM-palmitoyl carnitine, 0.5mM-L-malate and 0.1%-BSA (FFA-free), and swirled every 5min. A second addition of palmitoyl carnitine (50nmol/ml) was made after 30min. Samples were then centrifuged (MSE 18; 10 000g, 7-8min at 4°C) mitochondria resuspended and incubated in KCl medium containing 10μM-CCCP (200mU-PDH complex/ml) for 30min at 30°C, and re-aerated by gentle swirling at 5min intervals. At time intervals shown in the Fig. 0.5ml samples were added to eppendorf tubes containing 1mgBSA (final concentration 0.2%). BSA binds CCCP thus terminating its effect. Eppendorf tubes were centrifuged (eppendorf centrifuge; 13 000g for 30s at room temperature), supernatants were aspirated (hypodermic needle, vacuum) and discarded and pellets frozen in liquid nitrogen. Pellets were thawed and resuspended at room temperature in 100 μl extraction buffer (50mM-KH₂PO₄/ 10mM-EGTA/ 2mM-DTT/ 1mM-MgCl₂/ 0.5mM-TLCK/ 1mM-benzamidine/ 10μM-leupeptin at pH 7.0) and then frozen and thawed x2 and assayed for PDH complex activity. Data are means ±SEMs for three experiments.

reactivation was maximal by 20min and the activity of PDH complex attained the expected value (approx. 100mU/mg) within the 30min incubation period (*i.e.* reactivation was apparently complete).

Time courses for PDH reactivation with CCCP, following incubations with succinate; acetyl carnitine/malate; pyruvate malate; α -ketoglutarate/malate; and α -ketoisocaproate/malate were not investigated formally. However, PDH complex activities of mitochondria (munits/mg protein) following 30min of CCCP incubation were consistent with full reactivation (*i.e.* they were comparable to activities in mitochondria not incubated with these respiratory substrates - results not shown).

Rat heart mitochondrial PDH kinase activities; no substrate incubations The ratio of PDH kinase activities measured in extracts from mitochondria incubated for 0 and 60min in the absence of respiratory substrates (followed by a further 30min in 10 μ M-CCCP) was 1.07 ± 0.07 (60min/0min; mean \pm SEM for 7 preparations of mitochondria; data from Table 3.2). Thus mitochondrial PDH kinase activity was stable for at least 60min in no substrate incubations.

20 The effect of palmitoyl-L-carnitine/L-malate on the activity of PDH kinase in rat heart mitochondria, *in vitro*.

Protocol In these experiments heart mitochondria were depleted of endogenous respiratory substrates by no substrate incubation as described in section 8. They were then incubated at 38°C in KCl medium containing palmitoyl carnitine, malate and mitochondria (final concentrations; 50 μ M, 0.5mM and 200mU-PDH complex/ml respectively), for 5, 15, 30 and 60min. In 60min incubations a further addition of palmitoyl carnitine (to 50nmol/ml) was made at 30min to restore concentration (see later). At 60min incubates were centrifuged and pellets resuspended in KCl medium containing 10 μ M-CCCP (see section 9 Activation of PDH complex). Supernatants were collected and carnitine concentration measured (see section 14 Assay of L-carnitine). Pellets were resuspended plus 100 μ l extraction buffer (50mM-KH₂PO₄/10mM-EGTA/2mM-DTT/1mM-MgCl₂/0.5mM-TLCK/1mM-benzamidine/10 μ M-leupeptin at pH 7.0 at room temperature) containing oligomycin B (31 μ g/ml), rapidly frozen/thawed in liquid

Table 3.2 PDH kinase activity; heart mitochondria fed rats; palmitoyl carnitine

PDH kinase activity: (min ⁻¹ mean ± SEM); mitochondria incubated with :-					
NS (t=0)	NS (t=60)	PC (t=5)	PC(t=30)	PC(t=60)	$\frac{PC(t=60)}{NS(t=60)}$
0.35(1)				0.99 ± 0.10 (5)	
0.17 ± 0.05 (3)		0.50 ± 0.14 (3)*	0.50 ± 0.02 (3)	0.46 ± 0.04 (6)	2.71±0.56
0.20 ± 0.02 (3)		0.50 ± 0.06 (3)		0.49 ± 0.01 (3)	2.45±0.22
0.20 ± 0.02 (3)				0.51 ± 0.06 (5)	2.55±0.33
0.32 ± 0.05 (3)		0.30 ± 0.03 (4)		0.70 ± 0.04 (4)	2.19±0.29
0.46 ± 0.12 (4)				1.20 ± 0.12 (4)	2.61±0.59†
0.37 ± 0.04 (3)				0.62 ± 0.04 (4)	1.68±0.17
0.47 ± 0.10 (5)				1.22 ± 0.01 (5)	2.60±0.05
0.45 ± 0.02 (5)				0.91 ± 0.02 (5)	2.02±0.08
0.21 ± 0.01 (5)				0.88 ± 0.10 (5)*	4.20±0.41
0.21 ± 0.01 (5)				0.95 ± 0.05 (5)	4.52±0.25
0.14 ± 0.02 (5)				0.76 ± 0.02 (5)	5.43±0.62
0.11 ± 0.01 (5)				0.42 ± 0.02 (5)	3.82±0.31
0.21 ± 0.01 (5)				0.44 ± 0.03 (5)*	2.09±0.08
0.34 ± 0.04 (5)	0.41 ± 0.04 (4)†			1.19 ± 0.01 (2)‡	2.90±0.28
0.16 ± 0.04 (3)	0.16 ± 0.02 (3)†			0.26 ± 0.03 (3)*	1.63±0.24*
0.21 ± 0.01 (1)	0.26 ± 0.01 (3)‡			0.43 ± 0.03 (3)*	1.65±0.16
0.18 ± 0.02 (4)	0.20 ± 0.01 (3)†			0.19 ± 0.01 (5)*	0.95±0.06*
	0.39 ± 0.01 (3)				
0.20 ± 0.01 (3)	0.25 ± 0.01 (3)†				
0.34 ± 0.01 (5)	0.38 ± 0.04 (5)†			0.94 ± 0.01 (5)	2.47±0.21
0.28 ± 0.01 (5)	0.16 ± 0.03 (4)†	0.69 ± 0.08 (5)	0.45 ± 0.02 (4)	0.76 ± 0.03 (4)	4.95±0.74
	0.29 ± 0.02 (5)			0.65 ± 0.05 (4)	2.24±0.19
	0.26 ± 0.01 (3)			0.48 ± 0.01 (3)	1.85±0.07
NS₆₀ - NS₀	0.016 ± 0.024		Overall Mean ± SEM		2.89±0.12

NS, no substrate control; PC, 50μM-palmitoyl carnitine t= min of incubation. For columns 1-5:-

*P>0.05 vs no substrate control; for other differences P<0.02; ‡ mean ± 0.5 difference between means. (less than three observations in group) †P>0.05 vs NS (t=0); for other differences P<0.02 For column 6 * P>0.05; † P<0.05 for differences from unity; for other differences P<0.02

Mitochondria were prepared from rat hearts and preincubated for 10min at 30°C in KCl medium with aeration by swirling at 20s intervals to effect conversion of inactive (phosphorylated) PDH complex into the active (dephosphorylated) form. Mitochondria were then incubated ± PC/0.5mM-L-malate/0.1%-BSA for the time shown, sedimented and then resuspended in KCl medium containing CCCP, incubated for 30min to remove residual respiratory substrate, sedimented, extracted by freeze thawing and extracts assayed for PDH kinase. Each line in the table contains results of experiments with a single mitochondrial preparation. For further details see Experimental section.

N₂/ water bath at 30°C (x3), and assayed for PDH kinase (see section 11 Assay of PDH kinase activity).

Palmitoyl carnitine disappearance during incubation Degradation of palmitoyl carnitine during mitochondrial incubation was followed by monitoring the appearance of L-carnitine in the incubation medium (enzymatic assay -see section 14). A standard curve validating the carnitine assay is shown in Fig. 3.3; the slope was unity and the intercept on the x axis (0.41) was not significant. The rate of degradation of palmitoyl carnitine (*i.e.* appearance of carnitine) during mitochondrial incubation is shown in Fig. 3.4. The rate of appearance of carnitine was linear with a half time of approximately 15min, and complete by 30min.

Palmitoyl carnitine; effect on PDH kinase activity. PDH kinase activity in heart mitochondria of fed rats increased approximately 2.5-fold within 5min of incubation of mitochondria with palmitoyl carnitine (PC) and showed no further significant change thereafter at 30 or 60min of incubation (Fig. 3.5). Table 3.2 shows the results of experiments with twenty two individual rat heart mitochondrial preparations and these are also presented as a scatter diagram with overall means \pm SEM in Fig. 3.6. PC increased PDH kinase activity in all 22 experiments though statistical significance was not achieved in five of these mainly because of differences in variance between the two groups. Overall PC increased PDH kinase activity in heart mitochondria from fed rats by $[2.82 \pm 0.24]$ -fold (PC, t=60 vs NS, t=0) or by $[2.27 \pm 0.40]$ -fold (PC, t=60 vs NS, t=60); $P < 0.001$, $P < 0.02$ respectively for difference from unit ratio.

Starvation of rats for 48h is known to increase PDH kinase activity in heart mitochondrial extracts relative to activities in the fed (Hutson & Randle, 1978). It is known also that fatty acids increase PDH kinase activity in cardiac myocytes from fed rats in tissue culture after (Marchington *et al.*, 1990). The (starved - fed) difference in PDH kinase activity is retained after 24h of culture and fatty acids failed to increase PDH kinase activity in myocytes from starved rats in culture (Marchington *et al.*, 1990). It was important therefore to ascertain whether the short term effect of palmitoyl carnitine on PDH kinase activity in heart mitochondria from fed rats described here was also demonstrable in heart mitochondria from 48h starved rats.

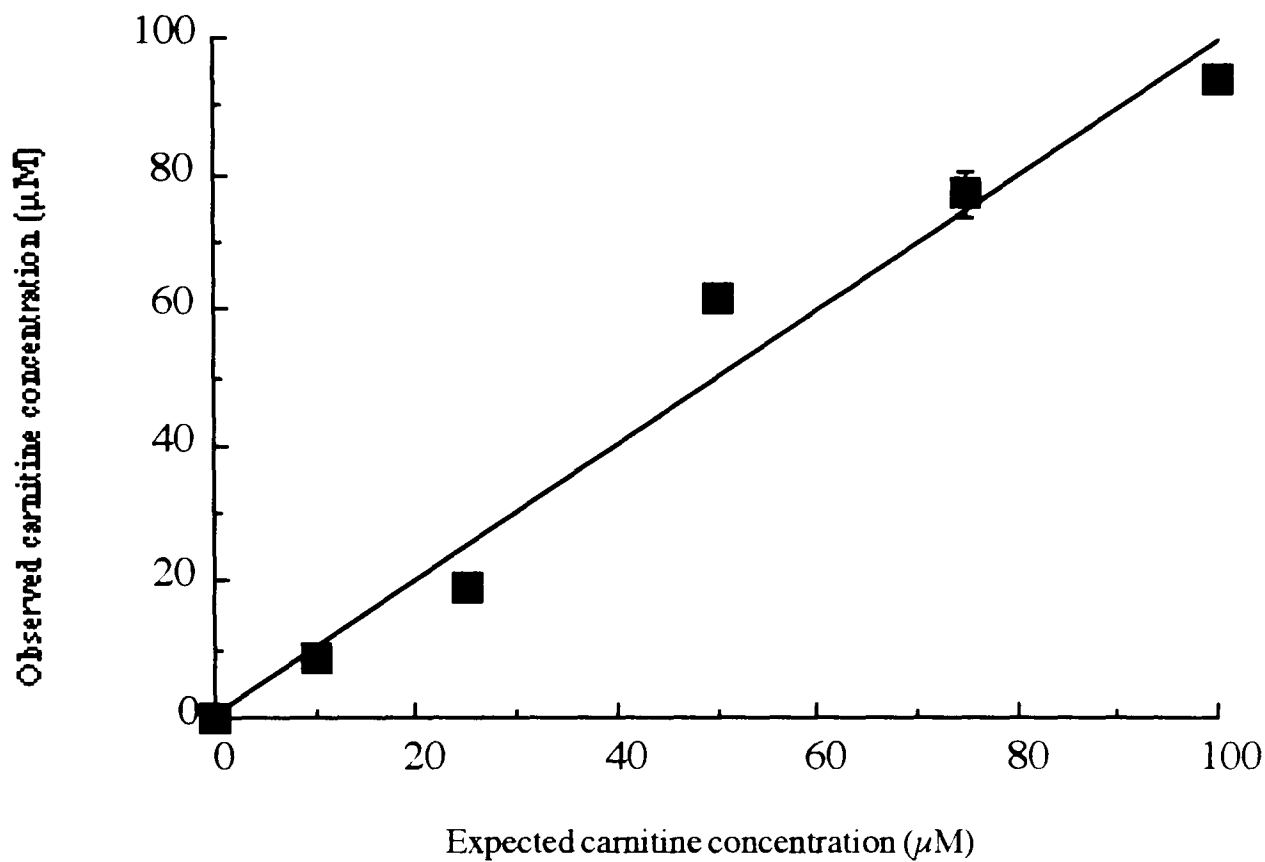
Figure 3.3 Validation of L-carnitine assay (recovery of added carnitine)

Standard L-carnitine solution was put through the procedure for mitochondrial incubation media, *i.e.* deproteinised with PCA (sections 12 and 14), ether extracted to remove palmitate and carnitine concentration measured by enzymatic assay with carnitine acetyl transferase (for details see section 14). Data represent means \pm SEM for 3 assays. Linear regression analysis gave slope (mean \pm SEM of 0.993 ± 0.083 ($r=0.986$; $P>0.05$ for difference from unity).

Figure 3.4 Time course for appearance of carnitine in mitochondrial incubation media containing palmitoyl carnitine

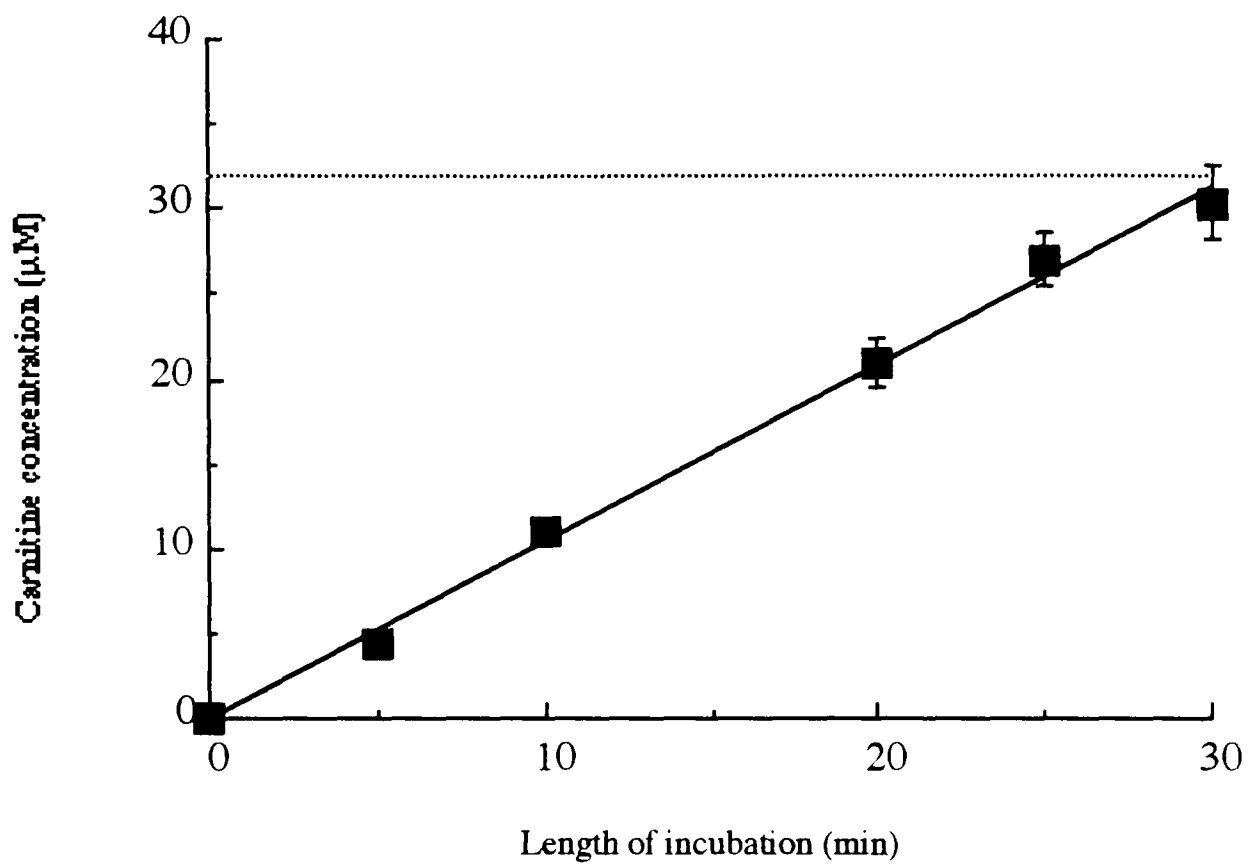

Rat heart mitochondria were incubated with palmitoyl-carnitine. By weight palmitoyl-carnitine concentration was $50\mu\text{M}$ and by assay following alkaline hydrolysis it was $32\mu\text{M}$ (represented on the figure as a horizontal line). Samples of incubation medium were taken at the times shown, centrifuged and the supernatant assayed in triplicate for carnitine following deproteinisation. Points are means \pm SEM.

Figure 3.5 PDH kinase activity in extracts of rat heart mitochondria: effects of incubation of mitochondria with palmitoyl-L-carnitine: time course

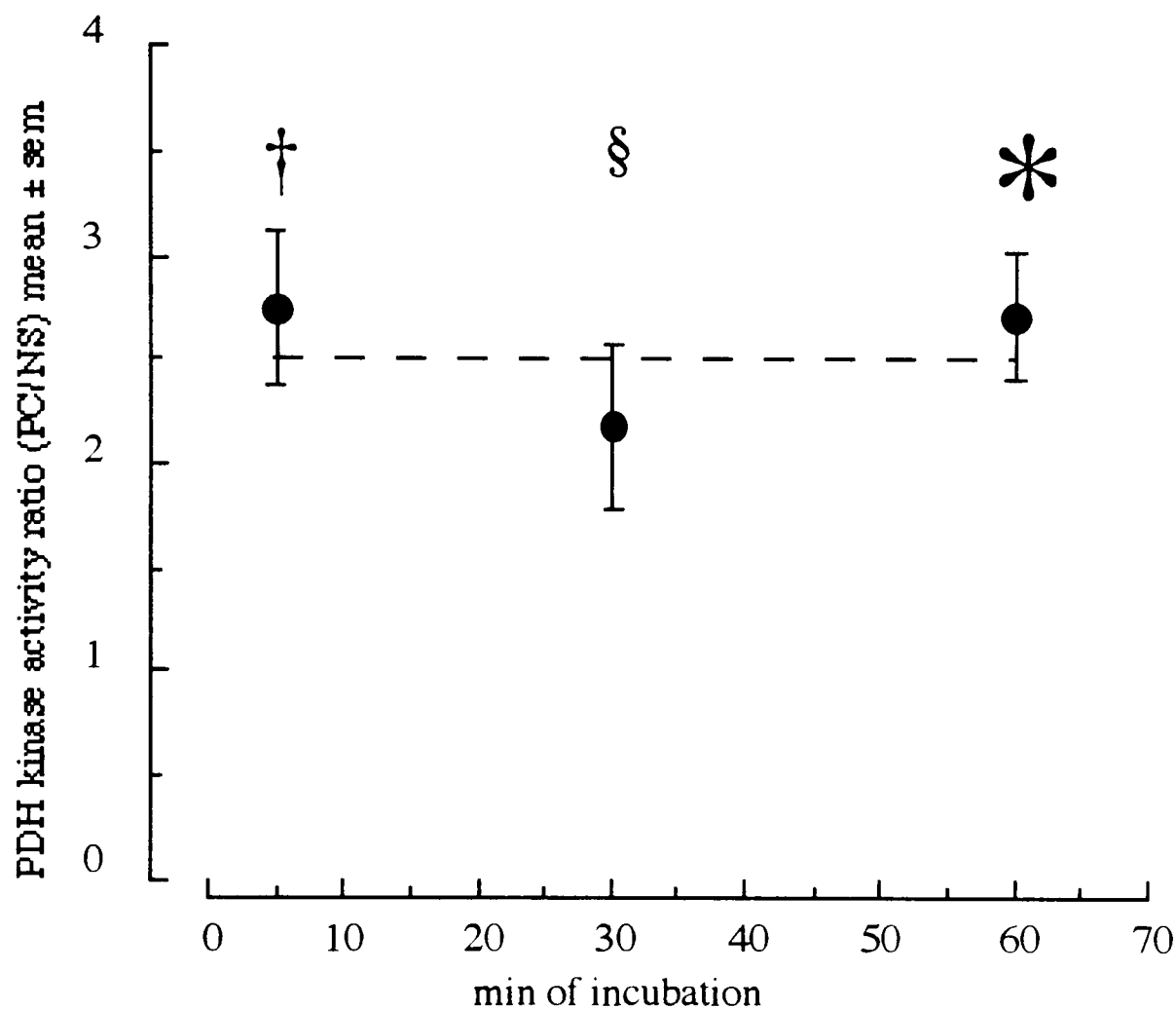

* $P < 0.001$, † $P < 0.01$, § $P < 0.05$ for difference from 1

Abbreviations: PC, palmitoyl carnitine; NS, no substrate. Results are means of experiments with two mitochondrial preparations and 3 to 6 assay runs with each preparation.

Heart mitochondria from fed normal rats were preincubated in KCl medium for 10min at 30°C to remove endogenous respiratory substrates. Aliquots were then diluted to 200munit-PDH complex/ml and incubated at 30°C for 5, 30 or 60min in KCl medium with 50μM-palmitoyl carnitine/0.5mM-L-malate (with further addition at 30min of palmitoyl carnitine to 50μM in the 60min incubation). At the end of incubation mitochondria were separated by centrifugation, resuspended in KCl medium containing 10μM-CCCP, incubated for 30min at 30°C, sedimented, extracted by freeze thawing, and extracts assayed for PDH kinase by the rate of ATP dependent inactivation. The no substrate controls were mitochondria taken at the end of preincubation and incubated with CCCP as above (other control experiments had shown that no substrate incubations for up to 60min were without effect on PDH kinase activity). For further details see legend to Fig 3.1 or experimental sections.

Figure 3.6 PDH kinase activities; extracts of individual rat heart mitochondrial preparations incubated \pm palmitoyl carnitine

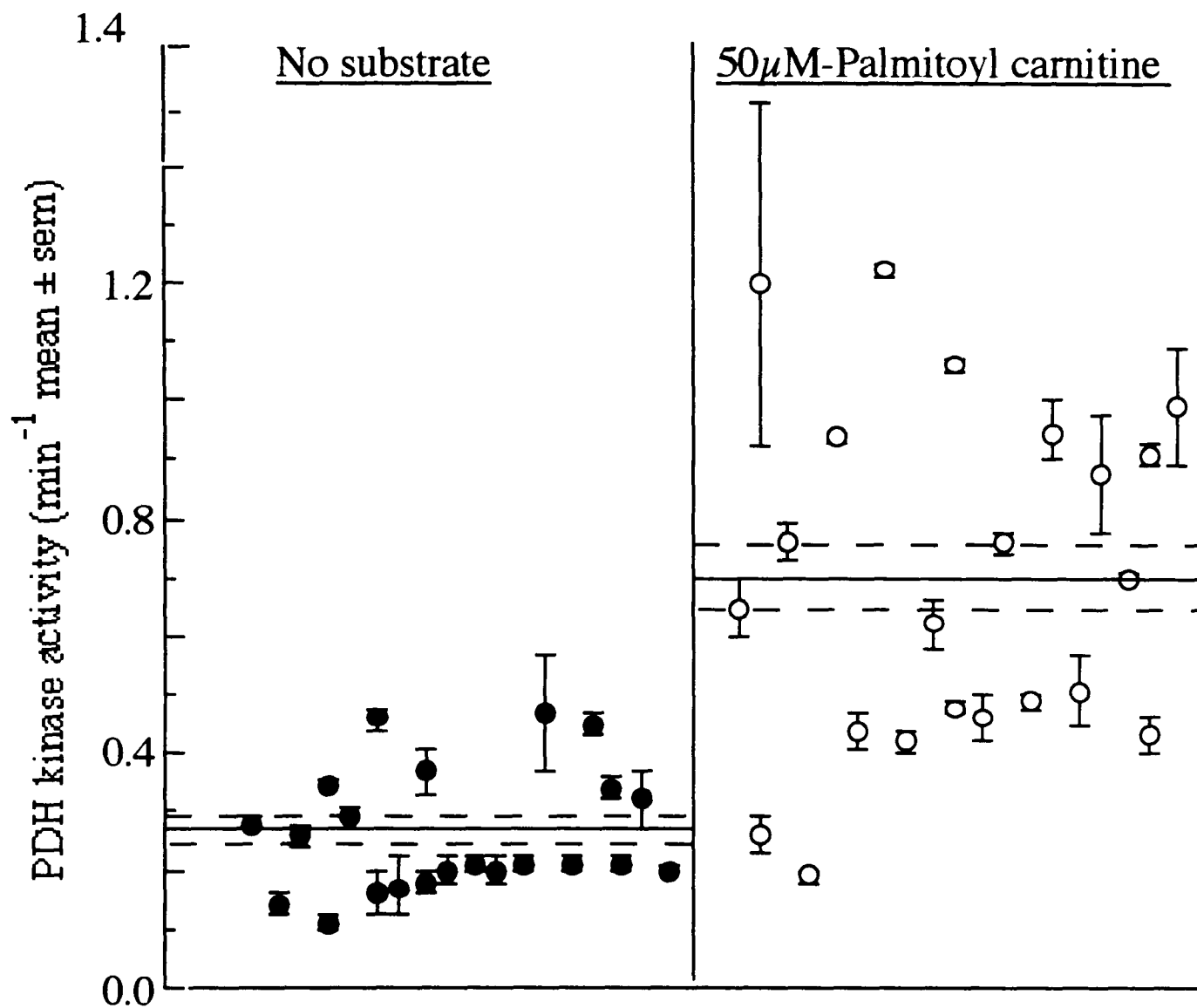

Scattergram of data from corresponding values from columns 1 and 5 in Table 3.2 except that the last two values in column 2 accompany the last two values in column 5.

Incubation of heart mitochondria from starved or fed rats with palmitoyl carnitine (PC) resulted in a significant increase in PDH kinase activity above no substrate controls in both groups ($P < 0.001$, starved; $P < 0.05$, fed). The ratios of PDH kinase activities in extracts of mitochondria incubated \pm palmitoyl carnitine (+PC/-PC) for fed and starved rats were not significantly different (see Fig. 3.7).

21 The effects of acetyl carnitine/L-malate, α -ketoglutarate/L-malate, α -ketoisocaproate/L-malate, pyruvate/L-malate and succinate on the activity of PDH kinase in rat heart mitochondria *in vitro*.

The results of experiments given in the preceding section showed that incubation of rat heart mitochondria with palmitoyl carnitine/L-malate led to an increase in PDH kinase activity in extracts prepared from mitochondria depleted of respiratory substrates by washing followed by 30min of incubation with CCCP. Mitochondria form palmitoyl-CoA via carnitine acyl transferase and acetyl-CoA by β -oxidation. The experiments to be described in this section show the results of comparable studies with respiratory substrates which form other acyl-CoA compounds. These comprised succinate which can give rise to succinyl-CoA by succinate thiokinase; α -ketoglutarate which can give rise to succinyl-CoA by α -ketoglutarate dehydrogenase; α -ketoisocaproate which can give rise to 3-methylbutyryl-CoA (through the branched chain ketoacid dehydrogenase complex) and by further metabolism succinyl-CoA and acetyl-CoA; acetyl carnitine which can give rise to acetyl-CoA via carnitine acetyl transferase; and pyruvate which can form acetyl-CoA via the pyruvate dehydrogenase complex. The overall results are summarised in Fig. 3.3, Table 3.2, and ratios in Table 3.3, and results pertaining to individual substrates in other Figures.

Experiments with succinate Fig. 3.8 shows progress curves for the disappearance of succinate during incubation with 5mM-succinate of heart mitochondria from fed and 48h starved. Half times were approximately 30min for mitochondria from starved rats and 45min for mitochondria from fed rats. Fig. 3.9 shows a time course for the effect of succinate on PDH kinase activity in single preparations of heart mitochondria from fed and 48h starved rats. With

Figure 3.7 PDH kinase activities: heart mitochondria from fed and 48h starved rats incubated \pm palmitoyl carnitine

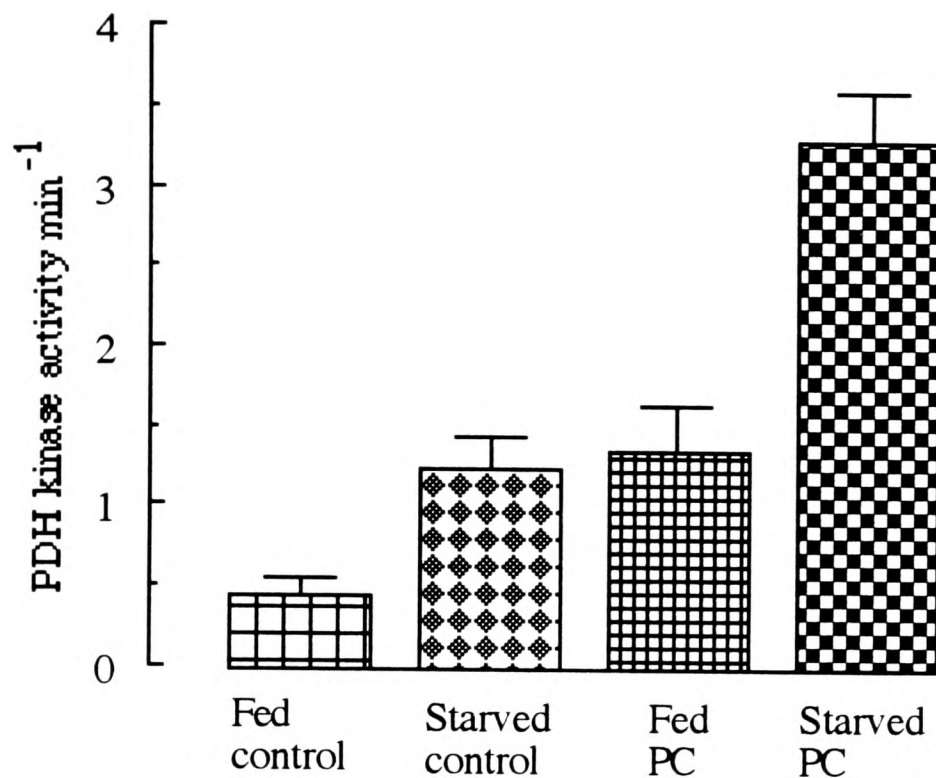

Heart mitochondria from fed and 48 h starved rats were incubated in the presence of $50\mu\text{M}$ -palmitoyl carnitine for 60min, sedimented, resuspended in KCl medium containing $10\mu\text{M}$ -CCCP, incubated 30min at 30°C to reactivate PDH complex, centrifuged, resuspended, extracted and PDH kinase activity measured in the extracts. Mitochondrial incubations were PC = palmitoyl carnitine, control = no substrate. Data represent means \pm SEM for 8 (PC fed) or 9 (remaining groups) assays on three mitochondrial preparations. $P < 0.001$ for PC starved versus PC fed; $P < 0.01$ for NS starved versus NS fed; $P < 0.05$ for PC fed versus NS fed. Ratios were:- PC starved/NS starved, 2.62 ± 0.35 ; PC fed/NS fed, 3.30 ± 0.85 ($P > 0.05$ for difference).

Table 3.3 PDH kinase activities; heart mitochondria, fed rats; effects of palmitoyl carnitine, acetyl carnitine, pyruvate, α -ketoglutarate, α -ketoisocaproate (all + L-malate), and succinate.

PC, 50 μ M-palmitoyl-L-carnitine; NS, no substrate; MA, 0.5mM-L-malate; SU, 5mM-succinate; AC, 5mM-DL-acetyl carnitine; PY, 75 μ M-pyruvate; KG, 5mM- α -ketoglutarate; KI, 5mM- α -ketoisocaproate

<u>PC/MA(t=60)</u> NS (t=0)	<u>PC/MA(t=60)</u> NS (t=60)	<u>NS (t=60)</u> NS (t=0)	<u>PC/MA (t=5)</u> NS (t=0)	<u>PC/MA(t=30)</u> NS (t=0)
2.89 \pm 0.12*(21)	2.27 \pm 0.40†(8)	1.07 \pm 0.07(7)	2.20 \pm 0.43§(4)	2.30 \pm 0.69(2)
<u>SU (t=60)</u> NS (t=0 or 60)	<u>AC/MA (t=60)</u> NS (t=0 or 60)	<u>PY/MA (t=60)</u> NS (t=0 or 60)	<u>KG/MA (t=15)</u> NS (t=0)	<u>KI/MA (t=15)</u> NS (t=0)
1.61 \pm 0.16*(13)	1.24 \pm 0.11#(6)	1.13 \pm 0.13(6)	1.87 \pm 0.20≠(4)	1.76 \pm 0.19≠(4)

Mitochondria were prepared from rat hearts and pre-incubated for 10min at 30°C in KCl medium with aeration by swirling at 20s intervals to effect conversion of inactive (phosphorylated) PDH complex into the active (dephosphorylated) form. Mitochondria were then incubated \pm additions for the time shown, sedimented, resuspended in KCl medium containing CCCP, incubated for 30min to remove residual respiratory substrate, sedimented, extracted by freeze thawing and extracts assayed for PDH kinase. For further details see Experimental section. In pyruvate/malate incubations pyruvate concentration was maintained by addition of 5 μ l of 5mM-pyruvate (25nmol)/ml of incubate (the maintained concentrations by direct assay were 73 μ M and 74.6 μ M at 15 and 30min respectively).

*P<0.001; †P<0.02>0.01; §P <0.05>0.02; #P = 0.052; for difference from 1.00; other differences P>0.05; ≠ one mitochondrial preparation, P<0.02 for (pyruvate - no substrate)

Figure 3.8 Medium succinate concentration during incubation of rat heart mitochondria.

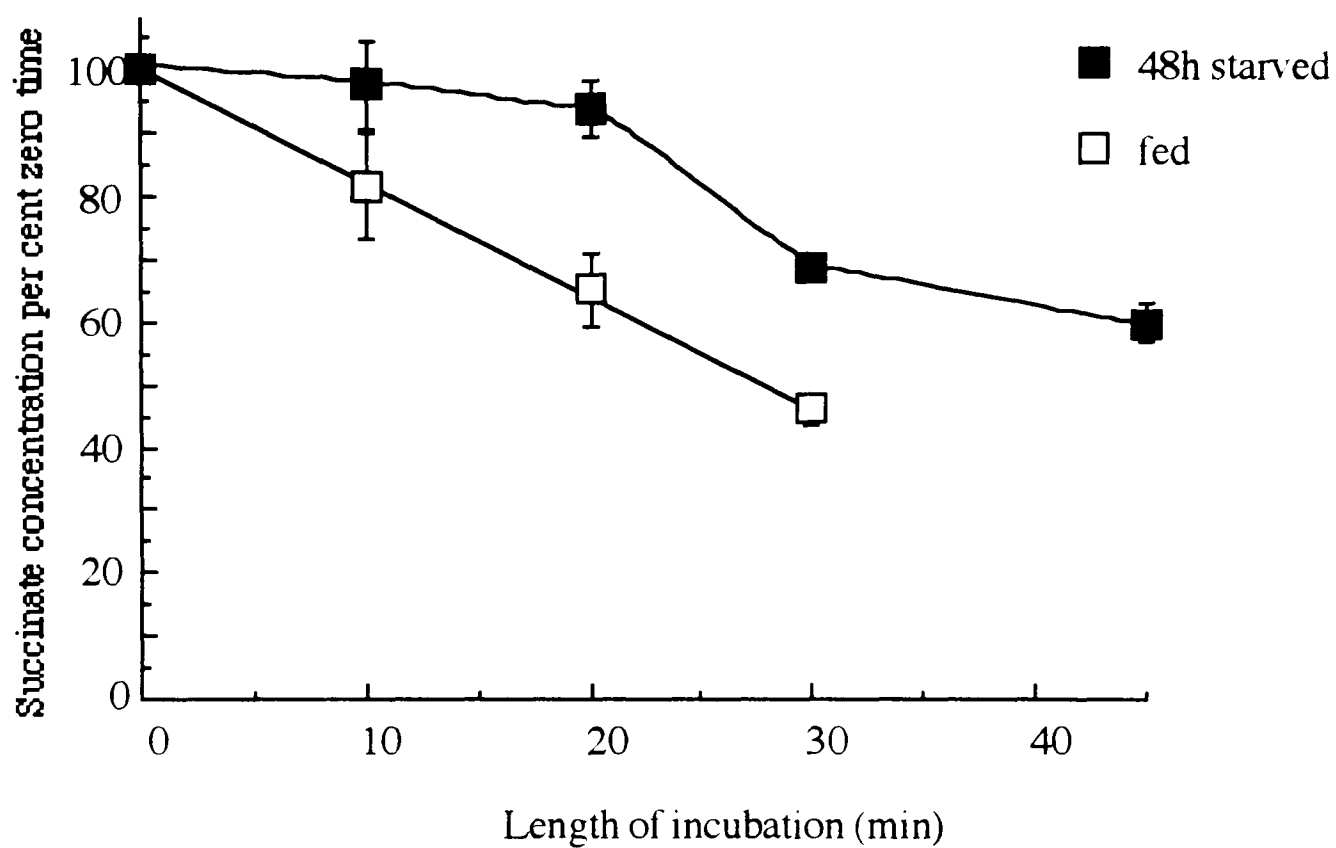

Heart mitochondria were prepared from fed and 48h starved rats, and preincubated for 10min at 30°C in KCl medium with aeration by swirling at 20s intervals to effect conversion of inactive (phosphorylated) PDH complex into the active (dephosphorylated) form. Mitochondria were then incubated with 5mM-succinate for up to 45min. Samples were taken periodically, centrifuged and the supernatants deproteinised before assayed for succinate. Data represent means \pm SEM for two experiments with starved and 5 fed experiments with fed rats.

Figure 3.9 Time course for effect of succinate on PDH kinase activity of rat heart mitochondria

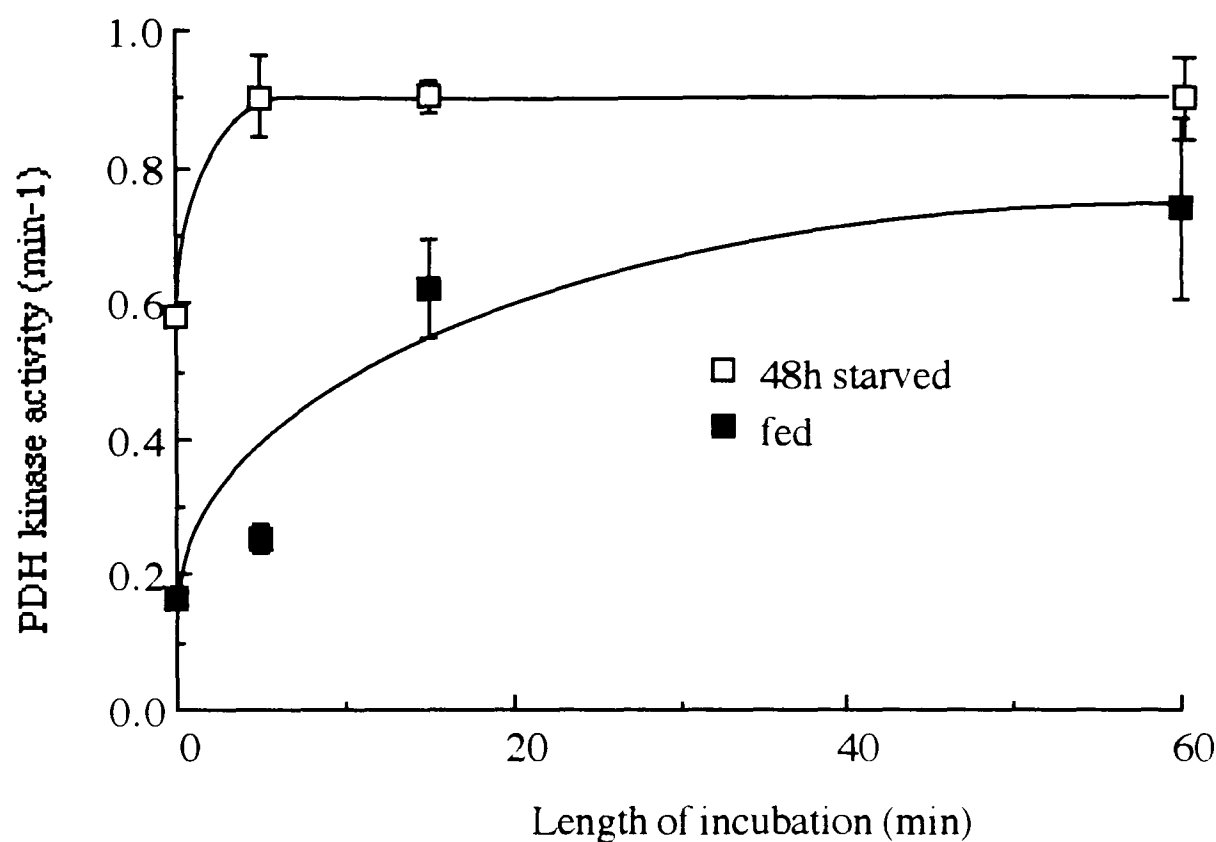

Heart mitochondria were prepared from fed and 48h starved rats and preincubated for 10min at 30°C in KCl medium with aeration by swirling at 20s intervals to effect conversion of inactive (phosphorylated) PDH complex into the active (dephosphorylated) form. Mitochondria were then incubated with 5mM-succinate for the time shown, centrifuged and then resuspended in KCl medium containing CCCP, incubated for 30min, sedimented, extracted by freeze thawing and extracts assayed for PDH kinase. For further details see text. Results are means \pm SEM for 4 assays. The difference between fed and starved at zero, 5 and 15min exposure to succinate are significant ($P < 0.001$, $P < 0.001$ and $P < 0.05$), but not at 60min ($P > 0.05$).

both mitochondrial preparations succinate increased PDH kinase activity significantly within five minutes. With mitochondria from starved rats activation was essentially complete within 5min; with mitochondria from fed rats activation was complete within 15min. The starved-fed difference was maintained throughout though it was not statistically significant at 60min. As shown in Table 3.3 the overall results with 13 mitochondrial preparations from fed rats at 60min of incubation was a 61 per cent increase in PDH kinase activity with succinate.

Experiments with α -ketoglutarate/L-malate and α -ketoisocaproate/L-malate The effect of 5mM- α -ketoglutarate/ 0.5mM-L-malate and of 5mM- α -ketoisocaproate/0.5mM-L-malate are shown in Table 3.3 and in Fig. 3.10. Both substrates increased PDH kinase activity significantly in mitochondria from fed rats (by 87% and 67% respectively) but the increases in mitochondria from starved rats were not significant.

Experiments with acetyl-DL-carnitine/L-malate As shown in Fig. 3.11 there was an approximately 25 per cent loss of L-carnitine from the medium during 60min of incubation. The effects on PDH kinase activities are shown in Fig. 3.12 and in Table 3.3. In the time course (Fig. 3.12) there were significant increases in PDH kinase activity (approximately 2-fold) at 15, 30 and 46min of incubation. In other experiments involving 60 min of incubation the effect of 0.5mM-acetyl-DL-carnitine/L-malate was smaller (24%) and not statistically significant.

Experiments with pyruvate/L-malate Pyruvate at low concentrations and in the presence of TPP is an activator of PDH kinase, at higher concentrations is an inhibitor, and in looking at its effects as a source of acetyl-CoA in mitochondria it was used it at a concentration (50-74 μ M) at which it is as effective as α -ketoglutarate/L-malate to decrease the percentage of PDHa in incubated mitochondria (Kerbey *et al.*, 1976). At a concentration of 43 μ M pyruvate was completely utilised within 2 to 3min of incubation (Fig. 3.13). When mitochondria were incubated in 50 μ M-pyruvate and repeated additions made (per ml of incubate) of 25nmol pyruvate in 5 μ l at 45s intervals and analysis at 15min and 30min of incubation showed pyruvate concentrations of 73 μ M and 74.6 μ M respectively. As shown in Fig. 3.14 and in Table 3.3 pyruvate at this concentration (and with 0.5mM-L-malate) had no significant effect on PDH kinase activity.

Figure 3.10 PDH kinase activity from mitochondria incubated with α -ketoglutarate plus L-malate or α -ketoisocaproate plus L-malate

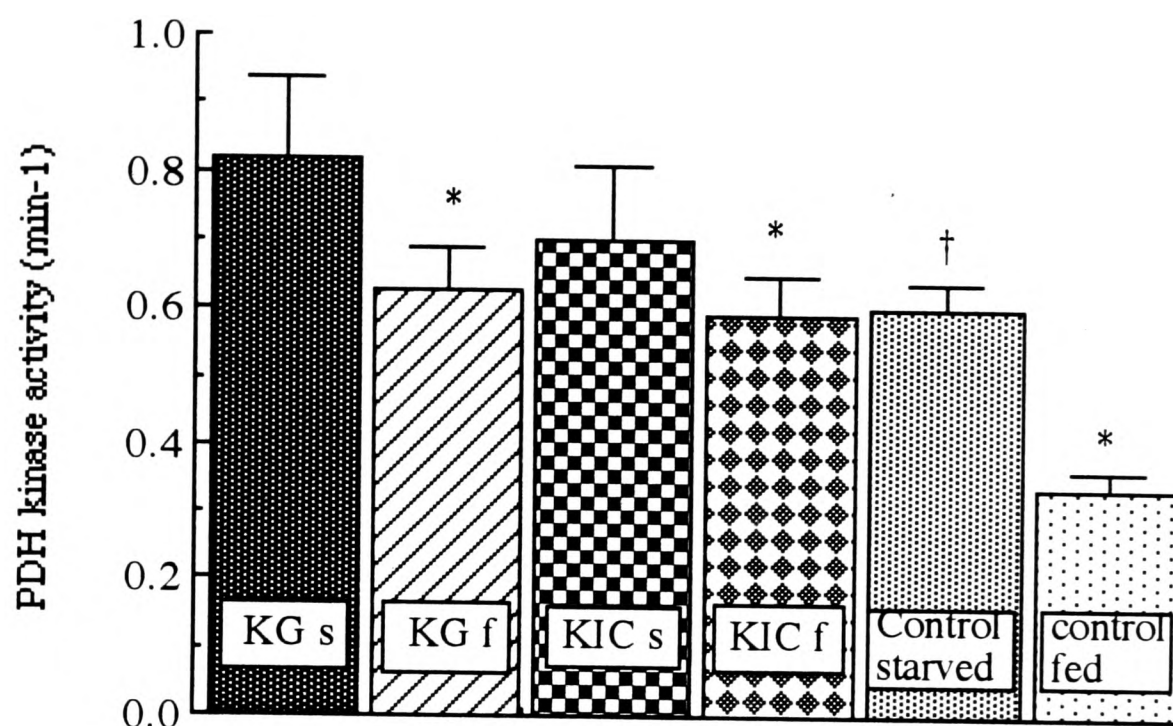

Mitochondria from hearts of fed and 48 h starved rats were incubated in medium containing 5mM- α -ketoglutarate/0.5mM-L-malate or 5mM- α -ketoisocaproate/0.5mM-L-malate for 15min. At the end of the incubation samples were centrifuged, resuspended and incubated in KCl incubation buffer with CCCP to activate PDH complex. Samples were centrifuged, resuspended, extracted and PDH kinase activity measured. For further details see text. Data represent means \pm SEM for 4 assays. KG = α -ketoglutarate, KIC = α -ketoisocaproate, NS = no substrate: s and f refers to 48 h starved and fed rats respectively. * denotes $P < 0.01$ for difference from no substrate control. † $P < 0.01$ for difference from fed control.

Figure 3.11 Time course for the disappearance of acetyl carnitine from mitochondrial incubation medium

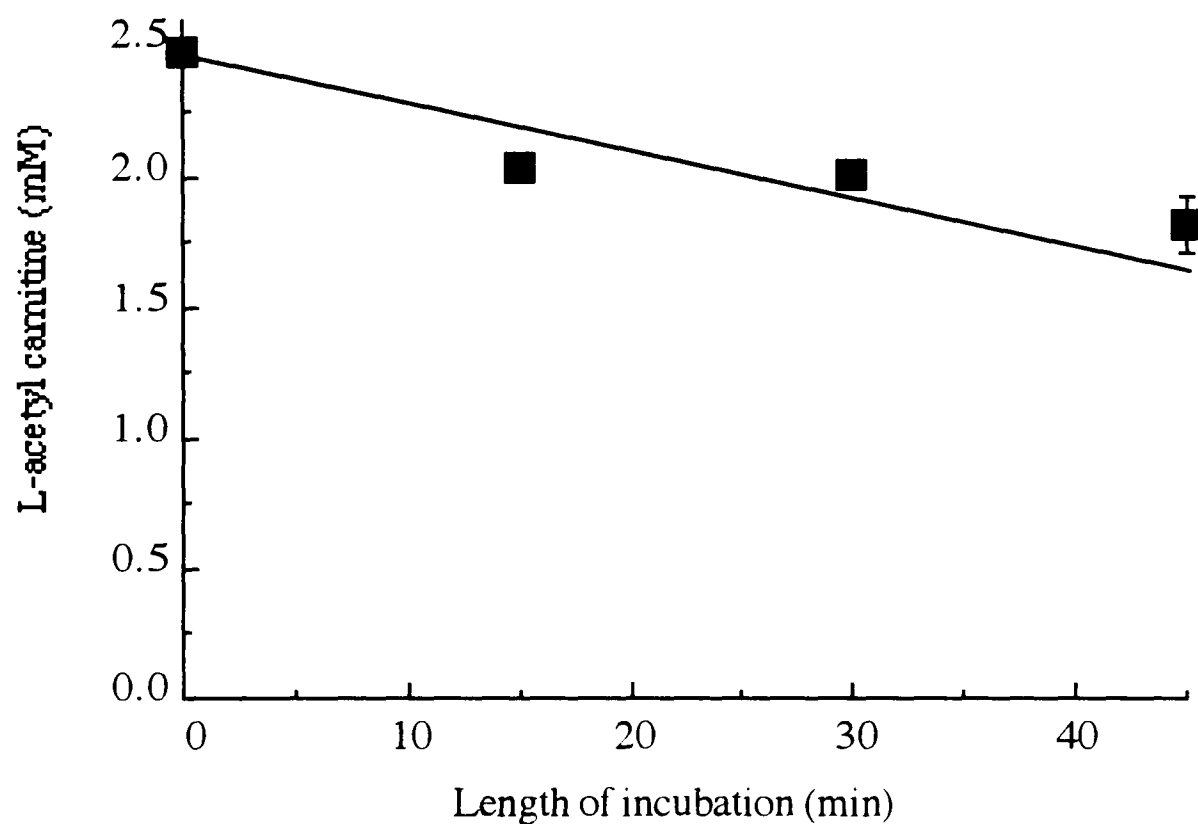

Rat heart mitochondria were pre-incubated for 10min at 30°C in KCl medium with aeration by swirling at 20s intervals to effect conversion of inactive (phosphorylated) PDH complex into the active (dephosphorylated) form. Mitochondria were then incubation media containing 2.5mM acetyl carnitine + 0.5mM-L-malate for up to 45min. Following incubation samples were centrifuged, and acetyl L-carnitine assayed in the supernatant, after deproteinisation, with CoA plus carnitine acetyl transferase and arylamine acetyl transferase. For further details see experimental. Data represent means \pm SEM for 7 assays for each time point.

Figure 3.12 Time course for PDH kinase activity of heart mitochondria incubated with acetyl-DL-carnitine + L-malate

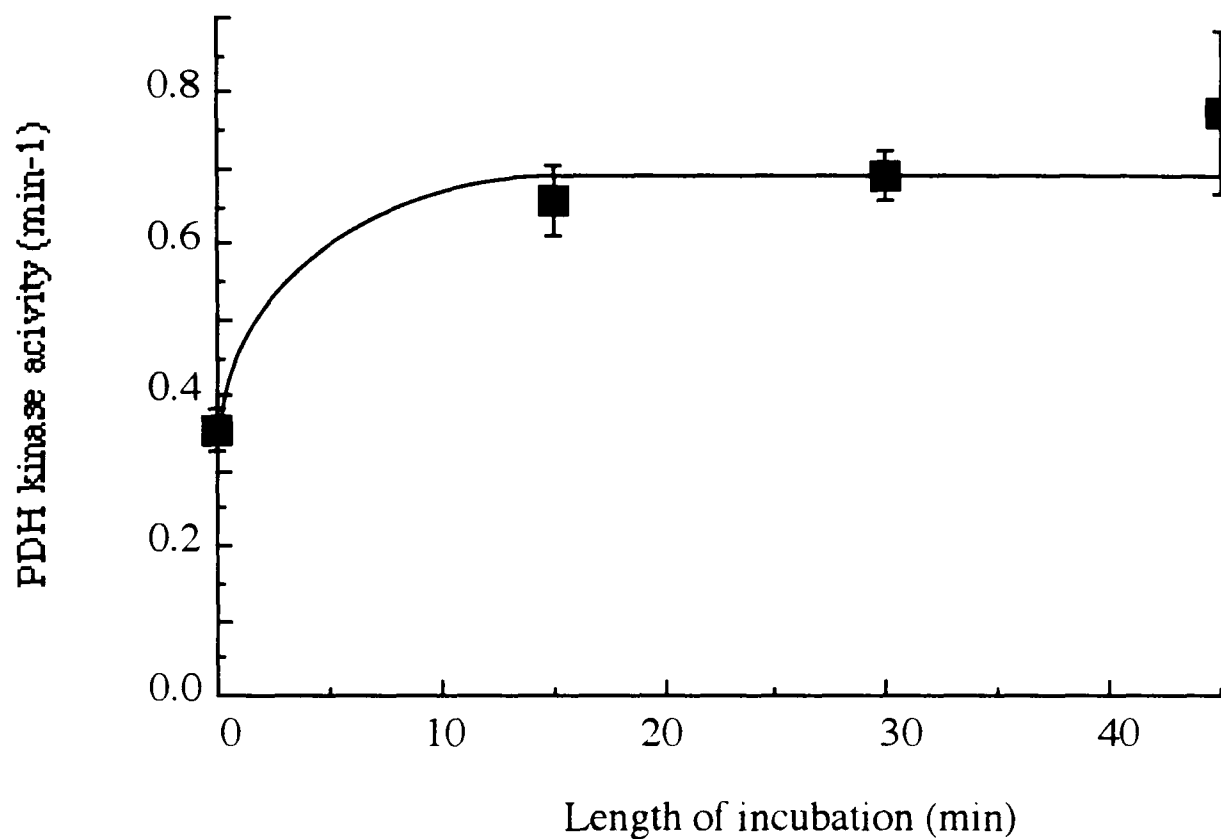

Heart mitochondria (fed rats) were pre-incubated to deplete mitochondria of endogenous substrate and effect conversion of inactive (phosphorylated) PDH complex to the active (dephosphorylated) form, in KCl incubation buffer. Mitochondria were then incubated in KCl incubation buffer containing 5mM-acetyl-DL-carnitine + 0.5mM-L-malate for up to 45min. Samples were taken at 0, 15, 30 and 45min, centrifuged, resuspended and incubated in media containing CCCP. Samples were then centrifuged, resuspended, extracted and PDH kinase activity measured. See text for full details. Data shown are means \pm SEM for 8 assays. The PDH kinase activities at 15, 30 and 45min are all significantly greater than the zero time no substrate control ($P < 0.001$).

Figure 3.13 Time course for disappearance of pyruvate from mitochondrial incubation medium

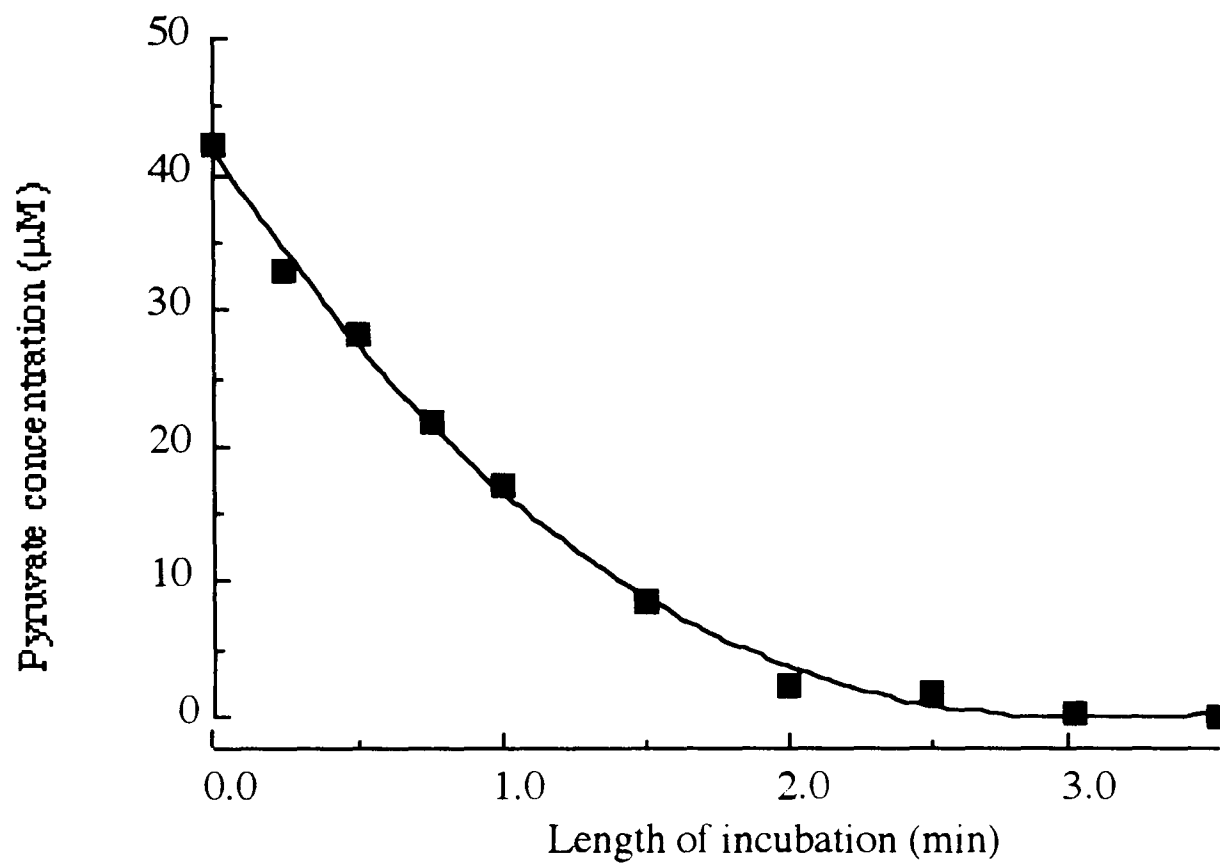

Following pre-incubation in KCl medium rat heart mitochondria were incubated in media containing $50\mu\text{M}$ -pyruvate (by weight) + 0.5mM -L-malate. Aliquots were taken at the times shown, deproteinised and the pyruvate concentration measured in resulting supernatants, by following NADH disappearance upon addition of lactate dehydrogenase. For further details see experimental. Each point is a single assay.

Figure 3.14 Time course for PDH kinase activities of mitochondria incubated with pyruvate maintained at $74\mu\text{M}$ by repeated additions of pyruvate

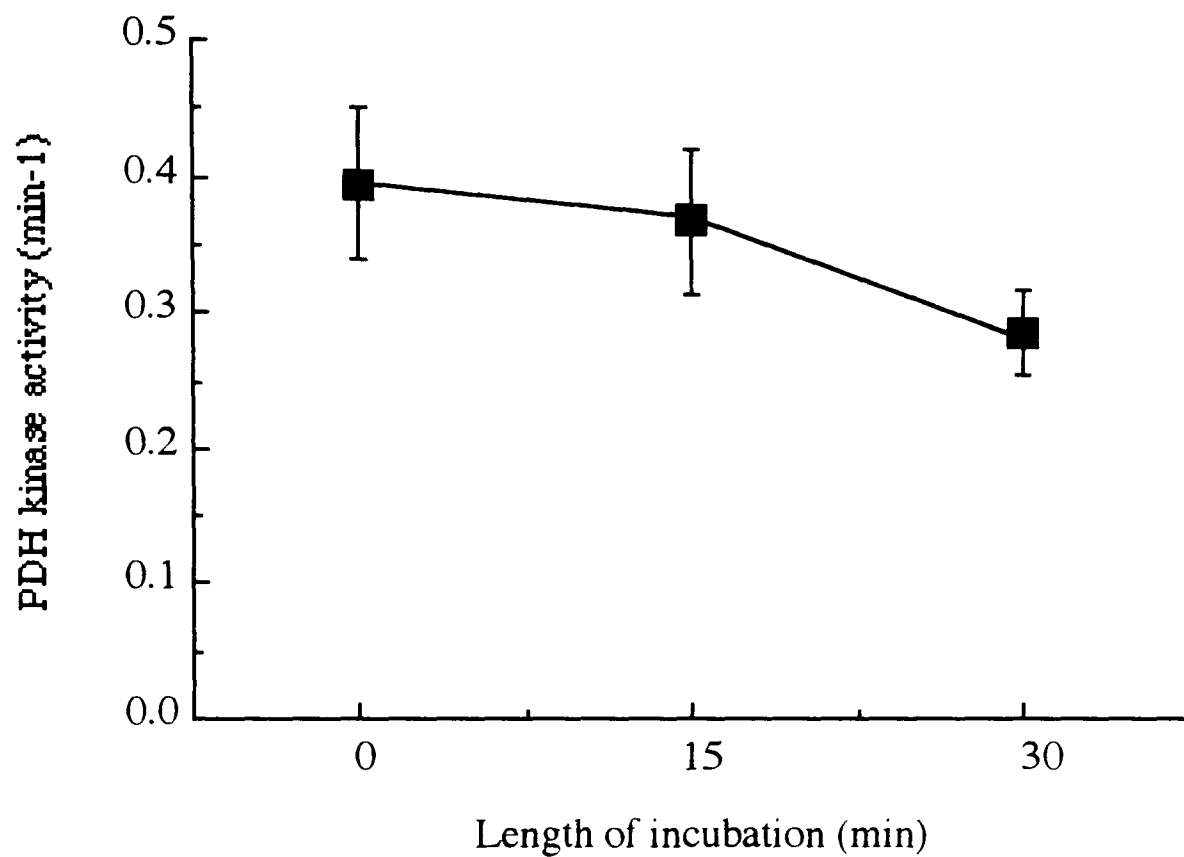

Following pre-incubation, rat heart mitochondria were incubated with pyruvate (plus 0.5mM-L-malate) maintained at a concentration of approx. $74\mu\text{M}$ by repetitive additions of stock pyruvate at 45s intervals. Samples were centrifuged, and the supernatants deproteinised and assayed for pyruvate. The pellets were resuspended, incubated in KCl incubation buffer containing CCCP, samples centrifuged, and the pellets resuspended, extracted and assayed for PDH kinase activity. For further details see experimental section. Data represent means \pm SEM for 4 assays at each time point.

Overall results Fig. 3.15 is a composite diagram displaying the effects of these respiratory substrates generating intramitochondrial acyl-CoA compounds on PDH kinase activities expressed as ratios to no substrate controls. With the exception of pyruvate which had no significant effect on PDH kinase activities there is perhaps no completely consistent difference between the others though palmitoyl carnitine/malate is perhaps marginally more effective than succinate or acetyl carnitine/malate or α -ketoglutarate/malate or α -ketoisocaproate/malate.

22 The effect of palmitoyl L-carnitine/L-malate on the activity of PDH kinase in rat heart mitochondria, *in vitro* under anoxia and in the presence of rotenone.

In the sections above it was shown that heart mitochondria incubated with palmitoyl carnitine and other respiratory substrates, that form acyl-CoA and acetyl-CoA, can enhance the activity of PDH kinase, and the greatest enhancement was with palmitoyl carnitine. Formation of acetyl-CoA from palmitoyl carnitine is dependent upon the availability of NAD⁺ and FAD⁺. A decrease in [NAD⁺] and [FAD⁺] relative to [NADH] and [FADH] is found if electron transfer, via the electron transport chain, is inhibited. 1 μ M-rotenone inhibits NADH dehydrogenase and completely inhibits respiration, but allows succinate to be subsequently oxidised. Rotenone was added to incubations, and was also added in combination with blowing nitrogen gas over incubations, to expel air and make conditions anoxic (inhibits transfer of the electrons in the terminal step thus completely inhibiting respiration).

Effect of rotenone on the disappearance of palmitoyl carnitine from the incubation medium Palmitoyl carnitine was degraded in the presence of rotenone. The concentrations of L-carnitine in incubation media, following 60min incubation in which 100 μ M palmitoyl carnitine was added in total (50 μ M at 0 and 30min), were 103 μ M \pm 4.9 (n=6) without rotenone and 81 μ M \pm 2.3(n=6) with rotenone (mean \pm SEM for the number of incubations (n)).

Effect of rotenone or rotenone and anoxia on palmitoyl carnitine enhancement of PDH kinase activity Table 3.4 shows that palmitoyl carnitine enhances PDH kinase activity in the presence of rotenone \pm anoxia (expelling air from media and incubation tube with nitrogen gas).

Figure 3.15 Composite Histogram comparing effects of palmitoyl carnitine (PC), succinate (SU), α -ketoglutarate (KG), α -ketoisocaproate (KI), acetyl carnitine (AC) and pyruvate (PY) [+L-malate except succinate] on PDH kinase activity in heart mitochondria from fed rats.

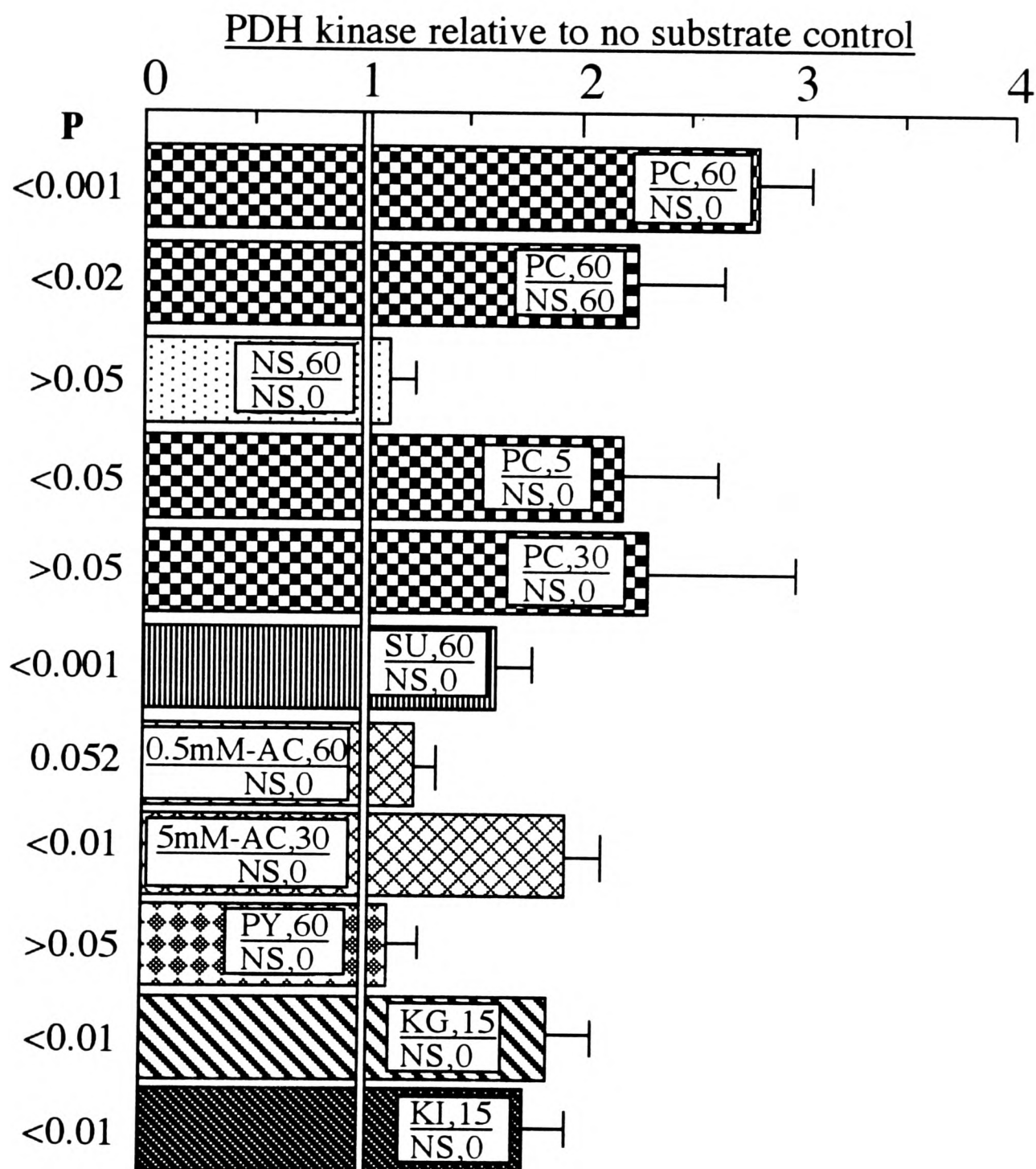

Following pre-incubation, rat heart mitochondria were incubated for the time shown (min) with the respiratory substrates as shown. After incubation with respiratory substrates mitochondria were sedimented, incubated in KCl medium containing CCCP, samples centrifuged, and the pellets resuspended, extracted and assayed for PDH kinase activity. For further details see experimental section.

Table 3.4 Ratios of PDH kinase activities; effect of palmitoyl-L-carnitine incubation of rat heart mitochondria under anoxia and in the presence of rotenone

<u>PC</u>	<u>PC+</u>	<u>PC++</u>	<u>PC+</u>	<u>PC++</u>
NS	NS+	NS++	PC	PC
2.5±0.15(8)	5.7±0.32(14)	2.1±0.31(9)	1.3±0.07(11)	1.04±0.09(10)

'PC' = palmitoyl L-carnitine, 'NS' = no substrate control, '+' = with rotenone and '++' = with anoxia and rotenone. §=P<0.001, †=P<0.01, *=P<0.05.

Following pre-incubation rat heart mitochondria were incubated with 50µM-palmitoyl-L-carnitine + 0.5mM L-malate in the presence or absence of 100µM-rotenone ± anoxia, at 30°C for 60min (with a further addition of 50µM-palmitoyl carnitine at 30min). At the end of the incubation, mitochondria were separated from incubation media, by centrifugation, resuspended and incubated with KCl medium containing CCCP. Mitochondria were sedimented, extracted and the PDH kinase activity measured. Details are given in the experimental section. Data are from 4 mitochondrial preparations.

DISCUSSION

Kerbey *et al.* (1976) showed that with isolated rat heart mitochondria incubated with respiratory substrates that the proportion of active PDH complex was decreased. The results of the experiments presented in this chapter show that rates of ATP-dependent inactivation of PDH complex are increased by incubation of isolated rat heart mitochondria with respiratory substrates in comparison with control mitochondria incubated without substrate. PDH kinase activities in extracts of control mitochondria remained stable throughout 60min of mitochondrial incubation compared with activities from extracts of mitochondria preincubated only and PDH complex activities were stable during kinase assays where extracts were incubated for up to 7min at 30°C without ATP. The largest increase in PDH kinase activity was found with palmitoyl-L-carnitine plus L-malate, but increases were found with succinate, α -ketoglutarate plus L-malate, acetyl-L-carnitine (at 5mM) plus L-malate and 0.5mM-acetyl-L-carnitine plus L-malate may have some effect. Pyruvate plus L-malate, even at a constant concentration was without effect. This is in contrast with previous results where, in the presence of TPP pyruvate at low concentrations ($<100\mu\text{M}$) activated the complex (Cooper *et al.*, 1974), and at high concentrations inhibited PDH kinase (Linn *et al.*, 1969; Cooper *et al.*, 1974). The mechanism, in purified heart preparations, involves reductive acetylation of lipoate (Ravindran *et al.*, 1996), and it is likely that this is the mechanism of activation in rat heart mitochondria found by Cooper *et al.* (1974). In the experiments presented here mitochondria were incubated with uncoupler which removes the PDH kinase from these effectors and thus the PDH kinase activity was as expected no greater than that found with no substrate controls.

The results of the experiments in this chapter showed that palmitoyl-L-carnitine activation PDH kinase was stable as it survived incubation with uncoupler (CCCP) and extraction into extraction medium with repeated freezing and thawing which would decrease the metabolite concentration ratios that for purified pig heart PDH kinase would effect an increase in activity. It is not associated with an increase in the mitochondrial ATP concentration as a diminution in the proportion of active (dephosphorylated) PDH complex was found in the absence of any increase

in the ratio of [ATP]/[ADP] or of [NADH]/[NAD⁺] (Kerbey *et al.*, 1977).

Further support that the mechanism of activation of the kinase does not involve a product of fatty acids, comes from the results of the experiments here where mitochondria were incubated in the presence of inhibitors of oxidative phosphorylation (rotenone and anoxia). Palmitoyl carnitine is as effective in their presence as in their absence. That metabolites are unnecessary for the palmitoyl carnitine activation of PDH kinase has been shown by other work in this laboratory where PDH kinase activities were measured in extracts of palmitoyl carnitine incubated rat heart mitochondria following gel filtration (PD10 column) which separates NADH, NAD⁺, acetyl-CoA and CoA from the kinase. PDH kinase activities in palmitoyl carnitine incubated mitochondria were at least 2-fold greater than that from no substrate incubated control mitochondria (results not given).

48h starvation of rats also results in a stable increase in PDH kinase activity and has been found in mitochondrial extracts prepared from these animals (Hutson and Randle, 1978; and results here), and in cardiac myocytes (Marchington *et al.*, 1990). The increase is independent of metabolite concentration ratios as decreases were effected in mitochondria which had been preincubated without substrate. With cardiac myocytes prepared from fed rats, incubated with palmitate albumin increased the PDH kinase activity to the level found with myocytes prepared from 48h starved rats. Palmitoyl carnitine incubation of mitochondria from fed rats here increased the PDH kinase activity to the level seen in 48h starved rat heart mitochondria. However, it is unlikely that the activation of PDH kinase by palmitoyl carnitine incubation of isolated mitochondria is mediated by the same mechanism as that with 48h starvation, as there was further activation of PDH kinase in palmitoyl carnitine incubated mitochondria prepared from these animals and because the two time courses for activation of PDH kinase are very different. Activation of kinase by starvation (*in vivo*) requires hours, whereas activation is apparent within 5min incubation of mitochondria with palmitoyl carnitine. With long term culture of cardiac myocytes with dibutyryl cAMP increased the PDH kinase to the level of that found with starvation (Marchington *et al.*, 1990). Similar results were found with cultured hepatocytes (Priestman *et al.*, 1994) and the cAMP effect was blocked with cyclohexamide.

This indicated that protein synthesis is needed for the cAMP effect in hepatocytes which was separate from the effect of palmitate which required functional mitochondrial carnitine acyl transferase. It was suggested that the mechanism of activation of PDH kinase may be by protein acylation; palmitate or a derivative may bind directly to the kinase and that greater level of cAMP may stimulate production of the acylating enzyme. In early experiments with purified pig heart complex and kinase incubated with 0.5mM-palmitoyl-L-carnitine had no effect on the kinase. At this concentration palmitoyl carnitine could form micelles (Tippet and Neet, 1982) and by acting as detergents have an effect on the kinase activity. The results of others and those presented here may be seen to support the view that acylation may be involved. Mitochondria would then presumably contain the acylating enzyme which would be removed by purification.

Muscle intracellular acyl-CoA concentrations are increased by starvation, diabetes and perfusion of hearts from normal fed rats with fatty acids (Garland and Randle, 1964b). It was of important to ascertain whether similar increases in the rates of ATP-dependent inactivation of the PDH complex could be found with incubation of mitochondrial extracts with palmitoyl-CoA. This forms the basis of the experiments presented in chapter 4.

Chapter 4

Effect of palmitoyl-CoA on activity of pyruvate dehydrogenase kinase in rat heart mitochondrial extracts

INDEX

	Page
Introduction	4.3
Materials and Methods	4.4
1 Materials	4.4
2 Solutions	4.4
3 Rats	4.4
4 Preparation of rat heart mitochondria	4.5
5 Preparation of mitochondrial extracts	4.7
6 Incubation of mitochondrial extracts	4.7
7 Assay of pyruvate dehydrogenase (PDH) complex activity	4.8
8 Assay of PDH kinase activity	4.8
9 Preparation of samples for assay of CoA concentration	4.8
10 Assay of palmitoyl-CoA	4.9
11 Definition of enzyme activity	4.9
12 Expression of results and statistical analysis	4.9
Results and Discussion	4.10
13 Effect of palmitoyl-CoA incubation of rat heart mitochondrial extracts on activity of PDH kinase activity	4.10
14 Effect of palmitoyl-CoA/palmitoyl L-carnitine incubation of extracts of heart mitochondria from fed and 48h starved rats on PDH kinase activities	4.13
15 Effect of palmitoyl-CoA on the PDH kinase activity in extracts prepared from mitochondria incubated \pm palmitoyl L-carnitine	4.15
Conclusions	4.16

INTRODUCTION

PDH kinase activity is increased *in vivo* by starvation and diabetes, in isolated complex by increasing concentration ratios of $[NADH]/[NAD^+]$ and $[acetyl-CoA]/[CoA]$ and by decreases in ADP, TPP and pyruvate, and increased in long term culture of myocardial cells by cAMP and fatty acids. In the previous chapter a stable increase in PDH kinase was found with rat heart mitochondria incubated with palmitoyl-L-carnitine, succinate, α -ketoglutarate and α -ketoisocaproate and high concentrations of acetyl-DL-carnitine. Palmitoyl carnitine is the cytosolic form of palmitate (apart from unbound palmitate in intracellular stores or triacylglycerol). It is the form of palmitate that permits its entry into mitochondria. The transportation system of palmitate involves two carnitine acyl transferases located on the outer and inner membranes of the mitochondrion and are connected by a carnitine acyl transport carrier. Carnitine acyl transferase I, with CoA and ATP, catalyses the reaction that binds cytosolic palmitate to carnitine, AMP and PP_i . Palmitoyl carnitine traverses the mitochondrial membrane via the carrier to the second carnitine acyl transferase which converts of palmitoyl carnitine to palmitoyl-CoA in the inner matrix. In this form palmitate can be utilised by the intra mitochondrial enzymes such as those involved with β -oxidation of fatty acids or more strictly fatty acyl-CoA. The results of the previous chapter provide evidence that incubation of rat heart mitochondria with palmitoyl carnitine (and succinate and high concentrations of acetyl carnitine, α -ketoglutarate, or α -ketoisocaproate) lead to a stable activation of PDH kinase as measured by ATP dependent inactivation of the PDH complex. The experiments presented in this chapter show that incubation of disrupted or extracted mitochondria with palmitoyl-CoA also increases PDH kinase activity. Mitochondria were depleted of endogenous substrate by preincubation, separated from incubation medium and then rapidly frozen, quickly thawed and resuspended in buffer (containing protease inhibitors and thiol maintaining compounds) and rapidly frozen and thawed twice more. This has the effect of disrupting the mitochondrial membranes allowing assays of PDH complex and PDH kinase activities, employing added substrates, coenzymes and activators or inhibitors.

MATERIALS and METHODS

1 Materials

The sources of all chemicals and biochemicals were as those described in section 1 of chapter 3, with the following additions. Palmitoyl-CoA (n-Hexadecanoyl Coenzyme A, free acid) was purchased from Sigma Chemical Co Ltd, Fancy Road Poole, Dorset, U.K. Purified pig heart PDH complex was isolated from pig hearts in this laboratory according to the method given by Kerbey *et al.* (1979) and aliquots were stored at -80°C.

2 Solutions

Solutions were prepared as described in the previous chapter, with the following additions. The stock solution of 1mM-palmitoyl-CoA was made with extraction buffer (50mM-KH₂PO₄/10mM-EGTA/2mM-DTT/1mM-MgCl₂/0.5mM-TLCK/1mM-benzamidine/10μM-leupeptin, pH 7.0 containing 50μg-oligomycin B/ml) on the day of use. A mixture of the additions to pyruvate dehydrogenase assay buffer with fluoride (PABF) required for the CoA assay (72mM-TPP, 36mM-NAD⁺ and 73mM-pyruvate) was made and stored in 1ml aliquots at -20°C. A fresh aliquot was used for each day's analyses. A standard solution of 1mM-CoA (gravimetric measurement) was made and the concentration more accurately measured spectrophotometrically at 260nm.

Measurement of concentration of stock CoA solution A sample of stock CoA solution was added to a quartz cuvette containing 50mM-KH₂PO₄ pH 7.0, and mixed. The concentration was calculated from the absorbance against air and a blank reading for the absorbance at 260nm. (mM-extinction coefficient for CoA of 16.0cm⁻¹ (Beaucamp *et al.*, 1974).)

3 Rats

Male albino Wistar rats were used weighing greater than 300g. Details of maintenance and diet are described in section 6 of chapter 3.

4 Preparation of rat heart mitochondria

In the preceding chapter a method was described for isolating mitochondria from rat hearts which were then incubated at 30°C with substrates for periods up to 1h. PDH kinase activities were measured in extracts of these mitochondria, following conversion of inactive complex (by incubation with uncoupler mitochondria) mitochondria, separation from incubation media, and extraction. The length of time for each kinase assay was, at most, 6min. In this chapter the mitochondrial extracts themselves were incubated for up to 1h. The presence of any residual Nagarse in the assay may have degraded the kinase or complex resulting in falsely low rates of inactivation. It was necessary, therefore, to use the alternative method of isolating mitochondria from rat hearts that does not involve proteases. The method used is described by Kerbey *et al.* (1976) and is given below.

Rats were anaesthetised with an intraperitoneal injection of sodium pentobarbitone or Sagatal™ (4ml/kg of body weight). An incision was made to the lower abdomen and cut toward the head through the rib cage. Beating hearts were excised from the body cavity and immediately submerged in ice cold sucrose buffer (250mM-sucrose/5mM-Tris/2mM-EGTA, pH7.4 when ice cold). Most blood was washed away by this. The heart chambers were opened by a cruciform cut through most of the tissue, blotted on Whatman no4 filter paper to remove excess blood and trimmed of large blood vessels and fat. After rinsing, by resuspending/settling under gravity to remove residual blood, hearts were chopped finely in a small volume of sucrose buffer and transferred to a glass homogeniser. Muscle cells were disrupted in sucrose buffer, approx. 5ml/heart using a polytron homogeniser (PT10-35) set at position 5 for <1 sec, 2 or 3 times. The homogenate was diluted to fill the centrifuge tube (approx. 35 ml) and centrifuged (MSE 18; 8 x 50ml fixed angle rotor) at 500g for 9min at 4°C. The supernatant was pipetted into a fresh centrifuge tube. The pellet was resuspended using the polytron as before and centrifuged as before along with the first supernatant. Pellets were discarded and supernatants were centrifuged at 10 000g for 9min. Loose material on pellets from the higher speed spin was removed by gently washing 2ml sucrose buffer over the surface of the pellet and aspirating the wash. Pellets were resuspended (mini glass rod which was actually a Pasteur pipette with a sealed curved tip)

in sucrose buffer and centrifuged at 10 000g for 9min and the step repeated once more. The final mitochondrial pellet was resuspended in KCl incubation buffer (120mM-KCl/20mM-Tris/5mM-EGTA/5mM-KH₂PO₄, pH 7.4) to approx. 1ml/1-2-hearts.

Preincubation of mitochondria Isolated mitochondria in KCl incubation buffer (120mM-KCl/20mM-Tris/5mM-EGTA/5mM-KH₂PO₄, pH 7.4) were pre-incubated (10min, 30°C, and aerated by swirling the tube gently every 20s) to deplete mitochondria of endogenous substrate and to effect conversion of inactive (phospho) PDH complex to active (dephospho) complex.

Assessment of purity of mitochondria The purity of the mitochondrial preparation was assessed by measuring the specific activity of PDH complex (mU/mg protein). A sample of 25μl of mitochondria was added to 75μl extraction buffer (50mM-KH₂PO₄/10mM-EGTA/2mM-DTT/1mM-MgCl₂/0.5mM-TLCK/1mM-benzamidine/10μM-leupeptin, pH 7.0) and rapidly frozen in liquid nitrogen and thawed a total of three times. PDH complex activity (see section 7) and protein concentration (Gornall *et al.*, 1949) were measured. Mitochondrial preparations generally had specific activities of approx. 100mU-PDH complex activity/mg mitochondrial protein.

Mitochondria were aliquoted into cryotubes and rapidly centrifuged (eppendorf centrifuge; 13 000g, 30s, room temperature), supernatants aspirated using a hypodermic needle attached to a vacuum water pump, and the pellets immediately frozen in and stored in liquid nitrogen until further use. In some experiments mitochondria were incubated with 50μM-palmitoyl carnitine/0.5mM-malate/0.1% fatty acid free BSA as described in detail below.

Frozen mitochondrial pellets were stored in liquid nitrogen for a maximum of 2 days before use and were generally used the following day. PDH kinase can remain fully active in mitochondrial pellets stored at a temperature of -20°C for up to 3 three weeks (results not shown).

Mitochondrial incubations with palmitoyl carnitine In these experiments mitochondria (depleted of endogenous substrate by preincubation, see above) were incubated in prewarmed KCl medium (120mM-KCl/20mM-Tris/5mM-EGTA/5mM-KH₂PO₄, pH 7.4) containing 50μM-palmitoyl carnitine, 0.5mM-malate and 0.1%-fatty acid free BSA at 200mU-PDH complex/ml for

15min at 30°C, swirling gently every 5min.

Activation of PDH complex of palmitoyl carnitine incubated mitochondria. Palmitoyl carnitine incubated mitochondria were separated from incubation medium by centrifugation (MSE18; 10 000g, 8min at 4°C). Supernatants were decanted and discarded. The mitochondrial pellet was resuspended (mini glass rod, see section 4) gradually incorporating KCl medium/10µM-CCCP to 1ml and then diluted with KCl medium/10µM-CCCP to give a PDH complex concentration of 200mU-PDH complex/ml. Samples tubes were then incubated at 30°C for 30min and the tubes gently swirled every 5min. Following CCCP incubation 1ml samples were aliquoted into cryotubes, and rapidly centrifuged (eppendorf centrifuge; 13 000g, 30s, room temperature), supernatants aspirated using a hypodermic needle and vacuum, and the pellets immediately frozen in and stored in liquid nitrogen.

5 Preparation of mitochondrial extracts

Mitochondrial pellets were thawed into 100µl extraction buffer (50mM-KH₂PO₄/10mM-EGTA/2mM-DTT/1mM-MgCl₂/1mM-benzamidine/10µM-leupeptin, pH 7.0 containing 50µg-oligomycin B/ml) at 30°C (water bath) and dispersed by repeated aspiration and ejection with a 250µl Hamilton syringe. Extraction was completed by further freezing and thawing (*i.e.* twice more). The extracts were prepared on the day of use and stored in liquid N₂ after the final freeze until used for assay.

6 Incubation of mitochondrial extracts

Mitochondrial extracts were diluted with prewarmed (30°C) extraction buffer (50mM-KH₂PO₄/10mM-EGTA/2mM-DTT/1mM-MgCl₂/1mM-benzamidine/10µM-leupeptin, pH 7.0 containing 50µg-oligomycin B/ml) ± further additions of 1mM-palmitoyl-CoA and of 0.5mM-palmitoyl carnitine to 10µM- or 50µM-palmitoyl-CoA/50µM-palmitoyl carnitine and 0.5mM-ATP. Extracts were incubated at 30°C (water bath) for the length of time indicated in each experiment. The activity of PDH kinase was measured at these times (*i.e.* samples were taken into Eppendorf tubes, minus ATP samples taken, ATP (10mM) added to 0.5mM and further

samples taken for PDH complex assay at suitable time intervals.

7 Assay of pyruvate dehydrogenase (PDH) complex activity

The activity of PDH complex was measured using the method described in section 10 of chapter 3.

8 Assay of PDH kinase activity

The PDH kinase activity was measured in incubated rat heart mitochondrial extracts by the method is given in section 11 of chapter 3.

9 Preparation of samples for assay of CoA concentration

Preparation of samples Samples were deproteinised by addition of HClO₄ to 5% (w/v) , allowed to stand on ice for 15min, and mixed vigorously (by hand and vortex). The extract was centrifuged (bench top centrifuge; swing out rotor, 2 000g, 2min, room temperature). The supernatant was decanted and brought to pH 7.0 with 10M-KOH (glass electrode) after addition of 1M-triethanolamine-HCl, pH 7.0. The samples were cooled on ice, the resulting KClO₄ precipitate was removed by centrifugation (as above) and the supernatant kept on ice for subsequent assay of CoA.

Assay of CoA CoA was assayed spectrophotometrically as NADH formed by the PDH complex reaction. The general reaction is as follows, where I is PDH complex

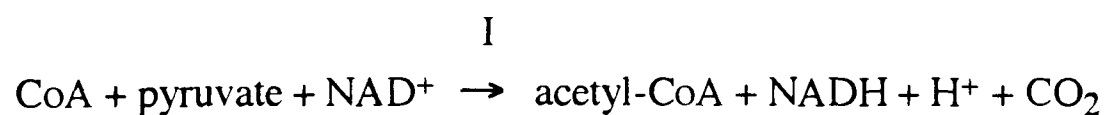

The PDH complex reaction with samples of purified PDH complex, free of lactate dehydrogenase and NADH oxidases, can be followed spectrophotometrically by monitoring NADH formation at 340nm. Samples containing CoA were added to cuvettes each containing PDH assay buffer (100mM-Tris/1mM-MgCl₂/0.5mM-EDTA/5mM-NaF) without dye, and 72mM-TPP, 36mM-NAD⁺ and 73mM-pyruvate, and the contents mixed (small glass rod). The

absorbance was noted (Abs1). 5mU-purified pig heart PDH complex was added and mixed. When the reaction was complete (no further increase in absorbance - approx. 3min) the second absorbance was noted (Abs2). The concentration of CoA was calculated from the difference in absorbance (Abs2-Abs1) and the mM-extinction coefficient for NADH of 6.22cm^{-1} allowing for dilutions and the blank.

With each day's analyses, the assay was checked by measuring the recovery of a standard 1mM-CoA solution measured spectrophotometrically, which averaged was generally greater than 80%.

10 Assay of palmitoyl-CoA

The concentration of palmitoyl-CoA was measured in HClO_4 precipitated mitochondrial extracts incubated in the presence or absence of palmitoyl-CoA. Samples were prepared as described in section 9 above. The precipitates from HClO_4 extracts was resuspended with 50mM- KH_2PO_4 pH 7.0 containing 25mM- β -mercaptoethanol. The pH was adjusted to pH 13.0 with 10M-KOH and the samples was heated to 45°C (water bath) for 8min to hydrolyse palmitoyl-CoA to palmitate and CoA. Incubation was terminated by acidification to pH1 with 62%- HClO_4 (using a glass electrode) and cooling on ice for 10min. Samples were clarified by centrifugation (as above) and supernatants were neutralised with 10M-KOH (pH test strips) and assayed for CoA (see section 9). Stock 1mM-palmitoyl-CoA was also diluted in analogous fashion and subjected to the same alkaline hydrolysis and treatment to assess the recovery of the procedure which was $53\pm 2.4\%$.

11 Definition of enzyme activity

1 Unit of enzyme activity is defined as the amount required to convert $1\ \mu\text{mol}$ of substrate to product in 1min at 30°C .

12 Expression of results and statistical analysis

Data are expressed as means \pm SEM together with the number of assays or the number of

experiments (mitochondrial preparations) given in parentheses. The results of identical experiments with different mitochondrial preparations were combined. The significance of differences between means was established by t-test using variance ratios to test for the significance of differences in variance between groups.

RESULTS and DISCUSSION

13 Effect of palmitoyl-CoA incubation of rat heart mitochondrial extracts on PDH kinase activity

Figure 4.1 and Table 4.1 clearly shows that incubation of extracts of rat heart mitochondria with palmitoyl-CoA increases PDH kinase activity above controls (extracts incubated with extraction buffer alone). The kinase activity of PDH kinase at 0min with 10 μ M-palmitoyl-CoA (with or without palmitoyl carnitine) shows an immediate effect. The increase on incubation with 10 μ M-palmitoyl-CoA is sustained but shows no further increase at 10 or 20min. Supplementing 10 μ M-palmitoyl-CoA with 50 μ M-palmitoyl carnitine induced the same zero time increase with palmitoyl-CoA alone but thereafter PDH kinase activity increased further at 10 and 20min incubation (up to 2.3 fold). The level of increase at 10 and 20min was similar to that with 50 μ M-palmitoyl-CoA alone or in combination with 50 μ M-palmitoyl carnitine (2.1-2.5 fold). The zero time kinase activity with 50 μ M-palmitoyl-CoA (both with or without palmitoyl carnitine) shows a decrease relative with the 10 μ M-palmitoyl-CoA which may indicate that palmitoyl-CoA at a higher concentration initially inhibits the kinase. Thus 50 μ M-palmitoyl carnitine addition with 10 μ M-palmitoyl-CoA increases kinase activity to the level observed with 50 μ M-palmitoyl-CoA. The results with 50 μ M-palmitoyl-CoA alone suggest that palmitoyl carnitine may act by sustaining palmitoyl-CoA concentration and thus prolonging the period of its action. The average of ratios of rate constants (50 μ M-palmitoyl-CoA/control) for most experiments was 0.99 as compared with 0.6 against 10 μ M-palmitoyl-CoA \pm 50 μ M-palmitoyl carnitine.

Statistical analyses (t-test) of the means was complicated by variance ratios exceeding the limit of the test, and these are marked in the table. This was a consequence of very low variances amongst zero time controls. In order to make meaningful deductions, further comparisons were made of means \pm SEMs of ratios of rate constants with unity. (Comparisons of ratios with unity allows for statistical significance to be calculated using a ratio.) (Individual extracts were prepared from frozen mitochondria (see section 5) and divided into three, one each for the

Figure 4.1 and Table 4.1 PDH kinase activities in mitochondrial extracts incubated with 10 or 50 μ M-palmitoyl-CoA, or 10 or 50 μ M-palmitoyl-CoA and 50 μ M-palmitoyl-carnitine or in extraction buffer alone

Mitochondria were depleted of endogenous substrate by incubation at approx. 1U-PDH complex/ml with KCl incubation medium (120mM-KCl/20mM-tris-HCl/5mM-KH₂PO₄/5mM-EGTA pH7.4) for 10min at 30°C (water bath) and swirled every 20s. PDH complex activity was measured in samples after extraction (see below). Mitochondria were diluted with KCl medium to 200mU-PDH complex/ml, aliquoted (1ml) into cryotubes and centrifuged (eppendorf centrifuge; 13 000g, 30s at room temperature). Supernatants were aspirated (hypodermic needle and vacuum) and pellets frozen in liquid nitrogen. Pellets were thawed and resuspended in extraction buffer (50mM-KH₂PO₄/10mM-EGTA/2mM-DTT/1mM-MgCl₂/0.5mM-TLCK/1mM-benzamidine/10 μ M-leupeptin pH7.0 containing 50 μ g-oligomycin B/ml), and frozen and thawed (x2), divided into three equal parts and kept frozen until use. Extracts were thawed and diluted with prewarmed extraction buffer containing 1mM-palmitoyl-CoA with or without 0.5mM-palmitoyl-carnitine, extraction buffer alone (control). Samples were taken and PDH kinase activities were measured at 0, 10 and 20min. (Final concentrations in kinase assays, after the addition of 10mM-ATP were 300mU-PDH complex/ml, 0.5mM-ATP, 10 or 50 μ M-palmitoyl-CoA and 50 μ M-palmitoyl-carnitine.)

Mitochondria were prepared in two separate experiments and combined. Data in both the figure and the table represent means \pm SEM for the number of observations (assays) in parentheses, for at least four runs of 0, 10 and 20min. 'PCoA' = palmitoyl-CoA incubated extracts, 'PC' = palmitoyl-carnitine was included in incubation medium and 'Control' = extracts incubated in extraction buffer alone. Results of statistical analyses are given in the table (4.1). Significant differences are marked § P<0.001, † P<0.01, * P<0.05, and comparisons were made between PDH kinase activities in extracts incubated with 10 μ M-palmitoyl-CoA alone, 50 μ M-palmitoyl-CoA, 10 μ M-palmitoyl-CoA and 50 μ M-palmitoyl-carnitine, or 50 μ M-palmitoyl-CoA and 50 μ M-palmitoyl-carnitine with control extracts incubated in extraction buffer alone. # = approx. t test P>0.05.

Figure 4.1 PDH kinase activities in mitochondria extracts incubated with 10 or 50 μM -palmitoyl-CoA alone, with 10 or 50 μM -palmitoyl-CoA and 50 μM -palmitoyl-carnitine, or with extraction buffer alone

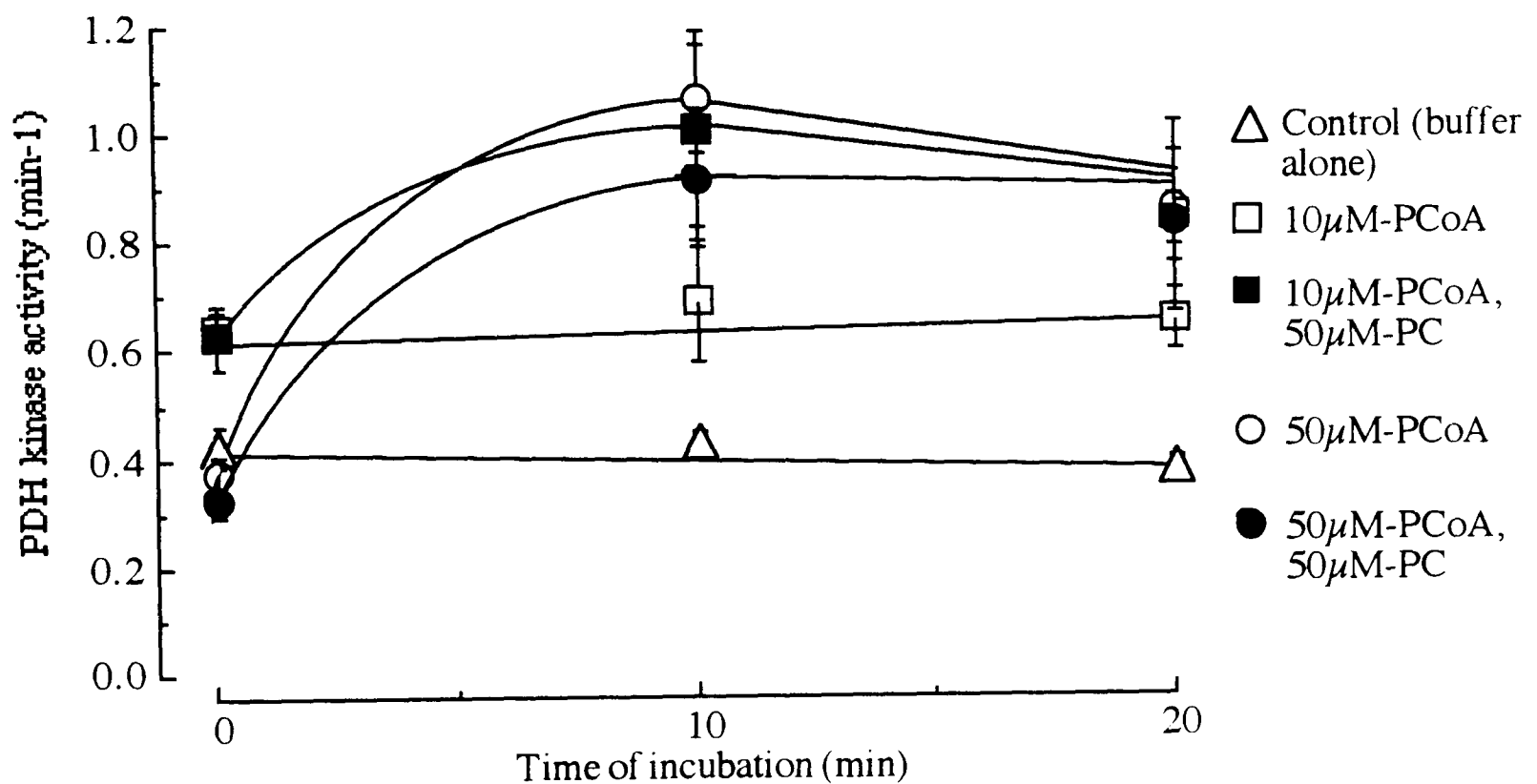

Table 4.1 PDH kinase activities in mitochondrial extracts incubated with 10 or 50 μM -palmitoyl-CoA alone, or 10 or 50 μM -palmitoyl-CoA and 50 μM -palmitoyl-carnitine, or in extraction buffer alone

Extract incubation medium	PDH kinase activities, rate constant (min^{-1})		
	0	10	20 min
10 μM -palmitoyl-CoA	$0.64 \pm 0.03(4)^\dagger$	$0.69 \pm 0.11(4)^\dagger$	$0.65 \pm 0.06(4)^\S$
10 μM -palmitoyl-CoA, 50 μM -palmitoyl-carnitine	$0.63 \pm 0.06(4)^*$	$1.01 \pm 0.18(4)^\#$	$0.84 \pm 0.18(4)^\#$
50 μM -palmitoyl-CoA	$0.37 \pm 0.03(5)$	$1.06 \pm 0.10(5)^\#$	$0.86 \pm 0.10(5)^\#$
50 μM -palmitoyl-CoA 50 μM -palmitoyl-carnitine	$0.32 \pm 0.03(5)$	$0.92 \pm 0.13(5)$	$0.84 \pm 0.05(5)^\S$
Control (extraction buffer)	$0.42 \pm 0.04(9)$	$0.43 \pm 0.02(9)$	$0.38 \pm 0.02(9)$

different conditions in the two experiments, 1) $10\mu\text{M}$ -palmitoyl-CoA \pm $50\mu\text{M}$ -palmitoyl carnitine and control and 2) $50\mu\text{M}$ -palmitoyl-CoA \pm $50\mu\text{M}$ -palmitoyl carnitine and control.) The results are given in Figure 4.2. The data shown are expressed as ratios of first order rate constants \pm SEMs at 0 and 10 min. $10\mu\text{M}$ -palmitoyl-CoA had an immediate effect to increase PDH kinase activity which was sustained at 10 and 20min but was only statistically significant at 20min. $10\mu\text{M}$ -palmitoyl-CoA with $50\mu\text{M}$ -palmitoyl carnitine showed the same increase at zero time but further increases at 10 and 20min (significant at $P < 0.05$ at 10min). With $50\mu\text{M}$ -palmitoyl-CoA, PDH kinase was unchanged at zero time and significantly increased at 10 and 20min; these differences persist unchanged in the presence of $50\mu\text{M}$ -palmitoyl carnitine.

Figure 4.3 show more prolonged progress curves for activation of PDH kinase in mitochondrial extract during incubations with $50\mu\text{M}$ -palmitoyl-CoA + $50\mu\text{M}$ -palmitoyl carnitine. The effect rose to a maximum at 10min and this was followed by a steady decline to a level still above the control levels at 60min ($P < 0.05$).

Figure 4.4 shows data similar to that presented in Figure 4.3 but displays means \pm their SEMs for individual experiments. The curves were drawn using the means calculated from all the individual rate constants at each time point. Graph a) shows the results from control incubations with extraction buffer alone as the incubation medium and shows no change in kinase activity after incubation for up to 60min at 30°C . (One point on this graph at 10min incubation appears to be much higher than the others and has a greater SEM. Its data are included in the calculation for the overall mean at 10min and is associated with an equally high mean for corresponding incubations with $50\mu\text{M}$ -palmitoyl-CoA and $50\mu\text{M}$ -palmitoyl carnitine in that particular experiment.) Graph b) shows results from all experiments in which mitochondrial extracts were incubated with $50\mu\text{M}$ -palmitoyl-CoA + $50\mu\text{M}$ -palmitoyl carnitine. It shows that zero time PDH kinase activity was unaffected by palmitoyl-CoA + palmitoyl carnitine addition but increased to a maximum at 10 and 15min and thereafter declined to a level at 60min which was only marginally above the controls.

Figure 4.5 show time courses for the disappearance of palmitoyl-CoA and the appearance of CoA during incubation of palmitoyl-CoA with mitochondrial extract (*i.e.* no palmitoyl

Figure 4.2 Ratios of first order rate constants for the effects of 10 or 50 μ M-palmitoyl-CoA and of palmitoyl carnitine on the activity of PDH kinase in rat heart mitochondrial extracts

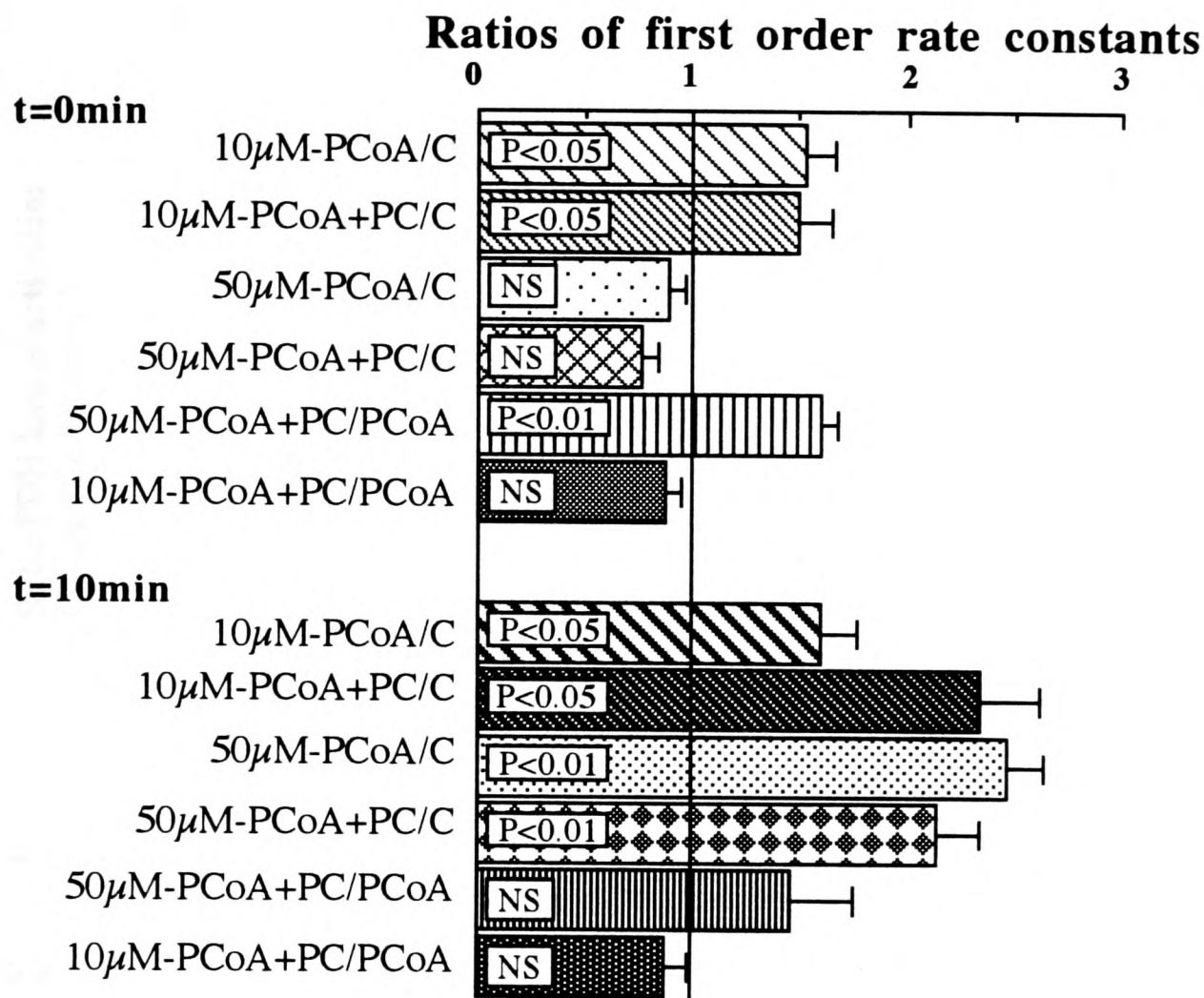

Mitochondria were preincubated with KCl incubation medium (at 1U/ml), a sample taken for PDH complex assay. Mitochondria were diluted to 200mU/ml with KCl medium, aliquoted and sedimented. Pellets were extracted in extraction buffer (50mM-KH₂PO₄/10mM-EGTA/2mM-DTT/1mM-MgCl₂/0.5mM-TLCK/1mM-benzamidine/10 μ M-leupeptin pH7.0 containing 50 μ g-oligomycin B/ml) with freezing and thawing and divided into three equal parts and kept frozen until use. Extracts were thawed and diluted with prewarmed extraction buffer containing palmitoyl-CoA with or without palmitoyl-carnitine, extraction buffer alone (control). (Final concentrations were 10 or 50 μ M-palmitoyl-CoA and 50 μ M-palmitoyl-carnitine.) Samples were taken and PDH kinase activities were measured at 0 and 10min. Data represent ratios of means \pm SEM for at least four runs. 'PCoA' = palmitoyl-CoA incubated extracts, 'PC' = palmitoyl-carnitine was included in incubation medium and 'control' = extracts incubated in extraction buffer alone. Significant differences are marked § P<0.001, † P<0.01, * P<0.05, and comparisons were made between ratios of rate constants for PDH kinase activities explained in figure and table with unity.

Figure 4.3 Time course for activation of PDH kinase activity in mitochondrial extracts incubated with 50 μ M-palmitoyl-CoA and 50 μ M-palmitoyl carnitine

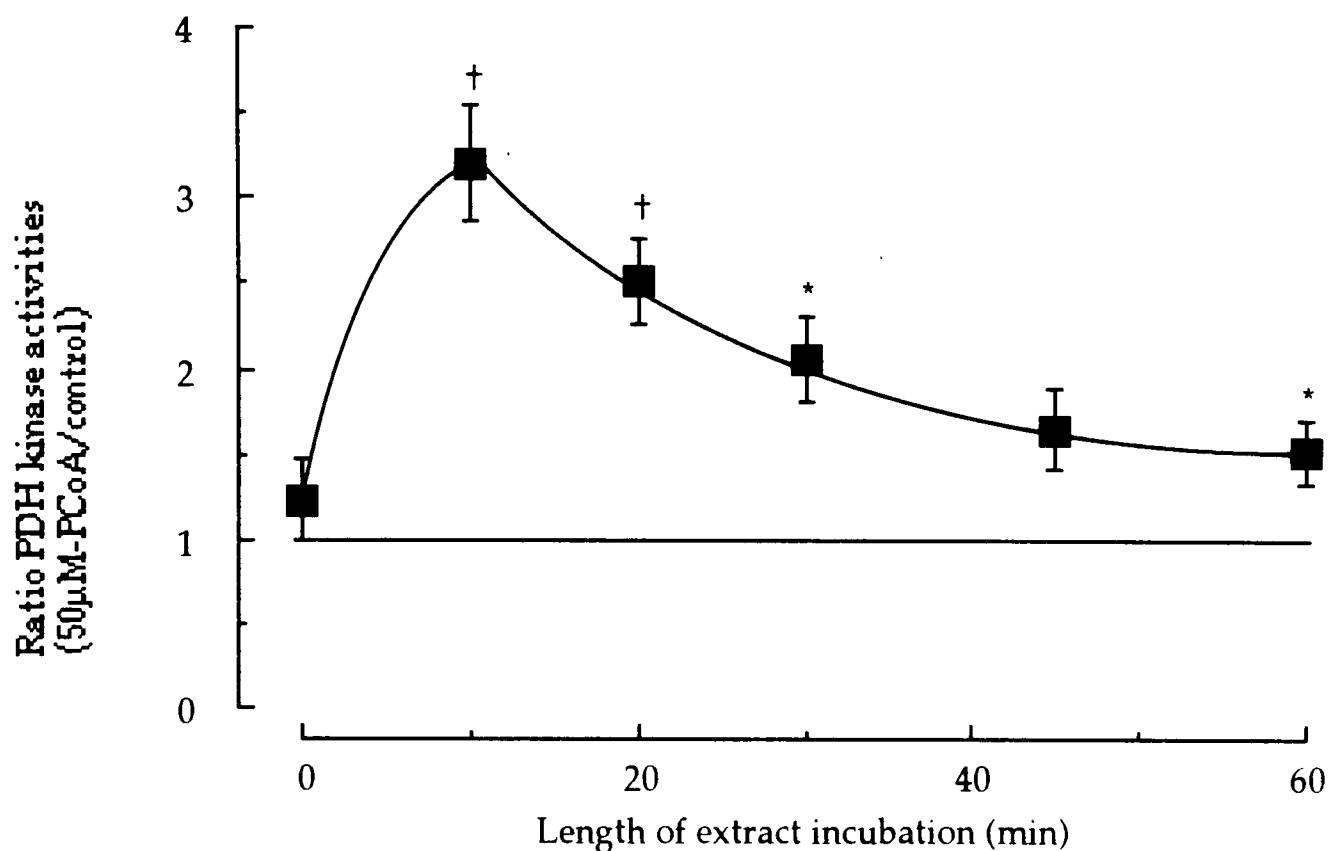

Mitochondria were preincubated with KCl medium (1U/ml). PDH complex concentration was measured in an extracted sample (see below) and mitochondria were diluted to 200mU-PDH complex/ml with KCl medium. Mitochondria were aliquoted into cryotubes and centrifuged. Pellets were thawed and resuspended with extraction buffer (50mM- KH_2PO_4 /20mM-EGTA/2mM-DTT/0.5mM-benzamidine/0.5mM-TLCK/1mM- MgCl_2 /10 μ M-leupeptin pH 7.0 containing 50 μ g-oligomycin /ml) and frozen and thawed twice more.

Extracts were incubated with prewarmed extraction buffer containing palmitoyl-CoA and palmitoyl-carnitine for up to 60min. (Final concentrations were 50 μ M-palmitoyl-CoA and 50 μ M-palmitoyl carnitine. Samples were taken periodically and assayed for PDH kinase activity (see section 8). Data represent means \pm SEMs for the ratios of PDH kinase activity {50 μ M-palmitoyl-CoA and 50 μ M-palmitoyl-carnitine/control} from single extracts divided in two and incubated with 50 μ M-palmitoyl-CoA and 50 μ M-palmitoyl-carnitine or controls incubated with extraction buffer alone. Mitochondria were from three separate preparations. * represents $P < 0.05$ and † $P < 0.01$ for the comparison of the ratio with unity.

Figure 4.4 PDH kinase activities in extracts of mitochondria from fed rats, incubated with $50\mu\text{M}$ -palmitoyl-CoA + $50\mu\text{M}$ -palmitoyl-L-carnitine or extraction buffer alone; data taken from all experiments

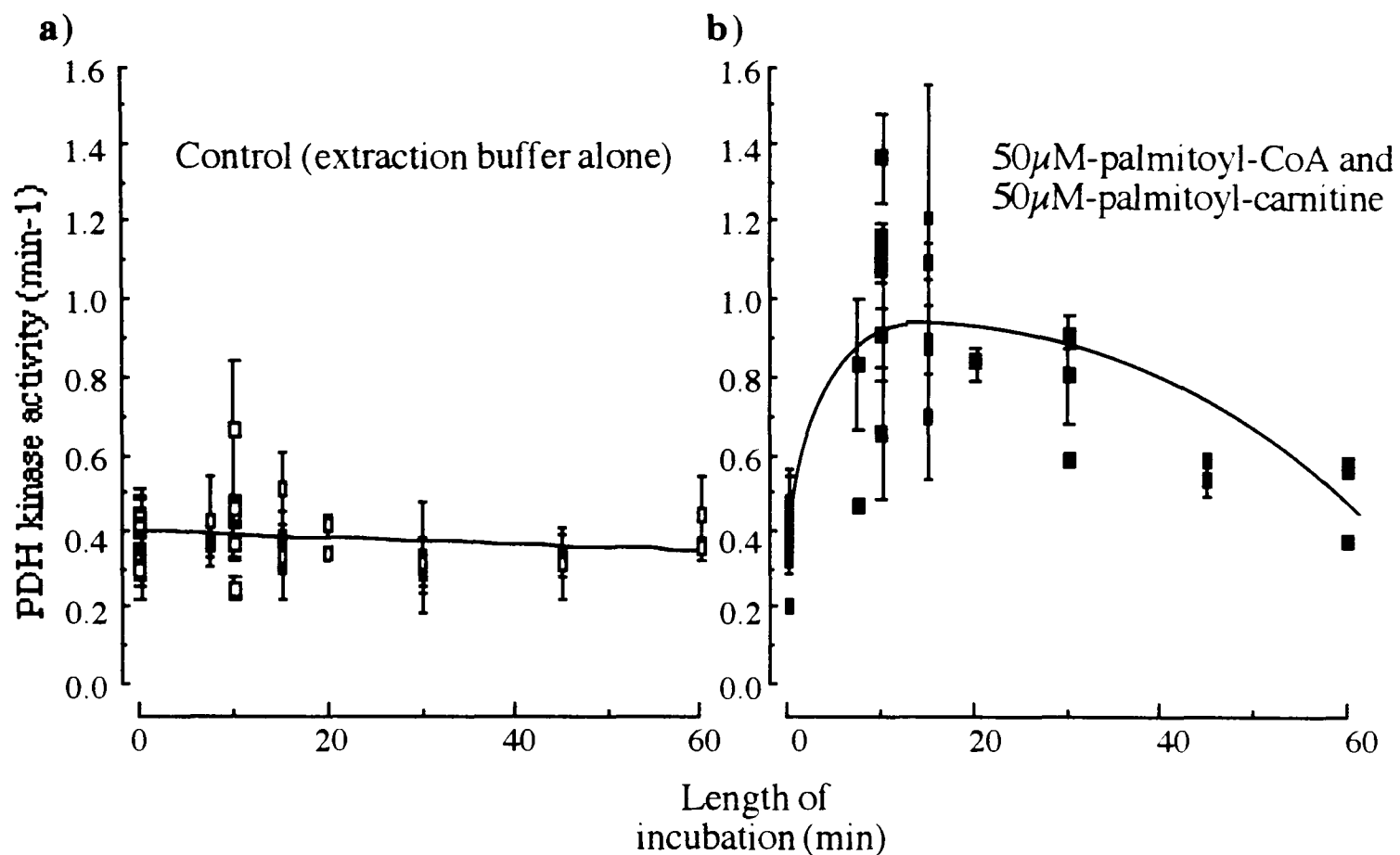

Mitochondria were preincubated with KCl medium (at 1U-PDH complex/ml). PDH complex was assayed in an extracted sample and mitochondria diluted to 200mU/ml, aliquoted, sedimented and pellets frozen. Pellets were extracted with extraction buffer with freezing and thawing (x2). Extracts were incubated with $50\mu\text{M}$ -palmitoyl-CoA + $50\mu\text{M}$ -palmitoyl-L-carnitine for up to 60min, during which samples were taken and assayed for PDH kinase activity (see section 8 of this chapter). Data represent means \pm SEMs for each experiment. Curves represent combined means \pm SEMs of all experiments.

Figure 4.5 Time course for palmitoyl-CoA disappearance and CoA appearance in extract incubation medium

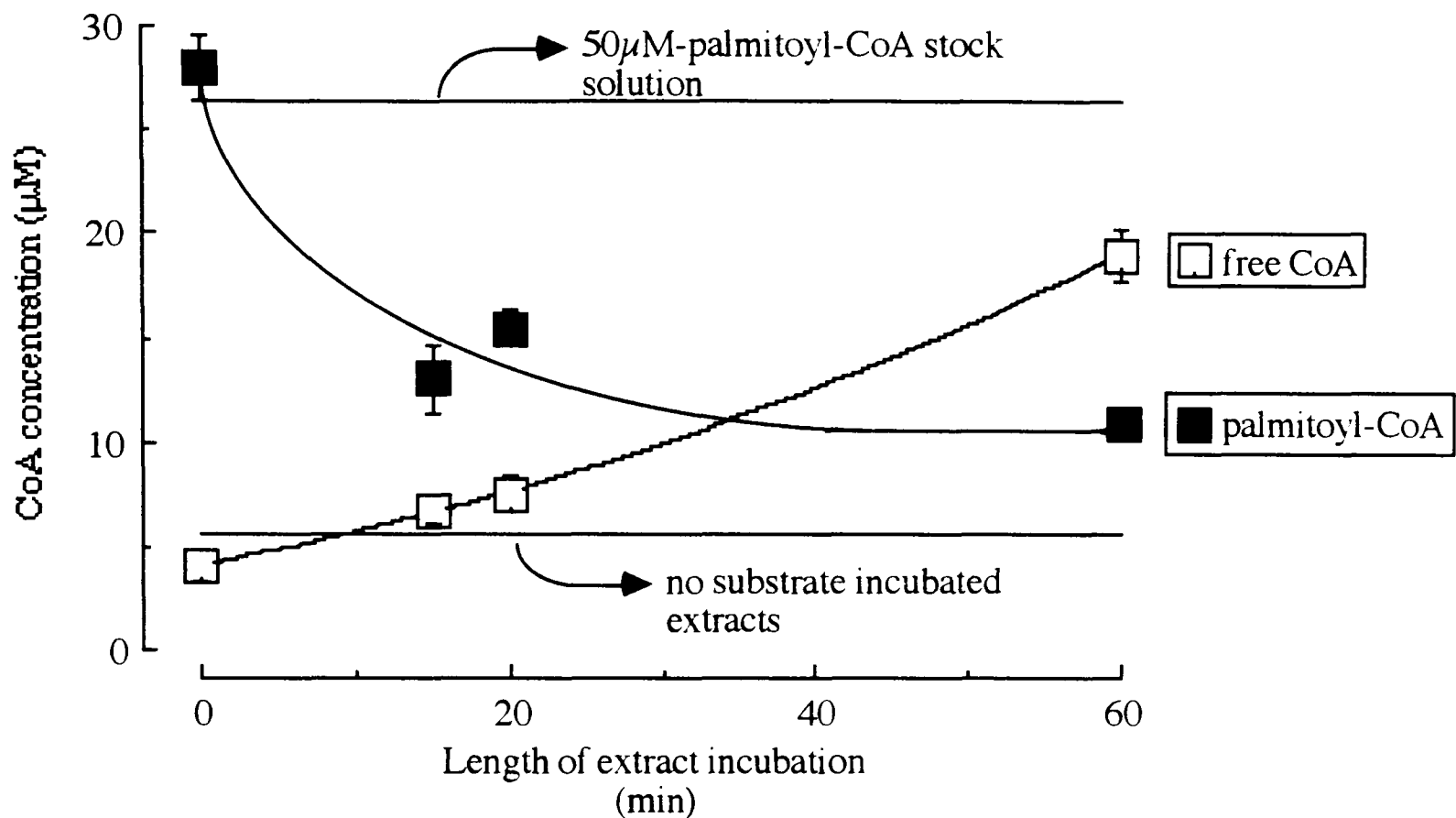

Mitochondria were preincubated with KCl medium and PDH complex activity was measured.

Mitochondria were diluted to 400mU-PDH complex/ml with KCl medium, aliquoted into cryotubes and rapidly centrifuged. Supernatants were aspirated and pellets frozen in liquid nitrogen over night. Each pellet was thawed and resuspended with 100µl extraction buffer (50mM-KH₂PO₄/10mM-EGTA/2mM-DTT/1mM-MgCl₂/0.5mM-TLCK/1mM-benzamidine/10µM-leupeptin, pH 7.0 containing 50µg-oligomycin B/ml) and frozen and thawed twice more combining all pellets after the last thaw before the final freeze.

PDH complex activity assayed. The extract was divided equally in two; to each sample was added prewarmed extraction buffer and to the other was added dropwise and with gentle stirring 1mM-palmitoyl-CoA (alone). Final concentrations were ~300mU-PDH complex/ml and 50µM-palmitoyl-CoA. Extracts were incubated for 20min at 30°C and gently swirled every 5min. Samples were taken immediately and at 15 and 60min, deproteinised with HClO₄ and after further processing the CoA content assayed (see section 9). Data represent means ± SEMs for three assays, except stock processed 50µM-palmitoyl-CoA solution where 5 separated dilutions and processing were made and assayed in triplicate. The curve labelled '50µM-palmitoyl-CoA stock solution' shows the concentration of CoA in a solution of stock 50µM-palmitoyl-CoA subjected to the same treatment as that that contained mitochondrial extract. The curve labelled 'no substrate incubated extract' shows the concentration of both CoA and PCoA in an incubation of mitochondrial extract incubated without adding palmitoyl-CoA stock solution. Mitochondria were from two preparations; one where measurements were made at 20min and the other at 0, 15 and 60min. P<0.05 for the difference between palmitoyl-CoA concentration at 60min and that with control incubated extracts.

carnitine was added). As a control, palmitoyl-CoA was measured in 50 μ M-palmitoyl-CoA solution incubated under otherwise comparable conditions but in the absence of mitochondrial extract. Free CoA was also measured in an incubation of mitochondrial extract in medium (extraction buffer) without added exogenous palmitoyl-CoA. These two sets of data are given for reference. The concentration of palmitoyl-CoA at the beginning of the experiment (0min) was not significantly different from the stock solution. The concentration of free CoA at this time was not significantly different from the endogenous concentration. The graph shows a rapid fall in the concentration of palmitoyl-CoA by 15min and continues to fall but more slowly to level at 60min greater than control ($P < 0.05$) which shows that some palmitoyl-CoA is present in the medium throughout the whole time period. The concentration of free CoA increased in reciprocal fashion with the palmitoyl-CoA concentration at 0 and 60min. The sum of the concentrations of palmitoyl-CoA and free CoA do not account for more than approx. 60% of the total amount of CoA (acylated or free) estimated to be present on a weight basis. If the concentration of free CoA is the underestimate then the time course for the disappearance of palmitoyl-CoA from the incubation medium shows good correlation with the time courses for the activation of PDH kinase.

Measurements such as these are difficult and involve large losses that have apparently been experienced by others. (The method used here was adapted from the method given in the thesis written by S Fuller where he described an underestimate of 40% for palmitoyl-CoA concentration.)

14 Effect of palmitoyl-CoA/palmitoyl L-carnitine incubation of extracts of heart mitochondria from fed and 48h starved rats on PDH kinase activities.

Data in Table 4.6 and Figure 4.6 show that PDH kinase activities of mitochondrial extracts from 48h starved rats were not significantly changed by 15 or 30min of incubation with 50 μ M-palmitoyl-CoA + 50 μ M-palmitoyl carnitine. There was a trend towards a decline in PDH kinase activity in the controls which was prevented by 50 μ M-palmitoyl-CoA + 50 μ M-palmitoyl carnitine, but the differences were not statistically significant. With extracts of mitochondria

Figure 4.6 and Table 4.6 PDH kinase activities in extracts of heart mitochondria, prepared from fed and 48h starved rats, incubated with 50 μ M-palmitoyl-CoA and 50 μ M-palmitoyl-carnitine

Mitochondria were preincubated at approx. 1000mU-PDH complex/ml with KCl medium to deplete mitochondria of endogenous substrate. PDH complex activity was measured in an extracted sample (see below). Mitochondria were diluted with KCl medium to 200mU-PDH complex/ml, aliquoted and centrifuged. Pellets were frozen and before use were thawed with extraction buffer (50mM-KH₂PO₄/10mM-EGTA/2mM-DTT/1mM-MgCl₂/0.5mM-TLCK/1mM-benzamidine/10 μ M-leupeptin at pH7.0 containing 50 μ g-oligomycin B) and frozen and thawed x2. Time course runs were performed as follows. A number of extracts containing sufficient PDH complex for two runs were combined and divided equally in two. To one portion was added prewarmed 0.5mM-palmitoyl-carnitine and 1mM-palmitoyl-CoA solutions to final concentrations of 50 μ M each, and extraction buffer was added to the other to dilute extracts by the same amount and both portions were mixed (vortex). Samples were taken from each into fresh eppendorfs, periodically, from which PDH kinase activities were measured. The final concentration of PDH complex and ATP in incubated extracts in kinase assays was 300mU/ml and 0.5mM respectively.

Two experiments were conducted. In each mitochondria were prepared from hearts from fed and 48h starved rats simultaneously and assays were performed, within an experiment, using the same materials, solutions, *etc.* Data represent combined means \pm SEM for two experiments. 'PCoA & PC' = extracts incubated with 50 μ M-palmitoyl-CoA and 50 μ M-palmitoyl-carnitine, and 'control' = extracts incubated with extraction buffer alone. # shows that t-test variance ratio exceeds limit of analysis, † P<0.01, * P<0.05 Subscripts demote comparisons of PDH kinase activities in incubated extracts from mitochondria and these are 1 = extracts, of mitochondria from fed rats, incubated with 50 μ M-palmitoyl-CoA and 50 μ M-palmitoyl-carnitine versus fed control incubated extracts, 2 = control incubated extracts, of mitochondria from 48h starved, versus controls from fed rats, 3 = control incubated extracts, from fed rats at t=15 or 30min versus that at t=0min, with extracts incubated with 50 μ M-palmitoyl-CoA and 50 μ M-palmitoyl-carnitine.

Figure 4.6 PDH kinase activities in extracts of heart mitochondria, prepared from fed and 48h starved rats, incubated with 50 μ M-palmitoyl-CoA and 50 μ M-palmitoyl-carnitine

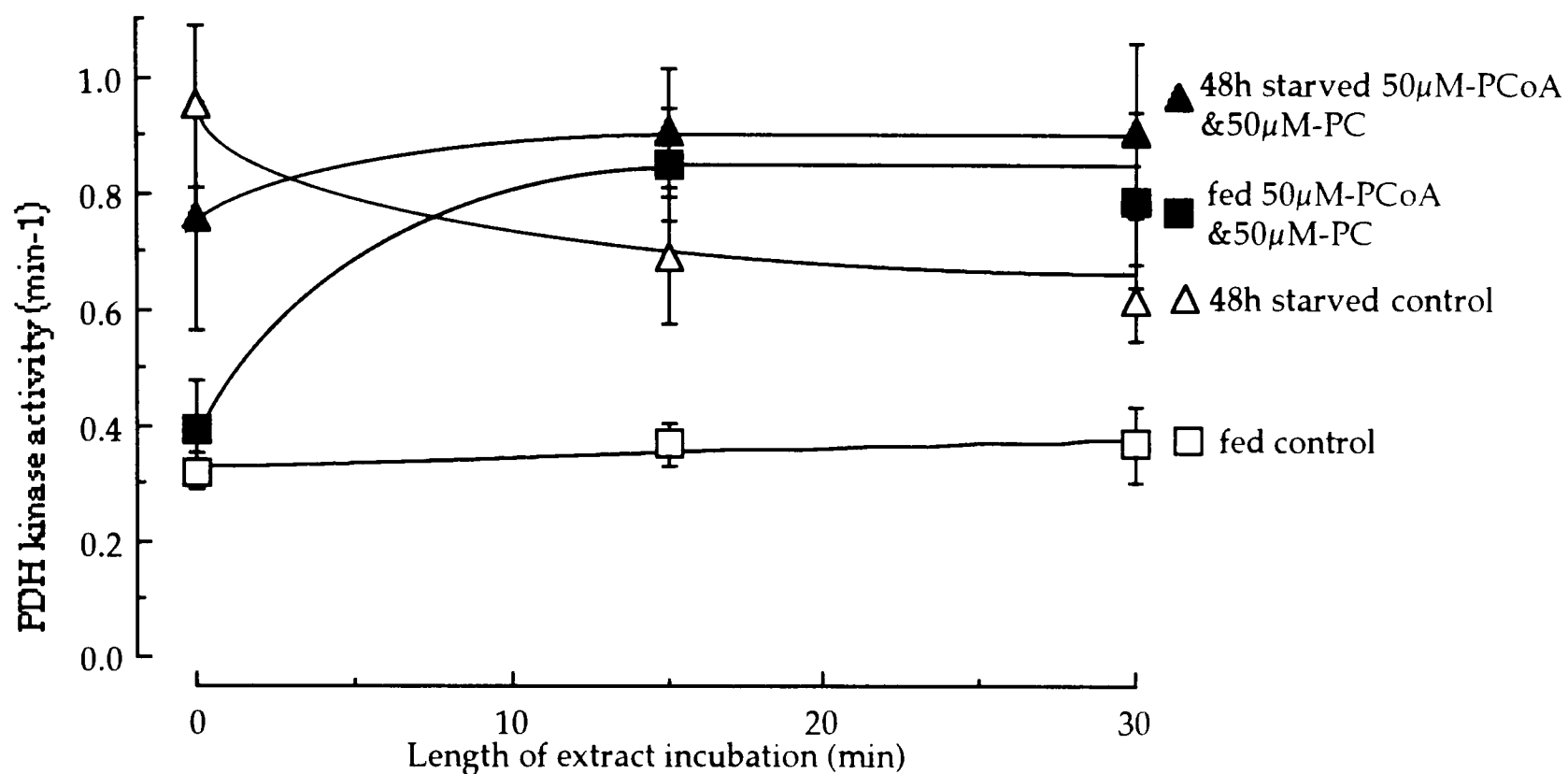

Table 4.6 PDH kinase activities in extracts of heart mitochondria, prepared from fed and 48h starved rats, incubated with 50 μ M-palmitoyl-CoA and 50 μ M-palmitoyl-carnitine or extraction buffer alone

	PDH kinase activity, rate constant (min ⁻¹)		
	0	15	30(min)
fed			
50 μ M-palmitoyl-CoA&50 μ M-palmitoyl-carnitine	0.39±0.09(7)	0.85±0.10(7)†3	0.78±0.20(7)*3
Control (extraction buffer)	0.32±0.03(7)#1	0.37±0.04(7)#1	0.37±0.07(7)*1
48h starved			
50 μ M-palmitoyl-CoA&50 μ M-palmitoyl-carnitine	0.78±0.20(7)	0.90±0.11(7)	0.91±0.15(7)
Control (extraction buffer)	0.95±0.14(7)#2	0.70±0.12(7)#2	0.61±0.07(7)*2

from hearts of fed rats, PDH kinase activity was increased twofold by 15 or 30min incubation with 50 μ M-palmitoyl-CoA + 50 μ M-palmitoyl carnitine. The interpretation of fed-starved differences in kinase activity were made difficult by differences in variance which could be largely avoided by calculating ratios \pm SEM for [(PCoA + PC)/(control)] and for [48h starved/fed]. These data are shown in Figure 4.7. The upper panel shows ratios of rate constants for [palmitoyl-CoA + palmitoyl carnitine]/ control for fed rats and 48h starved rats. In fed rats 15 and 30min of incubation with 50 μ M-palmitoyl-CoA + 50 μ M-palmitoyl carnitine induced a twofold increase in the ratio ($P < 0.01$), whereas in the starved the 1.5- and 1.8-fold increases in ratio at 15 and 30min, which could be accounted for by a reversal of the decline of kinase activity seen in the controls, were not significant ($P > 0.05$). The ratio of rate constants (starved/fed) fell in the control incubations from 3 at zero time to ~ 2 at 15min and to ~ 1.5 at 30min. The ratio of rate constants (starved/fed) was 2 at zero time and decreased on incubation with 50 μ M-palmitoyl-CoA + 50 μ M-palmitoyl carnitine to 1.12 at 15min and to 1.16 at 30min. These data suggest that in mitochondrial extracts from fed rats, 50 μ M-palmitoyl-CoA + 50 μ M-palmitoyl carnitine increase PDH kinase activity to levels comparable with those observed in extracts of mitochondria from starved rats incubated with 50 μ M-palmitoyl-CoA + 50 μ M-palmitoyl carnitine. In extracts of mitochondria the data suggested that 50 μ M-palmitoyl-CoA + 50 μ M-palmitoyl carnitine might prevent the decline in PDH kinase activity. It is unfortunate that lack of time prevented more extensive replication of these results.

These data are potentially important in relation to the effect of starvation to increase the activity of PDH kinase in heart mitochondria. In chapter 3 it was shown that palmitoyl carnitine increased PDH kinase to a comparable degree in intact mitochondria from fed or starved rats and it seemed unlikely therefore that this particular phenomenon could play a part in the fed - starved difference in PDH kinase activities. However, the effects of palmitoyl-CoA in extracts of mitochondria described here are compatible with a possible role for the effect of starvation *in vivo* and of palmitate in tissue culture to increase PDH kinase activity. It was important therefore to ascertain whether palmitoyl-CoA + palmitoyl carnitine increased PDH kinase in extracts of whole mitochondria incubated with palmitoyl carnitine.

Figure 4.7 Ratios of first order rate constants for PDH kinase activities in extracts of heart mitochondria prepared from fed and 48h starved rats, incubated with 50 μ M-palmitoyl-CoA + 50 μ M-palmitoyl-L-carnitine

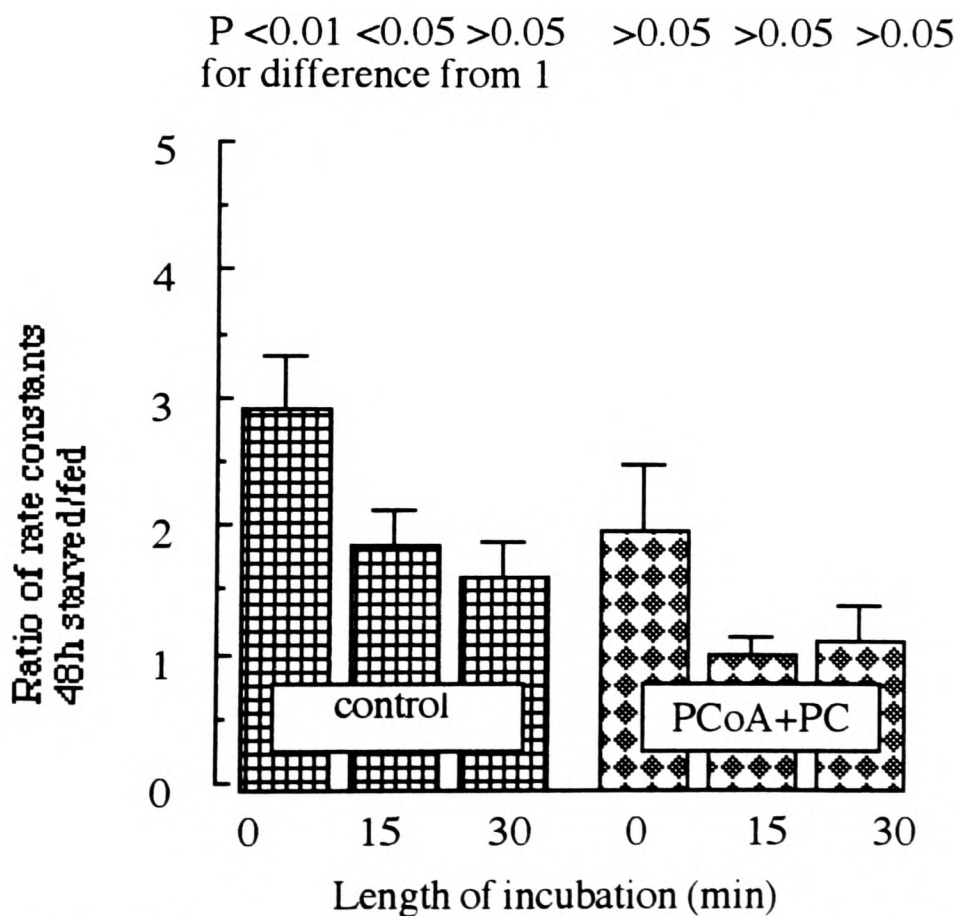
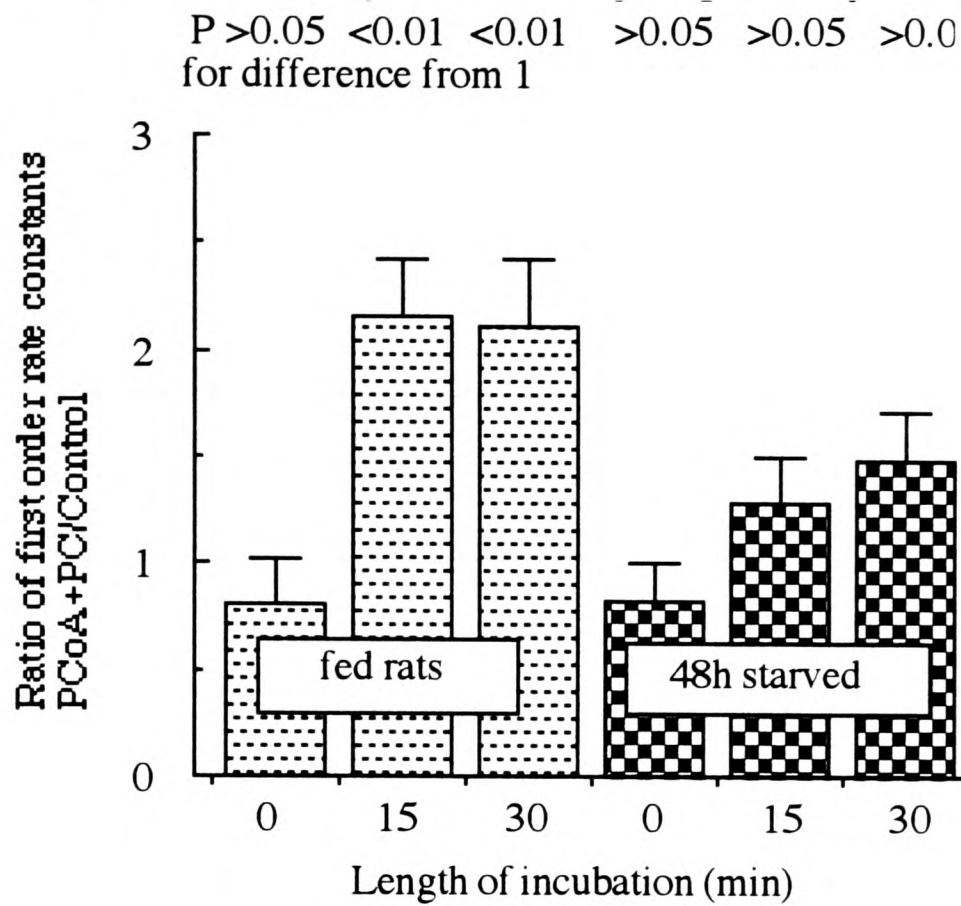

Experimental details are given in the legend to Figure 4.6. Data are expressed as ratios of first order rate constants for PDH kinase activities. 'PCoA'=palmitoyl-CoA and 'PC'=palmitoyl carnitine.

15 Effect of palmitoyl-CoA on the PDH kinase activity in extracts prepared from mitochondria incubated \pm palmitoyl L-carnitine

Palmitoyl carnitine produces proportionally comparable increases in PDH kinase activities of mitochondria from fed or 48h starved rats (chapter 3). It has been shown in the preceding section (14) that incubation with palmitoyl-CoA + palmitoyl carnitine increases the PDH kinase activity in extracts prepared from heart mitochondria of fed rats to that observed in extracts prepared from heart mitochondria of starved rats. In extracts of heart mitochondria from starved rats palmitoyl-CoA + palmitoyl carnitine maintained but did not increase further the PDH kinase activity. This suggested the possibility that the effect of palmitoyl-CoA to increase PDH kinase activity in extracts differed in some way from the effect of palmitoyl carnitine in whole mitochondria. It was important to determine whether palmitoyl-CoA increased PDH kinase in heart mitochondria incubated with extracts prepared from palmitoyl carnitine incubated mitochondria. The data (shown in Figure 4.8) show that PDH kinase activity is increased by incubation with palmitoyl-CoA of extracts prepared from mitochondria that had been incubated with or without palmitoyl carnitine. The increases were 1.8-fold and 2.8-fold respectively for mitochondria with and without palmitoyl carnitine. The persistence of the effect of palmitoyl-CoA in extracts of mitochondria in which PDH kinase activity had already been increased suggests that the mechanism of the two effects may be different. It also suggests the interesting possibility that the effect of palmitoyl-CoA in extracts, but not that of palmitoyl carnitine in intact mitochondria may have features in common with the effect of starvation.

As shown in chapter 3, the effect of palmitoyl carnitine to increase PDH kinase activity in intact mitochondria is not modified by starvation (there is further activation of kinase with incubation of isolated mitochondria from 48h starved rats with palmitoyl carnitine), whereas that of palmitoyl-CoA extracts is decreased or abolished (preceding section of this chapter).

Figure 4.8 Mitochondria first incubated with 50 μ M-palmitoyl-carnitine, 0.5mM-malate and 0.1%-fatty acid free BSA, then extracted and extracts incubated with 50 μ M-palmitoyl-CoA and 50 μ M-palmitoyl-carnitine

Mitochondria were depleted of endogenous substrate by preincubation at approx. 1000mU-PDH complex/ml with KCl medium (120mM-KCl/20mM-tris/5mM-EGTA/5mM-KH₂PO₄ pH 7.4) swirling gently every 20s 30°C. PDH complex activity was measured in an extracted sample (see below). Mitochondria were diluted to 200mU-PDH complex/ml with KCl medium containing 50 μ M-palmitoyl-carnitine/0.5mM-malate/0.1% fatty acid free BSA, for 15min at 30°C swirling every 5min to aerate the mitochondria. Palmitoyl-carnitine incubated mitochondria were centrifuged (MSE 18; 9 000g, 7min, 4°C) and supernatants were decanted and discarded. Pellets were resuspended and incubated in KCl medium/10 μ M-CCCP for 30min at 30°C swirling gently every 5min. Following this incubation mitochondria, as were control mitochondria (only preincubated), were aliquoted into cryotubes, centrifuged (Eppendorf centrifuge; 13 000g, 30s, room temperature). Supernatants were aspirated (hypodermic needle and vacuum) and pellets frozen in liquid nitrogen. Pellets were thawed and resuspended in extraction buffer (50mM-KH₂PO₄/10mM-EGTA/2mM-DTT/1mM-MgCl₂/0.5mM-TLCK/1mM-benzamidine/10 μ M-leupeptin, pH 7.0) and frozen and thawed twice more.

Extracts were then thawed, combined to contain sufficient PDH complex for two runs and incubated with extraction buffer containing 1mM-palmitoyl-CoA and 0.5mM-palmitoyl-carnitine (one run) or extraction buffer alone (the other, control run) for up to 30min. Samples were taken and PDH kinase activities were measured. 10mM-ATP was added to these assays at 0, 10, 15 and 30min. Final concentrations in kinase assays were 300mU-PDH complex/ml, 0.5mM-ATP, 50 μ M-palmitoyl-CoA and 50 μ M-palmitoyl-carnitine.

Data represent means \pm SEMs of individual kinase activities from 3 experiments or 3 mitochondrial preparations and incubations. §=P<0.001 and † = P<0.01 Subscripts denote comparison and these are 1 = extracts of palmitoyl-carnitine incubated mitochondria, incubated with 50 μ M-palmitoyl-CoA and 50 μ M-palmitoyl-carnitine versus control, 2 = extracts of no substrate incubated mitochondria, incubated with 50 μ M-palmitoyl-CoA and 50 μ M-palmitoyl-carnitine versus control, 3 = 50 μ M-palmitoyl-CoA and 50 μ M-palmitoyl-carnitine incubated extracts from palmitoyl-carnitine versus no substrate incubated mitochondria, 4 = control versus control incubated extracts from both incubations of mitochondria, and 5 = activity at 10min for each condition with activity at 0min for that condition.

Figure 4.8 PDH kinase activities with $50\mu\text{M}$ -palmitoyl-CoA+ $50\mu\text{M}$ -palmitoyl-L-carnitine incubated extracts of mitochondria previously incubated with $50\mu\text{M}$ -palmitoyl-L-carnitine, 0.5mM -L-malate and 0.1% -fatty acid free-BSA or incubated without substrate

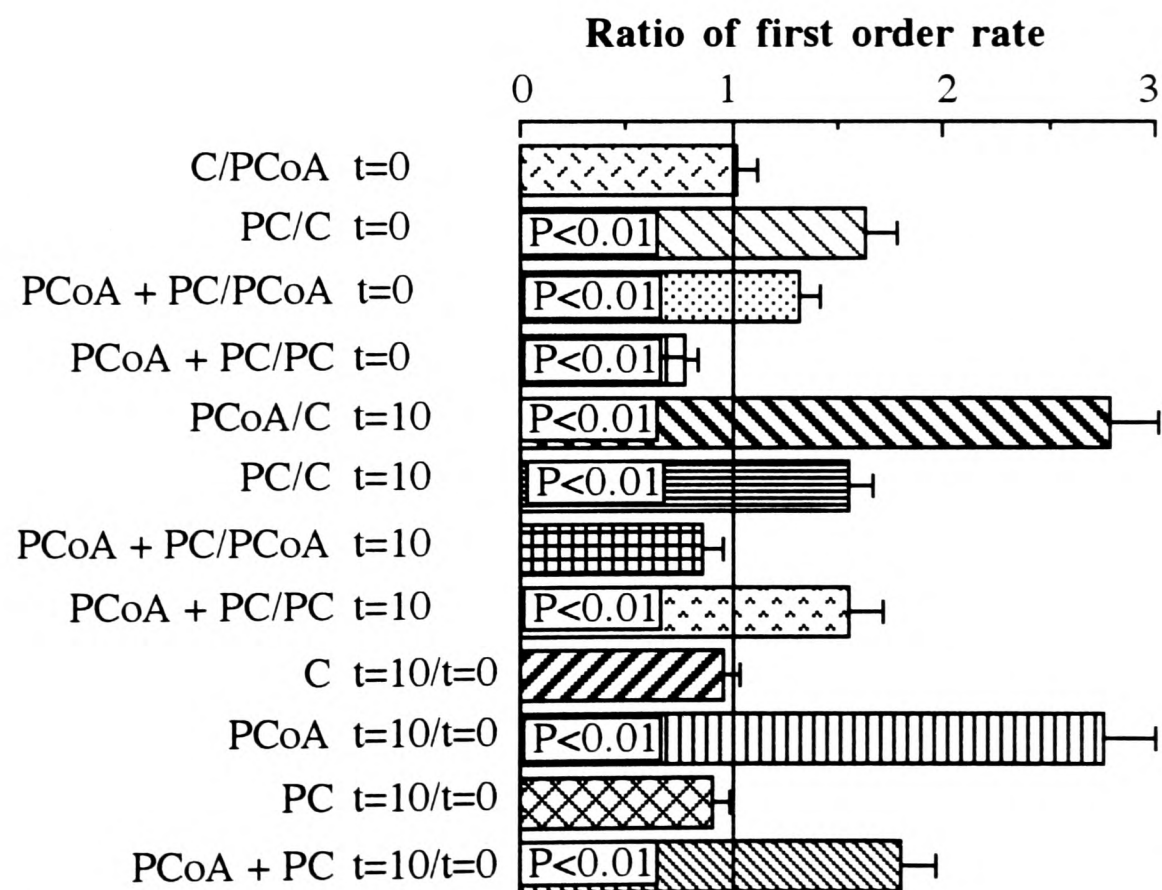
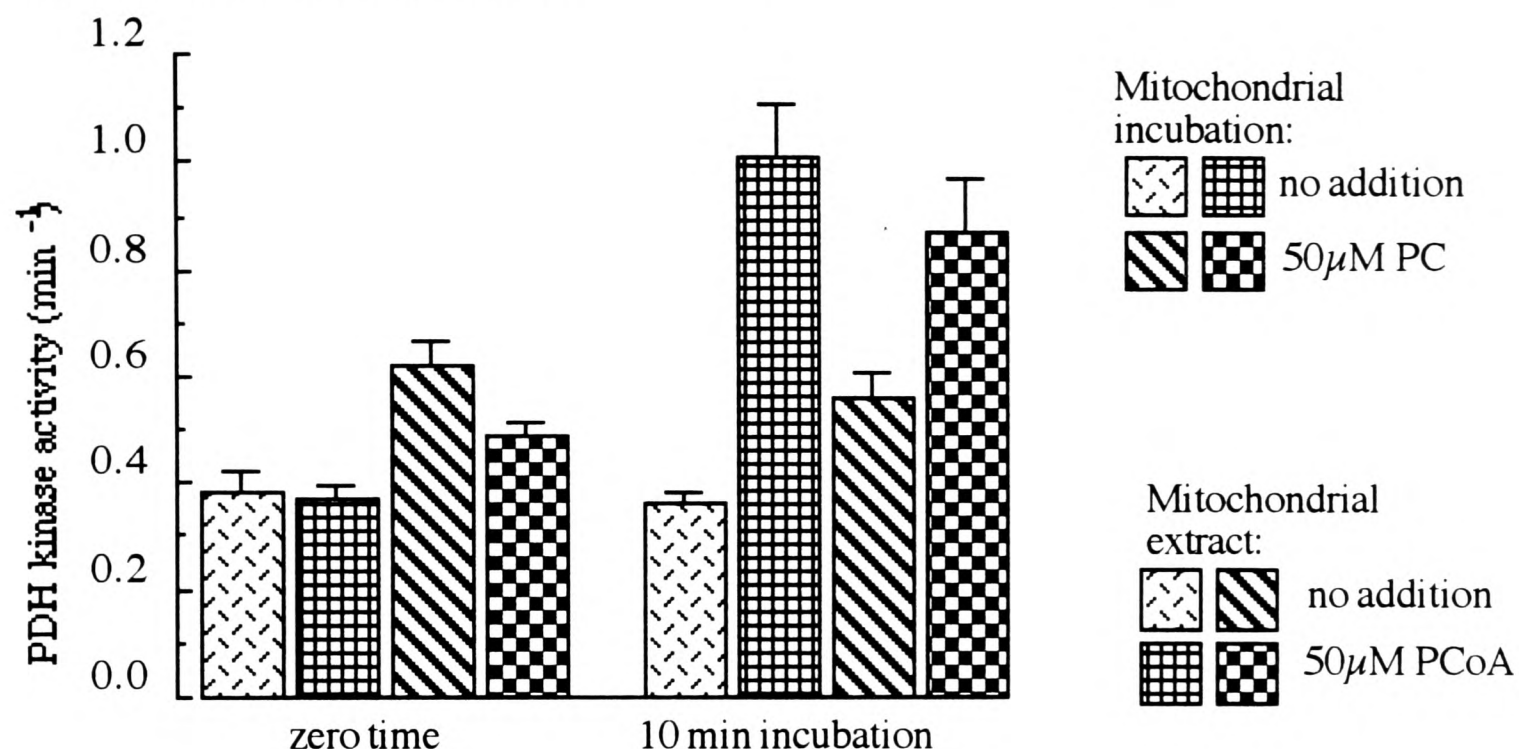

'C'= no substrate incubated mitochondria and control incubated extract; 'PC'=palmitoyl carnitine incubated mitochondria and control incubated extracts; 'PCoA + PC'= palmitoyl carnitine incubated mitochondria + palmitoyl-CoA and palmitoyl carnitine incubated extracts; and 'PCoA'=no substrate incubated mitochondria and palmitoyl-CoA and palmitoyl carnitine incubated extracts; 't'=min incubation of extract.

CONCLUSIONS

Rates of ATP-dependent inactivation of PDH complex, measured in extracts of isolated mitochondria incubated with palmitoyl-CoA were greater than with control mitochondrial extracts incubated in extraction medium alone. Mitochondria had been depleted of endogenous substrates by preincubation (see Kerbey *et al.*, 1976 and previous chapter) and PDH kinase activities were stable throughout extract incubation (up to 60min) without substrate. Addition of palmitoyl carnitine to palmitoyl-CoA incubations may have sustained the palmitoyl-CoA concentration as the palmitoyl-CoA effect was prolonged in its presence. Activation of kinase activity was maximal at 10min as the palmitoyl-CoA was utilised. The time course for maximum activation is comparable with palmitoyl carnitine activation of PDH kinase in incubations with intact mitochondria (see preceding chapter). The time course for the palmitate effect to increase PDH kinase activities with cultured cardiac myocytes is hours (Marchington *et al.*, 1990).

Incubation of extracts of mitochondria from fed rats increases the rates of ATP-dependent inactivation to levels seen with extracts of mitochondria from 48h starved rats. Similar stimulation of PDH kinase activities to starvation levels have been found with incubation of cultured cardiac myocytes with palmitate (Marchington *et al.*, 1990) and with intact mitochondria incubated with palmitoyl carnitine (preceding chapter). Palmitoyl-CoA has no effect in mitochondrial extracts from starved rats except possibly to maintain high levels of PDH kinase activity that would have decreased by incubation in its absence. Starvation induced increases have been maintained in soleus muscle culture by palmitate (Stace *et al.*, 1992) and in cultured hepatocytes with palmitate (Marchington *et al.*, 1989). These results suggest that the mechanism of the effect of mitochondrial extract incubation with palmitoyl-CoA on rates of ATP-dependent inactivation of complex may be similar to that to induce rates *in vivo* by starvation and possibly by diabetes as the concentration of acyl-CoA is increased in hearts of rats under these conditions (Garland and Randle, 1964b).

The palmitoyl-CoA effect in mitochondrial extracts and the palmitoyl carnitine effect in whole mitochondria are unlikely to be the same as palmitoyl-CoA further stimulates the PDH kinase activity already increased by palmitoyl carnitine incubation of intact mitochondria and

because palmitoyl carnitine in intact mitochondria further enhances the activation effected by starvation.

In chapter 3 and this chapter PDH kinase activity was measured as the initial rate of ATP-dependent inactivation of PDH complex and are expressed as first order rate constants. Initial rates of inactivation have been correlated with initial rates of incorporation of phosphate (*e.g.* Hutson and Randle, 1978) which is mainly incorporation into site 1 of the α -chain of the E1 component of the complex and thus gives a measure of PDH kinase activity. It was important to determine whether the *in vitro* effects of palmitoyl carnitine in mitochondria and palmitoyl-CoA in mitochondrial extracts to accelerate ATP-dependent inactivation also accelerate phosphorylation and this is the basis of the experiments presented in chapter 5.

Chapter 5

**Effect of palmitoyl carnitine on incorporation of ^{32}P from $[\gamma\text{-}^{32}\text{P}]$
ATP into PDH complex in extracts of rat heart mitochondria**

INDEX

	Page
Introduction	5.3
Materials and Methods	5.6
1 Materials	5.6
2 Solutions	5.6
3 Preparation and processing of paper squares	5.7
4 Measurement of the specific activity of 10mM- $[\gamma\text{-}^{32}\text{P}]\text{ATP}$	5.7
5 Rats	5.7
6 Preparation of rat heart mitochondria	5.8
7 Mitochondrial incubations	5.8
8 Assay of pyruvate dehydrogenase (PDH) complex activity	5.9
9 Assay of PDH kinase activity by the rate of ATP-dependent inactivation of PDH complex	5.9
10. Assay of PDH kinase activity by the rate of incorporation of ^{32}P from $[\gamma\text{-}^{32}\text{P}]\text{ATP}$ into PDH complex	5.9
11 Assay of PDH phosphatase activity by the rate of reactivation of phosphorylated PDH complex	5.11
12 Assay of PDH phosphatase activity by the rate of $^{32}\text{P}_i$ release from $[\text{}^{32}\text{P}]\text{-phosphorylated PDH complex}$	5.11
13 Definition of enzyme activity	5.12
14 Expression of results and statistical analysis	5.12
Results and Discussion	5.13
15 Effect of palmitoyl carnitine incubation of heart mitochondria, on PDH kinase activity measured in mitochondrial extracts by rates of ATP-dependent inactivation of, and by incorporation of ^{32}P from $[\gamma\text{-}^{32}\text{P}]\text{ATP}$ into PDH complex	5.13
16 Effect of incubation of rat heart mitochondrial extracts with palmitoyl-CoA (plus palmitoyl carnitine) on PDH kinase activities as measured by rates of ATP-dependent inactivation and incorporation of ^{32}P from $[\gamma\text{-}^{32}\text{P}]\text{ATP}$ into PDH complex	5.17
17 Effect of non-phosphorylating analogue of ATP on the rate of inactivation of PDH complex with extracts of mitochondria previously incubated with palmitoyl carnitine	5.18
18 Effects of known PDH kinase inhibitors on the rate of ATP-dependent inactivation of PDH complex in extracts of mitochondria previously incubated with palmitoyl carnitine	5.19
19 Effect of incubation of heart mitochondria, prepared from fed and 48h starved rats, in the presence of palmitoyl carnitine on rates of reactivation and of release of $^{32}\text{P}_i$ from $[\text{}^{32}\text{P}]\text{-phosphorylated PDH complex}$	5.21
20 Effect of PDH phosphatase inhibitors on the rate of reactivation of phosphorylated PDH complex in extracts of mitochondria previously incubated \pm palmitoyl carnitine	5.23
Conclusions	5.25

INTRODUCTION

The PDH complex of animal tissues is inactivated by phosphorylation of the decarboxylase (E1) component, which has the subunit structure $\alpha_2\beta_2$. The α subunit contains 3 sites for phosphorylation on three serine residues. Trypsin and formic acid cleavages of the α subunit produce three peptides each containing one phosphorylation site. Separation of individual phosphorylation sites has allowed studies to be made to determine the role of each site in regulating the activity of the holocomplex. (For further details see general introduction.) In rat heart *in vivo* and in rat heart mitochondria rates of incorporation of phosphate into sites follow the pattern site 1 faster > site 2 > site 3 (Sale and Randle, 1980; Sale and Randle, 1982b). Phosphorylation of site 1 is the major site of inactivation and occupancy of this site is linearly correlated with the proportion of inactive complex. Phosphorylation of site 2 has a minor role in inactivating PDH complex and phosphorylation of site 3 is not-activating (Yeaman *et al.*, 1978; Sugden *et al.*, 1979; Hughes *et al.*, 1980; Sale and Randle, 1982). There is evidence that phosphorylation of either site 1 or site 2 inactivates purified PDH complex (Teague *et al.*, 1979; Radcliffe *et al.*, 1980; Tonks *et al.*, 1982). Evidence that site 2 phosphorylation is inactivating is based upon the observation that pig heart complex thiophosphorylated in sites 2 and 3 with ATP γ S but with site 1 empty is inactive (Tonks *et al.*, 1982). The contribution of site 2 to inactivation of the complex is small (<2%) during phosphorylation of purified complex, or of complex in rat heart mitochondria and <1% in the steady state in mitochondria (Sale and Randle 1981, 1982a). In mitochondria in the steady state, phosphorylation of sites 2 and 3 is minimal (relative to site 1) when the proportion of inactive complex is 70% or less (as found with mitochondria from fed rat). Occupancy of sites 2 and 3 only approach equivalency with occupancy of site 1 when PDH complex is >99% inactive as in mitochondria from 48h starved or alloxan-diabetic rats (Sale and Randle, 1980, 1982a; 1982b). The enhanced phosphorylation and degree of inactivation of PDH complex in hearts of starved and alloxan diabetic rats is presumed to result from an increased activity ratio of PDH kinase relative to that of PDH phosphatase - the result mainly of increased PDH kinase

activity (Hutson and Randle, 1978; Fatania *et al.*, 1986; Denyer *et al.*, 1986; Marchington *et al.*, 1990; Priestman *et al.*, 1994).

In the previous two chapters it was been clearly demonstrated that incubation of isolated rat heart mitochondria with palmitoyl carnitine or succinate or α -ketoglutarate or α -ketoisocaproate (and to a lesser extent with acetyl carnitine) results in a stable increase in PDH kinase activity (this effect persists when mitochondria are depleted of respiratory substrate by incubation with uncouplers of respiratory chain phosphorylation and repeated freezing and thawing). Incubation of extracts of mitochondria with palmitoyl-CoA also resulted in increased kinase PDH activity. The method used to assay PDH kinase activity in these studies involved measurement of the initial rate of ATP dependent inactivation of PDH complex. Initial rates of ATP dependent inactivation are correlated with initial rates of phosphorylation in the PDH complex, when inactivation is the result of phosphorylation. Thus, for example, the effect of starvation is an increase the rate of ATP dependent inactivation of PDH complex is associated with a parallel increase in the rate of phosphorylation of the complex (Hutson & Randle, 1978). It was important to determine whether the *in vitro* effects of palmitoyl carnitine in mitochondria and of palmitoyl CoA in mitochondrial extracts to accelerate ATP-dependent inactivation are associated with accelerated phosphorylation.

In this chapter phosphorylation of PDH complex was studied by the rate of incorporation of ^{32}P from $[\gamma\text{-}^{32}\text{P}]\text{ATP}$ into the complex as measured by the paper squares method of Corbin and Reiman (1974). Rates of incorporation of ^{32}P into proteins (predominantly PDH complex) were measured in extracts prepared from mitochondria that had been incubated \pm palmitoyl-carnitine, or without substrate; and in mitochondrial extracts incubated in the presence or absence of palmitoyl-CoA. Following incubation with $[\gamma\text{-}^{32}\text{P}]\text{ATP}$ the amount of radioactivity - precipitated onto paper squares with trichloroacetic was assayed by scintillation counting.

Based upon the known effects of starvation and alloxan-diabetes (Hutson & Randle, 1978) the results expected from the experiments presented in this chapter were that the effects of palmitoyl-carnitine in mitochondria and of palmitoyl-CoA on mitochondrial extracts would lead to parallel increases in rates of inactivation of PDH complex and of incorporation of phosphate.

However the results of incorporation of ^{32}P into PDH complex showed unexpectedly that the enhanced rate of ATP dependent inactivation was not associated with a corresponding increase in the rate of ^{32}P incorporation. These interesting results necessitated further studies designed to determine whether the enhanced rate of inactivation was indeed due to phosphorylation. Evidence presented here indicates that palmitoyl-carnitine induced increases in rates of inactivation were due to phosphorylation notwithstanding that the overall rate of phosphorylation was not increased.

MATERIALS AND METHODS

1 Materials

Sources of chemicals and biochemicals were as in section 1 of chapter 3, with the following additions. 5'-Adenylylimidodiphosphate (β, γ -imidoadenosine 5'-triphosphate: App[NH]p; AMP-PNP) (lithium salt) (AMP-PNP), TCA and 1mM-CaCl₂ aqueous solution were from Sigma Chemical Co. Ltd., Fancy Road, Poole, Dorset, UK. Diethyl ether, P₂O₅ and NaF were from BDH Chemicals Ltd., Poole, Dorset, UK. Absolute ethanol was from Hayman Ltd Witham, Essex; [γ -³²P]ATP was delivered frozen in 125 μ l of 50% aqueous ethanol by Amersham, Amersham Place, Little Chalfont, Bucks., U.K. Opti-fluor[®] (high flash-point liquid scintillation cocktail for aqueous and nonaqueous samples was supplied by Packard Instrument Co Inc, 2200 Warrenville Road, Downers Grove, Illinois, USA. Whatman 3MM paper was from Whatman Ltd, Springfield Mill, Maidstone, Kent, UK.

2 Solutions

Solutions were prepared as described in the previous chapter, with the following additions. PDH phosphatase assay buffer (0.1mM-Tris-HCl/2.5mM-CaCl₂/125mM-MgCl₂/5mM-EDTA), was adjusted to pH 8.4 and stored at 4°C. Stock solutions of PDH kinase inhibitors 12mM-ADP and 6mM-pyruvate, 1mM-TPP were made in extraction buffer (50mM-KH₂PO₄/10mM-EGTA/2mM-DTT/1mM-MgCl₂/0.5mM-TLCK/1mM-benzamidine/10 μ M-leupeptin, pH 7.0 containing 50 μ g-oligomycin B/ml) on the day of use. The stock solutions of 10mM-AMP-PNP (gravimetric measurement) and 10mM-ATP were made and the concentrations measured spectrophotometrically (see section 3 of chapter 3).

Preparation of 10mM- $[\gamma$ -³²P] ATP stock solution. Stock [γ -³²P]ATP is supplied dissolved in a 50% aqueous ethanol solution and was removed prior to use as follows. The solution was thawed at room temperature, transferred to an eppendorf tube with a pierced lid, placed in a desiccator over a petri dish containing P₂O₅ and freeze dried using a Unitrap II lyophiliser from Virtis Gardiner, New York, USA. The residue was redissolved in 10mM-ATP

(whirlimixer) and its specific activity measured (see section 4).

3 Preparation and processing of paper squares

Preparation. Paper squares were from Whatman 3MM paper, soaked in 5mM-ATP/1mM-MgCl₂ solution and dried at room temperature. When dry the paper was cut into squares 2 x 2 cm. Impregnating the paper with ATP this way minimises free binding of [γ -³²P]ATP. Heating the paper above room temperature to dry it more quickly scorches the paper and as carbon adsorbs ATP would lead to high background radioactivity.

Processing. Paper squares were further processed as follows. Paper squares were washed in continuously stirred 10%-TCA for 15min, then in fresh 10%-TCA for 20min (x3), dehydrated with 95% ethanol for 15min, and finally with diethyl ether for 10min. Each washing solution was kept ice cold. Paper squares were dried in stream of warm air (hair dryer), placed in scintillation vials containing scintillant Optifluor[®] and the radioactivity determined using an LKB 1214 Rackbeta Liquid Scintillation counter controlled by computer. Paper squares do not quench ³²P (Sugden and Randle, 1978).

4 Measurement of the specific activity of 10mM- $[\gamma$ -³²P]ATP

5 μ l of 10mM- $[\gamma$ -³²P]ATP solution (made as described above 2 solutions) was transferred to a quartz cuvette containing 1N-HCl. The concentration was measured at 257nm (deuterium lamp) using a spectrophotometer and calculated from the mM extinction coefficient for ATP of 14.4cm⁻¹. 5 μ l samples of the cuvette contents (ATP HCl solution) were transferred to scintillation vials containing scintillant and the radioactivity counted. The specific activity was calculated from these measurements. Specific activities were on average 400 dpm/pmol.

5 Rats

Male albino Wistar rats were used weighing greater than 300g. Details of maintenance and diet are described in section 6 of chapter 3.

6 Preparation of rat heart mitochondria

Rat heart mitochondria were prepared by the method described by Kerbey *et al.* (1976) as fully described in section 4 of chapter 4.

Isolated mitochondria in KCl incubation buffer (120mM-KCl/20mM-Tris/5mM-EGTA/5mM-KH₂PO₄, pH 7.4) were pre-incubated (10min, 30°C, aeration by swirling the tube gently every 20s) to deplete mitochondria of endogenous substrate and to effect conversion of inactive (phospho) PDH complex to active (dephospho) complex.

The purity of the mitochondrial preparation was assessed by measuring the specific activity of PDH complex (mU/mg protein). A sample of 25µl of mitochondria was added to 75µl extraction buffer (50mM-KH₂PO₄/10mM-EGTA/2mM-DTT/1mM-MgCl₂/0.5mM-TLCK/1mM-benzamidine/10µM-leupeptin, pH 7.0) and rapidly frozen in liquid nitrogen and thawed a total of three times. PDH complex activity (see section 10 of chapter 3) and protein concentration (Gornall, *et al.*, 1949) were measured. Mitochondrial preparations generally had specific activities of approx. 100mU-PDH complex activity /mg mitochondrial protein.

7 Mitochondrial incubations

Mitochondria were incubated at 200mU-PDH complex/ml in prewarmed KCl incubation buffer (120mM-KCl/20mM-Tris/5mM-EGTA/5mM-KH₂PO₄, pH 7.4) containing 50µM-palmitoyl-carnitine, 0.1%-fatty acid free BSA and 0.5mM-malate or incubated in KCl incubation buffer alone for 15min at 30°C (stirring water bath). During the incubation sample tubes were aerated by gently swirling every 5min.

Activation of PDH complex. Following incubation of rat heart mitochondria described above mitochondria were separated from incubation media by centrifugation (MSE 18; 8 x 50 ml fixed angle rotor at 10 000 g for 8min at 4°C). Supernatants were decanted and discarded. The mitochondrial pellet was resuspended (mini glass rod see section 7 of chapter 3) gradually in KCl medium/10µM-CCCP to 1ml and diluted to approximately 2mg protein/ml and incubated at 30°C for 30min and the tubes gently swirled every 5min. Following CCCP incubation 1ml samples

were aliquoted into cryotubes, and rapidly centrifuged (Eppendorf centrifuge 13 000g for 30s at room temperature), supernatants aspirated using a hypodermic needle and vacuum, and the pellets immediately frozen in and stored in liquid nitrogen.

Preparation of mitochondrial extracts. Mitochondrial pellets were thawed into 50 μ l or 100 μ l extraction buffer (50mM-KH₂PO₄/10mM-EGTA/2mM-DTT/1mM-MgCl₂/0.5mM-TLCK/1mM-benzamidine/10 μ M-leupeptin, pH 7.0 containing oligomycin B 50 μ g/ml) at 30°C (water bath) and dispersed by repeated aspiration and ejection with a 100 μ l Hamilton syringe. Extraction was completed by further freezing and thawing (*i.e.* twice more). The extracts were stored in liquid N₂ after the final freeze until used for assay.

8 Assay of pyruvate dehydrogenase (PDH) complex activity

The activity of PDH complex was measured spectrophotometrically using the method described in section 10 of chapter 3.

9 Assay of PDH kinase activity by the rate of ATP-dependent inactivation of PDH complex

Rat heart PDH kinase activity was measured in extracts of incubated mitochondria (see section 7). The PDH kinase assay method is given in section 11 of chapter 3.

In experiments where PDH kinase inhibitors were used, inhibitor solution was added to the kinase assay mix so that the concentration of PDH complex after addition of 10mM-ATP was 300mU-PDH complex/ml and final concentrations in the solution were 0.5mM-ATP and 1.42mM-ADP, 0.95mM-pyruvate, or 20 μ M-TPP.

10 Assay of PDH kinase activity by the rate of incorporation of ³²P from [γ -³²P] ATP into PDH complex

In this assay PDH kinase activity was measured by the rate of incorporation of ³²P from [γ -³²P]ATP into PDH complex in extracts of incubated mitochondria

The method used to measure protein bound ^{32}P was as described by Corbin and Reiman (1974) and involves the measurement of radiolabelled protein after precipitation onto paper squares with TCA (see section 3). The assay conditions were as described for the ATP dependent inactivation assay except that extracts were incubated with 10mM- $[\gamma\text{-}^{32}\text{P}]\text{ATP}$ (see section 2) and samples pipetted onto paper squares at 20, 40 and 60s after the addition of ATP. The paper squares were further processed and counted according to section 3. Rates of ATP dependent inactivation were measured in parallel incubations with non-radioactive ATP as described previously. ^{32}P -

Phosphorylation can be expressed as a rate, *i.e.* nmol of ^{32}P incorporated per unit of PDH complex per min or as nmol of ^{32}P incorporated per unit of PDH complex inactivated per min.

The kinetics of phosphorylation of PDH complex are more complicated than those of ATP dependent inactivation. Inactivation depends essentially on the rate of phosphorylation of a single site (essentially site 1) and the end result is essentially complete inactivation (>99per cent). ^{32}P -Phosphorylation always involves some incorporation into site 2 (and to a lesser extent into site 3), the three sites have different rate constants (sites 1>2>3) and it is impractical to achieve complete phosphorylation of all sites in mitochondrial extracts as a matter of routine. The only other mitochondrial protein kinase that might interfere is the branched chain ketoacid dehydrogenase kinase, but total branched chain ketoacid dehydrogenase complex activity in heart is no more than approximately 5 per cent of that of PDH complex (Patston *et al.*, 1986). Blanks were incorporated routinely to correct for non-specific binding of $[\gamma\text{-}^{32}\text{P}]\text{ATP}$ to paper squares and were performed in one of two ways. An incorporation assay mix containing extracts was made as described above and kept on ice. 10mM- $[\gamma\text{-}^{32}\text{P}]\text{ATP}$ was added to a final concentration of 0.5mM, mixed by vortex and an aliquot of equal volume to the assay sample was immediately pipetted onto a paper square. Each blank was taken from one assay mix. An alternative method employed assay mix as above supplemented with the PDH kinase inhibitors TPP and ADP added to final concentrations of 20 μM and 1.42mM respectively, the assay was mixed by vortex and kept on ice. 10mM- $[\gamma\text{-}^{32}\text{P}]\text{ATP}$ was added to a final concentration of 0.5mM, mixed by vortex and aliquots of equal volume as in sample assay were pipetted onto paper squares as quickly as possible.

11 Assay of PDH phosphatase activity by the rate of reactivation of phosphorylated PDH complex

Rat heart PDH phosphatase activity was measured in extracts of incubated mitochondria (see section 7) by the rate of reactivation of phosphorylated PDH complex. Extracts were diluted to 2U-PDH complex/ml with extraction buffer (50mM-KH₂PO₄/10mM-EGTA/2mM-DTT/1mM-MgCl₂/0.5mM-TLCK/1mM-benzamidine/10μM-leupeptin, pH 7.0). Extracts were divided equally between two fresh eppendorfs. 10mM-ATP (final concentration 1mM) was added to one eppendorf and, for control assays, an equal volume of water was added to the other. Both extract mixes were incubated at 30°C for the length of time required (with ATP present) to effect 90% inactivation of PDH complex. (The period of incubation needed to effect 90% inactivation with ATP was determined from the rate of ATP dependent inactivation measured in these extracts. These were 1) 4min for extracts from fed no substrate incubated mitochondria, 2) 2min for those from starved no substrate or fed palmitoyl carnitine incubated mitochondria, and 3) 1min for those from starved palmitoyl carnitine incubated mitochondria. These conditions allowed PDH kinase activity to predominate. The assay conditions were altered by the addition of PDH phosphatase assay buffer (0.1M-Tris-HCl/2.5mM-CaCl₂/125mM-MgCl₂/5mM-EDTA, pH 8.4) and PDH kinase inhibitors ADP and pyruvate were added to final concentrations of 1.42mM and 0.95mM respectively. Incubation was at 30°C for up to 65min. The rate of reactivation of PDH complex was measured by assaying PDH complex activity in samples taken periodically during the incubation.

The PDH complex activities measured in blank runs (H₂O in place of ATP) showed a loss of up to 20% of activity and this loss was taken account of in calculating reactivation of PDH complex in assays containing ATP.

12 Assay of PDH phosphatase activity by the rate of ³²P_i release from [³²P]-phosphorylated PDH complex

Rat heart PDH phosphatase activity was measured in extracts of incubated mitochondria (see section 7). PDH phosphatase activity was determined by the rate of release of ³²P from ³²P

phosphorylated PDH complex using the paper squares method of Corbin and Reiman (1974) (see section 11) except for the following. The solution of ATP used in the initial measurement of PDH kinase activity was as above but the ATP solution used in the PDH phosphatase assay contained $[\gamma\text{-}^{32}\text{P}]\text{ATP}$. (See section 2 for preparation of 10mM- $[\gamma\text{-}^{32}\text{P}]\text{ATP}$). Rates of reactivation of PDH complex activity and of release of $^{32}\text{P}_i$ from $[\text{}^{32}\text{P}]$ -phosphorylated complex were made simultaneously in experiments involving $[\text{}^{32}\text{P}]$ -phosphorylated complex. For ^{32}P incorporation samples taken at intervals, after the addition of PDH phosphatase assay buffer and PDH kinase inhibitors, were added to paper squares (see section 3) or to cuvettes containing PDH complex assay reagents (see section 11 of chapter 3). Blanks were performed using the same extracts except that the whole procedure was carried out on ice. Extracts were diluted to 2U-PDH complex/ml with ice-cold extraction buffer. PDH phosphatase assay buffer and kinase inhibitors were added immediately after adding 10mM- $[\gamma\text{-}^{32}\text{P}]\text{ATP}$ and samples were pipetted onto paper squares.

13 Definition of enzyme activity

1 Unit of enzyme activity is defined as the amount required to convert 1 μmol of substrate to product in 1min at 30°C.

14 Expression of results and statistical analysis

Data are expressed as means \pm SEM together with the number of assays or the number of experiments (mitochondrial preparations) given in parentheses. The results of identical experiments with different preparations were combined. The significance of differences between means was established by t-test.

RESULTS AND DISCUSSION

15 Effect of palmitoyl carnitine incubation of heart mitochondria, on PDH kinase activity measured in mitochondrial extracts by rates of ATP-dependent inactivation of, and by incorporation of ^{32}P from $[\gamma\text{-}^{32}\text{P}]\text{ATP}$ into PDH complex.

Rates of incorporation of ^{32}P from $[\gamma\text{-}^{32}\text{P}]\text{ATP}$ into PDH complex in extracts prepared from heart mitochondria of fed rats incubated in KCl medium were not significantly influenced by inclusion of $50\mu\text{M}$ palmitoyl-L-carnitine/ 0.5mM -L-malate (Table 5.1; Fig 5.1). In parallel assays, rates of inactivation were also measured, and these were 2.5-fold greater with extracts from mitochondria incubated with palmitoyl carnitine than with control extracts ($P < 0.001$). Moreover under the conditions used (maximum incubation time 1 min); $t_{0.5}$ for inactivation were control 1.9min and PC 0.8min. Inactivations were thus within the range of 0 to 70 per cent over which range phosphate incorporation is mainly (>85 per cent) into site 1.

Thus the effect of palmitoyl carnitine incubation to increase the rate of ATP dependent inactivation of PDH complex in extracts of heart mitochondria was not associated with a corresponding increase in the rate of incorporation of ^{32}P from $[\gamma\text{-}^{32}\text{P}]\text{ATP}$ into PDH complex. Incubation with palmitoyl carnitine thus approximately halved the incorporation of phosphate associated with inactivation of the complex. The likely significance of this finding is discussed later.

Starvation of rats for 48h produced the expected increases in both the rate of ATP dependent inactivation and the rate of incorporation of ^{32}P from $[\gamma\text{-}^{32}\text{P}]\text{ATP}$ into PDH complex in extracts of heart mitochondria. The increases were 3.2-fold for inactivation (based on rate constants in Table 5.1) and 2.7-fold, 2-fold and 1.8-fold for incorporations at 20, 40, and 60s of incubation with $[\gamma\text{-}^{32}\text{P}]\text{ATP}$ (Table 5.1; Fig. 5.2). These results are comparable with those of Hutson and Randle (1978) who found increases in both rates of ATP dependent inactivation and of incorporation of ^{32}P from $[\gamma\text{-}^{32}\text{P}]\text{ATP}$ into PDH complex with extracts of mitochondria from 48h starved rats.

Table 5.1 Rates of incorporation of ^{32}P from [γ - ^{32}P] ATP into PDH complex and rates of inactivation of complex with extracts prepared from mitochondria previously incubated \pm palmitoyl-L-carnitine.

Exp.	Mitochondria and incubation medium	Rate of inactivation of PDH complex (min^{-1})	Incorporation of ^{32}P into PDH complex (nmol/U-PDHP complex)		
			20s	40s	60s
1, 2	fed (no substrate)	0.36 \pm 0.04(7)	0.14 \pm 0.01(12)	0.24 \pm 0.02(12)	0.33 \pm 0.02(12)
	fed (50 μM -PC/0.5mM-malate)	0.89 \pm 0.08(7) \S 1	0.14 \pm 0.02(12)	0.25 \pm 0.01(12)	0.32 \pm 0.04(12)
3	fed (no substrate)	0.36 \pm 0.02(5)	0.15 \pm 0.02(5)	0.38 \pm 0.01(5)	0.55 \pm 0.02(5)
	48h starved (no substrate)	1.15 \pm 0.06(5) \S 2*4	0.40 \pm 0.02(5) \S 2,4	0.77 \pm 0.04(5) \S 2,4	0.95 \pm 0.02(5) \S 2*4
	48h starved (50 μM -PC /0.5mM-malate)	2.86 \pm 0.13(5) \S 2,3	0.52 \pm 0.03(5) \S 2,*3	0.92 \pm 0.04(5) \S 2,*3	1.10 \pm 0.04(5) \S 2,†3

PC=palmitoyl carnitine. Heart mitochondria were prepared from fed and 48h starved rats, preincubated in KCl medium for 10min at 30°C to deplete mitochondria of endogenous substrates (see section 6). After measuring PDH complex activity in an extracted sampled mitochondria were incubated (200mU-PDH complex/ml) with KCl media with 50 μM -PC/0.1%-fatty acid free BSA/0.5mM-malate or KCl medium alone, for 15min at 30°C, swirling every 5min. Incubations were centrifuged (MSE 18; 10 000g for 7-8min at 4°C). Supernatants were decanted and discarded, and pellets were resuspended and incubated with KCl medium/10 μM -CCCP for 30min at 30°C, swirling every 5min. Following this incubation mitochondria were aliquoted into cryotubes and centrifuged (eppendorf centrifuge; 13 000g for 30s at room temperature). Supernatants were aspirated (hypodermic needle and vacuum) and pellets frozen in liquid N₂. Pellets were thawed and resuspended in extraction buffer (50mM-KH₂PO₄/10mM-EGTA/2mM-DTT/1mM-MgCl₂/0.5mM-TLCK/1mM-benzamide/10 μM -leupeptin, pH 7.0 containing 50 μg -oligomycin B/ml), and frozen and thawed x2.

Rates of incorporation of ^{32}P from [γ - ^{32}P] ATP into PDH complex using paper squares method (see section 10) and rates of ATP dependent inactivation of PDH complex measured (see section 9). Rates of inactivation and rates of incorporation were measured using the same mitochondrial extracts divided into two and both types of assay were performed simultaneously: to one portion [γ - ^{32}P]ATP was added for incorporation assays and to the second portion non-radioactive ATP was added for inactivation assays. The 10mM-[γ - ^{32}P]ATP solution was prepared with the same non-radioactive 10mM-ATP solution added to inactivation assays. (See text for details). Data represent means \pm SEM for the number of observations in parentheses.*P<0.05, †P<0.01, \S P<0.001. The superscript number denotes comparison: 1 PC versus no substrate (exp. 1 and 2); 2 starved PC or starved no substrate versus fed no substrate (exp 3); 3 starved PC versus starved or fed no substrate (exp.3); and 4 fed palmitoyl-carnitine (exp 1 and 2) versus starved no substrate (exp 3).

Figure 5.1 Rates of incorporation of ^{32}P from $[\gamma\text{-}^{32}\text{P}]\text{ATP}$ into PDH complex in extracts of mitochondria previously incubated in media containing palmitoyl carnitine, or medium alone (experiments 1 and 2 of Table 5.1)

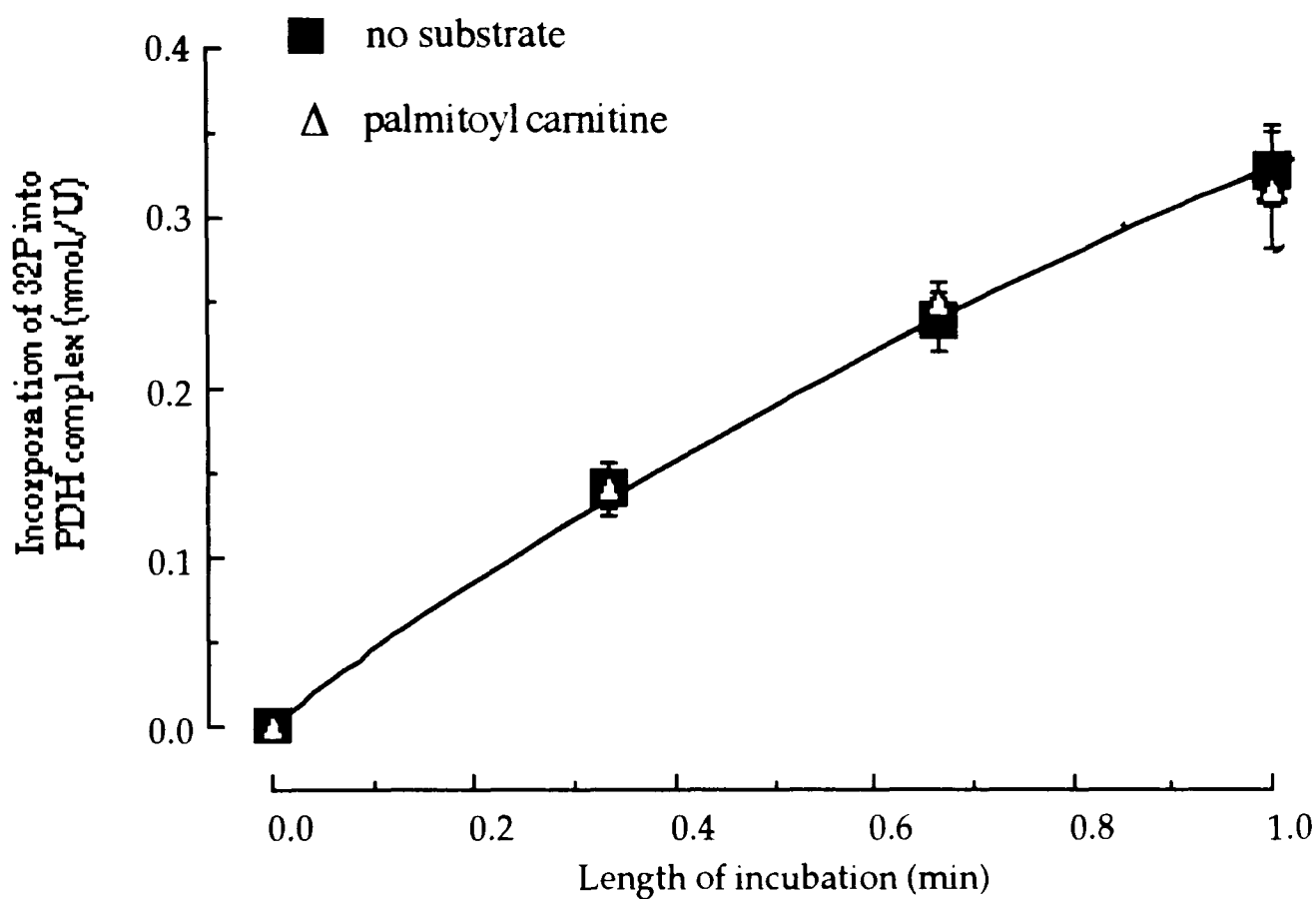

Mitochondria (200mU-PDH complex/ml) were preincubated in KCl medium for 10min at 30°C to deplete mitochondria of endogenous substrates (see section 6). After measuring PDH complex activity in an extracted sampled mitochondria were incubated with KCl medium/50 μM -palmitoyl-L-carnitine/0.1%-fatty acid free BSA/0.5mM-L-malate, or KCl medium alone, for 15min at 30°C and gently swirled every 5 min. Mitochondria were separated from incubation medium by centrifuging (MSE 18; 10 000g for 7-8min at 4°C) and supernatants decanted and discarded. Pellets were resuspended and mitochondrial PDH complex reactivated by incubation with KCl medium/10 μM -CCCP (200mU-PDH complex/ml) for 30min at 30°C. Following this incubation mitochondria were aliquoted into cryotubes tubes and centrifuged (eppendorf centrifuge; 13 000g for 30s at room temperature, supernatants were aspirated (hypodermic needle, vacuum) and discarded and pellets frozen in liquid nitrogen. Pellets were thawed and resuspended at room temperature in 100 μl extraction buffer (50 mM KH_2PO_4 10 mM EGTA/ 2 mM DTT/ 1 mM MgCl_2 / 0.5 mM TLCK/ 1 mM benzamidine/ 10 μM leupeptin at pH 7.0 containing 50 $\mu\text{g}/\text{ml}$ oligomycin B) and then frozen and thawed x2. (Details are given in section 7.) Extracts were incubated with 0.5mM- $[\gamma\text{-}^{32}\text{P}]\text{ATP}$, samples were taken at 20, 40 and 60s (after the addition of ATP) and pipetted onto paper squares (see section 10). Proteins adhering to the paper squares were precipitated by ice-cold 10%-TCA, paper squares were further processed and the radioactivity counted according to section 3. Data represent means \pm SEM for 12 assays.

Figure 5.2 Rates of incorporation of ^{32}P from $[\gamma\text{-}^{32}\text{P}]\text{ATP}$ into PDH complex in extracts of incubated mitochondria prepared from fed and 48h starved rats incubated with and without palmitoyl carnitine (experiment 3 of Table 5.1)

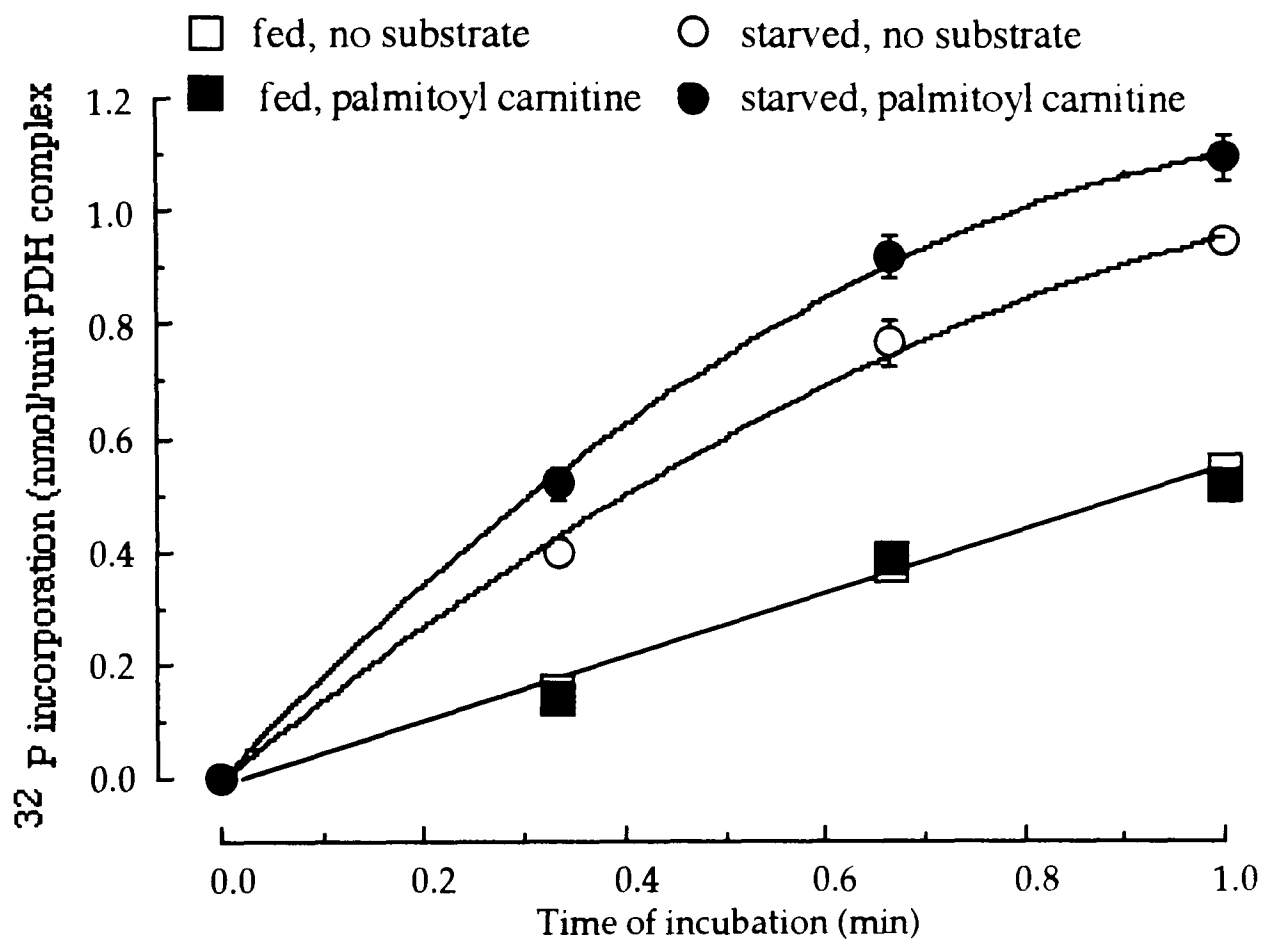

Mitochondria, prepared from fed and 48h starved rats, were preincubated in KCl medium for 10min at 30°C to deplete mitochondria of endogenous substrates. After measuring PDH complex activity in an extracted sampled mitochondria were incubated (200mU-PDH complex/ml) with KCl medium/ 50μM-palmitoyl-carnitine/0.1%-fatty acid free BSA/0.5mM-malate (mitochondria from starved rats only) or KCl medium alone. Incubations were centrifuged (MSE18; 10 000g for 7-8min at 4°C), supernatants decanted and discarded. Pellets were resuspended and incubated with KCl medium/10μM-CCCP (200mU-PDH complex/ml) to reactivate PDH complex. Following this incubation mitochondria were aliquoted into cryotubes and centrifuged (eppendorf centrifuge; 13 000g for 30s at room temperature), supernatants aspirated (hypodermic needle and vacuum) and pellets frozen in liquid nitrogen. Pellets were thawed and resuspended with extraction buffer (50mM-KH₂PO₄/10mM-EGTA/2mM-DTT/1mM-MgCl₂/0.5mM-TLCK/1mM-benzamidine/10μM-leupeptin, pH 7.0 containing 50μg/ml oligomycin B) and then frozen and thawed x 2.

Rates of incorporation of ^{32}P from $[\gamma\text{-}^{32}\text{P}]\text{ATP}$ were measured in mitochondrial extracts by the paper squares method. Extracts were incubated with 0.5mM- $[\gamma\text{-}^{32}\text{P}]\text{ATP}$, samples were taken at 20, 40 and 60s (after the addition of ATP) and pipetted onto paper squares. Proteins adhering to the paper squares were precipitated by ice-cold 10%-TCA, paper squares were processed and the radioactivity counted. See text for details. Data represent means \pm SEM for 5 assays.

Incubation of heart mitochondria from 48h starved rats with palmitoyl carnitine induced a small increase in the rate of incorporation of ^{32}P from $[\gamma\text{-}^{32}\text{P}]$ into PDH complex (1.2-1.3 fold at each time point: $P < 0.05$). This increase was substantially less than the 2.45-fold increase in the rate of ATP-dependent inactivation induced by palmitoyl carnitine (Table 5.1; Fig 5.2).

For complete clarity specific details of experiments (data in Table 5.1) must be given. For each set of data where PDH kinase activities were measured by both the rate of inactivation (spectrophotometric method) of and the rate of incorporation of ^{32}P (paper squares method) into PDH complex, measurements were performed simultaneously and as follows. Each freshly prepared extract was divided into two equal portions. To one portion was added non-radioactive ATP solution and to the other $[\gamma\text{-}^{32}\text{P}]$ ATP solution simultaneously and samples taken at exactly the same time point, *i.e.* from one portion without radioactive ATP solution samples were added to cuvettes for spectrophotometric measurements, and at exactly the same time points samples of radioactive extracts were added to paper squares. Also, the concentration of ATP, added to each extract, in simultaneous inactivation and incorporation assays, was identical. 10mM- $[\gamma\text{-}^{32}\text{P}]$ ATP solutions were prepared using the non-radioactive 10mM-ATP solution used in inactivation assays and was prepared as follows. On the day of use, $[\gamma\text{-}^{32}\text{P}]$ ATP stock solution was dried down (see section 2 of this chapter) and the residue redissolved in the same non-radioactive ATP solution that was used in subsequent assays of rates of inactivation. Furthermore, in experiment 3 in Table 5.1 mitochondria from fed and 48h starved rats were prepared simultaneously.

Fig 5.3 shows the relationship between incorporation of ^{32}P from $[\gamma\text{-}^{32}\text{P}]$ ATP into PDH complex and the percent of PDH complex inactivated in extracts prepared from heart mitochondria of fed and 48h starved rats incubated \pm palmitoyl carnitine. The left hand panel shows the slopes of lines connecting the points in each of the four individual groups; the right hand panel shows lines of deduced fit connecting to zero incorporation and zero inactivation. The data show that in the absence of palmitoyl carnitine, the relationship between incorporation of ^{32}P from $[\gamma\text{-}^{32}\text{P}]$ ATP and inactivation of PDH complex is linear and the slope of this line is the same for mitochondrial extracts from both fed and 48h starved rats. As expected the rates of inactivation and incorporation are both greater in starved than in fed. The highest degree of

Figure 5.3 Relationship between rates of ATP dependent inactivation and of incorporation of ^{32}P from $[\gamma\text{-}^{32}\text{P}]\text{ATP}$ into PDH complex in extracts prepared from heart mitochondria, of fed and 48h starved rats incubated \pm palmitoyl carnitine (experiment 3 of Table 5.1)

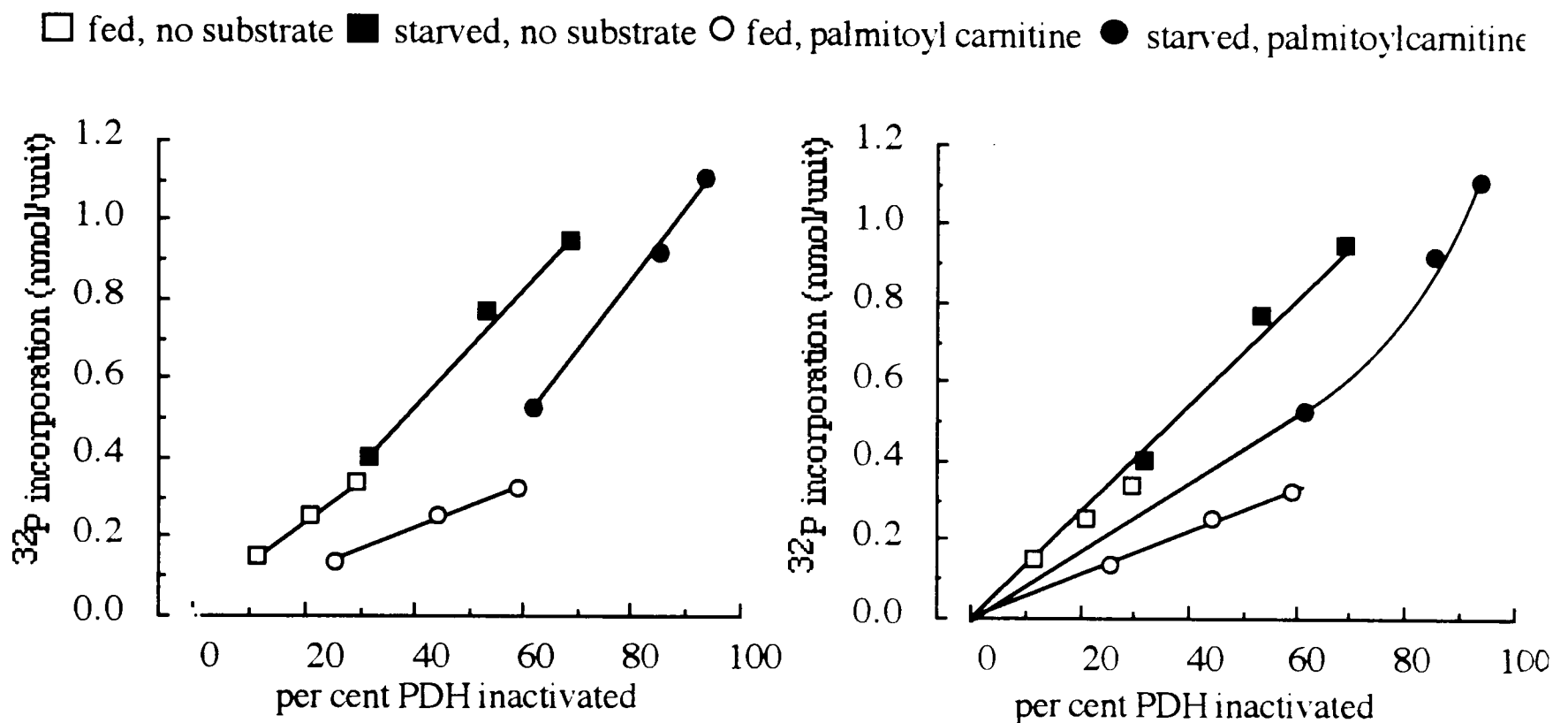

Heart mitochondria, from fed and 48h starved rats, were preincubated in KCl medium, 10min, 30°C to deplete endogenous substrates. After measuring PDH complex activity in an extract mitochondria were incubated (200mU-PDH complex/ml) with KCl medium containing 50 μM -palmitoyl-L-carnitine 0.1%-fatty acid free BSA/0.5mM-L-malate, or without substrate, for 15min at 30°C swirling gently every 5min. Incubations were centrifuged (MSE 18; 10 000g for 7-8min at 4°C. Pellets were resuspended and incubated in KCl medium/10 μM -CCCP (200mU-PDH complex/ml) for 30min at 30°C swirling gently every 5min to aerate the mitochondrial. Following this incubation mitochondria were aliquoted into cryotubes and centrifuged (eppendorf centrifuge; 13 000g for 30s at room temperature). Supernatants were aspirated (hypodermic needle and vacuum) and pellets frozen in liquid nitrogen. Pellets were thawed and resuspended in extraction buffer (50mM- KH_2PO_4 /10mM-EGTA/2mM-DTT/1mM- MgCl_2 /0.5mM-TLCK/1mM-benzamidine/10 μM -leupeptin, pH 7.0 containing 50 $\mu\text{g}/\text{ml}$ oligomycin B) and frozen and thawed x 2.

Extracts were used to measure rates of incorporation of ^{32}P from $[\gamma\text{-}^{32}\text{P}]\text{ATP}$ into PDH complex by the paper squares method and rates of ATP dependent inactivation. Rates of inactivation and rates of incorporation were measured using the same mitochondrial extracts divided into two and both types of assay were performed simultaneously: to one portion $[\gamma\text{-}^{32}\text{P}]\text{ATP}$ was added for incorporation assays and to the second portion non-radioactive ATP was added for inactivation assays. The 10mM- $[\gamma\text{-}^{32}\text{P}]\text{ATP}$ solution was prepared with the same non-radioactive 10mM-ATP solution added to inactivation assays. (See text for details). The amount of phosphorylated complex was determined from rate constants and incorporations of ^{32}P into PDH ^{32}P calculated from incorporation assays. Data represent means for at least 5 assays.

inactivation achieved was 63 per cent in starved after 1min and incorporation is therefore expected to be mainly in site 1 (Sale & Randle, 1980, 1982). With mitochondria from fed rats incubated with palmitoyl carnitine the linear relationship was maintained. As already described the rate of incorporation of ^{32}P from $[\gamma\text{-}^{32}\text{P}]\text{ATP}$ was unchanged whereas the rate of inactivation was enhanced resulting in a change of slope. With mitochondria from starved rats incubation with palmitoyl carnitine resulted in a curvilinear relationship; incorporation increased relatively more rapidly than inactivation. This could be attributed to accelerated phosphorylation of sites 2 and 3 in the PDH complex; in this group the percent of PDH complex inactivated was 60-94 per cent and accelerated phosphorylation of sites 2 and 3 is expected over this range (Sale & Randle, 1980, 1982)

Previous studies have shown that rates of incorporation of ^{32}P from $[\gamma\text{-}^{32}\text{P}]\text{ATP}$ into PDH complex are correlated with rates of inactivation of PDH complex in extracts of mitochondria from fed normal, 48h starved or alloxan-diabetic rats (Sale and Randle, 1980, 1982a). In the results shown here no such correlation was found between the increased rate of inactivation and rates of incorporation in respect of the palmitoyl carnitine effect in mitochondria from either fed or 48h starved rats. The mechanism of the palmitoyl carnitine effect to increase the rate of ATP dependent inactivation of PDH complex is therefore very different from that of starvation. Two possibilities have been considered. There is evidence both with purified ox and pig complexes that phosphorylation is half site, *i.e.* confined to one of the two alpha subunits in the E1 component of the complex (subunit composition: $\alpha_2\beta_2$) (Reed *et al.*, 1974; Sugden & Randle, 1978). Moreover phosphorylation stoichiometries per site in rat heart complex (approx. 0.8nmol P incorporated per unit of complex inactivated) are approximately twice those for pig heart complex. Therefore one possibility is that the palmitoyl carnitine effect in mitochondria is mediated by a switch from full site phosphorylation to half site phosphorylation (*i.e.* from formation of $\alpha_2\text{P}_2\beta_2$ to formation of $\alpha\text{P}\alpha\beta_2$). The other possibility that has been considered is that ATP dependent inactivation of PDH complex in extracts prepared from mitochondria incubated with palmitoyl carnitine might involve some mechanism other than phosphorylation.

The proportion of PDHP as a fraction of total PDH complex at complete conversion of PDH complex to PDHP is by definition equal to 100%. In the present study 48h starvation and incubation of mitochondria from these rats with palmitoyl carnitine shows that the proportion has reached 94% by 60s. Sale and Randle (1982b) showed that when complex is inactivated by greater than 99% incorporation, as in starvation, sites 2 and 3 contain the same amount of phosphate as site 1. It is likely therefore, with mitochondria from starved rats that at 94% inactivation incorporation into all sites would be nearly complete. The result here shows that near complete incorporation was 1.1nmol-phosphate/unit of complex-inactivated as compared with the usual value for rat heart PDH complex of 2.2nmol-phosphate/unit of complex-inactivated (Sale and Randle, 1980). The maximum incorporation of phosphate into PDH complex is unaltered by starvation or diabetes.

This is evidence therefore that palmitoyl carnitine incubation of rat heart mitochondria may change the maximum phosphorylation of PDH complex from a stoichiometry of 6 phosphates per 2 α -chains of the decarboxylase (full-site phosphorylation) to 3 phosphates per 2 α -chains (half-site phosphorylation). This is the first demonstration of such a change within species and *in vitro*. Species differences in phosphorylation stoichiometries have been reported, *e.g.* for pig heart complex complete phosphorylation is 1.25nmolP/unit of complex inactivated and is known to be half site (*i.e.* $\alpha_3\beta_2$); whereas for rat heart complex it is 2.2nmolP/unit of complex inactivated (*e.g.* Sale and Randle, 1980) and it has been assumed to be full-site (*i.e.* $\alpha_2\beta_2$). The difference *in vivo* may lie in the treatment of animals before slaughter. Pig hearts are obtained from abattoirs and the animals are subjected to the stress of mass slaughter, whilst rats are anaesthetised in comparatively tranquil surroundings. Because the shift in maximum phosphorylation can be effected *in vitro*, that found *in vivo* may not be due to species differences. To verify this deduced effect of palmitoyl carnitine on the stoichiometry of phosphorylation in mitochondria site occupancies and stoichiometries need to be measured more directly. Lack of laboratory equipment and time has precluded these investigations.

Similar measurements of rates of incorporation of phosphate into complex were made

using incubated extracts as in Chapter 4 and are presented in the next section.

16 Effect of incubation of rat heart mitochondrial extracts with palmitoyl-CoA (plus palmitoyl carnitine) on PDH kinase activities as measured by rates of ATP-dependent inactivation and incorporation of ^{32}P from $[\gamma\text{-}^{32}\text{P}]\text{ATP}$ into PDH complex.

Increased rates of ATP dependent inactivation of PDH complex have been demonstrated in extracts of mitochondria incubated with palmitoyl-CoA (+ palmitoyl carnitine) (see chapter 4). It was important to determine whether this was associated with altered rates of incorporation of ^{32}P from $[\gamma\text{-}^{32}\text{P}]\text{ATP}$ into PDH complex.

As shown in Table 5.2. and Fig 5.4 there were no obvious differences in rates of incorporation of ^{32}P from $[\gamma\text{-}^{32}\text{P}]\text{ATP}$ into PDH complex in mitochondrial extracts incubated for 0 or 10min \pm [palmitoyl-CoA + palmitoyl carnitine]. However, the rate of ATP dependent inactivation of PDH complex was increased approximately 2.4-fold by 10min of incubation with [palmitoyl-CoA + palmitoyl carnitine] (the effect of palmitoyl carnitine was not immediate but apparent after 10min incubation) (Table 5.2; Fig. 5.5). By contrast controls showed no change in the rate of inactivation over the 10min incubation period at 30°C.

(The amounts of phosphate incorporated in these experiments is rather greater than in experiments presented in Table 5.1. The reasons for this discrepancy are not known but may be the result of very high blanks or incorrect initial measurement of the specific activity of the radioactive ATP solution. The rate of ATP dependent inactivation is greater for fed (no substrate) in Table 5.3 than those in table 5.1 and the time points at which samples were taken for precipitation onto paper squares is 30, 60 and 90s in Table 5.3 compared with 20, 40, and 60s in Table 5.1 and from this it would be expected that the amount of phosphate incorporated would be greater. Despite these apparent differences the results in Table 5.3 clearly show that the rate of ATP-dependent inactivation is significantly increased (by 2.4 fold) by incubation of mitochondrial extracts for 10min at 30°C compared with that at 0min incubation or with no substrate incubated mitochondrial extracts either at 0 or 10min incubation at 30°C. No such increase was found with

Table 5.2 Rates of ^{32}P phosphorylation and ATP dependent inactivation of PDH complex in mitochondrial extracts incubated with or without palmitoyl-CoA plus palmitoyl carnitine

Incubation	min of incubation	Rate of ATP dependent inactivation (min^{-1})	^{32}P incorporation into PDH complex (nmol/U) at:-		
			20s	40s	60s
$50\mu\text{M-PCoA}/50\mu\text{M-PC}$	0	$0.45\pm 0.06(15)$	$0.38\pm 0.03(14)$	$0.55\pm 0.05(14)$	$0.76\pm 0.04(14)$
$50\mu\text{M-PCoA}/50\mu\text{M-PC}$	10	$1.10\pm 0.09(15)\text{\1	$0.45\pm 0.03(15)$	$0.70\pm 0.03(15)*_2$	$0.84\pm 0.04(15)$
no substrate	0	$0.43\pm 0.05(6)$	$0.51\pm 0.04(6)$	$0.86\pm 0.06(6)$	$0.93\pm 0.04(6)$
no substrate	10	$0.38\pm 0.04(6)\text{\dagger}^3$	$0.42\pm 0.03(6)$	$0.79\pm 0.05(6)$	$0.99\pm 0.06(6)$

P = palmitoyl; C = carnitine. Heart mitochondria were depleted of endogenous substrate by incubation with KCl medium for 10min at 30°C and swirled gently every 20s. A sample was taken from which mitochondria were extracted (see section 7) and PDH complex activity measured. Mitochondria were diluted to 200mU-PDH complex/ml with KCl medium, aliquoted into cryotubes, centrifuged, supernatant aspirated, and pellets frozen in liquid nitrogen. Pellets were thawed and resuspended in extraction buffer ($50\text{mM-KH}_2\text{PO}_4/10\text{mM-EGTA}/2\text{mM-DTT}/1\text{mM-MgCl}_2/0.5\text{mM-TLCK}/1\text{mM-benzamide}/10\mu\text{M-leupeptin}$, pH 7.0 containing $50\mu\text{g/ml}$ oligomycin B) and frozen and thawed x2.

Extracts were incubated with $50\mu\text{M-PCoA}$ and $50\mu\text{M-PC}$ or extraction buffer alone for 0 and 10min. Rates of incorporation of ^{32}P from $10\text{mM-}[\gamma\text{-}^{32}\text{P}]\text{ATP}$ (final concentration of 0.5mM) into PDHP complex was measured using the paper squares method (see section 10). Simultaneous measurement of rates of inactivation were measured in the same extracts using 10mM-ATP (final concentration 0.5mM) (see section 9). Rates of inactivation and rates of incorporation were measured using the same mitochondrial extracts divided into two and both types of assay were performed simultaneously: to one portion $[\gamma\text{-}^{32}\text{P}]\text{ATP}$ was added for incorporation assays and to the second portion non-radioactive ATP was added for inactivation assays. The $10\text{mM-}[\gamma\text{-}^{32}\text{P}]\text{ATP}$ solution was prepared with the same non-radioactive 10mM-ATP solution added to inactivation assays. (See text for details). Data represent means \pm SEMs of the number of assays given in parentheses. * $P < 0.05$, $\text{\dagger} P < 0.001$. The superscript denotes comparison: 1 PCoA at 0min versus that at 10min PCoA; 2 PCoA at 0min versus no substrate at 0min; 3 PCoA at 10min versus no substrate at 10min.

Figure 5.4 Incorporation of ^{32}P from $[\gamma\text{-}^{32}\text{P}]\text{ATP}$ into PDH complex in mitochondrial extracts incubated with or without [palmitoyl-CoA + palmitoyl carnitine]

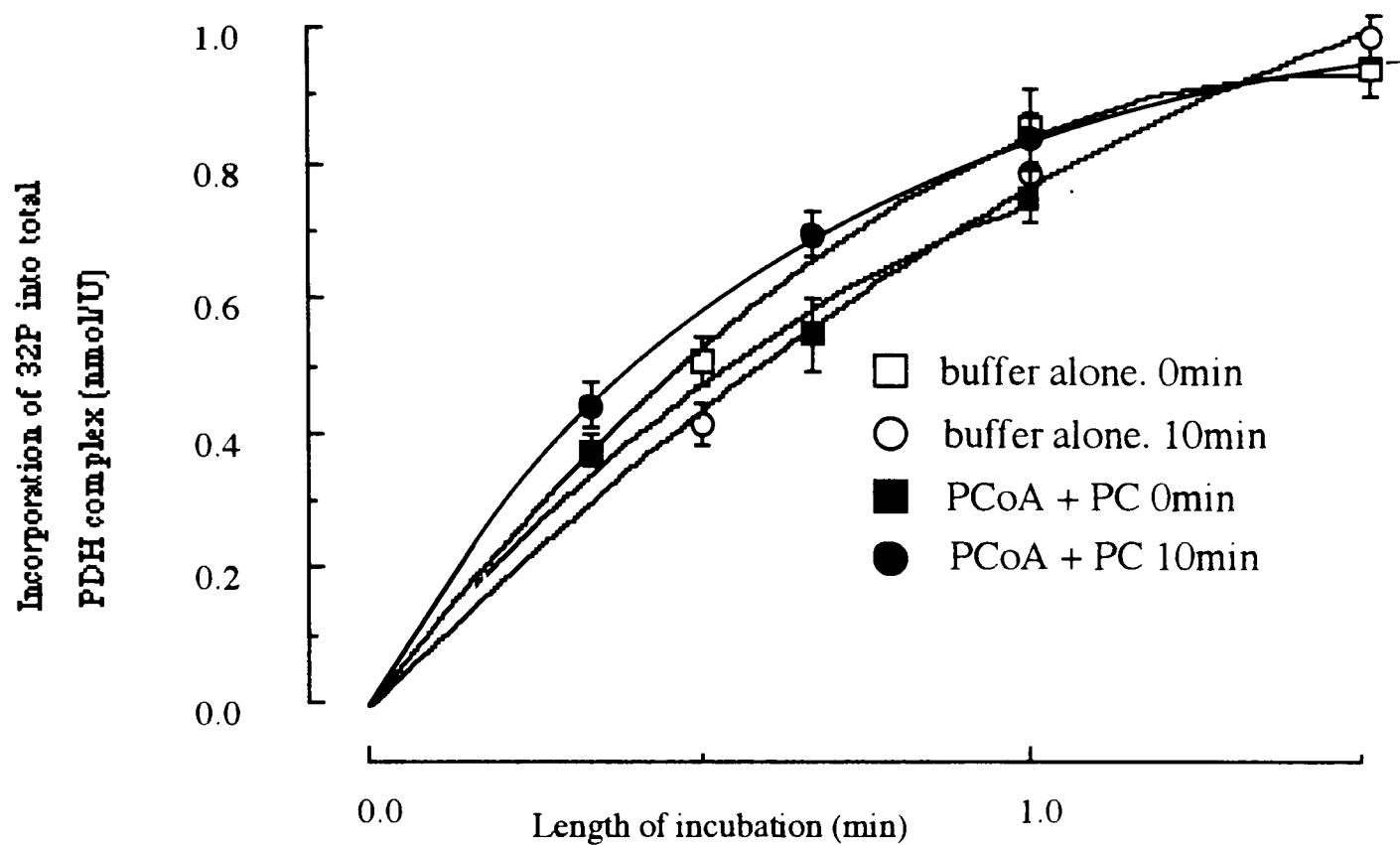

Mitochondria were depleted of endogenous substrate by incubation in KCl medium (120mM-KCl/20mM-Tris/5mM-EGTA/5mM-KH₂PO₄, pH 7.4) for 10min, at 30°C, and aerated every 20s. A sample was taken, mitochondria extracted and PDH complex activity measured. Mitochondria were diluted to 200mU-PDH complex/ml KCl medium, aliquoted into cryotubes and centrifuged (eppendorf centrifuge). Supernatants were aspirated (hypodermic needle and vacuum) and pellets frozen in liquid nitrogen. Pellets were thawed and resuspended with extraction buffer (50mM-KH₂PO₄/10mM-EGTA/2mM-DTT/1mM-MgCl₂/0.5mM-TLCK/1mM-benzamidine/10μM-leupeptin, pH 7.0 containing 50μg/ml oligomycin B) and frozen and thawed x 2.

Extracts were incubated in extraction buffer ± 50μM-palmitoyl-CoA (PCoA) + 50μM-palmitoyl-L-carnitine (PC) for 0 and 10min at 30°C. At 0 and 10min 10mM- $[\gamma\text{-}^{32}\text{P}]\text{ATP}$ was added to a final concentration of 0.5mM and incubated up to 1min. Rates of incorporation of ^{32}P from $[\gamma\text{-}^{32}\text{P}]\text{ATP}$ into PDH complex were measured using the paper squares method. At 20, 40 and 60s (for PCoA incubated extracts) or 30, 60 and 90s (for extracts incubated with extraction buffer alone) samples were pipetted onto paper squares. Proteins were precipitated onto the paper squares with 10% TCA. Paper squares were further processed and the radioactivity counted according to section 3. Data represent the means ± SEM for at least 6 assays

Figure 5.5 Rates of ATP-dependent inactivation of PDH complex with mitochondrial extracts incubated \pm palmitoyl-CoA and palmitoyl carnitine for 0 and 10min

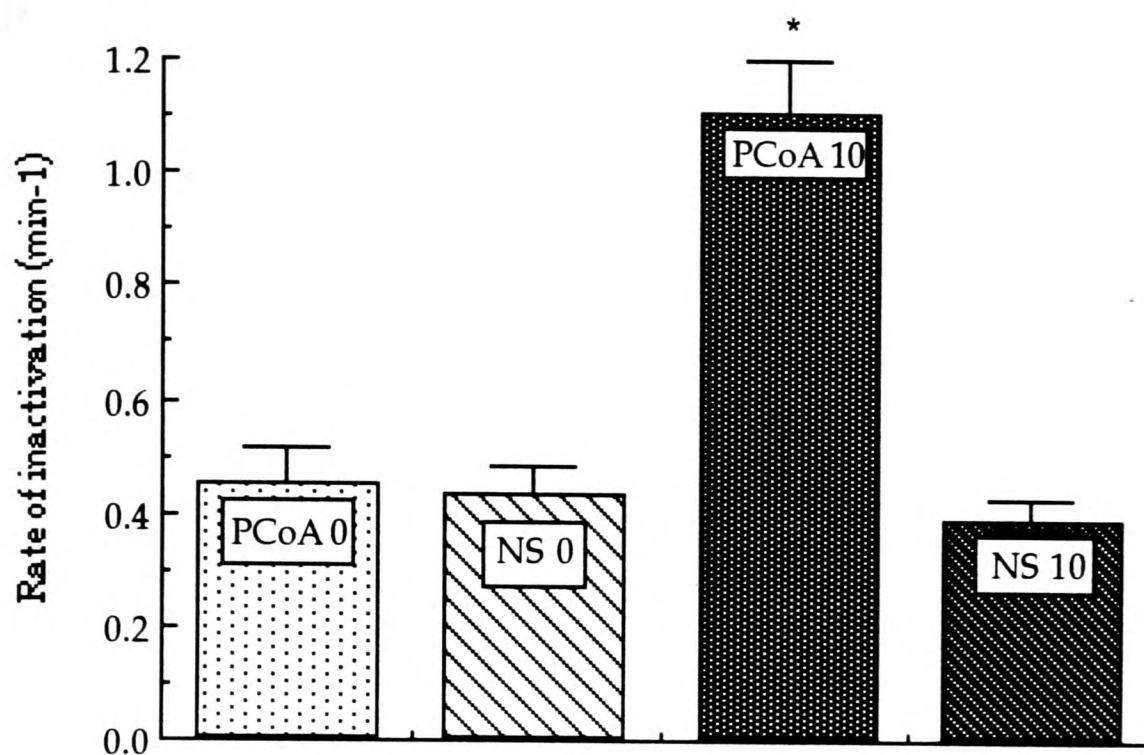

Mitochondria were depleted of endogenous substrate by incubating mitochondria with KCl medium (120mM-KCl/20mM-Tris/5mM-EGTA/5mM-KH₂PO₄, pH 7.4) without substrates for 10min, at 30°C, and gently swirled every 20s. A sample was taken, mitochondria extracted and PDH complex activity measured. Mitochondria were diluted to 200mU-PDH complex/ml KCl medium, aliquoted into cryotubes and centrifuged (ependorf centrifuge; 13 000g for 30s at room temperature). Supernatants were aspirated (hypodermic needle and vacuum) and pellets frozen in liquid nitrogen. Pellets were thawed and resuspended with extraction buffer (50mM-KH₂PO₄/10mM-EGTA/2mM-DTT/1mM-MgCl₂/0.5mM-TLCK/1mM-benzamidine/10 μ M-leupeptin, pH 7.0 containing 50 μ g/ml oligomycin B) and frozen and thawed x 2.

Extracts were incubated in extraction buffer containing 50 μ M-palmitoyl-CoA and 50 μ M-palmitoyl-carnitine or incubated in extraction buffer alone for 0 and 10min at 30°C. At 0 and 10min 10mM-ATP was added to a final concentration of 0.5mM and PDH kinase was measured as the rate of ATP dependent inactivation. 'NS 0' represents extracts incubated in extraction buffer alone for 0min, 'NS 10' the same as NS 0 but for 10min, 'CoA 0' extracts incubated with palmitoyl-CoA (PCoA) and palmitoyl carnitine (PC) for 0min, and 'PCoA 10' represents that incubated with palmitoyl-CoA and palmitoyl carnitine for 10min. Data represent means \pm SEM for at least 6 assays. * $P \leq 0.001$ for the effect of palmitoyl-CoA and palmitoyl carnitine at 10min compared with extracts incubated with palmitoyl-CoA and palmitoyl carnitine for 0min and that without for 0 and 10min.

rates of incorporation of ^{32}P from $[\gamma\text{-}^{32}\text{P}]\text{ATP}$ into PDH complex with these extract incubations.)

Figure 5.6 shows the relationship between incorporation of ^{32}P from $[\gamma\text{-}^{32}\text{P}]\text{ATP}$ into PDH complex and ATP dependent inactivation of PDH complex. These data were calculated from the incorporation of ^{32}P from $[\gamma\text{-}^{32}\text{P}]\text{ATP}$ into PDH complex given the corresponding rate constant from rates of ATP dependent inactivation of the complex (see table 5.2). The figure clearly shows that incubation of mitochondrial extracts with palmitoyl-CoA and palmitoyl carnitine for 10min approximately halves the amount of phosphate incorporation associated with inactivation of the complex.

This result shows that incubation of mitochondrial extracts with palmitoyl-CoA and palmitoyl carnitine may not increase the initial rate of incorporation of phosphate into PDH complex associated with enhanced rates of inactivation. The effect of palmitoyl-CoA in extracts of mitochondrial extracts appears to be comparable to that of palmitoyl carnitine incubation in whole mitochondria. There is an unexplained discrepancy between these findings and aspects of the effects of palmitoyl CoA in mitochondrial extracts on ATP dependent inactivation which requires further study.

The studies thus far have been based upon the proposition that the effects of palmitoyl carnitine in mitochondria and of palmitoyl-CoA in mitochondrial extracts to accelerate ATP dependent inactivation of PDH complex without effecting a corresponding increase in the rate of ^{32}P phosphorylation, is due to a change from full site to half site phosphorylation (*i.e.* from $\alpha_2\text{P}_2\beta_2$ to $\alpha\text{P}\alpha\beta_2$). It has seemed important to attempt to exclude the alternative possibility of a switch to inactivation by a non-phosphorylating mechanism.

17 Effect of non-phosphorylating analogue of ATP on the rate of inactivation of PDH complex with extracts of mitochondria previously incubated with palmitoyl carnitine.

A possible alternative mechanism whereby palmitoyl carnitine alters the conformation of complex or kinase allowing allosteric binding of ATP would cause inactivation of the complex, without altering incorporation of phosphate into the complex. 5'-adenylylimidodiphosphate

Figure 5.6 Incorporation of ^{32}P from $[\gamma\text{-}^{32}\text{P}]\text{ATP}$ incorporated into inactivated PDH complex with mitochondria extracts incubated in the presence or absence of palmitoyl-CoA for 0 and 10min

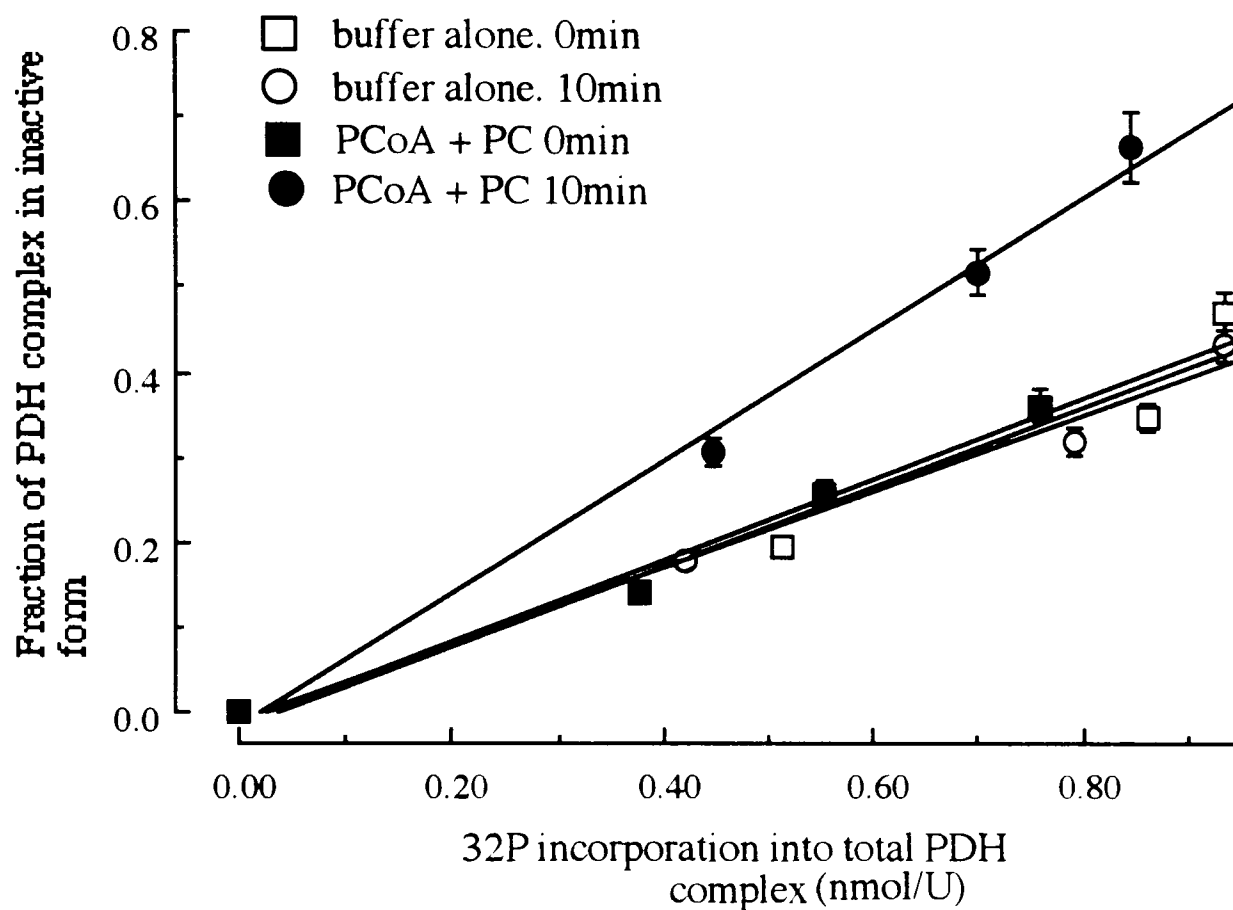

Mitochondria were depleted of endogenous substrate by incubation in KCl medium (120mM-KCl/20mM-Tris/5mM-EGTA/5mM-KH₂PO₄, pH 7.4) for 10min, at 30°C, and aerated every 20s. A sample was taken, mitochondria extracted and PDH complex activity measured. Mitochondria were diluted to 200mU-PDH complex/ml KCl medium, aliquoted into cryotubes and centrifuged (Eppendorf centrifuge). Supernatants were aspirated and pellets frozen in liquid nitrogen. Pellets were thawed and resuspended with extraction buffer (EB) (50mM-KH₂PO₄/10mM-EGTA/2mM-DTT/1mM-MgCl₂/0.5mM-TLCK/1mM-benzamidine/10μM-leupeptin, pH 7.0 containing 50μg/ml oligomycin B) and frozen and thawed x 2.

Extracts were incubated in extraction buffer ± 50μM-palmitoyl-CoA (PCoA) and 50μM-palmitoyl carnitine (PC) for 0 and 10min at 30°C. At the end of incubation 10mM- $[\gamma\text{-}^{32}\text{P}]\text{ATP}$ was added to a final concentration of 0.5mM. Rates of incorporation of ^{32}P from $[\gamma\text{-}^{32}\text{P}]\text{ATP}$ into PDH complex were measured by the paper squares method at 20, 40 and 60s (PCoA incubations) or 30, 60 and 90s (buffer alone). PDH kinase activity was measured by ATP dependent inactivation of PDH complex in the same extracts at 0 and 10min. The amount of phosphorylated complex was determined from rate constants and incorporations of ^{32}P into PDH ^{32}P calculated from incorporation assays. Data represent the means ± SEM for at least 15 assays.

(AMP-PNP) is a non-phosphorylating analogue of ATP. It contains adenosine and three phosphate groups with the terminal phosphate linked through an -NH group instead of an oxygen. From competition studies (Cooper *et al.*, 1974) AMP-PNP binds to the active site of PDH kinase but is unable to phosphorylate PDH complex. Inactivation of PDH complex by allosteric binding of AMP-PNP (and the absence of ATP) would indicate an allosteric function of ATP which is not associated with phosphorylation by PDH kinase. Standardised stock solution of AMP-PNP (see section 4) was added to mitochondrial extracts in exactly the same way as ATP was used in inactivation assays, to a final concentration of 0.5mM. Extracts used were of mitochondria that had been incubated with or without palmitoyl carnitine. The results in Figure 5.7 show that in inactivation assays where AMP-PNP was substituted for ATP there was no inactivation of PDH complex activity, either in palmitoyl carnitine incubated mitochondria nor in controls. In inactivation assays where H₂O was substituted for ATP no inactivation was detected in any extract. This supports the conclusion that the effect of palmitoyl carnitine to accelerate ATP dependent inactivation involves phosphorylation of PDH complex.

18 Effects of known PDH kinase inhibitors on the rate of ATP-dependent inactivation of PDH complex in extracts of mitochondria previously incubated with palmitoyl carnitine.

Hutson and Randle (1978) found in extracts of mitochondria prepared from fed, 48h starved and alloxan-diabetic rats, that incubation with pyruvate (a known inhibitor of PDH kinase) inhibited PDH kinase activities as measured by rates of incorporation and inactivation. The starved-fed and diabetic-fed differences in kinase activities were nevertheless maintained even in the presence of pyruvate. This showed that some stable factor was stimulated by starvation and diabetes that specifically increases PDH kinase activity. The experiments presented here were designed to see if the activation of PDH kinase by palmitoyl carnitine is retained in the presence of known inhibitors of PDH kinase. The inhibitors chosen were ADP (competitive with ATP, and TPP and pyruvate which are uncompetitive inhibitors (Linn *et al.*, 1969; Cooper *et al.*, 1974)). Known inhibitor constants (K_i) are 28.4 μ M-ADP (pig heart

Figure 5.7 Effects of ATP and of AMP-PNP (adenylyl imidodiphosphate) on activity of PDH complex in extracts of mitochondria previously incubated \pm palmitoyl carnitine

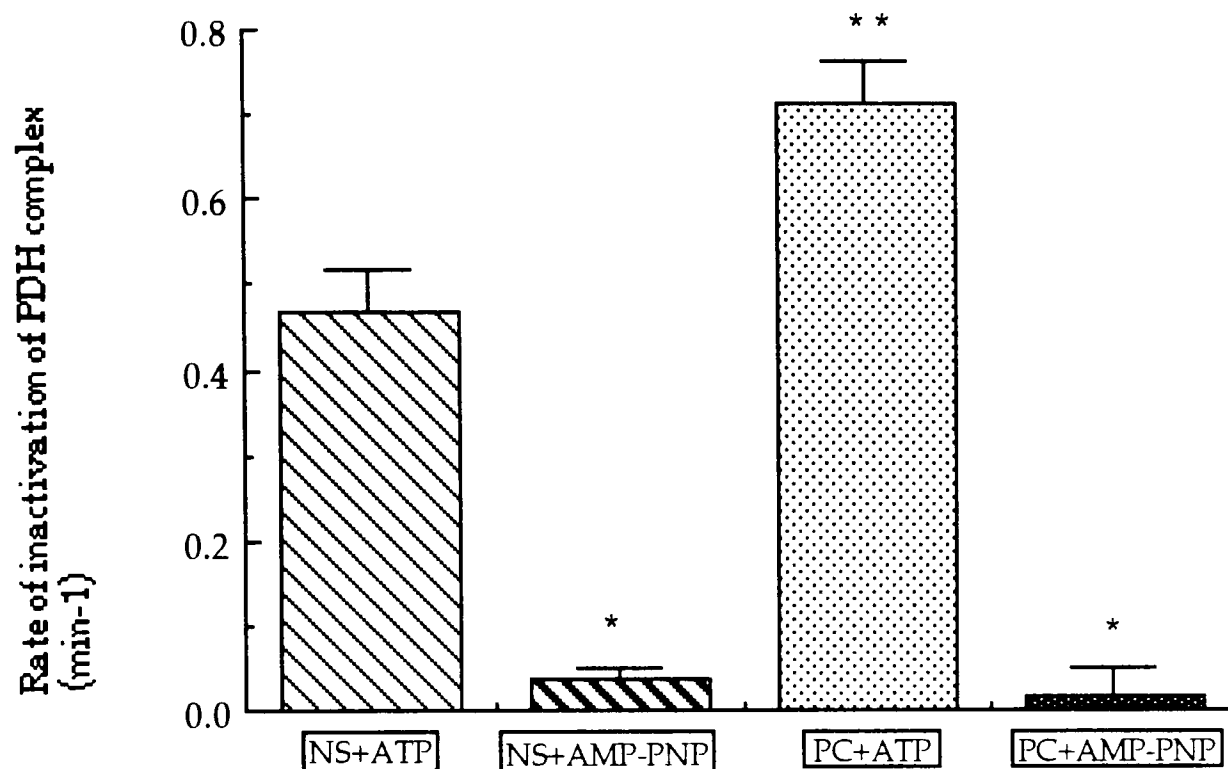

Following preincubation to deplete mitochondria of endogenous substrate, heart mitochondria were incubated (200mU-PDH complex/ml) in KCl medium \pm 50 μ M-palmitoyl-L-carnitine, 0.1%-fatty acid free BSA, 0.5mM-L-malate, for 15min at 30°C aerating every 5min. Incubations were centrifuged (MSE 18; 10 000g for 7-8min at 4°C). Supernatants were decanted and discarded and pellets resuspended and incubated in KCl medium/10 μ M-CCCP (200mU-PDH complex/ml) for 30min at 30°C, aerating every 5min. Following this incubation mitochondria were aliquoted into cryotubes and centrifuged (ependorf centrifuge,) supernatants aspirated and pellets frozen in liquid nitrogen. Pellets were thawed and resuspended in extraction buffer (50mM-KH₂PO₄/10mM-EGTA/2mM-DTT/1mM-MgCl₂/1mM-benzamidine/0.5mM-TLCK/10 μ M-leupeptin. pH7.0 containing 50 μ g-oligomycin B/ml) and frozen and thawed x 2.

Rates of inactivation were measured in these extracts using stock ATP or AMP-PNP solutions (final concentrations in assays of 0.5mM each). 'PC+ATP' = extracts of mitochondria previously incubated with palmitoyl-carnitine in assays containing 0.5mM ATP; 'PC+AMP-PNP' = the same extracts used in assays with 0.5mM-AMP-PNP; 'NS+ATP' = extracts of mitochondria incubated without substrate used in assays with 0.5mM-ATP; 'NS+AMP-PNP' = extracts of mitochondria incubated without substrate and inactivation assays measured with 0.5mM-AMP-PNP. Data are means \pm SEM for 3 assays. * denotes $P < 0.001$ for the effect of ATP versus AMP-PNP for palmitoyl-carnitine incubated and extracted mitochondria (no substrate) and ** denotes $P < 0.01$ for the effect of PC incubation of mitochondria versus no substrate incubated and extracted mitochondria (both +ATP).

complex), 20 μ M-TPP (pig heart complex) and 0.95mM-pyruvate (rat heart complex) (Cooper *et al.*, 1974). The K_m for ATP was assumed to be 10 μ M. The concentrations of inhibitors used were calculated to approximately halve the velocity of the kinase reaction.

Figure 5.8 shows initial PDH complex activities at 60s following addition of 10mM-ATP as a percentage of PDH complex at zero/time. Pyruvate and the pyruvate plus ADP mixture gave essentially complete inhibition of ATP dependent inactivation ($P < 0.001$); TPP inhibited kinase activity approximately 25 per cent ($P < 0.01$); and ADP had no detectable inhibitory effect. One possible explanation for the lack of an ADP effect is that contaminating myokinase in extracts might convert ADP to ATP and AMP thus nullifying the ADP effect..

Figure 5.9 shows the results of further experiments in which the effects of PDH kinase inhibitors with measured with extracts of mitochondria from fed rats incubated with palmitoyl carnitine and of mitochondria from 48h starved rats incubated with or without palmitoyl carnitine. Results are expressed as rate constants for ATP dependent inactivation. From this figure, ADP-pyruvate mix had the greatest inhibitory effect on kinase activity in all extracts and inhibition was almost complete ($P < 0.001$). Pyruvate was almost as effective as ADP-pyruvate mix ($P < 0.001$). TPP had a detectable effect to inhibit kinase activity ($P < 0.05$) for all extracts compared with control kinase activities in the same extracts. ADP alone had a perceptibly small but insignificant inhibitory effect. The effect of the ADP-pyruvate mix was marginally greater than that of pyruvate alone.

The PDH kinase inhibitors, both competitive and uncompetitive, investigated above were effective at inhibiting kinase activity of extracts of mitochondria previously incubated in medium containing palmitoyl carnitine. Although kinase activities were inhibited, the fed-starved difference remained. Similar results were found by Hutson and Randle (1978). The more important result for the purposes of the present study is that the enhanced kinase activities of extracts of mitochondria were sensitive to known kinase inhibitors. In particular the ADP pyruvate mix gave virtually complete inhibition of ATP dependent inactivation of PDH complex in all three groups *viz* fed with palmitoyl carnitine and starved with or without palmitoyl carnitine.

Figure 5.8 Percentage PDH complex activity at 60s/initial activity after the addition of ATP in extracts of mitochondria from fed rats incubated without substrate

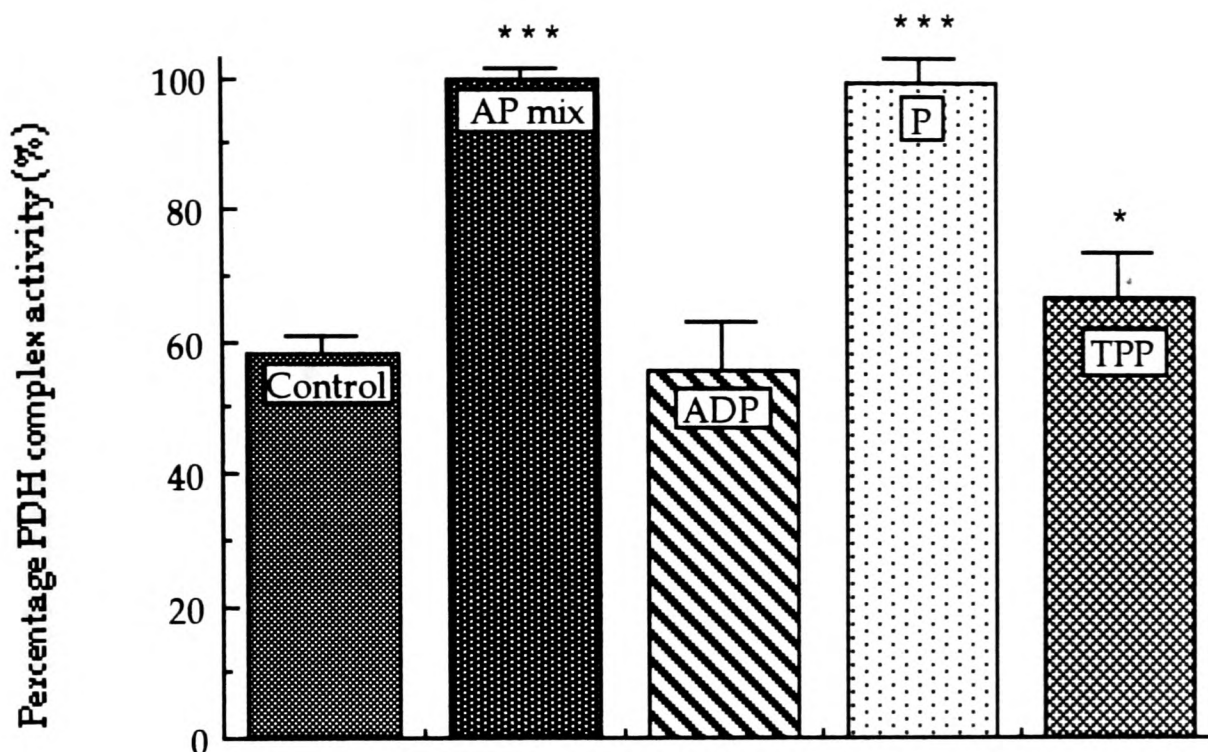

Mitochondria were incubated in KCl medium (120mM-KCl/20mM-Tris/5mM-EGTA/5mM-KH₂PO₄, pH 7.4) for 10min at 30°C swirling every 20s. A sample of mitochondria was taken, extracted and the PDH complex activity measured. Mitochondria were diluted to 200mU-PDH complex/ml with KCl medium, aliquoted into cryotubes and centrifuged (Eppendorf centrifuge). Supernatants were aspirated (hypodermic needle and vacuum) and pellets frozen in liquid nitrogen. Pellets were thawed and resuspended in extraction buffer (50mM-KH₂PO₄/10mM-EGTA/2mM-DTT/1mM-MgCl₂/0.5mM-TLCK/1mM-benzamidine/10μM-leupeptin, pH 7.0 containing 50μg/ml oligomycin B).

The PDH complex activity was measured in extracts in the presence of PDH kinase inhibitors, before and after the addition of 10mM-ATP to 0.5mM and expressed as percentage PDH complex activity at 60s/initial activity. The inhibitors were:- 'AP mix' = 1.42mM-ADP+ 0.95mM-pyruvate; 'ADP' = 1.42mM-ADP; 'P' = 0.95mM-pyruvate; 'TPP' = 20μM-TPP; 'Control' = extraction buffer alone. Data represent means ± SEM for 4 to 16 assays. *** represents P<0.001 and * P<0.05 for the effect of inhibitor compared with control.

Figure 5.9 Effect of PDH kinase inhibitors on rates of ATP dependent inactivation of PDH complex in extracts prepared from heart mitochondria, of fed and 48h starved rats, incubated \pm palmitoyl carnitine

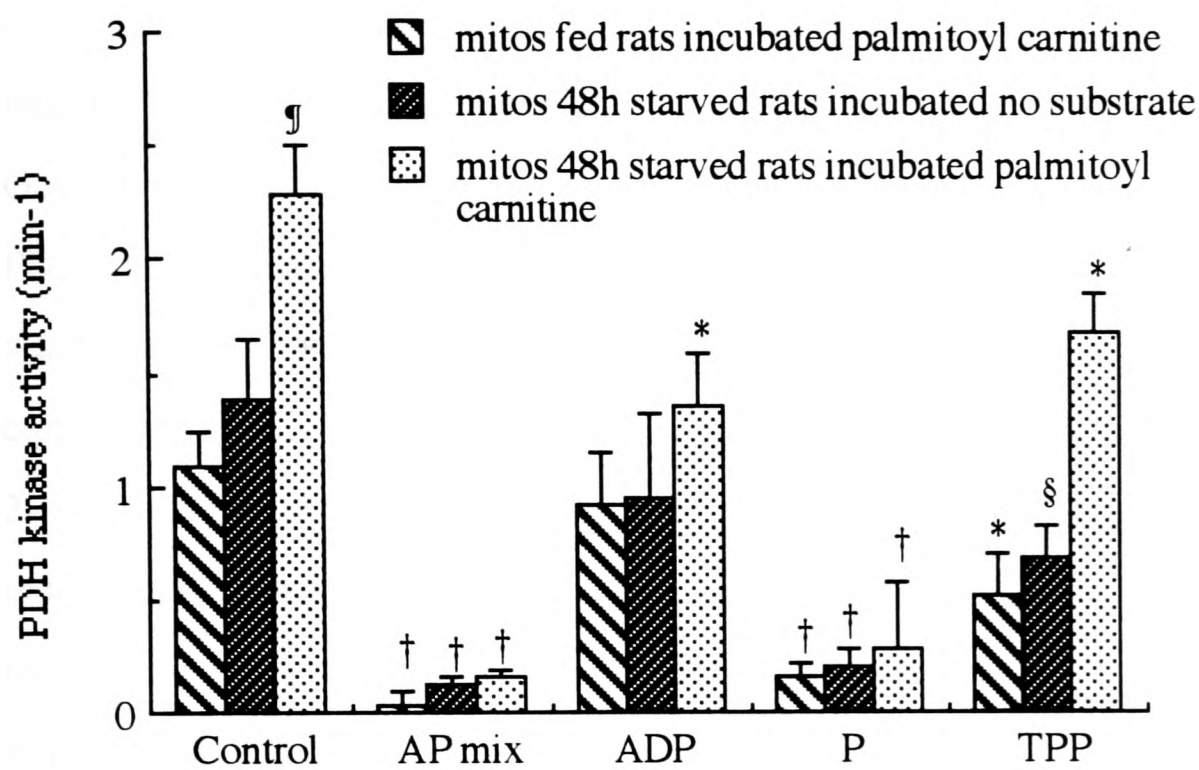

Heart mitochondria from fed and 48h starved rats were incubated for 10min at 30°C and gently swirled every 20s to deplete mitochondria of substrate. A sample of mitochondria was taken, extracted and the PDH complex activity was measured. Mitochondria were diluted to a concentration of 200mU-PDH complex/ml and incubated with KCl medium (120mM-KCl/20mM-Tris/5mM-EGTA/5mM-KH₂PO₄, pH 7.4) with or without 50 μ M-palmitoyl-carnitine, 0.1%-fatty acid free BSA, 0.5mM-malate for 15min at 30°C, swirling every 5min. Incubates were centrifuged (MSE18; 10 000g for 7-8min at 4°C). Supernatants were decanted and discarded and pellets were resuspended and PDH complex activated by incubating mitochondria in KCl medium/10 μ M-CCCP for 30min at 30°C swirling every 5min. Incubates were aliquoted into cryotubes and centrifuged (eppendorf centrifuge; 30s at 13 000g at room temperature). Supernatants were aspirated (hypodermic needle and vacuum) and pellets frozen in liquid nitrogen. Pellets were thawed and resuspended in extraction buffer (50mM-KH₂PO₄/10mM-EGTA/2mM-DTT/1mM-MgCl₂/0.5mM-TLCK/1mM-benzamidine/10 μ M-leupeptin, pH 7.0 containing 50 μ g/ml oligomycin B) and frozen and thawed x 2.

PDH kinase activity measured by rates of ATP dependent inactivation in the presence (or absence) of kinase inhibitors. These inhibitors and final concentrations in assays were AP mix = 1.42mM-ADP and 0.95mM-pyruvate, ADP = 1.42mM-ADP, pyruvate = 0.95mM-pyruvate, TPP = 20 μ M-TPP or Control = extraction buffer. Full details of experiments are given in the text. Data are means \pm SEM for between at least 5 assays. † represents P<0.001, § P<0.01 * P<0.05 for the effect of inhibitor compared with its control; ¶ P=0.001 for the palmitoyl carnitine effect on PDH kinase from mitochondria from 48h starved rats, incubated with palmitoyl-carnitine versus that incubated without palmitoyl-carnitine, or that from palmitoyl carnitine incubated fed mitochondria.

19 Effect of incubation of heart mitochondria, prepared from fed and 48h starved rats, in the presence of palmitoyl carnitine on rates of reactivation and of release of $^{32}\text{P}_i$ from [^{32}P]-phosphorylated PDH complex.

PDH phosphatase catalyses the dephosphorylation of phosphorylated PDH complex. It requires Mg^{2+} ; in the presence of Mg^{2+} it is activated by Ca^{2+} ; and it is inhibited by F^- (see General Introduction for further details.) Sugden *et al.* (1978) found using purified pig heart PDH complex that rates of reactivation of fully phosphorylated complex by PDH phosphatase were less than with complex phosphorylated predominantly in site 1. Reactivation was linearly correlated with dephosphorylation of site 1 and relative rates of dephosphorylation of sites are $2 > 1 = 3$ (rat heart mitochondria Sale and Randle, 1980, 1982). There is a substantial literature indicating that phosphorylation of sites 2 and 3 may retard dephosphorylation of site 1 and reactivation of the complex (see also Kerbey and Randle, 1979; Sugden and Simister, 1980; Kerbey *et al.*, 1981). The object of the experiments in this section was to provide evidence that PDH phosphatase reactivates PDH complex following ATP dependent inactivation of extracts prepared from mitochondria incubated \pm palmitoyl carnitine. It was therefore necessary to attempt to achieve comparable site occupancies in PDH complexes in extracts of mitochondria incubated \pm palmitoyl carnitine. It was not possible to measure site occupancies but in carrying out ATP dependent inactivation incubation times were adjusted to give approximately 90 per cent inactivation (three half lives).

The results from the section above (kinase inhibitors) provided useful information that allowed rates of reactivation to be measured using endogenous PDH phosphatase in extracts of mitochondria previously incubated with palmitoyl carnitine. Rates of reactivation of phosphorylated PDH complex were measured in extracts of mitochondria prepared from fed and 48h starved rat hearts and previously incubated \pm palmitoyl carnitine. Following inactivation of PDH complex by incubation with 10mM-ATP (final concentration 0.5mM in the assay), kinase activity was inhibited with 1.42mM-ADP plus 0.95mM-pyruvate (see section 11) and phosphatase activated by addition of Mg^{2+} and Ca^{2+} . Pyruvate + ADP inhibit PDH kinase activity but have no effect on phosphatase activity (Linn *et al.*, 1969a,b; Cooper *et al.*, 1974);

Ca^{2+} also inhibits PDH kinase activity (Cooper *et al.*, 1974). The results are listed in table 5.3 and plotted in Figure 5.10.

Figure 5.10 shows that the rate of reactivation of PDH complex inactivated by incubation with ATP activity was not altered by incubation of mitochondria, from fed rats with palmitoyl carnitine. Rates of reactivation were lower in extracts of mitochondria from 48h starved rats in comparison with fed (by 1.8 to 3 fold, $P < 0.001$ for all time points). The reason for this difference is not known. Palmitoyl carnitine may have had some effect to increase rates of reactivation in 48h starved mitochondria ($P < 0.05$ at 15 min and $P < 0.001$ at 60 min but no significant differences were found at other time points).

Rates of decrease of [^{32}P]phosphorylated PDH complex (measured as TCA insoluble ^{32}P) were measured with extracts of mitochondria from fed rats that had been incubated \pm palmitoyl carnitine (see section 12) and the results are given in Table 5.4 and Figure 5.11. The data show that the rate of release of ^{32}P from phosphorylated complex is unaltered by incubation of mitochondria with palmitoyl carnitine. The results are expressed as a percentage of values at zero time for each run and then the percentages were combined for the overall mean \pm SEM. This method of calculation was chosen because the blanks were very large.

(The results of these experiments indicates that 50% of radioactive accounts were present at 60min compared with nearly 100% reactivation under the same conditions and at the same time point (60min). Reasons for this difference may included non specific binding of radioactive ATP to the paper squares, non specific binding of radioactive ATP to non PDH complex proteins that precipitated onto paper squares, although these should have been small, blanks were large and the reasons for this are unknown. Some radioactivity may also have been present in sites 2 and 3 of the complex as incubations under phosphorylating conditions were expected to incorporate phosphate by up to 90%. Whilst site 2 is inactivating site 3 is not and even though site 3 is dephosphorylated at an equal rate with site 1, phosphate may still be present at this site. The reasons for incomplete release of radioactive phosphate compared with near complete reactivation under similar conditions may not be explained by simply one of the above reasons but more likely a combination. However, the important result shown by these data is that palmitoyl

Table 5.3 Effect of incubation of mitochondria, from fed and 48h starved rats, with palmitoyl-carnitine on the rates of reactivation of phosphorylated PDH complex by endogenous PDH phosphatase in mitochondrial extracts

Mitochondria and incubation	Percentage of total PDH complex activity at					60 (min)
	0	5	15	30	45	
fed						
50 μ M-PC/0.5mM-malate	12.5 \pm 1.80(14)	22.9 \pm 3.78(4)	49.0 \pm 4.09(8)	71.8 \pm 3.84(8)	89.6 \pm 3.72(4)	98.9 \pm 1.89(4)
no substrate	10.5 \pm 0.93(19)	23.5 \pm 3.38(10)	51.9 \pm 2.30(6)	67.1 \pm 4.26(6)	82.3 \pm 2.36(6)	99.4 \pm 1.75(6)
48h starved						
50 μ M-PC/0.5mM-malate	3.72 \pm 0.76(6) ^{†2}		27.4 \pm 3.65(6) ^{*1†2}	43.8 \pm 4.69(6) ^{†1§2}	56.0 \pm 3.19(6) ^{§2}	68.3 \pm 3.36(4) ^{§1,2}
no substrate	3.90 \pm 1.04(6) ^{§3}		16.7 \pm 1.63(6) ^{§3}	33.6 \pm 1.54(6) ^{§3}	43.6 \pm 5.94(6) ^{§3}	54.5 \pm 0.87(4) ^{§3}

PC, palmitoyl carnitine. *P<0.05, †P<0.01, §P<0.001. The superscript number denotes the comparisons: ¹ 48h starved no substrate versus 48h starved PC; ² fed PC versus 48h starved PC; ³ fed no substrate versus 48h starved no substrate. Heart mitochondria from fed and 48h starved rats, were preincubated in KCl medium for 10min at 30°C to remove endogenous substrates (see section 6) and then incubated in KCl medium \pm 50 μ M-PC/ 0.1%-fatty acid free BSA/ 0.5mM-malate for 15min at 30°C and aerated every 5min, centrifuged (MSE 18; 10 000g, 7-8min, 4°C), pellets resuspended and incubated in KCl medium/10 μ M-CCCP for 30min at 30°C to reactivate PDH complex. Mitochondria were aliquoted into cryotubes, centrifuged (ependorf centrifuge) and pellets frozen in liquid nitrogen. Pellets were extracted with 50mM-KH₂PO₄/10mM-EGTA/2mM-DTT/1mM-MgSO₄/0.5mM-TLCK/1mM-benzamidine/10 μ M-leupeptin, pH 7.0 containing 50 μ g-oligomycin B/ml and frozen and thawed x2.

Rates of ATP dependent inactivation were measured and the length of time needed to effect 90% inactivation by phosphorylation of PDH complex by calculated (see section 9) with samples diluted to 2U-initial PDH complex/ml with extraction buffer and ATP (10mM). Samples were then divided and incubated \pm ATP for the requisite time. PDH phosphatase assay buffer (0.1m-Tris-HCl/2.5mM-CaCl₂/125mM-MgCl₂/5mM-EDTA, pH 8.4) containing PDH kinase inhibitors added to yield final concentrations of 1.42mM-ADP and 0.95mM-pyruvate). Extracts were incubated at 30°C for up to 65min and samples taken for assay of PDH complex activity at suitable intervals (see section 11). Results are expressed as percentages of initial PDH complex activity (*i.e.* prior to addition of ATP).

Figure 5.10 Effect of incubation of mitochondria \pm palmitoyl carnitine on the rate of reactivation of phosphorylated PDH complex in extracts of mitochondria from fed and 48h starved rats.

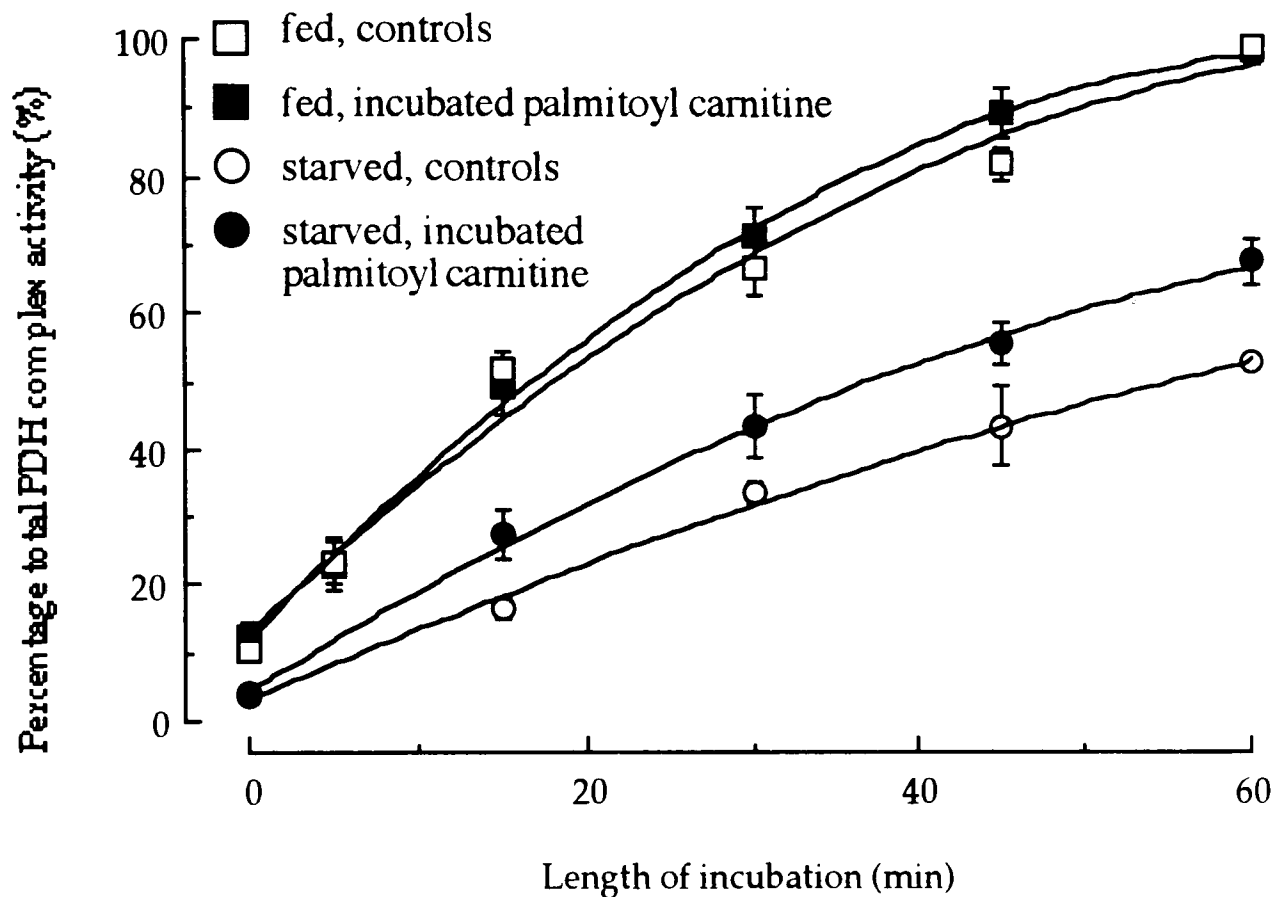

Heart mitochondria, from fed and 48h starved rats, were preincubated in KCl medium for 10min at 30°C to remove endogenous substrates and incubated (200mU-PDH/ml) with KCl medium \pm 50 μ M-palmitoyl-carnitine/0.1%-fatty acid free BSA /0.5mM-malate for 15min at 30°C and aerated every 5min. Mitochondrial pellets (MSE 18; 10 000g, 7-8min, 4°C), were resuspended and incubated in KCl medium/10 μ M-CCCP for 30min at 30°C and aerated every 5min to reactivate PDH complex, aliquoted into cryotubes and centrifuged (eppendorf centrifuge) and pellets frozen in liquid nitrogen. Pellets were extracted with 50mM-KH₂PO₄/10mM-EGTA/2mM-DTT/1mM-MgCl₂/0.5mM-TLCK/1mM-benzamidine/10 μ M-leupeptin, pH 7.0 containing 50 μ g-oligomycin B/ml and frozen and thawed x 2. Extracts were used to measure PDH phosphatase.

The length of time to effect 90% inactivation by phosphorylation of PDH complex was determined. Samples were diluted to 2U-initial PDH complex/ml with extraction buffer and divided into two equal portions. To one was added 0.1 volume of 10mM-ATP and an equal volume of H₂O to the other. Following incubation at 30°C for the calculated length of time to phosphorylate complex PDH phosphatase assay buffer (0.1mM-Tris-HCl/2.5mM-CaCl₂/125mM-MgCl₂/5mM-EDTA, pH 8.4) and ADP-pyruvate mix were added. (Final concentrations of kinase inhibitors were 1.42mM-ADP and 0.95mM-pyruvate.) Extracts were incubated at 30°C for up to 65min during which samples were taken periodically and assayed for PDH complex activity. The results are expressed as the percentage PDH complex activity at time *t* of initial PDH complex activity (*i.e.* before adding ATP). Data represent means \pm SEMs from three experiments with fed rats and two with 48h starved rats. $P < 0.01$ for differences between fed and starved

Table 5.4 Effect of incubation of rat heart mitochondria with palmitoyl-carnitine on the rate of release of ^{32}P from mitochondrial PDH complex phosphorylated with $[\gamma\text{-}^{32}\text{P}]\text{ATP}$

mitochondrial incubation	Loss of ^{32}P from PDH ^{32}P (percentage of initial radioactivity at:-				
	0	15	30	45	60 (min)
$50\mu\text{M-PC}/0.5\text{mM-malate}$	100±2.88(8)	85.7±4.03(6)	69.4±0.82(6)	54.6±0.65(6)	49.6±1.08(6)
no substrate	100±6.35(8)	90.6±5.08(6)	73.2±6.21(6)	65.1±4.48(6)	49.0±2.08(6)

PC = palmitoyl carnitine.

Heart mitochondria, from fed rats, were preincubated in KCl medium for 10min at 30°C to deplete endogenous substrates (see section 6) and after assay of PDH complex on an extracted sample, were incubated (200mU-PDH/ml) in KCl medium $\pm 50\mu\text{M-PC}/0.1\%$ -fatty acid free BSA/ 0.5mM-L-malate for 15min at 30°C and aerated every 5min. After centrifugation (MSE 18; 10 000g for 7-8min at 4°C), pellets were resuspended and incubated with KCl medium/ $10\mu\text{M-CCCP}$ for 30min at 30°C and aerated every 5min to reactivate PDH complex. Mitochondria were aliquoted into cryotubes, centrifuged (eppendorf centrifuge) and pellets frozen in liquid nitrogen. Pellets were thawed and resuspended with extraction buffer (50mM-KH₂PO₄/10mM-EGTA/2mM-DTT/1mM-MgCl₂/0.5mM-TLCK/1mM-benzamide/10 $\mu\text{M-leupeptin}$, pH 7.0 containing 50 $\mu\text{g-oligomycin B/ml}$) and frozen and thawed x2.

Extracts were used to measure PDH phosphatase by the rates of release of ^{32}P from ^{32}P phosphorylated PDH complex. Rates of ATP dependent inactivation were measured to calculate the length of time needed to effect 90% inactivation and phosphorylation of PDH complex by incubating extracts with ATP (see section 9). Samples were diluted to 2U-initial PDH complex/ml with extraction buffer and divided into two equal portions. To one was 0.11 vol of 10mM- $[\gamma\text{-}^{32}\text{P}]\text{ATP}$ and the equivalent vol. of H₂O to the other. Following incubation at 30°C for the calculated length of time PDH phosphatase assay buffer (0.1m-Tris-HCl/2.5mM-CaCl₂/125mM-MgCl₂/5mM-EDTA, pH 8.4) and PDH kinase inhibitor mix (final concentrations 1.42mM-ADP and 0.95mM-pyruvate). Extracts were incubated at 30°C for up to 60min during which samples were taken periodically onto paper squares (see section 12). Paper squares were processed and the radioactivity counted (see section 3). Results are expressed as percentage protein bound radioactivity at time t relative to that at zero time (*i.e.* immediately after adding ATP). Data are means \pm SEM from 2 experiments with the number of assays in parentheses.

Figure 5.11 Effect of incubating mitochondria in the presence or absence of palmitoyl carnitine on rate of release of ^{32}P from ^{32}P phosphorylated PDH complex

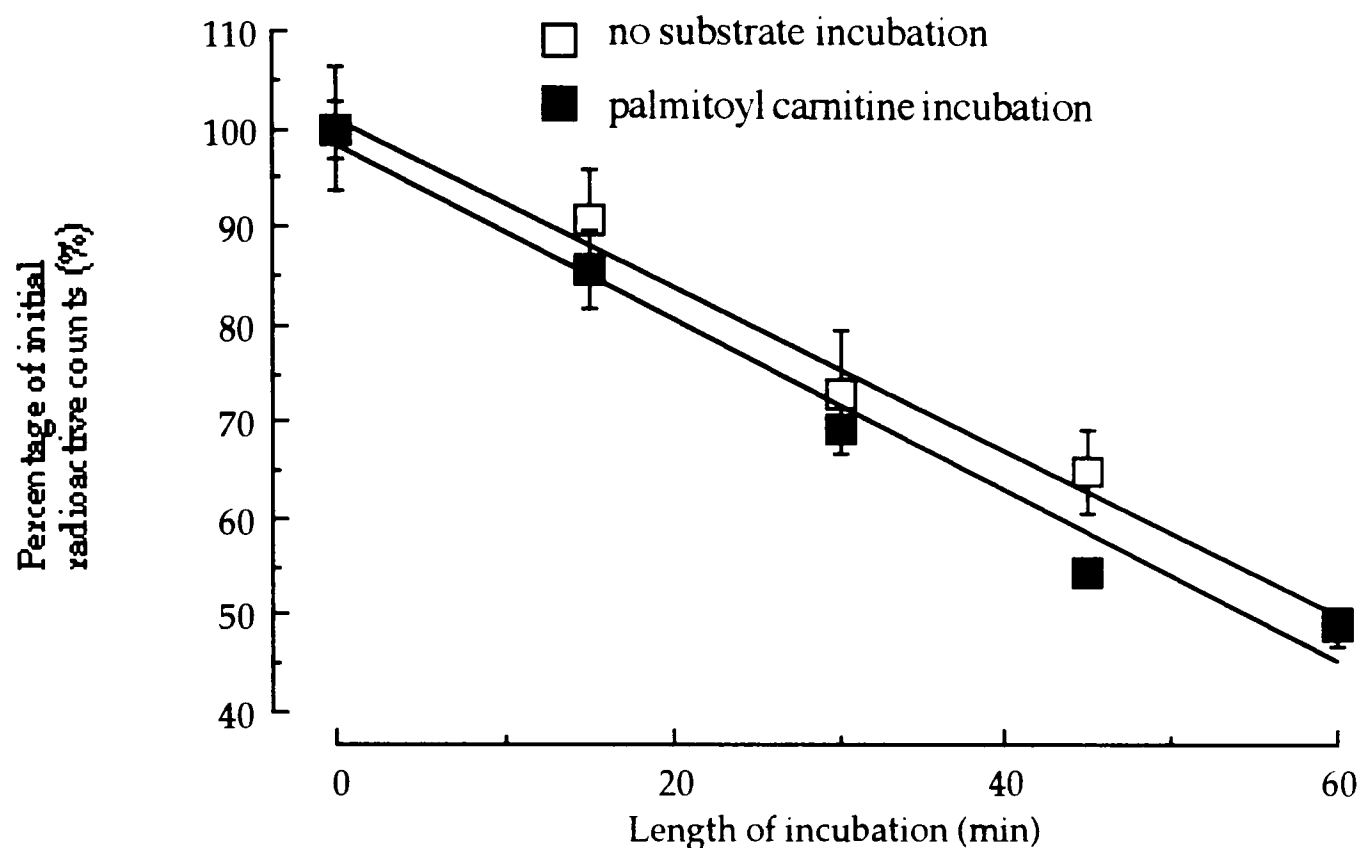

Heart mitochondria, prepared from fed rats, were preincubated in KCl medium for 10min at 30°C to deplete mitochondria of endogenous substrates. After measuring PDH complex activity in an extracted sample mitochondria were incubated (200mU-PDH complex/ml) with KCl medium \pm 50 μM -palmitoyl-L-carnitine/ 0.1%-fatty acid free BSA /0.5mM-L-malate for 15min at 30°C and aerated every 5min. After centrifugation (MSE 18; 10 000, 7-8min, 4°C), pellets were resuspended and incubated with KCl medium/10 μM -CCCP for 30min at 30°C to reactivate PDH complex. Mitochondria were aliquoted into cryotubes and centrifuged (eppendorf centrifuge) and pellets were frozen in liquid nitrogen. Pellets were thawed and resuspended with extraction buffer (50mM-KH₂PO₄/10mM-EGTA/2mM-DTT/1mM-MgSO₄/0.5mM-TLCK/1mM-benzamidine/10 μM -leupeptin, pH 7.0 containing 50 μg -oligomycin B/ml) and frozen and thawed x 2.

Rates of ATP dependent inactivation were measured to calculate the length of time needed to effect approximately 90 % inactivation of PDH complex by phosphorylation. Samples were diluted to 2U-initial PDH complex/ml with extraction buffer and divided into two equal portions. To one portion was added 10mM-[γ - ^{32}P]ATP to a final concentration of 1mM and the equivalent volume of H₂O was added to the other. Following incubation at 30°C (length of time dependent upon nutritional status and mitochondrial incubation medium), PDH phosphatase assay buffer (0.1m-Tris-HCl/2.5mM-CaCl₂/125mM-MgCl₂/5mM-EDTA, pH 8.4) and ADP-pyruvate mix were added. Final concentrations of kinase inhibitors were 1.42mM-ADP and 0.95mM-pyruvate. Extracts were incubated at 30°C for up to 60min during which samples were taken periodically and pipetted onto paper squares. Paper squares were processed and the radioactivity counted. The results are expressed as the percentage of initial protein bound d.p.m. remaining at time *t* (*i.e.* from the point of addition of PDH phosphatase buffer containing PDH kinase inhibitors).

carnitine incubation of rat heart mitochondria had no effect on the rate of release of radioactive phosphate which was the same result as that obtained with the equivalent experiments where rates of reactivation were measured under the similar conditions.)

Palmitoyl carnitine thus had no significant effect on rates of reactivation of PDHP or release of ^{32}P incorporated into ^{32}P phosphorylated PDH complex in fed rats.

20 Effect of PDH phosphatase inhibitors on the rate of reactivation of phosphorylated PDH complex in extracts of mitochondria previously incubated \pm palmitoyl carnitine.

The results in the preceding section provided some evidence that reactivation of PDH complex following inactivation by ATP in extracts of mitochondria incubated \pm palmitoyl carnitine) is effected by PDH phosphatase. In this section further evidence for this conclusion is provided by studying the effects of a known inhibitor of PDH phosphatase (F^-); and of a known activator of PDH phosphatase (Ca^{2+}).

PDH complex was inactivated with 0.5mM-ATP in extracts of mitochondria following incubation \pm palmitoyl carnitine. Incubation conditions were changed in favour of dephosphorylation altered by the addition of PDH phosphatase buffer containing PDH kinase inhibitors (1.42mM-ADP, 0.95mM-pyruvate), PDH phosphatase activators $\text{Mg}^{2+} \pm \text{Ca}^{2+}$ (the latter was excluded in some incubations), and PDH kinase inhibitors (ADP and pyruvate, final concentrations 1.42mM and 0.95mM respectively). When added PDH phosphatase inhibitor NaF was present at a final concentration of 20mM.

The results are given in Fig. 5.12. The highest rates of reactivation of PDH complex during incubation in PDH phosphatase mix were observed with extracts prepared from mitochondria \pm palmitoyl-L-carnitine/L-malate (no significant difference between them). Fluoride ions were equally effective at diminishing reactivation by PDH phosphatase with extracts from mitochondria incubated in the presence or absence of palmitoyl-L-carnitine/ L-malate ($P < 0.001$ for each decrease in activity). Omission of Ca^{2+} from phosphatase assay buffer decreased the rate of reactivation with extracts of mitochondria incubated with palmitoyl

Figure 5.12 Effect of PDH phosphatase inhibitors and of omission of Ca^{2+} on the rate of reactivation of PDH complex inactivated by phosphorylation

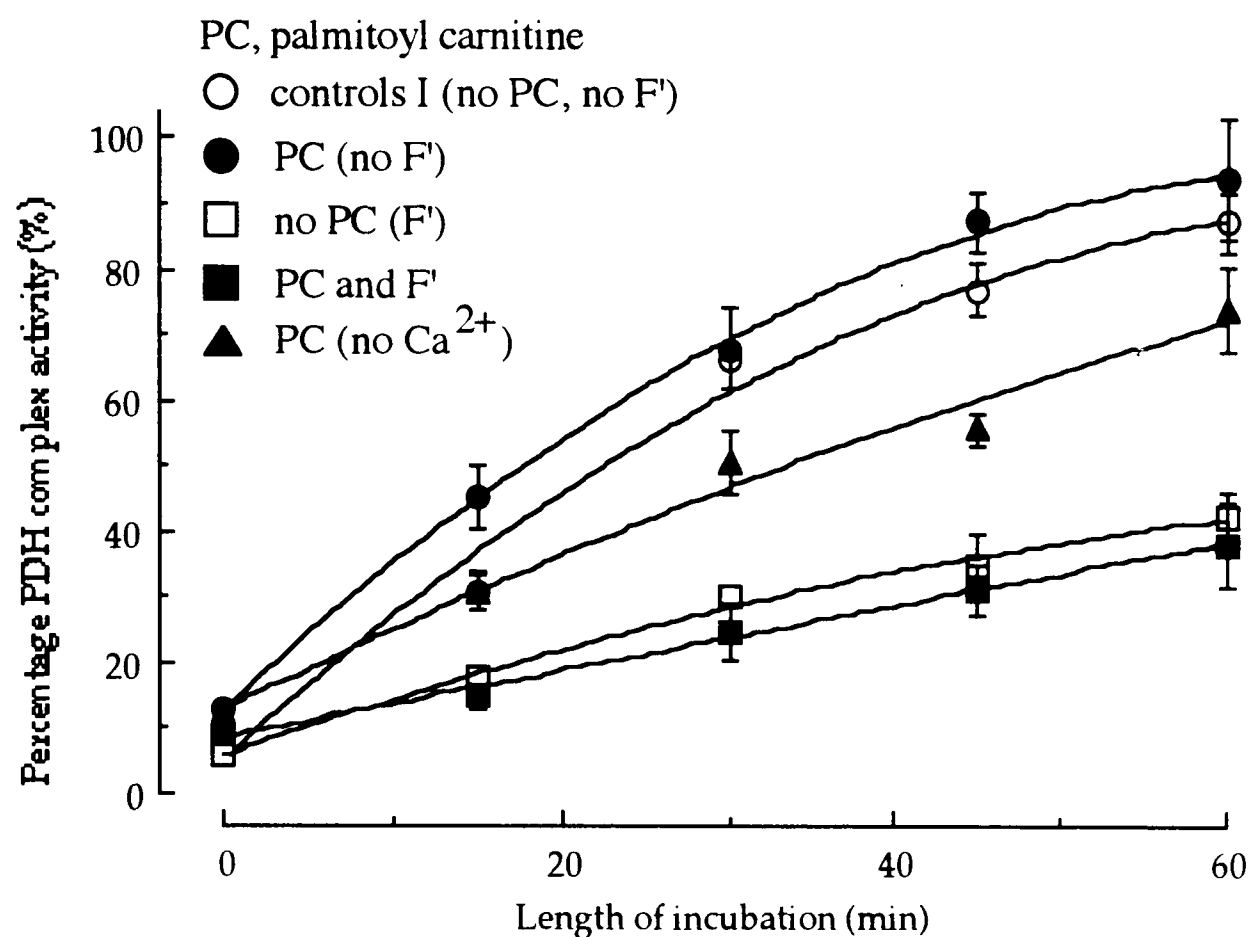

Heart mitochondria were preincubated in KCl medium for 10min at 30°C to reactivate PDH complex. After assay on an extracted sampled mitochondria were incubated at 200mU PDH complex /ml with KCl medium $\pm 50\mu\text{M}$ -palmitoyl-L-carnitine/ 0.1%-fatty acid free BSA/ 0.5mM-L-malate for 15min at 30°C (water bath) and aerated every 5min. Incubates were centrifuged (MSE 18; 10 000g ,7-8min, 4°C) and pellets resuspended and incubated with KCl medium/10 μM -CCCP for 30min at 30°C to reactivate PDH complex, aliquoted into cryotubes, centrifuged (ependorf centrifuge) and pellets frozen (liquid N_2). Pellets were thawed, resuspended in 50mM- KH_2PO_4 /10mM-EGTA/2mM-DTT/1mM- MgCl_2 /0.5mM-TLCK/1mM-benzamidine/10 μM -leupeptin, pH 7.0 containing 50 μg -oligomycin B/ml, and frozen and thawed x2.

Rates of ATP dependent inactivation of PDH complex were measured to calculate the time needed to effect 90% inactivation by ATP. Samples were diluted to 2U-initial PDH complex/ml with extraction buffer and divided into two equal portions. To one portion was added 10mM-ATP to a concentration of 1mM; to the other H_2O . Following incubation at 30°C for the calculated length of time to effect 90 per cent inactivation by phosphorylation, PDH phosphatase assay buffer (0.1m-Tris-HCl/2.5mM- CaCl_2 /125mM- MgCl_2 /5mM-EDTA, pH 8.4) $\pm 20\text{mM}$ -NaF or $\pm \text{CaCl}_2$ was added together with ADP-pyruvate mix (the final concentrations were 1.42mM-ADP and 0.95mM-pyruvate). Extracts were incubated at 30°C for up to 60min during which samples were taken periodically and assayed for PDH complex activity. Results are expressed as $100 \times [(\text{PDH complex activity at time } t) / (\text{PDH complex activity prior to phosphorylation with ATP})]$. $P < 0.01$ for effect of fluoride or of omission of Ca^{2+} .

carnitine, but significant differences from controls were found only at 15 ($P<0.05$) and 45min ($P<0.01$). The effect of Ca^{2+} omission was smaller than that effected by F^- .

These results appear to show no effect of incubation with palmitoyl carnitine on endogenous mitochondrial PDH phosphatase activity.

CONCLUSIONS

The results of studies given in this chapter show that the palmitoyl carnitine effect to increase ATP dependent inactivation of PDH kinase is associated with little or no increase in the rate of incorporation of ^{32}P from $[\gamma\text{-}^{32}\text{P}]\text{ATP}$ into PDH complex in heart mitochondrial extracts from fed or 48h starved rats. Comparison of incorporation of phosphate with the proportion of PDHP complex showed that the effect of palmitoyl carnitine for a given amount of ^{32}P -phosphate doubled the proportion of PDHP. Total incorporation may have been half that reported for fed, 48h starved or alloxan-diabetic rats in the absence of incubation with palmitoyl carnitine.

Consideration had to be given to the possibility that part of the ATP dependent inactivation in extracts of mitochondria might be due to an effect or effects of ATP not mediated by phosphorylation of the PDH complex. Evidence was given here supports the idea that palmitoyl carnitine enhances inactivation through an effect on phosphorylation of site 1 of the complex because of the following. The increased rates of inactivation are phosphorylation dependent because rates of inactivation were not seen with the non-phosphorylating analogue of ATP, AMP-PNP. Studies with known PDH kinase inhibitors show that the effect is related to PDH kinase activity because PDH kinase activities were decreased *pro rata* by ADP plus pyruvate, pyruvate and TPP. Palmitoyl carnitine may not increase phosphorylation of sites 2 and 3, indirectly assessed by measuring rates of reactivation and release of ^{32}P by PDH phosphatase and also using known phosphatase inhibitors. Measurements of the stoichiometries of phosphorylation of the three individual sites is needed to further resolve this question..

The mechanism of activation of PDH kinase with mitochondria from fed rats incubated with palmitoyl carnitine or with extracts of mitochondria from fed rats incubated with palmitoyl-CoA are therefore different from those of starvation. Palmitoyl carnitine in intact mitochondria and palmitoyl-CoA in mitochondrial extracts did not increase rates of incorporation of phosphate into PDH complex whereas starvation increases both the rate of ATP dependent inactivation and the rate of phosphorylation of the complex. Palmitoyl carnitine further increased rates of inactivation and incorporation in palmitoyl carnitine incubated mitochondria from 48h starved

rats. One discrepancy requires further investigation. Measurements of ATP dependent inactivation suggested that effects of starvation and of incubation of mitochondrial extracts with palmitoyl-CoA to increase PDH kinase activity might not be additive and therefore might share a common mechanism. However the results given in this chapter provide no evidence in support of this and this aspect of the study requires further clarification.

The results in this chapter show that the palmitoyl carnitine effect in mitochondria to enhance ATP dependent inactivation of PDH complex is dependent on phosphorylation and that it involves a novel mechanism which halves the stoichiometry of phosphorylation. There are no obvious clues as to how palmitoyl carnitine may alter the interaction between PDH kinase and the PDH complex such that only one alpha chain in the E1 component is available for phosphorylation .

Chapter 6

General Conclusions

GENERAL CONCLUSIONS

My initial studies (chapter 2) were directed towards investigating factors which might regulate triacylglycerol concentration in skeletal muscle. It was known from the work of Denton and Randle (1967) that the concentration of triacylglycerol is increased in rat gastrocnemius muscle in alloxan diabetes and it was considered important to determine the factors that regulate triacylglycerol concentration in muscles. Using the method for longer term culture developed in this laboratory soleus muscle strips were incubated with palmitate *in vitro* and incorporation into triacylglycerol in the muscle strips demonstrated. It was not possible to determine whether incubation with palmitate increased the triacylglycerol concentration significantly because of the large variation between individual muscles. One possible explanation for this unexpectedly large variation between muscle strips was variable contamination with adipocytes as a result of adherent or intrinsic adipose tissue. In view of this uncertainty it was decided not to proceed further with this project.

The activity of pyruvate dehydrogenase (PDH) kinase was known to be increased in heart and skeletal muscles of 48h starved and alloxan diabetic rats. Experiments in tissue culture had shown that fatty acids increase PDH kinase activities in hepatocytes, cardiac myocytes and soleus muscle strips. The carnitine acyltransferase system was known to be involved as Etomoxir prevented the fatty acid enhancement of hepatic PDH kinase activity. The concentrations of acyl carnitine are known to be increased in hearts of starved or diabetic rat hearts. In studies described in Chapter 3 it is known that incubation of heart mitochondria from fed normal rats with palmitoyl carnitine increased rates of ATP-dependent inactivation of PDH complex. Incubation with succinate, acetyl carnitine (5mM but not 0.5mM) + malate, α -ketoglutarate + malate, α -ketoisocaproate + malate but not pyruvate + malate also increased rates of ATP-dependent inactivation of the complex but to a lesser extent. The increases were stable in that they persisted through incubation of mitochondria with uncoupler (CCCP) and extraction by repeated freezing and thawing. Therefore, the mechanism of activation of the PDH kinase by

palmitoyl carnitine is unlikely to be dependent upon the continued presence of metabolisable substrates such as acyl-CoA or NADH. Palmitoyl carnitine incubation of isolated heart mitochondria from starved rats further increased rates of ATP-dependent inactivation of PDH complex over and above that effected by starvation *in vivo* and the increase was comparable with that observed with fed mitochondria. This suggests that the mechanisms of activation by starvation and by palmitoyl-CoA are distinct.

In studies described in Chapter 4 it is shown that incubation of extracts of heart mitochondria from fed rats with palmitoyl-CoA increased rates of ATP-dependent inactivation of PDH complex. This effect of palmitoyl-CoA was not observed in extracts of heart mitochondria from starved rats. One possible explanation of this difference between fed and starved is that the mechanism of activation of PDH kinase effected *in vivo* by starvation may not involve that effected *in vitro* by palmitoyl-CoA incubation of mitochondrial extracts. The results of experiments in which isolated mitochondria were incubated with palmitoyl carnitine and extracts prepared from these mitochondria were incubated with palmitoyl-CoA indicated that the individual mechanisms may not be identical.

In studies in Chapter 5 it is shown that rates of incorporation of ^{32}P from $[\gamma\text{-}^{32}\text{P}]\text{ATP}$ into PDH complex were not increased by incubation of rat heart mitochondria with palmitoyl carnitine nor by incubation of rat heart mitochondrial extracts with palmitoyl-CoA. It was therefore important to attempt to show that ATP-dependent inactivation involved phosphorylation even though ^{32}P incorporation was not accelerated. Points of evidence included the demonstration that a non-phosphorylating analogue of ATP (adenylylimidodiphosphate) could not substitute for ATP; incubation with known PDH kinase inhibitors decreases rates of inactivation *pro rata*; and rates of reactivation were appropriately affected by incubation with known activators or inhibitors of PDH phosphatase. It would appear that the stoichiometry of inactivation by phosphorylation (*i.e.* nmol ^{32}P incorporated per unit of PDH complex inactivated) was approximately halved by incubation of heart mitochondria with palmitoyl

carnitine. This is in contradistinction with the effect of starvation which increases rates of both ATP-dependent inactivation of, and incorporation of ^{32}P from $[\gamma\text{-}^{32}\text{P}]\text{ATP}$ into, PDH complex (Hutson and Randle, 1978). One possibility is that incubation of heart mitochondria with palmitoyl carnitine changes the stoichiometry of inactivation by phosphorylation from 2nmolP to 1nmolP per mol of pyruvate dehydrogenase ($\text{E1 } \alpha_2\beta_2$) inactivated. It is known that the stoichiometry of inactivation of purified pig heart PDH by phosphorylation is half site [*i.e.* 1molP per mol of ($\text{E1 } \alpha_2\beta_2$) inactivated]. There is some earlier evidence for a higher ration of nmolP incorporated per unite of complex inactivated with rat heart complex as compared with pig heart complex - complete phosphorylation 1.32nmolP incorporated per unit of complex inactivated (pig) as compared with 2.25nmolP/unite of complex inactivated (rat) (Sale and Randle, 1980). One possible reason for this difference is possibly the stressful conditions of the slaughter house through which accelerated lipolysis might be expected to increase cytoplasmic fatty acyl carnitine and mitochondrial fatty acyl-CoA. This effect may therefore be unrelated to the effects of starvation or diabetes. Precise information is lacking regarding phosphorylation site occupancies in rat heart PDH complex in the experiments described in this thesis and this is the focus of future work. Establishment of the precise stoichiometry of phosphorylation (*i.e.* whether $\alpha\text{P}\alpha\beta_2$ or $\alpha_2\text{P}_2\beta_2$ in purified rat heart complex is required.

APPENDIX

Composition of Medium 199, Earle's salts
(Information has been taken from manufacturer's data sheet.)

Amino acids		Inorganic salts	
DL- α -Alanine	0.56mM	CaCl ₂ (anhydrous)	1.81mM
L-Arginine HCl	0.33mM	Fe(NO ₃) ₃ .9H ₂ O	1.77mM
DL-Asparatic acid	0.45mM	KCl	5.41mM
L-Cysteine HCl.H ₂ O	0.63 μ M	MgSO ₄ .7H ₂ O	0.81mM
L-Cysteine	83.0 μ M	NaCl	117mM
DL-Glutamic acid	1.02mM	NaHCO ₃	26.2mM
L-Glutamine	0.68mM	NaH ₂ PO ₄ .H ₂ O	1.01mM
Glycine	0.67mM	Other compounds	
L-Histidine HCl.H ₂ O	95.0 μ M	Adenine sulphate	27.2 μ M
L-Hydroxyproline	76.0 μ M	Adenosine triphosphate (disodium salt)	1.65 μ M
DL-Isoleucine	0.31mM	Adenylic acid	0.50 μ M
DL-Leucine	0.92mM	Cholesterol	0.50 μ M
L-Lysine HCl	0.38mM	Deoxyribose	3.73 μ M
DL-Methionine	0.20mM	Glucose	5.56mM
DL-Phenylalanine	0.30mM	Glutathione	0.16 μ M
L-Proline	0.35mM	Guanine HCl (Free base)	1.60 μ M
DL-Serine	0.48mM	Hypoxanthine	2.20 μ M
DL-Threonine	0.50mM	Phenol Red	54.6 μ M
DL-Tryptophan	98.0 μ M	D-Ribose	3.33 μ M
L-Tyrosine	0.22mM	Sodium acetate	0.61mM
DL-Valine	0.43mM	Thymine	2.38 μ M
		Tween 80®	20mg/l
Vitamins		Uracil	2.68 μ M
Ascorbic acid	0.25 μ M	Xanthine	1.97 μ M
α -Tocopherol phosphate	19.2nM		
Biotin	41.0nM		
Calciferol	0.25 μ M		
D-Ca pantothenate	21.0nM		
Choline chloride	3.5 μ M		
Folic acid	22.7nM		
i-inositol	0.28 μ M		
Menadione	58.1nM		
Niacin	0.20 μ M		
Niacinamide	0.20 μ M		
Para-aminobenzoic acid	0.37 μ M		
Pyridoxial	26.6nM		
Thiamine HCl	29.6nM		
Vitamin A	0.19 μ M		

BIBLIOGRAPHY

- Abumrad NA, Tepperman HM and Tepperman J (1980) *J Lipid Res* **21** 156-161
- Ailhaud G (1990) *Clin Biochem* **23** 343-347
- Ali MS, Roche TE and Patel MS (1993) *J Biol Chem* **268** 22353-22356
- Ali MS, Shenoy BC, Eswaran D, Andersson LA, Roche TE and Patel MS (1995) *J Biol Chem* **270** 4570-4574
- Assimacopoulos-Jeannet F, McCormack JG, Prentki M, Jeanrenaud B and Denton RM (1982) *Arch Biochem Biophys* **148** 343-358
- Baht HS and Saggerson ED (1988) *Biochem J* **250** 325-333
- Barrera CR, Namihira G, Hamilton L, Munk P, Eley MH, Linn TC and Reed LJ (1972) *Arch Biochem Biophys* **148** 343-358
- Bates EJ and Saggerson ED (1979) *Biochem J* **182** 751-762
- Baxter MA, Goheer MA and Coore HG (1979) *FEBS Letts* **97** 21-31
- Baxter MA and Coore HG (1978) *Biochem J* **174** 553-561
- Beaucamp K, Bergemeyer HU and Beutler H-O (1974) In *Methods of Enzymatic Analysis* (Bergemeyer HU ed) Vol 1 pp 523-556 Acad Press Inc NY and Lond
- Bernier M, Laird DM and Lane MD (1987) *Proc Natl Acad Sci USA* **84** 1844-1888
- Berry MN, Phillips JW, Henly DC and Clark DC (1993) *FEBS Lett* **319** 26-30
- Berry MN, Williamson DH and Wilson BM (1965) *Biochem J* **94** 17C-19C
- Bianchi A, Evans JL, Iverson AJ, Nordlund AC, Watts TD, Hers LA (1990) *J Biol Chem* **265** 1502-1509
- Binnert C, Pachlaudi C, Beylot M, Croset M, Cohen P, Riou JP and Laville M (1996) *Am J Physiol* **270** E445-E450
- Blackshear PJ, Holloway PAH and Alberti KGMM (1974) *Biochem J* **142** 447-556
- Blackshear PJ, Holloway PAH and Alberti KGMM (1975) *Biochem J* **146** 279-286
- Bligh and Dyer (1959) *Can J Biochem and Physiol* **37** 911
- Borensztajn J and Robinson DS (1970) *J Lipid Res* **11** 111-117

- Bradford MM (1976) *Anal Biochem* **72** 248-254
- Braun JEA and Severson DL (1991) *Proc Natl Acad Sci USA* **88** 2254-2258
- Braun JEA and Severson DL (1992) *Biochem J* **287** 337-347
- Bremer J (1966) *Biochim Biophys Acta* **116** 1-11
- Brindley DN (1984) *Prog Lipid Res* **23** 115-133
- Brindley DN (1988) in *Phosphatidate Phosphohydrolase Volume I* (D Brindley ed) CRC Press pp 21-77
- Bringolf M, Zaragoza N, Rivier D and Felber JP (1972) **26** 360-367
- Brookfield DE, Green J, Ali ST, Machado RS and Guest JR (1991) *FEBS Lett* **295** 13-16
- Brownsey RW and Brunt RV (1977) *Clin Sci Mol Med* **53** 513-521
- Bucolo G and David H (1972) *Scand J Clin Lab Invest* 29 Suppl 126, Abstr 3,19
- Bucolo G and David H (1973) *Clin Chem* **195** 476-482
- Burges RA, Butt DW and Baggaley A (1969) *Biochem J* **109** 38-39P
- Cahill GF and Owen OE (1968) *Carbohydr Metab and its Disorders* **1** 497-518
- Camps L, Reina M, Llobera M, Vilaró S and Olivecrona T (1990) *Am J Physiol* **258** C673-C681
- Carling D, Zammit VA and Hardie DG (1987) *FEBS Lett* **223** 217-222
- Carlson LA, Liljedahl S and Wirsen C (1965) *Acta Med Scand* **178** 81
- Cate RL and Roche TE (1978) *J Biol Chem* **253** 496-503
- Caterson ID, Fuller SJ and Randle PJ (1982) *Biochem J* **208** 53-60
- Chan BL, Lisanti MP, Rodriguez-Boulan E and Saltiel AR (1988) *Science* **241** 1670-1672
- Chappell JB and Hansford RG (1978) In *Subcellular components* 2nd ed (Birnie GD ed) pp77
Butterworth London
- Chen RF (1967) *J Biol Chem* **242** 173-181
- Chen Y-DI, Howard J, Huang V, Kraemer FB and Reaven GM (1980) *Diabetes* **29** 643-647
- Chernick SS (1969) No 58 Determination of glycerol in acyl glycerols In: *Methods in Enzymology* (Colowick SP, Kaplan NO, Lowenstein JM eds), vol 14 Lipids, pp 627-630, NY Academic Press

-
- Christiansen DR, Kilsheimer GS, Pettett G, Paradise R and Ashmore J (1969) *Adv Enz Reg* **7** 71-82
- Cohen P (1989) *Ann Rev Biochem* **58** 453-508
- Cooper RH, Randle PJ and Denton RM (1974) *Biochem J* **143** 625-641
- Cooper RH, Randle PJ and Denton RM (1975) *Nature* **257** 808-809
- Coore HG, Denton RM, Martin BR and Randle PJ (1971) *Biochem J* **125** 115-127
- Coore HG, Denton RM, Martin BR and Randle PJ (1971) *Biochem J* **143** 625-641
- Corbin JD and Reiman EM (1974) In *Methods in Enzymology* (Hardman JG, O'Malley BW eds) Vol 38 pp287-290
- Cori CF and Cori GT (1931-1932) *J Biol Chem* **94** 581-591
- Cornell R and MacLennan DH (1985) *Biochim Biophys Acta* **821** 97-105
- Corton, Gillespie, Hawley and Hardie (1995) *Eur J Biochem* **229** 558-565
- Crass ME (1972) *Biochim Biophys Acta* **280** 71-81
- Crass ME (1977) *Fed Proc* **36** 1995-1999
- Crass ME and Pieper GM (1975) *Am J Physiol* **229** 885-889
- Crass ME, McCaskill ES, Shipp JC and Murphy VK (1971) *Am J Physiol* **220** 428-435
- Crass ME, Shipp JC and Pieper GM (1975) *Am J Physiol* **228** 618-627
- Crettaz M, Prentki M, Zaninetti D, Jeanrenaud B (1980) *Biochem J* **186** 525-534
- Crompton M, Kessar P and Al-Nasser I (1983) *Biochem J* **216** 333
- Cuendet GS, Loten EG and Renold AE (1975) *Diabetologia* **11** 336
- Cuendet GS, Loten EG, Jeanrenaud B, Renold AE (1976) *J Clin Invest* **58** 1078-1088
- Cupp M, Bensadoun A and Melford K (1987) *J Biol Chem* **262** 6383-6388
- Damuni Z and Reed LJ (1987) *J Bio Chem* **262** 5135-5138
- Damuni Z, Humphreys JS and Reed LJ (1984) *Biochem Biophys Res Commun* **124** 95-99
- Dardel F, Davis AL, Lane ED and Perham RN (1993) *J Mol Biol* **229** 1037-1048
- Dardel F, Packman LC and Perham RN (1990) *FEBS Lett* **264** 206-210
- Davies SP, Carling D and Hardie DG (1989) *Eur J Biochem* **186** 123-128
- Davis PF, Pettit FH and Reed LJ (1977) *Biochem Biophys Res Commun* **75** 541-549

-
- de Groot, Willemsen, Coumans, Bilsen and Vusse (1989) *Biochim Biophys Acta* **1006** 111-115
- DeFronzo RA (1988) *Diabetes* **37** 667-687
- del Carmen Vila MC and Farese RV (1991) *Arch Biochem Biophys* **284** 366-368
- del Carmen Vila MC, Milligan G, Standaert ML and Farese RV (1990) *Biochemistry* **29** 8735-8740
- DeMarcucci OL and Lindsay JG (1985) *Eur J Biochem* **149** 641-648
- Denton RM and Randle PJ (1967a) *Biochem J* **104** 416-422
- Denton RM and Randle PJ (1967b) *Biochem J* **104** 423-434
- Denton RM, McCormack JG and Marshall SE (1984) **217** 441-452
- Denton RM, Randle PJ, Bridges BJ, Cooper RH, Kerbey AL, Pask HT, Severson DL, Stansbie D and Whitehouse S (1975) *Mol Cell Biochem* **9** 27-53
- Denton RM, Randle PJ and Martin BR (1972) *Biochem* **128** 161-163
- Denton RM, Midgley PJ, Rutter W, Thomas AP and McCormack JG (1989) *Ann NY Acad Sci* **573** 285-296
- Denyer GS, Kerbey AL and Randle PJ (1986) *Biochem J* **239** 347-354
- Doolittle MH, Ben-Zee O, Elovson J, Martin D and Kirchgessner TG (1990) *J Biol Chem* **265** 4570-4577
- Drury DR and Wick AN (1953) *Ciba Found Colloq Endocrinol* **6** 224-230
- Eckel RH (1989) *New Engl J Med* **320** 1060-1068
- Eggstein M and Kuhlmann E (1974) Triglyceride and Glycerol, Determination after alkaline hydrolysis In *Methods of Enzymatic Analysis* pp1825-1829
- Falholt K, Jensen I, Lindkaer Jensen S, Mortensen H, Volund A, Heding LG, 1988
- Farese RV, Standaert ML, Yamada K, Huang LC, Zhang C, Cooper DR, Wang Z, Yang Y, Suzuki S, Toyota T et al (1994) *Proc Natl Acad Sci* **91** 11040-11044
- Fatania HR, Vary TC and Randle PJ (1986) *Biochem J* **234** 233-236
- Felig P and Kiovisto V (1979) Recent advances in body fuel metabolism In 'Contemporary Metabolism', Volume I ed Freinkel N Plenum, New York pp 359-384/ *Contemp Metab* **1** 359-384

- Ferrannini E, Barrett EJ, Bevilacqua S and DeFronzo RA (1983) *J Clin Invest* **72** 1737-1747
- Folch J, Lees M and Sloane-Stanley GH (1957) *J Biol Chem* **226** 497-509
- Fossati P and Prencipe L (1982) *Clin Chem* **2810** 2077-2080
- Fox JA, Soliz NM and Saltiel A (1987) *Proc Natl Acad Sci USA* **84** 2663-2667
- Frayn KN and Maycock (1980) *J Lipid Res* **21** 139-144
- Freeman and Mangiapane (1989) *Biochem J* **263** 589-595
- Fried SK, Turkenkopf IJ, Goldberg IJ, Doolittle MH, Kirchgessner TG, Schotz MC Johnson PR and Greenwood MRC (1991) *Am J Physiol* **261** E653-E660
- Fuller SJ (1984) DPhil Thesis, Oxford
- Fuller SJ and Randle PJ (1984) *Biochem J* **219** 635-646
- Garfinkel AS and Schotz MC (1987) in *Lipoproteins* (Gotto AM Jr, ed) pp 335-357 Elsevier, Amsterdam
- Garfinkel AS, Kempner ES, Ben-Zeev O, Nikazy J, James SJ and Schotz MC (1983) *J Lipid Res* **24** 775-780
- Garland PB and Randle PJ (1964a) *Biochem J* **91** 6C 7C
- Garland PB and Randle PJ (1964b) *Biochem J* **93** 678 687
- Garland PB and Randle PJ (1962) *Nature* **196** 987-988
- Garland PB, Newsholme EA and Randle PJ (1964) *Biochem J* **93**
- Garland PB, Newsholme EA and Randle PJ (1962) *Nature* **195** 381 383
- Garland PB, Randle PJ and Newsholme EA (1963) *Nature* **200** 169 170
- Gartner SL and Vahouny GV (1973) *Proc Soc Exp Biol Med* **143** 556 560
- Garton AJ and Yeaman SJ (1990) *Eur J Biochem* **191** 245-250
- Garton AJ, Campbell DG, Carling D, Hardie DG, Colbran RJ and Yeaman SJ (1989) *Eur J Biochem* **179** 249-254
- Garton AJ, Campbell DG, Cohen P and Yeaman SJ (1988) *FEBS Lett* 222968-22972
- Gawler D and Houslay M (1987) *FEBS Letts* **216** 94-98
- Giralt M, Martin I, Vilaró S, Villarroya E, Mampel T, Iglesias R and Viñas O (1990) *Biochim Biophys Acta* **1048** 270-273

- Glock GE and McLean P (1954) *Biochem J* **56** 171-175
- Gordon RS and Cherkes A (1956) *J Clin Invest* **35** 206-212
- Gornall HG, Bardawill CJ and David MM (1949) *J Biol Chem* **177** 751-766
- Graham LD, Packman LC and Perham RN (1989) *Biochemistry* **28** 1574-1581
- Green MH and Landau BR (1965) *Arch Biochem Biophys* **111** 569-575
- Griffiths EJ and Brunt RV (1990) *J Mol Cell Cardiol* **22** 303-310
- Grundleger ML and Thenen SW (1982) *Diabetes* **31** 232-237
- Gunsalus IC (1954) In *The Mechanism of Enzyme Action* (McElroy WD and Glass B, eds) John Hopkins Press Baltimore pp545-580
- Haagsman HP, de Haas CG, Geelen MJ and van Golde LM (1982) *J Biol Chem* **257** 525-528
- Hackert ML (1990) *J Biol Chem* **265** 8971-8974
- Hagg SA, Taylor SI and Ruderman NB (1976) *Biochem J* **158** 203-210
- Hall GM, Young C and Holdcroft A et al 1978 *Anaesthesia* **33** 924-930
- Hamosh M and Hamosh P (1983) *Mol Aspects Med* **6** 199-189
- Hansford RG (1976) *J Biol Chem* **251** 5483-5489
- Harris RA, Popov KM, Shimomura Y, Zhao Y, Jaskiewicz J, Namaumi N and Suzuki M (1992) *Advan Enzyme Regul* **32** 267-284
- Hawkins RF, Borgers A and Perham RN (1989) *FEBS Lett* **255** 77-82
- Hayakawa T, Kanzaki T, Kitamura T, Kukuyoshi Y, Sakwai Y, Koike K, Svenatsu T and Koike M (1969) *J Biol Chem* **244** 3660-3670
- Heathers GP, Al-Muhtaseb and Brunt RV (1985) *J Mol Cell Cardiol* **17** 785-796
- Heathers GP and Brunt RV (1985) *J Mol Cell Cardiol* **17** 907-916
- Hennig G, Loffler G and Wieland OH (1975) *FEBS Letts* **59** 142-145
- Her S and Van Schaftingen E (1982) *Biochem J* **206** 1-12
- Hiraoka T, DeBuysere M and Olson MS (1980) *J Biol Chem* **255** 7604-7609
- Holdsworth JE and Ratledge C (1991) *Lipids* **26** 111-118
- Holm C, Kirchgessner TG, Svenson KL, Frenrikson G, Nilsson S, Miller CG, Shively JE, Heinzmann C, Sparkes RS, Mohandas T, Lusi AJ, Belfrage P and Schotz MC (1988)

Science **241** 1503-1506

Holness MJ and Sugden MC (1987) **241** 421-425

Holness MJ and Sugden MC (1989) *Biochem J* **258** 529-533

Holness MJ and Sugden MC (1990) *Biochem Soc Trans* **18** 591-592

Hopp JF and Palmer WK (1991) *Metabolism* **40** 223-225

Hron WT, Jestnok GJ, Lombardo YB, Menahan LA and Lech JJ (1977) *J Mol Cell Cardiol* **9**
733-748

Hron WT, Menahan LA and Lech JJ (1978) *J Mol Cell Cardiol* **10** 161-174

Hucho F, Randall DD, Roche TE, Burgett MW, Pelley JW and Reed LJ (1972) *Arch Biochem
Biophys* **151** 328-340

Hue L, Maisin L and Rider MH (1988) *Biochem J* **251** 541-545

Hughes WA and Denton RM (1976) *Nature* **264** 471-473

Hughes WA, Brownsey RW and Denton RM (1980) *Biochem J* **192** 496-481

Hutson NJ and Randle PJ (1978) *FEBS Letts* **92** 73-76

Illingworth JA and Mullings R (1976) *Biochem Soc Trans* **4** 291-292

Itoh T and Quastel JH (1970) *biochem J* **116** 641-655

Iverius PH and Ostlund-Lindqvist AM (1976) *J Biol Chem* **251** 7791-7795

Jamal Z, Martin A, Gomez-Muñoz A and Brindley DN (1991) *J Biol Chem* **266** 2988-2996

James DE, Jenkins AB and Kreagen EW (1985) *Am J Physiol* **248** E567-E574

Jarett L, Kiechle FL and Parker JC (1982) *Fed Proc Fed Am Soc Exp Biol* **41** 2736-2741

Jensen DR, Bessesen DH, Etienne J, Eckel RH and Neville MC (1991) *J Lipid Res* **32** 733-742

Jepson CA and Yeaman SJ (1992) *FEBS Lett* **310** 197-200

Jestnok GJ, Calvert DN and Lech JJ (1977) *J Pharmacol Exp Ther* **200** 187-194

Jilka JM, Rahmatullah M, Kazemi M and Roche TE (1986) *J Biol Chem* **261** 1858-1867

Jodalen H, Lie R and Rotevtan S (1982) *Res Exp Med* **181** 239-244

Johnson AB, Argyraki M, Thow JC, Cooper BG, Fulcher G and Taylor R (1992) *Clinical
Science* **82** 219-226

Jones BS, Yeaman SJ, Sugden MC and Holness MJ (1992) *Biochim Biophys Acta* **1134** 164-

-
- Jungas RL (1970) *Endocrinology* **86** 1368-1375
- Jungas RL (1971) *Metabolism* **20** 43-53
- Jungas RL and Ball EG (1963) *Biochemistry* **2** 383-388
- Jungas RL and Ball EG (1962) *Fed Pro* **21** 202
- Kako KJ, Vasdev SC and Zaror-Behrens G (1976) *Recent Adv Stud Cardiac Struct Metab* **11** 369-77
- Karwatowska-Krynska E and Beresewicz A (1983) *J Mol Cell Cardiol* **15** 523-536
- Kenno KA and Severson DL (1985) *Am J Physiol* **249** H1024-H1030
- Kerbey AL and Randle PJ (1979) *FEBS Letts* **108** 485-488
- Kerbey AL and Randle PJ (1981) *FEBS Letts* **127** 188-192
- Kerbey AL and Randle PJ (1982) *Biochem J* **206** 103-111
- Kerbey AL and Randle PJ (1985) *Biochem J* **231** 523-529
- Kerbey AL, Radcliffe PM and Randle PJ (1977) *Biochem J* **164** 509-519
- Kerbey AL, Radcliffe PM, Sugden PH and Randle PJ (1979) *Biochem J* **181** 427-443
- Kerbey AL, Randle PJ and Kearns A (1981) *Biochem J* **206** 103-111
- Kerbey AL, Randle PJ, Cooper RH, Whitehouse S, Pask HT and Denton RM (1976) *Biochem J* **154** 327-348
- Kerbey AL, Richardson J and Randle, PJ (1981) *Biochem J* **195** 51-59
- Klotsch SG and McNamara JR (1990) *Clin Chem* **369** 1605-1613
- Koike M, Reed LJ and Cornell WR (1963) *J Biol Chem* **238** 30-39
- Kraegan EW, James DE, Storlien LH, Burleigh KM and Chisholm DJ (1986) *Diabetologia*
- Krebs HA and Henseleit K (1932) *Hopee-Seyler's Z Physiol Chem* **210** 33-36
- Kreisberg RA (1966) *Am J Physiol* **210** 379-384
- Kreisberg RA (1966) *Am J Physiol* **210** 385-389
- Kryski A, Kenno KA and Severson DL (1985) *Am J Physiol* **248** H208-H216
- Krzentowski G, Pirany F, Pallikarakis N, Luyckx AS, Luyckx M, Mosora F and Lefebvre PJ (1981) *Diabetes* **30** 983-988
- Lang H, Polster M and Brandsch R (1991) *Eur J Biochem* **198** 793-799
- Larner RS, Guest JR and Williamson MP (1982) *FEBS Lett* **323** 243-246

-
- Larner J, Cheng K, Schwartz C, Kikuchi K, Tamura S, Creacy S, Dubler R, Galasko G, Pullin C and Katz M (1982) *Recent Prog Horm Res* **38** 511-552
- Larner J, Huang LC, Suzuki S, Tang G, Zhang L, Schwartz CFW, Romero G, Luttrell L and Kennington AS (1989) *Ann of NY Acad Sci* **573** 297-305
- Larsen and Seversen (1990) *Can J Physiol Pharmacol* **68** 1177-1182
- Lawson JE, Behal RH and Reed LJ (1991) *Biochem* **30** 2834-2839
- Lawson JE, Niu X-D, Browning KS, Trong HL, Yan J and Reed LJ (1993) *Biochemistry* **32** 8987-8993
- Lee KU, Lee HK, Koh CS and Min HK (1988) *Diabetologia* **31** 285
- Lefebvre PJ (1985) *Diabetologia* **28** 255-263
- Li L, Gary A, Kazuo O and Roche TE (1992) *Archg Biochem Biophys* **296** 497-504
- Lilley K, Zhang C, Villar-Palasi C, Larner J and Huang L (1992) *Arch biochem Biophys* **296** 170-174
- Linn TC, Pelley FH, Pettit FH, Hucho F, Randall DD and Reed LJ (1972) *Arch Biochem Biophys* **148** 327-342
- Linn TC, Pettit FH and Reed LJ (1969a) *Proc Natl Acad Sci USA* **62** 234-241
- Linn TC, Pettit FH, Hucho F and Reed LJ (1969b) *Proc Natl Acad Sci USA* **64** 227-234
- Liu G and Olivecrona T (1991) *Am J Physiol* **261** H2044-H2050
- Liu S, Baker JC and Roche TE (1995) *J Biol Chem* **270** 793-800
- Lorini M and Ciman M (1962) *Biochem Pharmacol* **11** 823-827
- MaCauley SL and Jarett L (1985) *Arch Biochem Biophys* **237** 142-150
- Maeng CY, Yazdi MA, Niu XD, Lee HY and Reed LJ (1994) *Biochemistry* **33** 13801-13807
- Marchington DR, Kerbey AL and Randle PJ (1990) *Biochem J* **267** 245-247
- Marchington DR, Kerbey AL, Giardina MG, Jones AE and Randle PJ (1989) *Biochem J* **257** 487-491
- Margolis S and Vaughan M (1962) *J Biol Chem* **237** 44
- Marshall SE, McCormack JG and Denton RM (1984) *Biochem J* **214** 249-260
- Martin BR, Denton RM, Pask HT and Randle PJ (1972) *Biochem J* **129** 763-773

- Massey V (1963) *Enzymes* 2nd ed 7 275-306
- McAllister A, Allison SP and Randle PJ (1973) *Biochem J* **134** 1967-1981
- McCormack JG (1985) *Biochem J* **231** 597-608
- McCormack JG and Denton RM (1977) *Biochem J* **166** 627-630
- McCormack JG and Denton RM (1981) *Biochem J* **194** 639-643
- McCormack JG and Denton RM (1984) *Biochem J* **218** 235-247
- McCormack JG and England PJ (1983) *Biochem J* **214** 581-585
- McGowan MW, Artiss J D, Strandbergh DR and Zak B (1983) *Clin Chem* **29** 538-542
- Megraw RE, Dunn ED and Biggs HG (1979) *Clin Chem* **25** 273-278
- Meyer HV, Curchod B, Pahud P, Jequier E and Felber JP (1980) *Biochem Soc Symp Diabetes* **29** 752-756
- Mistry SC, Priestman DA, Kerbey AL and Randle PJ (1991) *Biochem J* **275** 775-779
- Monroy G, Kelker HC and Pullman ME (1973) *J Biol Chem* **248** 2845-2852
- Monroy G, Rola FH and Pullman ME (1972) *J Biol Chem* **247** 6884-6894
- Mullinax JR, Stepp LR, Brown JR and Reed LJ (1985) *Arch Biochem Biophys* **243** 665-669
- Murthy VK, Bauman MD and Shipp JC (1983) *Diabetes* **32** 718-722
- Myrmel T, Forsdahl K and Larsen TS (1992) *J Mol Cell Cardiol* **124** 855-868
- Narabayashi H, Lawson JWR and Uyeda K (1985) *J Biol Chem* **260** 9750-9758
- Neptune EM, Sudduth HC, Brigance WH and Brown JD (1963) *Am J Physiol* **204** 933
- Neptune EM, Sudduth HC, Colodzin M and Reish JJ (1962) *J Lipid Res* **3** 229;
- Newsholme EA (1967) *Clinics in Endocrin Metabolism* **5** 543-578
- Newsholme EA and Leech AR (1983) In *Biochemistry for the Medical Sciences* John Wiley and Sons 77-82
- Newsholme EA and Randle PJ (1961) *Biochem J* **80** 655-662
- Newsholme EA and Randle PJ (1964) *Biochem J* **93** 641-651
- Newsholme EA, Randle PJ and Manchester KL (1962) *Nature* **193** 270-271
- Nicholson CD and Wilke R (1989) *J Auton Pharmac* **9** 159-166
- Nuutila P, Koivisto VA, Knuuti J, Ruotsalainen U, Teras M, Haaparanta M, Bergman J, Solin

-
- O, Voipio-Pulkki L-M, Wegeliu U and Yki-Jarvinen H (1992) *J Clin Invest* **89** 1767-1774
- O'Looney P, Maten MV and Vahouny GV (1983) *J Biol Chem* **258** 12994-13001
- Olsen and Hoeschen (1967) *Biochem J* **103** 796-802
- Ong JM, Kirchgessner TG, Schotz MC and Kern PA (1988) *J Biol Chem* **263** 12933-
- Ono K, Radke GA, Roche TE and Rahmatullah M (1993) *J Biol Chem* **268** 26135-26143
- Opie LH, Evans JR and Shipp JC (1963) *Am J Physiol* **205** 1203
- Oram JE, Bennetch SL and Neely JR (1973) *J Biol Chem* **248** 5299-5309
- Orfali KA, Fryer LG, Holness MJ and Sugden MC (1993) *FEBS Lett* **336** 501-505
- Orfali KA, Fryer LG, Holness MJ and Sugden MC (1995) *J Mol Cell Cardiol* **27** 901-908
- Orth DN and Morgan HE (1962) *J Cell Biol* **15** 509
- Owen OE, Morgan AP, Kemp HG, Sullivan JM, Herrera MH and Cahill GF (1967) *J Clin Invest* **46** 1589-1595
- Paetzke-Brunner I, Schon H and Wieland OH (1978) *FEBS Letts* **92** 307-311
- Palazzo AJ, Malik KU and Weis MT (1991) *Am J Physiol* **260** H604-H612
- Palmer WK, Oscai LB, Bechtel PJ, Fisher GA (1990) *Can J Physiol Pharmacol* **68** 689-93
- Passonneau JV and Lowry OH (1962) *Biochem Biophys Res Commun* **7** 10-15
- Patel MS and Roche TE (1990) *FASEB J* **4** 3224-3233
- Patston PA, Espinal J, Shaw JM and Randle PJ (1986) *Biochem J* **235** 429-434
- Paulson DJ and Crass ME (1982) *Am J Physiol* **242** H1084-H1094
- Pearson DJ, Tubbs PK and Chase JFA (1974) In *Methods of Enzymatic Analysis* (ed HU Bergmeyer) Vol 4 p1758
- Pearson OH, Hastings AB and Bunting H (1949a) *Am J Physiol* **158** 261
- Pearson OH, Hsieh CK, DuTroit CH and Hastings AB (1949b) *Am J Physiol* **158** 251
- Perham RH (1991) *Biochemistry* **30** 850-812
- Pettit FH, Pelley LW and Reed LJ (1975) *Biochem Biophys Res Commun* **65** 575-582
- Pettit FH, Roche TE and Reed LJ (1972) *Biochem Biophys Res Commun* **49** 563
- Piatti PM, Monti LD, Paccioni M, Pontiroli AE and Pozza G (1991) *Metabolism* **40** 926-933

-
- Popov KM, Keishvili NY, Zhao Y, Gui R and Harris RA (1993) *J Biol Chem* **269** 29720-29724
- Popov KM, Li L, Radke GA, OnoK and Roche TE (1994) *Arch Biochem* **296** 497-504
- Portenhauser R and Wieland OH (1972) *Eur J Biochem* **31** 308-314
- Powers-Greenwood SL, Rahmatullah M and Radke GA (1989) *J Biol Chem* **264** 3655-3657
- Pradines-Figueres A, Vannier ZC and Ailhaud G (1988) *Biochem Biophys Res Commun* **154** 643-647
- Pratt ML and Roche TE (1979) *J Biol Chem* **254** 7191-7195
- Pratt ML, Maher JF and Roche TE (1982) *Eur J Biochem* **125** 349-355
- Pratt ML, Roche TE, Dyer DW and Cate RL (1979) *Biochem Biophys Res Commun* **91** 289-296
- Priestman DA, Mistry SC, Halsall A and Randle PJ (1994) *Biochem J* **300** 659-664
- Priestman DA, Mistry SC, Kerbey AL and Randle PJ (1992) *FEBS Letts* **308** 83-86
- Radcliffe PM, Kerbey AL and Randle PJ (1980) *FEBS Letts* **111** 47-50
- Radke GA, OnonK, Ravindran S and Roche TE (1993) *Biochem Biophys Res Commun* **190** 982-991
- Rahmatullah M and Roche TE (1985) *J Biol Chem* **206** 10146-10152
- Rahmatullah M and Roche TE (1988) *J Biol Chem* **263** 8106-8110
- Rahmatullah M, Gopalakrishnan S and Andrew PC (1989b) *J Biol Chem* **264** 2221-2227
- Rahmatullah M, Gopalakrishnan S, Radke GA and Roche TE (1989a) *J Biol Chem* **264** 1245-1251
- Rahmatullah M, Radke GA, Andrew PC (1990) *J Biol Chem* **265** 14512-14517
- Rahmatullah M, Roche TE, Jilka JM, Radke GA and Roche TE (1986) *J Biol Chem* **261** 6515-6523
- Randle PJ (1969) *Nature* **221** 77
- Randle PJ (1983) *Phil Trans R Soc Lond* **302** 47-57
- Randle PJ (1986) *Biochem Soc Trans* **14** 799-806
- Randle PJ (1994) *Diabetologia* **37** S155-S161
- Randle PJ and Pogson CI (1965) *Proc Biochem Soc* 5P

-
- Randle PJ, Denton RM, Pask HT and Severson DL (1974) *Biochem Soc Symp* **39** 75-78
- Randle PJ, England PJ and Denton RM (1970) *Biochem J* **117** 677-695
- Randle PJ, Fuller SJ, Kerbey AL, Sale GJ and Vary TC (1984) *Horm Cell Reg* **8** 139-150
- Randle PJ, Garland PB, Hales CN and Newsholme EA (1963) *Lancet* **1** 785-789
- Randle PJ, Garland PB, Hales CN, Newsholme EA, Denton RM and Pogson CI (1966) *Recent Prog Horm Res* **22** 1-48
- Randle PJ, Kerbey AL and Espinal J (1988) *Diabetes/Metabolism Rev* **4** 623-638
- Randle PJ, Newsholme EA and Garland PB (1964) *Biochem J* **93** 652-665
- Randle PJ, Newsholme EA and Garland PB (1974) *Biochem J* **93** 652-655
- Randle PJ, Sugden PH, Kerbey AL, Radcliffe PM and Hutson NJ (1978) *Biochem Soc Symp* **43** 47-67
- Ravindran S, Radke GA, Guest JR and Roche TE (1996) *J Biol Chem* **271** 653-662
- Raynolds MV, Awald PD, Gordon DF, Guitierrez-Hartmann A, Rule DC, Wood (1990)
- Reed LJ (1960) In *The Enzymes* (Boyer PG, Lardy HA and Myrback eds) Academic Press NY
- Reed LJ (1974) *Acc Chem Res* **7** 40-46
- Reed LJ (1981) *Curr Top Cell Regul* **18** 95-106
- Reed LJ and Damuni Z (1987) *Adv Protein Phosphatases* **4** 59-76
- Reed LJ and Damuni Z (1989)
- Reed LJ and Hackert ML (1990) *J Biol Chem* **265** 8971-8974
- Reed LJ and Oliver RM (1968) *Brookhaven Symp Biol* **21** 397-412
- Reed LJ, Pettit FH, Roche TE, Butterworth PJ, Barrera CR and Tsai CS (1974) *Metabolic Interconversion of Enzymes* (Fischer EH, Krebs EG, Neurath H and Stadmann ER eds) pp 99-106 Springer-Verlag, Berlin, Heidelberg and New York
- Reed LJ, Pettit FH, Yeaman SJ, Teague WM and Bleile DM (1980) *FEBS Symp* **60** 47-50
- Reed LJ and Yeaman SJ (1987) *The Enzymes* third ed. Vol XVIII Control of Phosphorylation, Part B (PD Boyer and EG Krebs eds) pp 77-95 Academic Press, Orlando FL
- Regen DM, Davis WW and Morgan HE (1961) *Federation Proc* **20** 83
- Rider MH and Saggerson ED (1983) *Biochem J* **214** 235-246

- Robinson and Newsholme EA (1967) *BJ* **104** 2C-4C
- Roche TE and Reed LJ (1972) *Biochem Biophys Res Commun* **48** 840-846
- Roche TE, Powers-Greenwood SG and Shi W (1993) *Biochemistry* **32** 5920-5637
- Rodriguez MA, Dias C and Lau TE (1992) *Lipids* **27** 577-581
- Rose JK and Doms RW (1988) *Annu Rev Cell Biol* **4** 257-288
- Rösen P and Reinauer H (1984) *Metabolism* **33** 177-185
- Rutter GA, Diggle TA and Denton RM (1992) *Biochem J* **285** 435-439
- Sabina RL, Patterson P and Holmes EW (1985) *J Biol Chem* **260** 6107-6114
- Saddik M and Lopaschuk GD (1994) *Can J Physiol Pharmacol* **72** 1110-1119
- Saggerson ED (1985) in *New Perspectives in Adipose Tissue* (A Cryer and R Van eds)
Butterworth London pp 87-120
- Saggerson ED (1988) in *Phosphatidate phosphohydrolase Volume I* (D Brindley ed) CRC Press
pp 79-124
- Saggerson ED and Greenbaum AL (1970) *Biochem J* **119** 193-219
- Saha AK, Kurowski TG, Colca JR and Ruderman NB (1994) *Am J Physiol* **267** E95-E101
- Sakai J, Yamamoto T, Nippon-Rnsho (1994) **52** 3184-90
- Sale GJ and Randle PJ (1980) *Biochem J* **188** 409-421
- Sale GJ and Randle PJ (1981) *Eur J Biochem* **120** 535-540
- Sale GJ and Randle PJ (1982a) *Biochem J* **203** 99-108
- Sale GJ and Randle PJ (1982b) *Biochem J* **206** 221-229
- Saltiel AR (1994) *FASEB J* **8** 1034-1040
- Sanadi DR (1963) In *The Enzymes* (Boyer PG, Lardy HA and Myrback eds) Academic Press
NY pp304 344
- Sarda S and Desnuelle P (1958) *Biochim Biophys Acta* **30** 513
- Sauro VS and Strickland KP (1987) *BJ* **244** 743-748
- Scheuer J and Brachfeld N (1966) *Metabolism* **15** 945-954
- Schindler C and Felber JP (1986) *Horm Metab Res* **18** 91-93
- Schneider WJ, Carroll R, Severson DL and Nimpf J (1990) *J Lipid Res* **31** 507-513

-
- Schoonderwoerd K, Broekhoven-Schokker S, Hülsmann WC and Stam H (1990) *Biochem J* **268** 487-492
- Schwartz DD, Williams JL and Malik KU (1993) *Am J Physiol* **265** E439-E445
- Semb H and Olivecrona T (1986) *Biochim Biophys Acta* **876** 249-255
- Semb H and Olivecrona T (1989) *Biochem J* **262** 505-511
- Semenkovich CF, Chen SH, Wims M, Luo C, Li WH and Chan L (1989) *J Lipid Res* **30** 423-431
- Severin SE and Feigina MM (1977) *Adv Enz Regul* **15** 1-21
- Severson DL, Denton RM, Pask HT and Randle PJ (1974) *Biochem J* **23** 225-237
- Shillabeer G, Chamoun C, Hatch G and Lau DC (1995) *Biochem Biophys Res Commun* **207** 768-774
- Shipp JC, Menahan LA and Crass ME (1972) in *Recent Advances in Studies on Cardiac Structure and Metabolism*, Volume 3 (Dhalla ed) pp 179-204 Baltimore University Press
- Siess EA and Wieland OH (1972) *Eur J Biochem* **26** 96-105
- Small CA, Garton AJ and Yeaman SJ (1989) *Biochem J* **258** 67-72
- Speake BK Parkison C and Robinson DS (1985) *Horm Metab Res* **17** 637-640
- Spector AA (1971) *Progr Biochem Pharmacol* **6** 130-176
- Spector AA (1975) *J Lipid Res* **16** 165-179
- Spooner PM, Chernick SS, Garrison MM and Scow RO (1979) *J Biol Chem* **254** 10021-
- Stace PB, Fatania HR, Jackson A, Kerbey AL and Randle PJ (1992) *Biochim Biophys Acta* **1135** 201-206
- Stace PB, Marchington DR, Kerbey AL and Randle PJ (1990) *FEBS Lett* **273** 91-94
- Standl E, Lotz N, Dixel T, Janka H-U and Kolb HJ (1980) *Diabetologia* **18** 463-469
- Stanley CJ and Perham RN (1980) *Biochem J* **191** 147-154
- Stansbie D, Denton RM, Bridges BJ, Pask HT and Randle PJ (1976) *Biochem J* **154** 225-236
- Stearns SB, Tepperman HM and Tepperman J (1979) *J Lipid Res* **20** 654-662
- Stepp LR, Pettit FH, Yeaman SJ and Reed LJ (1983) *J Biol Chem* **258** 9454-9458
- Storlien LH, Jenkins AB, Chisholm DJ, Pascoe WS, Khouri S and Kraegen EW (1991)

Diabetes **40** 280-289

Storlien LH, James DH, Burleigh KM, Chisholm DJ and Kraegen EW (1986) *Am J Physiol*

251 E576-E583

Strålfors P and Belfrage P (1983) *J Biol Chem* **258** 15146-15152

Strålfors P and Honnor RC (1989) *Eur J Biochem* **182** 379-385

Strålfors P, Bjorgell P and Belfrage P (1984) *Proc Natl Acad Sci USA* **81** 3317-3321

Sugden PH and Randle PJ (1978) *Biochem J* **173** 659-668

Sugden PH and Siminster NE (1980) *FEBS Letts* **111** 299-302

Sugden PH, Hutson NJ, Kerbey AL, and Randle PJ (1978) *Biochem J* **169** 433-435

Sugden PH, Kerbey AL, Randle PJ, Walker CA and Reid KBM (1979) *Biochem J* **181** 419-426

Sullivan JE, Brocklehurst KJ, Marley SA, Carey F, Carling D and Beri RK (1994) *FEBS Lett*

353 33-36

Suzuki S, Toyota T, Tamura S, Kikuchi K, Huang L, Villar-Palasi C, Larner J and Goto Y

(1987) *J Biol Chem* **262** 3199-3204

Tabor H, Mehler AH and Stedman GR (1953) *J Biol Chem* **204** 127

Takahashi S, Kawarabayasi y, Nakai T, Sakai J and Yamamoto T (1992) *Proc Natl Acad Sci*

USA **89** 9252-9256

Tan MH, Sara T and Havel RJ (1977) *J Lipid Res* **18** 363-370

Tavangar K, Murata Y, Patel S, Kalinyac JE, Pedersen ME, Goers JF, Hoffman AR and

Kraemer FB (1992) *Am J Physiol* **262** E330-E337

Taylor SL and Jungas RL (1974) *Arch Biochem Biophys* **164** 12 19

Teague WM, Pettit FH, Wu T-L, Silberman SR and Reed LJ (1982) *Biochemistry* **21** 5585

5592

Teague WM, Pettit FH, Yeaman SJ and Ree LJ (1979) *Biochem Biophys Res Commun* **87**

5585-5592

Terto V-VV, Rekhov AN and Smirnov VN (19) *Artherosclerosis* **62** 55-64

Thiebaud D, DeFronzo RA, Jacot E, Golay A, Acheson K, Maeder E, Jequier E and Felber J

(1982) *Metabolism* **31** 1128-1135

- Thomas AP and Denton RM (1986) *Biochem J* **238** 93-101
- Tippet PS and Neet KE (1982) *J Biol Chem* **257** 12839-12845
- Tonks NK, Kearns A and Randle PJ (1982) *Eur J Biochem* **122** 159-551
- Topping DL, Goheer A, Coore HG and Mayes PA (1977) *Biochem Soc Trans* **5** 1000-1001
- Trach V, Buschmans-Denkkel E and Schaper W (1986) *Basic Res Cardiol* **81** 454-464
- Tsai CS, Burgett MW and Reed LJ (1973) *J Biol Chem* **248** 8348-8352
- Ullrich J and Mannschreck A (1967) *Eur J Biochem* **1** 110-116
- Uyeda K, Furuya E and Sherry AD (1981) *J Biol Chem* **256** 8679-8684
- van Bilsen M, van der Vusse GJ, Willemsen PH, Coumans WA, Roeman TH and Reneman RS
(1989) *Circ Res* **64** 304-314
- Van Schaftingen E and Hers HG (1980) *Biochem Biophys Res Commun* **96** 1524-1531
- Vannier C and Ailhaud G (1989) *J Biol Chem* **264** 13206-13216
- Vary TC and Randle PJ (1984) *J Mol Cell Cardiol* **16** 723-733
- Vaughan M (1961) *J Lipid Res* **2** 293
- Vouillmoz E, Maeder E, Jequier E and Felber JP (1984) *Diabetologia* **27** 343A-344A
- Wahlefeld AW (1972) Triglycerides Determination after Enzymatic Hydrolysis In: *Methods of Enzymatic Analysis* pp-1831-1835
- Wahlefeld AW, Möllering H, Gruber W, Bernt E and Röschlau (1972) Boeringer-Mannheim GmbH Dtsch. Patent Meldung P2229849.3
- Wahren J, Felig P and Hagenfeldt L (1978) *Diabetologia* **14** 213-222
- Wakata N, Kawamura Y, Kobayashi M, Araki Y and Kinoshita M (1990) *Comp Biochem Physiol B* **97** 543-545
- Walajtys EI, Gottesman EP and Williamson JR (1974) *J Biol Chem* **249** 1857-1865
- Walker M, Fulcher GR, Catalano C, Petranyi G, Orskov, H and Alberti KGMM (1990) *Clinical Science* **79** 167-174
- Walsh DA, Cooper RH, Denton RM, Bridges BJ and Randle PJ (1976) *Biochem J* **157** 41-67
- Walsh M, Durocher V and Rodriguez A (1989) *Biochem Cell Biol* **67** 48-52
- Wang C-S, Hartsuck J and McConathy WJ (1992) *Biochim Biophys Acta* **1123** 1-17

-
- Weekes J, Hawley SA, Corton J, Shugar D and Hardie DG (1994) *Eur J Biochem* **219** 751-757
- Weiss L, Loffler G and Wieland OH (1974) *Hoppe-Seyler's Z Physiol Chem* **355** 363-377
- Wells PG, Moore GW, Rabin D, Wilkinson GR, Oates JA and Stacpoole PW (1980) *Diabetologia* **19** 109-113
- Whitehouse S and Randle PJ (1973) *Biochem J* **134** 651-653
- Whitehouse S, Cooper RH and Randle PJ (1974) *Biochem J* **142** 1-14
- Wieland OH and Suyter M (1957) *Biochem Z* **329** 320
- Wieland OH, Funke H and Loffler G (1971b) *FEBS Letts* **15** 295-298
- Wieland OH, Siess E, Schulze-Wethmar FH, von Funcke HG and Winton B (1971a) *Arch Biochem Biophys* **143** 593-601
- Wieland OH, von Jagow-Wesymann B and Stukowski B (1969) *Hoppe-Seyler's Z Physiol Chem* **350** 329-334
- Williamson (1964) *J Biol Chem* **239** 2721-2729
- Williamson JR (1974) In *Methods of Enzymatic Analysis* (Bergmeyer HU ed) Vol 3 p1616
- Williamson JR and Krebs HA (1961) *BJ* **80** 540
- Woslait WD, Soler-Argilaga C and Nagy P (1976) *Biochem Biophys Res Commun* **71**
- Wu T-LL and Reed LJ (1984) *Biochemistry* **23** 221-226
- Yamaguchi T, Muroya N, Isobe M and Sugiura M (1972) *Arg Biol Chem* **37** 999-1005
- Yeaman SJ (1990) *Biochim Biophys Acta* **1052** 128-132
- Yeaman SJ, Hutcheson RT, Roche TE, Pettit FH, Brown JR, Reed LJ, Watson DC and Dixon GH (1978) *Biochemistry* **17** 2364-2370
- Yeaman, Smith, Jepson, Wood and Emmison (1994) *Advan Enzyme Regul* **34** 355-370
- Yki-Jarvinen H, Puhakainen I and Koivisto VA (1991) *J Clin Endo Metab* **72** 1268-1277
- Youssef J, Abdel-aleem S and Badr M (1994) *Toxicol Lett* **74** 15-24