

REWRITING THE *GESTA NORMANNORUM DUCUM* IN THE FIFTEENTH CENTURY:

SIMON DE PLUMETOT'S *BREVIS CRONICA COMPENDIOSA DUCUM NORMANNIE*\*

*This article is dedicated to Liesbeth van Houts,  
editor of the Gesta Normannorum ducum,  
generous mentor, colleague and friend.*

#### ABSTRACT

This article offers an analysis, edition, and translation of the *Brevis cronica compendiosa ducum Normannie*, a historiographical account of the dukes of Normandy and their deeds, written at the turn of the fifteenth century by the Norman jurist and man of letters, Simon de Plumetot (1371–1443). Having all but escaped the attention of modern scholars, this study is the first to examine and publish the *Brevis cronica*. It not only demonstrates that the work is of greater importance than its rather scrappy form might at first suggest, but it also looks to place the text within the broader context of Simon's literary and bibliophilic practices, and to determine its *raison d'être*. In doing so, it argues that the *Brevis cronica* was perhaps created as part of a much larger historiographical project, namely an extended chronicle of Normandy, written in the vernacular, the text of which is now lost. By exploring these important issues, the article sheds new light on a wide range of topics, from early humanist book collecting to the writing of history in France in the later Middle Ages.

## INTRODUCTION

As Pierre Courroux recently observed, medieval chroniclers made use of their sources in much the same way as the Church Fathers made use of pagan traditions — that is, “by adapting them to their aims.”<sup>1</sup> This article analyses, edits and translates for the first time the result of one such adaptation, the *Brevis cronica compendiosa ducum Normannie*. Written at the turn of the fifteenth century by Simon de Plumetot (1371–1443), the Norman scholar and early humanist most famous for his collection of autographs, the *Brevis cronica* offers a succinct history of medieval Normandy and its dukes, from the duchy’s pagan roots in modern-day Denmark to the invasion of Anglo-Saxon England by William the Conqueror in 1066. The text, to date, has attracted almost no scholarly attention, save for perfunctory mentions in various catalogues and descriptions of the manuscripts in which it is conserved. At first glance, such neglect would seem to be entirely in keeping with a work that, as the edition below makes clear, is as short as it is scrappy. Surviving thanks only to two early-modern copies, the quality of which at times leaves a great deal to be desired, the *Brevis cronica* is written in a style that is perhaps best described as “draft-like” and sometimes cumbersome to read. It would also appear, *prima facie*, to be little more than a highly-truncated copy of two of the most celebrated — and also widely-diffused — histories of the Norman dukes and the duchy over which they ruled, namely Dudo of Saint-Quentin’s *Historia Normannorum* and the *Gesta Normannorum ducum* by William of Jumièges.

Closer examination suggests a potentially far more interesting story, however, one that reveals the *Brevis cronica* to be a considerably more involved and important text than its rather unassuming form would suggest. Not only can we show that by “authoring” the *Brevis cronica*, Simon interacted with his sources in ways that went beyond that of a mere copyist,

but also that he may have done so as part of a much larger historiographical project, namely an extended history of his native Normandy, written in the vernacular, the text of which is now lost. As a result, the *Brevis cronica* stands witness not only to this lost (vernacular) chronicle, but also to the working methods that underpinned its very creation. This, in turn, sheds new light on the career and historiographical activities of Simon de Plumetot, an important figure who has not always received the scholarly attention he deserves,<sup>2</sup> as well as on a range of more general issues, from the use and transmission of key (Anglo-)Norman texts such as the *Gesta Normannorum ducum* to early humanist book collecting and the writing of history in later medieval France. Moreover, by editing and publishing the text of the *Brevis cronica* in full, what follows makes the work readily available to scholars with an interest in the historiography of the Anglo-Norman world, as well as of medieval France more generally, while the accompanying translation makes the text accessible to students for the first time.

#### THE MANUSCRIPTS

In a reversal of editorial norms, it seems prudent to begin by examining the manuscript history of the *Brevis cronica*, without which its story cannot easily be explained. Today, the text survives in only two manuscripts, both written on paper, the first (and earlier) of which is Paris, Bibliothèque de l'Arsenal, MS 1094, produced in the later fifteenth century (Figs. 1 and 2);<sup>3</sup> the second is Paris, Bibliothèque nationale de France, MS Lat. 12882, made in the sixteenth century (Figs. 3 and 4).<sup>4</sup> In addition, there was once a third copy (now lost) of the text predating both of the above in Paris, Bibliothèque nationale de France, MS Lat. 14663, a paper codex produced during the first quarter of the fifteenth century which, as will be seen

below, provided the shared exemplar for the two extant copies of the *Brevis cronica*.<sup>5</sup> For ease of reference, the following manuscript *sigla* will be used throughout this study:

**A†** = Paris, Bibliothèque nationale de France, MS Lat. 14663, fols. 42r–47v

**B** = Paris, Bibliothèque de l’Arsenal, MS 1094, fols. 150r–153v

**C** = Paris, Bibliothèque nationale de France, MS Lat. 12882, fols. 168r–176r

These three manuscripts have attracted varying levels of scholarly attention, most of which has focused on **A†**.<sup>6</sup> Likely the work of a single scribe and annotator working over the course of two and a half decades (see below), **A†** is a composite codex that combines a range of historiographical, annalistic, genealogical, and heraldic texts, from the early medieval histories of Einhard, Nithard, and Flodoard of Reims to the works of later medieval writers such as Guillaume de Nangis, Landulphus de Columna, and Raoul de Presles, to name but a few examples. Most of the texts contained in **A†** relate, in one way or another, to the history of medieval France and its various predecessor states (both historical and mythical), for example, by recounting the lives and deeds of celebrated rulers from Caesar, Clovis, and Charlemagne to Philip II Augustus, Louis IX, and Charles VI.<sup>7</sup> The book can thus be described as something of an “historical compendium” whose main sources were written, with a small number of exceptions, between the mid-ninth and late fourteenth centuries. Such historical compendia were no rarity at that time, both within Simon’s own library (as will be seen below) and within France more generally, where “[i]n the second half of the fifteenth century, the past was the focus of unprecedented enthusiasm”.<sup>8</sup>

Eight of the forty-six texts compiled in **A†** relate to, and for the most part originate in, the Norman and Angevin periods. In order of their occurrence in the manuscript,<sup>9</sup> these are: a

history of the origins of the counts of Anjou extracted from the twelfth-century compilations of Ralph of Diceto (“De origine comitum Andegavensium”) (fols. 1r–10r);<sup>10</sup> a list (or catalogue) of Rouen’s archbishops from Nicasius (c.250) to William de Vienne (1389–1406) (fol. 24r–v); William of Jumièges’ *Gesta Normannorum ducum* (hereafter *GND*) according to Robert of Torigni’s twelfth-century “F redaction” (fols. 68r–132r);<sup>11</sup> excerpts from Robert of Torigni’s *Chronica* (fols. 130v–157v) and its thirteenth-century continuation (fols. 158r–168v), plus an anonymous compilation on Anglo-Norman history (“De cronicis Francie et Anglie ab anno Domini 1139 usque 1238”), the latter of which might be based on the monastic *Annals of Jumièges* (fols. 168v–175r);<sup>12</sup> some anonymous additions concerning the history of the Anglo-Norman period (fol. 175r).

Codicologically, A† is made up of ten structurally distinct units (or “booklets”) produced between c.1400–1429.<sup>13</sup> Of the eight texts listed above, all but two occur in just two of these booklets. Matthias Tischler has dated one of them (fols. 52r–132v; “Part D”) to c.1402–1409 × 1414–16, probably written in Paris, and the other (fols. 133r–180v; “Part E”) to c.1400–1402, likely written in Rouen.<sup>14</sup> The two texts that occur outside of these booklets are the dynastic chronicle of Anjou, which constitutes a codicological unit *sui generis* and might not have been part of the original volume,<sup>15</sup> and the episcopal catalogue of Rouen, which finds its locus amongst a range of similar “reference lists” included on fols. 21v–24r.<sup>16</sup> Likewise, the *Brevis cronica* that once occupied fols. 42r–47v, according to the book’s fifteenth-century list of contents (“Brevis cronica et compendiosa ducum Normannie”; Fig. 5), belonged to neither of these two booklets, but to a separate one that was produced c.1400 in either Rouen or Paris (fols. 38r–51v; “Part C”).<sup>17</sup> These six folia containing the *Brevis cronica* were subsequently removed from the manuscript, though precisely when this happened is difficult to determine.<sup>18</sup> The fact that the two texts listed either side of the *Brevis cronica* in the contents

list (“Genealogia aliquorum regum Francie per quam apparet quantum attinere potest regi Francie rex Navarre”; “Unde processit regnum de Yvetot et quedam alia”) have both survived intact suggests that this removal was undertaken deliberately and not without some respect for the book’s material integrity. In its former location, the *Brevis cronica* would thus have been bookended, at one end, by Richard Lescot’s genealogy of the Frankish/French kings (fols. 39r–41v) and, at the other, by an anonymous account of the mythical kingdom of Yvetot (fol. 48r), both of which are still extant in the manuscript today.

From a textual perspective, the copies of the *Brevis cronica* found in **B** and **C** appear to be complete. There are no obvious lacunae, and the narrative does not terminate unexpectedly. Scholars have long suspected that both **B** and **C** were copied directly from **A†**, and this is supported by the codicological evidence. Given that reliable accounts of the codicology of these two manuscripts and their relationship with **A†** exist in published form,<sup>19</sup> there is no need for us to go into great detail here. Rather, we will build on these existing discussions and expand them by focussing on the specific evidence of the folia that contain the *Brevis cronica*, which hitherto have escaped detailed commentary. To begin with, Tischler has shown that **A†**, fols. 41r–50v were written by a single scribe — identified by him as “Scribe B”, the main, and possibly only, scribe involved in the book’s production —,<sup>20</sup> likely during a single writing campaign. Further insights can be generated by undertaking a conservative calculation of the average number of letters per line (and page) in the texts that originally bookended the *Brevis cronica* in **A†** (fols. 39r–41v and 48r) and projecting them onto the chronicle’s two extant copies in **B** and **C**. Written in the same hand and as part of the same writing campaign as fols. 39r–41v and 48r, and thus presumably sharing these folia’s *mise-en-page*, the six interim folia now missing from **A†** (fols. 42r–47v) together would have accommodated some 10,500–11,500 letters in total. An identical amount of text is occupied

in both **B** and **C** by a combination of the *Brevis cronica* (**B**, fols. 150r–153v; **C**, fols. 168r–176r) and two shorter texts that relate to it, namely some excerpts from Dudo of Saint-Quentin’s *Historia Normannorum* (hereafter *HN*; one of two main sources of the *Brevis cronica*; see below) and two genealogies of Normandy’s ruling dynasties from the Viking chieftain Rollo (911–27) to King John II of France (1350–64), one composed in Latin, the other in French.<sup>21</sup>

Both these texts were copied straight after, and attached directly onto, the final paragraph of the *Brevis cronica* (**B**, fols. 153v–154v; **C**, fols. 176r–178r). There is no rubric, *incipit/excipit* or other marker to help distinguish them from the *Brevis cronica* proper, and it would thus seem that they were intended to form a single textual unit. If this was the case, it would confirm what the calculation of letter forms has already suggested: that the same three texts were found on the six folia removed from **A**† at an unknown point in time. As our edition below makes clear, the scribal variants that exist between **B** and **C** are both too numerous and too substantial for the former to have served as the exemplar for the latter, and instead it would seem that both manuscripts derive from a shared exemplar. That this exemplar was indeed none other than **A**† is corroborated further by the fact that **B** and **C** preserve not just the *Brevis cronica* along with the excerpts from Dudo and the two genealogies, but also many of the other works contained in the same manuscript as part of a larger textual arrangement (or “dossier”) which, to our knowledge, has no parallel elsewhere.

Of the forty-six texts contained in **A**†, no fewer than thirty reappear in **B**.<sup>22</sup> With both manuscripts essentially preserving their original order of contents,<sup>23</sup> it would seem that the copyist of **B** deliberately rearranged some of the texts by giving priority (and pride of place)

to Einhard's *Vita Karoli* and the Anglo-Norman histories of William of Jumièges and Robert of Torigni with their thirteenth-century continuation(s) (fols. 52r–180v, “Part D” and “E”):

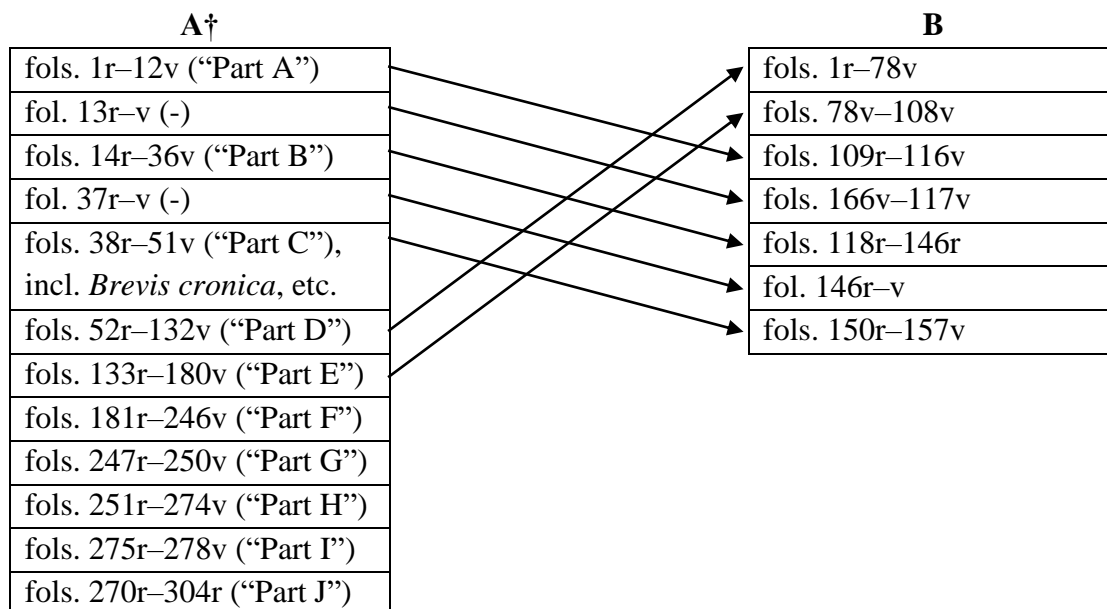

**C** condenses this selection even further by dropping the *Vita Karoli* altogether and instead refocussing its opening sections more or less exclusively on Anglo-Norman history.<sup>24</sup> As a result, the *Brevis cronica* in **C** follows on neatly (and almost seamlessly) from William of Jumièges' *GND* and Robert of Torigni's *Chronica*, copied on the basis of **A†**, fols. 68r–175r,<sup>25</sup> in effect emphasising its close relationship with both these texts.

What **B** and **C** have in common, therefore, is not only that they share an exemplar in **A†**, but also that their respective copyists made a concerted effort to reorganise and rearrange the contents of this exemplar so as to foreground particular groups of texts (or “textual milieus”), one of which, and perhaps the most coherent, concerned the history of Normandy and England during the eleventh to thirteenth centuries. In doing so, these copyists, consciously or otherwise, adopted an agenda that had been established, with a not dissimilar outlook, by the author of the *Brevis cronica* several generations earlier.

## THE AUTHOR/SCRIBE AND HIS SOURCES

Most of the texts contained in **A**† — and copied subsequently in **B** and **C** — are non-authorial works, that is, texts that the scribe copied from elsewhere, rather than composed himself. There are a few exceptions, however, most obviously perhaps the catalogues of secular and spiritual (and biblical) rulers provided in the manuscript's opening booklet,<sup>26</sup> but also the genealogies attached to the end of the *Brevis cronica* (fol. 154r–v). Of course, these can probably be classified as auxiliary or “reference” works, rather than fully-fledged literary or historiographical compositions in their own right, and it seems likely that they were drawn up to assist with, and possibly act as finding aids for, the various narrative texts compiled elsewhere in the same volume. Their location towards the beginning of the book certainly would have facilitated this kind of auxiliary usage.<sup>27</sup> And yet, the production of such reference works suggests a somewhat more sophisticated scribal profile than one would expect from a mere copyist — an observation which is cemented further by the one text that can be considered “authorial” in the stricter sense: the *Brevis cronica*.<sup>28</sup>

Unlike **B** and **C**, both of whose scribes remain anonymous,<sup>29</sup> in the case of **A**† there is relatively concrete information not only about the manuscript's provenance and history of transmission, but also about its maker and original owner/user. Indeed, as an erased colophon re-discovered under UV light by Gilbert Ouy on what was once the manuscript's first folio (now fol. 13r) makes clear, and which subsequent scribal analysis performed by Matthias Tischler has confirmed,<sup>30</sup> we know that **A**† was made, in all its constituent parts, by a single individual, Simon de Plumetot. A man of letters, a lawyer, and later an advisor of the French

and English monarchs, Simon was born in Plumetot in Normandy (dép. Calvados, cant. Douvres-la-Délivrande) on 4 February 1371. He briefly studied at the monastic school of Saint-Victor in Paris before renouncing the life of the regular clergy to study for a baccalaureate in Law at the University of Orléans, c. 1391–99.<sup>31</sup> Simon received ecclesiastical prebends at Senlis (1410), Chartres (1413), Caen, and Bayeux before becoming the advocate of King Charles VI at the parliament in Paris in 1413 — a role which he continued under the English rule of King Henry VI. Simon acted as counsellor at the Palace from 1423 and “conseiller à la Grande Chambre” from 1428. He died 9 July 1443.

As is indicated by this brief summary of Simon’s personal and professional *vita*, he spent the majority of his adult life between Paris and Rouen.<sup>32</sup> While his student years at Saint-Victor and Orléans had primarily been devoted, respectively, to theological and legal matters, the period from 1399/1400 onwards saw Simon turn his attention increasingly to historical and antiquarian studies. Besides the history of France more generally, Simon’s particular area of interest concerned the history of his native Normandy and its rulers, and it is in this context that his autograph volume A† finds its locus. Sitting comfortably amongst Simon’s first-hand copies of the eleventh- and twelfth-century works of William of Jumièges, Robert of Torigni, and Ralph of Diceto, the *Brevis cronica* forms the *pièce de résistance* and authorial calling card of the historical compendium. Again, there are certain caveats. First, if the abovementioned colophon shows that Simon was responsible for creating A†, there is no actual disclosure of authorship anywhere in the text of the *Brevis cronica* itself. This, however, is hardly surprising, given the work’s draft-like form, which, as will be seen below, corresponds well with what we know of Simon’s working practices. On this point, it should also be stressed that labelling the text as “authorial” does not imply out-and-out originality. As far as its contents are concerned, the *Brevis cronica* is, if anything, profoundly derivative,

being closely based on two pre-existing works: William of Jumièges' *GND* and Dudo of Saint-Quentin's *HN*.

Stylistically, however, the *Brevis cronica* is much more than just an amalgamation of the *GND* and *HN* that reproduces their contents verbatim. The use of word-for-word adaptation is surprisingly sporadic throughout, being limited mostly to short phrases, half-sentences, and sometimes individual words. The edition provided at the end of this study gives the text's verbatim citations (in **bold** for the *HN*, and in **bold and italics** for the *GND*) in their entirety, which is why two examples will suffice here:

Qui Robertus Rothomagensis respondit, quod **nimis** volebat **equitare** quam **ultraque legem agere**, et nichilominus prefatus dux Francorum contra regem rebellans fecit se in regem ungi, III.<sup>o</sup> kalendas julii. (**B**, fol. 150r; cf. *HN*, 173)

Ricardus etiam ejus filius qui *Normannicam pene patriam unam Christi insignivit ecclesiam*. Rusticos Normannie rebellare volentes, per Radulphum comitem castigari fecit, et *truncatis manibus* et *pedibus, inutiles*, dimisit ceteris exemplum prebens, qui *ad sua aratra sunt reversi*. *Eadem tempestate* Guillelmus ejusdem Ricardi frater ex patre, qui Guillelmus comitatum Oximensem habuerat immunis, rebellavit contra fratrem, qui captus Rothomagi per quinquennium in carcere detrusus. (**B**, fols. 151v–152r; cf. *GND*, 2: 6)

As these examples show, Simon was fairly selective in how he used the sources available to him. On the whole, he preferred to rephrase and refocus their narrative accounts, rather than copying them wholesale. Likewise, he exercised great selectivity in how he combined the

different, and sometimes divergent, versions of events not only between the *GND* and *HN*, but also, and importantly, between the *GND*'s various eleventh- and twelfth-century redactions, of which Simon appears to have used at least two.<sup>33</sup>

For the early parts of its narrative, up to the death of Duke Richard I of Normandy (942–96) (**B**, bottom of fol. 151v), the *Brevis cronica* draws more or less exclusively on Dudo's *HN*. This is true even in most cases where one of the *GND*'s redactions offers an alternative or reproduces parts of the *HN* verbatim — as was the case with “redaction A”, whose anonymous eleventh-century redactor reproduced the four books of Dudo's work in full, and Robert of Torigni's “redaction F”, written c.1139–59, which re-inserted substantial passages of the *HN* back into the *GND* after they had been excised purposefully by both William of Jumièges (“redaction C”, c.1050–70) and Orderic Vitalis (“redaction E”, c.1109–1113).<sup>34</sup> There are two notable exceptions, however. In both cases, Simon can be seen to substitute, or at least supplement, the information provided by Dudo with a corresponding passage found in the *GND*. The first of these passages concerns the final years of Rollo's life (**B**, fol. 150v), where the *Brevis cronica* relies on Robert of Torigni's twelfth-century redaction of the *GND*, rather than on the *HN* directly, for its account of the Battle of Soissons in 923 and the subsequent acclamation of Rollo's son and successor, William Longsword.<sup>35</sup>

The second passage that forms an exception to Simon's preferential treatment of the *HN* over the *GND* occurs shortly afterwards (bottom of **B**, fol. 150v). Here, the various events that shaped the aftermath of Rollo's death are grouped together succinctly in a single sentence closely mirroring the corresponding summary account provided in the *GND*, rather than the drawn-out narrative of the *HN* that stretches over several pages and follows a different sequence of events.<sup>36</sup> Apart from these exceptions, however, the *Brevis cronica* follows a

straightforward pattern of composition in that it relies on the *HN* for as long as possible, and only once Dudo's narrative comes to an end does it switch to the *GND* (**B**, fols. 151v–153v). Which and how many of the *GND*'s redactions Simon used is difficult to determine, not least due to the limited amount of verbatim quotations. For the same reasons, it has proved impossible at this point to identify with absolute certainty his exemplar(s) amongst the surviving manuscripts of the *GND* and *HN*.<sup>37</sup> Given that Simon spent the best part of his career between Paris and Rouen, he presumably would have had access to the libraries of several institutions located in and around the two capital cities. One of these was Saint-Victor, where Simon had studied (briefly) as a young adult and to which he returned frequently during later decades. When leaving Paris for Rouen in the 1430s, where he had been appointed at the Exchequer by Henry VI, Simon gave most of his own treasured book collection to Saint-Victor, and **A†** was amongst it.<sup>38</sup> Another was the library at the abbey of Jumièges, some 20 km (as the crow flies) west of the Norman capital, the importance of which is discussed in more detail below.

For now, we can do little more than conclude that Simon likely used one of the following combinations of sources for his compilation of the *Brevis cronica*: (1) *HN* + *GND* “redaction F” + *GND* “redaction A”; (2) *HN* + *GND* “redaction F” + *GND* “redaction C”; and (3) *GND* “redaction F” + *GND* “redaction A”. Of these three combinations, the first two emerge as the most probable given the evidence discussed earlier in this article, though none of them can be verified or excluded with absolute certainty. Either way, Simon must have had access to at least two (if not more) manuscripts. These he combined creatively, and with much authorial *esprit*, when rewriting the history of his native Normandy in the fifteenth century.

THE *BREVIS CRONICA* IN CONTEXT

While we are thus able to date, attribute and analyse the *Brevis cronica* in terms of its codicology and manuscript sources with relative confidence, establishing it in a wider historical and literary context poses more of a challenge. Indeed, while our analysis of the text reveals that Simon de Plumetot approached the task of composing the *Brevis cronica* with a certain amount of “creative flair”, falling somewhere between *scriptor* and *compiler* in St Bonaventure’s (1221–74) neat and oft-quoted definition of authorship,<sup>39</sup> his authorial motives, which are never stated, can only be hypothesised. What is more, the *Brevis cronica*’s atypical form — it is not a straightforward copy, nor a continuation, nor a truly original work — means it is difficult to draw any firm conclusions as to its place both within the transmission of the *GND* and, more broadly, within French and Latin historical writing of the later Middle Ages.

We shall return to these issues below. For the moment, let us continue by setting the *Brevis cronica* within those wider contexts about which we can be more certain. In the first instance, we have already noted that the booklet in A† that once contained the *Brevis cronica* was produced c.1400 in either Rouen or Paris. It thus dates from the earlier part of Simon’s career, when he was a man in his late 20s or early 30s, who in the previous year had completed his legal studies at the University of Orléans. The *Brevis cronica* is, therefore, one of the earliest texts produced by Simon to survive in what remains of his private library, meticulously reconstructed by Gilbert Ouy over forty years ago,<sup>40</sup> and it certainly bears witness to Simon’s first interaction with the *HN* and *GND*, the latter of which he would copy some years later (c.1402–1409 × 1414–16).<sup>41</sup> In terms of Simon’s wider library, the manuscript in which the *Brevis cronica* was once found is one of several codices (some surviving, others not) to

contain historiographical material. Of these, two are of particular interest, namely a lost manuscript once bearing the pressmark MS BBB.12 and Vatican Library, MS Ottoboni Lat. 3081, both of which we will look at in more detail below. For now, let us remark simply that A† is at once reflective of Simon de Plumetot's personal interests, which, in terms of historiography, focused on royal privilege and Anglo-French relations,<sup>42</sup> as well as of his private library more generally, which was formed, as far as we can tell, primarily of texts copied either by him or by others at his behest.<sup>43</sup> That said, if Simon's surviving library is notable for the number of copied texts it contains, as well as for its impressive range of autograph works,<sup>44</sup> one thing that distinguishes it is the lack of texts authored by Simon himself.<sup>45</sup> In this context, and in light of the observations made earlier in this article, the *Brevis cronica* can be said to represent something of an important exception.

Accepting this premise, however, brings us no closer to determining why Simon decided to create the text in the first place. In order for us to try and answer this key question, it is helpful to begin by establishing what the *Brevis cronica* is *not*. In the narrower sense, much of this has already been discussed above. Viewed more broadly, however, it is useful to compare the *Brevis cronica* with similar historiographical works, especially those with which Simon de Plumetot was familiar.<sup>46</sup> Indeed, the manuscript in which Simon's copy of the *Brevis cronica* was once found itself contains a number of historiographical texts similar in length and subject matter. These include the short history of the origins of the counts of Anjou extracted from the twelfth-century compilations of Ralph of Diceto, already noted above, and various abridged chronicles of the kings of France, including that written by Guillaume de Nangis.<sup>47</sup> Given Simon's noted interest in the history of his native land,<sup>48</sup> it would not be unreasonable to suggest that, in creating the *Brevis cronica*, not only did he conceive of it as replicating for the Norman dukes that which he had seen elsewhere, but,

given the volatility of Anglo-French relations in the early fifteenth century, that he also had some political or ideological motive for doing so.

Sadly, neither of these ideas holds up to closer inspection. In structural terms, both the short Anjou chronicle, which may not have even formed part of **A†** as originally bound, and the abridged chronicle of Guillaume de Nangis are more tightly ordered and polished texts than the *Brevis cronica*. Each presents the deeds of each count or king under individualised, separately headed sections, with the latter being deliberately ordered as such so as to help guide those visiting the royal necropolis at Saint-Denis.<sup>49</sup> By contrast, the *Brevis cronica* lacks any formal sense of structure, besides following a rather basic chronological outline. Stylistically, too, it is noticeably different from (and indeed inferior to) the histories produced by authors of earlier centuries such as William of Jumièges and Guillaume de Nangis,<sup>50</sup> with much of its grammar and syntax being decidedly “draft-like”. What is more, the *Brevis cronica* does not appear to have been produced with any specific political or ideological agenda in mind. It is therefore not a text that looks either to resituate the French kings within the history of Normandy, or to comment on their parentage in the way that other historiographical texts of this period, including those copied by Simon de Plumetot elsewhere in **A†**, sought to do.<sup>51</sup> It is also not a text that appears to pass judgement (or praise) on the dukes of Normandy, or on any other individual, in that the historical episodes selected by Simon do not cast anyone in a particularly negative or positive light (nor does Simon interject with comments of his own).

That said, if the *Brevis cronica* cannot be identified as a political or ideological text in its own right, it nevertheless forms part of a collection recognised as at once Norman and political in character.<sup>52</sup> If the latter of these two observations, in the light of what has just

been noted, has relatively little bearing on the reasons why Simon authored the *Brevis cronica*, the first is central. As previously stated, the *Brevis cronica* is one of a number of historiographical texts contained in A† to relate to Normandy, and in particular to its history during the Anglo-Norman and Angevin periods. Moreover, A† is not the only manuscript to bear witness to Simon’s interest in his native land. His private library shows that he eagerly copied, collected, and/or created texts relating to various aspects of Normandy’s past, and that he did so making full use of his Norman contacts.<sup>53</sup> Both A† and the Vatican manuscript mentioned above contain marginal notes specifying the Norman repositories visited by Simon in his pursuit of texts,<sup>54</sup> while he was aided in this pursuit by three copyists (Guillaume de Longueuil, Adam de Baudribosc, and Hugues Berthelot), all of them Norman in both origin and outlook.<sup>55</sup>

In the context of his “Norman” activities, the *Brevis cronica* as once found in “Part C” of A† was produced at around the same time (i.e., c.1400) as “Part E” of the same manuscript, which contains a number of historiographical texts of Norman origin or focus. For our purposes, the most interesting of these is a compilation on Anglo-Norman history, found in the part of the manuscript described by the fifteenth-century list of contents as “De cronicis Francie et Anglie ab anno Domini 1139 usque 1238”. It is one of two texts of this sort once found in Simon’s library. The other previously formed part of the lost MS BBB.12 introduced above, which in the early sixteenth-century was held in the library of Saint-Victor in Paris.<sup>56</sup> Occupying the manuscript’s first forty folia, the text is listed in a catalogue of the abbey’s library as “Cronica Normannie in gallico, ab Hastingo, eorum duce, usque ad annum Domini 1223”.<sup>57</sup>

This is of interest for a number of reasons. In the first instance, the fifteenth-century description of the text “De cronicis” in A† obscures its complexity and chronological scope. Comprised largely of excerpts from Robert of Torigni’s *Chronica* and its thirteenth-century continuation, its final part (fols. 168v–175r) is formed of annalistic notes from the death of William the Conqueror in 1087 to the birth of Edward I in 1239. Unlike the *Brevis cronica*, Simon appears to have copied this text from the original, namely a reworking of extracts from the *Annals of Jumièges*, although it is not impossible he worked directly from the *Annals* and carried out this reworking himself.<sup>58</sup> What is more important, from our point of view, is the chronological range covered by these notes, for although they cannot be said to pick up precisely where the narrative of the *Brevis cronica* leaves off, ending as it does with William the Conqueror’s return to Normandy following his successful invasion of England, they do begin in a chronologically consistent way with William’s death. As for the lost “Cronica Normannie” in MS BBB.12, this, at least according to the above-mentioned catalogue, began its history of Normandy with the arrival of Hasting, just as the *Brevis cronica* does, and it ended at a point not too far removed from the Jumièges notes in A†, which include an entry on the death of Philip Augustus (1180–1223) and the coronation of his son, Louis VIII (1223–26), in 1223.<sup>59</sup>

It would be misleading, of course, to suggest that the lost “Cronica Normannie” in MS BBB.12 was simply a combination of the *Brevis cronica* and the reworked notes from the *Annals of Jumièges*. Still, placed in this context, it is possible to see the *Brevis cronica* for what it is, namely a personal reference work, which Simon used (or intended to use), along with the Jumièges notes, in relation to some wider project. This, it must be admitted, may have been nothing more than a desire to collect historiographical material relating to his native Normandy, and, as a consequence, to expand his nascent private library. It is not too

far fetched to suggest, however, that Simon sought to collect and compile such texts not just out of intellectual curiosity, but with the aim of creating something new — in this instance, an extended chronicle of his native land, which, if we accept that the lost “Cronica Normannie” is this work, was written in the vernacular. Study of MS Ottoboni Lat. 3081, which is itself a partial copy of MS BBB.12, has shown how Simon collaborated with his copyist, Adam de Baudribosc, in the drafting of an historical compilation,<sup>60</sup> and it would therefore be within reason to suggest that the same dynamic may have also been behind the creation of the lost “Cronica Normannie” and, by extension, the Jumièges notes and the *Brevis cronica*.

Whatever the case may be, the *Brevis cronica* is characteristic of Simon’s historiographical working methods, which involved scouring libraries and compiling texts based on what he found. As noted above, we can only hypothesise as to which and how many existing copies of the *GND* Simon used as exemplars in his writing of the *Brevis cronica*. Analysis of his copy of the *GND* in A† shows it is from a manuscript of Norman provenance of unknown origin now at Leiden.<sup>61</sup> Given Simon’s interaction c.1400–1402 with the *Annals of Jumièges*, written at a house from whose abbot he had requested a grace expectative a few years earlier,<sup>62</sup> it would not be unreasonable to suggest that he was familiar with the copy of the *GND*, now Rouen, Bibliothèque Municipale, MS 1173 (Y. 11),<sup>63</sup> known to have come from this monastery; that the Leiden manuscript perhaps also came from Jumièges; and that Simon de Plumetot used either one or both in compiling the *Brevis cronica*. In support of such ideas, it is also worth noting that the abbot from whom Simon had requested a grace expectative in the 1390s, and to whom he would have addressed any request to access the monastic library, was none other than Simon du Bosc (1391–1418), a fellow Norman intellectual and avid collector of books. The bibliophile abbot of Jumièges and his namesake would both come to

play a role in documenting early-fifteenth-century attempts to resolve the so-called Western Schism, and while it has been argued that they shared no known links besides being Norman,<sup>64</sup> it is thus possible, and perhaps likely, that the *Brevis cronica* stands as witness to previously undetected interactions between the two men.

For the moment, however, such things must remain the subject of conjecture. Nevertheless, one thing to which the *Brevis cronica* can be said with confidence to stand witness is the use and transmission of the *GND* across the centuries. Described fittingly by Elisabeth van Houts as “a living text”, the *GND* was revised and updated by various authors throughout the central Middle Ages for various purposes.<sup>65</sup> While the *Brevis cronica* is in no way a polished and lengthy work in the manner of those produced by some of the *GND*’s previous adapters and continuators, such as Orderic Vitalis and Robert of Torigni, the evidence discussed above shows how it may have been used as the basis for a much larger project: a new vernacular history of Normandy, likely written in French, from the raids of Hasting to the death of Philip Augustus, to whose control the duchy had reverted in 1204. If this was indeed the case, then the period in which this work was undertaken, during which Anglo-French relations steadily deteriorated, resulting in the eventual occupation of Rouen by English forces, could not have been more apposite.

#### NOTE ON THE EDITION AND TRANSLATION

Given today’s absence of the *Brevis cronica* from **A**†, the following edition is based on the text as it survives in **B**, with the variants of **C** noted throughout. (When both **B** and **C** contain an error, the correction has been supplied in the main text, with the original highlighted in

bold in the footnotes.) This selection of **B** as the edition's base text is justified by both its relative location within the text's manuscript tradition (earlier than **C**) and its superiority (when compared to **C**) in terms of the textual quality, integrity and lack of corruption. The folio numbers of **B** are printed in square brackets in the Latin text. Although the original punctuation of the *Brevis cronica* is very much in keeping with its "draft-like" form, it has here been modernised at the explicit request of this journal's editorial board. For the same reason, all abbreviations have been expanded silently. In terms of orthography, "u/v" and "i/j" are kept as distinct vowels and consonants, respectively. To avoid confusion, quotation marks are used to indicate reported speech, although neither scribe uses them. Within the main text, the following symbols are used:

[ ] indicates supply by the editors of letters/words missing from **B** but present in **C**.

< > indicates supply by the editors of letters/words omitted by the scribe.

† † indicates words transcribed as they are found in the manuscripts, but for which no known Latin word has been identified or which make no grammatical sense in the context of the sentence within which they are found.

For ease of reference, the text copied verbatim by Simon de Plumetot from his two main sources has been highlighted in **bold** (*HN*) and in ***bold and italics*** (*GND*). Section numbers have also been introduced for the benefit of the reader. These mostly follow the rubricated paragraph marks found in **B**, but some of them have been inserted in the absence of such marks to avoid unwieldy and overly long paragraphs, and to facilitate study.

The translation does not pretend to offer a strict, literal rendering of the original Latin into modern English to the exacting standards that could be achieved by philologist experts.

Rather, it attempts to provide a readable, modernised and user-friendly translation of the text that can be appreciated by academic colleagues and students wishing to engage with the *Brevis cronica* primarily in terms of its narrative content and literary-historical context. Where possible, the individuals mentioned, and their dates of birth, death or office, are identified in the footnotes. Place names are also identified according to the standard French practice of listing department, canton and, where applicable, commune.

BENJAMIN POHL, University of Bristol ([benjamin.pohl@bristol.ac.uk](mailto:benjamin.pohl@bristol.ac.uk))

RICHARD ALLEN, St Peter's College, Oxford ([richard.allen@spc.ox.ac.uk](mailto:richard.allen@spc.ox.ac.uk))

## EDITION

[Fol. 150r] Brevis cronica compendiosa<sup>1</sup> ducum Normannie.

[§1] Daci glorientur **se ex Anthenore<sup>2</sup> progenitos**. Dux Dacorum Hastinus Franciam cum suis appulit eamque devastat, postea Rome iter arripuit et **Lunx urbem,<sup>3</sup> que Luna dicitur**, in dolo se mortuum fingendo cepit, et gloriabatur se Romam cepisse, cujus<sup>4</sup> rei contrario conperto, eam incendit, et ad Franciam revertitur, et cum rege Francorum mediantibus donis ab ipso Hastino receptis pacificatur. Interea rex Dacie voluit plures de suis a regno expellere, cui expulsionem Rollo et Gurim filii cujusdam potentissimi ducis Dacie, qui quasi totam Daciam sibi adquisierat, se opposuerunt ad requestam juvenum prescriptorum, rex Dacie eos invadit. Cujus victoriam illa<sup>5</sup> vice habuerunt. Sed altera die subdole Gurim in bello occidit et Rollonem fugavit. Qui Rollo Stanzam insulam applicuit<sup>6</sup> cum sex navibus, ipseque in sompnis monitus ad Anglos perrexit.

[§2] Modus autem monitionis fuit iste: “**Rollo, velociter surge, pontum festinanter navigio<sup>7</sup> transmeans, ad Anglos perge. Ibi audies quod ad patriam sospes reverteris, perpetuaque pace in ea sine detrimento frueris**”. Quod sompnum a christicola<sup>8</sup> sapiente interpretatus est hoc modo.

---

<sup>1</sup> compendiosa *scored through* **B**.

<sup>2</sup> Antenore **C**.

<sup>3</sup> **Lunxurbom BC**.

<sup>4</sup> *camis* **B**.

<sup>5</sup> *illam* **C**.

<sup>6</sup> *aplicuit* **B**.

<sup>7</sup> *navigis* **C**.

<sup>8</sup> *cpristicolla [sic]* **C**.

[§3] “**Tu, vergente futuri temporis cursu, sacrosancto baptismate purificaberis, predignus<que> christicola efficieris, et ab errore fluctuantis seculi ad Anglos<sup>9</sup> pervenies, pacemque glorie perhennis cum illis habebis**”. Statimque aliquos Anglos<sup>10</sup> sue dicioni subjugavit, et monitus per sompnum facta prius federacione inter Alstenum regem Anglorum. Wulgranium non sine maris periculo appulit, et terram illam et Frisiam devastavit et sub tributo posuit, et Rainerum<sup>11</sup> Bugicoli cepit et tandem dimisit. Et anno ab incarnatione Domini octingentesimo LXXVI<sup>12</sup> per fluvium Secane apud Gimesium appulit,<sup>13</sup> et in ecclesia Sancti Vedasti corpus beate Hameltrudis supra altare posuit ibique cappellam ejusdem nomine edificavit,<sup>14</sup> et Rotom<ag>ensibus<sup>15</sup> securitatem dedit. Rothomagi venit sine difficultate per portam Sancti Martini elegitque in illis partibus residere.

[§4] Ad Archas ivit, post hec Meulentum cepit, et Parisium obsedit et Baiocas cepit, et eam subvertit, filiamque Berengarii principis sibi connubio ascivit, ex qua Guillelmum<sup>16</sup> suscepit. Rediitque Parisiis et Ebrocas aliquos de suis misit, et cepit et revertitur apud Lontessiam.<sup>17</sup> Angli<sup>18</sup> sciens Rollonem<sup>19</sup> Parisiensem civitatem obsedisse, contra eorum regem Alstemum<sup>20</sup> rebellarunt, qui auxilium Rollonis petiit et obtinuit, deditque Rolloni<sup>21</sup> dimidium regni ad hoc

---

<sup>9</sup> Angelos C.

<sup>10</sup> Angelos C.

<sup>11</sup> Reinerum C.

<sup>12</sup> septuagesimo sexto C.

<sup>13</sup> Gimesius applicuit C.

<sup>14</sup> edificatur C.

<sup>15</sup> Rothom<ag>ensibus C.

<sup>16</sup> cepit *scored through* C.

<sup>17</sup> Lentessiam C.

<sup>18</sup> **Angle BC.**

<sup>19</sup> Rolonen C.

<sup>20</sup> Altenum C.

<sup>21</sup> Roloni C.

ut rebelles subjugaret, quibus sub jugo per dictum Rollonem positus et reconciliatis<sup>22</sup> medietatem regni reorum eidem Rolloni devorant sed Rollo ei reddidit, tantum requirens, ut qui eum sequi maluerint non prohiberet. Rex autem hec annuens voluit secum ire in Franciam, [[quod refutavit reversusque Rollo in Francia]], exercitus suos dividit.

[§5] Karolus rex per medium Franconis archiepiscopi<sup>23</sup> Rothomagensis pacem cum eo querit, et obtinet trium mensium dumtaxat. Quibus finitis consilio Ricardi et Ebali Burgundiones et Franci bellare contra Rollonem ceperunt. Rollo vero<sup>24</sup> Francia<m> laniare et terras usque Clarum Montem devastare,<sup>25</sup> et per Sanctum Benedictum quem<sup>26</sup> non contaminavit. Stampas devastavit, et Parisius remeando rusticos debellavit, et Carnotum [fol. 150v] obsedit et ibi bellum crudele cum Francis et Burgundionibus<sup>27</sup> habuit, tandem episcopo cum cruce et armis bellum intrante, Rollo declinavit ab exercitu<sup>28</sup> ne morte preoccuparetur. Ebulus qui non fuerat in bello exercitum paganorum in Monte Leugas<sup>29</sup> insequitur, sed non profuit. Rollo totam<sup>30</sup> patriam cepit amplius devastare. Franci petunt a Karolo quod pax et concordia fiat cum Rollone dando ei filiam suam<sup>31</sup> Gislam, et terram ab Epte fluvio usque ad mare, quod Francone archiepiscopo Rothomagensi intercedente factum est. Et a Roberto duce suscipitur Rollo de sacro fonte pacto prius interveniente, per quod Britanniam<sup>32</sup> donec terra prius dicta culta foret, concedebat, refutata Flandria tanquam paludosa. Non tamen voluit regis pedem

---

<sup>22</sup> reconsiliatis C.

<sup>23</sup> argen' B.

<sup>24</sup> vera BC.

<sup>25</sup> devastarere C.

<sup>26</sup> quem om. C.

<sup>27</sup> Burgonibus C.

<sup>28</sup> tandem episcopo ... ab exercitu om. C.

<sup>29</sup> exequitur *scored through* C.

<sup>30</sup> tantam C.

<sup>31</sup> suam om. C.

<sup>32</sup> Britaniam C.

osculari sed precepit militi, qui regem fecit resupinum. Sicque baptizatus fuit Rollo anno incarnationis nongentesimo XII<sup>o</sup>,<sup>33</sup> et Robertus in<sup>34</sup> sacro fonte nominatus, et sic per XXXVI annos ab eventu suo usque ad baptismum patriam devastaverat, sed suscepto baptisate ecclesias dotavit, et residuum [[predictis]] suis gentibus divisit, et postea dictam Gislam in uxorem assumpsit. **Jura et decreta leges sempiternas principum sanctitas et decretas, plebi indixit.** Britannicos<sup>35</sup> sibi rebelles subjugavit, furtum prohibuit.

[§6] Legatos Karoli regis eo inscio cum uxore diu colloquium habentes publice jugulari fecit. Quod audiens Robertus dux Francorum pacis federa disrupta intelligens contra regem Karolum stetit, misitque legatos Roberto, qui prius Rollo dicebatur Rothomagensis, dicens se velle regnum Francorum contra Karolum acquirere. Qui Robertus Rothomagensis respondit, quod **nimis** volebat **equitare** quam **ultraque**<sup>36</sup> **legem agere**, et nichilominus prefatus dux Francorum contra regem rebellans fecit se in<sup>37</sup> regem ungi, III.<sup>o</sup> kalendas julii. Sed rex Karolus ante finem anni regnum recuperavit et dictum ducem peremit, sed Herbertus comes ipsum Karolum cepit, et in castro Perone usque ad mortem detinuit. Cui successit Radulfus<sup>38</sup> filius Ricardi ducis Burgundie, dicti Karoli filiulus uxorque dicti Karoli cum Ludovico filio suo<sup>39</sup> ad patrem suum regem Anglie profecit, **animositatem Herberti et Hugonis**<sup>40</sup> **Magni**, filii predicti Roberti ducis Francorum, **nimum metuens**.

---

<sup>33</sup> duodecimo C.

<sup>34</sup> a C.

<sup>35</sup> Britanicos C.

<sup>36</sup> utraque B.

<sup>37</sup> in *om.* C.

<sup>38</sup> Rodulphus C.

<sup>39</sup> suo *om.* C.

<sup>40</sup> Heberti et Hugoni C.

[§7] Rollo vero defuncta<sup>41</sup> uxore sua, Popam, ex qua Willelmum filium susceperat *iterum repetens*<sup>42</sup> *sibi copulavit*, et vocatis Normannis et Britonibus dictum Guillelmum<sup>43</sup> illis exponit, et eum in eorum dominum prefecit,<sup>44</sup> eosdemque sub sacramento fidei filio subegit. *Post hoc uno vivens lustro consumptus senio hominem exiit in Christo.*

[§8] Post Rollonis obitum, Guillelmus ejus et Pope filius, qui Bothoni ditissimo comiti ad educandum commendatus fuerat, et voluerat se fieri monachum, et Gimesias voluerat ingredi cepit amplius crescere. Britones contra eum rebellantes subjugavit, et Berengarium eorum ducem sub sacramento perseverande fidelitatis et servicii sibi connexuit, et Alanum fugavit qui Angliam adiit. Qui Guillelmus<sup>45</sup> uxorem accepit, et Hugoni Magno atque Herberto se reconciliavit.<sup>46</sup>

[§9] Post hec Riulfus<sup>47</sup> perfidus rebellavit contra eum, quem cum suis complicitibus in Prato Belli propre Rothomagum debellavit, et redeundo<sup>48</sup> de bello **[fol. 151r]** nuncium de filii nativitate habuit, sicque exaltatus est quod Franci, Burgundi, Flandrenses,<sup>49</sup> Angli et Dacigene,<sup>50</sup> et Isbernenses<sup>51</sup> ei parebant. Filiam suam Guillelmo<sup>52</sup> Pictavensi nupsit.

---

<sup>41</sup> deffuncta C.

<sup>42</sup> reptens [sic] C.

<sup>43</sup> Willelmum C.

<sup>44</sup> prefixit C.

<sup>45</sup> **Guillelmo BC.**

<sup>46</sup> Heberto se reconsiliavit C.

<sup>47</sup> Riulphus C.

<sup>48</sup> reddeundo C.

<sup>49</sup> Flandrense C.

<sup>50</sup> **Dricigene BC.**

<sup>51</sup> Ibernenses C.

<sup>52</sup> Guillermo C.

Herbertus vero dedit dicto Guillelmo<sup>53</sup> Rothomagensi, consilio Hugonis Magni ducis, filiam suam in uxorem. Rex Anglie Alst<m>us misit eidem Guillelmo<sup>54</sup> legatos, cum muneribus, deprecans<sup>55</sup> ut Ludovicum, nepotem suum, et Alstemum filium dicti Karoli regis Francie revocaret ad Francie regnum, et susciperet Alanum a Britannia<sup>56</sup> offensionis culpa ejectum. Et ilico,<sup>57</sup> consultu dicti **Guillelmi**,<sup>58</sup> **Hugo Magnus dux atque Herbertus satrapa principum, ascitis episcopis consilio metropolitanorum, revocaverunt festinanter dictum Ludovicum**, et eum **unxerunt sibi regem populorum Francia, Burgundiaque morantium. Alanum vero cum Ludovico regressum, Guillelmus**,<sup>59</sup> **pro amore regis Alstemi, recepit.**

[§10] Elapso autem lustris **spacio, ceperunt Franci contra** Ludovicum rebellare, qui a Henrico rege Trasuhenanum<sup>60</sup> petens auxilium non potuit nisi per medium Guillelmi<sup>61</sup> obtinere. Cum quo Guillelmo predictus Ludovicus Rothomagi diu mansit, misitque legatos<sup>62</sup> idem Guillelmus ad dictum regem Henricum pro pace procuranda. Qui rex Henricus remisit legatos<sup>63</sup> et cum eis Cononem ducem pro obside pacem tractando, quem Guillelmus noluit retinere sed secum duxit ad placitum cum Ludovico rege Francorum in pago Laudunensi contra Hugonem et Herbertum, et ibi confederantur Henricus et Ludovicus<sup>64</sup> reges, presentibus non tamen consentientibus Hugone et Herberto. Nichilominus Ludovicus rex

---

<sup>53</sup> dedit vero dicto Guillermo C.

<sup>54</sup> Guillermo C.

<sup>55</sup> deprecant B.

<sup>56</sup> Altanu(m) [*sic*] a Britania C.

<sup>57</sup> illico C.

<sup>58</sup> Guillelmi C.

<sup>59</sup> Guillelmus C.

<sup>60</sup> Trasuehanum C.

<sup>61</sup> Guillelmi C.

<sup>62</sup> legatus C.

<sup>63</sup> regatos [*sic*] C.

<sup>64</sup> Ludvicus C.

reconciliatur et Laudunensi<sup>65</sup> revertitur. Et audito quod filium scilicet<sup>66</sup> ex uxore Gerberga natum haberet, fecit eum per Guillelmum<sup>67</sup> de sacro fonte levari et Lotharium<sup>68</sup> vocari. Quibus peractis Guillelmus ad propria rediens<sup>69</sup> construxit Gemesias<sup>70</sup> templum mirabile et a Martino loci abbate inquisivit: **“Cur christiana religio tripertito ordine ecclesiam frequentat?”** Quo declarato omnino voluit fieri monachus, ibidem, Normannique et Britones sacramento fidei Ricardo ejus filio se submiserunt. Postquam Arnulphus Flandrensis marchio<sup>71</sup> abstulit Heluino castrum, quod dicitur Monasterioli. Qui Heluinus primo Hugonis ducis auxilio petito et denegato a Guillelmo duce auxilium obtinuit, per quod dictum castrum recuperavit.

[§11] Arnulphus vero capta pace trium mensium cum Guillelmo ad placitum convenerunt, in quo prodicione et subdole Guillelmus dux occiditur, per Arnulphum, anno incarnationis **Domini no<n>gesimo XLIII<sup>o</sup>,<sup>72</sup> XVI<sup>o</sup> kalendas januarii, rege Ludovico regnum Francie tenente.**<sup>73</sup> Quo defuncto,<sup>74</sup> Britones et Normanni Ricardum<sup>75</sup> ejus filium pro duce sibi iterum constituerunt. Audito per Ludovicum obitu Guillelmi<sup>76</sup> venit Rothomagum, et secum retinuit Ricardum puerum, quod displicuit civibus et impediverunt et tandem habuit eum ad educandum. Finxitque Ludovicus velle capere Atrabatum et destruere Arnulphum,

---

<sup>65</sup> reconsiliatus et Laudunii C.

<sup>66</sup> scilicet *om.* C.

<sup>67</sup> Guillermu(m) C.

<sup>68</sup> Lothoariu(m) C.

<sup>69</sup> reddiens C.

<sup>70</sup> Gimesias C.

<sup>71</sup> marcio C.

<sup>72</sup> no<n>gentesimo [*sic*] quadragesimo tercio C.

<sup>73</sup> regnante C.

<sup>74</sup> deffuncto C.

<sup>75</sup> Ricardum *om.* C.

<sup>76</sup> Guillermi C.

sed misertus est dicto Arnulpho consiliariis ipsius Ludovici muneribus excecatis, detinuitque consilio dicti Arnulphi dictum Ricardum. Quod audientes Rothomagenses processionaliter per totam Normanniam pro eo oraverunt, tandem diligentia Osmundi<sup>77</sup> ejus servitoris, faventibus Bernardo Silvanectensis comite et Hugone **[fol. 151v]** Magno duce, submovetur.

[§12] Ludovicus consulit Arnulphum quid agendum. Suadet quod Hugoni det **Normanniam a Secana usque ad mare**, residuo pro se retento, quod fecit et Hugo consentiit. Statimque Bernardus Silvanectensis hec Bernardo scilicet Rothomagensis remandavit, postquam Ludovicus in Caletto et Hugo Baiocas accesserunt cum magnis exercitibus patriam devastantes. Quod videns, Bernardus de Cygena<sup>78</sup> in dolo mandat regi ut Rothomagi veniat dominaturus ibidem, et Hugoni mandat quod<sup>79</sup> recedat a patria Normannie, quod et fecit. Normanni vero videntes quod Ludovicus eisdem dominaretur, miserunt ad Hailgrodam Dacie regem qui eorum auxilio veniens Francigenas debellavit .XVIII. comites, et Heluino computato interfecit, et regem Ludovicum cepit, qui tamen evasit, dum custodes spoliis intenderent. Postquam repetitus,<sup>80</sup> a milite Normanno Rothomagi ducitur, quamvis prius intenderet eum liberare, et †laudum ducem† regina Francorum auxilium petiit pro marito a rege Henrico ejus patre, qui omnino refutavit dicens quod merito hec paciebatur Ludovicus. Postquam consilio Hugonis Magni Ludovicus datis prius in obsidibus filio cum duobus episcopis deliberatur seu relaxatur.<sup>81</sup> Tandem idem Ludovicus totam Normanniam dicto Ricardo dimisit, a nemine nisi a solo Deo tenendum perpetuo. Qui Ricardus Radulphum<sup>82</sup>

---

<sup>77</sup> Osmondi C.

<sup>78</sup> *Probably a misreading for “Dacigena” (“Danish-born”); cf. GND, 2: 100–101.*

<sup>79</sup> ut C.

<sup>80</sup> repertus C.

<sup>81</sup> relaxamur C.

<sup>82</sup> Radulphum C.

Torta principem militie<sup>83</sup> male administrantem et domigenas ducis inedia comprimentem, sapienter a terra fugavit, †fictē† non armis sed prudentia, qui Torta Parisius ad ejus filium loci episcopum accessit.

[§13] Ricardus vero dux, qui Normanniam nulli subjectam nisi Deo tenebat, filiam Hugonis Magni ducis Parisiensis<sup>84</sup> duxit in uxorem servicio dicti Hugonis se subiciens. Quod videntes Ludovicus et Arnulphus Flandrensis, predicti Arnulphi<sup>85</sup> consilio, Ludovicus Othoni regi Trasuehnano<sup>86</sup> fratri uxoris sue totam Lothoriam dedit, ut Hugonem Magnum destrueret, sicque posset Normanniam dictus Ludovicus acquirere, que **majoris precii** et **valencie** erat quam regnum Lothoringie predictum. Qui Otho terram Hugonis usque Parisius devastavit, Rothomagum<sup>87</sup> consilio Arnulphi obsedit, sed minime profecit. Postquam Lotharius rex Francie ejusdem Ludovici filius multum dictum Ricardum infestavit. Sed dux, Dacorum auxilio, cum dicto rege obtinuit pacem et concordiam. Dacosque volentes ad fidem converti in patria ditavit, ceteros cum muneribus ad propria remisit.

[§14] Defunctaque Ricardi<sup>88</sup> uxore dicti Hugonis Magni filia, **duos filios** et **totidem filias ex concubinis** suscepit, **quorum unus Gaudefridus, alter vero** Guillelmus nuncupatur. Posteaque nobili cuidam Daci, Guinori videlicet, †ad suorum† maritali federe<sup>89</sup> copulatur, ex qua quinque filios et tres filias habuit; ecclesiam beate Marie Rothomagi, sancti Michaelis in

---

<sup>83</sup> *The passage “Tandem ... militia” is highlighted with a marginal nota in C.*

<sup>84</sup> Parisius C.

<sup>85</sup> Alnulphy C.

<sup>86</sup> Trausohenano C.

<sup>87</sup> Rothomagen' C.

<sup>88</sup> Deffunctaque Richardi C.

<sup>89</sup> feden [*sic*] C.

Monte, et sancte Trinitatis in Fiscanno mirabiliter<sup>90</sup> construxit; Arnulphum comitem Flandrie cum Lothario pacificavit. Ricardum cujus filium sibi successurum ordinavit, et in pace requievit anno Domini nongentesimo<sup>91</sup> nonagesimo sexto, sicque post patris obitum per LIII annos regnavit.

[§15] Ricardus etiam ejus filius qui *Normannicam pene patriam unam Christi* [fol. 152r] *insignivit ecclesiam*. Rusticos Normannie rebellare volentes, per Radulphum comitem castigari fecit, et *truncatis manibus* et *pedibus, inutiles*, dimisit ceteris exemplum prebens, qui *ad sua aratra sunt reversi*. *Eadem tempestate* Guillelmus ejusdem Ricardi frater ex patre, qui Guillelmus comitatum Oximensem habuerat immunis, rebellavit contra fratrem, qui captus Rothomagi per quinquennium in carcere detrusus.<sup>92</sup> Quo elapso per fenestram cum longo fune ad terram lapsus, primo voluit latitare, et tandem ad ducis pedes cadens veniam petiit, et obtinuit, ac Oximensem<sup>93</sup> comitatum reddidit,<sup>94</sup> et eidem nobilem filiam Turchetilli in uxorem tradidit<sup>95</sup> nomine Litselmam,<sup>96</sup> ex qua tres filios habuit, Robertum videlicet qui ei successit, Guillelmum Suessionem comitem, et Guillelmum Luxoviensem<sup>97</sup> presulem.

[§16] Eodem tempore rex Anglorum Aeldebredus, *Emmem ducis sororem in*<sup>98</sup> *conjugio habens*, Normanniam sibi volens subjugare, misit suos ut terram devastarent, excepto Sancto

---

<sup>90</sup> mirabilum C.

<sup>91</sup> nongentesimo om. C.

<sup>92</sup> retrusus C.

<sup>93</sup> Oximesem C.

<sup>94</sup> reddit C.

<sup>95</sup> traddidit C.

<sup>96</sup> Liselmam C.

<sup>97</sup> Luxoniensem B.

<sup>98</sup> cong scored through B.

Michaele, et regi ducem adducerent.<sup>99</sup> Qui Anglici in pago Constantiensi descendentes per milites Constantienses cum vulgo occisi sunt, quibus auditis rex erubuit *insipientiam agnoscens*.

[§17] Eo tempore Gaufridus Britannorum comes sororem dicti ducis nomine Haduis habuit in uxorem, *ex qua duos filios* suscepit, *Alanum videlicet, et Eudonem, qui post* patris obitum Britanniam<sup>100</sup> *diutius rexerunt*. Postquam rex Anglorum<sup>101</sup> <E>delredus jussit omnes Danos qui in Anglia morabantur, sine sexus<sup>102</sup> aut etatis distinctione, occidi, quod cum audisset rex Suenus Danarchie per mare veniens totam Angliam vastavit. Rex vero Anglie cum duobus filiis, Eduardo scilicet et Alvredo, Normanniam adiit cum duce Ricardo qui eum honorifice recepit. Qui rex Anglie audito obitu Sueni in Angliam venit, ibi obiit. Cui successit rex Chunitus filius Sueni. Qui Chunitus Emmam Anglorum regis<sup>103</sup> relictam in uxorem accepit, ex qua suscepit filium †pars† Hardechunutum postea Danorum regem et filiam Gumildam que Romanorum imperatori nupsit.

[§18] Eodem tempore Odo Carnotensis comes Mathildem<sup>104</sup> Ricardi ducis Normannorum sororem duxit uxorem. Cui dux dedit in dotem castrum Dorcasini<sup>105</sup> cum terra<sup>106</sup> flumine adjacente. Qua defuncta<sup>107</sup> sine liberis duci volenti terram repetere Odo contradixit nolens<sup>108</sup>

---

<sup>99</sup> aduxerunt C.

<sup>100</sup> Britaniam C.

<sup>101</sup> Analorum [sic] C.

<sup>102</sup> fefus [sic] C.

<sup>103</sup> regis Anglorum C.

<sup>104</sup> Matildam C.

<sup>105</sup> Dorchasini C.

<sup>106</sup> Blank space approximately 3.6 cm across C.

<sup>107</sup> deffuncta C.

<sup>108</sup> volens BC.

tuicionem castris Dorcasini reddere. Sed tandem tractante<sup>109</sup> Roberto rege Francorum, metu paganorum superveniencium, concordantur, sicque castrum Dorcasini remansit Odoni, terra vero et castrum Tegulense Ricardus habuit. Prefatus dux Ricardus Gaufridi<sup>110</sup> comitis Britannorum sororem nomine Judith uxorem habuit,<sup>111</sup> ex qua tres filios, Ricardum et Robertum ac Guillelmum.<sup>112</sup> Qui Ricardus eidem in ducatu<sup>113</sup> successit, et Robertus Oxomensis comitatum habuit a fratre Ricardo tenendum. Obiit autem<sup>114</sup> Ricardus secundus anno Domini millesimo XXVI<sup>o</sup>, et per XXX annos post Ricardum primum ejus patrem regnavit. Predictus vero Ricardus tercius fratrem suum Robertum comitem Oximensem<sup>115</sup> contra eum rebellantem in castro Falesie<sup>116</sup> devixit. Tandem concordia facta, [fol. 152v] veneno cum nonnullis de suis, *ut retulerunt plurimi*, obiit anno millesimo XXVIII<sup>o</sup>, sicque per duos annos dumtaxat regnavit. Cui successit Robertus ejus frater. Qui Robertus dux Robertum archipresulem exulavit, et postea revocavit. Postquam Guillelmum Belemensem<sup>117</sup>, qui ab eo castrum Alencii tenebat<sup>118</sup> rebellantem, debellavit, et dolore<sup>119</sup> *animam efflavit*.

[§19] Eodem<sup>120</sup> tempore *Balduinus satrapa Flandrensis* petiit et obtinuit pro Balduino filio suo Roberti regis<sup>121</sup> Francorum filiam. Qui Balduinus filius patrem suum a *solo pepulit*, qui

---

<sup>109</sup> tractente [sic] C.

<sup>110</sup> Goffredi C.

<sup>111</sup> accepit uxorem C.

<sup>112</sup> Guillelmum C.

<sup>113</sup> inducata C.

<sup>114</sup> aut C.

<sup>115</sup> Oxomensem C.

<sup>116</sup> Fallesie C.

<sup>117</sup> Belleme(n)sem C.

<sup>118</sup> tenebant C.

<sup>119</sup> dolose C.

<sup>120</sup> Eo C.

<sup>121</sup> regis om. C.

pater Roberti ducis Normannie <fretus auxilio> †resatum†<sup>122</sup> patrie, et cetera, et eidem<sup>123</sup> ejus filius reconciliatur.<sup>124</sup>

[§20] Eodem tempore Robertus rex Francorum moritur, cui successit Henricus, cui Henrico mater insidians eum a regno expellere nititur, et Robertum ducem Burgundionum eidem subrogare. Qui Henricus Roberti ducis Normannie fretus auxilio, adjutorio Maugerii comitis Corbulensis, reconciliantur.<sup>125</sup> Postquam Alani comitis Britonum rebellantis facto castro apud Casnon,<sup>126</sup> quod Carrucas<sup>127</sup> nuncupatur, patriam vastavit.

[§21] Eodem tempore, tractante duce Normannorum, Chunutus, qui regnum Anglie occupabat,<sup>128</sup> regni ipsius medietatem duobus filiis Alvredi<sup>129</sup> a regno expulsis reddidit, et cetera. Postquam Robertus dux Normannie<sup>130</sup> Jherosolimam petiit relicto Guillelmo<sup>131</sup> ejus filio unico, et tandem rediens<sup>132</sup> de peregrinatione in Nicena urbe anno Domini M<sup>o</sup> XXXIII<sup>o</sup><sup>133</sup> obiit, sicque per sex annos dumtaxat regnavit.

---

<sup>122</sup> refutamur C.

<sup>123</sup> eodem C.

<sup>124</sup> reconsiliatur C.

<sup>125</sup> reconsiliatur C.

<sup>126</sup> Casnun C.

<sup>127</sup> Carucas C.

<sup>128</sup> occupabat C.

<sup>129</sup> Alvredi *om.* C.

<sup>130</sup> dux Normannie Robertus C.

<sup>131</sup> Guillelmo C.

<sup>132</sup> reddiens C.

<sup>133</sup> millesimo XXXIII<sup>o</sup> C.

[§22] Guillelmus vero ejus filius ei<sup>134</sup> successit, tenerrima<sup>135</sup> tamen etate existens. Quo tempore multi ab ejus fidelitate se subtraxerunt, comes Oxensis<sup>136</sup> tutor ducis occiditur, *dolosis ortatibus Radulphi*<sup>137</sup> *de Waceyo* per manus Odonis Grossi et Roberti filii Gerouii.

[§23] Eodemque tempore *Rogerus*<sup>138</sup> *Toenites*<sup>139</sup> *de*<sup>140</sup> *stirpe Malahurcii*,<sup>141</sup> *qui Rollonis*<sup>142</sup> *ducis patruus fuerat*, noluit Guillelmo<sup>143</sup> duci obedire pro eo quod nothus erat, ymo contra eum rebellavit, omnesque vicinos suos despiciebat, et eorum terras vastabat, maxime terras Umfredi<sup>144</sup> de Vetulis. Quod tamen dictus Umfredus egre ferens suum filium Rogerum de Bellomonte *contra eum misit*, qui de Bellomonte victoriam habuit, dictusque Rogerus Toenites cum duobus filiis ibi occiduntur. Rogerus<sup>145</sup> vero de Bellomonte abbaciam de Pratellis in suo territorio fundavit, duci Normannie fidelis extitit. Duos filios, videlicet Robertum et Henricum,<sup>146</sup> ex Aelina comitis Mellentis<sup>147</sup> filia procreavit. Qui Robertus postea comes Mellentis fuit, et Henricus *dono Guillelmi*<sup>148</sup> *regis in Anglia comitatum Warelhuich*<sup>149</sup> *promeruit*. Postquam crescente Guillelmo duce Normannie Radulphus de Waceyo eidem tutor et princeps milicie Normannie constituitur.

---

<sup>134</sup> eidem C.

<sup>135</sup> peieromia [sic] C.

<sup>136</sup> Octensis C.

<sup>137</sup> Randulphi C.

<sup>138</sup> per manus ... Rogerus om. C.

<sup>139</sup> Toentes C.

<sup>140</sup> strope scored through C.

<sup>141</sup> Malahurcii C.

<sup>142</sup> Rolonis C.

<sup>143</sup> Guillermo C.

<sup>144</sup> Umfrebi BC.

<sup>145</sup> Rogerus C.

<sup>146</sup> ex Al scored through C.

<sup>147</sup> Meulentis C.

<sup>148</sup> Guillermi C.

<sup>149</sup> Wareldiche C.

[§24] Eodem tempore rex Francorum Henricus, inmemor beneficiorum sibi a duce Roberto impensorum, castrum Tegulense, Gisleberto<sup>150</sup> Crispini pro custodia comissa invicto dicto Crispini et ducis<sup>151</sup> precibus victo, cepit, et igne cremari fecit, et post hec similiter Argentonum. Postmodum Turstenus, cognomento Goz Anfridi<sup>152</sup> Dani filius, qui preses Oximensis erat, zelo infidelitatis succensus, milites stipendiis conduxit *ad muniendum Falesie*<sup>153</sup> *castellum*, sed *Radulphus Waceyensis magister militum* partem muri corruit, et tandem Turstenus aufugit et castrum dimisit. Ricardus vero ejusdem [Fol. 153r] *Tursteni filius [[duci]] optime servivit*, patrem suum reconciliavit,<sup>154</sup> et *multo majora quam pater* amiserat *acquisivit*.

[§25] Eodem tempore Malgerus frater Roberti ducis Roberto archiepiscopo Rothomagensis successit. *Nam Ricardus Gunerides mortua* uxore sua Judheit,<sup>155</sup> aliam *nomine Papiam, duxit, ex qua* dictum Malgerum, et Guillelmum Archacensem, cui Guillelmo Archasensi dux Guillelmus<sup>156</sup> ejus nepos comitatum Talogi, ut inde illi serviret, concessit. Ipse vero [[G.]] Archacensis *castrum Archiarum in cacumine montis condidit*, et post hec Guillelmo<sup>157</sup> duci rebellavit. Dux vero pro ipso mandavit ad hoc ut exhiberet servicium, quod facere recusavit. Dux autem *ad radicem montis castrum stabilivit*, ac adjutorio Henrici regis non obstante, prefatus Guillelmus predicto Guillelmo<sup>158</sup> duci dictum castrum dimisit.

---

<sup>150</sup> Gilberto C.

<sup>151</sup> prei scored through C.

<sup>152</sup> Gaufridi BC.

<sup>153</sup> Fallesie C.

<sup>154</sup> reconsiliavit C.

<sup>155</sup> Judith om. and a blank space approximately 4.2 cm across C.

<sup>156</sup> Guillermus C.

<sup>157</sup> Guillermo C.

<sup>158</sup> Guillermus predicto Guillermo C.

[§26] Eodem tempore rex Anglie Chunutus obiit, *cui successit Heroldus ejus filius ex concubina natus. Cujus* Chunuti<sup>159</sup> Eduardus<sup>160</sup> *audiens* obitum, *adhuc cum duce* Guillelmo<sup>161</sup> *degens cum XL*<sup>162</sup> *navibus militibus plenis, Hamtornam appulit*, et ibi multitudinem Anglorum offendit, et in Normannia cum preda rediit.<sup>163</sup> Interea frater ejus Alvredus *Doroberniam venit* et *Goduinum comitem obvium habuit, quem* Alvredum *idem comes in sua fide* suscepit. Et post eadem nocte eum ligatis manibus **Heroldo**<sup>164</sup> *regi apud Londoniam* destinavit, cui oculos<sup>165</sup> crepuit et suis militibus capita amputari fecit. Statim post Heroldus obiit, *cui successit frater ejus Hardechunutus a Dacia egressus, ex Emma, Eduuardi*<sup>166</sup> *matre, natus, qui post paululum confirmatus in culmine regni fratrem suum Eduuardum a Normannia revocavit ac secum cohabitare*<sup>167</sup> *fecit*, quo Hardechunuto mortuo *Eduardum*<sup>168</sup> *totius regni* Anglie heredem<sup>169</sup> reliquit. Qui Gaduino remisit perniciem ejus fratrem perpetrata, rexitque regnum Anglorum fere XXIII<sup>bus</sup> annis.

[§27] Post hec Guillelmus<sup>170</sup> dux Guillelmum, *cognomento Werlencus*, comitem Moritolii, a Normannia exulavit, et dux comitatum Moritomensem Roberto fratri suo concessit. Postea vero Guillelmus<sup>171</sup> Busacius<sup>172</sup> volens subjugare ducatum a Guillelmo duce exulare cogitur.

---

<sup>159</sup> d scored through B.

<sup>160</sup> Eduardus C.

<sup>161</sup> Guillermo C.

<sup>162</sup> XL<sup>ta</sup> C.

<sup>163</sup> reddiit C.

<sup>164</sup> Heroldi C.

<sup>165</sup> oculos C.

<sup>166</sup> Eduardi C.

<sup>167</sup> **coheritare BC.**

<sup>168</sup> Eduardum C.

<sup>169</sup> heredem totius regni Anglie C.

<sup>170</sup> Guillermus C.

[§28] Hoc tempore dux filiam Balduini Flandrensis<sup>173</sup> sibi uxorem copulavit, que ejus erat consanguinea, sed postea a papa dispensacionem obtinuit, et ob hoc duas ecclesias in Cadomo fundaverunt. Postmodumque videlicet anno M<sup>o</sup> LIII<sup>o</sup><sup>174</sup> rex Francie Henricus unctus, Normanniam<sup>175</sup> infestat, dicens quod Normanni<sup>176</sup> per violenciam hanc patriam sibi vendicaverant sed dux fortiter obstitit.

[§29] Postea vero Eduardus<sup>177</sup> rex Anglie obiit sine prole, qui antea Guillelmum ducem sibi heredem instituerat sibi que Heraldum miserat qui eidem duci fidelitatem de regno Anglie fecit. Dux vero *eidem Adelizam filiam suam cum medietate regni Anglici se daturum spopondit*,<sup>178</sup> et eum in Anglia retento Vulnoto ejus fratre in obside remisit. Mortuo vero dicto Eduardo<sup>179</sup> regi anno Domini M<sup>o</sup> LXV<sup>o</sup><sup>180</sup> Heraldus continuo<sup>181</sup> regnum invasit contra fidem quam duci federat,<sup>182</sup> ut est tactum.

[Fol. 153v] [§30] Eodem tempore apparuit<sup>183</sup> cometes in partibus illis que mutacionem regni alicujus, ut plurimi asseruerunt, designavit.

---

<sup>171</sup> Guillermus C.

<sup>172</sup> Buffacius B.

<sup>173</sup> Flandresis C.

<sup>174</sup> IIIII<sup>o</sup> B; millesimo IIII<sup>o</sup> C.

<sup>175</sup> unctum Normannia C.

<sup>176</sup> Normanniam C.

<sup>177</sup> Eduardus C.

<sup>178</sup> spondidit C.

<sup>179</sup> Eduardo C.

<sup>180</sup> millesimo LX<sup>to</sup> C.

<sup>181</sup> continue BC.

<sup>182</sup> fecerat C.

<sup>183</sup> operuit C.

[§31] Eodem anno M<sup>o</sup> LXV<sup>o</sup><sup>184</sup> Guillelmus dux Normannie per Chunanum comitem Britannie *aliquantulum territus est*, petiit enim sibi reddi Normanniam aut bellum inferre promisit. Sicque Guillelmus<sup>185</sup> effectus securus *classem ad tria milia navium festinanter* construi fecit, et *in Pontivo apud Sanctum Walericum*<sup>186</sup> *congrue stare fecit. Ingentem quoque exercitum* ex *Normannis, Flandrensibus, Francis et Britonibus aggregavit*, et *trans mare Pevevessellum appulit, ubi* castrum unum, et deinde apud Hastingas<sup>187</sup> aliud firmavit. Tunc enim Heroldus<sup>188</sup> in<sup>189</sup> guerra quam contra Tostium fratrem suum [[habebat erat occupatus in qua guerra fratrem suum]] et regem Northime congrue occidit. Statimque auditis novis de ingressu ducis Normannorum contra <consilium> matris et fratris sui Worth comitis *per sex dies innumeram Anglorum multitudinem* congregavit. Dux vero exercitum suum et legiones *militum in tribus ordinibus* disposuit, et *horrendo hosti intrepidus*<sup>190</sup> *hora diei tertia* diluculo sabbati obviam processit, et bellum commisit usque ad noctem. Ibique in primo congressu Heroldus<sup>191</sup> letaliter vulneratus occubuit. Angli vero de nocte fugientes a Normannis insequuntur, ibique *XV milia perierunt* de iudice. *Idem quoque iudex* nocte sequentis dominice *Anglos vindicavit*. Anno itaque Domini M<sup>o</sup><sup>192</sup> LXVI<sup>o</sup> <Guillelmus dux> in regem *ab omnibus tam Normannorum quam Anglorum* est *electus* et *sacro oleo ab episcopis regni delibutus*<sup>193</sup> atque *regali diademate coronatus*. Locus vero ille in quo bellum

---

<sup>184</sup> millesimo LXV<sup>to</sup> C.

<sup>185</sup> Guillermus C.

<sup>186</sup> Wallericum C.

<sup>187</sup> Hastingas C.

<sup>188</sup> Heraldus C.

<sup>189</sup> terra scored through C.

<sup>190</sup> in crepibus [sic] C.

<sup>191</sup> Heraldus C.

<sup>192</sup> millesimo C.

<sup>193</sup> deliberatus scored through and delibatus C.

fuit usque hodie Bellum nuncupatur, in quo rex Guillelmus<sup>194</sup> cenobium in Sancte Trinitatis honore construxit. Et in Normanniam rediens<sup>195</sup> ecclesiam Sancte Marie in Gemetico dedicari fecit, et Roberto filio suo ducatum Normannie tradidit, et Angliam revertitur ibique plurimos qui *in capite jejunii* fideles omnes regis occidere proposuerant debellavit.

---

<sup>194</sup> Guillelmus C.

<sup>195</sup> reddiens C.

## TRANSLATION

[Fol. 150r] Short [and] succinct chronicle of the dukes of Normandy.

[§1] The *Daci* pride themselves on being descended from Antenor. Hasting, leader of the Dacians, landed with his men in Francia and devastated it. Afterwards he journeyed to conquer Rome, and through a ruse by which he pretended to be dead seized the town of Lunx, known as Luna; and bragging that he had captured Rome, but discovering that the opposite was in fact the case, he burned it down, and returned to Francia, and made peace with the king of the Franks through the receiving of gifts. Meanwhile, the king of Dacia wanted to expel many of his [own] men from his realm. Rollo and Gurim, sons of a most powerful Dacian leader, who had acquired for himself almost all of Dacia, opposed this expulsion at the request of the aforementioned youths.<sup>196</sup> The king of Dacia marched against them, yet they achieved victory on this occasion. But the next day Gurim was deceitfully slain in battle, and Rollo was put to flight; this [same] Rollo landed on the island of Scanza with six ships and proceeded to the English after having been advised [to do so] in a dream.

[§2] The form of the advice was thus: “Rollo, rise up with speed and make haste to sail across the sea and go to the English. There you will hear how you will return to your own country as a saviour, and will there enjoy perpetual peace, free from harm”. Which dream was interpreted by a wise Christian man as follows:

---

<sup>196</sup> The “aforementioned youths” mentioned here are those young men, who, according to Dudo, were singled out by the king of Dacia for expulsion from his realm, and who subsequently went to Rollo and Gurim for help (*HN*, 141–43).

[§3] “In due course, you will be purified by holy baptism, and you will become a most worthy Christian: and by wandering the uncertain world you will come to the Angles, and with them you will enjoy the peace of everlasting glory”.<sup>197</sup> And straightaway he subjugated certain Angles by his authority, and, [as] foretold earlier by the dream, [made] a treaty with Æthelstan, king of the English.<sup>198</sup> He arrived at Walcheren,<sup>199</sup> notwithstanding the perils of the sea, and devastated that land and Frisia, and imposed tribute. And he captured Rainer [Longneck],<sup>200</sup> and then let him go. And in the year 876 after the incarnation of the Lord, he went to Jumièges via the [River] Seine,<sup>201</sup> and in the church of St Vedast he placed the body of St Hameltrude on the altar and built a chapel in the name of the same saint in that place. He entered Rouen without difficulty through the gate of St Martin after he had given assurances to its inhabitants, and he chose to settle in these parts.

[§4] He went to [Pont-de-l’]Arche,<sup>202</sup> thereafter occupied Meulan,<sup>203</sup> besieged Paris and captured Bayeux,<sup>204</sup> which he conquered, and accepted the daughter of Prince Berengar in marriage,<sup>205</sup> from whom he received William.<sup>206</sup> He then returned to Paris, conquered it whilst sending some of his men to Évreux,<sup>207</sup> and returned to Paris.<sup>208</sup> Learning that Rollo

---

<sup>197</sup> The text here misses the pun likening the English/Angles to angels (“ad Anglos, scilicet angelos”) that goes back to a story about St Gregory related by Bede and features in both the *HN* and the *GND* (*HN*, 145; *GND*, 1: 38–39).

<sup>198</sup> Æthelstan, king of the Anglo-Saxons (924–27), king of the English (927–39).

<sup>199</sup> Walcheren is a region and former island in the modern Dutch province of Zeeland at the mouth of the Scheldt estuary.

<sup>200</sup> Rainer Longneck, duke of Hesbaye († 915).

<sup>201</sup> Jumièges, Seine-Maritime, cant. Barentin.

<sup>202</sup> Pont-de-l’Arche, Eure, chef-lieu de cant.

<sup>203</sup> Meulan, Yvelines, cant. Les Mureaux.

<sup>204</sup> Bayeux, Calvados, chef-lieu de cant.

<sup>205</sup> Berengar, count [probably of Maine] (*fl.* 891×895).

<sup>206</sup> William Longsword, later duke of Normandy (928×933–42).

<sup>207</sup> Évreux, Eure, chef-lieu de cant.

had laid siege to Paris, the English rebelled against their king Æthelstan, who asked and received the help of Rollo, and gave Rollo half of the kingdom so he would subjugate the rebels; once these had been brought under the yoke by the aforesaid Rollo and were reconciled [with the king], half of the kingdom and the culprits [as hostages] were given to the same Rollo; but Rollo gave it [*sic*] back, asking only that he [the king] should not prohibit those who preferred to follow him. Agreeing to this, the king wanted to accompany him to France. Rollo, who had returned to France, refused this, however, and divided his army.

[§5] King Charles<sup>209</sup> requested and obtained a truce with him [Rollo] by mediation of Franco, archbishop of Rouen,<sup>210</sup> which lasted for three months, at the end of which the Burgundians and the Franks resumed war against Rollo on the advice of Richard [duke of the Burgundians] and Ebalus [count of Poitou].<sup>211</sup> Rollo, meanwhile, mutilated France and devastated the lands as far as Clermont-[Ferrand] via Saint-Benoît,<sup>212</sup> which he spared from ruin. He devastated Étampes,<sup>213</sup> and en route back to Paris he vanquished the rural population and besieged Chartres.<sup>214</sup> [Fol. 150v] Here he fought a fierce battle with the Franks and Burgundians until a bishop joined the battle with a cross and arms, and Rollo withdrew from the army in order to avoid death. Ebalus, who had not taken part in the battle, pursued the

---

<sup>208</sup> It would appear that “Lontessia” (B) and “Lentessia” (C) are corrupted versions of “Lutetia”/“Loticia”, the Roman name(s) for Paris.

<sup>209</sup> Charles the Simple, king of West Francia (898–922).

<sup>210</sup> The existence of Franco, archbishop of Rouen, who is traditionally said to have reigned from c.911–19 is disputed. For discussion, see Richard Allen, “The Norman Episcopate, 989–1110,” unpublished doctoral thesis (University of Glasgow, 2009), 1: 15–20.

<sup>211</sup> Richard, duke of Burgundy (898–921); Ebalus, count of Poitou (890–92).

<sup>212</sup> Clermont-Ferrand, Puy-de-Dôme, chef-lieu de cant.; Saint-Benoît-sur-Loire, Loiret, cant. Sully-sur-Loire.

<sup>213</sup> Étampes, Essonne, chef-lieu de cant.

<sup>214</sup> Chartres, Eure-et-Loir, chef-lieu de cant.

army of the heathens to Mount Lèves,<sup>215</sup> but to no avail. Rollo seized and completely devastated the entire country. The Franks asked [their king] Charles to make peace with Rollo and give him his daughter, Gisla, as well as the land between the River Epte and the sea, which was done by intervention of Franco, archbishop of Rouen. And Rollo was received by Duke Robert<sup>216</sup> from the sacred font, a treaty first being made, by which he conceded Brittany until the aforementioned land would be cultivated, Flanders having been rejected as too boggy. Moreover, he [Rollo] did not want to kiss the king's foot, but [instead] instructed a soldier [to do so], who tipped the king on his back. And thus Rollo was baptised in the year of the incarnation [of the Lord] 912 and christened Robert in the sacred font, and just as he had devastated [this] country for thirty-six years between his arrival and his baptism, having accepted baptism he [now] endowed churches, divided what was left over amongst his people, and afterwards took the aforementioned Gisla as his wife. He granted the people rights and everlasting laws, sanctioned and decreed by the will of their leaders. He subjugated the insurgent Bretons and forbade theft.

[§6] The legates of King Charles who, unbeknownst to Rollo, had been meeting [secretly] with his wife for some time, he had executed publicly by cutting their throats. When Robert, duke of the Franks, learned that the bonds of peace [between Rollo and King Charles] had been disrupted thus, he rose against King Charles and sent envoys to Robert, who previously had been known as Rollo of Rouen, saying he wanted to fight Charles and obtain the kingdom of the Franks for himself. Robert of Rouen responded to this that he [Duke Robert of the Franks] was too eager to ride out and act beyond the law, but nevertheless the aforementioned duke of the Franks rebelled against the king and had himself anointed king

---

<sup>215</sup> Lèves, Eure-et-Loir, cant. Chartres-3.

<sup>216</sup> Robert, count of Poitiers and Paris, subsequently king of West Francia (922–23).

on 29 June. King Charles regained the kingdom before the end of the [same] year, however, and he killed the aforementioned duke. Yet Count Herbert [II of Vermandois]<sup>217</sup> captured Charles himself and detained him in the castle of Péronne until his death.<sup>218</sup> He [Charles] was succeeded by Ralph, son of Richard, duke of Burgundy,<sup>219</sup> and godson of the said Charles, and the wife of the said Charles fled to her father, the king of England, together with their son, Louis, because she was too scared by the hostility of Herbert and Hugh the Great,<sup>220</sup> son of the aforementioned Duke Robert of the Franks.

[§7] Following the death of his wife, Rollo returned to and reunited himself with Popa, by whom he had [previously] been given his son, William. Summoning the Normans and Bretons, he presented the said William to them, placed him in charge of them as their lord, and subjugated them to his son by [making them swear] an oath of fealty. From then on, he lived as an old man consumed by sin, and [eventually] abandoned his mortal shell in Christ.

[§8] After the death of Rollo, his and Popa's son, William, had been commended to the wealthy Count Botho for his education,<sup>221</sup> and he had wanted to become a monk at Jumièges, which he wished to promote in the most generous fashion. He subdued the Bretons who rebelled against him but retained their duke, Berengar,<sup>222</sup> as bound to him by his oath of

---

<sup>217</sup> Herbert II, count of Vermandois (907–43).

<sup>218</sup> Péronne, Somme, chef-lieu de cant.

<sup>219</sup> Ralph, king of the Franks (923–36).

<sup>220</sup> Hugh the Great, duke of the Franks and count of Paris (c.898–956).

<sup>221</sup> Botho, so-called “count of Bayeux” (“comes Baiocensis”); cf. *GND*, 1: 78 n. 3.

<sup>222</sup> Judicael Berengar, count of Rennes (c.930–c.970).

fealty and service, and drove off Alan,<sup>223</sup> who went to England. This William accepted a wife,<sup>224</sup> and reconciled himself with Hugh the Great and Herbert [II of Vermandois].

[§9] After this, the perfidious Riulf rebelled against him,<sup>225</sup> whom he vanquished, along with his accomplices, at Pré-de-la-Bataille near Rouen.<sup>226</sup> And, returning from the battle, **[Fol. 151r]** he had news of his son's birth, who was thus raised so that the Franks, Burgundians, Flemish, English, Danes and Irish obeyed him. He [Duke William] married his daughter [*sic*] to William of Poitou. Herbert gave his daughter, on the advice of Duke Hugh the Great, to William of Rouen as his wife. Æthelstan, king of England, sent legates with gifts to this same William, begging that Louis,<sup>227</sup> his nephew, and Æthelstan [*sic*], son of the aforesaid Charles, king of France, might be recalled to the Frankish realm, and that he might receive Alan, [who had been] expelled from Brittany for [his] crimes. And immediately, on the advice of the aforesaid William, Duke Hugh the Great and Herbert, leader of the princes, with the approval of the bishops and the advice of the metropolitans, promptly recalled the aforesaid Louis and anointed him king for themselves, [to rule] over the people living in Francia and Burgundy. And for the love of King Æthelstan, William received Alan, who had returned with Louis.

---

<sup>223</sup> Alan II, duke of Brittany (936–52).

<sup>224</sup> This is a reference to Liutgard, daughter of Heribert II, count of Vermandois; cf. *GND*, 1: 80.

<sup>225</sup> According to Wace's *Roman de Rou*, Riulf was "count of the Cotentin between the Vire and the sea" ("Quens fu de Costentin entre Vire è la mer"), but his origins are unknown. His name would suggest that he was French; Anthony J. Holden, ed., *Le Roman de Rou de Wace* (Paris, 1970), 1: l. 1376; also cf. Glyn S. Burgess, ed./tr., *The History of the Norman People: Wace's Roman de Rou* (Woodbridge, 2004), 36 n. 57.

<sup>226</sup> The battlefield, whose name exists today in the modern street name of rue du Pré-de-la-Bataille, was located to the west of the Norman capital.

<sup>227</sup> Louis IV d'Outremer, king of the Franks (936–54).

[§10] But after five years had passed, the Franks began to rebel against Louis, who, beseeching Henry, king of the land beyond the Rhine,<sup>228</sup> [was told] that help could not be obtained except through William's mediation. With this, the aforesaid Louis stayed for a long time with William at Rouen, and this same William sent messengers to the aforesaid King Henry in order to procure peace; this [same] King Henry sent these messengers back, and with them Duke Conan<sup>229</sup> as a hostage to bring about peace, whom William did not want to retain, but took with him to a meeting with Louis, king of the Franks, in the district of Laon,<sup>230</sup> face to face with Hugh and Herbert, and there kings Henry and Louis joined in alliance, in Hugh and Herbert's presence but not, however, with their consent. And hearing that unto him a son had been born, namely by his wife, Gerberga, he [Louis] made William lift him from the holy font and call him Lothar.<sup>231</sup> Having done this, William, upon returning home, built the admirably-designed church at Jumièges, and asked Martin, abbot of that place:<sup>232</sup> "Why are there three orders of Christians in the church?". He declared that he wanted in every respect to become a monk at that place, and the Normans and Bretons submitted themselves through fealty to Richard,<sup>233</sup> his son. Afterwards, Arnulf, lord of Flanders,<sup>234</sup> seized the castle of Herluin,<sup>235</sup> which is called Montreuil,<sup>236</sup> this [same] Herluin at first asked for help from Duke Hugh, and, having been refused, obtained assistance from Duke William, through which he recovered the aforesaid castle.

---

<sup>228</sup> Henry I, king of East Francia (919–36).

<sup>229</sup> Conan, so-called "duke of the Saxons" ("dux Saxonum"); cf. *HN*, 195 n. (b).

<sup>230</sup> Laon, Aisne, chef-lieu de cant.

<sup>231</sup> Later Lothar, king of the Franks (954–86).

<sup>232</sup> Martin, abbot of Jumièges (938–43).

<sup>233</sup> Later Richard I, duke of Normandy (942–96).

<sup>234</sup> Arnulf I, count of Flanders (918–65).

<sup>235</sup> Herluin II, count of Montreuil (926–45).

<sup>236</sup> Montreuil, Seine-Saint-Denis, chef-lieu de cant.

[§11] Arnulph thus secured a peace of three months with William, [and] they came together at a meeting in which William was killed through betrayal and deceitfulness by Arnulf, in the year of the incarnation of the Lord 943, on 17 December, while King Louis held the kingdom of the Franks. With his death, the Bretons and Normans established Richard, his son, as duke. Hearing of William's death, [King] Louis came to Rouen and retained the boy Richard. He displeased the citizens [of Rouen], and they impeded [him], and he [Louis] then kept him [Richard] to be educated. And Louis pretended to want to capture Arras<sup>237</sup> and to destroy Arnulf, but with Louis's counsellors blinded by gifts, he had mercy on the said Arnulf, and, on Arnulf's advice, he detained Richard. On hearing this, the Rouennais prayed for him in processions throughout Normandy, and then, through the diligence of Osmond, [the duke's] servant, [and] with the support of Bernard, count of Senlis,<sup>238</sup> and Duke Hugh [Fol. 151v] the Great, he [Richard] was carried off.

[§12] Louis consulted Arnulf on what to do. He proposed that [Louis] give Normandy from the Seine to the sea to Hugh, retaining the rest for himself, to which Hugh agreed and it was done. And Bernard of Senlis immediately sent word to Bernard of Rouen,<sup>239</sup> [and] thereafter Louis and Hugh came to the Pays-de-Caux and the Pays-de-Bayeux with great armies, devastating the land. Seeing this, Bernard of [Cygena] cunningly asked the king to come to Rouen to rule over that place, and he [Louis] sent word to Hugh to withdraw from Normandy, which was done. The Normans, seeing that this same Louis was to rule, sent word to Harold, king of Dacia,<sup>240</sup> who, coming to their aid, vanquished eighteen Frankish counts, killed [Count] Herluin and captured King Louis, who then escaped his guards, [who] were

---

<sup>237</sup> Arras, Pas-de-Calais, chef-lieu de cant.

<sup>238</sup> Bernard, count of Senlis (c.917–c.947); cf. *GND*, 1: 105 n. 5.

<sup>239</sup> Bernard “the Dane” (“Bernardus Dacigena”); cf. *GND*, 2: 100–101; *HN*, 225.

<sup>240</sup> Harald I Bluetooth, king of the Danes (958/9–985/6).

intent on booty. He was later captured and taken to Rouen by a Norman soldier, even though he at first intended to free him, and [laudum ducem]<sup>241</sup> the queen of the Franks begged her father, King Henry, to help her husband, who refused entirely, saying that Louis deserved to suffer this. Afterwards, on the advice of Hugh the Great, Louis resolved first to give his son as hostage, along with two bishops, in order to be freed. Then, this same Louis handed over all of Normandy to the said Richard, to be held in perpetuity from no one save God; this [same] Richard wisely drove from the land, not through [the force of] arms but with prudence, Rodulf Torta, head of the army, [who] administered wickedly and repressed the ducal household with starvation, and this [same] Torta went to Paris where his son was bishop of the place.

[§13] Duke Richard, who was holding Normandy subject to no one except God, took as his wife the daughter of Hugh the Great, duke of Paris, subjecting himself to the said Hugh's service. Louis and Arnulf of Flanders having seen this, Louis, on the advice of the aforesaid Arnulf, gave all Lotharingia to Otto, king of the land beyond the Rhine,<sup>242</sup> his wife's brother, so that he [Otto] might destroy Hugh the Great, and so that the said Louis might be able to acquire Normandy, which was of much greater value and strength than the aforesaid kingdom of Lotharingia. That same Otto laid waste to Hugh's land up to Paris and, on Arnulf's advice, besieged Rouen, but accomplished very little. Afterwards, Lothar, king of France, son of the same Louis, greatly harassed the said Richard. But the duke, with the help of the Dacians, obtained peace and harmony with the aforesaid king. And those Dacians who wanted to

---

<sup>241</sup> It has not been possible to arrive at a workable translation of these two words. It is possible that they are governed by the verb liberare, but the resulting translation makes little sense in the context of the narrative at this point.

<sup>242</sup> Otto I, king of East Francia (936–73), Holy Roman Emperor (962–73).

convert to the [true] faith he [kept and] enriched in his country, while sending the others back to their own [land] laden with gifts.

[§14] With the death of Richard's wife, daughter of Hugh the Great, he [then] had two sons and the same number of daughters by concubines, one of whom was Geoffrey, [while] the other was called William.<sup>243</sup> And thereafter he joined to himself by the bonds of matrimony a certain noble Dacian, namely Gunnor, by whom he had five sons and three daughters; he marvellously built the church[es] of St Mary at Rouen, Mont Saint-Michel and Holy Trinity at Fécamp; he reconciled Arnulf, count of Flanders,<sup>244</sup> with [King] Lothar. He ordained his son Richard as his successor and died in peace in the year of the Lord 996, so that he reigned for fifty-three years after the death of his father.

[§15] Likewise, his son Richard,<sup>245</sup> who made the Norman fatherland an almost united church of Christ, [**Fol. 152r**] punished the peasants of Normandy, who were wanting to rebel, through Count Rodulf,<sup>246</sup> and sent back [their] dismembered hands and feet, no longer of any use, as an example to the others, who returned to their ploughs. At the same time, William, paternal brother of the same Richard, who had held the county of Hiémois as a gift, rebelled against his brother, [and] was captured at Rouen and thrown into imprisonment for five years. After this had passed, he dropped from a window to the ground by a long rope. At first, he wanted to hide, and then begged pardon falling at the duke's feet, and obtaining this he was restored to the county of Eu,<sup>247</sup> and took as a wife a noble daughter of Turketil, called

---

<sup>243</sup> Geoffrey, count of Eu and Brionne, and William, count of Eu († before 1040).

<sup>244</sup> Arnulf II, count of Flanders (965–87).

<sup>245</sup> Richard II, duke of Normandy (996–1026).

<sup>246</sup> Rodulf, count of Ivry († after 1011).

<sup>247</sup> Eu, Seine-Maritime, chef-lieu de cant.

Lescelina,<sup>248</sup> by whom he had three sons, namely Robert, who succeeded him, William, count of Soissons,<sup>249</sup> and William [*sic*],<sup>250</sup> bishop of Lisieux.

[§16] At that same time, Æthelred, king of the English,<sup>251</sup> who was married to the duke's sister, was wanting to subjugate Normandy, [and] sent his men so that they might devastate the land, apart from Mont Saint-Michel, and bring the duke back [to England]. Descending on the district of the Cotentin, these English were killed by knights of the Cotentin and the common people. Hearing this [and] realising his folly, the king blushed with shame.

[§17] At that time, Geoffrey, count of the Bretons,<sup>252</sup> had as a wife the aforesaid duke's sister, named Hawisa, by whom he had two sons, namely Alan and Odo,<sup>253</sup> who after their father's death ruled Brittany for a long time. Afterwards, Æthelred, king of the English, ordered that all the Danes living in England, regardless of sex or age, be killed. When King Svein of Denmark heard this,<sup>254</sup> he crossed the sea and laid waste to all England. The king of England came to Normandy with two of his sons, namely Edward and Alfred,<sup>255</sup> where they were received with honour by Duke Richard. This same king of England, on hearing of Svein's death, went [back] to England, where he died. He was succeeded by Cnut, son of

---

<sup>248</sup> Lescelina, daughter of Turketil († 1058).

<sup>249</sup> William Busac, count of Soissons (1057–76).

<sup>250</sup> The text here mistakenly identifies Count William I of Eu's third son, Hugh, bishop of Lisieux (1049–77), as William; cf. *GND*, 2: 11 n. 6.

<sup>251</sup> Æthelred II the Unready, king of the English (978–1013).

<sup>252</sup> Geoffrey I, duke of Brittany (992–1008).

<sup>253</sup> Alan, later duke of Brittany (1008–40) and Odo, later count of Penthièvre (1035–79).

<sup>254</sup> Svein I Forkbeard, king of the Danes (986–1014).

<sup>255</sup> Alfred Aetheling (c.1005–36) and Edward the Confessor, later king of England (1042–66).

Svein;<sup>256</sup> this [same] Cnut took as his wife Emma,<sup>257</sup> widow of the king of the English, by whom he had a son, Harthacnut, later king of the Danes,<sup>258</sup> and a daughter, Gunnhild, who married the emperor of the Romans.<sup>259</sup>

[§18] At that same time, Odo, count of Chartres,<sup>260</sup> took for a wife Mathilda, sister of Richard, duke of the Normans. The duke gave him as dowry the castle of Dreux with the land adjacent to the river.<sup>261</sup> When she died without children, the duke wanted the land to be returned, [but] Odo refused, not wanting to hand over the guardianship of the castle of Dreux. But they were then reconciled, at the urging of Robert, king of the Franks,<sup>262</sup> [who was] fearful of the approaching pagans,<sup>263</sup> so that he [the duke] returned the castle of Dreux to Odo, [while] Richard had the land and castle of Tillières.<sup>264</sup> The aforesaid Duke Richard had as [his] wife the sister of Geoffrey, count of the Bretons, from whom [were born] three sons, Richard, Robert and William,<sup>265</sup> [of whom] Richard succeeded him in the duchy, and Robert had the county of Hiémois, to be held from Richard, his brother. Richard the second died in the year of the Lord 1026, [having] reigned for thirty years after his father, Richard the first. The aforesaid Richard the third constrained his brother Robert, count of the Hiémois, [who

---

<sup>256</sup> Cnut the Great, king of England (1016–35).

<sup>257</sup> Emma of Normandy (984–1052).

<sup>258</sup> Harthacnut, king of the Danes (1035–42).

<sup>259</sup> Gunhild was the wife of Henry III, Holy Roman Emperor (1046–56).

<sup>260</sup> Odo II de Blois, count of Chartres (1004–23).

<sup>261</sup> Dreux, Eure-et-Loir, chef-lieu de cant.

<sup>262</sup> Robert II the Pious, king of the Franks (996–1031).

<sup>263</sup> This is a reference to Olaf of the Norsemen and Lacaman of the Swedes who, according to the *GND*, came from their native lands at the request of Duke Richard to help him in his dispute with Odo of Chartres (*GND*, 2: 24).

<sup>264</sup> Tillières-sur-Avre, Eure, cant. Verneuil-sur-Avre.

<sup>265</sup> Richard III, duke of Normandy (1026–27); Robert I, duke of Normandy (1027–35); William, later a monk at Fécamp († 1025).

was] rebelling against him, in the castle of Falaise.<sup>266</sup> Then, when peace was made, **[Fol. 152v]** he died of poison, with many of his men, as some people say, in the year 1028, having reigned for no more than two years.<sup>267</sup> He was succeeded by Robert, his brother; this [same] Duke Robert exiled Archbishop Robert,<sup>268</sup> and later recalled him. Afterwards, he vanquished the rebellious William of Bellême,<sup>269</sup> who was holding the castle of Alençon from him,<sup>270</sup> and [who] died of grief.

[§19] At that same time, Count Baldwin [IV] of Flanders<sup>271</sup> requested and obtained the daughter of Robert, king of the Franks, for his son, Baldwin [V];<sup>272</sup> this [same] son Baldwin drove his father from his own lands, and this [same] father [supported by the help] of Robert, duke of Normandy, was restored to his land, etcetera, and his son reconciled to him.

[§20] At that same time, Robert, king of the Franks, died and was succeeded by Henry,<sup>273</sup> whose mother treacherously plotted to expel him from the kingdom and replace him with Robert, duke of the Burgundians;<sup>274</sup> this [same] Henry was supported by the help of Robert, duke of Normandy, [and], with the assistance of Mauger, count of Corbeil,<sup>275</sup> they [Henry and his mother] were reconciled. Afterwards, he [Duke Robert] laid waste to the land of the

---

<sup>266</sup> Falaise, Calvados, chef-lieu de cant.

<sup>267</sup> In reality, Duke Richard III of Normandy only ruled for slightly less than one year (28 August 1026–6 August 1027).

<sup>268</sup> Robert, archbishop of Rouen (c.989–1037).

<sup>269</sup> William I de Bellême (c.1005–c.1031/35).

<sup>270</sup> Alençon, Orne, chef-lieu de cant.

<sup>271</sup> Baldwin IV, count of Flanders (987–1035).

<sup>272</sup> Baldwin V, count of Flanders (1035–67).

<sup>273</sup> Henry I, king of the Franks (1031–60).

<sup>274</sup> Robert I, duke of Burgundy (1032–76).

<sup>275</sup> Mauger, count of Corbeil (c.963–1040).

rebellious Alan, count of the Bretons, having built a castle, known as Cherrueix,<sup>276</sup> upon the [River] Couesnon.

[§21] At that same time, Cnut, who had seized the kingdom of England, returned half of his own kingdom, at the urging of the duke of the Normans, to the two sons of Æthelred, who had been expelled from the realm, etcetera. Robert, duke of Normandy, having made for Jerusalem and leaving behind William as his only son, died while staying abroad in the city of Nicaea in the year of the Lord 1035, thus having reigned for only six years.<sup>277</sup>

[§22] His son, William,<sup>278</sup> succeeded him, but because he was still of tender age at that time many withdrew their fidelity from him, and the count of Eu, the duke's tutor, was killed through the cunning exhortations of Rodulf of Gacé<sup>279</sup> by the hands of Odo the Fat and Robert, sons of Giroie.

[§23] At that same time, Roger of Tosny,<sup>280</sup> a descendant of Malahulc, who was the paternal uncle of Duke Rollo, refused to obey [Duke] William because he [William] was a bastard, and indeed he rebelled against him, despised all his neighbours and devastated their lands, most of all the lands of Humphrey of Vieilles;<sup>281</sup> this said Humphrey, however, reluctantly sent his own son, Roger of Beaumont,<sup>282</sup> against him; this [same Roger] of Beaumont achieved victory, and the said Roger of Tosny and his two sons were killed. Roger of

---

<sup>276</sup> Cherrueix, Ille-et-Vilaine, cant. Dol-de-Bretagne.

<sup>277</sup> In reality, Duke Robert I of Normandy ruled for almost eight years (autumn 1027–July 1035).

<sup>278</sup> William the Conqueror, duke of Normandy (1035–87) and king of England (1066–87).

<sup>279</sup> Gacé. Orne, cant. Vimoutiers.

<sup>280</sup> Roger I de Tosny († c.1040). Tosny, Eure, cant. Gaillon.

<sup>281</sup> Humphrey of Vieilles († c.1050).

<sup>282</sup> Roger of Beaumont († after 1090). Beaumont-le-Roger, Eure, Brionne.

Beaumont, meanwhile, founded the abbey of Préaux<sup>283</sup> in his own territory and proved himself a loyal subject of the duke of Normandy; two children were born unto him by Adelina, daughter of the count of Meulan, namely Robert and Henry. This [same] Robert was later count of Meulan,<sup>284</sup> and Henry earned himself the county of Warwick<sup>285</sup> in England by gift of King William. Rodulf of Gacé subsequently ascended under William, duke of Normandy, by being made his tutor and chief commander of the Norman army.

[§24] At that same time, Henry, king of the Franks, forgetful of the support given to him by Duke Robert, seized the castle of Tillières, which had been entrusted to the custody of Gilbert Crispin,<sup>286</sup> [who initially] resolute was swayed by the duke's pleas, and set fire to it, after which [he did] the same at Argentan.<sup>287</sup> A little later, Thurstan, named Goz son of the Dane Anfrid,<sup>288</sup> who was vicomte of the Hiémois, inspired by treacherous zeal, hired soldiers as mercenaries for the defence of the fortress of Falaise, but Rodulf of Gacé, leader of the army, demolished part of the walls, and then Thurstan abandoned the castle and fled. Richard, son of the same [Fol. 153r] Thurstan, loyally served the duke, reconciled his father [to him], and acquired many more possessions than his father had lost.

[§25] At that same time, Mauger, brother of Duke Robert, succeeded Robert, archbishop of Rouen.<sup>289</sup> For, Richard, son of Gunnor, after the death of his wife, Judith, took another,

---

<sup>283</sup> Les Préaux, Eure, cant. Pont-Audemer.

<sup>284</sup> Robert I, count of Meulan (1081–1118).

<sup>285</sup> Henry de Beaumont, earl of Warwick (1088–1119).

<sup>286</sup> Gilbert Crispin I, castellan of Tillières (from c.1035); cf. *GND*, 2: 101 n. 3.

<sup>287</sup> Argentan, Orne, chef-lieu de cant.

<sup>288</sup> Thurstan Goz, vicomte of Hiémois († after 1043).

<sup>289</sup> Mauger, archbishop of Rouen (1037–1054/55).

named Papia, from whom [were born] the aforesaid Mauger and William of Arques,<sup>290</sup> to whom Duke William, his nephew, granted the county of Talou, for which he would henceforth serve. This same William of Arques built the stronghold of Arques on top of the hill, and afterwards rebelled against Duke William. The duke ordered him to show his allegiance, which he refused to do. However, the duke erected a [siege] castle at the foot of the hill, and, in spite of King Henry's support [for William of Arques], the aforesaid William surrendered the said castle to the aforesaid Duke William.

[§26] At that same time, Cnut, king of England, died, and was succeeded by Harold,<sup>291</sup> his son born of a concubine. Hearing of Cnut's death, Edward, who was then living in Duke William's household, landed at Southampton with forty ships full of knights, and there met a multitude of Englishmen, and returned to Normandy with booty. In the meantime, his brother Alfred came to Dover and came up against Earl Godwin,<sup>292</sup> who welcomed Alfred as a friend. And after that same night he sent him with his hands bound to King Harold at London, who blinded him and had his knights beheaded. Shortly thereafter Harold died, and was succeeded by his brother, Harthacnut,<sup>293</sup> born of Emma mother of Edward, who had returned from Denmark. Soon after he had been established as king, he summoned his brother Edward from Normandy to come and live with him, [and] with Harthacnut's death, he left Edward as heir to the whole kingdom. [Edward] discharged Godwin of the shameful murder of his brother and ruled the realm of the English for almost twenty-three years.

---

<sup>290</sup> William, count of Arques († after 1054).

<sup>291</sup> Harold Harefoot, king of England (1035–40).

<sup>292</sup> Godwin, earl of Wessex (1020–53).

<sup>293</sup> Harthacnut, king of England (1040–42).

[§27] After which Duke William banished William named Welenc, count of Mortain,<sup>294</sup> and the duke gave the county of Mortain to his brother Robert.<sup>295</sup> Afterwards, William Busac, wanting to subjugate the duchy, was driven into exile by Duke William.

[§28] At this time, the duke joined to himself as wife the daughter of Baldwin [V] of Flanders, who was his kinswoman, but afterwards he obtained a dispensation from the pope, and on account of this they founded two churches at Caen. And afterwards, namely in the year 1054, Henry, anointed king of France, attacked Normandy, saying that the Normans had claimed this land through violence, but the duke withstood strongly.

[§29] Edward, king of England, subsequently died without offspring. This [Edward] had previously instituted Duke William as his heir, [and] had sent to him Harold,<sup>296</sup> who swore fealty to the same duke about the kingdom of England. The duke promised that he would give [Harold] his daughter, Adeliza, with half the kingdom of England, and he sent him back to England, retaining his brother, Wulfnoth,<sup>297</sup> as hostage. With the death of the aforesaid King Edward in the year of the Lord 1065, Harold immediately seized the kingdom against the oath he had sworn, as was mentioned, to the duke.

**[Fol. 153v]** [§30] At that same time, a comet appeared in those parts, and it portended, as many said, a change in some kingdom.

---

<sup>294</sup> William Welenc, count of Mortain (1026–after 1055). Mortain, Manche, cant. Le Mortainais.

<sup>295</sup> Robert, count of Mortain (after 1056–1090).

<sup>296</sup> Harold Godwinson, king of England (1066).

<sup>297</sup> Wulfnoth Godwinson (1040–94).

[§31] In that same year 1065, William, duke of Normandy, was rather frightened by Conan, count of Brittany.<sup>298</sup> He demanded that Normandy be returned to him or else he promised to make war. And William, thus safe again, hastily constructed a fleet of up to 3,000 ships, and brought them together in Ponthieu at Saint-Valery.<sup>299</sup> He gathered an immense army of Normans, Flemish, French and Bretons, and crossed the sea and landed at Pevensey, where [he built] a castle, and then [went] to Hastings [where] he built another. At that time, Harold was involved in a war against Tostig,<sup>300</sup> his brother, during which war he killed his brother and the king of Norway.<sup>301</sup> And immediately upon hearing the news of the arrival of the duke of the Normans, he gathered innumerable English forces for six days, against the advice of his mother and brother, Earl Gyrrh.<sup>302</sup> The duke therefore arranged his army and legions of warriors in three divisions, and without fear advanced against the dreadful enemy early in the morning of Saturday at the third hour, and battle was joined until nightfall. And there Harold [was] mortally wounded and slain during the first assault. The English, fleeing, were pursued by the Normans through the night, and 15,000 men perished there at [the hands of the Almighty] Judge. The following Sunday night the same Judge avenged the English. Therefore, in the year 1066, Duke William was elected king by everyone, both Normans and English, and was anointed with holy oil by the bishops of the realm and crowned with the royal diadem. The place in which that battle took place is called Battle to this day, in which King William built an abbey in honour of the Holy Trinity. And, returning to Normandy, he caused the church of St Mary at Jumièges to be dedicated, and entrusted the Norman duchy to

---

<sup>298</sup> Conan II, duke of Brittany (1040–66).

<sup>299</sup> Saint-Valery-sur-Somme, Somme, cant. Abbeville-2.

<sup>300</sup> Tostig Godwinson, earl of Northumbria (1055–65).

<sup>301</sup> Harald Hardrada, king of Norway (1046–66).

<sup>302</sup> Gyrrh Godwinson, earl of East Anglia (1057–66).

his son, Robert,<sup>303</sup> and returned to England, where he vanquished the very many persons who, at the beginning of Lent, had proposed killing all the king's faithful men.

---

<sup>303</sup> Robert Curthose, later duke of Normandy (1087–1106).



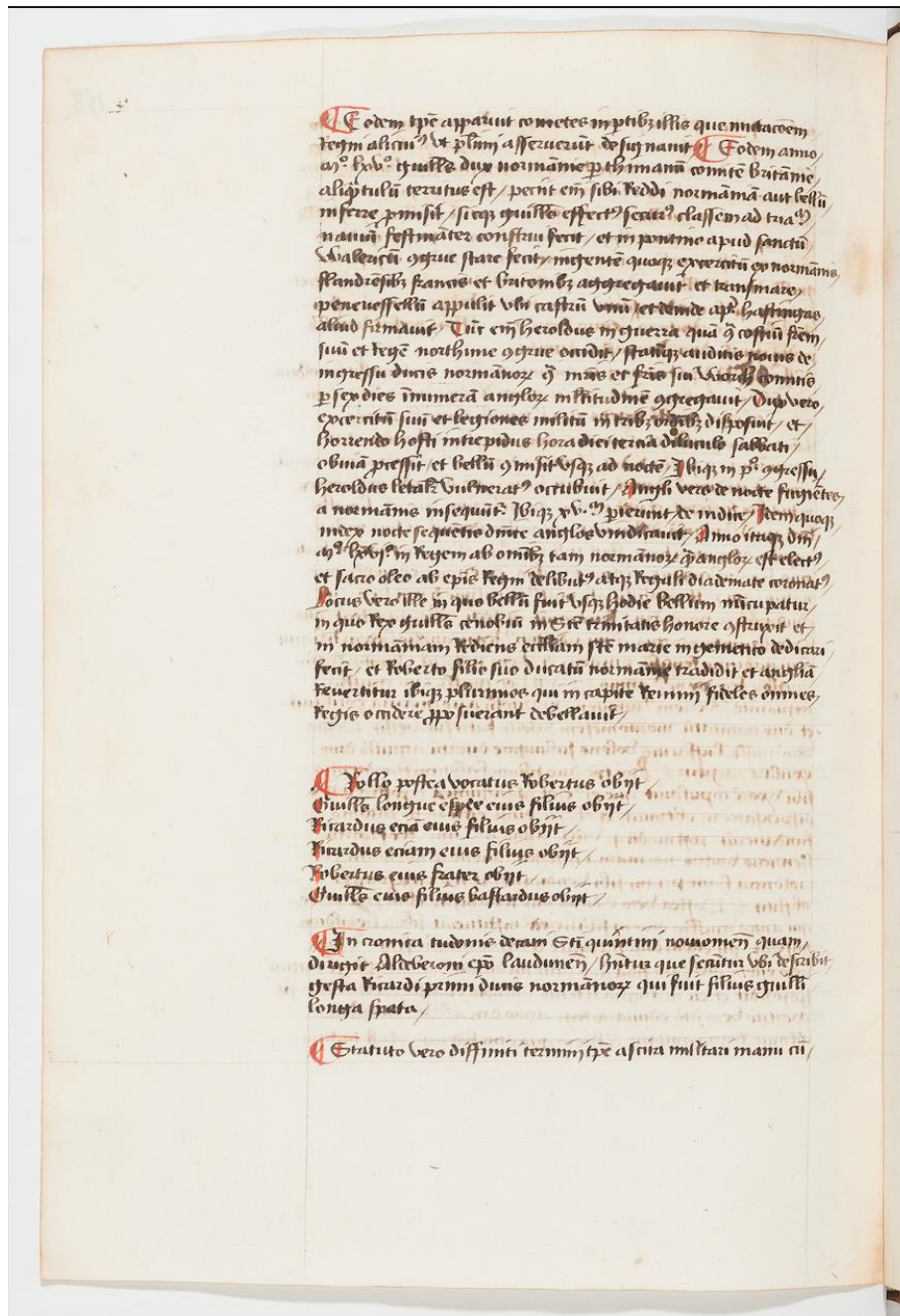

Fig. 2: End of the *Brevis cronica* in Paris, Bibliothèque de l'Arsenal, MS 1094, fol. 153v. ©

Gallica. Reproduced with permission of the BnF



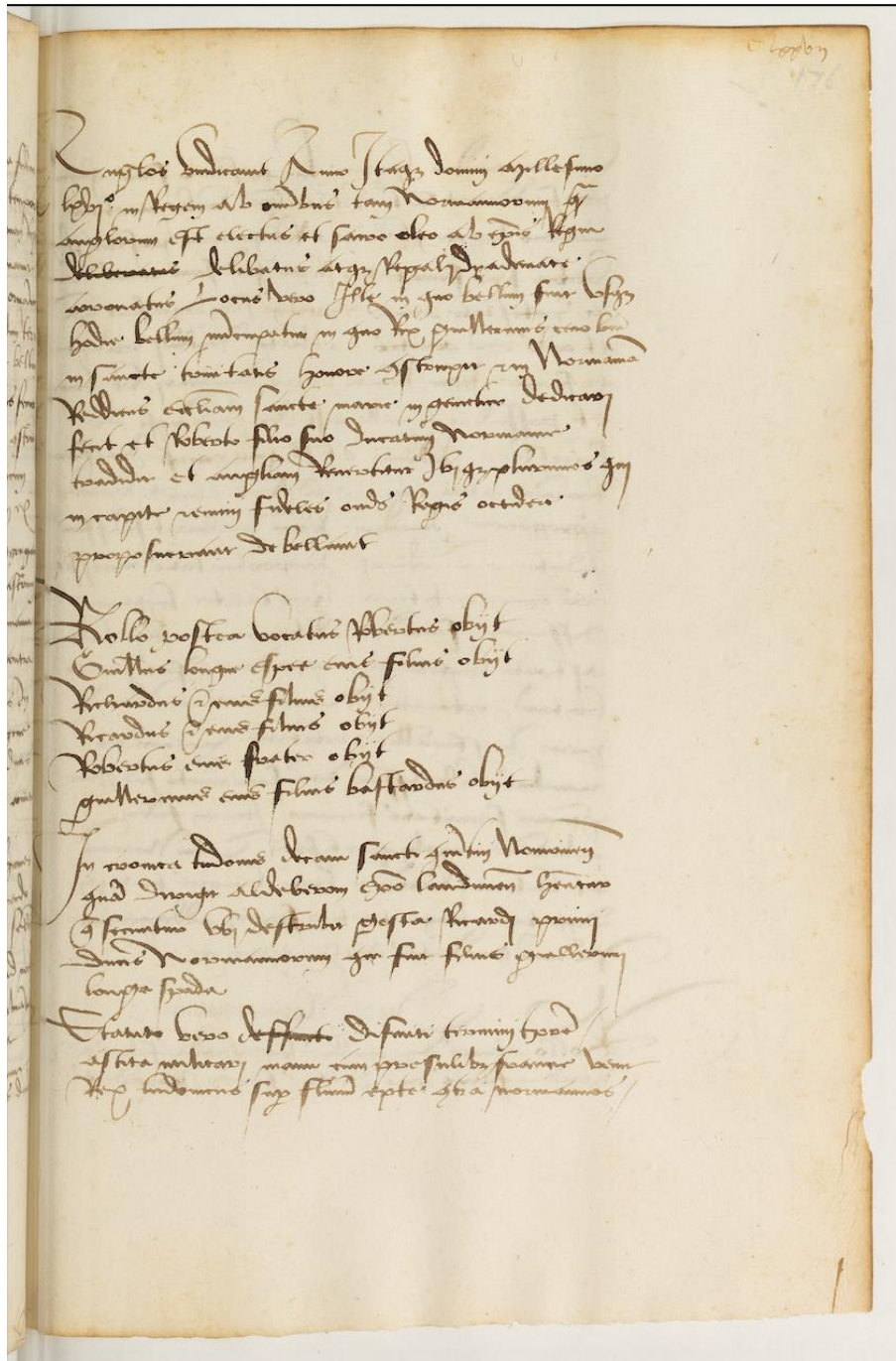

Fig. 4: End of the *Brevis cronica* in Paris, Bibliothèque nationale de France, MS Lat. 12882,

fol. 176r. © Gallica. Reproduced with permission of the BnF

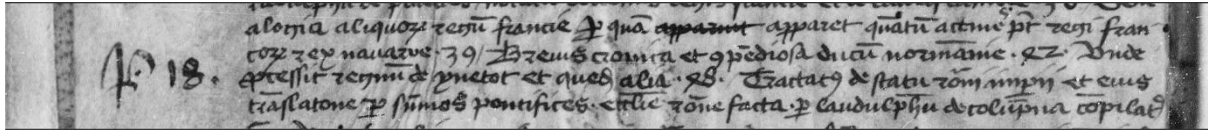

Fig. 5: Table of contents in Paris, Bibliothèque nationale de France, MS Lat. 14663, fol. iiv (detail). © Gallica. Reproduced with permission of the Bibliothèque nationale de France

\* The research for this article was generously supported by the Research Initiatives Fund of the Faculty of Arts, University of Bristol. We would like to express our thanks to Francesco Siri for kindly facilitating access to the manuscripts, as well as to Samu Niskanen for his invaluable assistance with some of the more difficult passages in the edition and translation. The article's preliminary findings were presented at a workshop held at Fordham University, NYC in May 2019, and we would like to thank the organisers and participants for their helpful comments, particularly Scott Bruce, Nicholas Paul and Paul Bertrand. Thanks are also due to the anonymous reviewers for their comments on earlier drafts. All remaining errors are, of course, entirely our own.

<sup>1</sup> Pierre Courroux, *L'écriture de l'histoire dans les chroniques françaises (XII<sup>e</sup>–XV<sup>e</sup> siècle)* (Paris, 2016), 452: "Les chroniqueurs médiévaux se servirent de leurs sources de la même manière que les Pères de l'Église reprenaient la tradition païenne: en les adaptant à leurs visées".

<sup>2</sup> The two most recent studies on Simon de Plumetot are Olivier Delsaux, "L'humaniste Simon de Plumetot et sa copie des poésies d'Eustache Deschamps: Une édition génétique au début du XV<sup>e</sup> siècle? (Partie I)," *Revue d'Histoire des Textes* 9 (2014): 273–349, and Annick Brabant, "Documenter le Grand Schisme d'Occident: Étude sur les recueils de deux intellectuels normands, Simon du Bosc et Simon de Plumetot," *Mélanges de l'École française de Rome — Moyen Âge* 123 (2011): 597–610, available online (without pagination), <<http://journals.openedition.org/mefrm/642>> [accessed 5 Dec 2019]. They expand the previous studies by Gilbert Ouy, "Simon de Plumetot (1371–1443) et sa bibliothèque," *Miscellanea Codicologica F. Masai Dicata*, ed. Pierre Cockshaw and Monique-Cécile Garand (Ghent, 1979), 2: 353–81; Gilbert Ouy, "Autographes d'auteurs français des XIV<sup>e</sup> et XV<sup>e</sup> siècles: Leur utilité pour l'histoire intellectuelle," *Studia zródloznawcze* 28 (1983): 69–103. See also Jenny Stratford, "The Illustration of the Songe du Vergier and some Fifteenth-Century Manuscripts," *Patrons, Authors and Workshops: Books and Book Production in Paris around 1400*, ed. Godfried Croenen and Peter F. Ainsworth (Louvain, 2006), 473–88, at 482–83; David. Luscombe and Betty Radice, ed./tr., *The Letter Collection of Peter Abelard and Heloise* (Oxford, 2013), xcvi–xcvii.

<sup>3</sup> Henry Martin, ed., *Catalogue des manuscrits de la Bibliothèque de l'Arsenal* (Paris, 1885–1896), 2: 273–75; also cf. Elisabeth M. C. van Houts, ed., *The Gesta Normannorum ducum*

by William of Jumièges, Orderic Vitalis, and Robert of Torigni (Oxford, 1992–95), 1: cxix (= F23) [hereafter *GND*]. The most recent and detailed published discussion of this manuscript is that by Matthias M. Tischler, *Einharts Vita Karoli: Studien zur Entstehung, Überlieferung und Rezeption* (Hannover, 2001), 1: 1094–1100 (= Pa 1) [hereafter *VK*]. For a more recent yet unpublished discussion, with a particular focus on Nithard and the *Annals* of Flodoard, see Stéphane Lecouteux, “Les Annales de Flodoard de Reims (919–966) dans la tradition historiographique du Moyen Âge: Travail de l’annaliste et de l’historien, perception et maîtrise du temps (VIII<sup>e</sup>–XII<sup>e</sup> siècles),” *Mémoire de Master 2* (Paris, École Pratique des Hautes Études, 2011), 81–86.

<sup>4</sup> Léopold V. Delisle, ed., *Inventaire des manuscrits de Saint-Germain-des-Prés conservés à la Bibliothèque impériale, sous les numéros 11504–14231 du fonds Latin* (Paris, 1868), 77; *GND*, 1: cxvii (= F19).

<sup>5</sup> Léopold V. Delisle, “Inventaire des manuscrits de Saint-Victor conservés à la Bibliothèque impériale, sous les numéros 14232–15175 du fonds Latin,” *Bibliothèque de l’école des chartes* 30 (1869): 1–79, at 36–37; *GND*, 1: cxvii–cxviii (= F20); *VK*, 2: 1065–82 (= Pa 21).

<sup>6</sup> See the bibliographical references listed in the online catalogue of the Bibliothèque nationale de France, <<https://archivesetmanuscrits.bnf.fr/ark:/12148/cc75414d>> [accessed 5 Dec 2019].

<sup>7</sup> For a full list of the manuscript’s contents and the sequence in which they were copied, see *VK*, 2: 1065–77.

<sup>8</sup> Chantal Grell, “History and Historians in France, from the Great Italian Wars to the Death of Louis XIV,” *The Oxford History of Historical Writing*, 3, 1400–1800, ed. José Rabasa, Masayuki Sato, Edoardo Tortarolo, and Daniel Woolf (Oxford, 2012), 384–405, at 384.

<sup>9</sup> Cf. the fifteenth-century contents list in A†, fol. iv.

<sup>10</sup> “De origine comitum Andegavensium” combines passages from Ralph’s *Abbreviationes chronicorum* and *Ymagines historiarum*; see *VK*, 2: 1065–66, n. 525. The text has been edited by Paul Marchegay and André Salmon, ed., *Chroniques d’Anjou* (Paris, 1871), 1: 319–47.

<sup>11</sup> *GND*, 1: cxvii–cxviii and cxxvi–cxxviii. See also Elisabeth M. C. van Houts, “The *Gesta Normannorum ducum*: A History Without an End,” *Anglo-Norman Studies* 3 (1980): 106–18.

<sup>12</sup> Léopold V. Delisle, ed., *Chronique de Robert de Torigni, abbé du Mont-Saint-Michel* (Rouen, 1872–73); Richard Howlett, ed., *Chronicles of the Reigns of Stephen, Henry II, and Richard I* 4, *The Chronicle of Robert of Torigni, Abbot of the Monastery of St. Michael-in-Peril-of-the-Sea* (London, 1889). The most recent edition/translation of Robert’s *Chronica* is now Thomas N. Bisson, ed., *The Chronography of Robert of Torigni* (Oxford, 2020). On the anonymous Anglo-Norman history and its possible sources, see Jean Laporte, ed., *Annales de l’Abbaye St. Pierre de Jumièges: Chronique universelle des origines au XIII<sup>e</sup> siècle* (Rouen, 1954), 20–21, 123–27; also cf. the discussion in *VK*, 2: 1073, n. 554. On the *Annals of Jumièges*, see Alison Alexander, “Annalistic Writing in Normandy, c.1050–c.1225,” unpublished doctoral thesis (University of Cambridge, 2011), 84–103.

<sup>13</sup> See *VK*, 2: 1065–77. Nine of these ten booklets (“Parts B–J”) were bound together in their current order by the late 1420s, whereas the booklet that now constitutes the opening of the book (fol. 1r–12v; “Part A”) was added later in the fifteenth century (*ibid.*, 1066–67). As

Tischler explains, the manuscript originally opened with what is now fol. 13r–v, as is evidenced by an institutional ownership mark found on the recto of this folio that was likely inserted when the book passed into the possession of Saint-Victor, following the death of its maker and previous owner (Simon de Plumetot) during the early to mid-1440s (*ibid.*, 1066).

<sup>14</sup> *VK*, 2: 1071–74. Tischler's identification of Rouen as the most likely place of origin for the composition of “Part D” is, on the one hand, based on his observation that all but one of the texts included in this particular section of the manuscript (as well as the first two texts in “Part E”) can also be found in (a) Rouennaise exemplar(s) (*ibid.*, 1072). On the other hand, Tischler's attribution of “Part D” and “Part E” to Rouen and Paris, respectively, is supported further by the fact that they are written on sheets of paper which bear watermarks specific to these two cities (see *ibid.*, 1072 n. 552 and 1075 n. 560).

<sup>15</sup> In its original form, the volume seems to have opened with the abbreviated chronicle of the kings of France (now fols. 14r–20r); cf. *VK*, 2: 1066–67.

<sup>16</sup> These other lists/catalogues include the names of the Old Testament rulers (fol. 21r–v); the Roman emperors (fols. 21v–22r); the Roman popes (fols. 22r–23r); the Frankish/French kings (fol. 23r); the archbishops of Sens (fol. 23r–v) and Auxerre (fols. 23v–24r). In addition, there is a genealogy (or “family tree”) of the Frankish/French kings (fols. 39–41v), as well as a list of the French kings (fol. 276v).

<sup>17</sup> *VK*, 2: 1070–71. It is not possible, at this stage, to identify the hand that wrote this list of contents in Paris, Bibliothèque nationale de France, MS lat. 14663, fol. iiv as belonging to Simon de Plumetot. Likewise, due to an apparent absence of watermarks and other locally-specific features on these pages it is not possible to pinpoint the composition of this section to either Rouen or Paris in the same way as is possible with regard to, for example, “Part D” and “Part E” (see above, n. 14).

<sup>18</sup> It cannot have happened before the sixteenth century, when the text was copied from **A**† (see below) into **C**. Based on an eighteenth-century catalogue entry, Tischler suspects that the six removed folia might have resurfaced temporarily as part of a different manuscript (Paris, Bibliothèque nationale de France, MS lat. 6264) before they were lost again, but this must remain speculation; *VK*, 2: 1134–36.

<sup>19</sup> *Inventaire des manuscrits de Saint-Germain-des-Prés*, 77 refers to **C** as “Guillaume de Jumièges et divers morceaux historiques tirés du recueil formant le ms. Latin 14663”. Liesbeth van Houts has confirmed this relationship in her edition of William of Jumièges' *GND*, which identifies both **B** (van Houts' F19) and **C** (F23) as “a copy of F20 [= **A**†]”; *GND*, 1: cxvii and cxix. Most recently, Tischler has corroborated the same filiation for the manuscripts' two copies of Einhard's *Vita Karoli*; see the *stemma codicum* provided in *VK*, 2: 1101. Tischler describes **B** as “an almost complete copy” (“eine nahezu vollständige Kopie”) of **A**† (*ibid.*, 1094).

<sup>20</sup> *VK*, 2: 1070–71.

<sup>21</sup> **A**† = avg. 48–53 letters/line, 36 lines/page; **B** = 50–55 letters/line, 42 lines/page; **C** = avg. 35–40 letters/line, 28 lines/page. Note that **B** uses significantly more abbreviations than **C**, which likely accounts for the slight difference in the numerical sums. The calculation for **A**† is based primarily on the “History of Yvetot” (fol. 48r), given that the final folio of Lescot's

genealogy (fol. 41r–v) written by “Scribe B” only contains free-hand genealogical tables that do not abide by the *mise-en-page*; the preceding sections (fols. 39r–40v) do conform to the page layout, but they are written by a different hand (Tischler’s “Scribe A”), though both hands might in fact belong to the same scribe working several years apart (see below); also cf. *VK*, 2: 1070. Dudo’s *Historia Normannorum* has been edited by Jules Lair, ed., *De moribus et actis primorum Normanniae ducum* (Caen, 1865) [hereafter *HN*]; on the text’s manuscript tradition, see Benjamin Pohl, *Dudo of Saint-Quentin’s Historia Normannorum: Tradition, Innovation and Memory* (York, 2015), 18–109; Benjamin Pohl, “Pictures, Poems and Purpose. New Perspectives on the Manuscripts of Dudo of St. Quentin’s *Historia Normannorum*,” *Scriptorium* 67 (2013): 229–58.

<sup>22</sup> Cf. *VK*, 2: 1095–98. The fourteen texts in **A**†, fols. 181r–304r (“Parts F–J”), by contrast, are not copied in **B**. The only two texts from “Parts A–E” that are not duplicated in **B** are the *Comites Tolosani* (fols. 175v–179v) and the account of the truce between Louis IX and Henry III (fols. 179v–180v).

<sup>23</sup> While **A**†, fols. 1r–13v (“Part A”) and fol. 37r–v both represent later fifteenth-century additions (see above), there is no evidence to suggest that the order of texts found today on fols. 14r–180v (“Parts B–E”) is different from that in the book’s original early fifteenth-century binding. This is confirmed further by the book’s original pagination, which perfectly matches that in the fifteenth-century list of contents (fol. iiv). Similarly, a detailed list of contents for **B** that survives in a catalogue made during the 1480s confirms that this manuscript, too, preserves its original form despite having been rebound in the seventeenth century. On both manuscripts and their bindings, cf. the relevant discussions in *VK*, 2: 1066–67, 1078–79, and 1098–99.

<sup>24</sup> *GND*, 1: cxvii; *VK*, 2: 1091 and 1136.

<sup>25</sup> *GND*, 1: cxvii and cxix.

<sup>26</sup> **A**†, fols. 21r–24v; copied (and in some cases continued) in **B**, fols. 127r–131v, fol. 149r–v, and fol. 154r–v, and in **C**, fols. 177v–178r.

<sup>27</sup> Similar catalogues were compiled by historiographers of earlier centuries, including the Anglo-Norman period. For example, Robert of Torigni produced long lists of Norman, French and English archbishops, bishops and abbots to assist with the composition of his *Chronica* (and possibly his redaction of William of Jumièges’ *GND*), copies of which survive on the flyleaves of Paris, Bibliothèque nationale de France, MS lat. 6042, fols. 1v–2v and 121v–122v, as well as in Cambridge, University Library, MS Gg. 2.21; see Benjamin Pohl, “Robert of Torigni and Le Bec: The Man and the Myth,” *A Companion to the Abbey of Le Bec in the Central Middle Ages (11<sup>th</sup>–13<sup>th</sup> Centuries)*, ed. Benjamin Pohl and Laura L. Gathagan (Leiden, 2017), 94–124, at 120–21.

<sup>28</sup> There is, of course, the theoretical possibility that the *Brevis cronica* was written at an earlier point — the *terminus post quem* being William the Conqueror’s victory at the Battle of Hastings in 1066 and the subsequent bestowal of the Norman duchy upon his eldest son, Robert Curthose (**B**, fol. 153v) —, and that the maker of **A**† merely copied (rather than composed) the text, just as he did the works of other writers from the Anglo-Norman period. This seems unlikely, however, given the “draft-like” language of the text that bears little to

no resemblance to the Latin used by historians of earlier centuries. In the absence of any concrete evidence to the contrary, the *Brevis cronica* once found in A† will therefore be treated as an “original” composition.

<sup>29</sup> B was produced on behalf of (but not by) Jean Budé (1430–1502), who employed a range of copyists in his personal service; see Monique-Cécile Garand, “Les copistes de Jean Budé (1430–1502),” *Bulletin d’information de l’Institut de Recherche et d’Histoire des Textes* 15 (1969): 293–332; also cf. *GND*, 1: cxix; *VK*, 2: 1098. The owners of C have been well established from the late sixteenth/early seventeenth century onwards, but precious little is known for the period prior to that; see *GND*, 1: cxvii.

<sup>30</sup> For discussion, with reference to an image of the colophon in A†, fol. 13r, which reads, in part, “*Ce livre cy ont escript maistre Symon de Plumetot advocat au Parlement*”, see *VK*, 2: 1078 n. 580.

<sup>31</sup> On what follows, see Delsaux, “L’humaniste Simon”, 275–85; Ouy, “Simon de Plumetot”, 359–64.

<sup>32</sup> On Simon’s activities in Rouen, see *VK*, 2: 1078–79; also cf. Ouy, “Simon de Plumetot”, 363–64.

<sup>33</sup> The structural differences between the *GND*’s different redactions are visualised helpfully in the summary table provided by van Houts, “The Gesta Normannorum ducum”, 116 (= “Appendix I”). Also cf. *GND*, 1: cxxi–cxxxviii.

<sup>34</sup> Van Houts, “The Gesta Normannorum ducum”, 108–10; *GND*, 1: lxi and lxxvii–xc. Also cf. Pohl, *Dudo of Saint-Quentin’s Historia Normannorum*, 225–40. Examples indicating that Simon used Dudo’s *HN* directly, rather than through its second-hand insertion in the *GND*, include: the name given to Bernard, who in the *Brevis cronica* appears as Bernard of Rouen (“Bernardo scilicet Rothomagen(sis)”; B, fol. 151v), rather than Bernard the Dane (“Bernardus Danus/Dacigenus”; *GND*, 1: 100 and 106); the order of the monastic churches founded by Duke Richard I, which in accordance with the *HN* are listed in the *Brevis cronica* as Rouen — Mont St Michel — Fécamp (“[ecclesie] beate Marie Rothomagi, sancti Michaelis in Monte, et sancte Trinitatis in Fisca(n)no”; B, fol. 151v; *HN*, 290), rather than Fécamp — Rouen — Mont Saint-Michel (*GND*, 1: 130–33); the passage telling of William Longsword’s acceptance as duke amongst the people of the Franks, Burgundians, Flemish, English, Danes and Irish (“...sicque exaltatus est quod Franci, Burgundi, Flandrenses, Angli et Dacigene, et Isberne(n)ses ei parebant”; B, beginning of fol. 151r), which is provided by Dudo (*HN*, 192), but not in the *GND*.

<sup>35</sup> B, fol. 150v: “et nichilominus prefatus [...] exiit in Christo”; *GND*, 1: 68–69. The first part of this re-insertion of the *HN* into the *GND* belongs to Robert of Torigni (“redaction F”) and the second part to Orderic Vitalis (“redaction E”), which was subsequently adopted by Robert. According to van Houts, it was Robert who first combined Dudo’s original account with Orderic’s additions concerning the Battle of Soissons etc., which is precisely what can be seen in the *Brevis cronica*; *GND*, 1: lxxx.ii.

<sup>36</sup> Cf. *HN*, 183–86, 192–93; *GND*, 1: 76–79.

<sup>37</sup> Today, there are almost fifty surviving copies of the *GND* in its various redactions; see van Houts, “The Gesta Normannorum ducum”, 116; *GND*, 1: xcv–cxxi. By contrast, there are

only fourteen known manuscripts of Dudo's *HN*; see Pohl, *Dudo of Saint-Quentin's Historia Normannorum*, 262–63.

<sup>38</sup> Ouy, “Simon de Plumetot”, 363; Delsaux, “L’humaniste Simon”, 285–96; *VK*, 2: 1066. Also cf. Franck Collard, “La bibliothèque de Saint-Victor au service des rénovateurs de l’histoire de France vers 1500? Nicole Gilles, Robert Gaguin et Paul Émile face aux ressources victorines,” *Cahiers de recherches médiévales et humanistes* 17 (2009): 227–40.

<sup>39</sup> For St Bonaventure’s scheme of authorship, see Alastair Minnis, *Medieval Theory of Authorship: Scholastic Literary Attitudes in the Later Middle Ages*, 2nd ed. (Philadelphia, 1988), 94.

<sup>40</sup> Ouy, “Simon de Plumetot”, 373–81. For minor corrections to this, see Gilbert Ouy, ed., *Les manuscrits de l’abbaye de Saint-Victor: Catalogue établi sur la base du répertoire de Claude de Grandrue (1514)* (Turnhout, 1999), 1: 15–19.

<sup>41</sup> That Simon appears to have taken extracts from the *GND* and adapted them for use in the *Brevis cronica* before copying William’s chronicle *in extenso* should come as no surprise. After all, such a pattern of production not only ties in with what we know about Simon’s working practices (on which see below), but it also no doubt reflects the practicalities of interacting with a large text, the pragmatic dynamics of which are as familiar to modern students of history as they were to their medieval counterparts, whereby notes are first taken, often in “draft-like” form, before more extensive (or even verbatim) copies are made when both time and resources allow.

<sup>42</sup> Collard, “La bibliothèque de Saint-Victor”, 232.

<sup>43</sup> Ouy, “Simon de Plumetot”, 369.

<sup>44</sup> On the autographs collected by Simon, see Ouy, “Simon de Plumetot”, *passim*; Ouy, “Autographes d’auteurs français”, 69; Olivier Delsaux, *Manuscrits et pratiques autographes chez les écrivains français de la fin du Moyen Âge: L’exemple de Christine de Pizan* (Geneva, 2013), 174–78; Danièle Calvot and Gilbert Ouy, *L’œuvre de Gerson à Saint-Victor de Paris: Catalogue des manuscrits* (Paris, 1990), 21–23.

<sup>45</sup> Ouy, “Simon de Plumetot”, 371–72. Not everyone is in agreement, however, that Simon was the author of several poems as argued by Gilbert Ouy; for an alternative view, see Olivier Delsaux, “L’humaniste Simon de Plumetot et sa copie des poésies d’Eustache Deschamps: Une édition génétique au début du XV<sup>e</sup> siècle? (Partie II),” *Revue d’Histoire des Textes* 10 (2015): 141–95, at 164.

<sup>46</sup> By contrast, a comparison (both stylistically and structurally) between the *Brevis cronica* and Simon’s other known authorial works yields little useful information due to the fact that the latter are predominantly finished versions, whereas the *Brevis cronica* shows clear signs of being either a draft or, at the very least, a work-in-progress. An interesting avenue for future research would be a detailed comparison between the *Brevis cronica* and the fourteenth-century *Grande Chronique de Normandie*, on which see particularly Gilette Labory, “Les manuscrits de la Grande Chronique de Normandie du XIV<sup>e</sup> et du XV<sup>e</sup> siècle,” *Revue d’histoire des textes* 27 (1997): 191–222.

<sup>47</sup> A†, fols. 1r–10r (Anjou), 251r–273v (Guillaume de Nagis). There are other abbreviated chronicles of the kings of France on fols. 14r–20r and 181r–192v.

<sup>48</sup> Isabelle Guyot-Bachy, “La Chronique abrégée des rois de France et les Grandes chroniques de France: Concurrence ou complémentarité dans la construction d’une culture historique en France à la fin du Moyen Âge,” *The Medieval Chronicle* 8 (2013): 205–32, at 215.

<sup>49</sup> Isabelle Guyot-Bachy, “La Chronique abrégée des rois de France de Guillaume de Nangis: Trois étapes de l’histoire d’un texte,” *Religion et mentalités au Moyen Age. Mélanges en l’honneur d’Hervé Martin*, ed. Daniel Pichot, Amaury Chauou, and Lionel Rousselot (Rennes, 2003), 39–46, at 39.

<sup>50</sup> Guillaume’s abridged chronicle is best known by its vernacular text, but this is based upon an original Latin version that today is found in Paris, Bibliothèque nationale de France, MS lat. 6184, fols. 1r–15v.

<sup>51</sup> Sanford Zale, “Bastards or Kings or Both? Louis III and Carloman in Late-Medieval French Historiography,” *Comitatus* 29 (1998): 95–112.

<sup>52</sup> Guyot-Bachy, “La Chronique abrégée”, 215.

<sup>53</sup> Ouy, “Simon de Plumetot”, 369–71; Brabant, “Documenter le Grand Schisme”, n. p. Also cf. Gilbert Fournier, “Ouvrir la bibliothèque. Lecteurs étrangers et lectures étrangères au collège de Sorbonne au XV<sup>e</sup> siècle”, *Les manuscrits médiévaux témoins de lectures*, ed. Catherine Croizy-Naquet, Laurence Harf-Lancner, and Michelle Szkilnik (Paris, 2015), 17–45, at 31–35.

<sup>54</sup> For discussion, see Léopold V. Delisle, “Notice sur vingt manuscrits du Vatican,” *Bibliothèque de l’École des chartes* 37 (1876): 471–527, at 502 n. 1.

<sup>55</sup> Ouy, “Simon de Plumetot”, 371–72; Brabant, “Documenter le Grand Schisme”, n. p.

<sup>56</sup> Gilbert Ouy lists MS BBB.12 among those manuscripts “lui [Simon] ayant probablement appartenu”; Ouy, “Simon de Plumetot”, 379. See also Labory, “Les manuscrits de la Grande Chronique”, 200 for some important qualifications.

<sup>57</sup> Paris, Bibliothèque nationale de France, MS lat. 14767, fol. 180v.

<sup>58</sup> Laporte, *Annales de Jumièges*, 21 argues that this reworking of the annals could have been accomplished before 1220, meaning Simon would have simply copied an existing text. However, Laporte also notes the preponderance of entries concerning Anglo-French relations, a subject close to Simon’s heart, the absence of events relating to Jumièges itself and the fact that the text is “mauvais, abrégé avec négligence, et confus par endroits”, a description that could just as easily be applied to the *Brevis cronica*. As such, while it is likely Simon simply copied an existing text, it is not impossible that he “authored” these notes in the same manner as the *Brevis cronica*.

<sup>59</sup> “M<sup>o</sup>CCXXXIII<sup>o</sup> [*sic*]. Obiit inclitus rex Francie Ph(illip)us apud Medunta(m) et fuit portatus ad S(anc)tum Dionisiu(m), cui successit Ludovicus filius ejus et Blanchia ejus uxor filia regis Yspanie, et pariter coronati Remis die transmirationis Domini”; A†, fol. 174v.

<sup>60</sup> Gilbert Ouy, “Discovering Gerson the Humanist. Fifty Years of Serendipity,” in *A Companion to Jean Gerson*, ed. Brian P. McGuire (Leiden, 2006), 79–132, at 97.

<sup>61</sup> Leiden, Universiteitsbibliotheek, MS Vossius lat. F. 77, which is accorded the siglum F6 in van Houts’s critical edition of the *GND*. According to van Houts, A† (her F20) is one of five copies of redaction F, all of which are distinguished by the fact that at the end of book viii.42 there is a fragment of Robert of Torigni’s *Chronica* for 1137 (*GND*, 1:cxii–cxiii, cxvii, and

---

cxix). In **A**†, this fragment appears at the top of fol. 130v, and a later user of the manuscript, who was obviously comparing the text with Duchesne's edition (mentioned at the beginning in the margin of fol. 68r), has written "Hæc brævis additio non est edita". The other F redaction manuscripts that include this fragment are F19 (= our **C**); F23 (= our **B**); F8, which is an English manuscript (now in the Parker Library of Corpus Christi College, Cambridge); and F6 (now at Leiden). Since Simon is unlikely to have consulted the manuscript now at the Parker, it would seem that he copied the *GND* from the codex now at Leiden.

<sup>62</sup> Brabant, "Documenter le Grand Schisme", n. p.

<sup>63</sup> This is van Houts's F3 (*GND*, 1: cx). On this manuscript and its codicology, see Pohl, *Dudo of Saint-Quentin's Historia Normannorum*, 32–33; Pohl, "Pictures, Poems and Purpose", 244–57; Benjamin Pohl, "The Illustrated Archetype of the *Historia Normannorum*: Did Dudo of St. Quentin Write a 'Chronicon Pictum'?" *Anglo-Norman Studies* 37 (2015): 225–55.

<sup>64</sup> Brabant, "Documenter le Grand Schisme", n. p.

<sup>65</sup> *GND*, 1: xci. See also van Houts, "The Gesta Normannorum ducum", *passim*.