

# A variant in the sonic hedgehog regulatory sequence (ZRS) is associated with triphalangeal thumb and deregulates expression in the developing limb

Dominic Furniss<sup>1,2</sup>, Laura A. Lettice<sup>3</sup>, Indira B. Taylor<sup>1</sup>, Paul S. Critchley<sup>2</sup>, Henk Giele<sup>2</sup>, Robert E. Hill<sup>3</sup> and Andrew O.M. Wilkie<sup>1,\*</sup>

<sup>1</sup>Weatherall Institute of Molecular Medicine, University of Oxford, John Radcliffe Hospital, Oxford OX3 9DS, UK, <sup>2</sup>Department of Plastic and Reconstructive Surgery, Oxford Radcliffe Hospitals NHS Trust, Oxford OX3 9DU, UK and <sup>3</sup>MRC Human Genetics Unit, Western General Hospital, Edinburgh EH4 2XU, UK

Received March 9, 2008; Revised and Accepted April 30, 2008

**A locus for triphalangeal thumb, variably associated with pre-axial polydactyly, was previously identified in the zone of polarizing activity regulatory sequence (ZRS), a long range limb-specific enhancer of the Sonic Hedgehog (*SHH*) gene at human chromosome 7q36.3. Here, we demonstrate that a 295T>C variant in the human *ZRS*, previously thought to represent a neutral polymorphism, acts as a dominant allele with reduced penetrance. We found this variant in three independently ascertained probands from southern England with triphalangeal thumb, demonstrated significant linkage of the phenotype to the variant (LOD = 4.1), and identified a shared microsatellite haplotype around the *ZRS*, suggesting that the probands share a common ancestor. An individual homozygous for the 295C allele presented with isolated bilateral triphalangeal thumb resembling the heterozygous phenotype, suggesting that the variant is largely dominant to the wild-type allele. As a functional test of the pathogenicity of the 295C allele, we utilized a mutated *ZRS* construct to demonstrate that it can drive ectopic anterior expression of a reporter gene in the developing mouse forelimb. We conclude that the 295T>C variant is in fact pathogenic and, in southern England, appears to be the most common cause of triphalangeal thumb. Depending on the dispersal of the founding mutation, it may play a wider role in the aetiology of this disorder.**

## INTRODUCTION

Triphalangeal thumb is characterized by the presence of three phalanges within the thumb. The extra middle phalanx may be fully formed, trapezoidal in shape, or a small triangular 'delta' phalanx. In addition the thumb may be normally opposable, or non-opposable and in the plane of the fingers, and the first web space may be tight. These abnormalities often lead to progressive thumb deformity with functional limitation requiring surgical intervention (1). A frequently associated feature is pre-axial polydactyly; in combination, this clinical entity is described as pre-axial polydactyly type II [PPD2, MIM 174500].

Pre-axial polydactyly has been shown in several mouse models to be caused by perturbation of the normal antero-posterior axis of the developing limb (2). The signalling molecule Sonic Hedgehog (*Shh*) is normally expressed in a spatially and temporally restricted fashion in the posterior part of the developing limb bud, termed the zone of polarizing activity (ZPA). This restriction, combined with the effects of other molecules such as the processed repressor form (Gli3R) of Gli3 (GLI-Kruppel family member 3), leads to patterning of the developing autopod (3,4). Ectopic mis-expression of *Shh* in the anterior part of the limb bud in mice results in a secondary ZPA, leading to disturbance of the antero-posterior axis, and

\*To whom correspondence should be addressed. Tel: +44 1865222619; Fax: +44 1865222500; Email: awilkie@hammer.imm.ox.ac.uk

© 2008 The Author(s).

This is an Open Access article distributed under the terms of the Creative Commons Attribution Non-Commercial License (<http://creativecommons.org/licenses/by-nc/2.0/uk/>) which permits unrestricted non-commercial use, distribution, and reproduction in any medium, provided the original work is properly cited.

the anterior formation of polydactylous digits or a more 'finger-like' triphalangeal thumb (2).

The initial evidence that mutations affecting the regulation of the human *SHH* gene might cause limb malformation came from the study of the transgenic mouse mutant *Sasquatch* (*Ssq*). The *Ssq* mouse has pre-axial polydactyly and displays ectopic *Shh* expression at the anterior margin of the developing limb bud (5). The transgene insertion responsible for the phenotype was shown to be linked to *Shh*, but resided in intron 5 of a neighbouring gene, *Lmbr1* (limb-region homolog 1), located ~0.8 Mb away (6). To demonstrate that the phenotype was caused by disruption of a *Shh* regulator, rather than an effect on *Lmbr1*, a genetic *cis-trans* test was designed which showed that the *Ssq* mutation acted in *cis* to affect directly expression of the *Shh* allele (6).

In mice, transgenic analysis using a construct containing ~1.7 kb of murine sequence from *Lmbr1* intron 5 [linked to the *Hbb* (haemoglobin, beta) promoter, *LacZ* reporter and SV40 polyA signal], showed expression of  $\beta$ -galactosidase in the posterior margin of the developing limb bud in a spatio-temporal manner analogous to normal *Shh* expression (7). Multi-species comparison of this 'ZPA regulatory sequence' (ZRS) utilizing mouse, human, chick and *fugu* sequences demonstrated a highly conserved ~800 bp region within it (7); here we refer to these murine and human DNA sequences as *Zrs* and *ZRS*, respectively. The ZRS is highly conserved among cartilaginous and bony fishes and in the tetrapod lineage (8), but is absent from limbless reptiles and amphibians (9). Furthermore, homozygous deletion of the *Zrs* in the mouse (10) leads to loss of *Shh* expression in the limb associated with a limb truncation phenotype similar to that seen in the *Shh* knockout mouse (11). Interestingly, the severe midline central nervous system and craniofacial defects present in *Shh* knockout mice and leading to embryonic lethality (11) were not seen in the *Zrs* knockout mice, which were viable and survived until at least 3 months after birth (10). Taken together, these data demonstrate that the *Zrs* is an important limb-specific regulator of *Shh* expression.

Further evidence for the importance of the ZRS in regulating limb development has been obtained from the identification of point mutations in mice, cats and humans. In mice and cats, six different single nucleotide substitutions in the *Zrs* (three in each species) are associated with pre-axial polydactyly (7,12,13), and in humans seven point mutations and one duplication of the equivalent ZRS have been described in association with PPD2 (Fig. 1A) (7,14–16). In one of the latter reports, four additional polymorphisms in the ZRS, with frequencies of 10–30% in both Dutch controls and families, were thought to be neutral variants (7). Here we provide genetic and functional evidence that one of these, 295T>C, is in fact a dominant mutation with reduced penetrance that is a common cause of triphalangeal thumb in southern England.

## RESULTS

### Screening for ZRS mutations in congenital limb malformation

We recruited a cohort of 187 patients with a congenital limb malformation requiring reconstructive surgery. Of these, 5

had triphalangeal thumb (2 unilateral, 3 bilateral; one unilateral and one bilateral case were associated with unilateral pre-axial polydactyly) and 34 had pre-axial polydactyly (24 unilateral, including the two patients with triphalangeal thumb, and 10 bilateral). We previously identified a *SALL1* mutation in the patient with unilateral triphalangeal thumb and pre-axial polydactyly (17). Two patients in the cohort (neither of whom had either pre-axial polydactyly or triphalangeal thumb) had previously undescribed heterozygous ZRS variants (318T>A and 775G>C) that were considered unlikely to be pathogenic (see Materials and Methods). However, three additional patients (OX1925, OX3159 and OX3601), all of whom had bilateral triphalangeal thumb, were heterozygous for an identical 295T>C variant detected on denaturing high performance liquid chromatography (dHPLC) screening and DNA sequencing (Fig. 1A and B), and are the subject of this report.

Patient OX1925 presented as a 7-week-old female with isolated bilateral triphalangeal thumbs (Fig. 2A). There was no family history of congenital malformation, although the patient's mother was adopted and had no knowledge of her birth family (Fig. 3A). Patient OX3159 presented as a male infant with bilateral triphalangeal thumb and right hand pre-axial polydactyly (Fig. 2B). There was an extensive family history of similar malformations (Fig. 3B). Patient OX3601 presented as a 2-year-old female with isolated bilateral triphalangeal thumb. There was a family history of similar malformations (Fig. 3C). None of the affected individuals in any of the three families had additional malformations, including foot malformations. In particular, the mother of patient OX3601 was affected with bilateral triphalangeal thumb, and had no additional phenotypic features.

### Linkage and haplotype analysis

To assess the pathogenic significance of the 295C variant, we genotyped additional family members and healthy controls using a primer-mismatch generated *AlwNI* restriction digest. DNA was available from 15 relatives of patient OX3159, including 7 affected by triphalangeal thumb and/or pre-axial polydactyly, 4 clinically unaffected obligate carriers and 4 unaffected individuals at 50% prior risk. DNA was also available from the affected mother and aunt of patient OX3601. The 295C allele was present in heterozygous state in all affected individuals except the mother of OX3601, in whom it was homozygous (Figs. 1B and C, 3B and C). In addition, the 295TC genotype was found in the four unaffected obligate carriers and one unaffected individual at 50% prior risk (Fig. 3B). The 295C allele was absent in 762 normal chromosomes originating from ethnically matched north European Caucasian populations. The difference in occurrence of the 295C allele in probands with triphalangeal thumb (3/5), compared with controls (0/381), was highly significant ( $P = 1.05 \times 10^{-6}$ , Fisher's exact test).

Before undertaking linkage analysis to test the significance of the association in the family of OX3159, we estimated the penetrance of the 295C allele by comparing the observed number of affected offspring born to known carriers (=9) with that expected if penetrance was complete ( $38/2 = 19$ ), yielding a value of 0.47. However, this figure may be an overestimate as it does not take into account any occult carriers who had only unaffected offspring. As a more direct estimate

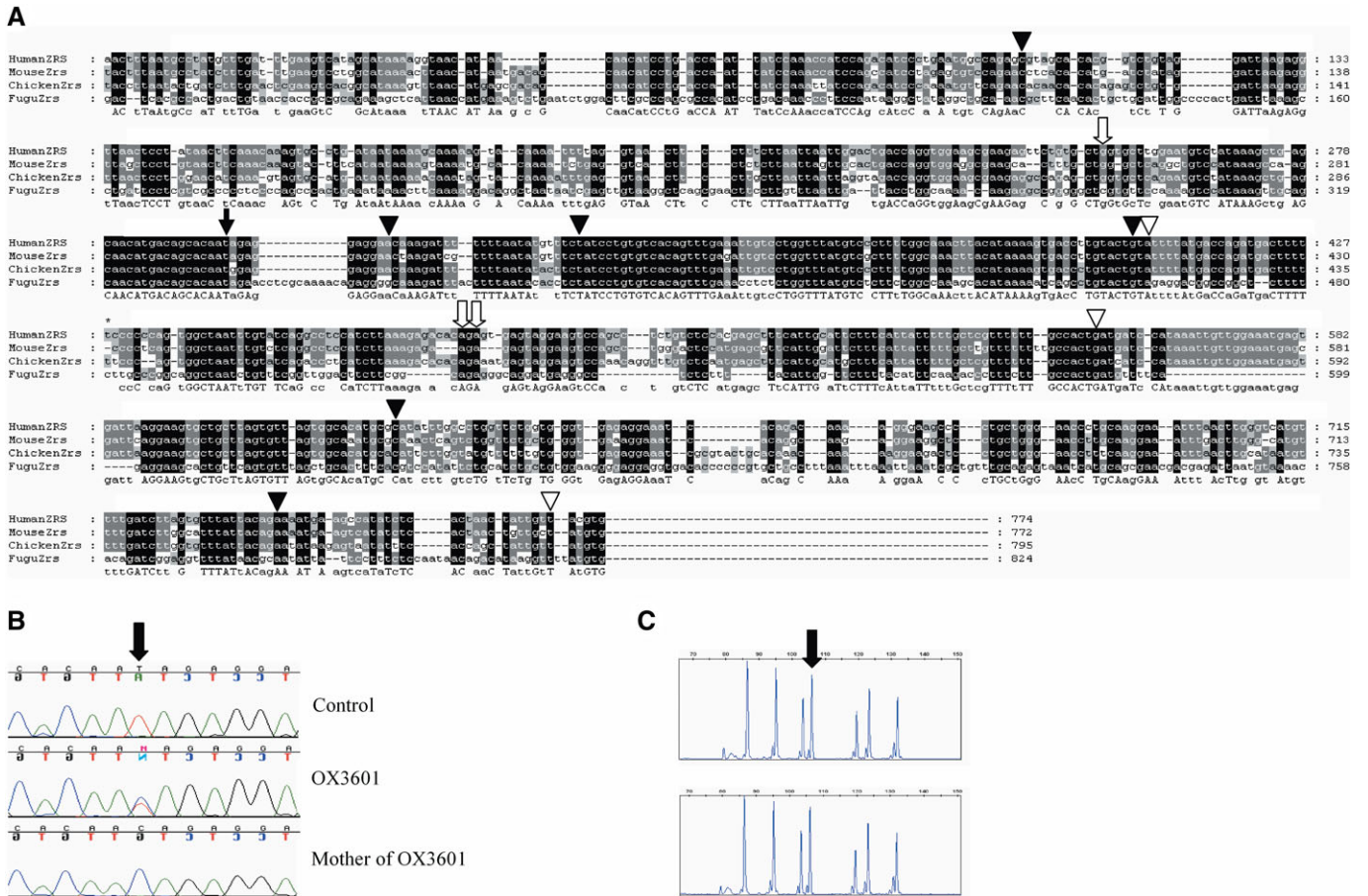

**Figure 1.** The highly conserved part of the ZRS sequence and identification of the 295T>C variant. (A) Alignment of human, mouse, chick and fugu ZRS produced using Genedoc v2.6.003 (<http://www.nrbc.org/gfx/genedoc/index.html>). Previously described pathogenic human (7,14), murine (7,12) and feline (13) mutations are marked with filled arrowheads, open arrowheads and open arrows, respectively; the position of the 295T>C variant is marked with a filled arrow [one additional mutation (15) lies upstream of the region illustrated]. (B) Sequencing of ZRS in a normal control (upper), patient OX3601 (middle) and the mother of patient OX3601 (lower). Position 295 is marked with an arrow. The mother of patient OX3601 is homozygous for the C allele (allele-specific drop out of the PCR was excluded by using three different combinations of primers). (C) MLPA chromatograms obtained from the mother of patient OX3601 (upper) and mixed control DNA (lower). The ZRS probe, indicated with an arrow, shows a normal complement of two copies.

based on a smaller sample size, the proportion of obligate carriers who are affected is  $3/10 = 0.3$ . We obtained a LOD score of 4.01 between the mutant allele and the phenotype in this family assuming a penetrance of the heterozygous mutant allele of 0.3 and a mutant allele frequency of  $1/10\ 000$ ; this was robust to variation in either the penetrance (between 0.2 and 0.5), or mutant allele frequency (up to  $1/150$ ), yielding LOD scores in the range 3.92–3.96. This provides statistical support that the phenotype in family OX3159 is linked to the 295C allele.

We used genotyping of four microsatellite loci (MS-A, -B, -C, -D) spanning a 1.1 Mb region of chromosome 7q36 flanking the ZRS to determine whether the three apparently unrelated families shared a common haplotype around this region. In the family of OX3601, the homozygote mother (295CC) was also homozygous at all four flanking microsatellite loci, and analysis of OX3159 and his mother showed an identical haplotype (allele sizes 253-274-233-303) on the disease chromosome (Fig. 4). In 30 English parent-child trios, this haplotype was not present in any of the 120

chromosomes, indicating that it is not common in this population. We could not obtain DNA from the parents of OX1925, however one copy of these same four alleles is also present in this individual; the probability of this occurring by chance is  $8.5 \times 10^{-4}$ , indicating that the same disease haplotype is likely to be present in OX1925 (Fig. 4). The demonstration of a common haplotype at these four multiallelic loci indicates a likely founder effect for the 295C allele, showing that it has segregated with the phenotype over many generations. This further strengthens the genetic evidence that either the 295C allele itself, or a nearby variant in linkage disequilibrium with it, is causally responsible for the abnormal phenotype.

**Analysis of transgenic mice**

To investigate whether the 295C allele might itself be pathogenic, we analysed ZRS reporter constructs in transgenic mice. In total eight embryos containing the 295C transgene showed robust staining of the ZPA in both forelimbs and



**Figure 2.** Clinical phenotype of patients heterozygous for the *ZRS* variant 295T/C. (A) Patient OX1925 with bilateral triphalangeal thumb. (B) Patient OX3159 with bilateral triphalangeal thumb and right pre-axial polydactyly.

hindlimbs, indicating that the construct produced reporter expression in the normal pattern of *Shh* (Fig. 5A). Of these, three embryos showed ectopic  $\beta$ -galactosidase staining in the anterior part of the developing forelimb bud (1 bilateral and 2 unilateral staining) at embryonic day (E)11.5 (Fig. 5B; range of expression patterns shown in Supplementary Material, Fig. S1B and D). No ectopic staining was present in any hindlimb, giving a total of 4/32 limb buds showing ectopic staining. Although the anterior limb bud staining was weak, it was never observed with the wild-type construct ( $n = 9$  mice, corresponding to 0/36 limbs, Supplementary Material, Fig. S1A), indicating a specific pathogenic effect of the 295C allele ( $P = 0.044$ , Fisher's exact test).

## DISCUSSION

In this work, we have demonstrated that 295T>C in the *ZRS* is not a neutral polymorphism as previously reported (7), but represents the major cause of triphalangeal thumb (3 of 5 cases) in our patient cohort from southern England. In contrast, only one of 34 patients (case OX3159 described here) with pre-axial polydactyly had a *ZRS* change, indicating that *ZRS* point mutations are overall a rare cause of pre-axial polydactyly. We failed to detect the 295C variant in 381 ethnically

matched controls, indicating that it is rare in this population; neither is it listed in dbSNP, indicating that it has not been detected in any surveys of genetic variation. Prompted by these findings, the data originally suggesting that the 295C variant was frequent in the Dutch population (7) were reassessed, and could not be replicated (E. de Graaff, personal communication). Given the microsatellite evidence for a single founder mutation in our three families, it will be interesting to determine whether this variant is present at low frequencies in other geographic areas, in which case it is likely to contribute substantially to cases of triphalangeal thumb.

The 295C variant is the 14th pathogenic single nucleotide change in the most highly conserved part of the *ZRS/Zrs* sequence to be identified in humans, mice or cats. Like all except two of the previously described changes, it affects a nucleotide that is conserved between human, mouse, chicken and *fugu*, being located at the last position in a sequence of 19 fully conserved residues (Fig. 1A). The *ZRS* provides one of the best examples for studying the biology and pathophysiology of regulatory sequence mutations acting at a distance, currently a major challenge in the molecular analysis of development.

The inconsistent and weak ectopic reporter staining compared with other transgenic constructs (13), and restriction to the forelimb, imply that the pathogenic effect of the 295C variant is mild. This reflects the clinical picture of this mutation, the most

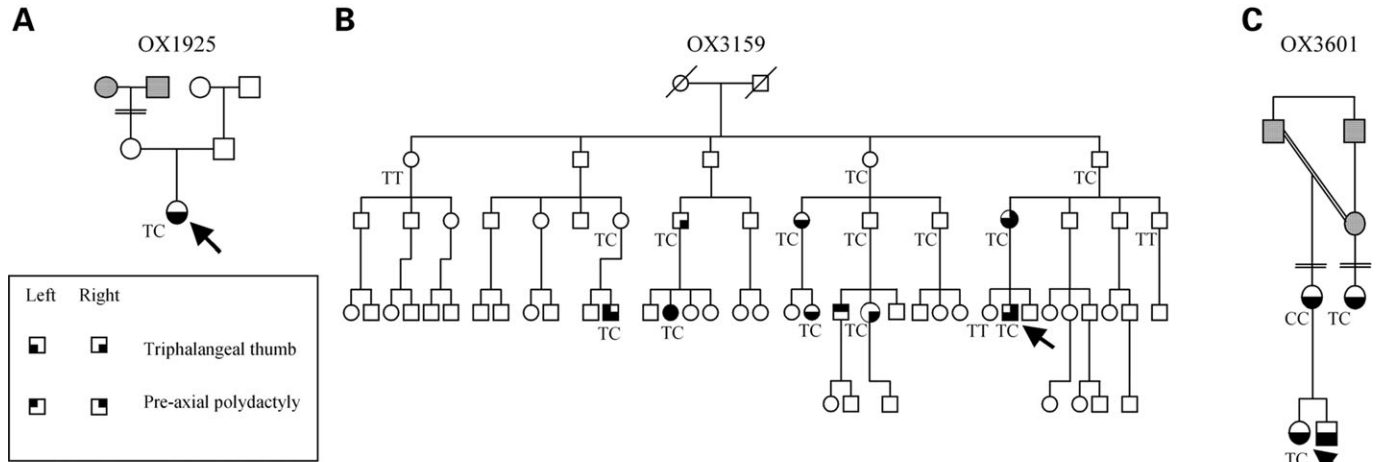

**Figure 3.** Pedigrees of (A) OX1925, (B) OX3159 and (C) OX3601. In each pedigree, the proband is marked with an arrow. Phenotypes for triphalangeal thumb and pre-axial polydactyly are indicated according to the key; grey shading of the whole symbol indicates unknown clinical status. Genotypes (T/C) at position 295 are shown below each individual in whom the genotype was determined; only those individuals who were genotyped were examined clinically.

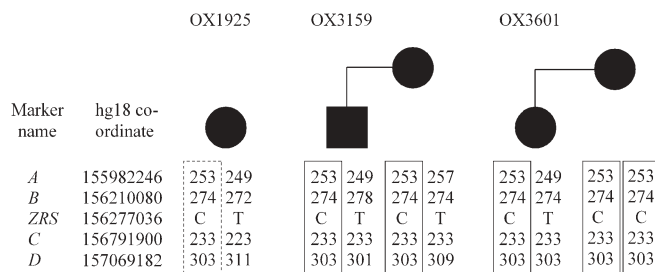

**Figure 4.** Microsatellite genotyping. The microsatellite markers MS-A, -B, -C and -D (Supplementary Material, Table S1) and the ZRS are shown in vertical order from centromere (top) to telomere. The shared haplotype is boxed (solid line). The haplotype of patient OX1925 is implied based on the hypothesis of a founder effect for the mutation, as the phase could not be determined (broken line).

common presentation being triphalangeal thumb without pre-axial polydactyly (including in the homozygous case), with a majority of heterozygotes being non-penetrant. The results extend further the previously observed correlation between the extent of  $\beta$ -galactosidase staining using the transgenic assay, and the severity of the phenotype associated with the corresponding mutation (13). Moreover the 295T>C mutation, which exclusively affects the forelimbs, was correspondingly shown by the transgenic assay to direct ectopic reporter gene expression only in the forelimb buds.

Recent evidence indicates that the *Zrs* acts as a target for transcription factor binding, specifically for Hoxd proteins (18); the identification of a signalling centre for another class of transcription factors, Tbx2/Tbx3, symmetrically present on both the anterior and posterior sides of the limb bud (19), raises the possibility that the point mutations in the ZRS confer, in a dominant fashion, competence for *Shh* expression at the ectopic site. This is predicted to alter the identity of the first digit from a thumb to a finger, as development of the thumb depends on expression of Gli3R in the absence of *Shh* (20). The predominant triphalan-

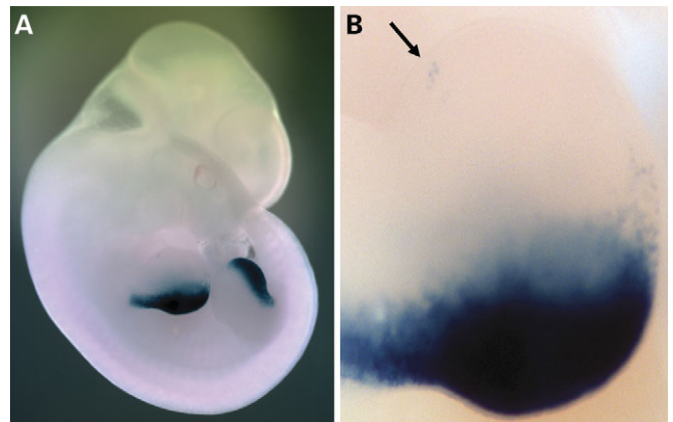

**Figure 5.** E11.5 mouse embryo transgenic for the ZRS 295C construct. (A) Whole embryo photograph reveals robust  $\beta$ -galactosidase staining in the ZPA of both the forelimb and hindlimb. (B) Close up of the forelimb shows weak ectopic anterior staining (arrow).

geal thumb phenotype described here (as opposed to more extensive pre-axial polydactyly) is consistent with weak and localized anterior SHH expression as observed in the transgenic analysis (Fig. 5).

## MATERIALS AND METHODS

### Clinical cohort and control samples

Following approval of this work from the Oxfordshire Research Ethics Committee C (C99.181), patients were recruited from the paediatric hand surgery clinic at Oxford Radcliffe Hospitals NHS Trust between 1999 and 2006. All patients and their parents who presented to the clinic with a congenital limb malformation requiring reconstructive surgery, and who gave informed consent, entered the study. At operation, a maximum of 5 ml of venous blood was collected, from which genomic DNA was isolated using

phenol/chloroform extraction. The three families described in this report all came from southern England and were of north European Caucasian origin. Unrelated, ethnically matched control samples were obtained from three sources: (i) ECACC Human Control DNA panels HRC-1, HRC-2, HRC-4 ( $n = 267$ ); (ii) Molecularly proven unaffected individuals from the UK and Ireland recruited into various genetic studies ( $n = 96$ ); and CEPH Caucasian samples ( $n = 18$ ). The parent-child trio samples for microsatellite genotyping were also of north European Caucasian origin.

### Molecular genetic analysis

The human *ZRS*, for which we use the numbering originally adopted by Lettice *et al.* (7), was screened in a total of 187 patients. Genomic DNA from the *ZRS* was amplified in two overlapping fragments (F3R3, F4R4) by PCR on a DNA Engine Dyad Peltier Thermal Cycler (Bio-Rad) using the primers and annealing temperatures shown in Supplementary Material, Table S1 and other reaction conditions as in Johnson *et al.* (21). The products were screened for heterozygous mutations using WAVE dHPLC (Transgenomic) at the temperatures indicated in Supplementary Material, Table S1, and any abnormally eluting fragments were subjected to DNA sequencing as previously described (21). The 295T/C genotype was obtained by digestion of a primer-mismatched amplicon (F5R5) with *AlwNI* (Supplementary Material, Table S1). Multiplex-ligation-dependent probe amplification was performed using synthetic oligonucleotide probes to the *ZRS* and six previously characterized control loci (MRC-Holland: <http://www.mrc-holland.com/pages/index-pag.html>) to exclude heterozygous deletion of the *ZRS* in the apparently homozygous individual (Supplementary Material, Table S2). Microsatellite genotyping was performed according to Johnson *et al.* (21) on four loci spanning a 1.1 Mb region of chromosome 7q36 flanking the *ZRS* (Supplementary Material, Table S1). Three of these (MS-A, MS-C, MS-D) were previously uncharacterized, whereas MS-B corresponds to marker HING1 in Heus *et al.* (22).

In addition to 295T>C we detected two other previously undescribed heterozygous *ZRS* variants (318T>A and 775G>C) in single patients. These were considered unlikely to be causative because the respective clinical presentations (unilateral post-axial polydactyly of the hands in the patient with 318T/A and bilateral first and second web syndactyly of the feet with tarso-talar coalition in the patient with 775G/C) fall outside the range of described phenotypes for *ZRS* mutations. In addition, we demonstrated that the same 318T/A genotype was also present in that patient's unaffected mother and maternal grandfather.

### Transgenic mice

Construction of 1.7 kb wild-type human clones (plasmid vector pBGZ40 #1230) containing the *ZRS* has been described previously (13). The 295T>C mutation was introduced using PCR-based site directed mutagenesis and verified by DNA sequencing of the complete construct. Constructs were excised from the vector by restriction endonuclease digestion with *SaII* and *NotI*, and purified by electroelution using an

Elutrap (Schleicher & Schuell). Transgenic mice were generated by pronuclear injection using standard techniques (7).  $G_0$  embryos were harvested at E11.5, fixed in 4% paraformaldehyde and stained as previously described (23).

### SUPPLEMENTARY MATERIAL

Supplementary Material is available at HMG Online.

### ACKNOWLEDGEMENTS

We are grateful to the families for their cooperation with this study, to D. Johnson for assistance with patient recruitment, S. Butler for cell culture, K. Clarke for DNA sequencing, S. Twigg and C. Babbs for help with genotyping and cloning, J. Ragoussis for providing the CEPH control DNA, P. Devenney for analysis of the transgenic mice and E. de Graaff for communication of unpublished data.

*Conflict of interest statement.* None declared.

### FUNDING

Wellcome Trust (074457 to D.F., 078666 to A.O.M.W.), UK Medical Research Council (L.A.L., R.E.H.).

### REFERENCES

- Wood, V.E. (1976) Treatment of triphalangeal thumb. *Clin. Orthop. Relat. Res.*, **120**, 188–199.
- Masuya, H., Sagai, T., Wakana, S., Moriwaki, K. and Shiroishi, T. (1995) A duplicated zone of polarizing activity in polydactylous mouse mutants. *Genes Dev.*, **9**, 1645–1653.
- Riddle, R.D., Johnson, R.L., Laufer, E. and Tabin, C. (1993) Sonic hedgehog mediates the polarizing activity of the ZPA. *Cell*, **75**, 1401–1416.
- Hill, R.E. (2007) How to make a zone of polarizing activity: insights into limb development via the abnormality preaxial polydactyly. *Dev. Growth Differ.*, **49**, 439–448.
- Sharpe, J., Lettice, L., Hecksher-Sorensen, J., Fox, M., Hill, R. and Krumlauf, R. (1999) Identification of sonic hedgehog as a candidate gene responsible for the polydactylous mouse mutant Sasquatch. *Curr. Biol.*, **9**, 97–100.
- Lettice, L.A., Horikoshi, T., Heaney, S.J., van Baren, M.J., van der Linde, H.C., Breedveld, G.J., Joosse, M., Akarsu, N., Oostra, B.A., Endo, N. *et al.* (2002) Disruption of a long-range cis-acting regulator for Shh causes preaxial polydactyly. *Proc. Natl Acad. Sci. USA*, **99**, 7548–7553.
- Lettice, L.A., Heaney, S.J., Purdie, L.A., Li, L., de Beer, P., Oostra, B.A., Goode, D., Elgar, G., Hill, R.E. and de Graaff, E. (2003) A long-range Shh enhancer regulates expression in the developing limb and fin and is associated with preaxial polydactyly. *Hum. Mol. Genet.*, **12**, 1725–1735.
- Dahn, R.D., Davis, M.C., Pappano, W.N. and Shubin, N.H. (2007) Sonic hedgehog function in chondrichthyan fins and the evolution of appendage patterning. *Nature*, **445**, 311–314.
- Sagai, T., Masuya, H., Tamura, M., Shimizu, K., Yada, Y., Wakana, S., Gondo, Y., Noda, T. and Shiroishi, T. (2004) Phylogenetic conservation of a limb-specific, cis-acting regulator of Sonic hedgehog (Shh). *Mamm. Genome*, **15**, 23–34.
- Sagai, T., Hosoya, M., Mizushima, Y., Tamura, M. and Shiroishi, T. (2005) Elimination of a long-range cis-regulatory module causes complete loss of limb-specific Shh expression and truncation of the mouse limb. *Development*, **132**, 797–803.
- Chiang, C., Litingtung, Y., Lee, E., Young, K.E., Corden, J.L., Westphal, H. and Beachy, P.A. (1996) Cyclopia and defective axial patterning in mice lacking Sonic hedgehog gene function. *Nature*, **383**, 407–413.
- Masuya, H., Sezutsu, H., Sakuraba, Y., Sagai, T., Hosoya, M., Kaneda, H., Miura, I., Kobayashi, K., Sumiyama, K., Shimizu, A. *et al.* (2007) A series

- of ENU-induced single-base substitutions in a long-range cis-element altering Sonic hedgehog expression in the developing mouse limb bud. *Genomics*, **89**, 207–214.
13. Lettice, L.A., Hill, A.E., Devenney, P.S. and Hill, R.E. (2008) Point mutations in a distant sonic hedgehog cis-regulator generate a variable regulatory output responsible for preaxial polydactyly. *Hum. Mol. Genet.*, **17**, 978–985.
  14. Gurnett, C.A., Bowcock, A.M., Dietz, F.R., Morcuende, J.A., Murray, J.C. and Dobbs, M.B. (2007) Two novel point mutations in the long-range SHH enhancer in three families with triphalangeal thumb and preaxial polydactyly. *Am. J. Med. Genet.*, **143A**, 27–32.
  15. Wang, Z.Q., Tian, S.H., Shi, Y.Z., Zhou, P.T., Wang, Z.Y., Shu, R.Z., Hu, L. and Kong, X. (2007) A single C to T transition in intron 5 of LMBR1 gene is associated with triphalangeal thumb-polysyndactyly syndrome in a Chinese family. *Biochem. Biophys. Res. Commun.*, **355**, 312–317.
  16. Klopocki, E., Ott, C.E., Benatar, N., Ullmann, R., Mundlos, S. and Lehmann, K. (2008) A microduplication of the long range SHH limb regulator (ZRS) is associated with triphalangeal thumb-polysyndactyly syndrome. *J. Med. Genet.* (in press) (PubMed ID: 18178630).
  17. Furniss, D., Critchley, P., Giele, H. and Wilkie, A.O.M. (2007) Nonsense-mediated decay and the molecular pathogenesis of mutations in *SALL1* and *GLI3*. *Am. J. Med. Genet.*, **143A**, 3150–3160.
  18. Capellini, T.D., Di Giacomo, G., Salsi, V., Brendolan, A., Ferretti, E., Srivastava, D., Zappavigna, V. and Selleri, L. (2006) *Pbx1/Pbx2* requirement for distal limb patterning is mediated by the hierarchical control of Hox gene spatial distribution and *Shh* expression. *Development*, **133**, 2263–2273.
  19. Nissim, S., Allard, P., Bandyopadhyay, A., Harfe, B.D. and Tabin, C.J. (2007) Characterization of a novel ectodermal signaling center regulating *Tbx2* and *Shh* in the vertebrate limb. *Dev. Biol.*, **304**, 9–21.
  20. Chiang, C., Litingtung, Y., Harris, M.P., Simandl, B.K., Li, Y., Beachy, P.A. and Fallon, J.F. (2001) Manifestation of the limb prepatterning: limb development in the absence of sonic hedgehog function. *Dev. Biol.*, **236**, 421–435.
  21. Johnson, D., Kan, S.H., Oldridge, M., Trembath, R.C., Roche, P., Esnouf, R.M., Giele, H. and Wilkie, A.O.M. (2003) Missense mutations in the homeodomain of HOXD13 are associated with brachydactyly types D and E. *Am. J. Hum. Genet.*, **72**, 984–997.
  22. Heus, H.C., Hing, A., van Baren, M.J., Joosse, M., Breedveld, G.J., Wang, J.C., Burgess, A., Donnis-Keller, H., Berglund, C., Zguricas, J. *et al.* (1999) A physical and transcriptional map of the preaxial polydactyly locus on chromosome 7q36. *Genomics*, **57**, 342–351.
  23. Mackenzie, M.A., Jordan, S.A., Budd, P.S. and Jackson, I.J. (1997) Activation of the receptor tyrosine kinase Kit is required for the proliferation of melanoblasts in the mouse embryo. *Dev. Biol.*, **192**, 99–107.