

Recycling of Materials in Civil Engineering

by

Margaret Mary O'Mahony

A Thesis submitted to the
University of Oxford for the
Degree of Doctor of
Philosophy

New College

Trinity Term, 1990.

ABSTRACT

Margaret Mary O'Mahony
New College

Doctor of Philosophy
Trinity Term, 1990.

Recycling of Materials in Civil Engineering

Although Britain is relatively rich in natural aggregate reserves, planning approvals to develop new quarries are running at about half the rate of aggregate extraction. The use of secondary materials, such as recycled aggregate, might not create a major source of aggregate but if secondary materials were used in less demanding situations, the quantity of natural aggregate required by the construction industry would be reduced.

This dissertation reports mainly on laboratory tests conducted on crushed concrete and demolition debris to examine the potential use of these materials in new construction. Standard aggregate tests were conducted on the materials to check their compliance with the Specification for Highway Works (1986), particularly for use as aggregate in road sub-base layers. A more detailed examination of the aggregates was conducted with regard to CBR, shear strength and frost susceptibility where the influences of moisture content, density and particle packing on these properties were investigated. One part of the study involved examining the use of recycled aggregate as the coarse aggregate fraction in new concrete.

An analysis of the shear strength data was conducted using the dilatancy index defined by Bolton (1986). From the frost susceptibility results, it was concluded that further work would be required in this area to determine the main factors which influence the frost heave of recycled aggregates. The recycled aggregate concrete compared well with the natural aggregate concrete and appeared to be of superior quality than that produced in other research. During the study, it became evident that the recycled aggregates could perform as well as limestone in most cases and therefore could be considered for many potential uses. Some recommendations are presented at the end of this dissertation for the development of a standard on recycled materials which would help to promote the use of recycled aggregates in the construction industry in Britain.

To Bridie and Jerry O'Mahony

*"Holy Spirit light all roads so
that I can attain my goal"*

CONTENTS

ABSTRACT

Contents	(i)
Acknowledgements	(iii)
List of Terms and Symbols	(iv)

CHAPTER 1 INTRODUCTION	1-1
-------------------------------------	-----

CHAPTER 2 RECYCLING - PROCESSES AND CURRENT STANDARDS	2-1
2.1 Introduction	2-1
2.2 The recycling process	2-3
2.2.1 Crushers	2-6
2.2.2 Sorting techniques	2-8
2.3 State-of-the-art and standards	2-11
2.3.1 Britain	2-12
2.3.2 The Netherlands	2-16
2.3.3 Denmark	2-18
2.3.4 Belgium	2-19
2.3.5 Japan	2-20
2.3.6 Germany	2-22
2.3.7 United States of America	2-23

CHAPTER 3 STANDARD AGGREGATE TESTS	3-1
3.1 Introduction	3-1
3.2 Sub-base requirements	3-2
3.3 Particle grading	3-4
3.4 Plasticity	3-12
3.5 10% fines test	3-13
3.6 Specific gravity	3-14
3.7 Density tests on site	3-17
3.8 Impurities	3-22
3.9 Discussion	3-23
3.10 Conclusions	3-23

CHAPTER 4 COMPACTION AND CALIFORNIA BEARING RATIO TESTS	4-1
4.1 Compaction	4-1
4.1.1 Introduction	4-1
4.1.2 Compaction apparatus and test procedures	4-2
4.1.3 Results	4-10
4.2 California Bearing Ratio	4-18
4.2.1 Introduction	4-18
4.2.2 The CBR test	4-19
4.2.3 Results	4-24
4.2.4 Analysis	4-36
4.3 Discussion	4-40
4.4 Conclusions	4-41

CHAPTER 5 DIRECT SHEAR TESTS	5-1
5.1 Introduction	5-1
5.2 300mm shear box	5-1
5.3 Preparing the samples	5-4
5.4 Running the shear box test	5-5

5.5	Test conditions of aggregates	5-6
5.6	Leighton Buzzard sand tests	5-11
5.7	Results	5-12
5.8	Shear box tests for road sub-base materials	5-23
5.9	Analysis	5-25
5.9.1	The flow rule analysis	5-26
5.9.2	Analysis using dilatancy index	5-31
5.10	Discussion	5-38
5.11	Conclusions	5-40
CHAPTER 6	FROST SUSCEPTIBILITY TESTS	6-1
6.1	Introduction	6-1
6.2	The explanation of frost heave	6-2
6.3	Development of the frost heave test	6-4
6.4	Frost heave testing	6-5
6.4.1	Preparing the test specimens	6-5
6.4.2	Test conditions	6-9
6.4.3	Setting up the self-refrigerating unit	6-12
6.4.4	Placing the specimens in the SRU	6-14
6.5	Classification of materials	6-16
6.6	Results	6-17
6.7	Discussion	6-25
6.8	Conclusions	6-27
CHAPTER 7	RECYCLED AGGREGATE CONCRETE	7-1
7.1	Introduction	7-1
7.1.1	Mix design	7-1
7.1.2	Workability	7-2
7.1.3	Strength of concrete	7-3
7.1.4	Young's modulus	7-3
7.1.5	Shrinkage and creep	7-4
7.1.6	Impurities	7-4
7.2	An examination of recycled aggregate concrete	7-6
7.2.1	Mix design of recycled aggregate concrete	7-6
7.2.2	Workability of concrete mixes	7-8
7.2.3	Compressive strength results	7-8
7.2.4	Young's modulus results	7-13
7.2.5	Shrinkage	7-14
7.2.6	Creep	7-18
7.3	Discussion	7-22
7.4	Conclusions	7-25
CHAPTER 8	DISCUSSION	8-1
8.1	Global review of test results	8-1
8.2	Recycling in civil engineering	8-9
8.3	Possible uses of recycled materials	8-12
8.4	Estimates of errors	8-15
CHAPTER 9	CONCLUDING REMARKS	9-1
9.1	Conclusions	9-1
9.2	Suggestions for a standard on recycled materials in Britain	9-5
9.3	Further research	9-6
REFERENCES	R-1

Acknowledgements

The Institute of Demolition Engineers and Dr. Peter Lindsell are acknowledged for the initiation of this research project, their support and the funding of this work in the early stages.

I would like to thank the University of Oxford and New College for financial assistance in my third year. I am also grateful for the financial support of the Geotechnical Consulting Group as part of a contract from the Transport and Road Research Laboratory.

Hughes and Salvidge Ltd., Foster Yeoman Ltd. and Fitzpatrick & Sons Ltd. are thanked for the provision of materials.

I extend my gratitude to everyone who was involved with my work, particularly the following:-

Dr. Mike Mulheron at the University of Surrey for his constant support and encouragement.

Members of the Civil Engineering Department at the University of Surrey for their help and assistance when needed.

Members of the Transport and Road Research Laboratory, particularly Dr. M. P. O'Reilly, Mr. Ken Brady, Mr. Guy Watts and the other members of the Ground Engineering Unit for their support and help.

Mr. Bill Birch and his assistants in the Maintenance Section of the Department of Engineering Science at the University of Oxford who were always obliging when their assistance was required.

I am privileged to have been a member of the Soil Mechanics Group at the University of Oxford and am very grateful to Professor Peter Wroth for taking a personal interest in my work and welfare during my stay in Oxford. I would also like to express my gratitude to past and present members of the Soil Mechanics Group for making it a pleasant place in which to work. Dr. Richard Jewell deserves an extra note of thanks for his advice and guidance.

I would like to express my sincere gratitude to my supervisor Dr. George Milligan who was instrumental in providing me with the chance to complete this research, for his organisation of funding, for his guidance and support at all times and for his constructive criticism and advice during the preparation of this thesis.

Finally, I would like to thank my family, particularly my parents to whom I am indebted for their continual support, encouragement, understanding and patience over many years.

List of Terms and Symbols

Crushed concrete	Clean aggregate obtained from the break up, crushing and screening of concrete slabs from road pavements.
Demolition debris	Aggregate obtained from the demolition, crushing and screening of demolition rubble. This recycled product can contain many constituents as well as concrete such as brick, glass, asphalt and wood.
Recycled aggregate	Aggregate produced from the break up, crushing and screening of any demolition waste.
Recycled aggregate concrete	Concrete made using recycled aggregate in either of the coarse or fine aggregate fractions.

A	Area of shear box
c	Cohesion
CBR	California bearing ratio
CIV	Clegg impact value
CLD	Constant level device
C_u	Coefficient of uniformity
d	Depth of footing
dx	Increment of shear displacement
dy	Increment of vertical displacement
dy/dx	Rate of dilation
dγ_{yx}	Increment of shear strain
dε_{yy}	Increment of vertical strain
dε_{yy}/dγ_{yx}	Rate of dilation
D₁₀	Diameter at which 10% of the material is finer
D₅₀	Diameter at which 50% of the material is finer
D₆₀	Diameter at which 60% of the material is finer
e	Voids ratio

e_{\max}	Maximum voids ratio
e_{\min}	Minimum voids ratio
g	Gravitational constant
G_s	Specific gravity
h	Height of deforming zone in shear box sample
H	Height of shear box
I_d	Relative density
I_r	Dilatancy index
L	Length of shear box
LVDT	Linear variable differential transformer
m	Constant
MC	Moisture content
N_c, N_q and N_γ	Bearing capacity factors
OMC	Optimum moisture content
OPC	Ordinary Portland cement
p'	Mean effective stress
P_s	Shear force
P_v	Vertical force
Q	Constant depending on material type, as defined by Bolton (1986)
q_u	Ultimate bearing capacity
r	Radius of footing
R	Constant = 1
s	Mean principal stress
S.D.	Standard deviation
SRU	Self-refrigerating unit
t	Maximum shear stress
V_{fw}	Proportion of volume occupied by free water
V_s	Proportion of volume occupied by solids
W_a	Water absorption

w/c	Water/cement
γ	Unit weight
ρ_b	Bulk density
ρ_d	Dry density
$\rho_{d,peak}$	Peak dry density
σ_1	Major principal stress
σ_2	Intermediate stress
σ_3	Minor principal stress
σ_v	Vertical stress
σ_{yy}	Vertical stress measured on central plane
τ	Shear stress
τ_{yx}	Shear stress measured on central plane
τ/σ_v	Stress ratio
$(\tau/\sigma_v)_p$	Peak stress ratio
τ_{yx}/σ_{yy}	Stress ratio measured on central plane
ϕ	Angle of internal friction
ϕ_{cv}	Critical state plane strain angle of friction
ϕ_{ds}	Direct shear angle of friction
ϕ_{ps}	Plane strain angle of friction
$(\phi_{ds})_{cv}$	Critical state direct shear angle of friction
$(\phi_{ds})_p$	Peak direct shear angle of friction
$(\phi_{ps})_p$	Peak plane strain angle of friction
ψ	Angle of dilation

CHAPTER 1

INTRODUCTION

Recycling of demolition rubble is not a new idea and some reported cases of recycling demolition waste date back to the 2nd World War. In several countries, particularly in Europe, it is an important process which is used to produce a useful source of aggregate for the construction industry. Britain has been slow to adopt recycling on a large scale because it possesses substantial mineral reserves. However, planning approvals to develop new quarries are running at only half the rate of aggregate extraction, which means that in the future the rate of production of crushed rock will be too slow to meet the aggregate demand of the construction industry. The use of secondary materials may not completely remove the problem of the resulting shortage of aggregate but it could alleviate it. The more successful cases of recycling reported in Europe are those where the recycling plant is located in a large city and where there is likely to be sufficient demolition to provide a consistent supply of rubble.

The increasing price of land in recent years has led to high dumping costs at landfill sites, particularly in London. Demolition contractors, wishing to dispose of rubble, have found that it is now more expensive to dump demolition waste than to recycle it. Some demolition contractors unfortunately resort to fly-tipping i.e. tip rubble illegally on private or public land, to dispose of what is a potentially valuable material. To promote recycling, incentives should be given to demolition contractors by installing recycling plants in urban locations and allowing the use of recycled aggregate instead of natural aggregate for some purposes.

The research project commenced with a study of the equipment which was available to demolition contractors for the recycling of demolition rubble. In the Netherlands, recycled

products are used almost exclusively as aggregate for unbound layers in road construction because natural aggregate is scarce. Consequently the Dutch have refined the recycling process to produce good quality recycled aggregate. The recycling plants in Britain were compared with those in operation in the Netherlands and were found to be less well equipped with cleaning and sorting devices.

The recycled products from some recycling plants were examined and their physical properties were compared with those of natural aggregate. The ability of the recycled aggregates to comply with existing specifications, particularly for use as granular sub-base material, was also checked.

Shortly after the research project commenced, the opportunity arose to conduct a field trial on a stretch of road in the development of Portsmouth Marina. Demolition debris and limestone were placed in the top part of the capping layer and the densities and gradings of the materials were compared. It would have been more useful if the materials could have been placed in the sub-base layer but the client would not permit this.

The research project progressed into a detailed examination of the properties of crushed concrete and demolition debris. The crushed concrete was a clean aggregate obtained from the break up, crushing and screening of concrete slabs during repair work on the M25 motorway at the Potters Bar junction and the demolition debris was an aggregate obtained from the recycling of demolition rubble and therefore included a random mix of materials. These aggregates were compared with a carboniferous limestone from a quarry in Somerset.

The influence of the inclusion of particles larger than 37.5mm on compaction was examined in a 300mm diameter mould and the results of more conventional compaction tests were also studied. The relationship between dry density and moisture content obtained from these

tests formed the basis for an investigation into the CBR of the materials in different test conditions. A comparison was made between CBR values calculated using the respective friction angles of the materials and the measured CBR values.

The shear strength of the aggregates was examined in a 300mm x 300mm x 179mm shear box located at the Transport and Road Research Laboratory. The influence of density and vertical stress on the shear strength of the aggregates was investigated and an analysis was conducted on the test data using the dilatancy index defined by Bolton (1986).

Due to the strong emphasis on the use of recycled materials for road sub-base in the research project and because of the restrictions on the frost susceptibility of materials to be placed within 450mm of a road surface, the frost susceptibility of the recycled materials was studied. The influence of the initial moisture content on frost heave was also examined to observe whether frost heave was dependent, not only on the flow of water into the material from below, but also on the initial moisture content.

The major part of the work was conducted with a view to using the recycled aggregates in unbound conditions e.g. as road sub-base or fill to structures. In addition, a study was carried out on the properties of concrete made using crushed concrete as the coarse aggregate fraction. Tests were performed on fresh and hardened concrete and the performance of recycled aggregate concrete was compared with that of concrete made using a Thames valley gravel.

From the results of the tests conducted on the aggregates in unbound conditions, some conclusions were made on the best conditions in which to place recycled aggregates on site. At the end of this dissertation, the strengths and weaknesses of recycled materials are discussed and some suggestions are made for the improvement of material which does not

comply with current specifications. On a more general note, some proposals are made to the construction industry on how to come to terms with and accept recycled material as a useful aggregate source.

Although some recycled materials are allowed to be used for certain purposes in Britain, no standard includes definitions of these materials or the levels of acceptable contamination. The main aim of the research project was to examine the properties of recycled materials and it was expected that the conclusions would be a basis from which the production of a standard for recycled aggregates would develop.

CHAPTER 2

RECYCLING - PROCESSES AND CURRENT STANDARDS

2.1 Introduction

In 1985, approximately 191 million tonnes (mt) of crushed rock, sand and gravel were used as aggregate for construction in England and Wales (DoE, MPG6, 1989). This report will be referred to hereafter as MPG6 (1989). Aggregate consumption had increased to 202mt by 1986 and is expected to rise to 226mt by 1995 and 245mt by 2005 (MPG6, 1989). In 1972, the British government appointed an advisory committee on aggregate (the Verney Committee) to consider the future supply of aggregate for the construction industry. This committee concluded that the object of a policy for aggregates should be to achieve an adequate and steady supply of material to meet the needs of the construction industry at minimum financial and social cost (the Verney Report, 1976). The committee realised that the environmental nuisance caused by aggregate production and distribution could not be totally avoided but it suggested that every effort should be made to keep damage to the environment to a minimum.

It was stated in MPG6 (1989) that the use of secondary materials such as blast furnace slag, power station ash and aggregates produced from the recycling of construction waste, such as crushed concrete, should be encouraged. If the reuse of waste was increased, the demand for conventional aggregate would be reduced. Therefore there would be less tipping and at the same time there would be a reduction in the amount of land required for the extraction of natural aggregate. It was reported in MPG6 (1989) that waste material was unlikely to become a major source of aggregate because of transport considerations. MPG6 (1989) appears to have placed the emphasis on the wrong reason because there are also transport

problems for natural aggregate producers e.g. a source in Scotland providing aggregate for construction in London. The main reason is more likely to be the lack of an organised approach to recycling.

The main areas currently supporting recycling in Britain are London and the South-East with virtually no recycling being carried out in Wales or Scotland. Seventy per cent of demolition waste produced in Britain is from England (Mulheron, 1988). It was estimated by Environmental Resources Ltd. (1980) that by 1990 approximately 27mt of concrete waste and 16mt of brick waste would be dumped each year at land fill sites in Britain. If this material could be recycled for use in the construction industry, the environment would benefit in two ways. First, the amount of land needed for dumping would be reduced and secondly there would be a slower release of land required for aggregate extraction.

Research into the recycling of construction material has been conducted extensively in some European countries and in the United States. This research was prompted by the possible environmental and economic benefits of reusing such material. In Britain, recycled materials have been used as fill and hard-core but have not been used very much in the more selective areas of construction. Recently, however, there have been comments in the media (New Civil Engineer, 1989) about the possible shortages of aggregate in the future, not because natural aggregate reserves will become depleted but because the release of land is becoming more restricted due to the detrimental effect of quarrying on the environment. Britain, in comparison with some other European countries such as the Netherlands, is relatively rich in natural aggregate and this may be partly the reason why clients select conventional aggregate in preference to recycled aggregate.

2.2 The recycling process

A recycling plant is quite similar to a plant producing crushed natural aggregate. The closed system, illustrated in Figure 2.1, is the layout which is normally recommended for the production of recycled aggregate (Hansen, 1985). The open system, which is shown in Figure 2.2, has greater capacity but the maximum particle size is less well defined and this can lead to larger variations in the size of the end product. As clean concrete is not always available, provision must be made in a recycling plant for the extraction of contaminants from the material. The layout of a stationary recycling plant, which produces a high quality product, is shown in Figure 2.3.

Recycling plants can be mobile or stationary. Normally a mobile plant consists of one crusher and some sorting devices. The removal of contaminants and steel is mainly conducted by hand sorting and self-cleaning electromagnets. In some cases mobile plants can consist of two crushers, as was demonstrated by Somerset County Council on the repair of the Taunton Bypass in 1989. The main advantages of a mobile installation are as follows (Lindsell and Mulheron, 1985):-

- (i) Transport in the vicinity of the site is reduced, particularly if the rubble is produced, recycled and reused on the same site.
- (ii) Disposal costs are reduced because of less dumping.
- (iii) The local supply of aggregate is increased and therefore less aggregate needs to be imported into the area.
- (iv) The recycling plant can be moved relatively easily to another site.

The disadvantages of a mobile recycling plant are as follows:-

- (i) There are limited cleaning facilities in this type of installation and therefore the recycled product is normally of low quality.

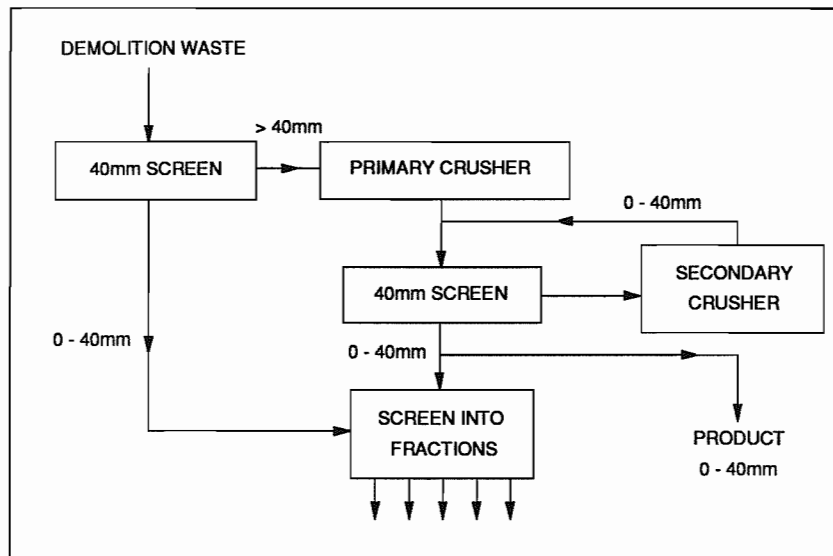

Figure 2.1 Flow chart of a typical closed system recycling plant, set up to produce a grading of 0 - 40mm (after Hansen, 1985)

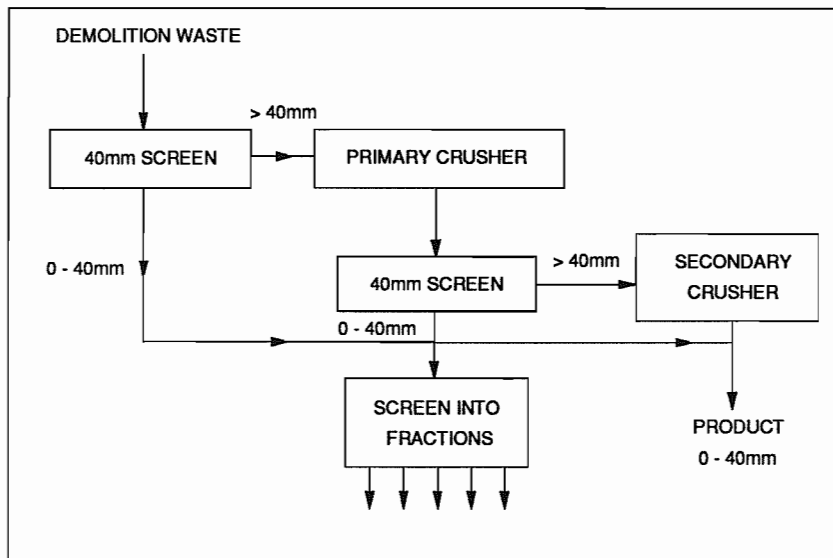

Figure 2.2 Flow chart of a typical open system recycling plant, set up to produce a grading of 0 - 40mm (after Hansen, 1985)

- (ii) The recycling plant can cause high levels of dust and noise which would be unacceptable close to residential areas.
- (iii) This type of plant can only be used if there is a sufficient quantity of rubble on the site to justify the expense of setting up the recycling plant.

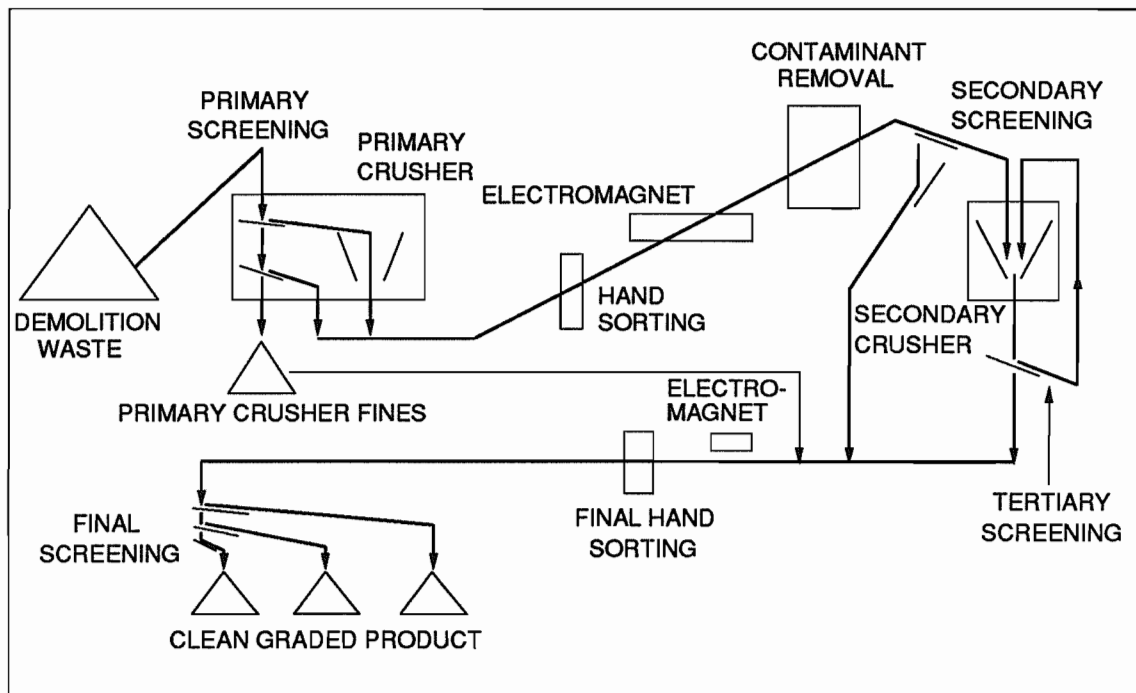

Figure 2.3 Typical layout of a stationary recycling plant (after Lindsell and Mulheron, 1985)

A stationary recycling plant usually incorporates a large primary crusher working in conjunction with a secondary crusher and also includes various cleaning and sorting devices to produce high quality aggregate. In Britain, this type of plant normally combines two jaw crushers and is capable of yielding a range of graded products. Self-cleaning electromagnets, sieves and hand sorting are employed to produce a relatively clean recycled aggregate from a mixed and contaminated input material (Mulheron, 1988). A Dutch stationary plant is illustrated in Plate 2.1. Recently some stationary recycling plants have been set up in

Manchester, Birmingham and Portsmouth and approximately six have been installed in London. The main advantages of a stationary recycling plant are as follows (Lindsell and Mulheron, 1985):-

- (i) The recycling plant is capable of producing a high quality product.
- (ii) The efficiency of the plant is better than that of a mobile recycling plant because different recycled products of various gradings can be produced.
- (iii) Disposal costs are reduced because of less dumping.
- (iv) The local supply of aggregate is increased and therefore less aggregate needs to be imported into the area.

The disadvantages of a stationary recycling plant are as follows:-

- (i) The initial investment of setting up such a plant can be in excess of several million pounds.
- (ii) There is an increase in transport in the vicinity of the recycling plant.
- (iii) The recycling plant can cause an increase in noise levels.
- (iv) The efficiency of production depends on the local supply of rubble and unfortunately demolition contractors are rarely able to ensure a constant supply of demolition waste.

2.2.1 Crushers

The crushers which are used at present for the recycling of rubble were not designed or developed specifically for the purpose. The majority of crushers originate from coal and ore processing or from natural stone crushing plants (Boesman, 1985). Modifications have been made to these crushers to alter the degree of size reduction and the particle size distribution, to reduce wear and to prevent high levels of dust and noise.

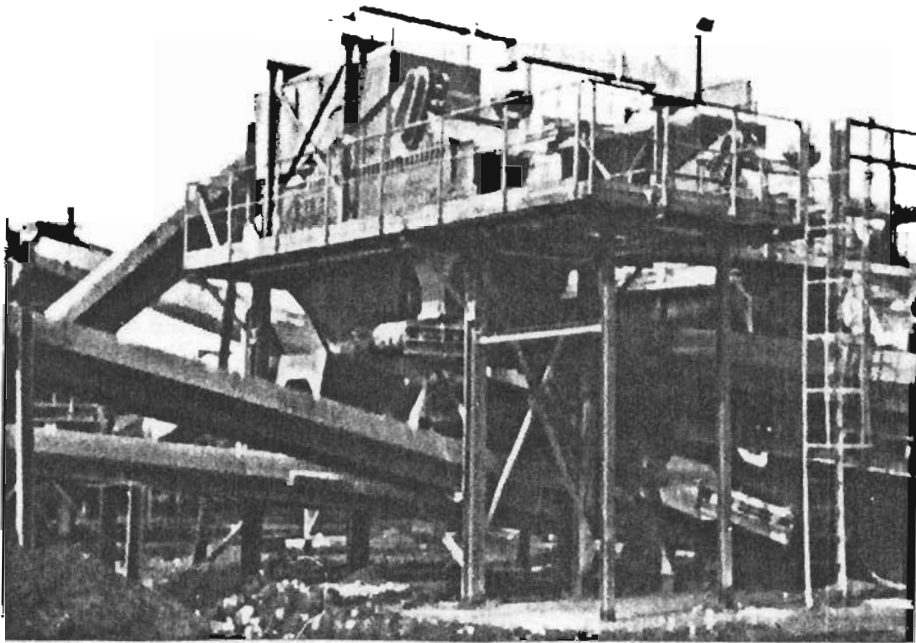

Plate 2.1 A stationary recycling plant consisting of a primary jaw crusher and a secondary impact crusher

The suitability of three types of crushers for crushing construction waste was investigated by Boesman (1985). They included a jaw crusher, an impact crusher and a cone crusher. A cone crusher cannot accept material which is larger than 200mm in size and therefore only jaw and impact crushers should be considered for use as primary crushers (Boesman, 1985).

A jaw crusher consists of two plates fixed at an angle - one plate remains stationary while the other plate oscillates back and forth relative to the fixed plate. This action crushes material passing between the two plates. The degree of particle size reduction depends on the maximum and minimum size of the gap at the base of the plates. An impact crusher breaks the material up by striking it with a high speed rotating impactor which imparts a

shearing force on the rubble. Almost all recycling plants in Britain incorporate jaw crushers whereas recycling plants in Europe usually employ impact crushers (Lindsell and Mulheron, 1985).

The particle size distribution of the output material is affected by the type of crusher used (Boesman, 1985). In general, the impact crusher has a large reduction factor. The reduction factor is defined as the ratio of the particle size of the input to the particle size of the output material (Lindsell and Mulheron, 1985). A jaw crusher crushes only a small proportion of the original aggregate particles but an impact crusher crushes mortar and aggregate particles alike and for the same maximum size of particle generates twice the amount of fines. One advantage of the impact crusher is its high efficiency and relatively low sensitivity to material which cannot be crushed e.g. reinforcement. Consequently, impact crushers suffer high wear and tear which means that maintenance costs are high.

2.2.2 Sorting techniques

There are several methods of removing contaminants from demolition debris and they can be separated into two groups, (i) pre-crushing separation and (ii) post-crushing separation.

(i) Pre-crushing separation

Rubble can be sorted while a structure is being demolished but this type of separation can be expensive and time consuming for the demolition contractor and therefore is not normally carried out unless there are definite incentives on a particular demolition site. Most sorting takes place when the rubble reaches the recycling plant. When the waste arrives, it is stockpiled according to its major constituent or the amount of contamination present. The plant operator can therefore deal with very large or undesirable material separately (Lindsell and Mulheron, 1985). This initial sorting

can help to optimise crushing time because e.g. a large quantity of clean rubble which has accumulated in a stockpile can be crushed in a single, continuous crusher run.

At most recycling installations, primary screening is conducted by passing the rubble over a sieve before it reaches the primary crusher. Therefore material, which is already of the required size and which needs no further crushing, bypasses the primary crusher. This fraction is usually screened further to remove soil and other fine contaminants and the remainder is returned at a later stage to the recycling process.

(ii) Post-crushing separation

After the rubble has been crushed, a number of contaminant removal techniques can be applied to the material. The simplest method is hand sorting which involves removing contaminants by hand from the conveyor belts. The efficiency of this system depends on the concentration of the operator and on the speed of the conveyor belt. The main advantage of this method is that the human eye can recognise contaminants which would be difficult to remove by mechanical means e.g. glass.

Automatic methods of contaminant removal include the following:-

a) Electromagnetic removal of steel

Self-cleaning electromagnets for the removal of steel are commonly employed in recycling plants. Usually the magnet is located across the conveyor belt between the primary and secondary crushers. The efficiency of the magnet depends on the distance between the magnet and the conveyor belt, the conveyor belt speed, the density of the passing demolition debris and the angle at which

the magnet is inclined to the conveyor. A magnet works most efficiently when it is positioned directly above and parallel to a slow moving, lightly loaded conveyor belt (Lindsell and Mulheron, 1985).

b) Dry sieving

Dry sieving can be used to separate the material into fractions which can be recombined later to produce well graded aggregate. The main disadvantage of dry sieving methods is the production of large quantities of dust. According to the Building Contractors Society of Japan (1981), coarse materials can be separated more efficiently by using inclined screens vibrating at low frequencies and large amplitudes while horizontal screens, vibrating at high frequencies and small amplitudes, are more effective for separating fine material.

c) Wet separation

Low density contaminants can be removed from demolition debris using an aquamator (Lindsell and Mulheron, 1985). This method of separation is conducted by placing the material in a tank full of water. The water in the tank is circulated at a fast rate and currents are set up by water jets. Wood and other lightweight impurities which float in water are removed by combs which move from one end of the tank to the other. This cleaning technique is normally restricted to material of particle size greater than 10mm because of the excessive quantities of sludge which would be produced if material from a smaller fraction was added to the tank.

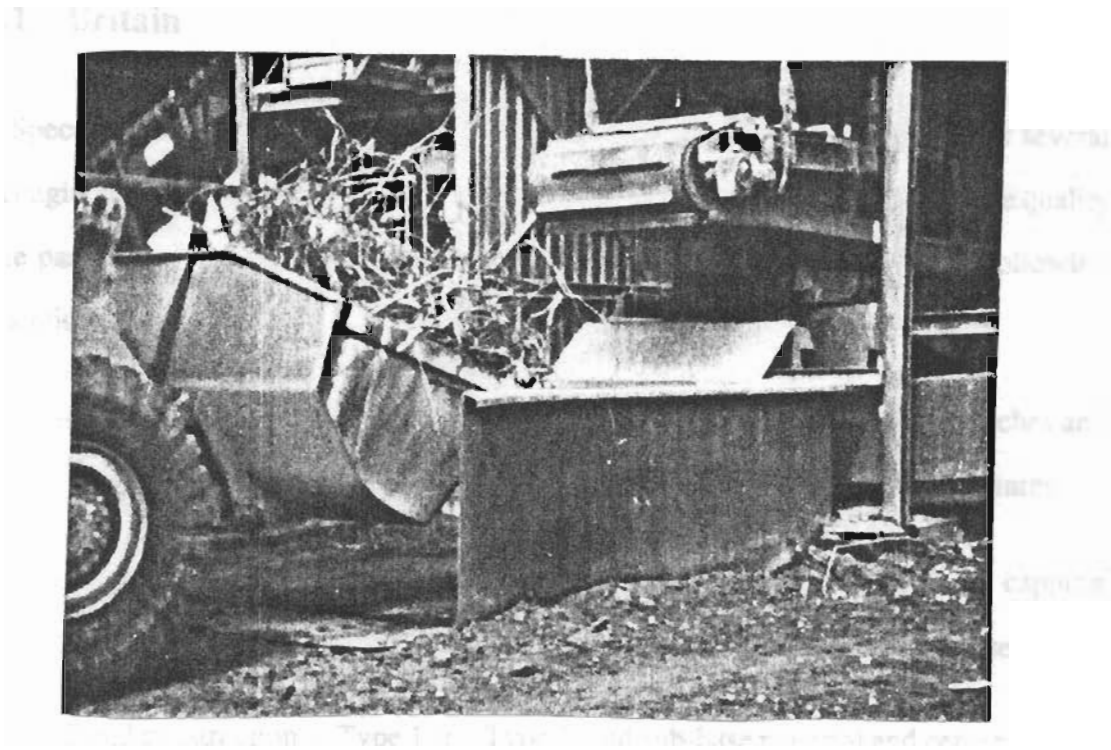

Plate 2.2 The removal of steel after electromagnetic separation from the rubble

2.3 State-of-the-art and standards

To increase the use of recycled aggregate in construction, present standards in Britain must be modified or updated and where possible new standards should be introduced to help in the promotion of recycled aggregates. In 1992, there is likely to be a common European standard for recycled materials but at present some European countries are more advanced than others in their appreciation of recycling. The state-of-the-art in recycling in some countries is described in this section.

2.3.1 Britain

The Specification for Highway Works (1986) allows the use of crushed concrete for several civil engineering purposes and it could be considered for many more depending on the quality of the particular recycled product. Crushed concrete is allowed for use in the following applications:-

- a) Drainage works - bedding and surrounding of pipes, backfilling of trenches and filter drains, backfilling to pipe bays and backing to earth retaining structures.
- b) Earthworks - fill to structures, fill above structural concrete foundations, capping material, cement or lime stabilised capping material and earthworks noise bunds.
- c) Road construction - Type 1 and Type 2 road sub-base material and cement bound materials of grade CBM1 and CBM2, as defined in the Specification for Highway Works (1986).

One of the main aims of this research is to examine the ability of recycled aggregate to perform in the unbound aggregate layer of a flexible road pavement i.e. as sub-base material. The sub-base lies between the basecourse and the subgrade, as can be seen in Figure 2.4. It performs three main functions.

- a) It acts as a structural component of the pavement.
- b) It is not frost susceptible and it insulates the subgrade against freezing.
- c) It provides a working platform for construction traffic.

The stresses generated in a road pavement by traffic decrease rapidly with depth which implies that the stresses exerted on the sub-base are only slightly greater than those on the subgrade. If the sub-base was designed on this basis, the material used would only need to

be a little stronger than the subgrade. However, the third of the functions listed above, rather than the first, determines the minimum sub-base strength because after compaction the sub-base should be able to support construction traffic. If the sub-base suffers large deformations during this time, it might be impossible to place the overlying layers and permanent damage could be suffered by the subgrade.

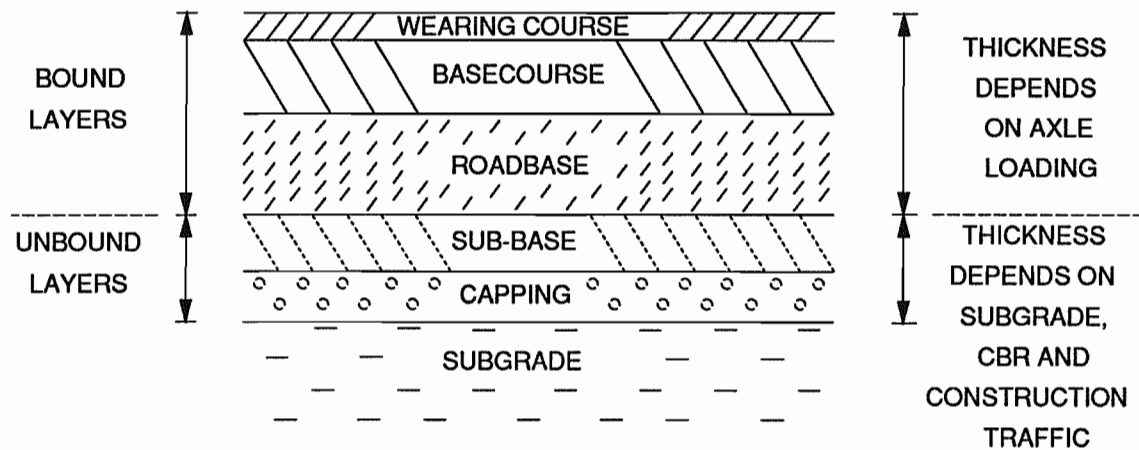

Figure 2.4 Road pavement structure (after Biczysko, 1989)

Brown (1985) concluded that elastic stiffness and permanent deformation resistance are the most important properties of a compacted, unbound layer in a road pavement and are controlled by the amount of drainage allowed in the material. Jones and Jones (1989) pointed out that strength and stiffness are improved if the pore pressures, which are generated on loading, dissipate quickly. Good drainage could help to achieve this and the risk of damage due to frost would also be reduced. It appears from work conducted by Sweere (1989) that recycled aggregate would provide a stiffer layer than conventional aggregate because it possesses a self-cementing quality which is apparent a few weeks after placement.

Jones (1985) and Biczysko (1985) discussed the contradiction in the functions of a sub-base. The material must be densely packed to produce a stiff layer while the sub-base also needs

to be a drainage layer of high permeability. A good drainage layer also has the advantage of low capillary rise which reduces the possibility of frost heave (Jones, 1985). The solution to the apparent contradiction in the functions of a sub-base is to make more use of an open packed capping layer for good drainage and to construct the sub-base as a dense, stiff layer.

In situ pavement recycling has developed into a useful method of reusing construction waste and its description is included in the Specification for Highway Works (1986). This process involves crushing damaged concrete pavement with a specially designed machine which pulverises the concrete slab as it proceeds along the length of a pavement. Cement is then spread on the crushed material followed by water which is delivered from a spray bar connected to a water tank. The material is mixed and compacted by several passes of a vibrating roller and the recycled layer is then covered with a surface dressing (Kennedy and Clark, 1986).

The reputation of recycled material in Britain could be improved if a standard was produced to regulate the quality of both crushed concrete and other recycled materials, such as demolition debris. BS 6543 (1985), the use of industrial by-products and waste materials in building and civil engineering, includes some comments on the use of waste materials in both road construction and building and it considers crushed concrete for sub-base and basecourse applications. It also approves, in principle, the use of clean crushed concrete and demolition debris for use as aggregate in concrete of low strength.

No standard in Britain exists in which crushed concrete, demolition debris or other recycled materials are defined. All waste material is likely to contain various constituents as well as concrete and brick. Crushed concrete is allowed to be used as sub-base material (Specification for Highway Works, 1986) but there should be some specific limits on contamination and a minimum limit on the amount of crushed concrete which should be

present.

Recently in Britain, several demolition contractors have purchased crushers and screens to recycle construction waste so that they might avoid high dumping costs and the difficulties of disposing of waste material. In general, these recycling plants are restricted to single crusher, on-site installations and usually consist of a jaw crusher working with sieves and sorting devices. This type of plant is capable of producing a crushed and graded material but is normally only used where there is sufficient debris to justify the expense of setting up the plant. The quality of the output normally depends on hand sorting and the electromagnetic removal of steel.

The recycled products from these mobile recycling operations are likely to vary considerably depending on the source of the rubble and the type of crushing and screening operation used. Some recycled products comply with existing standards for conventional aggregates but others do not. Material engineers and clients therefore do not have confidence in these materials because of the large variation in products from different operations. More respect for recycled materials could be instilled in engineers if sophisticated plant was used to produce less variable material and if a standard was written which included limits on contamination, to which demolition contractors would be forced to make their materials comply. This would be a significant step forward for recycling of demolition rubble in Britain.

Due to the increasing problem of fly-tipping on public and private streets in London and due to the high cost of dumping, the government within the last year has become more interested in recycling. The Aides to the Secretary of State for the Environment (1989) have said that the production of a standard for recycled materials is under consideration although financial support is lacking.

2.3.2 The Netherlands

The Netherlands has relatively poor reserves of natural aggregate and has become more dependent on recycled material for the construction of unbound aggregate road layers. Recycling in the Netherlands is mostly financed by the government and consequently recycled material has become an important source of aggregate for the Dutch construction industry.

Ten years ago, a number of roads constructed using unbound sub-base in the Netherlands had failed and there was some doubt concerning the empirical knowledge which existed then and whether the design of roads using this knowledge should be continued. A research project was started in 1983 as a joint venture between the Delft University of Technology and the Road and Hydraulic Engineering Division of Rijkswaterstaat in which the properties of recycled and conventional aggregates were examined. The research programme consisted of laboratory and field testing. It was found that visual inspection of the material composition was important because of the influence of particle strength and stiffness on the behaviour of unbound sub-base layers (Penning, 1989). Based on the results of this research project, which were described by Penning in 1989, an additional specification was issued by Centre Row (1988) for secondary materials which included crushed concrete, crushed masonry and demolition debris. Some of the main requirements in this specification (Centre Row, 1988) for crushed concrete and demolition debris are listed in Table 2.1.

When recycled material is to be used as aggregate for sub-base, it must pass the requirements listed in Table 2.1. It must also comply with the Dutch crushing test (similar to the ten per cent fines test) and the particle size distribution limits listed in the Dutch specification for conventional sub-base aggregate (Rijkswaterstaat, 1978).

MATERIAL TYPE	CRUSHED CONCRETE OR MATERIAL OF SIMILAR SPECIFIC GRAVITY	CRUSHED MASONRY	GYPSUM, PLASTIC, RUBBER, etc.	ASPHALT	ORGANIC MATTER SUCH AS WOOD OR PLANTS
Crushed concrete	not less than 90% by mass		not more than 1% by mass and by volume	not more than 5% by mass	not more than 0.1% by mass
Demolition debris	not less than 50% by mass	not more than 50% by mass	not more than 5% by mass		not more than 0.1% by mass

Table 2.1 Dutch specifications for recycled sub-base material (Centre Row, 1988).

Another standard, CUR (1986), has been developed in the Netherlands for the use of recycled material as aggregate in concrete. The specific gravity of the recycled aggregate should not be less than 2.1 and the material should contain at least 95% crushed concrete by mass. The remaining 5% of the material can be natural stone, lightweight concrete, ceramic material, brick or mortar with a minimum of 1% bituminous material by mass. The contamination of the aggregate should be determined by weighing or measuring the volume of the constituents contained in the > 8mm fraction. The amount of sulphate in the material should not exceed 1% and the amount of wood should be less than 0.5% by mass in the 0mm-4mm fraction and less than 0.1% in the fraction containing particles larger than 4mm.

CUR (1986) concluded that concrete made using recycled aggregate could achieve a strength equal to that of conventional aggregate concrete without the addition of extra cement, although in some cases some extra cement might be required. It also stated that the same durability could be attained, but deformation due to shrinkage and creep would normally be greater than for concrete made with natural aggregate. Therefore CUR (1986) suggested

that the depth of a concrete member should be increased by 10%, if 100% of the coarse aggregate used was recycled aggregate. If less than 20% of the coarse aggregate fraction was replaced by recycled aggregate, no increase in depth should be necessary.

It is likely that extra cement would need to be added to a concrete mix in which crushed masonry is used as the aggregate, if a similar strength to that of conventional aggregate concrete is to be achieved. The durability of concrete containing crushed masonry is likely to be similar to that of natural aggregate concrete but there may be a higher risk of frost attack (CUR, 1986).

2.3.3 Denmark

There is less incentive to recycle in Denmark than in Britain because natural aggregate is cheap and can be easily obtained (Jacobsen, Elle and Lauritzen, 1988). The disposal of waste material is inexpensive and is not restricted. Recycled material produced by Danish demolition contractors is considered to be unsuitable for many purposes because demolition and recycling operations are not properly designed to produce high quality material (Jacobsen, Elle and Lauritzen, 1988). However, a "recommendation for the use of recycled aggregates for concrete of passive environmental class" was produced by the Danish Concrete Association (1989). This recommendation suggested that the design and manufacture of recycled aggregate concrete would be similar to that used for conventional aggregate concrete but it stated that standard tests should be conducted more frequently because of the variation in the content of recycled aggregate.

In one research project conducted by Jacobsen, Elle and Lauritzen (1988), it was found when recycling was carried out, instead of the use of natural aggregate, that transport to and from a site was reduced by one third. The noise level due to crushing in the recycling operation

operation was higher than the average noise level, but there were no complaints from neighbours. Dust, on the crushing site, was gathered in a dust precipitator which was connected to the crusher and the stockpiles of recycled aggregate were sprinkled with water. Jacobsen, Elle and Lauritzen (1988) concluded that an expected output of 20,000 tonnes of material would be needed to warrant setting up a mobile recycling plant.

2.3.4 Belgium

Two major research projects into the recycling of construction waste have been conducted in Belgium. During the expansion of the port of Antwerp it was decided to construct a new lock (Morlion, Venstermans and Vyncke, 1988). The embankment walls of the old lock had to be demolished to provide better access. The demolition was carried out using explosives and yielded 80,000m³ of demolition waste. The quantity of new concrete which had to be cast was 650,000m³. Due to environmental and economic considerations, it was decided to recycle and reuse the demolition waste as aggregate for the new concrete (Morlion, Venstermans and Vyncke 1988). By performing cube tests on large lumps of the concrete produced from demolition and by using a Schmidt hammer it was found that the compressive strength of the old concrete was 30N/mm² with a standard deviation of 6N/mm². The 4mm-28mm fraction of crushed concrete was used as the coarse aggregate in the new concrete and a natural sand was used as the fines. The water/cement ratio was as low as possible so that shrinkage would be kept to a minimum and a cement content of 350kg/m³ was imposed in the project specifications. The outcome of this research project was favourable because the new concrete had a compressive strength of 35N/mm² and no deterioration has been reported (Morlion, Venstermans and Vyncke, 1988).

In another research project, crushed concrete was used in the construction of the basecourse and sub-base of seven test roads (Gorle and Saeys, 1988). The conclusions from this project were as follows:-

- (i) Some of the materials used were coarser than the specification required.
- (ii) The average density of crushed concrete was much lower than that of conventional aggregate.
- (iii) Using plate bearing tests immediately after construction it was found that the elastic modulus of the crushed concrete layer was lower than that of a layer constructed using conventional aggregate. However, after several weeks, the elastic modulus of the recycled aggregate layer had increased whereas no change was evident in the conventional aggregate layer.
- (iv) When recycled aggregate was used for these roads, 70% of the total cost saving was due to reduced transport. A 20% saving in cost was achieved due to the lower price of recycled material and a 10% saving was made because of the reduction in dumping costs.

2.3.5 Japan

In Japan, land is used very efficiently and to avoid having to provide many dumping sites, the Japanese have examined the possibility of recycling demolition waste for use as basecourse material in road construction. In 1976, a stationary recycling plant was set up in the suburbs of Nagoya city. As a result of the success of this recycling plant, a report called *The Technical Guide to Reuse of Waste for Pavements* was written by the Japan Road Association in 1984. At that time, the amount of demolition debris produced in Japan was estimated to be 10mt/year and the quantity of concrete rubble reused in roadbase construction

throughout the country was estimated to be about 100,000t/year. The amount of recycled material to be reused was expected to rise rapidly because the report written by the Japan Road Association (1984) was issued by the Ministry of Construction (Kasai, 1985).

The requirements listed in the report (Japan Road Association, 1984) are similar to those for conventional aggregate in Japan. The source of material for recycling which is preferred is concrete from road pavements because it is relatively clean. It has been found that the strength of a basecourse increases with time if it is constructed using crushed concrete (Yoshikane, 1988). Kawamura and Torii (1988) found that crushed concrete from an old pavement had better physical properties as an aggregate for concrete pavement construction than demolition debris.

A proposed standard for the use of recycled aggregate and recycled aggregate concrete was written by the Building Contractors Society of Japan in 1981. The Japanese continue to invest in research on recycling and recently a substantial amount of research has been conducted into the reuse of construction waste as aggregate for new concrete. Many projects have included an examination of the total replacement of conventional aggregate with recycled aggregate as the coarse fraction in new concrete. Yamato et al (1988), Ikeda et al (1988) and Fujii (1988) found that the compressive strength of concrete made with recycled aggregate as the total coarse aggregate fraction was 7%-20% less than that of conventional aggregate concrete.

Some interesting research projects in Japan have included the recycling of waste sludge from ready-mix concrete plants to produce cement (Yoda et al, 1988). This was performed by drying the sludge at 200⁰C. The recycled cement was then used to make concrete but the concrete had a lower workability than that of concrete made using OPC because the characteristics of the recycled cement were different. The compressive strength of concrete

made using recycled cement was half that of conventional concrete. It was suggested by Yoda et al (1988) that OPC should be added to recycled cement as an accelerator and that a low water/cement ratio should be used in concrete mixes made using recycled cement.

Kakizaki et al (1988) examined the possibility of using recycled aggregate as aggregate for structural concrete and found that the bonding strength between the concrete and reinforcement was 25%-40% lower than that in conventional structural concrete. The tests for this research were conducted on cubes of concrete containing steel bars. The coarse aggregate fraction in the concrete consisted totally of crushed concrete. Mukai and Kikuchi (1988) examined reinforced concrete beams made using a coarse aggregate fraction which consisted of 30% crushed concrete and 70% natural aggregate. The bonding and bending strengths were found to be similar to those of ordinary structural concrete. However, extra stirrups had to be added to the recycled aggregate beams so that the same shear strength could be attained.

2.3.6 Germany

After the 2nd World War, 11.5 million cubic metres of brick were recycled as aggregate for concrete in West Germany (Schulz, 1988). In 1951, a standard was introduced for concrete made with recycled aggregate but was withdrawn shortly afterwards and reproduced later as a standard for lightweight aggregates because the quantity of recycled aggregate available for recycling was decreasing. This standard in its current form is known as DIN 4226 (1983). At present, recycled aggregate cannot be reused for particular construction jobs without permission from the building authorities (Schulz, 1988). If permission is granted, the recycled material must conform to the Dutch standard, CUR (1986). DIN 4226 (1983) does not allow the inclusion of fine material in the aggregate because it considers that this fraction is likely to have the highest contamination level.

When recycled aggregate was used in the unbound layers of roads, Straube, Bechedahl and Gerlach (1989) found that deformation was higher than that observed in layers constructed using conventional aggregate. These results contradicted those of Sweere (1989) who found that the long-term stiffness of a compacted layer was improved if recycled aggregate was used. It was suggested by Straube, Bechedahl and Gerlach (1989) that when recycled aggregate is used, a factor of 2.5 should be applied to the layer thickness. It was concluded that recycled aggregate should only be used in the construction of lightly trafficked roads.

Recently in Germany, the dumping of construction waste was stopped in certain areas and consequently contractors are now forced to recycle waste material (Suss, 1989). However, the progress of recycling is impeded because there remains strong resistance to the use of recycled material due to the fear of high levels of contamination even though specifications for these materials have been drawn up (Suss, 1989).

2.3.7 United States of America

As a result of the increase in awareness that deposits of natural sand, gravel and stone have become depleted or exhausted in some areas or have become excessively expensive in the U.S., there has been a growing interest in waste concrete for reuse as aggregate in new construction (Mather, 1980). Marek (1972) recognised that the technical capability existed or could be developed for the manufacture of new supplementary aggregate materials and for the upgrade of poor quality aggregates. One of the conclusions of this report stated that research would be needed to characterise suitable aggregates before the use of recycled materials instead of conventional aggregates could be properly assessed.

Miller and Collins (1976) recommended that a strong central agency should be given the responsibility to coordinate research and development relating to waste material and to

provide encouragement for the acceptance of the resulting recycled products. It was also suggested that existing specification requirements for aggregates should be thoroughly reviewed and analysed with a view to the relaxation of certain stipulations, particularly in areas where shortages of conventional aggregates were likely to exist. It was concluded that consideration should be given to the adoption of performance specifications, even on a trial basis, to allow more latitude in the selection of highway materials. Britain at present appears to be facing the same difficulties which the U.S. encountered in 1976. Since these recommendations were made by Miller and Collins (1976), some state highway departments have developed their own specifications for recycled aggregate concrete pavements and in 1982, the specification for aggregate for concrete, ASTM C33-82, included crushed concrete in its definition of coarse aggregate.

The Edens Project: Show-case for Recycling (1980) summarised an operation involving the use of recycling for the repair of a fifteen mile stretch of major road on an interstate highway near Chicago. When the asphalt layer of the road had been removed, the badly deteriorated concrete underneath was broken up and crushed. Two materials were produced from the crusher output, a 25mm - 75mm rubble product which was later used as a porous granular backfill and a 0mm - 25mm capping material which was also used in the new construction.

Sadler (1973) reported on a recycling trial in Minnesota. Although the input to the recycling plant was a random mix of demolition waste, the recycled aggregate which was produced possessed a high degree of uniformity and was suitable for use as the base material in a road pavement. When the aggregate was compacted in a wet condition, the cement in the aggregate bonded the rough angular particles together. Recycled rubble was also used on a \$9.4 million project in California as sub-base aggregate (Crushing converts rubble into

sub-base aggregates, 1971). The recycled aggregate in this project performed well and its success was attributed to unhydrated cement in the concrete rubble which became a binder when the aggregate was mixed with water.

CHAPTER 3

STANDARD AGGREGATE TESTS

3.1 Introduction

Standard tests on recycled aggregates were conducted to provide a representative account of recycled products, currently on the market in Britain. British and Dutch recycled aggregates were compared with reference mainly to index testing to observe if similarities existed between the materials. As recycled aggregates are used extensively for sub-base layers in road construction in the Netherlands, it was thought if similarities did exist, then it would be a useful argument in persuading clients in Britain to opt for recycled aggregate products instead of conventional aggregates.

Although the Specification for Highway Works (1986) allows the use of crushed concrete, several demolition contractors have pointed out that there is resistance to its use even though it has been used successfully for many years. Demolition contractors tend to refer loosely to any aggregate produced from demolition rubble as crushed concrete. This could be clarified if a British specification existed which included definitions for both. In this research, the term crushed concrete refers to very clean crushed concrete produced from the break up and crushing of concrete slabs from road pavements. It is likely that this also is the definition which is inferred by the Specification for Highway Works (1986). Any material containing other constituents as well as crushed concrete e.g. brick, glass, asphalt, wood and block, is referred to as demolition debris. From the results of standard aggregate tests conducted during this research, it was apparent that demolition debris could perform as well as crushed concrete if it was used as sub-base material. Some demolition contractors believe that demolition debris would be too plastic due to its brick content. However, plasticity tests revealed that the recycled materials examined in this research were non-plastic.

3.2 Sub-base requirements

The recycled aggregates under review were tested mainly in accordance with the Specification for Highway Works (1986). In Clauses 803 and 804, the specification stipulates the requirements for Type 1 and Type 2 granular sub-base materials. All material intended for use within 450mm of a road surface is required not to be frost susceptible. The specification for Type 1 and Type 2 granular sub-base materials permits the use of crushed rock, crushed slag, crushed concrete and well-burnt non-plastic shale. Type 1 material is intended to withstand substantial trafficking by construction plant whereas Type 2 material can be used in less demanding circumstances and the specification therefore includes natural sands and gravels in this category. The grading envelope for Type 2 is wider than that for Type 1 to permit the use of material of lower maximum size and finer grading.

The quality of Type 1 material is governed by three laboratory tests, which include sieve analysis, plasticity and 10% fines tests. The fourth requirement is that the material should be transported, laid and compacted without drying out or segregation. For Type 2 material there is an extra condition specifying that the aggregate should not have a CBR (California Bearing Ratio) of less than 30%. This CBR requirement is assumed to be fulfilled automatically for Type 1 sub-base material.

The opportunity arose for part of the research to be carried out on site. A field trial was performed in Portsmouth to observe the differences between using Type 1 graded demolition debris and Type 1 limestone in the capping layer of two lengths of road. The demolition debris used in the Portsmouth field trial was specified as having a Type 1 grading and the limestone was a Type 1 certified sub-base material. It would have been more useful if the materials could have been placed as the sub-base of the road and monitored after completion but the client would not permit this.

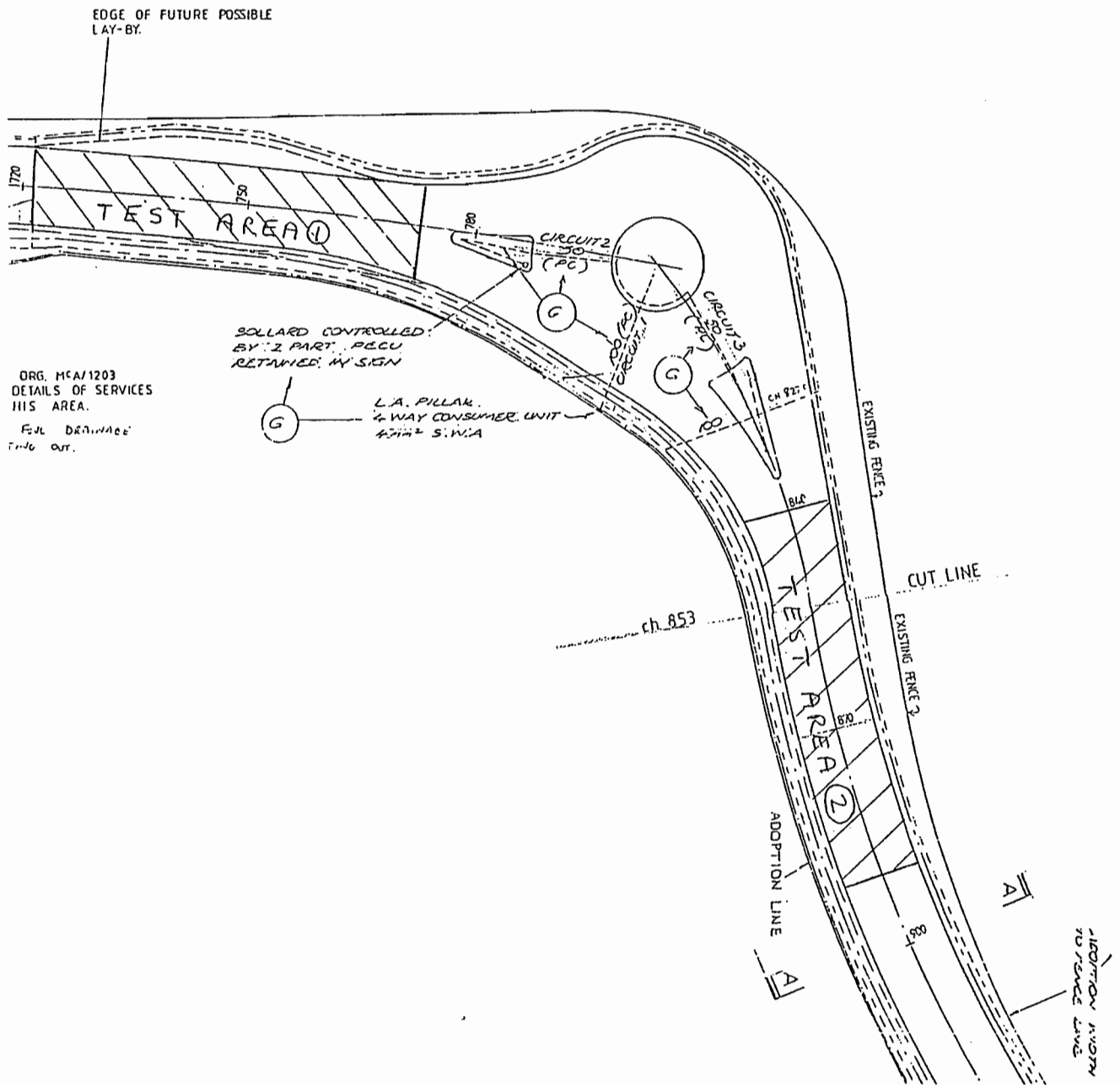

Figure 3.1 Plan of test areas in the Portsmouth field trial

The capping layer was divided in two for the field trial. The lower part was constructed using a coarsely graded, demolition debris capping material and the upper layer was used to compare the Type 1 graded demolition debris and Type 1 limestone. Two similar test areas were chosen on either side of a roundabout. Figure 3.1 shows the test areas on plan and Figure 3.2 outlines more specifically the test area details. The tests conducted for the trial were in situ density tests, sieve analyses and determination of the moisture content at which the aggregates were placed.

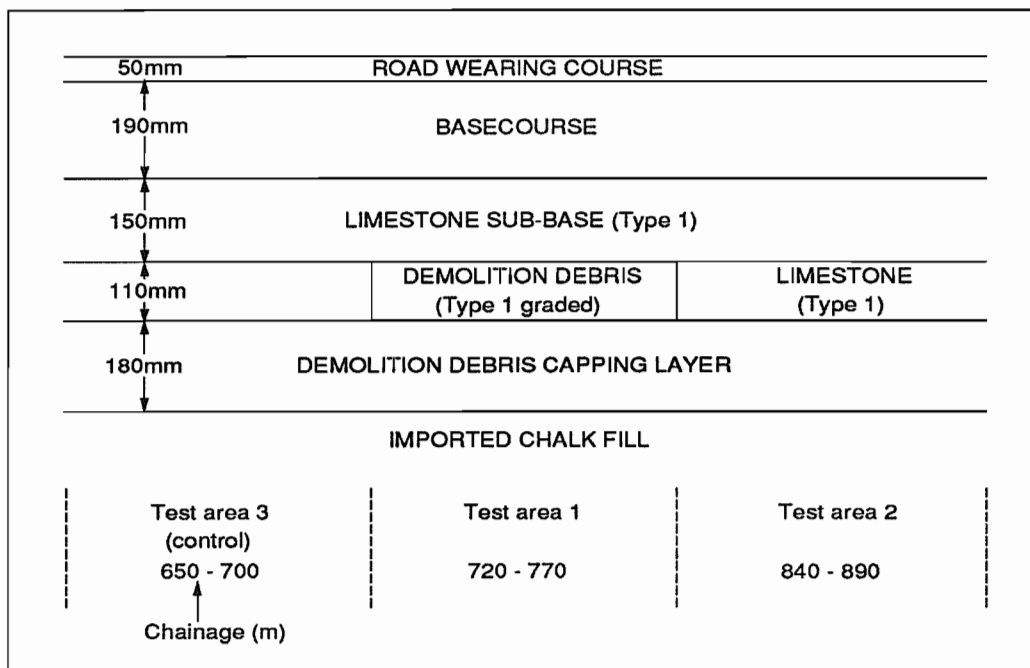

Figure 3.2 Composition of the test areas and the standard road

3.3 Particle grading

Sieve analysis of all material was carried out using the dry sieving method outlined in BS 812: part 102 (1985). The particle grading of an aggregate confirms whether the crusher setting and screening at a recycling plant is adequate to produce Type 1 and Type 2 gradings. Demolition debris, taken directly from the output of a single jaw crusher without screening,

was first examined. It can be seen from Figure 3.3 that there was considerable variation in the proportion of large particles in the samples which was caused by the change in the width of the gap between the crusher jaws. When a new set of jaws had been installed the crusher had a minimum setting of 65mm and a maximum setting of 100mm. However, as the jaws deteriorated on crushing, the settings measured a minimum of 90mm and a maximum of 128mm. Figure 3.3 shows that the aggregate could be considered for use as capping material although some of the samples were too coarse.

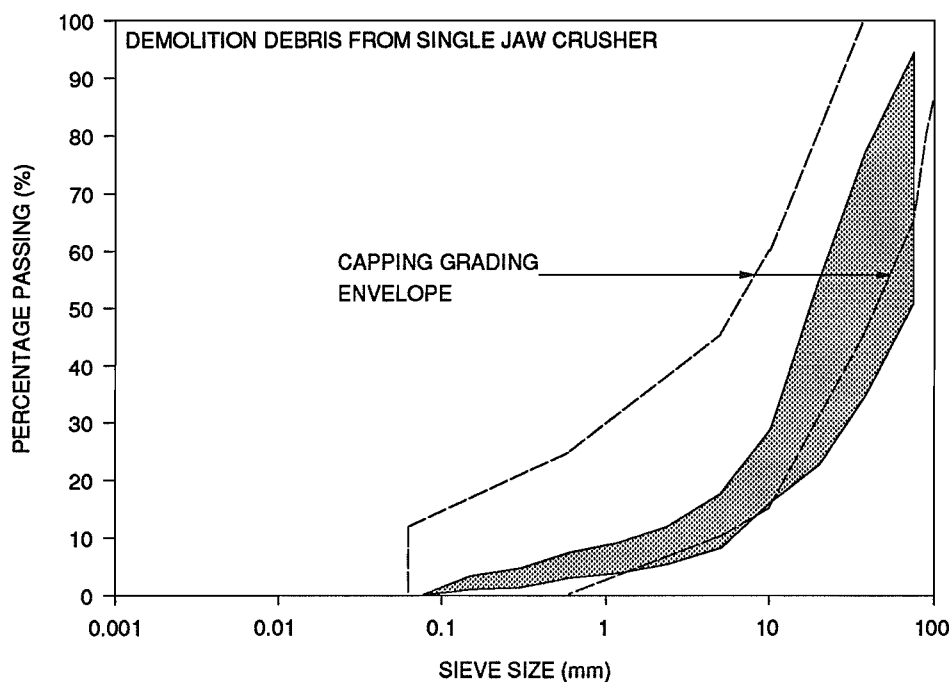

Figure 3.3 Direct output from jaw crusher

Type 2 graded material, produced from a single jaw crusher operation and simple sieving, was less coarse but its grading was close to the coarser end of the Type 2 grading envelope. In this case, the material was passed through 15mm, 10mm and 6mm screens according to Hughes and Salvidge Ltd. (1988). The volumes of aggregate allowed to pass the 6mm and 10mm screens were varied depending on the amount of fines required in the recycled product.

Demolition debris, produced from a double crusher operation consisting of a primary jaw crusher and a secondary impact crusher, was examined next. This material was screened to be a Type 1 grading but it can be seen in Figure 3.4 that although the particle grading was close to the specified grading envelope, it was too coarse for the most part. A Type 2 graded material, produced by the same operation, was much coarser and it can be seen in Figure 3.5 that the samples were consistently outside the limits.

In this recycling operation, run by Griffiths-McGee Demolition Co. Ltd. (1988), dirt, plaster and fines were removed by passing the material over a shaking screen. The aggregate was then deposited via a chute onto a conveyor to be transported to the jaw crusher. In this particular crushing operation the jaws were set to crush at 150mm-175mm. During crushing, most of the steel was dislodged from the rubble and removed by an electromagnet positioned over the conveyor belt which lead from the primary crusher. As the material was passed to the secondary crusher, aggregate which had already been crushed to the correct size was extracted and not processed further. The remainder of the material was passed to the secondary crusher where the jaw setting was 40mm-150mm. After secondary crushing the material was loaded for transportation or passed through a set of screens to achieve any grading of material required. It is clear from Figures 3.4 and 3.5 that the screening method used to obtain Type 1 and Type 2 gradings of demolition debris was not fully satisfactory. If recycled aggregates are to be used successfully in large quantities in the future, demolition contractors must be able to produce consistent gradings which are within the specification limits.

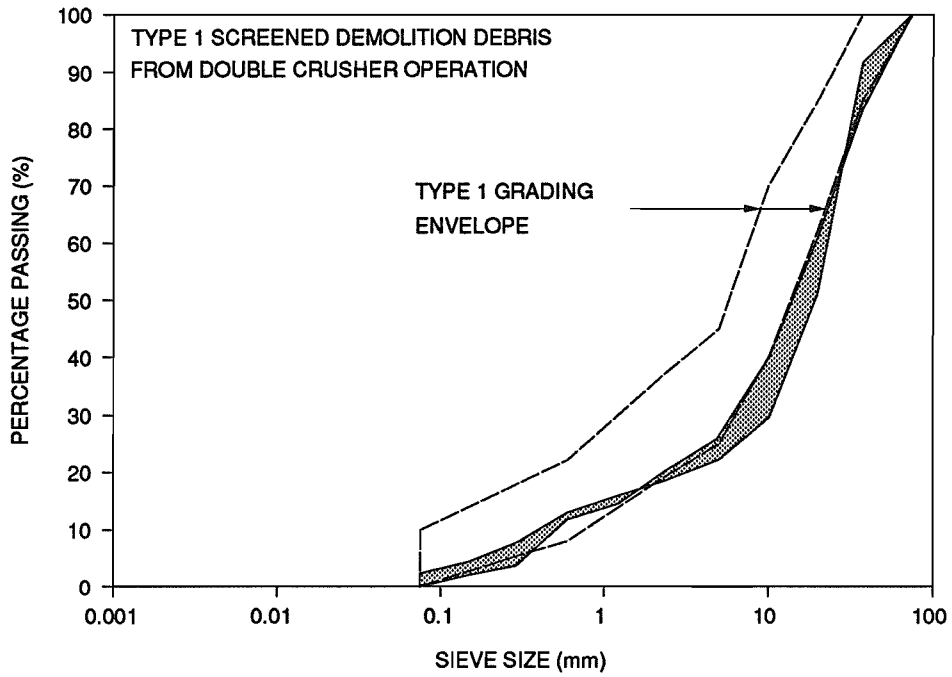

Figure 3.4 Type 1 screened demolition debris

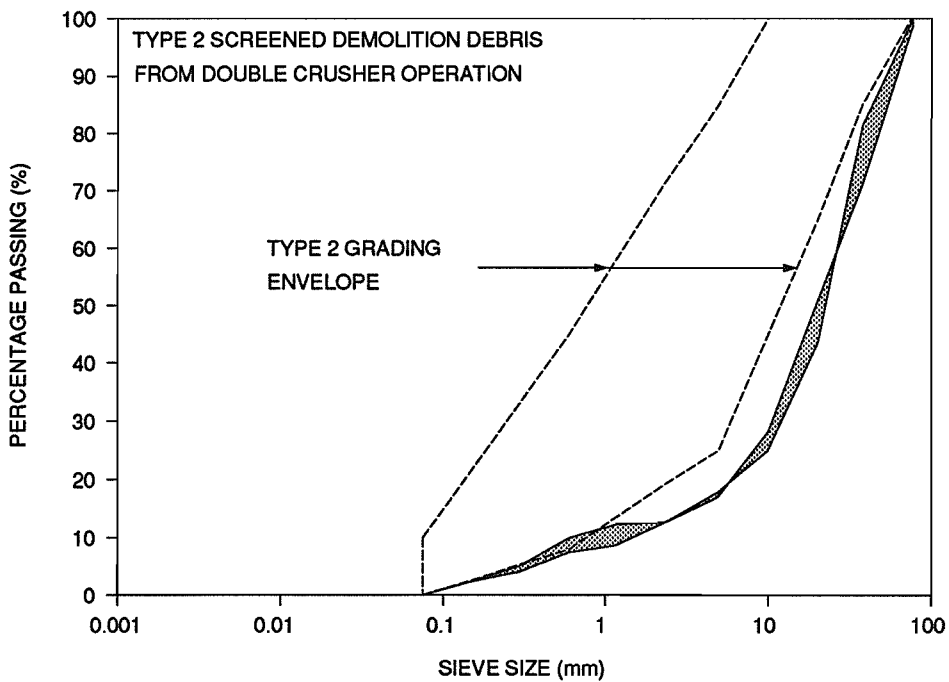

Figure 3.5 Type 2 screened demolition debris

The grading curves of Type 1 crushed concrete and Type 1 limestone are shown in Figure 3.6. The limestone, chosen as a conventional aggregate for use as a control in the sieve analysis tests, seemed slightly coarser than required and therefore fell outside the grading curve for the most part. The crushed concrete was produced by a single jaw crusher and had a better particle size range and an ideal Type 1 grading.

The particle grading of the demolition debris, used for the upper layer in the Portsmouth field trial, was generally within the Type 1 grading limits. This can be seen in Figure 3.7. The aggregate was processed in the same single crushing and sieving operation as the Type 2 graded demolition debris mentioned earlier (Hughes and Salvidge Ltd., 1988). However, variation of the amount of particles in the 6mm-10mm range changed the grading of the material to Type 1. The grading of this demolition debris compared favourably with the range of grading of limestone shown in Figure 3.8. In Figure 3.9, it can be seen that all demolition debris used in the lower layer in the Portsmouth field trial had a grading which was inside the capping material grading limits (Specification for Highway Works, 1986).

Type 1 and Type 2 graded material can be produced from both single and double crusher operations. However, the consistency of the grading depends on the crusher setting, wear and tear of the jaws and the screening process conducted after crushing. Some of the operations described earlier did not produce satisfactory gradings. It was also apparent that the production of limestone at a consistent Type 1 grading was difficult as limestone samples, tested for comparison purposes, had gradings which fell outside the Type 1 grading envelope.

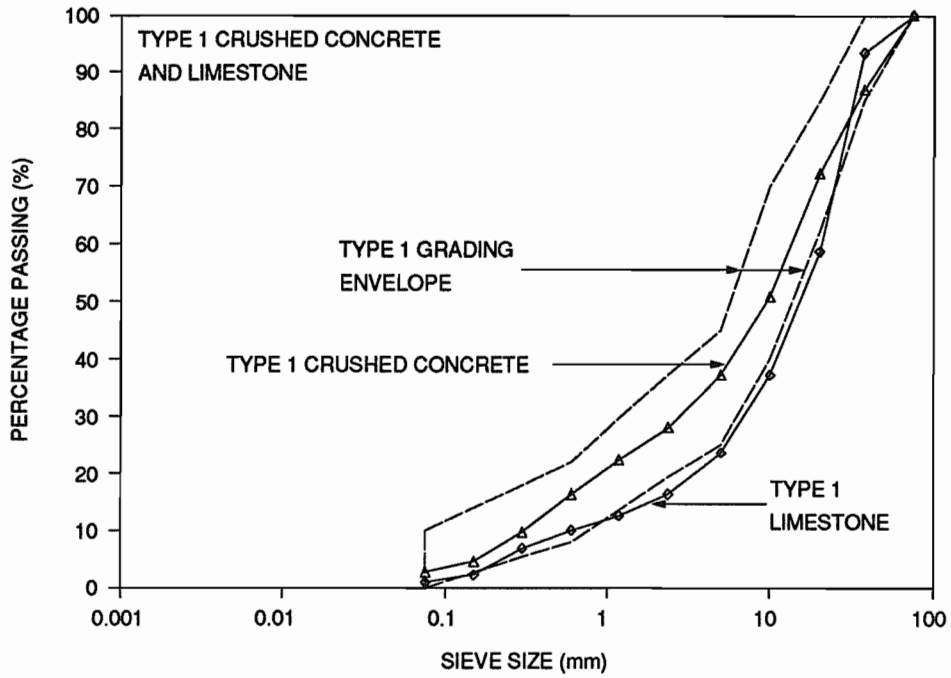

Figure 3.6 Type 1 limestone and crushed concrete

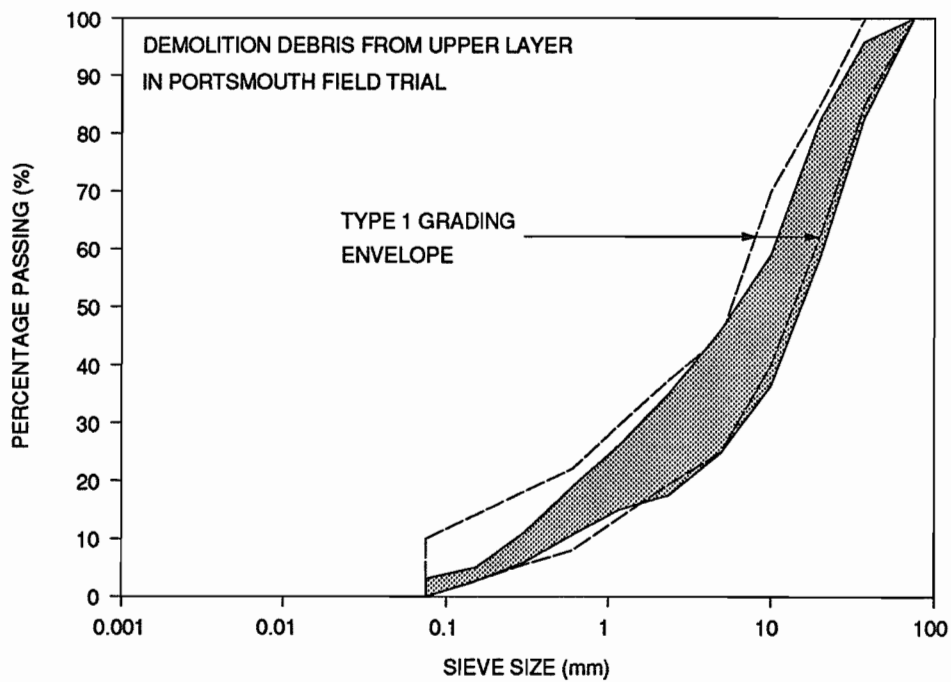

Figure 3.7 Demolition debris from the upper layer in the Portsmouth field trial

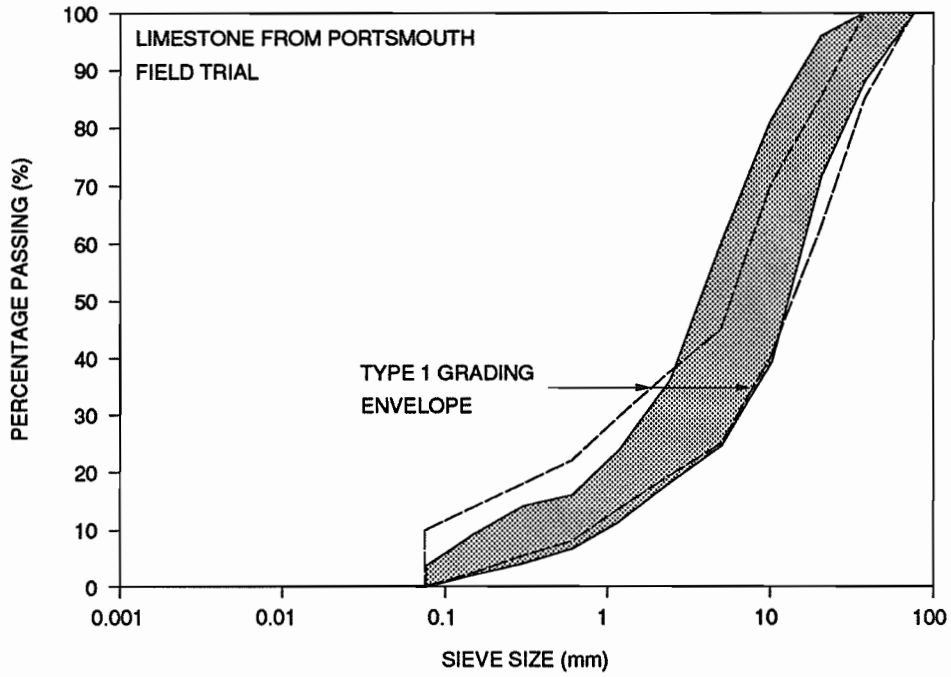

Figure 3.8 Limestone from the Portsmouth field trial

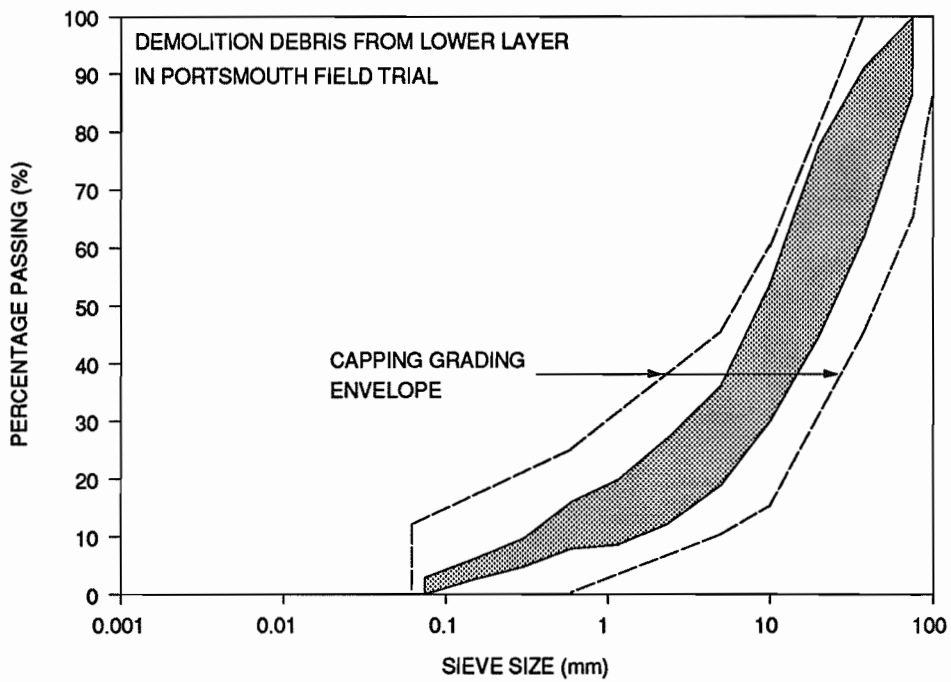

Figure 3.9 Demolition debris from the lower layer in the Portsmouth field trial

The particle gradings of crushed concrete, crushed masonry and a mixture of both from a Dutch double crusher operation were also examined. This recycling plant consisted of a primary jaw crusher and a secondary impact crusher and had better working conditions, a more organised layout and more scope for the production of a variety of recycled products than any plant in Britain at present. Both crushed brick and crushed rubble had gradings which were, for the most part, within the Type 1 grading envelope. This can be seen in Figure 3.10 where the particle grading of the Dutch brick falls almost centrally between the limits of the Type 1 grading envelope. The Dutch crushed concrete and crushed rubble did not comply with the Dutch specification grading limits (Rijkswaterstaat, 1978). This was surprising as the recycling plant was well equipped with screens and sorting equipment to combine various sizes of material to produce any grading required.

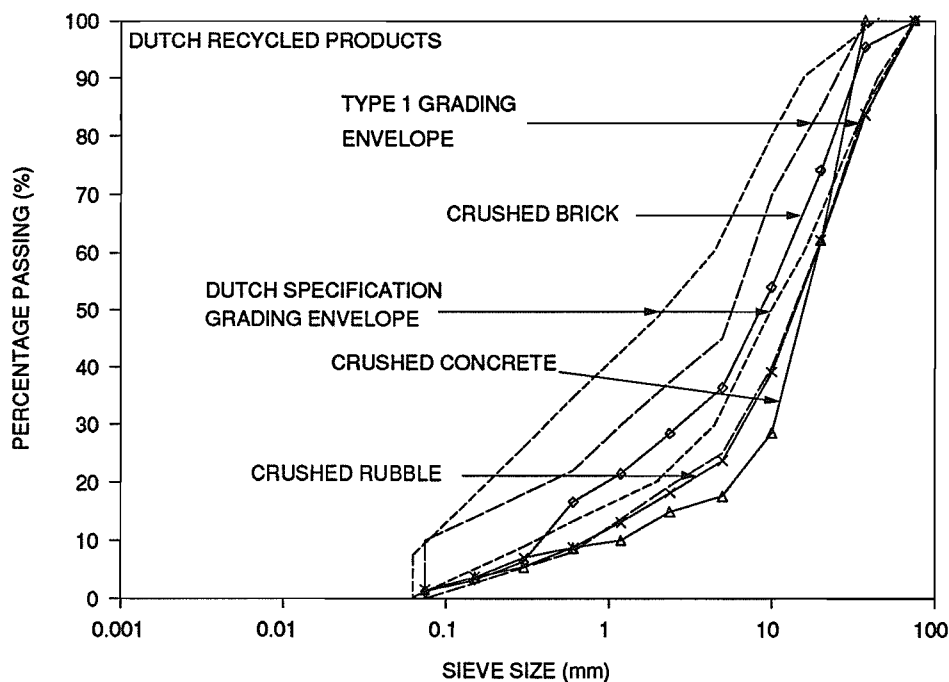

Figure 3.10 Dutch recycled products

3.4 Plasticity

According to the Specification for Highway Works (1986), aggregate to be used as Type 1 sub-base material should be non-plastic as defined by Test 3 of BS 1377 (1975) and Type 2 material should have a plasticity index of less than 6.

Demolition contractors express the view frequently that they assume recycled aggregate to be too plastic because of its brick content. All recycled aggregates tested during this research were found to be non-plastic, even a sample containing 11% brick. However, in comparison, a conventional limestone aggregate, certified as Type 1, had a plasticity index of 4. This material therefore should not be marketed as a Type 1 sub-base material. As the plasticity requirements for Type 2 sub-base material are less stringent, the limestone could be considered for use as a Type 2 material. It appears from the above results that, with respect to plasticity, recycled aggregate could be used as Type 1 or Type 2 sub-base material. The Dutch recycled products including crushed brick also proved to be non-plastic. There are no restrictions on plasticity in the Dutch specification, Rijkswaterstaat (1978). The samples of all recycled aggregates tested felt too gritty which suggested that the proportion of particles close to 0.425mm was quite large and the amount of clay sized particles present was too small to make the whole sample plastic.

The current Specification for Highway Works (1986) allows a maximum of 10% of a Type 1 sub-base material to pass the 0.075mm sieve, provided that the material passing the 0.425mm sieve is non-plastic. In previous editions of the specification, the fines passing the 0.075mm sieve were limited to a maximum of 2% although this percentage was permitted to rise to 10%, if the fines of this size were non-plastic. This relaxation, recommended by Dunn (1966), allowed the use of many crushed aggregates which prior to the relaxation had

been used successfully but did not meet the restrictions on plasticity. Dunn (1966) showed that maximum CBR values often occurred with a fines content of 4%-9%, even when the fines (<0.425mm) were plastic.

3.5 10% fines test

The 10% fines test was carried out in accordance with BS 812: part 3 (1975). The apparatus consisted of a cylinder with an internal diameter of 152mm into which a metal plunger of the same diameter fitted. The test was carried out using the following procedure which is detailed in BS 812: part 3 (1975). Aggregate in the 10mm-14mm fraction was added in thirds to the mould, each third being subjected to 25 strokes from a tamping rod. The plunger was placed on the aggregate so that it rested horizontally and the apparatus was placed between the plates of a compression testing machine. A force was applied to the plunger to cause a penetration of 20mm in about 10 minutes at as uniform a rate of penetration as possible. The maximum force achieved was noted and the percentage of the aggregate by mass passing the 2.36mm sieve after crushing was measured. The 10% fines value is the force required to produce 10% fines in the material and is calculated using the formula in BS 812: part 3 (1975) as follows:-

$$\text{The force required to produce } \frac{14(x)}{y+4} \text{ 10\% fines} \quad \dots \text{Eqn } 3.1$$

where x is the maximum force (kN) exerted on the plunger and
y is the mean percentage fines (<2.36mm) from two tests at x kN force.

It can be seen in Table 3.1 that British and Dutch crushed concrete had 10% fines values of 89% and 51% that of limestone respectively, but all materials tested had values greater than 50kN and therefore complied with the sub-base requirements listed in the Specification for

Highway Works (1986). The Dutch recycled products had 10% fines values similar to those of British demolition debris. The crushed masonry appeared to be the weakest material although at present it is the best selling recycled product in the Netherlands.

There is a crushing requirement listed in the Dutch specification, Rijkswaterstaat (1978), which is based on a test used only in the Netherlands but similar to the 10% fines test. This crushing test and particle grading limits form the Dutch specification requirements for sub-base materials (Rijkswaterstaat, 1978). There exists a separate specification for recycled aggregates, Centre Row (1988), which is mainly concerned with limiting the quantities of contaminants.

MATERIAL	TEN PER CENT FINES (kN)
Thames Valley gravel	175
Limestone	168
British crushed concrete	150
British Demolition debris	72-105
Dutch crushed concrete	85
Dutch crushed masonry	70
Dutch crushed rubble	75

Table 3.1 Ten per cent fines values

3.6 Specific gravity

The specific gravity (G_s) of the materials obtained in this research is that which Head (1980) defines as the apparent specific gravity. It is the specific gravity of the aggregates as they occur naturally and is the ratio between the mass of dry solids and the mass of distilled water displaced by the dry aggregate particles. The water absorption (W_a) of an aggregate is the moisture content at which the pores in the aggregate are full of water.

Specific gravity and water absorption tests, as described in BS 812: part 2 (1975), were conducted on the 40mm-5mm fraction and on material less than 5mm. The test method for each fraction was similar but 1kg of the large aggregate was tested in a glass bowl whereas a 1 litre pycnometer was used to test 500g of the finer material. The aggregate was washed thoroughly and immersed in water overnight before testing.

The larger material was placed in the bowl with water and any trapped air was removed by gentle agitation. The bowl was filled until it was overflowing and a glass plate was slid across the top taking care to trap no air bubbles. The bowl was dried and weighed (mass B). The vessel was emptied, refilled with water, dried and again weighed (mass C). The aggregate was spread on a dry cloth and allowed to dry in air until no films of water were apparent on its surface. It was then weighed in this saturated and surface dry condition (mass A). The aggregate was dried in an oven at 105^oC for 24 hours, cooled in an airtight container and again weighed (mass D).

The finer aggregate was placed in the pycnometer and water was added until it was level with the small hole in the lid. One finger was placed on the hole and the pycnometer was rolled on its side gently until air bubbles had accumulated in the water. The air was removed by placing the pycnometer upright and removing the finger from the hole. This procedure was conducted several times until all air was removed and the pycnometer was topped up again with water, dried and weighed (mass B). The remaining part of the test was conducted in a similar manner to that used on the large fraction but the finer material was dried using a warm current of air from a heater until it was in a free running condition. This state is defined in BS 812: part 2 (1975) as the condition in which no particles stick to the surface of a glass funnel, when some of the material is placed on its sloping surface.

Using the masses described above, the specific gravity can be calculated using the formula

$$G_s = \frac{D}{C - (B - D)} \quad \dots \text{Eqn } 3.2$$

and the formula for water absorption, expressed as a percentage, is

$$W_a = 100 \frac{(A - D)}{D} \quad \dots \text{Eqn } 3.3$$

Table 3.2 contains the range of results obtained from the specific gravity tests conducted on each material used in the Portsmouth field trial and the results for the materials which were used in the laboratory tests, described later in Chapters 4, 5 and 6, are also included. The water absorption values of the materials are also listed in Table 3.2.

MATERIAL	USE	SPECIFIC GRAVITY	WATER ABSORPTION (%)
Demolition debris	Upper layer in Portsmouth field trial	2.19-2.34	7.5-9.32
Limestone	Portsmouth field trial	2.55-2.67	0.5-1
Limestone	Laboratory testing	2.69	0.45
Demolition debris	Laboratory testing	2.56	8
Crushed concrete	Laboratory testing	2.58	3.76

Table 3.2 Specific gravity and water absorption of the aggregates

There appeared to be some difference between the specific gravity of the demolition debris used in the Portsmouth field trial and the demolition debris used for laboratory testing. This may be due to heavier constituents, such as stone, contained in the batch of material used for the laboratory tests. The water absorption of both batches of demolition debris was similar and it appeared to be quite high when compared with that of limestone. This was due to the porous nature of concrete and brick in the recycled aggregate.

3.7 Density tests on site

The locations at which density tests were conducted in the Portsmouth field trial are indicated in Figure 3.11 and reference should be made to Figure 3.1 for chainage positions. The lower capping layer of the road was first laid and compacted using a vibrating roller which had a mass per metre width of 3600kg. The upper capping layer was then placed and the compaction of this material can be seen in Plate 3.1. The method for measuring in situ density was based on the water replacement method for determining the density of rockfill or similar materials, which is described in Clause 27.8 of the Code of Practice for Site Investigations (BS 5930, 1981).



Plate 3.1 Compaction of the upper capping layer in the Portsmouth field trial

A 300mm diameter hole was dug to a depth equivalent to that of the top layer. The material was collected, stored in sealed bags and later weighed. The hole was lined with a polythene sheet and subsequently filled with water, the volume of which was known. Using the volume of water required to fill the hole and the mass of material collected, the dry density of the layer could be calculated. The same procedure was conducted on the lower layer. It is apparent from Figure 3.12 that demolition debris had a lower dry density than limestone, due mainly to its lower specific gravity, but the density of demolition debris was more consistent.

The dry density and moisture content of the aggregates used in the field trial are listed in Tables 3.3, 3.4 and 3.5. The demolition debris used in the upper layer had a dry density of 77% that of the limestone. This lower density was partly due to the difference in specific gravity of the materials. The demolition debris had a specific gravity of 2.19-2.34 which was 82%-92% that of the limestone.

To examine the particle packing of the materials, the results are best compared in terms of the proportion of volume occupied by solids (V_s) which is defined in BS 5835 (1980) (the compactibility test for graded aggregates) as

$$V_s = \frac{\rho_d}{10G_s} \quad \dots Eqn \quad 3.4$$

where ρ_d is the dry density expressed in kg/m^3 and

G_s is the specific gravity.

It can be seen in Table 3.4 that the demolition debris in the upper layer filled 79.9% of the volume on average whereas 90.3% of the volume of the limestone layer was filled with limestone particles (Table 3.5). Therefore the limestone particles were packed more closely together than those of demolition debris.

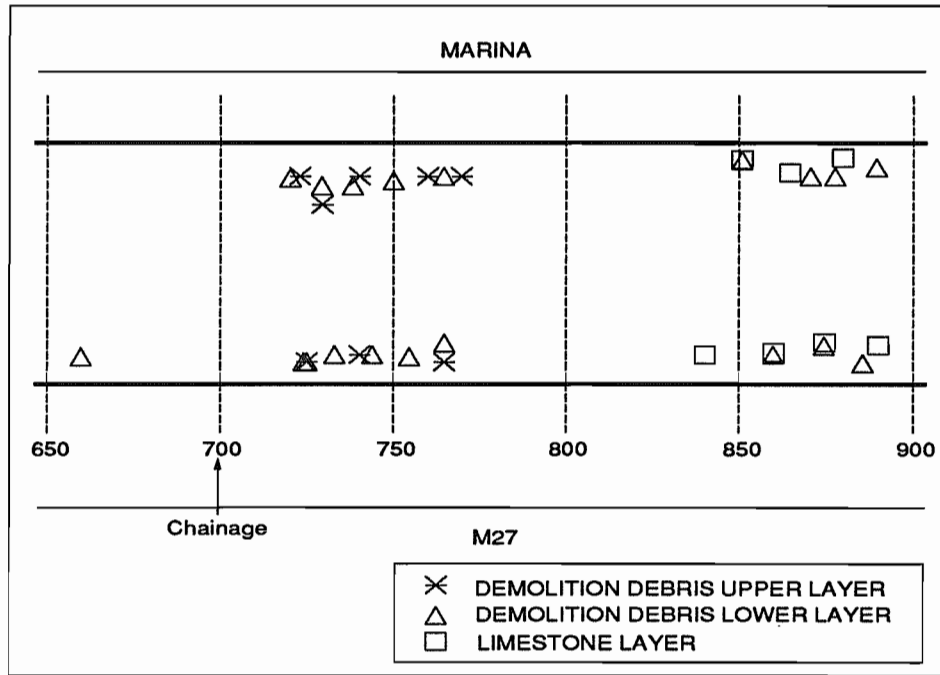

Figure 3.11 Locations of in situ density tests

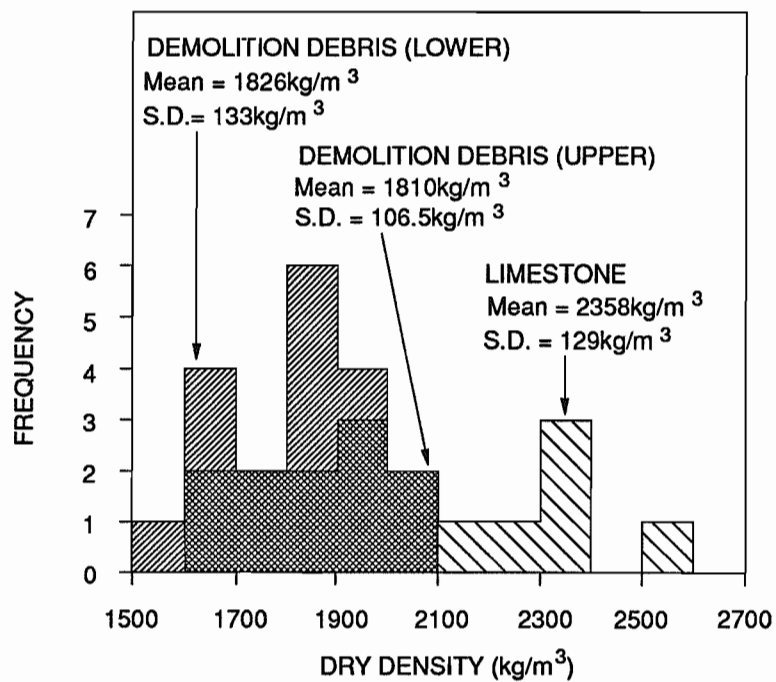

Figure 3.12 Dry densities of Portsmouth field trial materials

DEMOLITION DEBRIS LOWER LAYER					
LOCATION	CHAINAGE (m)	DRY DENSITY (kg/m ³)	V _s (%)	MOISTURE CONTENT (%)	FREE WATER CONTENT (%)
M27 SIDE	660	1850	81.7	8.2	-0.21
	725	1632	72	5.5	-2.91
	734	1908	84.2	9.3	0.89
	745	1886	83.3	5.7	-2.71
	755	1938	85.6	6	-2.41
	765	1583	69.9	5.5	-2.91
	726	1809	79.9	9.2	0.79
	860	1890	83.4	6.9	-1.51
	886	1636	72.3	8.2	-0.21
	875	1889	83.4	3.7	-4.71
MARINA SIDE	721	1861	82.2	9	0.59
	739	1927	85.1	8.5	0.09
	765	1739	76.8	7.5	-0.91
	730	1774	78.3	8.4	-0.01
	750	1694	74.8	8.6	-0.19
	851	2058	90.9	6.2	-2.21
	871	2041	90.1	5.7	-2.71
	878	1667	73.6	8	-0.41
890	1914	84.5	5.5	-2.91	
AVERAGE		1826	80.6	7.14	-1.27
STANDARD DEVIATION		133	5.88	1.58	1.578

Table 3.3 Conditions of the demolition debris lower layer in the Portsmouth field trial

Note: M27 side and marina side refer to the location of the test positions on the road (see Figure 3.11)

The limestone was placed at a moisture content of 0.96%-4.1% whereas the demolition debris used in the upper layer had a moisture content of 8.5%-13.3% compared with 3.7%-9.3% in the lower layer. It can be seen in Tables 3.3, 3.4 and 3.5 that the deviation from the average moisture content was between 1% and 1.6% for the three materials. The free water content of the samples was compared i.e. the effect of water absorption was removed. Free water is the active part of the moisture content during compaction. Limestone was found to have

a free water content of 0.06%-3.6% compared with 0.09%-4.89% for the demolition debris upper layer. Therefore the free water contents of limestone and demolition debris were quite similar.

A negative value of free water content means that the material was placed at a moisture content lower than its water absorption value. It can be seen from Table 3.3 that demolition debris in the lower layer was placed in relatively dry conditions. In Chapter 4, the peak dry density and optimum moisture content for limestone obtained in the laboratory are found to be 2320kg/m³ and 3.5%. It is clear from Table 3.5 that generally a higher density was obtained on site than in the laboratory at a moisture content lower than the laboratory optimum which suggests that site compaction was more effective than compaction in the laboratory. A comparison is made between in situ and laboratory density in Chapter 8.

DEMOLITION DEBRIS UPPER LAYER					
LOCATION	CHAINAGE (m)	DRY DENSITY (kg/m ³)	V _s (%)	MOISTURE CONTENT (%)	FREE WATER CONTENT (%)
M27 SIDE	726	1721	76	13.3	4.89
	740	1919	84.7	8.5	0.09
	765	1606	70.9	11.7	3.29
MARINA SIDE	722	1842	81.3	9	0.59
	730	1739	76.8	10.3	1.89
	740	1817	80.2	12	3.59
	760	1900	83.9	11	2.59
	770	1933	85.3	9.5	1.09
AVERAGE		1810	79.9	10.66	2.25
STANDARD DEVIATION		106.5	4.69	1.535	1.53

Table 3.4 Conditions of the demolition debris upper layer in the Portsmouth field trial

LIMESTONE LAYER					
LOCATION	CHAINAGE (m)	DRY DENSITY (kg/m ³)	V _s (%)	MOISTURE CONTENT (%)	FREE WATER CONTENT (%)
M27 SIDE	840	2520	96.5	1.6	1.1
	860	2139	81.95	1.9	1.4
	875	2394	91.72	1.4	0.9
	890	2355	90.23	0.96	0.06
MARINA SIDE	851	2234	85.6	3.2	2.7
	865	2519	96.5	4.1	3.6
	880	2344	89.8	1.6	1.1
AVERAGE		2358	90.3	2.1	1.55
STANDARD DEVIATION		129	4.94	1.04	1.1

Table 3.5 Conditions of the limestone layer in the Portsmouth field trial

3.8 Impurities

Kasai (1985) suggested that particles of demolition debris larger than 8mm should be examined for impurities by visual inspection and weighing. When the demolition debris used in this study was examined, the amount of brick and block present was found to be 17.5% by mass whereas the gypsum content was 2.7%. Steel and wood were also present in quantities of 1.2% and 0.25% by mass respectively. The volume of wood contained in the material was 2.5% assuming that the wood had a specific gravity of 0.5. This was below the suggested maximum level of 4% quoted by the Building Contractors Society of Japan (1981) but was higher than the maximum level of 0.1% by mass quoted in the Dutch specification, Centre Row (1988). It is likely therefore that recycling operations in Britain will need to employ aquamators, similar to those in operation in the Netherlands, to ensure low levels of lightweight impurities.

3.9 Discussion

While conducting the standard tests on the aggregates, it appeared that limestone was just as likely not to comply with the sub-base requirements in the Specification for Highway Works (1986) as recycled aggregate. When recycled aggregate is to be used for a particular purpose, the client usually requires that it undergo the full series of compliance tests. However, when a conventional aggregate such as limestone is to be used, the only limits to which it must conform are those for particle grading. It is suggested that all aggregates be tested in a similar manner because it was found that the Type 1 certified limestone, examined in this research, did not comply with the Type 1 requirements for grading and plasticity.

The plasticity test (BS 1377, 1975) is a test which is very operator dependent and the reproduction of results is difficult, particularly at low values of plasticity. Due to the problems associated with this test, some scope should be included in the Specification for Highway Works (1986) for the variation in plasticity results which are likely to exist in practice. Alternatively, another test should be considered which would take into account the effect on plasticity of large particles in the aggregate. It was agreed at the Symposium on Unbound Aggregates in Roads (1989) that the plasticity test described in BS 1377 (1975) was satisfactory for the testing of soils but it was suggested that a new test should be devised for testing aggregates. Highway engineers would like to see more standard tests conducted on aggregate on site rather than in the laboratory, due to the difficulty of calibrating laboratory tests with site conditions.

3.10 Conclusions

- (i) It appears to be difficult to obtain consistent gradings of both conventional and recycled aggregates. The wear and tear on the crusher jaws is probably the main cause of the variations in grading of the recycled materials.

- (ii) All recycled materials tested were non-plastic unlike a Type 1 certified limestone which had a plasticity index of 4. Some consideration should be given to the development of a new test for the determination of the plasticity of aggregates.
- (iii) The specific gravity of limestone was 2.69 compared with 2.58 and 2.56 for crushed concrete and demolition debris respectively. The water absorption values were 0.45% for limestone, 8% for demolition debris and 3.76% for crushed concrete. The high value for demolition debris was attributed to the porosity of the mortar and brick in the material.
- (iv) The quantity of wood present in the demolition debris was less than the maximum contaminant level suggested by the Building Contractors Society of Japan (1981) but higher than the maximum level stipulated in the Dutch specification (Centre Row, 1988).
- (v) It appears that site compaction is more effective than compaction in the laboratory. This comparison is discussed more fully in Chapter 8.
- (vi) Both natural and secondary aggregates should be made to undergo the same series of compliance tests because it was found that a Type 1 certified limestone did not conform to some of the sub-base requirements. It is likely that the use of recycled aggregates in construction would increase if a fair testing system existed.

CHAPTER 4

COMPACTION AND CALIFORNIA BEARING RATIO TESTS

4.1 Compaction

4.1.1 Introduction

When aggregate is used as road sub-base material or fill, one of the most important influences on its behaviour is density. Deformation, shear strength, frost susceptibility and permeability are greatly influenced by the density at which the material is first placed and generally a high density improves the performance of a sub-base or fill. Increasing the density of a granular material is achieved by compaction which involves reducing the air voids, without reducing the moisture content (Head, 1980). Air voids cannot be eliminated altogether by compaction but they can generally be reduced to 5%. This is necessary so that ingress of water after compaction is reduced. When many air voids exist in a material after compaction, swelling may occur if the moisture content increases after placement (Cobbe and Threadgold, 1988). Hill (1985) agrees that obtaining minimum air voids at the time of placement may be satisfactory but states that compacted aggregates are sensitive to moisture change and voids soon become filled with water which does not drain away easily.

The requirement in the Specification for Highway Works (1986) for compaction of a Type 1 sub-base material is that the material should be compacted without drying out or segregation. If an aggregate is to be used as a Type 2 sub-base material, it should be compacted at a moisture content within the range 1% above to 2% below the optimum moisture content. This moisture content is determined by conducting the compactibility test for aggregates, described in BS 5835 (1980), on the material.

The two factors which have the greatest effect on density are moisture content and the compactive effort exerted on the material. To examine the effect of moisture content, a series of tests is normally conducted using a standardised test i.e. with a constant compactive effort, for a range of moisture content.

As the moisture content of a fine grained soil is increased, the dry density (ρ_d) also increases until it reaches a point of peak density ($\rho_{d,peak}$). The moisture content at which this occurs is termed the optimum moisture content (OMC). When the OMC has been reached and the moisture content is increased further, the excess water begins to push the particles apart so that ρ_d is reduced (Head, 1980). Cohesionless soils do not respond to variations in moisture content in the same manner as fine grained soils. A peak density is reached but on the dry side of OMC the curve is quite flat, particularly for well graded materials, and it is not uncommon for a second peak to be recorded at a low moisture content (Lee, White and Ingles, 1983). The two peaks on the dry density/moisture content curve are normally separated by a point of low density. Lambe and Whitman (1979) concluded that this point of low density, obtained at a low moisture content, is due to capillary forces resisting rearrangement of the particles.

Lambe and Whitman (1979) noted that the term dry density is usually used as another expression for dry unit weight. They are, however, not equal because density is actually $1/g$ times unit weight where g is the gravitational constant.

4.1.2 Compaction apparatus and test procedures

Compaction tests were carried out on limestone and demolition debris following the procedure of the compactibility test for aggregates, detailed in BS 5835 (1980), using the apparatus designed for this test in the Pavement Materials and Construction Division of the Transport and Road Research Laboratory. Pike and Acott (1975) designed the test because

the vibrating hammer method, described as Test 14 in BS 1377 (1975), which is normally used for compaction tests on granular soils, could not produce the compactive effort required to reproduce the density of aggregate likely to be obtained in the field. Compaction on site has become more effective. The BS 5835 (1980) test involves compacting aggregate in a mould with a vibrating hammer hung from a frame under a standard surcharge. Pike and Acott (1975) found that this test method was capable of producing densities similar to those obtained in the field and as the test was not dependent on the operator, the results were more repeatable than for compaction tests used previously.

Samples of aggregate at a range of moisture content were tested using the following procedure, which is covered in detail by BS 5835 (1980), to determine the relationship between moisture content and dry density. All particles larger than 37.5mm were removed and the aggregates were oven-dried. Each material was then divided into portions of between 2.4kg and 2.6kg. Three of these portions were mixed at each target moisture content and left to stand overnight in sealed containers.

The 150mm diameter mould, in which the portions were compacted, is illustrated in Figure 4.1. The depth of a compacted sample was approximately 70mm. The mould was connected to a base plate which contained recesses to allow for the collection of excess water expelled from the sample during compaction. At the bottom of the mould there was a filter assembly, which is also shown in Figure 4.1, consisting of two perforated plates and filter fibre to allow drainage of water from the samples. The anvil (see Figure 4.1), which was placed on the aggregate before compaction, fitted the mould snugly and had a rounded protrusion on its upper face on which the hammer tool was placed during compaction. In the centre of this protrusion was a small hole for locating the depth gauge when measuring the height of a sample.

To obtain accurate results, it was necessary to measure precisely the height of the sample after compaction. Before the aggregate was placed in the mould, the distance between the bottom of the mould and its top was measured using the following procedure (BS 5835, 1980). Two filter papers were placed in the bottom of the mould and the anvil was inserted. The vibrating hammer was applied to the anvil for 5 seconds and the distance between the hole in the anvil and the top of the mould was measured to 0.1mm. The apparatus was dismantled three times and this procedure was repeated. The average of the three depth readings was calculated and this average was considered to be the datum. The mould was reassembled and one filter paper was placed at the bottom.

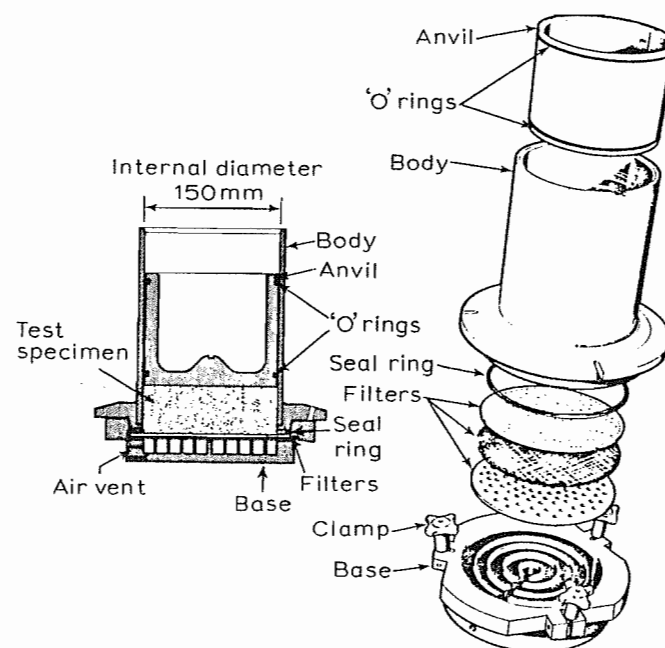

Figure 4.1 Mould and anvil for the compactibility test (after Head, 1980)

One of the portions of aggregate was placed in the mould and roughly levelled. A filter paper was placed on top of the sample followed by the anvil. The whole mould assembly

was placed under the loading frame inside a noise reducing cabinet (Plate 4.1). The hammer tool was placed on the anvil followed by the vibrating hammer whose top was connected to the loading frame. The surcharge weight required to produce a steady downward force of 400N on the sample was hung from the end of the lever arm of the frame, as illustrated in Plate 4.1. The door of the noise reducing cabinet was closed and the vibrating hammer was operated for 180 seconds. After compaction, the mould assembly was removed from the frame taking care not to disturb the anvil and the distance between the anvil and the top of the mould was measured to an accuracy of 0.1mm. The height of the sample was found by subtracting the depth reading after compaction from the datum. The aggregate was extracted from the mould, weighed and dried at 105⁰C until it reached constant mass. The dry density was calculated by dividing the mass of dried aggregate by the volume of the sample. The calculation of moisture content was the same as that used in Test 1 of BS 1377 (1975). The whole process was repeated on the remaining portions. BS 5835 (1980) stated that the results at one moisture content should be averaged but in this work the results from all tests were plotted to form the dry density/moisture content relationship for each material.

The main disadvantage of the test is that the size of the mould limits the maximum size of particle to be tested to 37.5mm although the Specification for Highway Works (1986) allows 15% of particles in an aggregate for use as road sub-base to be larger than 37.5mm.

When the limestone and crushed concrete aggregates were obtained from the suppliers they contained very few particles larger than 37.5mm. However, about 10% of the demolition debris particles were too large to be tested by the BS 5835 (1980) test. This suggested that the compaction test might not simulate the compaction of demolition debris in the field due to the difference in particle grading. To investigate whether the density would change if the grading was altered, the following apparatus and test were devised.

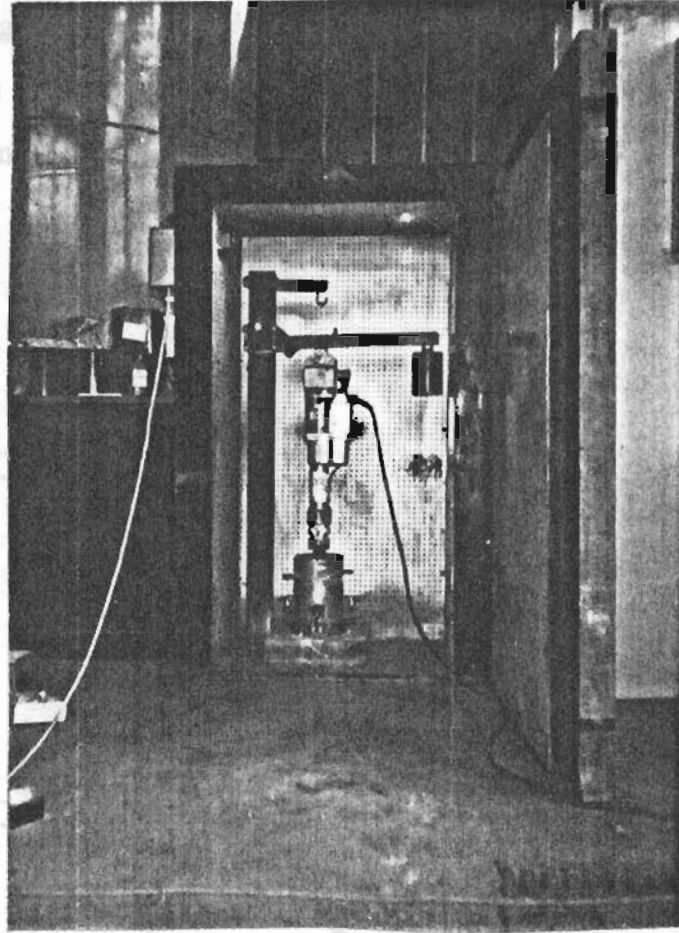

Plate 4.1 BS 5835 (1980) compaction test apparatus located at TRRL

A steel mould of 300mm internal diameter was used with 5mm diameter holes drilled in its end to allow excess water to drain away during compaction. A 3.2mm thick layer of filter fibre, known as Vyon, sandwiched between two perforated plates was used as the filter assembly and was positioned at the bottom of the mould supported on a 20 mm thick spiral spacer so that excess water could drain from the samples. The mould assembly and plate are shown in Figure 4.2. The filter assembly was temporarily sealed to the edge of the mould using silicon sealant. Two filter papers were placed on the upper filter plate and the

steel plate (see Figure 4.2) was placed on top. The distance between the plate and the top of the mould was measured at twelve positions around the perimeter of the mould. The average of these measurements was used as a datum.

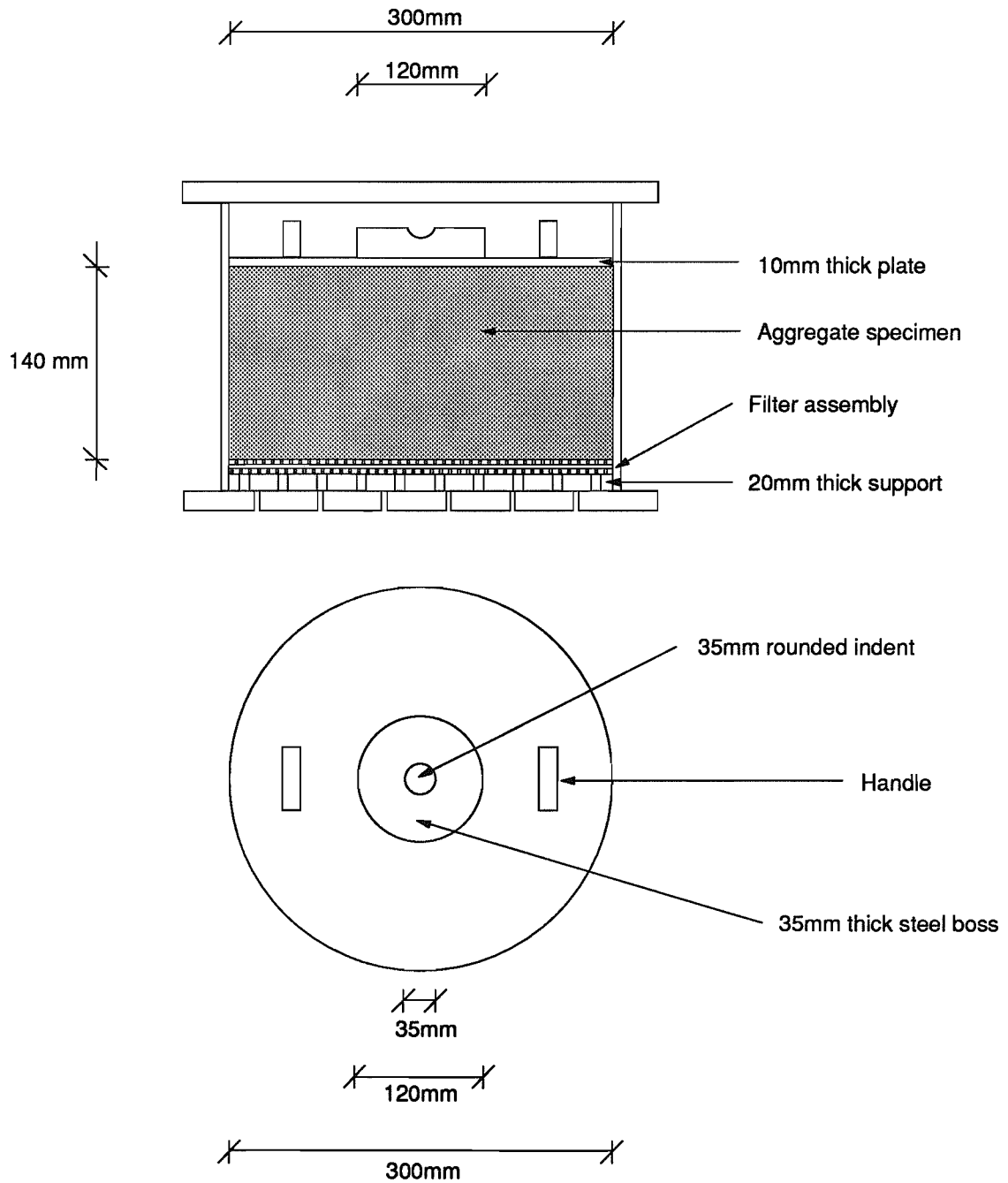

Figure 4.2 300mm diameter compaction mould and plate for large apparatus

The maximum particle size which was tested in this apparatus was 75mm. It was considered that the height of a sample to be compacted in the 300mm diameter mould should be 140mm to maintain the same maximum particle size/height of sample ratio which was used in the BS 5835 test (1980). The volume of a sample in the large mould was eight times larger than that in the BS 5835 (1980) apparatus and therefore 20kg of material was required for each test.

During construction of the apparatus, a large steel boss of 120mm in diameter and of thickness 25mm was welded to the upper surface of a 10mm thick plate (see Figure 4.2). A rounded indent was made in the centre of the boss into which a modified vibrating hammer tool fitted. Originally the tool had been connected by a weld to the plate but this was not very satisfactory due to the following reason. The vibrating hammer was hand held during compaction and it was difficult to keep the hammer central at all times. Consequently, the welded joint snapped due to bending stresses and the vibrations produced by the hammer. It was decided therefore to allow the tool free movement within the indentation and this proved to be a better arrangement.

One of the tools supplied with the vibrating hammer was modified for the compaction tests. The shaped end of the tool was cut off and the raw edge was rounded so that it would fit in the indentation in the boss. After a few tests had been completed it was found that the end of the tool had mushroomed quite badly. Generally tools for vibrating hammers are heat treated during manufacture to harden the surface but not the inner steel. Therefore when the tool was cut the softer steel was exposed and consequently was damaged by the stress placed on the hammer. To prevent further deterioration of the tool, advice on heat treatment was sought from the supplier of the vibrating hammer (Kango Tools Ltd., 1989) and following this advice the tool was heated in a furnace to 800⁰C for five minutes and then cooled rapidly in water to harden the steel. It was then heated again to 260⁰C and cooled in air to remove

some of the brittleness caused by the first stage of heat treatment. After this procedure had been conducted, deterioration of the tool during testing was slower but the tool was not fully protected against damage and had to be reshaped at intervals during the test series.

All samples of aggregate were mixed at the target moisture contents on the day before test to ensure uniformity of the moisture content throughout the sample. In the BS 5835 test (1980), the whole portion of aggregate was added to the mould and compacted in one layer. However, the only hammer on the market which was considered suitable for the purpose of compaction in the large apparatus was the same hammer as that used in the BS 5835 test (1980) but it did not have the capacity to compact 20kg of material in one layer. Therefore the 20kg sample of aggregate was divided into three and one of these portions was placed in the mould on a filter paper and another filter paper was placed on top followed by the metal plate.

The tool was inserted and clamped in the vibrating hammer which was hand held during the three minute vibration time allotted to each layer in the compaction tests. The vibration time was decided upon after a series of trial tests. Increasing the compaction time per layer beyond three minutes did not change the density but a compaction time less than this was insufficient to produce a sample of constant volume. After compaction the hammer and tool were removed and depth readings from the top of the mould to the top of the plate were taken. The sample and mould were weighed so that the density could be calculated. The material was removed from the mould and weighed. A sample of 5kg was dried at 105°C for 24 hours and weighed to determine the moisture content. From the depth measurements, the mass of wet material and the moisture content, the bulk density (ρ_b , defined as the mass of wet material divided by the volume of the sample) and the dry density (ρ_d) could be calculated using the same method as described in the BS 5835 test (1980).

4.1.3 Results

Both compaction test methods were conducted on samples of limestone and demolition debris containing particles smaller than 37.5mm, to assess the ability of the large apparatus to reproduce the densities obtained using the BS 5835 test (1980). The results for limestone are shown in Figure 4.3 where the curves for both test methods appear to be similar except at a moisture content of 0% where the samples in the large apparatus achieved higher densities. This difference in density was caused by the friction forces which developed between the dry aggregate and the sides of the mould. These forces were likely to have greater influence in the smaller mould making the samples more difficult to compact. When moisture was added to the aggregate, the friction forces were overcome more easily and consequently the densities obtained in both apparatus at moisture contents greater than 1% were similar. Some difference existed between the optimum moisture contents achieved in the two tests where the OMC achieved in the BS 5835 test (1980) was 3.5% and that attained in the large test was 4.5%.

The results for demolition debris are shown in Figure 4.4 along with results of tests conducted in the large apparatus on demolition debris containing particles larger than 37.5mm. At low moisture contents the effect of friction on the sides of the moulds is again evident. There appears to be little difference in the results for the two gradings of demolition debris. It can be concluded therefore that the removal of particles greater than 37.5mm did not affect the density of the aggregate significantly.

Compaction tests were conducted on crushed concrete in the large apparatus and as this test produced similar densities to those obtained in the BS 5835 test (1980) for limestone and demolition debris, it was decided that testing in the large apparatus would be adequate for

the determination of the dry density/moisture content relationship of crushed concrete. The results for crushed concrete are shown in Figure 4.5 where the relationship can be seen to be quite well defined.

In Figures 4.3, 4.4 and 4.5, the 0%, 5% and 10% air voids lines were plotted using the specific gravity values of 2.69, 2.56 and 2.58 for limestone, demolition debris and crushed concrete respectively which were listed in Chapter 3. It can be seen in Figures 4.4 and 4.5 that some of the densities obtained in the compaction tests corresponded with 0% air voids and in a few cases fell to the right of the 0% air voids line. Head (1980) stated that it is impossible for this to happen but there are two likely reasons why it occurred in these tests.

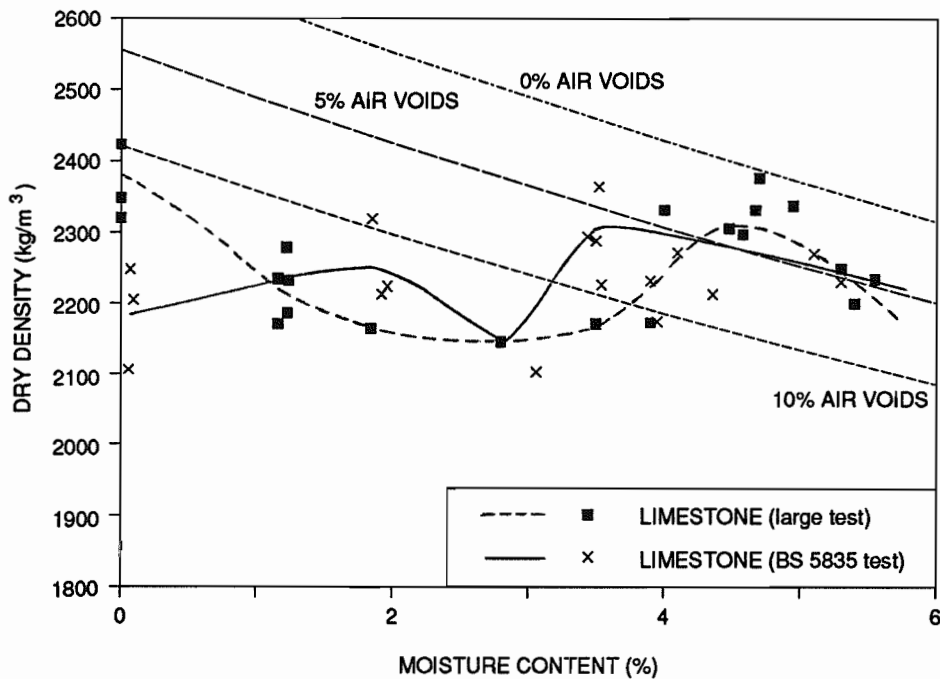

Figure 4.3 Relationship between moisture content and dry density for limestone

The curves in Figures 4.3 and 4.5 cannot be justified by the data alone but have been drawn in a tentative manner in light of previous knowledge quoted by Lee, Wight and Ingles (1983). This also applies to Figure 4.10 which is presented later.

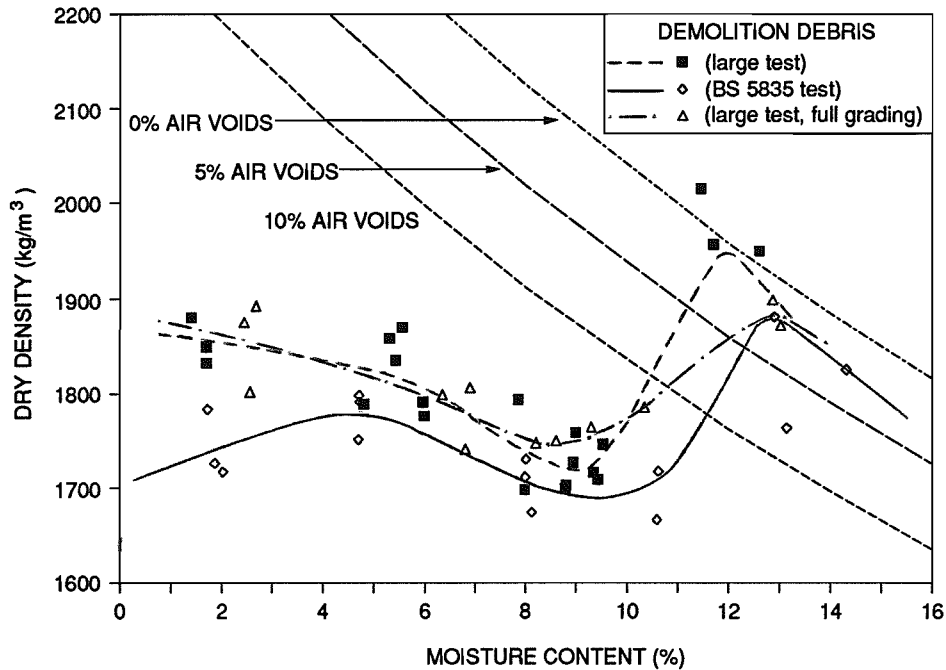

Figure 4.4 Relationship between moisture content and dry density for demolition debris

First, the measurements of specific gravity may not have been accurate due to the variation in content of the recycled materials and secondly, the measurement of moisture content may not have been exact. The tests used to determine specific gravity were carried out several times because there appeared to be variations in the results, particularly for demolition debris which contained assorted materials. These materials would also have had various water absorption values. In a demolition debris sample the constituents would not have been dispersed equally throughout the material. Therefore one sample of aggregate when dried could be found to have had a higher moisture content if a large proportion of the material had the ability to absorb a large quantity of water.

To examine the amount of crushing caused by compaction, particle grading tests on the aggregates were conducted before and after the compaction tests and the results are shown in Figure 4.6 for limestone, Figure 4.7 for demolition debris of particle size less than 37.5mm, Figure 4.8 for demolition debris, as obtained from site, and in Figure 4.9 for crushed concrete.

It can be seen that little crushing of limestone particles occurred but some crushing of demolition debris and crushed concrete particles was evident and may have contributed to the high densities in the dry density/moisture content relationships. The OMC and $\rho_{d,peak}$ obtained from the compaction tests are listed in Table 4.1 for all materials.

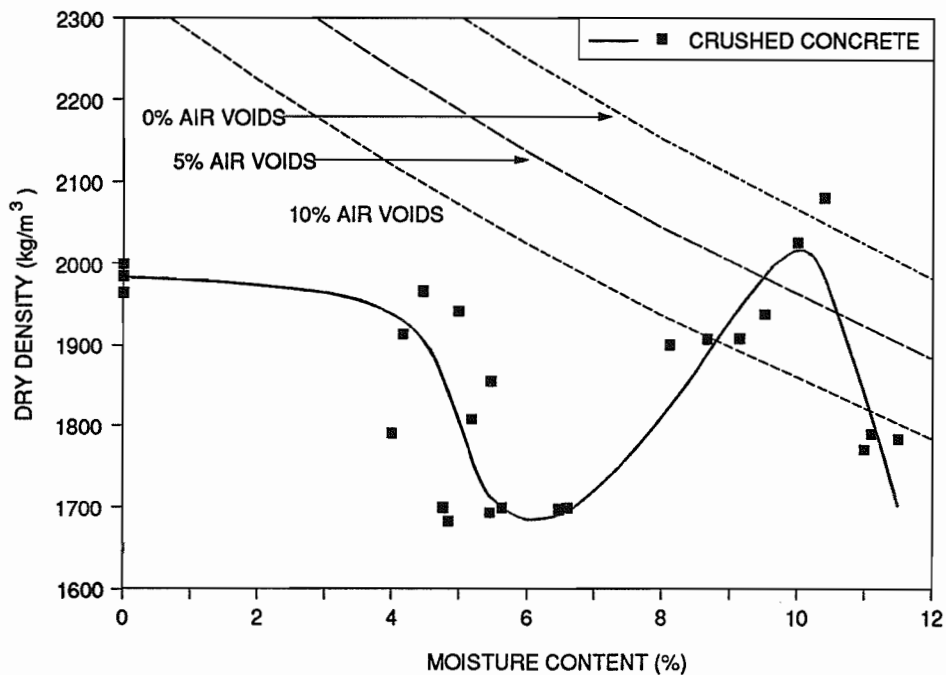

Figure 4.5 Relationship between moisture content and dry density for crushed concrete

By comparing the results in Table 4.1 for the two test methods, it can be seen that both series of tests on limestone gave similar results but the series on demolition debris (< 37.5mm), conducted in the large apparatus, produced a relatively high $\rho_{d,peak}$. This density value, however, corresponded to 0% air voids and might not have been representative due to variations in the specific gravity of demolition debris and moisture content measurement. It can be seen in Table 4.1 that the free water available at peak density for the three materials was in the range 3% - 5.5%. Free water is the part of the moisture content which plays an active part in compaction and for the three materials appeared to be quite similar.

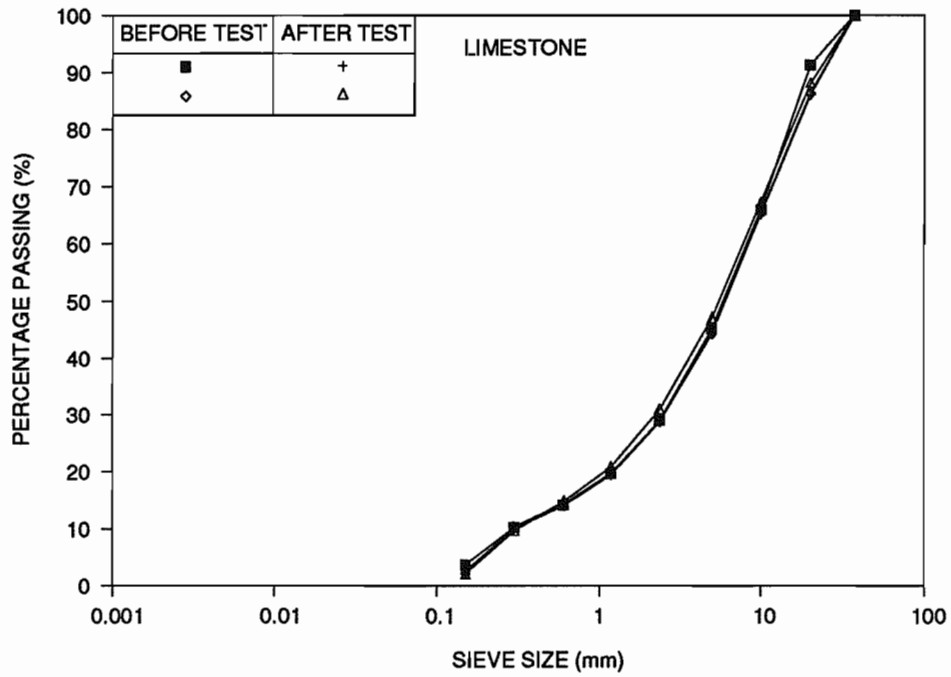

Figure 4.6 Particle gradings of limestone

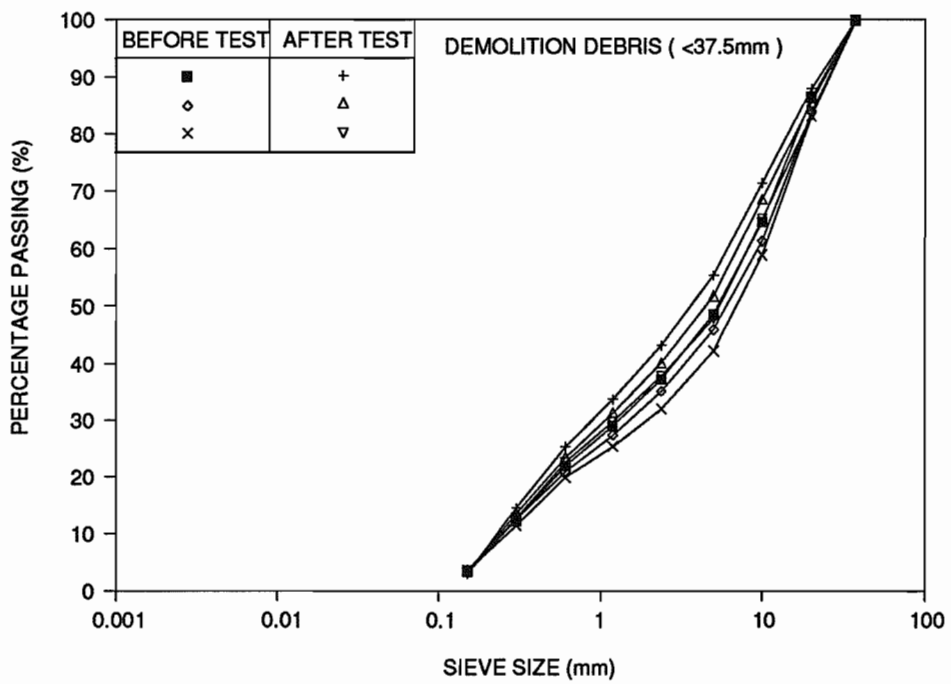

Figure 4.7 Particle gradings of demolition debris (<37.5mm)

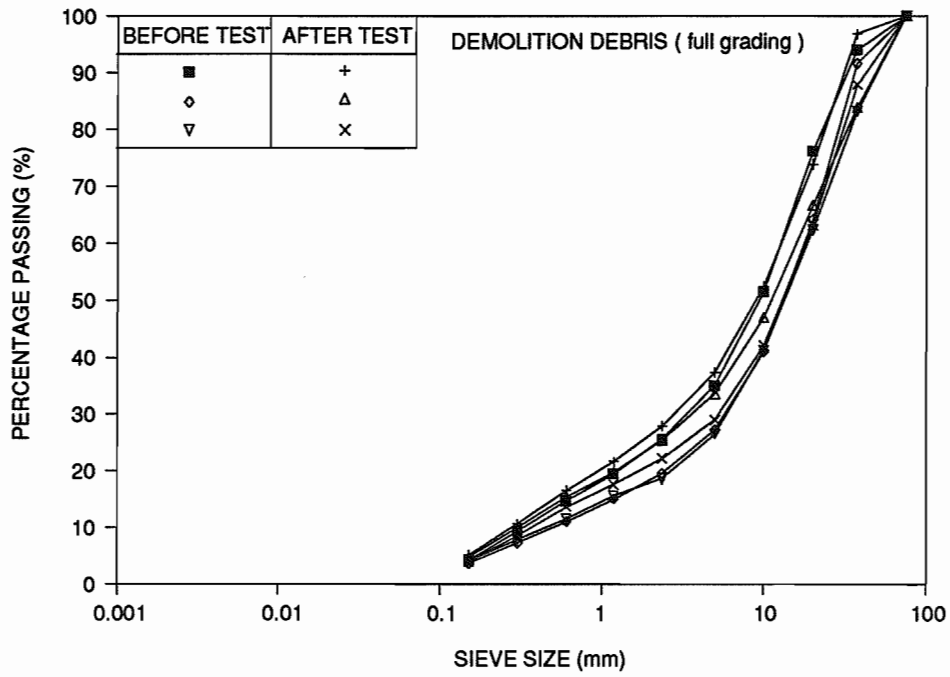

Figure 4.8 Particle gradings of demolition debris (full grading)

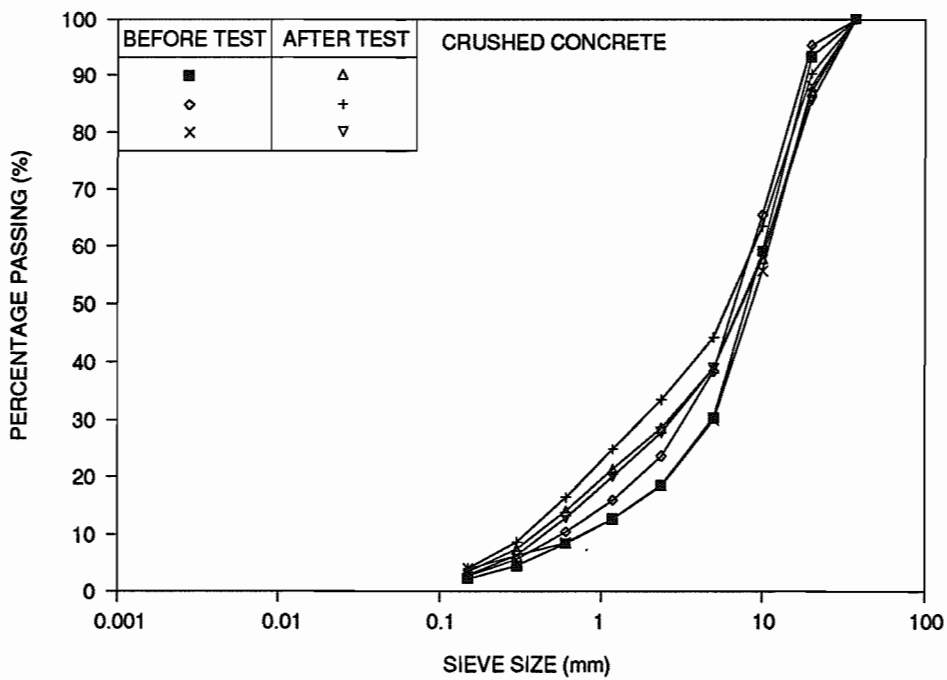

Figure 4.9 Particle gradings of crushed concrete

MATERIAL TYPE	TEST TYPE		OMC (%)	FREE WATER (%)	$\rho_{d,peak}$ (kg/m ³)
	LARGE TEST	(BS 5835) TEST			
LIMESTONE		X	3.5	3.1	2320
LIMESTONE	X		4.5	4.1	2320
DEMOLITION DEBRIS		X	13	5	1880
DEMOLITION DEBRIS	X		12	4	1950
DEMOLITION DEBRIS (full grading)	X		12	4	1880
CRUSHED CONCRETE	X		10	5.3	2000

Table 4.1 OMC and $\rho_{d,peak}$ results for all materials

BS 5835 (1980) suggests a method for the expression of compaction results in volumetric terms. This is useful for the comparison of materials with different values of water absorption and specific gravity. Density is expressed in another form known as the proportion of volume occupied by solids which was defined in Eqn 3.4. Moisture content can be expressed as the proportion of volume occupied by free water which is defined as

$$V_{fw} = \frac{\rho_d(MC - W_a)}{1000} \quad \dots Eqn \ 4.1$$

where ρ_d is the dry density (kg/m³),
 MC is the moisture content (%) and
 W_a is the water absorption (%).

These formulae for V_s and V_{fw} , listed in BS 5835 (1980), can be derived from the basic definitions of soil mechanics (Bowles, 1984). This alternative method of presenting results allows the packing of particles in the samples to be examined. It can be seen in Figure 4.10 that demolition debris and crushed concrete have similar relationships and therefore their particles can be assumed to pack in a similar manner. This may be due to similar surface texture and angularity. The maximum V_s obtained for demolition debris and crushed concrete was 73.5% and 78% respectively. Limestone achieved a higher V_s of 87% which means that the packing of limestone particles was more effective.

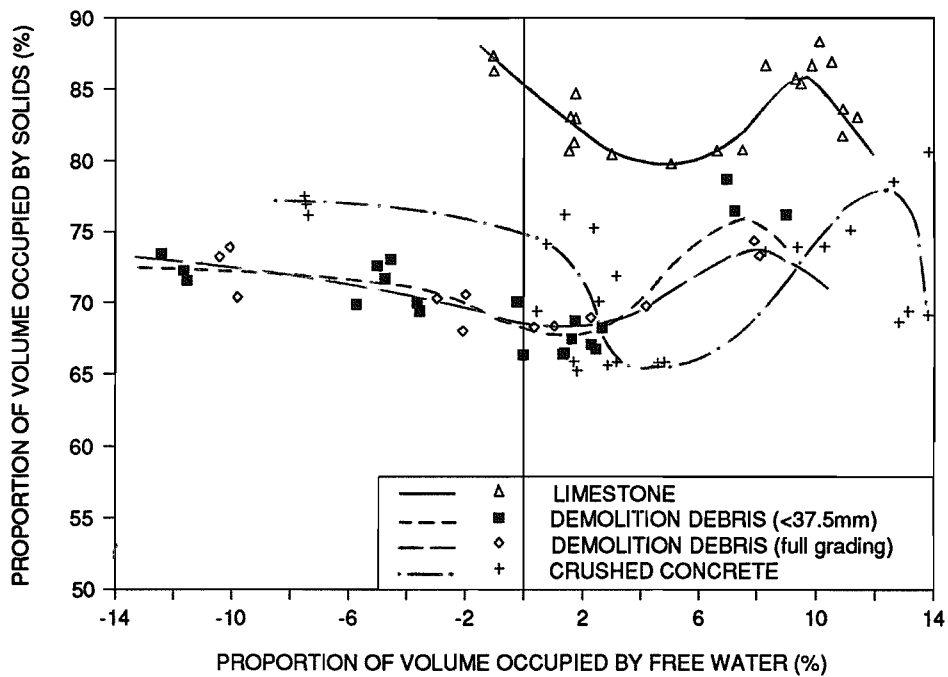

Figure 4.10 Results of compaction tests expressed in volumetric terms

4.2 California Bearing Ratio

4.2.1 Introduction

The California Bearing Ratio test or the CBR test, as it is commonly called, is a penetration test which estimates the bearing capacity of sub-bases and subgrades. Much doubt exists about the relevance of the test and its usefulness because of the difficulty in producing a sample in a 152mm diameter mould at the same conditions expected in the field. Engineers would prefer to use a site test such as the plate bearing test or the Clegg impact soil tester so that the full grading of aggregate could be tested in actual site conditions. The CBR test and the plate bearing test exert stresses on the aggregate statically although generally road pavements are loaded dynamically (Hill, 1985). Another disadvantage of the plate bearing test is that not only is it influenced by the stiffness of the sub-base layer but also by the stiffness of the layers below (Sweere and Galjaard, 1989).

The Clegg impact soil tester consists of an accelerometer attached to a 4.5kg drop hammer of the type used for compaction tests on soils. The hammer is dropped on to the material and the reading of peak deceleration is recorded as the Clegg impact value (CIV). This test involves loading the material dynamically but a disadvantage of the test is that CIV, expressed in units of gravitational acceleration, cannot be used directly for pavement design.

Each of the three tests therefore has disadvantages and this highlights the difficulty of designing a test which reproduces the effects of traffic loading and yields results which can be used directly for pavement design. Trafficking trials are the best method of determining the ability of sub-base material to withstand traffic loading. Unfortunately, however, trials in most cases would be considered too expensive and time consuming.

The Specification for Highway Works (1986) does not include CBR requirements in Clause 803 for Type 1 road sub-base material because the aggregates allowed for use in this category are assumed automatically to achieve high CBR values. CBR requirements are listed for Type 2 materials because of the inclusion of natural sands and gravels in this category. If traffic loading is to be more than 2 million standard axles (msa), the CBR of Type 2 material should not be less than 30%. For traffic loading less than 2 msa, a minimum CBR of 20% is required. However, if more than 10% of the material is retained on a 20mm sieve, the material as a whole can be assumed without test to have a CBR of 30% or more. The conditions at which CBR tests should be conducted are OMC and the density relating to an air voids content of 5% (Specification for Highway Works, 1986).

Although more than 10% of each of the recycled materials tested in this research was retained on a 20mm sieve, CBR tests were conducted on demolition debris and crushed concrete and the results were compared with those of a Type 1 limestone to investigate the bearing capacity of recycled materials. Some tests were carried out at OMC and $\rho_{d,peak}$ but the CBR of the aggregates was also examined at the same range of moisture content and dry density conditions which were obtained from the compaction tests listed in Section 4.1.3.

4.2.2 The CBR test

Test 16 of BS 1377 (1975) describes the CBR test which involves pushing a standard 50mm diameter plunger into a compacted material at a fixed rate of penetration. Particles greater than 20mm in size were removed from the aggregates, as required by BS 1377 (1975), and samples of each material were mixed at a range of moisture contents. The 152mm diameter mould was attached to the base plate and a filter paper was placed at the bottom. The mass of material needed to obtain the required density for each test was weighed and placed in the mould under continual tamping with a 20mm diameter rod. A filter paper was placed on top of the material followed by a metal plug.

BS 1377 (1975) lists compaction procedures including static and vibratory methods and any of these can be used to compact aggregate in a CBR mould provided that the method is noted in the results. A method of static compaction using a compression testing machine was used in this research. It would have been more consistent to use the same compaction method as that used in the compaction tests (Section 4.1.2) but the BS 5835 (1980) apparatus was located at TRRL. The mould and plug were placed centrally in the compression testing machine and the aggregate was loaded until the height of the sample was reduced to 127mm. The load was held constant for one minute so that rebound would not occur.

This method of compaction for the CBR tests was very severe and crushing of particles could be heard when the materials were under compression. The particle gradings of the samples, before and after compaction and penetration, were examined. It can be seen in Figures 4.11, 4.12 and 4.13 that limestone and demolition debris had better resistance to crushing than crushed concrete.

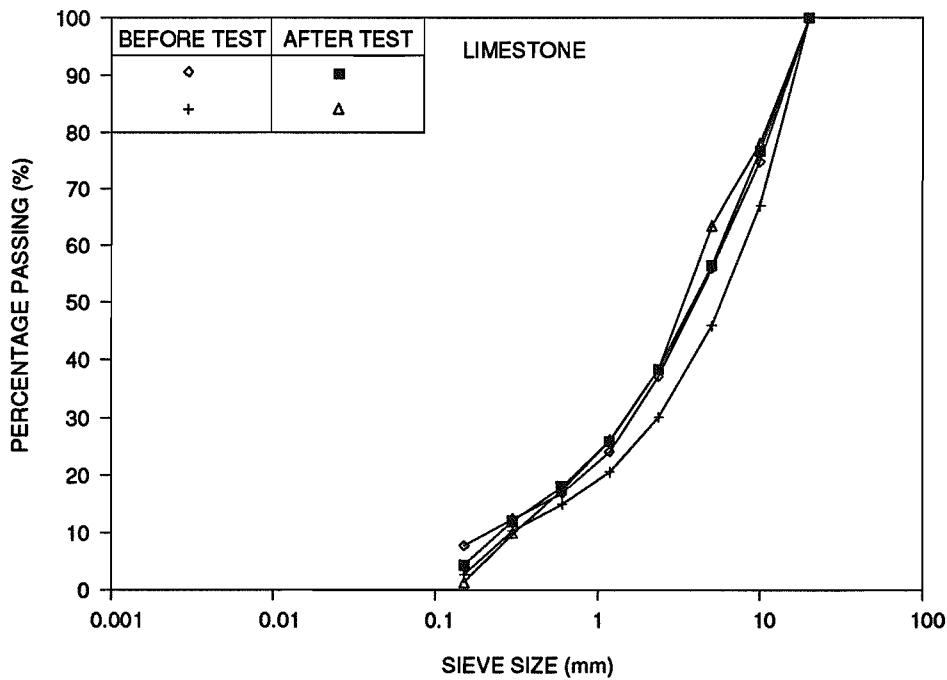

Figure 4.11 Particle gradings of limestone

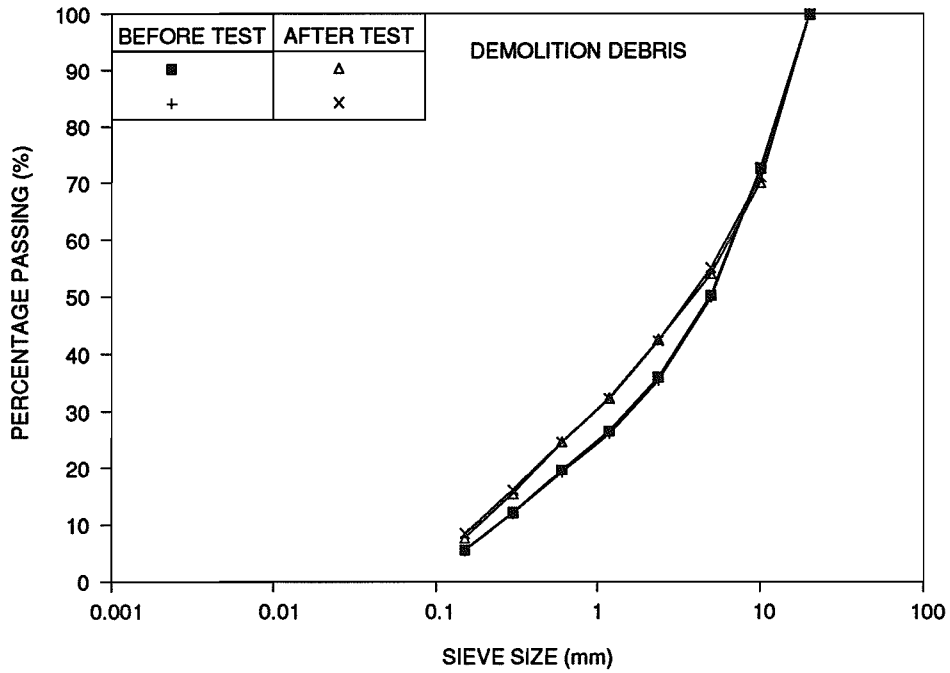

Figure 4.12 Particle gradings of demolition debris

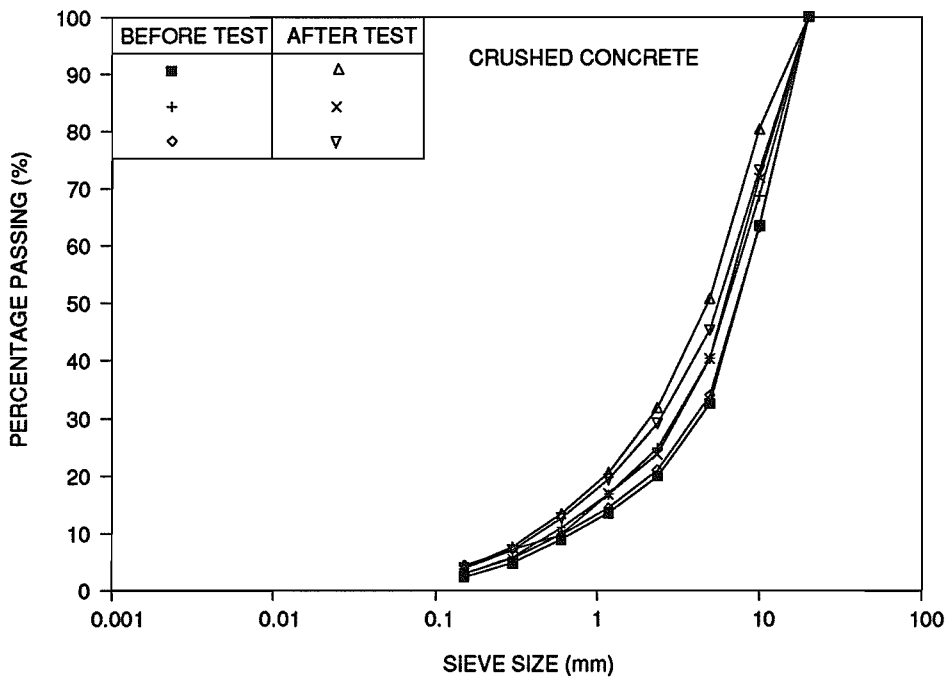

Figure 4.13 Particle gradings of crushed concrete

Usually penetration was carried out shortly after compaction but a couple of saturated samples were allowed to stand to facilitate the dissipation of any pore pressures set up by the compaction process. The plug and filter paper were removed from the mould and the sample was placed under the 50mm diameter plunger in the compression testing machine. No surcharge weights were placed on the samples as it was considered that most damage due to rutting would occur when the sub-base was acting as a construction platform. In this condition the sub-base would be without surcharge.

The plunger was made to penetrate the sample at a rate of 1mm/min, as required by BS 1377 (1975), and readings of force on the plunger were noted at every 0.25mm of penetration until the indentation was 7.5mm in depth. Penetration was measured using a dial gauge with an accuracy of 0.01mm. BS 1377 (1975) suggests when the top surface of a specimen has been tested that the sample can be inverted and a similar test can be performed on the bottom surface. As the height of the sample was only 127mm, it was considered that stresses built up in the sample during penetration of the top surface would cause the CBR of the bottom surface to be higher. It was decided therefore that each sample should be tested only once.

Initially, as stated in BS 1377 (1975), the average result from two samples was taken as the CBR for a particular test condition. However, for some pairs of samples one result could be considerably higher than the other and in these cases additional samples were tested. The large variation in results was particularly obvious for tests on limestone and crushed concrete and was evident at high CBR values in the range of 250% to 500%. As these values were well above the range for which the CBR test was designed, it was likely that large differences at this level were not significant. A CBR value greater than 100% can only be interpreted as meaning that the material had a greater bearing capacity than crushed rock.

The force on the plunger was plotted against penetration for each test and the forces applied at penetrations of 2.5mm and 5mm were noted. BS 1377 (1975) states that if the initial

portion of the curve is concave upwards, the following correction should be made. A tangent should be drawn at the point of maximum slope, as shown in Figure 4.14, and extended to intersect the horizontal axis. The whole curve should then be moved to the left until this intersection coincides with the origin. The forces for 2.5mm and 5mm penetration should then be read from this corrected curve. The CBR is calculated using the formula

$$CBR = \frac{\text{Measured force}}{\text{Standard force}} \times 100\% \quad \dots \text{Eqn 4.2}$$

where the standard force is the force required for the same penetration into a sample of compacted crushed rock (BS 1377, 1975). The standard forces for 2.5mm and 5mm penetration are 13.24kN and 19.96kN respectively and CBR is calculated for both levels of penetration. BS 1377 (1975) states that the higher of the two CBR values should be taken as the final result. For this work, an average of the two results was taken as a more conservative estimate.

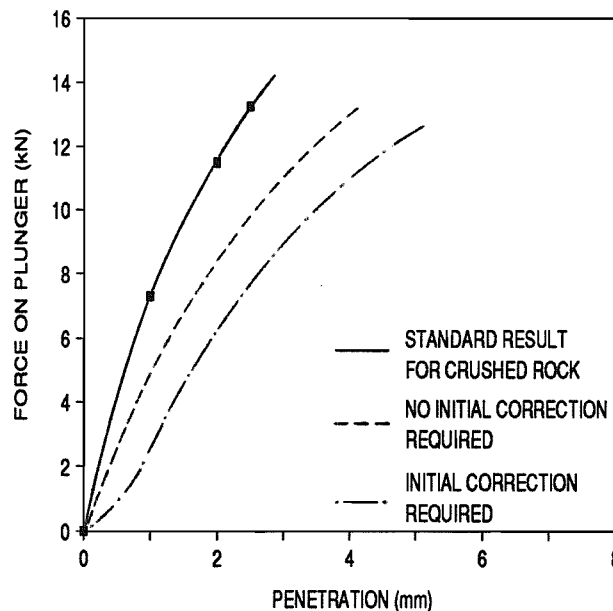

Figure 4.14 Typical force/penetration curves (after BS 1377, 1975)

4.2.3 Results

The force/penetration curves for limestone at moisture contents of approximately 1%, 2% and 3.5% are shown in Figures 4.15, 4.16 and 4.17 respectively. From these data, it can be seen that the initial parts of the plots were concave upwards in most cases so corrections were made using the method described in Section 4.2.2. In Figure 4.17, it can be seen that there were large differences in force between the four samples and in one of the tests, a CBR of 560% was obtained whereas in another test the CBR was 200%. The average CBR of the four tests was 389% and the maximum and minimum CBR values deviated by 44%-49% from this mean. This deviation is very high but, as stated previously, in practical terms high CBR values of this kind are difficult to interpret which consequently makes these large variations in results also hard to understand.

A selection of force/penetration curves for tests on demolition debris are shown in Figures 4.18, 4.19 and 4.20. The scale of the force axis on these graphs is larger than in the previous figures so that interpretation would be easier. The forces in these plots are much lower than those in the figures for limestone although there is less scatter in the results of the demolition debris samples. In Figure 4.19, it can be seen that the force/penetration curves for two demolition debris samples are nearly identical.

Similar data for some of the crushed concrete tests are plotted in Figures 4.21, 4.22 and 4.23 where it can be seen that the forces are higher than those exerted on demolition debris but lower than those on the limestone samples. The curves for each moisture content appear to be similar. These figures are plotted on the same scale as those for limestone.

The CBR results are listed in Tables 4.2, 4.3 and 4.4 for limestone, demolition debris and crushed concrete respectively. The test conditions which include moisture content (MC), bulk density (ρ_b), and dry density (ρ_d) for each of the samples, are also listed in the Tables.

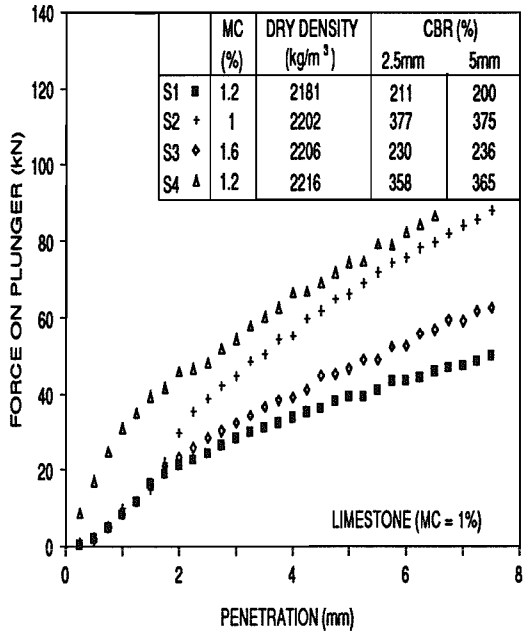

Figure 4.15 Force/penetration curves for limestone at a moisture content of 1%

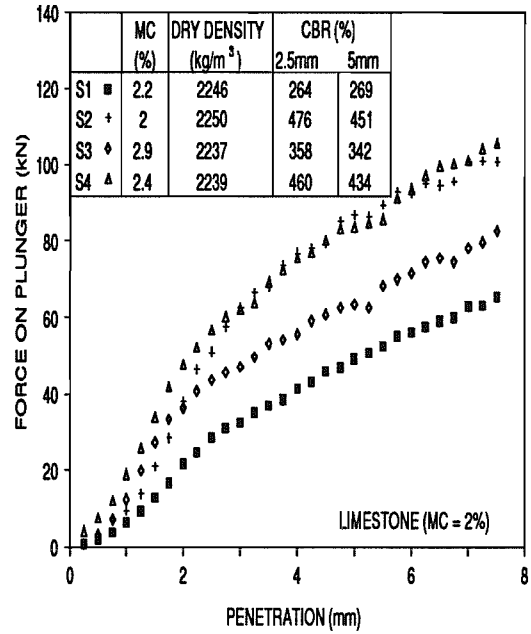

Figure 4.16 Force/penetration curves for limestone at a moisture content of 2%

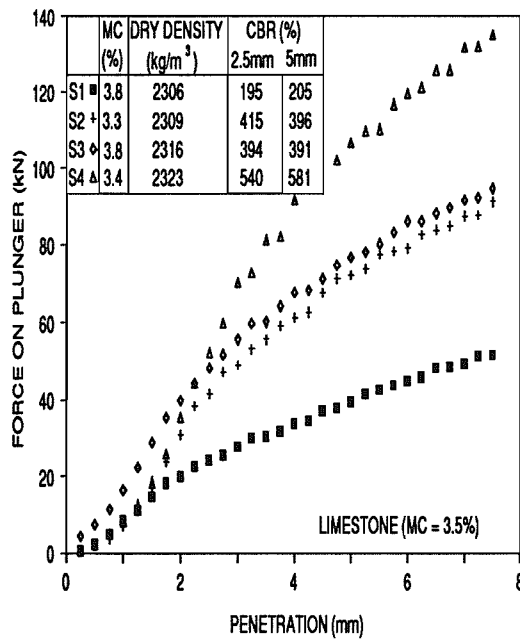

Figure 4.17 Force/penetration curves for limestone at a moisture content of 3.5%

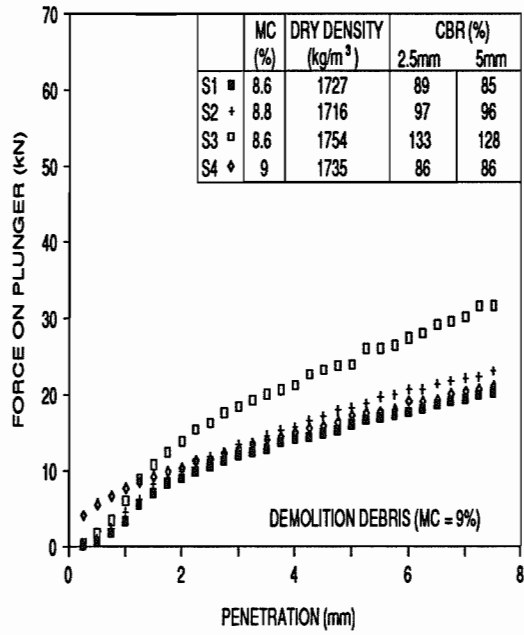

Figure 4.18 Force/penetration curves for demolition debris at a moisture content of 9%

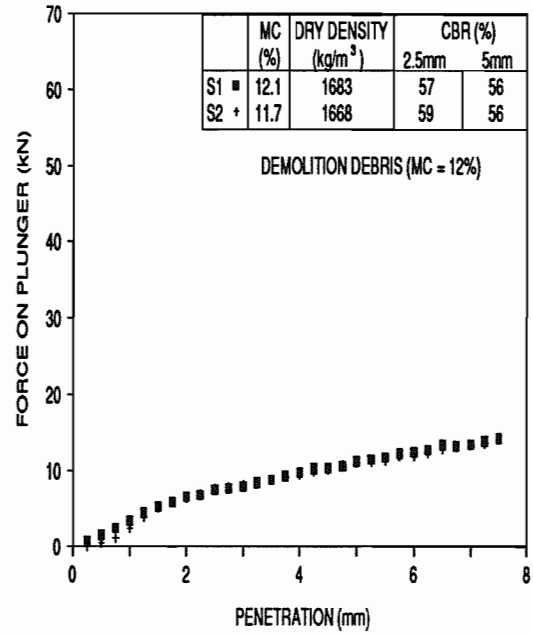

Figure 4.19 Force/penetration curves for demolition debris at a moisture content of 12%

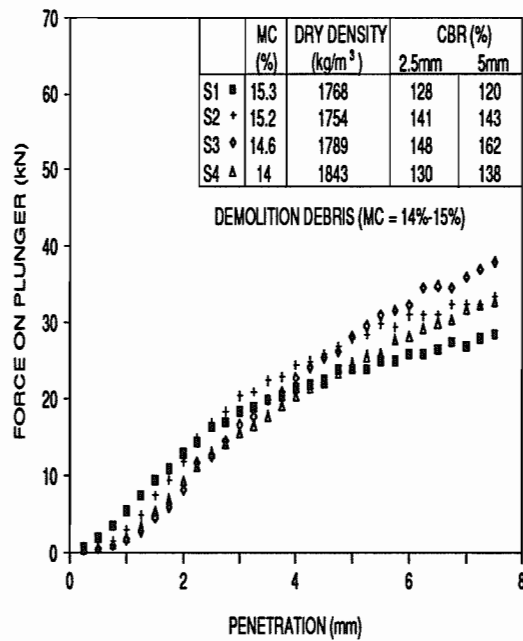

Figure 4.20 Force/penetration curves for demolition debris at a moisture content of 14%-15%

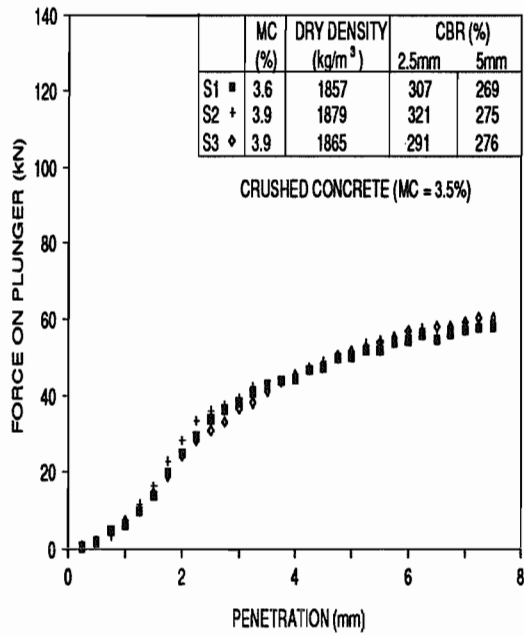

Figure 4.21 Force/penetration curves for crushed concrete at a moisture content of 3.5%

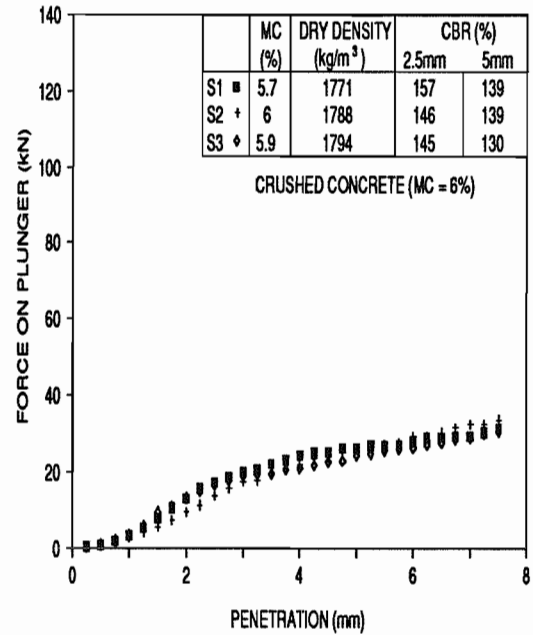

Figure 4.22 Force/penetration curves for crushed concrete at a moisture content of 6%

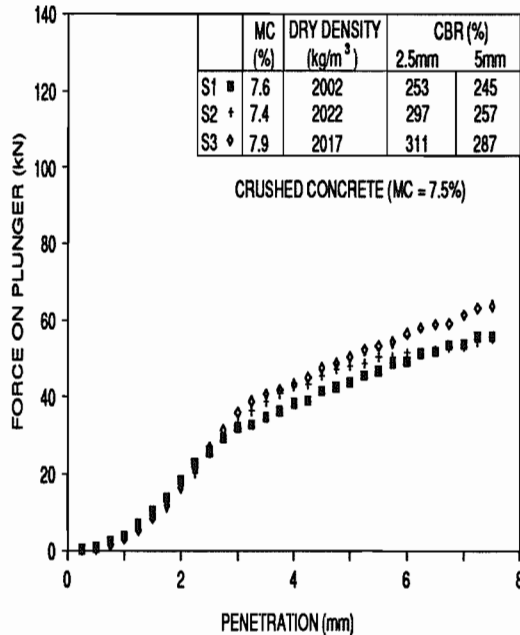

Figure 4.23 Force/penetration curves for crushed concrete at a moisture content of 7.5%

MATERIAL TYPE	MC (%)	ρ_b (kg/m ³)	ρ_d (kg/m ³)	CBR (%)		AVERAGE CBR (%)	STANDARD DEVIATION (%)	
				2.5mm	5mm			
Limestone	0	2167	2167	320	328	324	4	
	0	2149	2149	408	386	397	11	
	1	2225	2202	377	375	376	1	
	1.2	2206	2181	211	200	205.5	5.5	
	1.2	2243	2216	358	365	361.5	3.5	
	1.6	2243	2206	230	236	233	3	
	2	2296	2250	476	451	463.5	12.5	
	2.2	2296	2246	264	269	266.5	2.5	
	2.4	2293	2239	460	434	447	13	
	2.9	2302	2237	358	342	350	8	
	3.3	2385	2309	415	396	405.5	9.5	
	3.4	2406	2323	540	581	560.5	20.5	
	3.8	2404	2316	394	391	392.5	1.5	
	3.8	2393	2306	195	205	200	5	
	4.5	2305	2206	146	132	139	7	
	4.7	2262	2161	104	110	107	3	
	4.9	2337	2229	162	183	172.5	10.5	
	5	2317	2207	177	180	178.5	1.5	
							Average	= 6.8
							S.D.	

Table 4.2 Test conditions and CBR results for limestone

The maximum CBR of demolition debris was about 28% that of the maximum CBR of limestone and crushed concrete and its lowest CBR was between 37% and 39% that of the lowest CBR values of the other two materials which implied that demolition debris had a much lower bearing capacity than the other aggregates. All three materials in any condition, not only at OMC and $\rho_{d,peak}$, complied with the Specification for Highway Works (1986).

The CBR results from 2.5mm and 5mm penetration for each test were averaged and the standard deviation was calculated. It can be seen from the tables that the average of all standard deviations calculated for limestone, demolition debris and crushed concrete were 6.8%, 2.6% and 17.2% respectively. Therefore demolition debris followed more closely the

force/penetration trend of the standard crushed rock referred to in BS 1377 (1975). It was difficult to conduct a statistical analysis on the results of the tests for each target moisture content because there was more scatter than expected.

MATERIAL TYPE	MC (%)	ρ_b (kg/m ³)	ρ_d (kg/m ³)	CBR (%)		AVERAGE CBR (%)	STANDARD DEVIATION (%)
				2.5mm	5mm		
Demolition debris	2.8	1752	1704	120	108	114	6
	3.2	1748	1694	154	138	146	8
	8.6	1876	1727	89	85	87	2
	8.6	1905	1754	133	128	130.5	2.5
	8.8	1867	1716	97	96	96.5	0.5
	9	1891	1735	86	86	86	0
	11.3	1888	1697	68	63	65.5	2.5
	11.3	1882	1691	63	59	61	2
	11.5	1859	1667	48	46	47	1
	12.1	1863	1662	43	40	41.5	1.5
	11.7	1863	1668	59	56	57.5	1.5
	12.1	1887	1683	57	56	56.5	0.5
	14	2101	1843	130	138	134	4
	14.5	2039	1781	88	89	88.5	0.5
	14.6	1965	1714	64	59	61.5	2.5
	14.6	2051	1789	148	162	155	7
	15.2	2021	1754	141	143	142	1
	15.3	2039	1768	128	120	124	4
						Average S.D.	= 2.6

Table 4.3 Test conditions and CBR results for demolition debris

The force/penetration curves for two tests in the crushed concrete series, i.e where the moisture content was 7.8% and 8%, followed an unusual trend. Unlike any of the curves shown earlier, the curves peaked before 5mm penetration and then the slopes decreased. The CBR values measured at a penetration of 2.5mm were very high. Large particles, situated close to the surface under the plunger in the tests, may have had an influence on the

unusual response. Head (1982) states that if the maximum force on a sample is achieved before the end of a test, a CBR value should only be calculated from the part of the curve where the slope is increasing. Therefore the CBR at a penetration of 5mm could not be calculated for these specimens.

MATERIAL TYPE	MC (%)	ρ_b (kg/m ³)	ρ_a (kg/m ³)	CBR (%)		AVERAGE CBR (%)	STANDARD DEVIATION (%)
				2.5mm	5mm		
Crushed concrete	2.2	1964	1922	331	298	314.5	16.5
	2.2	1968	1924	402	334	368	34
	2.3	1982	1938	415	452	433.5	18.5
	2.7	1914	1863	367	340	353.5	13.5
	2.9	1998	1942	542	432	487	55
	2.9	2028	1970	576	444	510	66
	3.6	1925	1857	307	269	288	19
	3.9	1937	1865	291	276	283.5	7.5
	3.9	1953	1879	321	275	298	23
	4.5	1844	1765	149	153	151	2
	4.6	1835	1754	118	104	111	7
	5.1	1838	1749	129	111	120	9
	5.7	1871	1771	157	139	148	9
	5.9	1900	1794	145	130	137.5	7.5
	6	1894	1788	146	139	142.5	3.5
	7.4	2171	2022	297	257	277	20
	7.6	2154	2002	253	245	249	4
	7.8	2345	2174	566	-	566	-
	7.9	2176	2017	311	287	299	12
	8	2066	1913	702	-	702	-
8.1	2325	2151	579	522	550.5	28.5	
10.4	2220	2010	248	216	232	16	
11.2	2149	1933	136	127	131.5	4.5	
11.8	2162	1933	163	169	166	3	
						Average = 17.2	
						S.D.	

Table 4.4 Test conditions and CBR results for crushed concrete

It can be seen in Figure 4.24 that limestone achieved its highest CBR value close to OMC and $\rho_{d,peak}$. Head (1982) states that CBR decreases sharply as a material reaches saturation. This was confirmed by the results of CBR tests conducted on samples above OMC and can be seen in Figure 4.24. Some iso-CBR contours were drawn by interpolation on the plot. If a full investigation was conducted, including tests executed at lower densities, the CBR for any conditions in the field could be estimated. However, as the Specification for Highway Works (1986) requires that aggregate to be used as sub-base material should be compacted to a high density, samples at lower densities were not tested.

Plots, similar to Figure 4.24, are shown for demolition debris and crushed concrete in Figures 4.25 and 4.26 respectively. It is evident from Figure 4.25 that CBR did not decrease close to saturation. When the BS 5835 (1980) compaction test was conducted on demolition debris, an OMC of 13% was determined (Table 4.1). However, it appeared for the CBR series that an OMC of 15% was achieved. This difference in OMC is possibly due to the variation in content of demolition debris. If tests were conducted at higher moisture contents than shown in Figure 4.25, it is likely that there would be a decrease in CBR. In Figure 4.26, which shows the CBR results for crushed concrete, it can be seen that the data are much more useful for plotting iso-CBR contours than in Figures 4.24 and 4.25.

Penetration was conducted immediately after compaction in most cases but some samples of demolition debris were allowed to stand for 24 hours and 72 hours after compaction. This was to observe whether pore pressures, built up during compaction, were released before penetration was conducted or whether a longer period was needed for dissipation to occur. The results of two of these tests are shown in Figure 4.25 (marked 24 hours and 72 hours). Close to the moisture content where these points are plotted, some scatter exists in the results of tests carried out immediately after compaction. The CBR values of the 24 hour and 72

hour tests fall within the range of the other CBR values but it is difficult to determine whether pore pressures existed in the samples. Normally pore pressures built up in granular materials dissipate quite quickly.

In Figure 4.24, it can be seen that the limestone samples were compacted to a density corresponding to more than 5% air voids whereas in Figures 4.25 and 4.26, the saturation of the demolition debris and crushed concrete samples appeared to be much higher. This can be explained by the same reasons given in Section 4.1.3 where it was noted that the difficulty in obtaining an accurate value of the specific gravity of recycled materials was likely to be the main cause of density values falling very close to or to the right of the 0% air voids line.

The influence of V_s (proportion of volume occupied by solids) on CBR for all three materials is shown in Figure 4.27. The CBR values obtained on samples tested at moisture contents above OMC are omitted from this plot. It appears that CBR is a function of the particle packing of the materials although the relationships are not well defined because there is wide scatter in the results. If the values obtained at very high moisture contents were included in this plot, the influence of V_s on CBR would not be as clear.

In Figure 4.28, the effect of moisture content on CBR is examined for crushed concrete. At a certain V_s , CBR appears to be greatly reduced when the moisture content is increased. A similar relationship exists for demolition debris which can be seen in Figure 4.29. In these figures the data at low V_s , which do not appear to follow the general trend of the other results, correspond to the low density point on the dry density/moisture content curve which is normally observed for well graded materials at a moisture content below OMC. It can be seen in Figure 4.30 that moisture content appears to have more of an influence on CBR for limestone but to achieve a certain CBR value, material at a high moisture content must also have a high V_s value. Some caution is needed in the interpretation of these data because of wide scatter in the results.

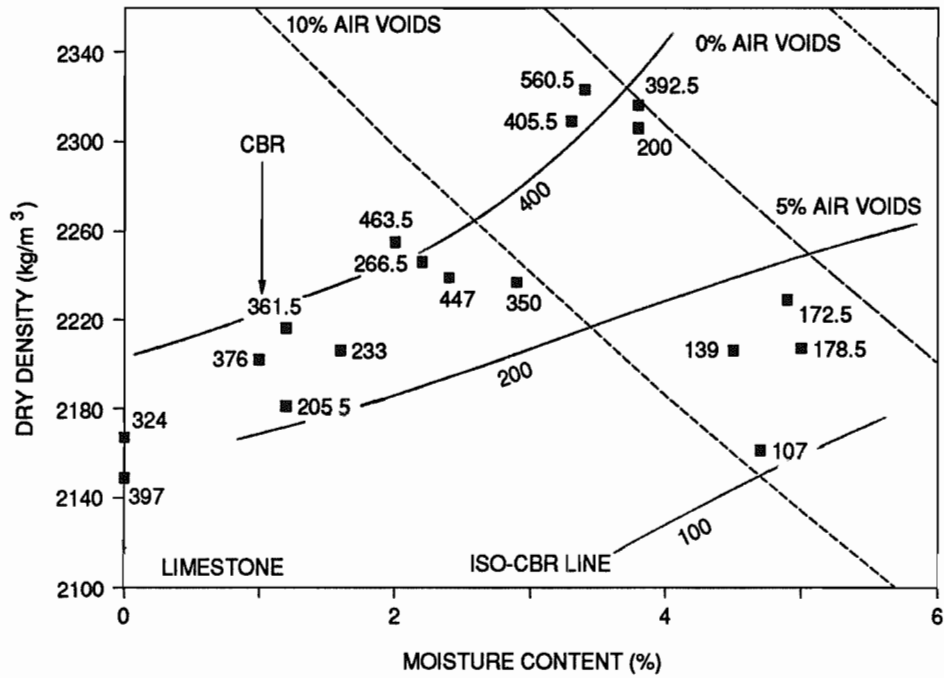

Figure 4.24 CBR values of limestone in relation to dry density and moisture content

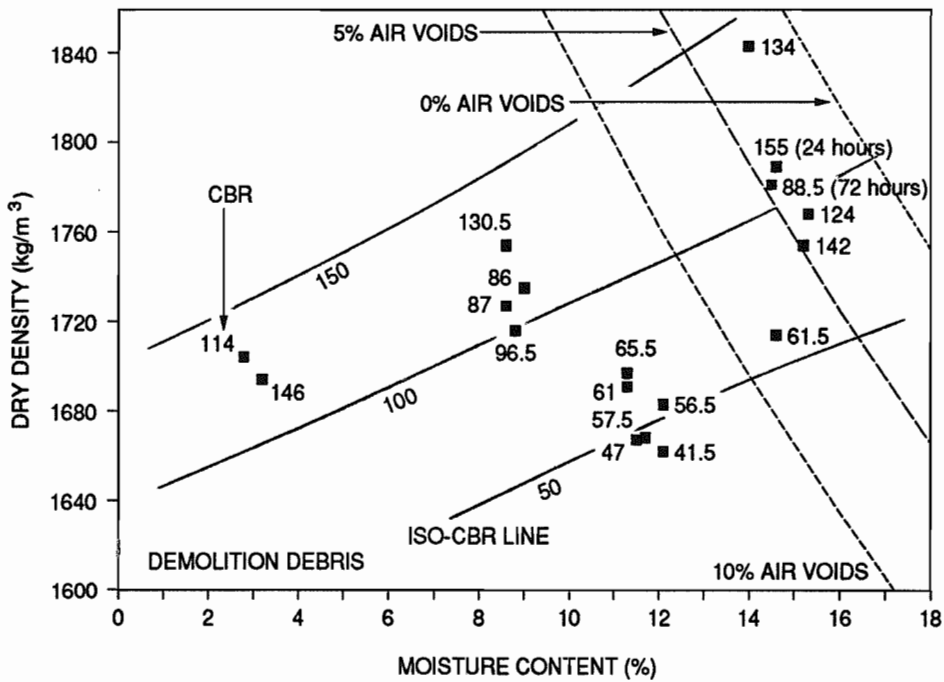

Figure 4.25 CBR values of demolition debris in relation to dry density and moisture content

Note: In Figure 4.25, 24 hours and 72 hours refer to the length of time between compaction and penetration.

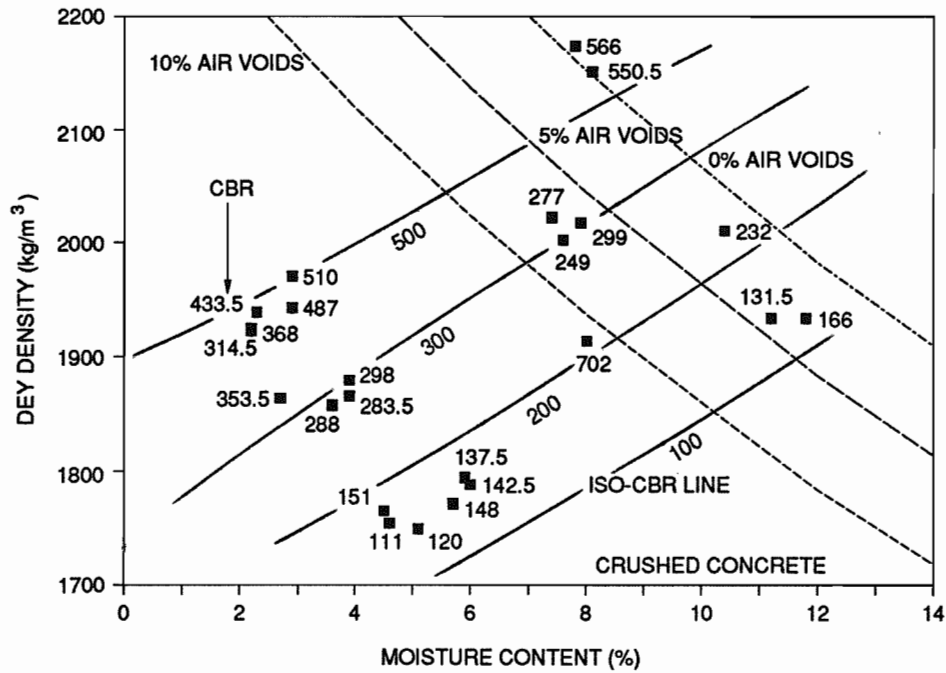

Figure 4.26 CBR values of crushed concrete in relation to dry density and moisture content

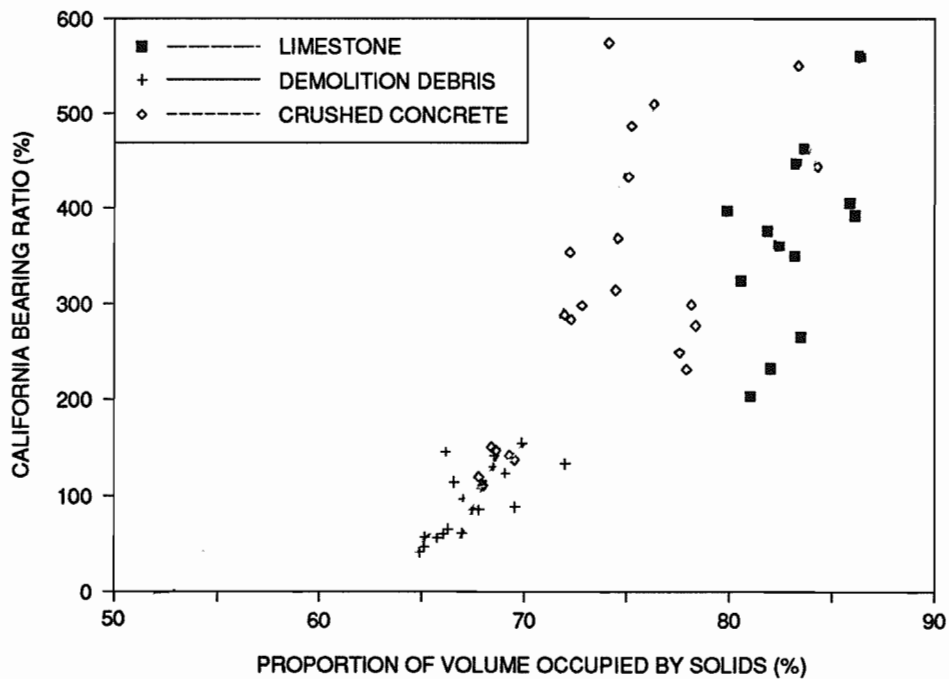

Figure 4.27 Influence of V_s on CBR for the three materials

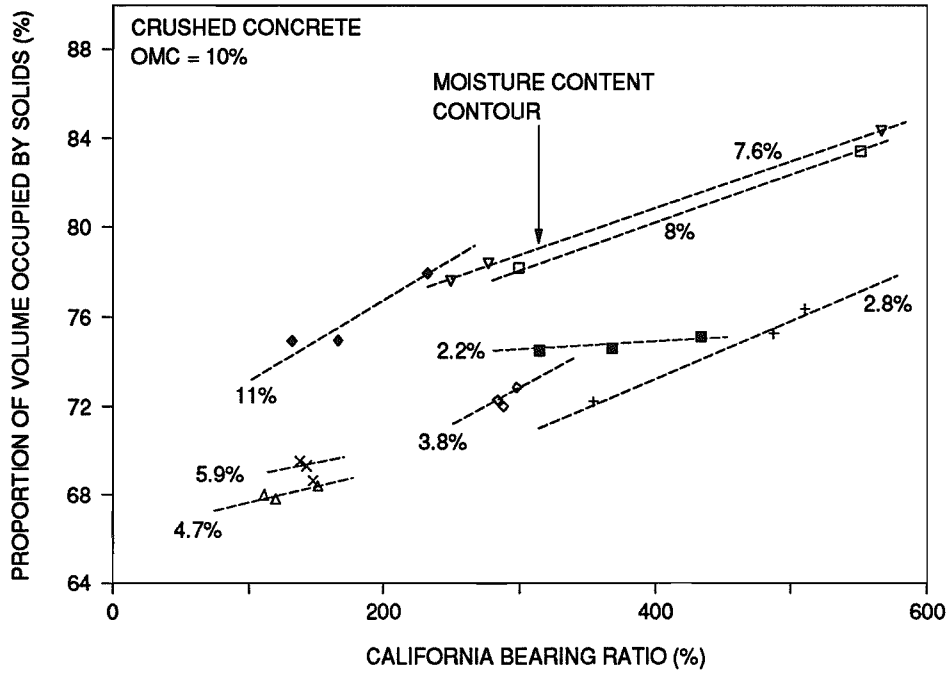

Figure 4.28 Examination of the influence of moisture content on the CBR of crushed concrete

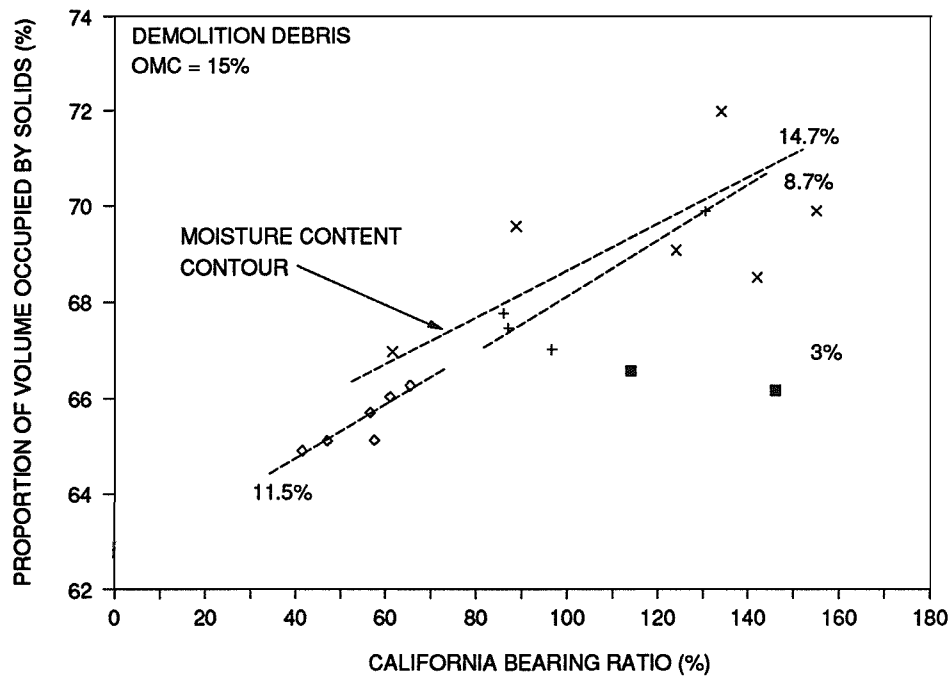

Figure 4.29 Examination of the influence of moisture content on the CBR of demolition debris

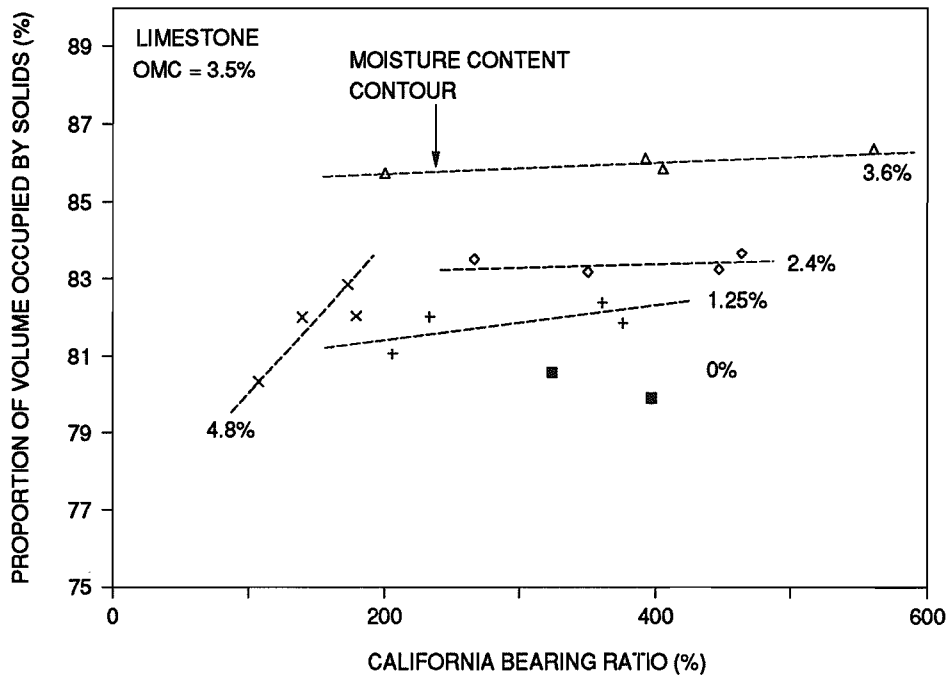

Figure 4.30 Examination of the influence of moisture content on the CBR of limestone

At moisture contents above OMC, V_s is reduced due to the high moisture content and CBR is also reduced e.g. in Figure 4.30 at a V_s of 82%, the CBR at a moisture content of 4.8% is 158% whereas a CBR of 353% is apparent at a moisture content of 1.25%. This is likely to be due to increased lubrication, caused by the excess water, and the reduction of pore suction which would reduce the shear strength of the material.

4.2.4 Analysis

Black (1961) found for clays and sands that in situ values of CBR could be calculated from measurements of cohesion, angle of internal friction and suction using a bearing capacity formula for round footings, developed by Terzaghi (1943), of the form

$$q_u = 1.2cN_c + \gamma dN_q + 0.6\gamma rN_\gamma \quad \dots Eqn \quad 4.3$$

where q_u = ultimate bearing capacity
 c = cohesion
 γ = unit weight of the soil
 d = depth of footing
 r = radius of footing

and N_c , N_q & N_γ are the bearing capacity factors.

Black (1961) stated that in a CBR test the soil is generally close to its ultimate bearing capacity at 2.5mm penetration. The definition for CBR, expressed as

$$CBR = \frac{q_u}{729.6} \times 100 \quad \dots Eqn \ 4.4$$

was used in the analysis, where 729.6 kN/m² is the standard stress required for a penetration of 2.5mm into compacted crushed rock. For sand and clay, Black (1961) obtained good correlation between measured and calculated values of CBR.

A similar procedure was conducted on the data presented in Section 4.2.3. No cohesion existed in the aggregates, suction was assumed to be negligible and no surcharge was placed on the samples in the CBR tests. Therefore, for this analysis Eqn 4.3 reduced to

$$q_u = 0.6\gamma r N_\gamma \quad \dots Eqn \ 4.5$$

For smooth footings, Vesic (1975) used the following formula to obtain N_γ :-

$$N_\gamma \sim 2(N_q - 1) \tan \phi \quad \dots Eqn \ 4.6$$

where
$$N_q = \tan^2 \left(45 + \frac{\phi}{2} \right) e^{\pi \tan \phi} \quad \dots Eqn \ 4.7$$

and ϕ is the angle of internal friction.

Vesic (1975) stated that by using Eqn 4.6, the N_γ values could be approximated with an error not exceeding 10% on the safe side for angles of internal friction in the range $15^\circ < \phi < 45^\circ$.

Eqns 4.6 and 4.7 are the formulae most commonly used for the determination of N_γ and N_q .

For comparison purposes, some bearing capacity factors were calculated using formulae developed by Meyerhof (1951). Vesic (1975) stated that the formulae by Meyerhof (1951) could explain quite well the behaviour of long rectangular plates because the plane strain angle of friction should be used in the formulae. However, interpretation of the behaviour of round footings would be difficult using the Meyerhof values (1951). This may be the reason why much higher bearing capacity factors were obtained when the formulae by Meyerhof (1951) were used.

The ϕ values used in Eqns 4.6 and 4.7 were found by conducting shear box tests on the aggregates at various densities (see Chapter 5). Shear box tests were not conducted at some of the higher densities obtained in the CBR tests so values of ϕ_{ds} (direct shear angle of friction) at these densities were calculated by extrapolation of the lines in Figure 5.22. It is recognised, for an element of material located below the plunger in a CBR test that the loading conditions are similar to those in a triaxial test. However, for an element of material on the shear plane at some distance from the plunger, the conditions are closer to plane strain.

Mayhew (1985) stated that the measured value of CBR on a granular sub-base material in the laboratory could be twice the CBR value which would be obtained if a similar test was conducted in the field. This difference is due to the rigid boundary of the mould in the laboratory test which inhibits the natural failure mechanism and requires a higher stress to be placed on the plunger for penetration. The confining effect of the mould increases as ϕ_{ds}

increases. In the field, the lateral restraint is normally provided by aggregate or soil which would not create as high a confining stress as that exerted by the mould on a sample in the laboratory. Eqn 4.3 was developed for situations in the field and therefore the measured values of CBR in the laboratory were halved before comparing them with the calculated values. It can only be assumed that Black (1961) did not halve his results for clay and sand because of less difference between site CBR values and those obtained in the laboratory for these materials.

The relationship between the measured and calculated values of CBR is shown in Figure 4.31. Due to the high values of ϕ_{ds} corresponding to high dry density values, very few calculated values of CBR could be obtained for limestone and therefore the comparison in Figure 4.31 is for demolition debris and crushed concrete. At low values of ϕ_{ds} and density, the measured values compare well with the calculated values for demolition debris. However, the measured values of CBR for crushed concrete were higher than the calculated values for a wide range of CBR. The scale effects of the test were likely to be the cause of this difference because the ratio of the plunger diameter to the maximum particle size was 2.5. If a particle of 20mm in size was positioned directly below the plunger, the measured CBR would be higher than if the particles under the plunger were e.g. 1/10th to 1/20th of its diameter. Analysis of the problem would be complicated further if a large particle was situated directly on the shear plane. A good correlation between measured and calculated values of CBR was not expected due to the problems mentioned above.

It is clear from Figure 4.31 that the measured CBR values should not have been halved because the difference between site and laboratory values of CBR is likely to be dependent on the type of material. The suggestion by Mayhew (1985) that a factor of a 1/2 should be applied to CBR values measured in the laboratory was a general comment.

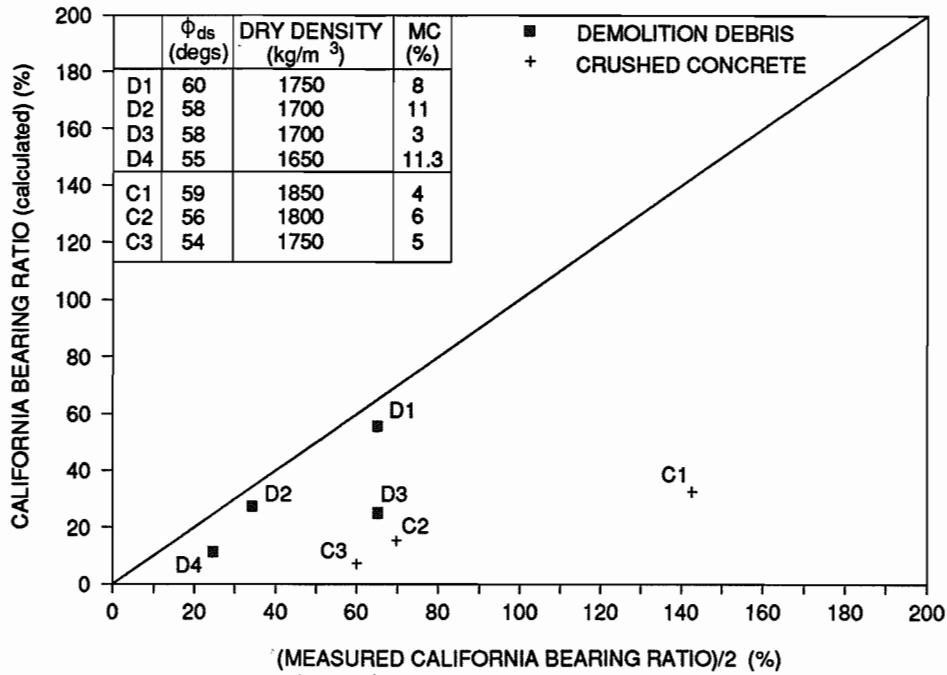

Figure 4.31 Comparison between measured and calculated values of CBR

4.3 Discussion

The standard compaction and CBR tests are conducted in 150mm and 152mm diameter moulds respectively. However, the BS 5835 test (1980) allows particles up to 37.5mm in size to be tested whereas the CBR test, described in BS 1377 (1975), restricts the maximum particle size to 20mm. The Specification for Highway Works (1986) includes both tests for the classification of road sub-base materials but the particle grading to be used in each test is different. It would be more consistent if tests on aggregates, to be used for the same purpose, were conducted on material of the same particle grading and a more useful approach would be to conduct the tests on a similar grading to that expected to be used on site.

When compaction tests were conducted on dry material in the large apparatus, higher densities were obtained than those achieved in the BS 5835 (1980) test. This was due to the greater influence of friction on the sides of the smaller mould during compaction. The

effect of the inclusion of particles greater than 37.5mm in the compaction tests was negligible. It was concluded by Dawson and Jones (1989) that compaction plant, capable of monitoring and recording its own performance together with the response of the material to compaction, would be very useful equipment for pavement construction.

The CBR values obtained for limestone and crushed concrete were similar but it is likely if CBR tests were conducted in the field a few months after placement that the bearing capacity of crushed concrete would be higher due to the self-cementing effect determined by Sweere (1989). In tests conducted by Sweere (1989), it was found after placement that the structural contribution of a 25cm granular sub-base consisting of crushed concrete was equal to that of a 6cm bituminous base. After accelerated loading on trial pavements, Sweere (1989) found that increased bonding due to the self-cementing effect in the recycled material made the material more resistant to rutting than the 6cm bituminous base. Although the CBR of demolition debris in this research was lower than that of limestone and crushed concrete it may be that several months after placement the CBR of demolition debris would also be improved due to the bonding effect.

4.4 Conclusions

- (i) Although the BS 5835 test (1980) was conducted on particles less than 37.5mm in size, it can be concluded from the results of tests conducted in a large apparatus that the inclusion of up to 15% of particles larger than 37.5mm should not alter density significantly.
- (ii) There appeared to be large differences in the $\rho_{d,peak}$ values of the three materials when dry density was plotted against moisture content. However, when the results

were presented in volumetric terms, particle packing of the recycled materials appeared to be similar but the proportion of volume occupied by solids in the limestone samples was higher.

- (iii) In any test condition examined, all aggregates complied with the CBR requirements listed in Clause 804 for Type 2 sub-base materials in the Specification for Highway Works (1986). However, the CBR values of limestone and crushed concrete were significantly higher than those of demolition debris.
- (iv) Although the interpretation was conducted on results of considerable scatter, it appeared that CBR was mainly influenced by particle packing but that moisture content also affected CBR.
- (v) The calculated values of CBR using ϕ_{ds} gave reasonable correlation for demolition debris but the influence of boundary and scale effects was too large to expect any analysis to provide an accurate estimate of CBR.