

The University of Oxford

The Evolution of Visual Representation:  
The elite art of Early Dynastic Lagaš and its antecedents  
in Late Uruk Period Sumer and Predynastic Egypt

Volume Two  
Bibliography, Catalog, and Plates

A dissertation submitted to the Faculty of Oriental Studies  
in candidacy for the degree of D. Phil

by David Nelson Gimbel

Wolfson College

August 2002

## Bibliography

- Abusch, Tzvi, (ed.)  
 2002 *Riches Hidden in Secret Places: Ancient Near Eastern studies in memory of Thorkild Jacobsen*. Winona Lake: Eisenbrauns.
- Adams, Barbara  
 1974a *Ancient Hierakonpolis*. Warminster: Modern Egyptology Series. Warminster: Aris and Phillips.  
 1974b *Ancient Hierakonpolis: Supplement*. Modern Egyptology Series. Warminster: Aris and Phillips.  
 1990 "An Enigmatic Sealing from Abydos." *Eretz-Israel* 21:1-9.  
 1996 "Elite Tombs at Hierakonpolis," in (ed.) Jefferey Spencer, *Aspects of Early Egypt*:1-15. London: British Museum Press.
- Adams, Barbara, and Krzysztof M. Ciałowicz  
 1997 *Protodynastic Egypt*. Shire Egyptology 25. Buckinghamshire: Shire Publications.
- Adams, Barbara, and Renée F. Friedman  
 1992 "Imports and Influences in the Predynastic and Protodynastic Settlement and Funerary Assemblages at Hierakonpolis," in (ed.) Edwin C. M. van den Brink, *The Nile Delta in Transition: 4th - 3rd Millennium B.C.. Proceedings of a Seminar Held in Cairo, 21. - 24 October 1990, at the Netherlands Institute of Archaeology and Arabic Studies*:317-338. Tel Aviv: Distributed by the Israel Exploration Society for Edwin C. M. van den Brink.
- Adams, Robert McC.  
 1965 *Land Behind Baghdad: A history of settlement on the Diyala plains*. Chicago: University of Chicago Press.  
 1981 *Heartland of Cities*. Chicago: University of Chicago Press.
- Adams, Robert McC., and Hans Jörg Nissen  
 1972 *The Uruk Countryside: The natural setting of urban societies*. Chicago: University of Chicago Press.
- Adamson, P. B.  
 1992 "The Possibility of Sea Trade Between Mesopotamia and Egypt During the Late Pre-Dynastic Period." *Aula Orientalis* 10:175-179.
- Adler, Cyrus, and Aaron Ember, (eds.)  
 1926 *Oriental Studies Published in Commemoration of the Fortieth Anniversary (1883-1923) of Paul Haupt as Director of the Oriental Seminary of the Johns Hopkins University, Baltimore, Md*. Baltimore: Johns Hopkins Press.
- Akkermans, Peter M. M. G.  
 1987a "A Late Neolithic and Early Halaf Villiage at Sabi Abyad, Northern Syria." *Paléorient* 13:23-40.  
 1987b "Tell Sabi Abyad: Preliminary report of the 1986 excavations." *Akkadica* 52:10-28.  
 1989a *Excavations at Tell Sabi Abyad: Prehistoric investigations in the Balikh Valley, Northern Syria*, BAR International Series 468. Oxford: BAR.

- 1989b "The Neolithic of the Balikh Valley, Northern Syria: A first assessemant." *Paléorient* 15, 121-133.
- 1997 *Tell Sabi Abyad. The Late Neolithic Settlement: Report on the Excavations of the University of Amsterdam (1988) and the National Museum of Antiquities Leiden (1991-1993) in Syria* (2 Vols.), Uitgaven van het Nederlands Historisch-Archaeologisch Instituut te Istanbul. Publications de l'Institut historique et archéologique néerlandais de Stamboul 76. Leiden: Nederlands Instituut.
- Akkermans, P. M. M. G., and K. Duistermaat  
1997 "Of Storage and Nomads: The sealings from Late Neolithic Sabi Abyad Syria." *Paléorient* 22, 2:17-44.
- Akkermans, Peter M. M. G., and M. Le Mière  
1992 "The 1988 Excavations at Tell Sabi Abyad, A Later Neolithic Village in Northern Syria." *American Journal of Archaeology*, 96:1-22.
- Akkermans, Peter M. M. G., and Marc Verhoeven  
1995 "An Image of Complexity: The burnt village at Late Neolithic Sabi Abyad, Syria." *American Journal of Archaeology* 99:5-32.
- Al-Asil, Naji  
1949 "Dudu, The Sumerian Scribe." *Sumer* 5, 2:131-132.
- Aldred, Cyril  
1987 (rev. ed.) *The Egyptians*. London: Thames and Hudson.
- Algaze, Guillermo  
1993a *The Uruk World System: The dynamics of expansion of early Mesopotamian civilization*. Chicago: University of Chicago Press.  
1993b "Expansionary Dynamics of Some Early Pristine States." *American Anthropologist* 95:304-333.
- Allotte de la Fuÿe, Maurice François  
1907 "Les sceaux de Lougalanda patési de Lagash (Sirpoula) et de sa femme Barnamtara." *Revue d'assyriologie et d'archéologie orientale* 4, 4:105-125.  
1908-1920 *Documents présargoniques*. Paris: E. Leroux.  
1910 "État des décès survenus dans le personnel de la déesse Bau sous la règne d'Urukagina." *Revue d'assyriologie et d'archéologie orientale* 7, 3:139-146.  
1920 "Le sceau de Ur-É-Innana sur un tronc de cône étiquette: étude comparative des sceaux de cette époque." *Revue d'assyriologie et d'archéologie orientale* 17, 1:1-26
- Alster, Bendt  
1972 "'Ninurta and the Turtle', UET 6/1 2." *Journal of Cuneiform Studies* 24, 4:120-125.  
1990 "Lugalbanda and the Early Epic tradition in Mesopotamia," in (eds.) Tzvi Abusch, John Huehnergard, and Piotr Steinkeller, *Lingering Over Words: Studies in ancient Near Eastern literature in honor of William L. Moran*:59-72. Harvard Semitic Studies 37. Atlanta, Georgia: Scholar's Press.  
1991 "Contributions to the Sumerian Lexicon: 1. The reading of AN.IM.IMDUGUD.musen." *Revue d'assyriologie et d'archéologie orientale* 86:1-5.

Alster, Bendt, (ed.)

1980 *Death in Mesopotamia: XXVIe Rencontre assyriologique internationale, Mesopotamia: Copenhagen Studies in Assyriology 8.* Copenhagen: Akademisk Forlag.

Altenmüller, Hartwig

1975 "Flachbildkunst der Frühzeit und des alten Reiches," in (ed.) Claude Vandersleyen, *Das alten Ägypten: 273-291.* Propyläen Kunstgeschichte 17. Berlin: Propyläen Verlag.

Althusser, Louis

1971 [1969] "Ideology and Ideological State Apparatuses (Notes Towards an Investigation)," in (ed.) Ben Brewster, *Lenin and Philosophy and Other Essays: 127-186.* New York: Monthly Review Press.

Amiet, Pierre

1966 "Il y a 5000 ans Elamites inventaient l'écriture." *Archeologia* 12:16-23.

1972 *Glyptique Susienne des origines à l'époque des Perses Achéménides: Cachets, sceaux-cylindres et empreintes antiques découverts à Suse de 1913 à 1967 (2 Vols.).* Mémoires de la Délégation Archéologique en Iran 43. Paris: Librairie Orientaliste Paul Geuthner.

1980a *Art of the Ancient Near East.* New York: Abrams.

1980b *La glyptique Mésopotamienne archaïque (deuxième édition revue et corrigée avec un supplément).* Paris: Éditions du Centre National de la Recherche Scientifique.

1986a *L'âge des échanges inter-iraniens: 3500-1700 avant J.-C.* Notes et documents des musées de France 11. Paris: Ministère de la Culture et de la Communication- Éditions de la Réunion des Musées Nationaux.

1986b "Le problème de l'iconographie divine en Mésopotamie dans la glyptique antérieure à l'époque d'Agade." *Contributi e materiali di archeologia orientale* 1:1-61.

Amiran, Ruth

1992 "Petrie's F-Ware," in (ed.) Edwin C. M. van den Brink, *The Nile Delta in Transition: 4th - 3rd Millennium B.C.. Proceedings of a Seminar Held in Cairo, 21. - 24 October 1990, at the Netherlands Institute of Archaeology and Arabic Studies: 427-432.* Tel Aviv: Distributed by the Israel Exploration Society for Edwin C. M. van den Brink.

Amiran, Ruth, and Ram Gophna

1992 "The Correlation Between Lower Egypt and Southern Canaan During the EB1 Period," in (ed.) Edwin C. M. van den Brink, *The Nile Delta in Transition: 4th - 3rd Millennium B.C.. Proceedings of a Seminar Held in Cairo, 21. - 24 October 1990, at the Netherlands Institute of Archaeology and Arabic Studies: 357-360.* Tel Aviv: Distributed by the Israel Exploration Society for Edwin C. M. van den Brink.

Armstrong, David F., William C. Stokoe, and Sherman Wilcox

1995 *Gesture and the Nature of Language.* Cambridge: Cambridge University Press.

Arnett, William S.

1982 *The Predynastic Origins of Egyptian Hieroglyphs: Evidence for the development of rudimentary forms of hieroglyphs in Upper Egypt in the fourth millennium B.C.* Washington DC: University Press of America.

Arnheim, Rudolf

1969 *Visual Thinking*. London,: Faber.

1974 (rev. ed.) *Art and Visual Perception: A psychology of the creative eye*. Berkeley: University of California Press.

1988 *The Power of the Center: A study of composition in the visual arts*. Berkeley: University of California Press.

Arnold, Dieter

1992 *Die Tempel Ägyptens: Götterwohnungen, Kultstätten, Baudenkmäler*. Zürich: Artemis & Winkler.

Asher-Greve, Julia M.

1985 *Frauen in altsumerischer Zeit*. Bibliotheca Mesopotamica 18. Malibu: Undena.

1989 "Observations on the Historical Relevance of Visual Imagery in Mesopotamia," in (ed.) Albert de Pury, *Histoire et conscience dans les civilisations du proche-orient (Actes du Colloque de Cartigny 1986)*. Les cahiers du Cepoa 5. Leuven: Éditions Peeters.

1995-1996 "Reading the Horned Crown: A review article." *Archiv für Orientforschung* 42/43:181-189.

Asselberghs, Henri

1961 *Chaos en Beheersing: Documenten uit het aeneolithisch Egypte*. Documenta et monumenta orientis antiqui pertinentia 8. Leiden: E. J. Brill.

Atran, Scott

1986 "The Nature of Folk-Botanical Life Forms." *American Anthropologist* 87, 2:298-315.

1990 *Cognitive Foundations of Natural History: Towards an anthropology of science*. Cambridge: Cambridge University Press.

Aurenche, Oliver, Jacques Evin, and Francis Hours, (eds.)

1987 *Chronologies du Proche Orient. Chronologies in the Near East: Relative chronologies and absolute chronology 16,000 - 4,000 B.P. C.N.R.S. International Symposium Lyon (France) 24-28 November 1986 (2 Vols.)*, Maison de l'Orient Méditerranéen (C.N.R.S. Université Lumière - Lyon 2), Lyon, France: Archaeological Series 3. British Archaeological Reports: International Series 379 (i). Oxford: British Archaeological Reports.

Austin, John L.

1975a *How to do Things With Words: The William James Lectures delivered at Harvard University in 1955*. Cambridge, Massachusetts: Harvard University Press.

1975b *Philosophical Papers*. Oxford: Oxford University Press.

Averbeck, Richard E.

1987 *A Preliminary Study of Ritual and Structure in the Cylinders of Gudea (2 Vols.)*. Ph.D. dissertation, The Dropsie College.

Ayrton, E. R. , C. T. Currelly, and A. E. P. Weigal

1904 *Abydos: Part III*. The Egypt Exploration Fund Memoirs 25. London: Kegan Paul, Trench, Trübner and Co.

- Ayrton, E. R. , and W. L. S. Loat  
1911 *Predynastic Cemetery at El Mahasna*. The Egypt Exploration Fund Memoirs 31. London: Kegan Paul, Trench, Trübner and Co.
- Babelon, Ernest  
1888 *Manuel d'archéologie orientale: Chaldée, Assyrie, Perse, Syrie, Judée, Phénicie, Carthage*. Bibliothèque de l'enseignement des beaux-arts. Paris: Maison Quantin.
- Bahrani, Zainab  
1989 *The Administrative Building at Tell Al Hiba, Lagash*. Ph.D. dissertation, New York University.
- Bailey, Craig H., and Eric R. Kandel  
1995 "Molecular and Structural Mechanisms Underlying Long-term Memory," in (eds.) Michael S. Gazzaniga and Emilio Bizzi, *The Cognitive Neurosciences*:19-36. A Bradford Book. Cambridge, Mass: MIT Press.
- Baines, John  
1985a *Fecundity Figures: Egyptian personification and the iconology of a genre*. Warminster: Aris & Phillips.  
1985b "Color Terminology and Color Classification: Ancient Egyptian color terminology and polychromy." *American Anthropologist* 87, 2:284-297.  
1988 "Literacy, Social Organization, and the Archaeological Record: The case of early Egypt," in (eds.) J. Geldhill, B. Bender, and M. T. Larsen, *State and Society: The Emergence and development of social hierarchy and political centralization*:192-214. *One World Archaeology* 4. London: Routledge & Kegan Paul.  
1989 "Communication and Display: The integration of early Egyptian art and writing." *Antiquity* 63:471-482.  
1991 "On the Symbolic Context of the Principal Hieroglyph for 'God'," in (eds.) Ursula Verhoeven and Erhart Graefe, *Religion und philosophie im alten Ägypten: Festgabe für Philippe Derchain zu seinem 65. Geburtstag am 24 Juli 1991*:29-46. Leuven: Uitgeverij Peeters.  
1993 "Symbolic Roles of Canine Figures on Early Monuments." *Archéo-Nil* 3:57-74.  
1995a "Kingship, Definition of Culture, and Legitimation," in (eds.) David O'Connor and David P. Silverman, *Probleme der Ägyptologie* 9:3-47, 300-329 (bibliography). *Ancient Egyptian Kingship*. Leiden: E. J. Brill.  
1995b "Origins of Egyptian Kingship," in (eds.) David O'Connor and David P. Silverman, *Ancient Egyptian Kingship*:95-156, 300-329 (bibliography). *Probleme der Ägyptologie* 9. Leiden: E. J. Brill.  
1996 "Contextualizing Egyptian Representations of Society and Ethnicity," in (eds.) Jerrold S. Cooper and Glenn M. Schwartz, *The Study of the Ancient Near East in the Twenty First Century: The William Foxwell Albright Centennial Conference*:339-384. Winona Lake, Indiana: Eisenbrauns.  
1997 "Review of *Das System der ägyptischen Hieroglyphenschrift in der 0.-3. Dynastie* by Jochem Kahl." *Die Welt des Orients* 28:170-173.  
1999 "Scrittura e società nel più antico Egitto," in (ed.) Francesco Tiradritti, *Sesh: Lingue e scritture nell'antico Egitto*:21-30. inediti dal Museo Archeologico di Milano. Milan: Electa.
- Baines, John, and Jaromír Málek  
1987 *Atlas of Ancient Egypt*. New York: Facts on File.

- Baines, John, and Norman Yoffee  
 1998 "Order, Legitimacy, and Wealth in Ancient Egypt and Mesopotamia," in (eds.) Gary M. Feinman and Joyce Marcus, *Archaic States*:199-260. Santa Fe: School of American Research Press.
- Bakhtin, Mikhail  
 1984 [1968] *Rabelais and his World*. Translated by Hélène Iswolsky. Bloomington: Indiana University Press.  
 1994 "Discourse in the Novel," in (eds.) Michael Holquist and Caryl Emerson, *The Dialogic Imagination: Four essays by M. M. Bakhtin*:259-422. Austin: University of Texas Press.
- Bal, Mieke  
 1985 *Narratology: Introduction to the theory of narrative*. Translated by Christine van Boheeman. Toronto: University of Toronto Press.
- Bal, Mieke, and Norman Bryson  
 1991 "Semiotics and Art History." *Art Bulletin* 73:174-208.
- Balke, Thomas E., Manfred Dietrich, and Oswald Loretz, (eds.)  
 1998 *Dubsar anta-men : Studien zur Altorientalistik : Festschrift für Willem H. Ph. Römer zur Vollendung seines 70. Lebensjahres, mit Beiträgen von Freunden, Schülern und Kollegen*, Alter Orient und Altes Testament 253. Münster: Ugarit-Verlag.
- Banks, Edward James  
 1912 *Bismaya or the Lost City of Adab: A story of adventure, of exploration and of excavation among the ruins of the oldest of the buried cities of Babylonia*. New York: G. P. Putnam's Sons.
- Barber, E. J. W.  
 1991 *Prehistoric Textiles: The development of cloth in the neolithic and bronze ages with special reference to the Aegean*. Princeton: Princeton University Press.
- Bard, Kathryn A.  
 1992 "Origins of Egyptian Writing," in (eds.) Renée F. Friedman and Barbara Adams, *The Followers of Horus: Studies dedicated to Michael Allen Hoffman 1944-1990*:297-306. Egyptian Studies Association Publication 2. Oxbow Monograph 20. Oxford: Oxbow Books.
- Barkow, Jerome H., Leda Cosmides, and John Tooby, (eds.)  
 1992 *The Adapted Mind: Evolutionary psychology and the generation of culture*. Oxford: Oxford University Press.
- Baron-Cohen, Simon  
 1995 *Mindblindness: An essay on autism and theory of mind*. Learning, development, and conceptual change. Cambridge, Mass: MIT Press.
- Barrelet, Marie-Thérèse  
 1970 "Peut-on remettre en question la 'restitution matérielle de la stèle de vautours'?" *Journal of Near Eastern Studies* 29, 4:233-259.

- Barrow, John D.  
1992 *Pi in the sky: Counting, thinking and being*. Penguin Mathematics. London: Oxford University Press.
- Barsalou, Lawrence W.  
1983 "Ad-hoc categories." *Memory and Cognition* 11:211-227.
- Barthes, Roland  
1977 *Image, Music, Text*. Translated by Stephen Heath. New York: Hill and Wang.  
1984 *The Semiotic Challenge*. Translated by Richard Howard. Berkeley: University of California Press.
- Barwise, Jon, and John Perry  
1999 [1983] *Situations and Attitudes*. The David Hume Series. Stanford: CSLI Publications.
- Basmachi, Faraj  
1949 "The Lion Hunt Stele." *Sumer* 5, 1:49-54.  
1959 "The Stele of Ur-Nanshe in the Iraq Museum (article written in Arabic)." *Sumer* 15.  
1960 "The Stele of Ur-Nanshe in the Iraq Museum." *Sumer* 16:45-47.  
1975-1976 *Treasures of the Iraq Museum*. Baghdad: Republic of Iraq, Ministry of Information.  
1994 *Cylinder Seals in the Iraq Museum: Uruk and Jamdat Nasr periods*. Edubba 3. London: Nabu Publications.
- Basmachi, Faraj, and Dietz Otto Edzard  
1958 "Statue of a Son of Enánatum I in the Iraq Museum." *Sumer* 14:109-114.
- Bauer, Josef  
1973-1974 "Altsumerische Beiträge (4-6)." *Die Welt des Orients* 7:9-15.  
1980-1983 "Lagas. A. Philologisch," in (ed.) Dietz Otto Edzard, *Reallexikon der Assyriologie und vorderasiatischen Archäologie (Sechster Band)*:419-422. Berlin und New York: Walter de Gruyter.  
1998 "Die vorsargonische Abschnitt der mesopotamischen Geschichte," in (eds.) Josef Bauer, Robert K. Englund, and Manfred Krebernik, *Mesopotamien: Späturuk-Zeit und frühdynastische Zeit*, *Orbis Biblicus et Orientalis* 160/1:431-585. Freiburg: Universitätsverlag.
- Bauer, Josef, Robert K. Englund, and Manfred Krebernik  
1998 *Mesopotamien: Späturuk-Zeit und frühdynastische Zeit*. *Orbis Biblicus et Orientalis* 160/1. Fribourg: Editions Universtaires Fribourg.
- Baumgartel, Elsie J.  
1955 *The Cultures of Prehistoric Egypt: I (rev. ed.)*. London: Oxford University Press.  
1960 *The Cultures of Prehistoric Egypt: II*. London: Oxford University Press.  
1968 "About Some Ivory Statuettes from the Main Deposit at Hierakonpolis." *Journal of the American Research Center in Egypt* 7:11-14.

1969-1970 "Some Additional Remarks on the Hierakonpolis Ivories." *Journal of the American Research Center in Egypt* 8:9-10.

1970 *Petrie's Naqada Excavations: A supplement*. London: Bernard Quartich.

Beale, Thomas W.

1973 "Early Trade in Highland Iran: A view from a source area." *World Archaeology* 5, 2:135-148.

Becker, Andrea

1993 *Uruk - Kleinfunde I: Stein*. Ausgrabungen in Uruk-Warka: Endberichte 6. Deutsches Archäologisches Institut, Abteilung Baghdad. (ed.) R. M. Boehmer. Mainz am Rhein: Philipp von Zabern.

Behm-Blancke, Manfred Robert

1979 *Das Tierbild in der altmesopotamischen Rundplastik: Eine Untersuchung zum Stilwandel des frühsumerischen Rundbildes*. Deutsches Archäologisches Institute, Abteilung Baghdad: Baghdader Forschungen 1. Mainz am Rhein: Philipp von Zabern.

Behrens, Hermann, Darlene Loding, and Martha T. Roth

1989 *DUMU-E2-DUB-BA-A: Studies in honor of Åke Sjöberg*. Occasional Publications of the Samuel Noah Kramer Fund 11. Philadelphia: The University Museum.

Behrens, Hermann, and Horst Steible

1983 *Glossar zu den Altsumerischen Bau- und Weihinschriften*. Freiburger Altorientalische Studien 6. Wiesbaden: Franz Steiner Verlag GmbH.

Bénédite, Georges

1903 "Un nouvelle palette en schiste." *Fondation Eugène Piot / Monument et Memoires* 11:105-122.

1916 "Le couteau de Gebel el'Arak: étude sur un nouvel objet préhistorique acquis par le Musée du Louvre." *Fondation Eugène Piot / Monument et Memoires* 22:1-34.

1918 "The Carnarvon Ivory." *The Journal of Egyptian Exploration* 5.

Benito, Carlos Alfredo

1969 '*Enki and Ninmah*' and '*Enki and the World Order*'. Ph.D. dissertation, University of Pennsylvania.

Bergmann, Bettina Ann, and Christine Kondoleon, (eds.)

1999 *The Art of Ancient Spectacle*, Studies in the History of Art 56. Washington: National Gallery of Art.

Berlin, Adele

1979 *Enmerkar and Ensuhkešdanna: A Sumerian narrative poem*. Occasional Publications of the Babylonian Fund 2. Philadelphia: University Museum.

Berlin, Brent

1992 *Ethnobiological Classification: Principles of categorization of plants and animals in traditional societies*. Princeton: Princeton University Press.

- Berlin, Brent, and Paul Kay  
1991 [1969] *Basic Color Terms: Their universality and evolution*. Berkeley: University of California Press.
- Berlin, Isaiah  
1967 *The Hedgehog and the Fox: An essay on Tolstoy's view of history*. London: Phoenix.
- Bersani, Leo, and Ulysee Dutoit  
1979 "The Forms of Violence." *October* 8.  
1985 *The Forms of Violence: Narrative in Assyrian art and modern culture*. New York: Schocken Books.
- Bickerton, Derek  
1996 *Language and Human Behavior*. London: UCL Press.
- Biggs, Robert D.  
1973 "Pre-Sargonic Riddles from Lagash." *Journal of Near Eastern Studies* 32:26-33.  
1976 "Eannatum I of Lagash and Ur-Lumma of Umma- A New Text," in (ed.) J. W. Hennerdinger Barry Eichler, and Å. Sjöberg, *Samuel Noah Kramer Anniversary Volume: Cuneiform studies in honor of Samuel Noah Kramer*:33-40. *Alter Orient und Altes Testament Veröffentlichungen zur Kultur und Geschichte des Alten Orients und des Alten Testaments* 25. Kevelar; Neukirchen-Vluyn.  
1992 *Inscriptions from Al-Hiba-Lagash: The first and second seasons (reprinted with addenda)*. Malibu: Undena.
- Birch, Samuel, and Theophilus Goldridge Pinches  
1880-1902 *The Bronze Ornaments of the Palace Gates of Balawat [Shalmaneser II. B.C. 859-825], with Descriptions and Translated by Theophilus G. Pinches*. Society of Biblical Archeology. London.
- Black, Jeremy A.  
1988 "The Slain Heroes - Some Monsters of Ancient Mesopotamia." *The Society for Mesopotamian Studies Bulletin* 15.
- Black, James E., Anita M. Sirevaag, Christopher S. Wallace, *et. al.*  
1989 "Effects of Complex Experience on Somatic Growth and Organ Development in Rats." *Developmental Psychology* 22, 7:727-752.
- Blackmore, Susan  
1999 *The Meme Machine*. Oxford: Oxford University Press.
- Blench, Roger, and Matthew Spriggs, (eds.)  
1997 *Archaeology and Language I: Theoretical and Methodological Orientations*, *One World Archaeology* 27. London: Routledge & Kegan Paul.
- Bock, Barbara, Eva Christiane Cancik-Kirschbaum, and Thomas Richter, (eds.)  
1999 *Munuscula Mesopotamica: Festschrift für Johannes Renger*, *Alter Orient und Altes Testament* 267. Münster: Ugarit-Verlag.

Bock, Gregory R., and Gail Cardew, (eds.)

1997 *Characterizing Human Psychological Adaptations*, Ciba Foundation Symposium 208. Chichester: John Wiley & Sons.

Boehmer, Rainer Michael

1965 *Die entwicklung der Glyptic während der Akkad-Zeit*. Untersuchungen zur Assyriologie und Vorderasiatischen Archäologie 4. Berlin: Walter de Gruyter.

1967 "Die Entwicklung der Hörnerkrone von ihren Anfängen bis zum Ende der Akkad-Zeit." *Berliner Jahrbuch für Vor- und Frühgeschichte* 7:273-288.

1969 "Zur Glyptic zwischen Mesilim- und Akkad-Zeit (Early Dynastic III)." *Zeitschrift für Assyriologie und Vorderasiatische Archäologie* 59:261-292.

1974a "Orientalisch einflüsse auf verzierten Messergriffen aus dem prädynastischen Ägypten." *Archaeologische Mitteilungen aus Iran, Neue Folge* 7:15-40.

1974b "Das Rollsiegel im prädynastischen Ägypten." *Archäologischer Anzeiger* 4:495-514.

1975a "Glyptic von der frühsumerischen bis zum Beginn der altbabylonischen Zeit," in (ed.) Winfried Orthmann, *Der alte Orient*:179-193. Propyläen Kunstgeschichte 14.

Berlin: Propyläen Verlag.

1975b "Kleinasiatische Glyptic," in (ed.) Winfried Orthmann, *Der alte Orient*:179-193. Propyläen Kunstgeschichte 14. Berlin: Propyläen Verlag.

1987 "Lugalanda-Stufe," in (ed.) D. O. Edzard, *Reallexikon der Assyriologie (Siebter Band)*:111-114. Berlin: Walter de Gruyter.

1991a "Gebel-el-Arak- und Gebel-el-Tarif-Griff: keine Fälschungen." *Mitteilungen des Deutschen Archäologischen Instituts, Abteilung Kairo* 47:51-60.

1991b "14C Daten aus Abydos und Uruk - Ägyptisches (?) im frühen Nordsyrien, Sumer und Elam." *Mitteilungen des Deutschen Archäologischen Instituts, Abteilung Baghdad* 22:223-230.

1999 *Uruk - Früheste Siegelabrollungen*. Ausgrabungen in Uruk-Warka: Endberichte 24. Deutsches Archäologisches Institut, Abteilung Baghdad. (ed.) R. M. Boehmer. Mainz am Rhein: Philipp von Zabern.

Boehmer, Rainer Michael, Günter Dreyer, and Bernd Kromer

1993 "Einige frühzeitliche 14C-Datierungen aus Abydos und Uruk." *Mitteilungen des Deutschen Archäologischen Instituts, Abteilung Kairo* 49:63-68.

Boese, Johannes

1971 *Altmesopotamische Weiplatten: Eine sumerische Denmalsgattung des 3 Jahrtausends v. Chr.* Untersuchungen zur Assyriologie und vorderasiatischen Archäologie 4. Berlin: Walter de Gruyter.

1975 "Sumerische-Akkadisches Kunsthandwerk," in (ed.) Winfried Orthmann, *Der alte Orient*:179-193. Propyläen Kunstgeschichte 14. Berlin: Propyläen Verlag.

1978 "Mesanepada und der Schatz von Mari." *Zeitschrift für Assyriologie und Vorderasiatische Archäologie* 68:6-33.

Boessneck, Joachim

1988 *Die Tierwelt der alten Ägypten: Untersucht anhand kulturgeschichtlicher und zoologischer Quellen*. Munich: C. H. Beck.

Boissier, Alfred

1903 "Les Pilliers de Tello. Review of *Un Palais Chaldéen* by M. Heuzey." *Orientalische Litteratur-Zeitung* 11:468-469.

Bolz, William G.

1986 "Early Chinese Writing." *World Archaeology* 17, 3:427 ff.

1994 *The Origin and Development of the Chinese Writing System*. American Oriental Series 78. New Haven: American Oriental Society.

Boone, Elizabeth Hill, and Walter D. Mignolo

1994 *Writing Without Words: Alternative Literacies in Mesoamerica and the Andes*. Durham: Duke University Press.

Bord, Lucien-Jean

2001 *Petit lexique du Sumérien à l'usage de débutants*. Geuthner. Paris.

Borger, Rykle

1967 *Handbuch der Keilschriftliteratur (Band I). Repertorium der Sumerischen und Akkadischen Texte*. Berlin: Walter de Gruyter.

1975 *Handbuch der Keilschriftliteratur (Band III). Inhaltliche ordnung: Der Sumerischen und Akkadischen Texte. Sekundärliteratur in auswahl*. Berlin: Walter de Gruyter.

1978 *Assyrische-babylonische Zeichenliste*. Alter Orient und Altes Testament: Veröffentlichungen zur Kultur und Geschichte des Alten Orients und des Altes Testaments 33. Kevelaer: Verlag Butzon & Bercker.

Börker-Klähn, Jutta

1975 "Stele des Urnanše," in (ed.) Winfried Orthmann, *Der alte Orient*:188, Pl. 184 a-c. Propyläen Kunstgeschichte 18. Berlin: Propyläen Verlag.

1982 *Alt Vorderasiatische Bildstelen und vergleichbare Felsreliefs (2 Vols.)*. Deutsches Archäologisches Institute, Abteilung Baghdad: Baghdader Forschungen 4. Mainz am Rhein: Philipp von Zabern.

Bornstein, Marc H.

1975 "The Influence of Visual Perception on Culture." *American Anthropologist* 77:774-797.

Bottéro, Jean

1991 "Religion," in (ed.) Barthel Hrouda, *Der alte Orient: Geschichte und Kultur des alten Vorderasien*:217-246. Munich: C. Bertelsmann.

Bottéro, Jean, Elena Cassin, and Jean Vercoutter, (eds.)

1967 *The Near East: The early civilizations*. London: Weidenfeld and Nicholson.

Bottéro, Jean, and Samuel Noah Kramer

1989 *Lorsque les dieux faisaient l'homme: mythologie mésopotamienne*. Bibliothèque des histoires. Paris: Gaillimard.

Boyer, Pascal

1994a "Cognitive Constraints on Cultural Representations: Natural ontologies and religious ideas," in (eds.) Lawrence A. Hirschfeld and Susan A. Gelman, *Mapping the Mind: Domain specificity in cognition and culture*:391-411. Cambridge: Cambridge University Press.

1994b *The Naturalness of Religious Ideas: A cognitive theory of religion*. Berkeley: University of California Press.

1996 "Cognitive Limits to Conceptual Relativity: The limiting case of religious ontologies," in (eds.) John J. Gumperz and Stephen C. Levinson, *Intra-Speaker Relativity*:203-224. *Studies in the Social and Cultural Foundations of Language* 17. Cambridge: Cambridge University Press.

2000 "Evolution of the Modern Mind and the Origins of Culture: Religious concepts as limiting case," in (eds.) Peter Carruthers and Andrew Chamberlain, *Evolution and the Human Mind: Modularity. language and meta-cognition*:93-112. Cambridge: Cambridge University Press.

Braidwood, Robert, and Linda S. Braidwood

1960 *Excavations on the Plain of Antioch I, The Earlier Assemblages A-J*. Oriental Institute Publication 61. Chicago: Oriental Institute.

Brandes, Mark A.

1967 "Supraporten und Horizontalfries aus Stiftmosaiken der Pfeilerhall der Schicht IVa in Uruk-Warka," in (ed.) Dietz Otto Edzard, *Heidelberger Studien zum Alten Orient: Adam Falkenstein zum 17. September 1966*. Heidelberger Studien zum Alten Orient. Wiesbaden: Otto Harrasowitz.

1968 *Untersuchungen zur Komposition der Stiftmosaiken an der Pfeilerhalle der Schicht IVa in Uruk-Warka*. Baghdader Mitteilungen, Beiheft 1. Berlin: Gebr. Mann.

1979 *Siegelabrollungen aus den archaischen Bauschichten in Uruk-Warka* (2 Vols.). Freiburger Altorientalische Studien 2. Wiesbaden: Franz Steiner Verlag GmbH.

1980 "Modelage et impremerie aux débuts de l'écriture en Mésopotamie." *Akkadica* 18, 1-30.

Braun, Jan, Krystyna Lyczkowska, Maciej Popko, *et. al.*, (eds.)

1998 *Written on Clay and Stone: Ancient Near Eastern studies presented to Krystyna Szarzyńska on the occasion of her 80th Birthday*. Warsaw: Agade.

Braun-Holzinger, Eva Andrea

1977 *Frühdynastische Beterstatuetten*. Abhandlungen der Deutschen Orient-Gesellschaft 19. Berlin: Gebr. Mann Verlag.

1987 "Löwenadler," in (ed.) Dietz Otto Edzard, *Reallexikon der Assyriologie (Siebter Band)*:94-97. Berlin und New York: Walter de Gruyter.

1991 *Mesopotamische Weigaben der frühdynastischen bis altbabylonischen zeit*. Heidelberger Studien zum Alten Orient 3. Heidelberg: Heidelberger Orientverlag.

1998-2001 "Ninurta/Ningirsu B. In der Bildkunst," in (ed.) D. O. Edzard, *Reallexikon der Assyriologie (Neunter Band)*:522-524. Berlin: Walter de Gruyter.

Breton, Louis le

1957 "The Early Periods at Susa, Mesopotamian Relations." *Iraq* 19, 2:79-124.

Brewer, Douglas J., and Robert J. Wenke

1992 "Transitional Late Predynastic - Early Dynastic Occupations at Mendes: A preliminary report," in (ed.) Edwin C. M. van den Brink, *The Nile Delta in Transition: 4th - 3rd Millennium B.C.. Proceedings of a Seminar Held in Cairo, 21. - 24 October 1990, at the Netherlands Institute of Archaeology and Arabic Studies*:191-299. Tel Aviv: Distributed by the Israel Exploration Society for Edwin C. M. van den Brink.

- Brewer, William F.  
1999 "Schemata," in (eds.) Robert A. Wilson and Frank C. Keil, *The MIT Encyclopedia of the Cognitive Sciences*:729-730. A Bradford Book. Cambridge, Massachusetts: MIT Press.
- Brilliant, Richard  
1984 *Visual Narratives: Storytelling in Etruscan and Roman art*. Ithaca: Cornell University Press.
- Brink, Edwin C. M. van den, (ed.)  
1988 *The Archaeology of the Nile Delta, Egypt: Problems and priorities. Proceedings of the Seminar held in Cairo, 19 - 22 October 1986, on the Occasion of the Fifteenth Anniversary of the Netherlands Institute of Archaeology and Arabic Studies in Cairo*. Amsterdam: Netherlands Foundation for Archaeological Research in Egypt.  
1992 *The Nile Delta in Transition: 4th - 3rd Millennium B.C.. Proceedings of a Seminar Held in Cairo, 21. - 24 October 1990, at the Netherlands Institute of Archaeology and Arabic Studies*. Tel Aviv: Distributed by the Israel Exploration Society for Edwin C. M. van den Brink.
- Brown, Cecil  
1984 *Language and Living Things: Uniformities in folk classification and naming*. New Brunswick, New Jersey: Rutgers University Press.
- Brun, Alain le  
1971 "Recherches stratigraphiques à l'acropole de Suse, 1969-1971." *Cahiers de la Délégation Archéologique Française en Iran* 1.
- Brun, Alain le, and François Vallat  
1978 "L'origine de l'écriture à Suse." *Cahiers de la Délégation Archéologique Française en Iran* 8:11-59.
- Brunton, G., and G. Caton-Thompson  
1928 *The Badarian Civilization and Predynastic Remains Near Badari*. British School of Archaeology in Egypt and Egyptian Research Account 46. London: Bernard Quaritch.
- Buccellati, Giorgio, and Robert D. Biggs  
1969 *Cuneiform texts from Nippur: The eighth and ninth seasons*. Assyriological Studies 17. Chicago: University of Chicago Press.
- Buchanan, Briggs  
1966 *Catalogue of Ancient Near Eastern Seals in the Ashmolean Museum. Volume I: Cylinder seals*. Oxford: Clarendon Press.  
1967 "The Prehistoric Stamp Seal: A reconsideration of some old excavations (part I)." *Journal of the American Oriental Society* 87:265-279.  
1967 "The Prehistoric Stamp Seal: A reconsideration of some old excavations (part II)." *Journal of the American Oriental Society* 87:525-540.
- Budge, E. A. Wallis  
1925 *The Rise and Progress of Assyriology*. London: Martin Hopkinson.

Buren, E. Douglas van

- 1930-1941 "Religious Rites and Ritual in the Time of Uruk IV-III." *Archiv für Orientforschung* 13:32-45.
- 1931 *Foundation Figurines and Offerings*. Berlin: H. Schoetz & Co
- 1933 *The Flowing Vase and the God with Streams*. Berlin: H. Schoetz.
- 1939 *The Fauna of Ancient Mesopotamia as Represented in Art*. *Analecta Orientalia* 18. Rome: Pontificum, Institutum Biblicum.
- 1944 "The Sacred Marriage in Early Times in Mesopotamia." *Orientalia, Nova Series* 13:1-72.
- 1945 *Symbols of the Gods in Mesopotamian Art*. *Analecta Orientalia* 23. Rome: Pontificum, Institutum Biblicum.

Burkholder, Grace

- 1972 "Ubaid Sites and Pottery in Saudi Arabia." *Archaeology* 25:264-269.

Burrows, Eric

- 1935 *Ur Excavations, Texts (Vol. 2)*. *Archaic Texts*. Publications of the Joint Expedition of the British Museum and of the Museum of the University of Pennsylvania to Mesopotamia. London: Harrison and Sons Limited.

Byrne, Richard W., and Andrew Whiten, (eds.)

- 1988 *Machiavellian Intelligence: Social expertise and the evolution of intellect in monkeys, apes, and humans*. Oxford: Clarendon Press.

Calvin, William H.

- 1996 *The Cerebral Code: Thinking a thought in the mosaics of the mind*. Cambridge, Massachusetts: MIT Press.

Calwell, D. H.

- 1976 "The Early Glyptic of Gawra, Giyan and Susa and the Development of Long Distance Trade." *Orientalia, Nova Series* 45:227-250.

Cann, Rebecca L., Mark Stoneking, and Allan C. Wilson

- 1987 "Mitochondrial DNA and Human Evolution." *Nature* 325:31-36.

Canby, Jeanny Vorys

- 2001 *The Ur-Nammu Stela*. University Museum Monograph 110. Philadelphia: University of Pennsylvania Museum of Archaeology and Anthropology.

Capart, Jean

- 1905 *Primitive Art in Egypt*. (ed.) A. S. Griffith. Philadelphia: J. B. Lippincott Company.

Carey, Susan, and Elizabeth S. Spelke

- 1994 "Domain-Specific Knowledge and Conceptual Change," in (eds.) Lawrence A. Hirschfeld and Susan A. Gelman, *Mapping the Mind: Domain specificity in cognition and culture*:169-200. Cambridge: Cambridge University Press.

Carruthers, Peter, and Andrew Chamberlain, (eds.)

- 2000 *Evolution and the Human Mind: Modularity, language and meta-cognition*. Cambridge: Cambridge University Press.

Casanova, Michèle

1995 "Le lapis-lazuli dans l'Orient antique," in (ed.) Françoise Tallon, *Les pierres précieuses de l'Orient ancien: Des Sumériens aux Sassanides*:15-20. Les dossiers du musée du Louvre; Exposition-dossier du département des Antiquités orientales 49. Paris: Editions de la Réunion ds musées nationaux.

Case, Humphrey, and Joan Crowfoot Payne

1962 "Tomb 100: The decorated tomb at Hierakonpolis." *Journal of Egyptian Archaeology* 48:5-18.

Caspers, Elizabeth C. L. During

1971 "New Archaeological Evidence for Maritime Trade in the Persian Gulf During the Late Protoliterate Period." *East and West* 21:21-44.

Caubet, Annie, and Marthe Bernus-Taylor

1991 *The Louvre: Near Eastern antiquities*. London: Scala Books.

Charvát, Petr

1986 "The Name Anzu-d-Sùd in the Texts from Fara," in (eds.) Karl Hecker and Walter Sommerfeld, *Keilschriftliche Literaturen. Ausgewählte Vorträge der XXXII. Rencontre Assyriologique Internationale Münster, 8- 12.7.1985*:45-53. Berliner Beiträge zum Vordern Orient 6. Berlin.

Chauvet, Jean-Marie, Eliette Brunel Deschamps, and Christian Hillaire

1996 *Dawn of Art: The Chauvet Cave. The Oldest Known Paintings in the World*. New York: Harry N. Abrams.

Chiera, Edward

1916a *Lists of personal names from the Temple school of Nippur: Lists of Akkadian personal names*. Publications of the Babylonian Section 11, 2. Philadelphia: University Museum, University of Pennsylvania.

1916b *Lists of personal names from the Temple school of Nippur: Lists of Sumerian personal names*. Publications of the Babylonian Section 11, 3. Philadelphia: University Museum, University of Pennsylvania.

Chlodnicki, M., R. Fattovich, and S. Salvatori

1992 "The Nile Delta in Transition: A view from Tell El-Farkha," in (ed.) Edwin C. M. van den Brink, *The Nile Delta in Transition: 4th - 3rd Millennium B.C.. Proceedings of a Seminar Held in Cairo, 21. - 24 October 1990, at the Netherlands Institute of Archaeology and Arabic Studies*:171-190. Tel Aviv: Distributed by the Israel Exploration Society for Edwin C. M. van den Brink.

Chomsky, Noam

1972 *Language and Mind (enlarged ed.)*. New York: Harcourt Brace Jovanovich.

1979 *Language and Responsibility (Based on Conversations With Mitsou Ronat)*. Translated by John Viertel. Sussex: Harvester Press.

1980 *Rules and Representations*. Woodbridge Lectures 11. New York: Columbia University Press.

1986 *Knowledge of Language: Its nature, origin, and use*. Convergence. Westport: Praeger.

1988 *Language and Problems of Knowledge and Freedom: The Managua lectures.* Cambridge, Massachusetts: MIT Press.

Christian, Victor

1940 *Alttertumskunde des Zweistromlandes von der vorzeit bis zum ende der Achämenidenherrschaft.* Leipzig: Karl W. Hiersemann.

Christiana, Köhler

1992 "The Pre- and Early Dynastic Pottery of Tell El-Fara'in (Buto)," in (ed.) Edwin C. M. van den Brink, *The Nile Delta in Transition: 4th - 3rd Millennium B.C.. Proceedings of a Seminar Held in Cairo, 21. - 24 October 1990, at the Netherlands Institute of Archaeology and Arabic Studies:*11-22. Tel Aviv: Distributed by the Israel Exploration Society for Edwin C. M. van den Brink.

Churcher, C. S.

1984 "Zoological Study of the Ivory Knife Handle From Abu Zaidan," in (ed.) W. Needler, *Predynastic and Archaic Egypt in the Brooklyn Museum.* Wilbour Monographs 9. New York.

Churchland, Paul M.

1996 *The Engine of Reason the Seat of the Soul: A philosophical journey into the brain.* Cambridge, Massachusetts: MIT Press.

Churchland, Patricia Smith, and Terrence J. Sejnowski

1992 *The Computational Brain.* A Bradford Book. Cambridge, Massachusetts: MIT Press.

Ciałowicz, Krzysztof M.

1987 *Les tetes massues des périodes prédynastique et archaïque dans la Vallée du Nil.* Archeologii Sróziemnomorskiej 9. Krakow: Nakladem Uniwerstetu Jagiellonskiego.

1991 *Les palettes égyptiennes aux motifs zoomorphes et sans décoration: études de l'art prédynastique.* Studies in Ancient Art and Civilization 3. Krakow: Uniwersytet Jagiellonski.

1992 "La composition, le sens et la symbolique des scènes zoomorphes prédynastiques en relief. Les manches de couteaux," in (eds.) Renée F. Friedman and Barbara Adams, *The Followers of Horus: Studies dedicated to Michael Allen Hoffman 1944-1990:*247-258. Egyptian Studies Association Publication 2. Oxbow Monograph 20. Oxford: Oxbow Books.

Civil, Miguel

1966 "UET 6/1 no. 2." *Revue d'assyriologie et d'archéologie orientale* 60:92.

1972a "Review of *Das Lugalbandaepos* by Claus Wilcke." *Journal of Near Eastern Studies* 31, 4:385-387.

1972b "The Anzu Bird and Scribal Whimsies." *Journal of the American Oriental Society* 92:721.

1975 "Lexicography," in (ed.) Stephen J. Lieberman, *Sumerological Studies in Honor of Thorkild Jacobsen on His Seventieth Birthday: June 7, 1974:*123-158. Assyriological Studies 20. Chicago: University of Chicago Press.

1994 "Sumerian," in (ed.) Giulio Lepschy, *History of Linguistics (Volume I): The Eastern Traditions of Linguistics.* Longman Linguistics Library. London: Longman.

- 1997 "Sumerian," in (ed.) Eric M. Meyers, *The Oxford Encyclopedia of Archaeology in the Near East (Vol. 5)*:92-95. New York: Oxford University Press.
- Clanchy, M. T.  
1993 *From Memory to Written Record: England 1066-1307*. Oxford: Blackwell.
- Clark, J. Desmond  
1971 "A Re-Examination of the Evidence for Agricultural Origins in the Nile Valley." *Proceedings of the Prehistoric Society* 37:34-79.
- Clay, A. T.  
1915 *Miscellaneous Inscriptions in the Yale Babylonian Collection*. Yale Oriental Series. Babylonian Texts 1. New Haven: Yale University Press.
- Clottes, Jean, and Jean Courtin  
1996 *The Dawn of Art. The Chauvet Cave: The earliest known paintings in the world*. Translated by Marilyn Garner. New York: Harry N. Abrams.  
1996 *The Cave Beneath the Sea: Paleolithic images at Cosquer*. New York: H. N. Abrams.
- Clottes, Jean, and David Lewis-Williams  
1996 *Les chamanes de la préhistoire: Transe et magie dans les grottes ornées*. Arts rupestres. Paris: Seuil.
- Coe, Michael  
1992 *Breaking the Maya Code*. New York: Thames and Hudson.
- Cohen, Mark E.  
1993 *The Cultic Calendars of the Ancient Near East*. Bethesda, Maryland: CDL Press.
- Cohen, Sol  
1972 *Enmerkar and the Lord of Aratta*. Ph.D. dissertation, University of Pennsylvania.
- Cole, Michael, Yrjö Engström, and Olga Vasquez, (eds.)  
1997 *Mind, Culture, and Activity: Seminal papers from the Laboratory of Comparative Human Cognition*. Cambridge: Cambridge University Press.
- Collon, Dominique  
1982 *Catalogue of the Western Asiatic Seals in the British Museum. Cylinder Seals II: Akkadian, Post Akkadian, Ur III*. London: Published for the Trustees of the British Museum by British Museum Publications Ltd.  
1987 *First Impressions: Cylinder seals in the ancient Near East*. Chicago: University of Chicago Press.
- Comrie, Bernard  
1989 *Language Universals & Linguistic Typology (2nd ed.)*. Chicago: University of Chicago Press.
- Connan, Jacques, and Odile Deschesne  
1996 *Le bitume à Suse: Collection du Musée du Louvre*. Paris: Réunion des musées nationaux.

## Conteneau, Georges

- 1927 *Manuel d'archéologie orientale depuis les origins jusqu'a l'époque d'Alexandre. Notions générales (Races, chronologie, langage, écriture, religion, etc.... Histoire de l'art (Art archaïque d'Elam et de Sumer): Tome I.* Paris: Éditions Auguste Picard.
- 1931 *Manuel d'archéologie orientale depuis les origins jusqu'a l'époque d'Alexandre. Histoire de l'art (suite) IIIe et IIe Millénaires avant notre ère: Tome II.* Paris: Éditions Auguste Picard.
- 1934 *Monuments Mésopotamiens nouvellement acquis ou peu connus (Musée du Louvre).* Paris: Les Éditions d'Art et d'Histoire.
- 1947 *Manuel d'archéologie orientale depuis les origins jusqu'a l'époque d'Alexandre. Les découvertes archéologiques de 1930 a 1939: Tome IV.* Paris: Éditions Auguste Picard.
- n. d. *Musée du Louvre. Les antiquités orientales: Sumer, Babylonie, Élam. Documents d'art.* Paris: Éditions Albert Morance.

## Cook, V. J., and Mark Newson

- 1997 *Chomsky's Universal Grammar: An introduction.* Second ed. Oxford: Blackwell Publishers.

## Cooper, Jerrold S.

- 1972 "Review of *Foundation Deposits in Ancient Mesopotamia* by Richard Ellis." *Journal of Near Eastern Studies* 31, 3:207-209.
- 1973 "Sumerian and Akkadian in Sumer and Akkad." *Orientalia, Nova Series* 42:239-246.
- 1978 *The Return of Ninurta to Nippur.* *Analecta Orientalia* 52. Rome: Pontificum Institutum Biblicum.
- 1980 "Studies in Mesopotamian Lapidary Inscriptions." *Revue d'assyriologie et d'archéologie orientale* 74:101-109.
- 1983 *Reconstructing History From Ancient Inscriptions: The Lagash-Umma border conflict.* *Sources From The Ancient Near East* 2 (1). Malibu: Undena.
- 1986 *Sumerian and Akkadian Royal Inscriptions, I: Presargonic inscriptions.* The American Oriental Society Translation Series 1. New Haven: American Oriental Society.
- 1990 "Mesopotamian Historical Consciousness and the Production of Monumental Art in the Third Millennium B. C.," in (ed.) Ann C. Gunter, *Investigating Artistic Environments in the Ancient Near East*:39-52. Sackler Gallery. Washington.
- 1993 "Sacred Marriage and Popular Cult in Early Mesopotamia," in (ed.) Eiko Matsushima, *Official Cult and Popular Religion in the Ancient Near East. Papers of the First Colloquium on the Ancient Near East- The City and its Life Held at The Middle Eastern Culture Center in Japan (Mitaka, Tokyo) March 20-22, 1992*:81-96. Heidelberg: Universitätsverlag C. Winter.

## Cooper, Jerrold S., and Glenn M. Schwartz, (eds.)

- 1996 *The Study of the Ancient Near East in the Twenty First Century: The William Foxwell Albright Centennial Conference.* Winona Lake, Indiana: Eisenbrauns.

## Corballis, Michael C.

- 1991 *The Lopsided Ape: Evolution of the generative mind.* Oxford: Oxford University Press.
- 1994 "Discussion. The Generation of Generativity: A response to Bloom." *Cognition* 51:191-198.

## Cosmides, Leda, and John Tooby

1992 "Cognitive Adaptations for Social Exchange," in (eds.) Jerome H. Barkow, Leda Cosmides, and John Tooby, *The Adapted Mind: Evolutionary psychology and the generation of culture*:163-228. Oxford: Oxford University Press.

1994 "Origins of Domain Specificity: The evolution of functional organization," in (eds.) Lawrence A. Hirschfeld and Susan A. Gelman, *Mapping the Mind: Domain specificity in cognition and culture*:85-116. Cambridge: Cambridge University Press.

## Crawford, Harriet

1973 "Mesopotamia's Invisible Exports in the Third Millennium." *World Archaeology* 5, 2:232-241.

1985 "A Note on the Vegetation on the Uruk Vase." *Bulletin on Sumerian Agriculture* 2:72-76.

1987 "The 'Construction Inférieure' at Tello: A reassessment." *Iraq* 49:71-76.

## Crawford, Vaughn

1962 "Nippur: The holy city." *Archaeology* 12.

1972 "Excavations in the Swamps of Sumer." *Expedition* 14, 2:12-20.

1974 "Lagash." *Iraq* 36:29-35.

1977 "Inscriptions from Lagash, Season Four, 1975-1976." *Journal of Cuneiform Studies* 29:189-222.

## Cros, Gaston

1904 "Mission Française de Chaldée: Campagne de 1903. Compte rendu sommaire des fouilles." *Revue d'assyriologie et d'archéologie orientale* 6, 1:5-16.

1906 "Note rectificative sur le casque Chaldéen de Tello." *Revue d'assyriologie et d'archéologie orientale* 4, 3:88-89.

1910-1914 *Nouvelles fouilles de Tello*. Paris: E. Leroux.

## Cross, Frank Moore

1989 "The Invention and Development of the Alphabet," in (ed.) Wayne M. Senner, *The Origins of Writing*:77-90. Lincoln, Nebraska: University of Nebraska Press.

## Crystal, David

1991 (3rd ed.) *A Dictionary of Linguistics and Phonetics*. Oxford: Blackwell.

## Cunningham, Graham

1997 *'Deliver Me From Evil': Mesopotamian incantations 2500-1500 BC*. Studia Pohl: Series Maior 17. Rome: Biblical Institute Press.

## Curtis, John, (ed.)

1993 *Early Mesopotamia and Iran: Contact and Conflict c. 3500-1600 BC. Proceedings of a seminar in memory of Vladimir G. Lukonin*. London: British Museum Press.

## D'Errico, Francesco

1995 "A New Model and Its Implications for the Origin of Writing: The La Marche antler revisited." *Cambridge Archaeological Journal* 5, 2:163-206.

1999 "Palaeolithic Origins of Artificial Memory Systems: An evolutionary perspective," in (eds.) Colin Renfrew and Chris Scarre, *Cognition and Material Culture: The archaeology of symbolic storage*:19-50. McDonald Institute Monographs. Cambridge: McDonald Institute for Archaeological Research.

Damerow, Peter

1988 "Individual Development and Cultural Evolution of Arithmetical Thinking," in (ed.) Sidney Strauss, *Ontogeny, Phylogeny and Historical Development*:125-153. Human Development 2. Norwood, N.J.: Ablex Publishing Corporation.

1996 *Abstraction and Representation: Essays on the cultural evolution of thinking*. Boston Studies in the Philosophy of Science 175. Dordrecht: Kluwer Academic Publishers.

Davies, Whitney V

1976 "The Origins of the Register Composition in Predynastic Egyptian Art." *Journal of the American Oriental Society* 96:404-418.

1981 "The Foreign Relations of Predynastic Egypt: Palestine in the predynastic period." *Journal of the Society for the Study of Egyptian Antiquities* 11, 1:22-.

1983 "Cemetery T at Nagada." *Mitteilungen des Deutschen Archäologischen Instituts, Abteilung Kairo* 39:17-28.

1990 "Egyptian Hieroglyphs," in (ed.) J. T. Hooker, *Reading the Past: Ancient writing from cuneiform to the alphabet*:75-137. Berkeley: University of California Press.

1992 *Masking the Blow: The scene of representation in late prehistoric Egyptian art*. Berkeley: University of California Press.

Davis, Richard H.

1997 *Lives of Indian Images*. Princeton: Princeton University Press.

Dawkins, Richard

1989 *The Selfish Gene (New Edition)*. Oxford: Oxford University Press.

De Cardi, B., (ed.)

1978 *Qatar Archaeological Reports: Excavations 1973*. Oxford: Oxford University Press.

Deacon, Terrence W.

1992 "Brain-Language Coevolution," in (eds.) John A. Hawkins and Murray Gell-Mann, *The Evolution of Human Languages : Proceedings of the Workshop on the Evolution of Human Languages, Held August 1989 in Santa Fe, New Mexico*:49-83. Santa Fe Institute; Studies in the Sciences of Complexity. Proceedings 11. Redwood City: Addison-Wesley.

1997 *The Symbolic Species: The co-evolution of language and brain*. New York: W. W. Norton and Company.

DeFrancis, John

1984 *The Chinese Language: Fact and Fantasy*. Honolulu: University of Hawaii Press.

1989 *Visible Speech: The diverse oneness of writing systems*. Honolulu: University of Hawaii Press.

Deimel, Anton

- 1920 "Die Listen über den Ahnenkult aus der Zeit Lugalandas und Urukaginas." *Orientalia, Nova Series* 2:32-51.
- 1928-1933 *Sumerisches Lexikon II: vollständige Ideogramm-Sammlung* (4 Vols.). Scripta Pontificii Instituti Biblici. Rom: Verlag des Päpstlichen Bibelinstituts.
- 1931 *Sumerische Tempelwirtschaft zur Zeit Urukaginas und seiner Vorgänger. Abschluss der Einzelstudien und Zusammenfassung der Hauptresultate.* Analecta Orientalia 2. Rome: Pontificio Instituto Biblico 2.
- 1934 *Sumerisches Lexikon III/1: sumerisch-Akkadisches glossar.* Scripta Pontificii Instituti Biblici. Rome: Verlag des Päpstlichen Bibelinstituts.
- 1937 *Sumerisches Lexikon III/2: Akkadisch-sumerisches glossar.* Scripta Pontificii Instituti Biblici. Rome: Verlag des Päpstlichen Bibelinstituts.
- 1947 *Sumerisches Lexikon I: Sumerische, Akkadische und hethitische Lautwerte nach Keilschriftzeichen und Alphabet.* Scripta Pontificii Instituti Biblici. Rome: Verlag des Päpstlichen Bibelinstituts.

Delaporte, Louis

- 1920 *Musée du Louvre, Catalogue des cylindres orientaux, cachets, et pierres gravées de style oriental. I Fouilles et Missions.* Fondation de Clerq et Fondation Dourlans. Paris: Hachette.

Delougaz, Pinhas

- 1933 *I. Plano-Convex Bricks and the Methods of their Employment. II. The Treatment of Clay Tablets in the Field.* Studies in Ancient Oriental Civilization 7. Chicago: University of Chicago Press.
- 1940 *The Temple Oval at Khafajah.* Oriental Institute Publications 53. Chicago: University of Chicago Press.
- 1952 *Pottery from the Diyala Region.* Oriental Institute Publications 63. Chicago: University of Chicago Press.
- 1960 "Architectural Representations on Steatite Vases." *Iraq* 22:90-95.

Delougaz, Pinhas, and Helene J. Kantor

- 1972 "New Evidence for the Prehistoric & Protoliterate Culture Development of Khuzestan," *VIth International Congress of Iranian Art & Archaeology.* Tehran: Offset Press Inc.
- 1996 *Choga Mish. Volume I: The first five seasons of Excavations 1961-1971* (2 Vols.). Oriental Institute Publications 101. Chicago: University of Chicago Press.

Delougaz, Pinhas, and Seton Lloyd

- 1942 *Pre-Sargonid Temples in the Diyala Region.* Oriental Institute Publications 58. Chicago: University of Chicago Press.

Dennett, Daniel C.

- 1995 *Darwin's Dangerous Idea: Evolution and the meanings of life.* New York: Simon & Schuster.

Dent, Cathy H.

- 1987 "Developmental Studies of Perception and Metaphor: The twain shall meet." *Metaphor and Symbolic Activity* 2, 1:53-71.

Dhorme, P.

1909 "Les plus anciens noms de personnes à Lagaš." *Zeitschrift für Assyriologie und Vorderasiatische Archäologie* 22:284-316.

Diakonoff, I. M.

1969 *Ancient Mesopotamia: Socio-economic history*. Liechtenstein: Sandig Reprint Verlag.

1972-1975 "General Outline of the First Period of the History of the Ancient World and the Problem of the Ways of Development," in (ed.) I. M. Diakonoff, *Early Antiquity*:26-66. Chicago: University of Chicago Press.

1974 *Structure of Society and State in Early Dynastic Sumer*. Monographs on the Ancient Near East 1 (3). Malibu: Undena.

1982 "The Structure of Near Eastern Society Before the Middle of the 2nd Millennium B.C." *Oikumene: Studia ad historiam classicam et orientalem spectantia* 3:7-100.

1990 "The Rise of the Despotic State in Ancient Mesopotamia," in (ed.) I. M. Diakonoff, *Ancient Mesopotamia: Socio-economic history, a collection of studies by Soviet scholars*:173-203. Vaduz, Liechtenstein: USSR Academy of Sciences, Institute of the Peoples of Asia.

1991a *Early Antiquity*. Chicago: University of Chicago Press.

1991b "The City-States of Sumer," in (ed.) I. M. Diakonoff, *Early Antiquity*:27-67. Chicago: University of Chicago Press.

1991c "Early Despotisms in Mesopotamia," in (ed.) I. M. Diakonoff, *Early Antiquity*:67-84: University of Chicago Press.

Dick, Michael Brennan, (ed.)

1999 *Born in Heaven, Made on Earth: The making of the cult image in the ancient Near East*. Winona Lake: Eisenbrauns.

Dijk, J. J. A. van

1983 *LUGAL UD ME-LÁM-bi NIR-ĜÁL: Le récit épique et didactique des Travaux de Ninurta, du Déluge et de la Nouvelle Création (2 Vols.)*. Leiden: E. J. Brill.

Dolce, Rita

1978 *Gli intarsi mesopotamici dell'epoca protodynastica*. Serie archaeologica 23. Rome: Istituto di studi del Vicino Oriente; Università.

1997 "Aux origines de la royauté à Tello." *Akkadica* 103:1-5.

Donald, Merlin

1991 *Origins of the Modern Mind. Three Stages in the Evolution of Culture and Cognition*. Cambridge, Massachusetts: Harvard University.

1993 "Précis of Origins of the Modern Mind: Three stages in the evolution of culture and cognition." *Behavioral and Brain Sciences* 16:737-791.

1999a "Hominid Enculturation and Cognitive Evolution," in (eds.) Colin Renfrew and Chris Scarre, *Cognition and Material Culture: The archaeology of symbolic storage*:7-18. McDonald Institute Monographs. Cambridge: McDonald Institute for Archaeological Research.

1999b "Material Culture and Cognition: Concluding thoughts," in (eds.) Colin Renfrew and Chris Scarre, *Cognition and Material Culture: The archaeology of symbolic storage*:181-187. McDonald Institute Monographs. Cambridge: McDonald Institute for Archaeological Research.

- 2001 *A Mind So Rare: The evolution of human consciousness*. New York: W.W. Norton
- Donbaz, V., and William W. Hallo  
1976 "Monumental Texts From Pre-Sargonic Lagash." *Oriens Antiquus* 15:1-9.
- Dowson, Thomas A.  
1999 "Rock Art: Handmaiden to studies of cognitive evolution," in (eds.) Colin Renfrew and Chris Scarre, *Cognition and Material Culture: The archaeology of symbolic storage*:67-76. McDonald Institute Monographs. Cambridge: McDonald Institute for Archaeological Research.
- Dreyer, Günter  
1986 *Elephantine VIII: Der Tempel der Satet. Die Funde der Frühzeit und des alten Reiches*. Archäologische Veröffentlichung 39. Mainz am Rhein: Philipp von Zabern.  
1992a "Horus Krokodil ein Gegenkönig der Dynastie 0," in (eds.) Renée F. Friedman and Barbara Adams, *The Followers of Horus: Studies dedicated to Michael Allen Hoffman 1944-1990*:259-261. Egyptian Studies Association Publication 2; Oxbow Monograph 20. Oxford: Oxbow Books.  
1992b "Recent Discoveries at Abydos Cemetery U," in (ed.) Edwin C. M. van den Brink, *The Nile Delta in Transition: 4th - 3rd Millennium B.C.. Proceedings of a Seminar Held in Cairo, 21. - 24 October 1990, at the Netherlands Institute of Archaeology and Arabic Studies*:293-300. Tel Aviv: Distributed by the Israel Exploration Society for Edwin C. M. van den Brink.
- Dreyer, Günter , Angela von den Dreisch, and Stefan Klug  
1990 "Umm el-Qaab: Nachuntersuchungen im frühzeitlichen Königsfriedhof. 3./4. Vorbericht." *Mitteilungen des Deutschen Archäologischen Instituts, Abteilung Kairo* 46:53-90.
- Dreyer, Günter, Eva-Maria Engel, Ulrich Hartung, *et. al.*  
1996 "Umm el-Qaab: Nachuntersuchungen im frühzeitlichen Königsfriedhof. 7./8. Vorbericht." *Mitteilungen des Deutschen Archäologischen Instituts, Abteilung Kairo* 52:11-81.
- Dreyer, Günter , Ulrich Hartung, and Frauke Pumpenmeier  
1993 "Umm el-Qaab: Nachuntersuchungen im frühzeitlichen Königsfriedhof. 5./6. Vorbericht." *Mitteilungen des Deutschen Archäologischen Instituts, Abteilung Kairo* 49:23-62.  
1998 *Umm el-Qaab I: Das prädynastische Königsgrab U-j und seine frühen Schriftzeugnisse*. Archäologische Veröffentlichungen (Deutsches Archäologisches Institut. Abteilung Kairo) 86. Mainz: Philipp von Zabern.
- Dunbar, Robin  
1996 *Grooming, Gossip and the Evolution of Language*. Cambridge, Massachusetts: Harvard University Press.  
2000 "On the Origin of the Human Mind," in (eds.) Peter Carruthers and Andrew Chamberlain, *Evolution and the Human Mind: Modularity. language and meta-cognition*:238-253. Cambridge: Cambridge University Press.

- Dunham, Sally  
1980 *A Study of Ancient Mesopotamian Foundations*. Ph.D. dissertation, Columbia University.
- Ebeling, Erich  
1928-1929 "Talim." *Archiv für Orientforschung* 5:218-219.
- Ebeling, Erich, Bruno Meissner, Ernst F. Weidner, *et. al.*  
1928-present *Reallexikon der Assyriologie*. Berlin: Walter de Gruyter.
- Eco, Umberto, Marco Santambrogio, and Patrizia Violi, (eds.)  
1988 *Meaning and Mental Representations*. Bloomington: University of Indiana Press.
- Edwards, I. E. S.  
1990 [1971] "The Early Dynastic Period in Egypt," in (eds.) I. E. S. Edwards, C. J. Gadd, and N. G. L. Hammond, *The Cambridge Ancient History (Vol. 1, Part 2)*:1-70. Cambridge: Cambridge University Press.
- Edwards, I. E. S., C. J. Gadd, and N. G. L. Hammond, (eds.)  
1990 [1971] *The Cambridge Ancient History (Vol. 1, Part 2)*. Cambridge: Cambridge University Press.
- Edzard, Dietz Otto  
1957-1971 "Gu'edena," in (ed.) Dietz Otto Edzard, *Reallexikon der Assyriologie (Dritter Band)*:687-688. Berlin und New York: Walter de Gruyter.  
1965 "Mesopotamien. Die Mythologie der Sumerer und Akkader," in (ed.) Hans Wilhelm Haussig, *Götter und Mythen in Vordern Orient. Die Alten Kulturvölker* 1. Stuttgart.  
1967a "The Early Dynastic Period," in (eds.) Jean Bottéro, Elena Cassin, and Jean Vercoutter, *The Near East: The early civilizations*:52-90. London: Weidenfeld and Nicholson.  
1967b *Heidelberger Studien zum Alten Orient: Adam Falkenstein zum 17. September 1966*, Heidelberger Studien zum Alten Orient. Wiesbaden: Harrassowitz.  
1968 *Sumerische Rechtsurkunden des III. Jahrtausends aus der Zeit vor der III. Dynastie von Ur*. Veröffentlichungen der Kommission zur Erschliessung von Keilschrifttexten. Serie A; Stück 4. (ed.) Philosophisch-Historische Klasse I Bayerische Akademie der Wissenschaften, 67; Kommission zur Erschliessung von Keilschrifttexten. München: Verlag der Bayerischen Akademie der Wissenschaften.  
1972-1975 "Hursagkalama A. Philologisch," in (ed.) D. O. Edzard, *Reallexikon der Assyriologie (Vierter Band)*:519-520. Berlin: Walter de Gruyter.  
1974 "Problèmes de la royauté dans la période présargonique," in (ed.) Paul Garelli, *Le palais et la royauté (archéologie et civilisation)*:141-151. XIXe Rencontre Assyriologique Internationale 1971. P. Geuthner: Paris.  
1975 "Zum Sumerische Eid," in (ed.) Stephen J. Lieberman, *Sumerological Studies in Honor of Thorkild Jacobsen on His Seventieth Birthday: June 7, 1974*:63-98. Assyriological Studies 20. Chicago: University of Chicago Press.  
1976 "Kiš. B. Philologisch," in (ed.) D. O. Edzard, *Reallexikon der Assyriologie (Fünfter Band)*:607-613. Berlin: Walter de Gruyter.  
1991 "Geschichte," in (ed.) Barthel Hrouda, *Der alte Orient: Geschichte und Kultur des alten Vorderasien*:55-84. Munich: C. Bertelsmann.

- 1993 "Königslisten und Chroniken: A. Sumerisch," in (ed.) D. O. Edzard, *Reallexikon der Assyriologie (Sechster Band)*:77-86. Berlin: Walter de Gruyter.
- 1993-1997 "Mesilim (Mesalim). A. Philologisch.," in (ed.) D. O. Edzard, *Reallexikon der Assyriologie (Achter Band)*:74. Berlin: Walter de Gruyter.
- 1997a *Gudea and his Dynasty. The Royal Inscriptions of Mesopotamia: Early periods 3/1*. Toronto: University of Toronto Press.
- 1997b "The Names of Sumerian Temples," in (eds.) I. L. Finkel and M. J. Geller, *Sumerian Gods and Their Representations*:159-165. Cuneiform Monographs 7. Groningen: Styx.
- Edzard, Dietz Otto, and W. G. Lambert
- 1976 "Igalim(a)," in (ed.) Ernst and Wolfram von Soden Weidner, *Reallexikon der Assyriologie (Fünfter Band)*:483-495. Berlin und New York: Walter de Gruyter.
- Edzard, Dietz Otto, G. Farber, and Edmond Sollberger
- 1977 *Répertoire géographique des textes cunéiformes I. Die Orts- und Gewässernamen der prä-sargonischen und sargonischen Zeit*. Beihefte zum Tübinger Atlas des Vorderen Orients, Reihe B 7/1. Wiesbaden: Ludwig Reichert.
- Ehrich, Robert W., (ed.)
- 1965 *Chronologies in Old World Archaeology*. Chicago: University of Chicago Press.
- 1992 *Chronologies in Old World Archaeology (2 Vols.)*. Chicago: University of Chicago Press.
- Eichler, Barry L., Jane W. Meimerdinger, and Åke Sjöberg, (eds.)
- 1976 *Samuel Noah Kramer Anniversary Volume: Cuneiform studies in honor of Samuel Noah Kramer*, Alter Orient und Altes Testament Veröffentlichungen zur Kultur und Geschichte des Alten Orients und des Alten Testaments 25. Kevelaer: Verlag Butzon & Bercker.
- Eichmann, Ricardo
- 1989 *Uruk - Die Stratigraphie: Grabungen 1912-1977 in den bereichen 'Eanna' und 'Anu-Ziggurat' (2 Vols.)*. Ausgrabungen in Uruk-Warka: Endberichte 3. Deutsches Archäologisches Institut, Abteilung Baghdad. (ed.) R. M. Boehmer. Mainz am Rhein: Philipp von Zabern.
- Eliot, H.W.
- 1950 *Excavations in Mesopotamia and Western Iran. Sites of 4000-500 B.C.* Special Publication of the Peabody Museum of American Archaeology and Ethnology. Cambridge: The Peabody Museum.
- Ellen, Roy F.
- 1993 *The Cultural Relations of Classification: An Analysis of Nuaulu Animal Categories from Central Seram*. Cambridge Studies in Social and Cultural Anthropology 91. Cambridge: Cambridge University Press.
- Ellis, Richard S.
- 1968 *Foundation Deposits in Ancient Mesopotamia*. Yale Near Eastern Researches 2. New Haven: Yale University Press.
- 1972 *A Bibliography of Mesopotamian Archaeological Sites*. Wiesbaden: Harrosowitz.
- 1995 "The Trouble With 'Hairies'." *Iraq* 57:159-166.

Emery, Walter Bryan

1961 *Archaic Egypt*. London: Penguin Books.

Engelbach, R.

1923 *Harageh*. British School of Archaeology in Egypt and Egyptian Research Account 28. London: British School of Archaeology in Egypt.

Englund, Robert K.

1983 "Dilmun in the Archaic Uruk Corpus," in (ed.) Daniel T. Potts, *Dilmun: New studies in the archaeology and early history of Bahrain*. Berliner Beiträge zum Vordern Orient 2. Berlin: Dietrich Reimer.

1988 "Administrative Timekeeping in Ancient Mesopotamia." *Journal of the Economic and Social History of the Orient* 31:121-185.

1993 "Review of *Before Writing* by Denise Schmandt-Besserat." *Science* 260:1670-1671.

1998 "Texts From the Late Uruk Period," in (eds.) Josef Bauer, Robert K. Englund, and Manfred Krebernik, *Mesopotamien: Späturuk-Zeit und frühdynastische Zeit*, *Orbis Biblicus et Orientalis* 160/1:15-236. Freiburg: Universitätsverlag.

Englund, Robert K., and Hans Jörg Nissen

1993 *Die lexicalischen Listen der archaischen Texte aus Uruk*. Ausgrabungen der Deutschen Forschungsgemeinschaft in Uruk-Warka 13. Archaische Texte aus Uruk 3. Berlin: Gebr. Mann.

Ess, Margarete van, and Pedde Friedhel

1992 *Uruk - Kleinfunde II: Metall und Asphalt, Farbreste, Fritte/ Faience, Glas, Holz, Knochen/ Elfbein, Leder, Muschel/ Perlmutter/ Schnecke, Schilf, Textilien*. Ausgrabungen in Uruk-Warka: Endberichte 7. Deutsches Archäologisches Institut, Abteilung Bagdad. (ed.) R. M. Boehmer. Mainz am Rhein: Philipp von Zabern.

Fairservis, Walter A.

1971-1972a "Preliminary Report on the First Two Seasons at Hierakonpolis: Part I." *Journal of the American Research Center in Egypt* 9:7-27.

1971-1972b "Preliminary Report on the First Two Seasons at Hierakonpolis. Part V: Summation and conclusions." *Journal of the American Research Center in Egypt* 9:67-68.

1983 *Hierakonpolis: The graffiti and the origins of Egyptian writing*. Occasional Papers in Archaeology. The Hierakonpolis Project 2. Poughkeepsie: Vassar College.

1991 "A Revised View of the Narmer Palette." *Journal of the American Research Center in Egypt* 28:1-20.

Falkenstein, Adam

1936 *Archaische Texte aus Uruk*. Ausgrabungen der Deutschen Forschungsgemeinschaft in Uruk-Warka 2. Leipzig: O. Harrassowitz.

1957-1971 "Girsu A. Nach den Texten," in (ed.) Dietz Otto Edzard, *Reallexikon der Assyriologie (Dritter Band)*:385-391. Berlin und New York: Walter de Gruyter.

1966a *Die Inschriften Gudeas von Lagaš: I Einleitung*. *Analecta Orientalia* 30. Rome: Pontificum Institutum Biblicum.

1966b "Sumerische Bauausdrücke." *Orientalia, Nova Series* 35:229-246.

1967 "The Prehistory of Western Asia," in (eds.) Jean Bottéro, Elena Cassin, and Jean Vercoutter, *The Near East: The early civilizations*:1-51. London: Weidenfeld and Nicholson.

1974 *The Sumerian Temple City*. Monographs on the Ancient Near East 1 (1). Malibu: Undena.

Falkner, M.

1957-1971 "Geierstele (archäologisch)," in (ed.) Dietz Otto Edzard, *Reallexikon der Assyriologie (Dritter Band)*:194. Berlin und New York: Walter de Gruyter.

Falkowitz, Robert S.

1984 "Notes on "Lugalbanda and Enmerkar"," in (ed.) Jack M. Sasson, *Studies in Literature from the Ancient Near East by Members of the American Oriental Society Dedicated to Samuel Noah Kramer*:103-115. American Oriental Series 65: American Oriental Society.

Faltings, Dina, Pascale Ballet, Frank Förster, *et. al.*

2000 "Zweiter Vorbericht über die Arbeiten in Buto von 1996 bis 1999." *Mitteilungen des Deutschen Archäologischen Instituts, Abteilung Kairo* 56:131-179.

Faltings, Dina, and E. Christiana Köhler

1996 "Vorbericht über die Ausgrabungen des DAI in Tell el-Fara 'in/Buto 1993 bis 1995.'" *Mitteilungen des Deutschen Archäologischen Instituts, Abteilung Kairo* 52:87-114.

Farber-Flügge, Gertrud

1973 *Der Mythos 'Inanna und Enki' unter besonder Berücksichtigung der List der Me*. Studia Pohl 10. Rome: Pontificum Institutum Biblicum.

Fauconnier, Gilles

1994 *Mental Spaces: Aspects of meaning construction in natural language*. Cambridge: Cambridge University Press.

1997 *Mappings in Thought and Language*. Cambridge: Cambridge University Press.

2001 "Conceptual Blending and Analogy," in (eds.) Dedre Gentner, Keith James Holyoak, and Boicho N. Kokinov, *The Analogical Mind: Perspectives from cognitive science*:255-285. A Bradford Book. Cambridge: MIT Press.

Fauconnier, Gilles, and Eve Sweetser, (eds.)

1996 *Spaces, Worlds, and Grammar*, Cognitive theory of language and culture. Chicago: University of Chicago Press.

Fauconnier, Gilles, and Mark Turner

1998 "Conceptual Integration Networks." *Cognitive Sciences* 22, 2:133-187.

2002 *The Way We Think: Conceptual blending and the mind's hidden complexities*. New York: Basic Books.

Ferioli, Piera, Enrica Fiandra, Gian Giacomo Fissore, *et. al.*, (eds.)

1994 *Archives Before Writing: Proceedings of the international colloquium, Oriolo Romano, October 23-25, 1991*, Pubblicazioni degli Archivi di Stato Pubblicazioni del Centro internazionale di ricerche archeologiche antropologiche e storiche 1. Turin: Scriptorium

Ferrara, A.J.

1973 *Nanna-Suen's Journey to Nippur*. Studia Pohl: Series Maior 2. Rome: Biblical Institute Press.

Finkbeiner, Uwe

1993 *Uruk - Analytisches Register zu den Grabungsberichten. Kampagnen 1912/13 bis 1976/77*. Deutsches Archäologisches Institut, Abteilung Baghdad. Berlin: Gebr. Mann Verlag.

Finkbeiner, Uwe, and Wolfgang Röllig, (eds.)

1986 *Gamdat Nasr: Period or regional style?* Beihefte zum Tübinger Atlas des Vorderen Orients, Reihe B (Geisteswissenschaften) Nr. 62. Wiesbaden: Dr. Ludwig Reichert.

Finkel, I. L., and M. J. Geller, (eds.)

1997 *Sumerian Gods and Their Representations*, Cuneiform Monographs 7. Groningen: Styx.

Firth, Cecil Mallaby

1927 *The Archaeological Survey of Nubia. Report for 1910-1911*. Ministry of Finance, Egypt: Survey of Egypt. Cairo: Government Press.

Fischer, Henry

1958 "A Fragment of Late Predynastic Egyptian Relief from the Eastern Delta." *Artibus Asiae* 21:64-88.

1962a "The Cult and Nome of the Goddess Bat." *Journal of the American Research Center in Egypt* 1:7-18, 19-23.

1962b "Varia Aegyptiaca. 7. The Stelae of Den and Other Rulers of the Archaic Period." *Journal of the American Research Center in Egypt* 2:41-43.

1987 "The Ancient Egyptian Attitude Towards the Monstrous," in (eds.) A. E. Farkas, P. O. Harper, and E. Harrison, *Monsters and Demons in the Ancient and Medieval Worlds: Papers presented in honor of Edith Porada*:13-26. Mainz am Rhein: Philipp von Zabern.

1989 "The Origin of Egyptian Hieroglyphs," in (ed.) Wayne M. Senner, *The Origins of Writing*:59-76. Lincoln, Nebraska: University of Nebraska Press.

Fodor, Jerry A.

1975 *The Language of Thought*. The Language and Thought Series. Cambridge, Massachusetts: Harvard University Press.

1983 *The Modularity of Mind*. Cambridge, Massachusetts: MIT Press.

1990a *A Theory of Content and Other Essays*. Cambridge, Massachusetts: MIT Press.

1990b "Fodor's Guide to Mental Representation," *A Theory of Content and Other Essays*:3-30. Cambridge, Massachusetts: MIT Press.

1990c "Précis of Modularity of Mind," *A Theory of Content and Other Essays*:195-206. Cambridge, Massachusetts: MIT Press.

1995 *The Elm and the Expert: Mentalese and Its Semantics*. The 1993 Jean Nicod Lectures. Cambridge, Massachusetts: MIT Press.

1998a *In Critical Condition: Polemical Essays on Cognitive Science and the Philosophy of Mind*. A Bradford Book. Cambridge, Massachusetts: MIT Press.

- 1998b *Concepts: Where Cognitive Science Went Wrong*. Oxford Cognitive Science. Oxford: Oxford University Press.
- Forest, Jean-Daniel  
1999 *Les premiers temples de Mésopotamie (4e et 3e millénaires)*. BAR International Series 765. Oxford: Archaeopress.
- Fossey, Charles  
1904 *Manuel d'Assyriologie: fouilles, écriture, langues, littérature, géographie, histoire, religion, institutions, art. Tome premier: Explorations et fouilles, déchiffrement des cuneiforms, origine et histoire de l'écriture*. Paris: Ernest Leroux.
- Foster, Benjamin R.  
1981 "A New Look at the Sumerian Temple State." *Journal of the Economic and Social History of the Orient* 24, 3:225-241.  
1985 "The Sargonic Victory Stele From Telloh." *Iraq* 47:15-30.  
1989 "A Sargonic Archive From the Lagash Region," in (eds.) Hermann Behrens, Darlene Loding, and Martha T. Roth, *DUMU-E2-DUB-BA-A: Studies in honor of Åke Sjöberg*:155-166. Occasional Publications of the Samuel Noah Kramer Fund 11. Philadelphia: The University Museum.
- Foster, Benjamin R.  
1996 *Before the Muses: An anthology of Akkadian literature. Volume I: Archaic, classical, mature*. 2nd revised ed. Bethesda, Maryland: CDL Press.
- Fouadi, Abdul-Hadi al-  
1969 *Enki's Journey to Nippur: The journeys of the gods*. Ph.D. dissertation, University of Pennsylvania.  
1976 "Bassetki Statue With an Old Akkadian Inscription of Naram-Sin of Agade (B.C. 2291-2255)." *Sumer* 32, I/II:63-76.
- Frandsen, Paul J.  
1997 "On Categorization and Metaphorical Structuring: Some remarks on Egyptian art and language." *Cambridge Archaeological Journal* 7, 1:71-104.
- Frankfort, Henri  
1924 *Studies in the Early Pottery of the Near East: Vol. I. Mesopotamia, Syria, and Egypt and their earliest interrelations*. Occasional Papers 6. London: Royal Anthropological Institute of Great Britain and Ireland.  
1932 *Archaeology and the Sumerian Problem*. Studies in Ancient Oriental Civilization 4. Chicago: University of Chicago Press.  
1933 *Tell Asmar, Khafaje, and Khorsabad: Second Preliminary Report of the Iraq Expedition*. Oriental Institute Communications 16. Chicago: University of Chicago Press.  
1934 *Iraq Excavations of the Oriental Institute, 1932 - 1933: Third Preliminary Report of the Iraq Expedition*. Oriental Institute Communications 17. Chicago: University of Chicago Press.  
1935 "Early Dynastic Sculptured Maceheads," in (ed.) Anonymous, *Miscellanea orientalia: Dedicata Antonio Deimel, annos LXX complenti*:105-121. *Analecta orientalia; commentationes scientificae de rebus Orientis antiqui* 12. Roma: Pontificio Istituto Biblico.

- 1936 *Progress of the Work of the Oriental Institute in Iraq, 1934 - 1935: Fifth preliminary report of the Iraq Expedition.* Oriental Institute Communications 20. Chicago: University of Chicago Press.
- 1939a *Cylinder Seals: A Documentary essay on the art and religion of the ancient Near East.* London: Macmillan and Co.
- 1939b *Sculpture of the Third Millennium B. C. from Tell Asmar and Khafajah.* Oriental Institute Publications 44. Chicago: University of Chicago Press.
- 1941 "The Origins of Monumental Architecture in Egypt." *The American Journal of Semitic Languages and Literature* 58, 4:325-358.
- 1943 *More Sculpture From the Diyala Region.* Oriental Institute Publications 60. Chicago: University of Chicago Press.
- 1948 *Kingship and the Gods: A study of ancient Near Eastern religion as the integration of society and nature.* Chicago: University of Chicago Press.
- 1949 "Review of *Tello* by Andre Parrot." *Journal of Near Eastern Studies* 8, 1:58-60.
- 1955 *Stratified Cylinder Seals from the Diyala Region.* Oriental Institute Publications 72. Chicago: University of Chicago Press.
- 1969 *The Art and Architecture of the Ancient Orient (4th rev. ed.).* The Pelican History of Art. Baltimore: Pelican Books.

Frankfort, Henri, Thorkild Jacobsen, and Conrad Preusser

- 1932 *Tell Asmar and Khafaje: The first season's work at Eshnunna, 1931 - 1932.* Oriental Institute Communications 13. Chicago: University of Chicago.

Frankfort, Henri, Seton Lloyd, and Thorkild Jacobsen

- 1940 *The Gimilsin Temple and the Palace of the Rulers at Tell Asmar.* Oriental Institute Publications 43. Chicago: University of Chicago.

Frankfort, Henri, J. A. Wilson, T. Jacobsen, et. al.

- 1946 *The Intellectual Adventure of Ancient Man: An essay on speculative thought in the ancient Near East.* Chicago: University of Chicago.

Frayne, Douglas R.

- 1992 *The Early Dynastic List of Geographical Names.* American Oriental Series 74. New Haven: American Oriental Society.

French, Howard W.

- 1997 "The Rich Intellectual Legacy of Bamoun Palace." *International Herald Tribune*, 22 October:2.

Friberg, Jöran

- 1984 "Numbers and Measures in the Earliest Written Records." *Scientific American* 250:78-85.
- 1994 "Pre-literate Counting and Accounting in the Middle East: A constructively critical review of Schmandt-Besserat's *Before Writing*." *Orientalistische Literaturzeitung* 89, 5/6:477-502.

Friedman, Renée F.

- 1996 "The Ceremonial Centre at Hierakonpolis Locality HK29A," in (ed.) Jefferey Spencer, *Aspects of Early Egypt*:16-35. London: British Museum Press.

- Friedman, Renée F., and Barbara Adams  
 1992 *The Followers of Horus: Studies dedicated to Michael Allen Hoffman 1944-1990*. Egyptian Studies Association Publication 2. Oxbow Monograph 20. Oxford: Oxbow Books.
- Frifelt, Karen  
 1975 "On Prehistoric Settlement and Chronology of the Oman Peninsula." *East and West* 25:359-424.
- Furlong, Iris  
 1987 *Divine Headdresses of Mesopotamia in the Early Dynastic Period*. British Archaeological Reports: International Series 334. Oxford: British Archaeological Reports.
- Gadd, C. J.  
 1930 "Entemena: A new incident." *Revue d'assyriologie et d'archéologie orientale* 27, 3:125-126.  
 1990 [1971] "The Cities of Babylonia," in (eds.) I. E. S. Edwards, C. J. Gadd, and N. G. L. Hammond, *The Cambridge Ancient History (Vol. 1, Part 2)*:93-144. Cambridge: Cambridge University Press.
- Gadd, C. J., and Leon Legrain  
 1928 *Ur Excavations, Texts (Vol. 1). Royal Inscriptions*. Publications of the Joint Expedition of the British Museum and of the Museum of the University of Pennsylvania to Mesopotamia. London: Harrison and Sons Limited.
- Garbini, Giovanni  
 1962 *Le origini della statuaria sumerica (The Origins of Sumerian statuary)*. Università (Roma). Centro di studi semitici. Serie archeologica, 3. Roma: Università degli studi Centro di studi semitici.
- Gardin, Jean-Claude, and Christopher S. Peebles, (eds.)  
 1992 *Representations in Archaeology*. Bloomington: Indiana University Press.
- Gardiner, Allen  
 1982 *Egyptian Grammar (3rd ed.)*. Oxford: Griffith Institute/Ashmolean Museum.
- Gardner, Howard  
 1983 *Frames of Mind: The theory of multiple intelligences*. New York: Basic Books.  
 1993 *Multiple Intelligences: The theory in practice*. New York: Basic Books.
- Garstang, John  
 1906 "Excavations at Hierakonpolis, at Esna and in Nubia." *Annales du Service des Antiquités de l'Égypte* 7.
- Gattis, Merideth, (ed.)  
 2001 *Spatial Schemas and Abstract Thought*. Cambridge, Massachusetts: MIT Press.
- Gautier, Patrick, and Béatrix Midant-Reynes  
 1995 "La tête de mausse du Roi Scorpion." *Archéo-Nil* 5.

Gazzaniga, Michael S., (ed.)

1997 *Conversations in the Cognitive Neurosciences*, A Bradford Book. Cambridge, Massachusetts: MIT Press.

2000 *The New Cognitive Neurosciences*, A Bradford book. Cambridge, Massachusetts: MIT.

Gelb, Ignace J.

1963 *A Study of Writing: A Discussion of the general principles governing the use and evolution of writing* (2nd rev. ed.). Chicago: University of Chicago Press.

1986 "Ebla and Lagash: Environmental contrast," in (ed.) Harvey Weiss, *The Origins of Cities in Dry-Farming Syria and Mesopotamia in the Third Millennium B.C.*:157-167. Guilford, Connecticut: Four Quarters.

Gelb, Ignace J., et. al., (eds.)

1956-present *The Assyrian Dictionary*. Chicago: Oriental Institute of the University of Chicago.

Gelb, Ignace J., and Burkhard Kienast

1990 *Die Altakkadischen Königsinschriften des Dritten Jahrtausends v. Chr.* Freiburger Altorientalische Studien 7. Wiesbaden: Franz Steiner Verlag GmbH.

Gelb, Ignace J., Piotr Steinkeller, and Robert M. Whiting

1991 *Earliest Land Tenure Systems in the Near East: Kudurrus* (2 Vols.). Oriental Institute Publications 104. Chicago: University of Chicago Press.

Geldhill, J., B. Bender, and M. T. Larsen, (eds.)

1988 *State and Society: The Emergence and development of social hierarchy and political centralization*, One World Archaeology 4. London: Routledge & Kegan Paul.

Geller, S.

1916 *Die sumerisch-assyrische Serie Lugal-e ud me-lam-bi nir-gál*. Breslau; Leiden: E. J. Brill.

Gelman, Susan A.

1999 "Domain Specificity," in (eds.) Robert A. Wilson and Frank C. Keil, *The MIT Encyclopedia of the Cognitive Sciences*:238-239. A Bradford Book. Cambridge, Massachusetts: MIT Press.

Genouillac, Henri de

1910 "Ancienne stèle de victoire." *Revue d'assyriologie et d'archéologie orientale* 7, 4:151-156.

1924-1925 *Fouilles français d'El' Akhymer. Premières recherches archéologiques à Kish* (2 Vols.). Paris: Geuthner.

1930 "La campagne du printemps de 1929 à Tello." *Journal asiatique*.

Genouillac, Henri de

1930 "Rapport sur les travaux de la Mission de Tello. Iie Campagne: 1929-1930." *Revue d'assyriologie et d'archéologie orientale* 27, 2:169-186.

1934 *Fouilles de Tello (Tome I): Époques présargoniques*. Mission Archéologique du Musée du Louvre et du Ministère de l'Instruction Publique. Paris: Geuthner.

- 1936 *Fouilles de Tello (Tome II): Époques de Ur IIIe Dynastie et de Larsa*. Mission Archéologique du Musée du Louvre et du Ministère de l'Instruction Publique. Paris: Geuthner.
- Gentner, Dedre, Keith James Holyoak, and Boicho N. Kokinov, (eds.)  
2001 *The Analogical Mind: Perspectives from cognitive science*, A Bradford Book. Cambridge: MIT Press.
- Ghirshman, Roman  
1938 *Fouilles de Sialk, près de Kashan, 1933, 1934, 1937 (Volume I)*. Musée du Louvre, Département des Antiquités Orientales, Serie Archéologique 4. Paris: Librairie Orientaliste Paul Geuthner.
- Gibson, McGuire  
1972-1975 "Hursagkalama B. Archäologisch," in (ed.) D. O. Edzard, *Reallexikon der Assyriologie (Vierter Band)*:520-521. Berlin: Walter de Gruyter.  
1976 "Kiš. B. Archäologisch," in (ed.) D. O. Edzard, *Reallexikon der Assyriologie (Fünfter Band)*:613-620. Berlin: Walter de Gruyter.  
1981 *Uch Tepe I: Tell Razuk, Tell Ahmed al-Mughir, Tell Ajamat*. State Organization of Antiquities and Heritage, Baghdad, Hamrin Report 10. The Chicago-Copenhagen Expedition to the Hamrin. Copenhagen. Chicago: Akademisk Forlag. Oriental Institute.  
1982 "A Re-Evaluation of the Akkad Period in the Diyala Region on the Basis of Recent Excavations at Nippur and in the Hamrin." *American Journal of Archaeology* 86:531-538.
- Gibson, McGuire, and Robert D. Biggs  
1991 *The Organization of Power: Aspects of bureaucracy in the ancient Near East (2nd ed.)*. Studies in Ancient Oriental Civilizations 46. Chicago: University of Chicago Press.
- Gibson, McGuire, and Augusta McMahon  
1995 "Investigation of the Early Dynastic-Akkadian Transition: Report of the 18th and 19th seasons of excavation in Area WF, Nippur." *Iraq* 57:1-42.  
1997 "The Early Dynastic-Akkadian Transition, Part 2. The Authors' Response." *Iraq* 59:9-15.
- Glassner, Jean-Jacques  
1992 "Inanna et les me," in (ed.) Maria de Jong Ellis, *Nippur at the Centennial: Papers Read at the 35e Rencontre Assyriologique Internationale, Philadelphia, 1988*:55-86. Occasional Publications of the Samuel Noah Kramer Fund 14. Philadelphia: University Museum.  
1993 "Le roi prêtre en mésopotamie, au milieu du 3e millénaire -- mythe ou réalité?," *Ancient Near East and India: Intercultural Religious Parallels. The Franco-Finnish Symposium: 10-11th Nov. 1990, The Finnish Institute, Paris*:9-19. *Studia Orientalia* 70. Helsinki: Finish Oriental Society.  
2000 *Écrire à Sumer: l'invention du cunéiforme*. L'univers historique. Paris: Seuil.
- Glockel, Wolfgang  
1982 *Die Stratigraphie und Chronologie der Ausgrabungen des Diyala Gebietes und der Stadt Ur in der Zeit von Uruk/Eanna VI bis zur Dynastie von Akkad*. Rome: G. Bretschneider.

Goetze, Albrecht

1961 "Early Kings of Kish." *Journal of Cuneiform Studies* 15:105-111.

Goff, Beatrice Laura

1963 *Symbols of Prehistoric Mesopotamia*. New Haven and London: Yale University Press.

Goldman, Alvin I, (ed.)

1995 *Readings in Philosophy and Cognitive Science*. Cambridge, Massachusetts: MIT Press.

Goodman, Nelson

1983 [1954] *Fact, Fiction, and Forecast (4th ed.)*. Cambridge, Massachusetts: Harvard University Press.

1988 *Languages of Art: An approach to a theory of symbols*. Indianapolis: Hackett Publishing Co.

Goody, Jack

1987 *The Interface Between the Written and the Oral*. Studies in Literacy, Family, Culture, and the State. Cambridge: Cambridge University Press.

1994 *The Domestication of the Savage Mind*. Cambridge: Cambridge University Press.

Gophna, Ram

1992 "The Contacts Between 'En Besor Oasis, Southern Canaan, and Egypt During the Late Predynastic and the Threshold of the First Dynasty; A further assessment," in (ed.) Edwin C. M. van den Brink, *The Nile Delta in Transition: 4th - 3rd Millennium B.C.. Proceedings of a Seminar Held in Cairo, 21. - 24 October 1990, at the Netherlands Institute of Archaeology and Arabic Studies*:385-394. Tel Aviv: Distributed by the Israel Exploration Society for Edwin C. M. van den Brink.

Gould, Stephen J.

1977 *Ontogeny and Phylogeny*. Cambridge, Massachusetts: Harvard University Press.

1991 "Exaptation: A crucial tool for an evolutionary psychology." *Journal of Social Issues* 47, 3:43-65.

2002 *The Structure of Evolutionary Theory*. Cambridge, Massachusetts: The Belknap Press of Harvard University Press.

Gould, Stephen J., and C. Lewontin

1979 "The Spandrels of San Marco and the Panglossian Paradigm." *Proceedings of the Royal Society B*. 105:581-598.

Gould, Stephen J., and S. Vrba

1982 "Exaptation: A missing term in the science of form." *Paleobiology* 8:4-45.

Grayson, Albert Kirk

1993 "Königslisten und Chroniken: B. Akkadisch," in (ed.) D. O. Edzard, *Reallexikon der Assyriologie (Sechster Band)*:86-135. Berlin: Walter de Gruyter.

- Graziani, Simonetta, (ed.)  
 2000 *Studi sul Vicino Oriente antico dedicati alla memoria di Luigi Cagni*, Istituto universitario orientale; Dipartimento di studi asiatici, Series minor 61. Napoli: Istituto universitario orientale.
- Green, Anthony  
 1997 "Myths in Mesopotamian Art," in (eds.) I. L. Finkel and M. J. Geller, *Sumerian Gods and Their Representations*:135-158. Cuneiform Monographs 7. Groningen: Styx.
- Green, Edward J., and William T. Greenough  
 1986 "Altered Synaptic Transmission in Denate Gyrus of Rats Reared in Complex Environments: Evidence from hippocampal slices maintained in vitro." *Journal of Neuropsychology* 55, 4:739-750.
- Green, F. W.  
 1951 *The Prehistoric Wall-painting in Egypt: Reproduction of the wall painting in the prehistoric cemetery of Hierakonpolis*. London: British School of Egyptian Archaeology.
- Green, M. W.  
 1981 "The Construction and Implementation of the Cuneiform Writing System." *Visible Language* 15:345-372.  
 1989 "Early Cuneiform," in (ed.) Wayne M. Senner, *The Origins of Writing*:43-58. Lincoln, Nebraska: University of Nebraska Press.
- Green, M. W. , and Hans Jörg Nissen  
 1987 *Zeichenliste der archaischen Texte aus Uruk*. Ausgrabungen der Deutschen Forschungsgemeinschaft in Uruk-Warka 11. Archaische Texte aus Uruk 2. Berlin: Gebr. Mann.
- Greenberg, Joseph H.  
 1963 *Essays in Linguistics*. Chicago: University of Chicago Press.  
 1966 *Universals of Language*. Cambridge, Massachusetts: MIT Press.  
 1969 "Language Universals: A research frontier." *Science* 166:473-478.  
 1975 "Research on Language Universals." *Annual Review of Anthropology* 4:75-93.
- Greenough, William T., James E. Black, and Christopher S. Wallace  
 1987 "Experience and Brain Development." *Child Development* 58:539-559.
- Greenough, William T., John W. McDonald, Robert M. Parnisari, et. al.  
 1986 "Environmental Conditions Modulate Degeneration and New Dendrite Growth in Cerebellum of Senescent Rats." *Brain Research* 380:136-143.
- Grégoire, Jean Pierre  
 1962 *La province méridionale de l'état de Lagash*. Luxembourg: Bourg-Bourger.
- Gregory, Richard L.  
 1987 "Piaget, Jean (1896-1980)," in (ed.) Richard L. Gregory, *The Oxford Companion to the Mind*:621-622. Oxford: Oxford University Press.  
 1987 *The Oxford Companion to the Mind*. Oxford: Oxford University Press.

- 1997 (5th ed.) *Eye and Brain: The Psychology of Seeing*. Princeton Science Library. Princeton: Princeton University Press.
- Gregory, Richard L., John Harris, Priscilla Heard, *et. al.*, (eds.)  
1995 *The Artful Eye*. Oxford: Oxford University Press.
- Groenewegen-Frankfort, H. A.  
1951 *Arrest and Movement: An essay on space and time in the representation of art of the ancient Near East*. London: Farber and Farber.  
  
1970 “‘Narratives’ in Ancient Egypt.” *Art News Annual* 36:112-121.
- Gumperz, John J., and Stephen C. Levinson, (eds.)  
1996 *Rethinking Linguistic Relativity*, Studies in the Social and Cultural Foundations of Language 17. Cambridge: Cambridge University Press.
- Gunter, Ann C., (ed.)  
1990 *Investigating Artistic Environments in the Ancient Near East*. Washington.
- Gustavus, Arnold  
1931-1941 “Das gi-ku(g) der Dioritt-Platte Ur-Ninas.” *Archiv für Orientforschung* 8:53-54.
- Güterbock, Hans, Jacobsen, and Thorkild  
1965 *Studies in Honor of Benno Landsberger on his Seventy-Fifth Birthday*. Assyriological Studies 16. Chicago: Oriental Institute.
- Güterbock, Hans G.  
1957 “Narration in Anatolian, Syrian, and Assyrian Art.” *American Journal of Archaeology* 61:62-71, Pls. 21-26.
- Hahn, Joachim  
1972 “Aurignacian Signs, Pendants and Art Object in Central and Eastern Europe.” *World Archaeology* 3, 2.: 252-256
- Haines, R. C.  
1961 “The Temple of Inanna at Nippur. The Ancient Holy City of Sumer: Further excavations at this notable site.” *The Illustrated London News*, 9 September:408-411.
- Hall, Emma Swan  
1986 *The Pharaoh Smites his Enemies*. Müncher Ägyptologische Studien 46. Munich: Deutscher Kunstverlag.
- Hall, H. R., and Sir C. Leonard Woolley  
1927 *Al-'Ubaid*. Publications of the Joint Expedition of the British Museum and the Museum of the University of Pennsylvania to Mesopotamia. Ur Excavations 1. Oxford: Oxford University Press.

Halle, David

1999 "Material Artefacts, Symbolism, Sociologists and Archaeologists," in (eds.) Colin Renfrew and Chris Scarre, *Cognition and Material Culture: The archaeology of symbolic storage*:51-60. McDonald Institute Monographs. Cambridge: McDonald Institute for Archaeological Research.

Hallo, William W.

1957 *Early Mesopotamian Royal Titles: A philologic and historical analysis*. American Oriental Series 43. New Haven: American Oriental Society.

1973 "The Date of the Fara Period: A case study in the historiography of early Mesopotamia." *Orientalia, Nova Series* 42:228-238.

Hansen, Donald P.

1963 "New Votive Plaques from Nippur." *Journal of Near Eastern Studies* 22, 3:145-168.

1965 "The Relative Chronology of Mesopotamia. Part II. The Pottery Sequence at Nippur from the Middle Uruk to the End of the Old Babylonian Period (3400-1600 B.C.)," in (ed.) Robert W. Ehrich, *Chronologies in Old World Archaeology*:201-202. Chicago: University of Chicago Press.

1970 "Al-Hiba, 1968-1969: A preliminary report." *Artibus Asiae* 32.

1971 "Some Early Dynastic I Sealings From Nippur," in (eds.) David Gordon Mitten, John Griffiths Pedley, and Scott Jane Ayer, *Studies Presented to George M. A. Hanfmann*:49-54. Fog Art Museum; Harvard University Monographs in Art and Archaeology 2. Mainz am Rhein: Philipp von Zabern

1973 "Al-Hiba 1970-1971: A preliminary report." *Artibus Asiae* 35, 1/2.

1975a "Frühsumerische und fröhdyastische Flachbildkunst," in (ed.) Winfried Orthmann, *Der alte Orient*:179-192. Propyläen Kunstgeschichte 14. Berlin: Propyläen Verlag.

1975b "Frühsumerische und fröhdyastische Rundplastik," in (ed.) Winfried Orthmann, *Der alte Orient*:158-170. Propyläen Kunstgeschichte 14. Berlin: Propyläen Verlag.

1978 "Al-Hiba: A summary of four seasons of excavations (1968-1976)." *Sumer* 34, 1/2:: 80: 80-81: 80-.

1980-1983 "Lagas. B. Archäologisch," in (ed.) Dietz Otto Edzard, *Reallexikon der Assyriologie und vorderasiatischen Archäologie (Sechster Band)*:422-430. Berlin und New York: Walter de Gruyter.

1987 "The Fantastic World of Sumerian Art: Seal impressions from ancient Lagash," in (eds.) A. E. Farkas, P. O. Harper, and E. Harrison, *Monsters and Demons in the Ancient and Medieval Worlds: Papers presented in honor of Edith Porada*:53-63. Mainz am Rhein: Philipp von Zabern.

1990 "The Sixth Season at al-Hiba." *Mar Sipri* 3, 1:1-3.

1992 "Royal Building Activity at Sumerian Lagash in the Early Dynastic Period." *Biblical Archaeologist* 55, 4:206 - 211.

Hansen, Donald P., and George F. Dales

1962 "The Temple of Inanna Queen of Heaven at Nippur." *Archaeology* 15, 2:75-84.

Hardin, C. L., and Luisa Maffi, (eds.)

1997 *Color Categories in Thought and Language*. Cambridge: Cambridge University Press.

- Harnad, Stevan, (ed.)  
1987 *Categorical Perception: The groundwork of cognition*. Cambridge: Cambridge University Press.
- Harner, Michael J.  
1984 (1972) *The Jivaro: People of the sacred waterfalls*. Berkeley: University of California Press.
- Harris, Paul L.  
1999 "Mimesis, Imagination and Role-play," in (eds.) Colin Renfrew and Chris Scarre, *Cognition and Material Culture: The archaeology of symbolic storage*:61-66. McDonald Institute Monographs. Cambridge: McDonald Institute for Archaeological Research.
- Harris, Rivkah  
1957-1971 "Gipar," in (ed.) D. O. Edzard, *Reallexikon der Assyriologie (Dritter Band)*:377-399. Berlin: Walter de Gruyter.  
1965 "The Journey of the Divine Weapon," *Studies in Honor of Benno Landsberger on his Seventy-fifth Birthday*. Assyriological Studies 16. Chicago: University of Chicago Press.
- Harris, Roy  
1986 *The Origin of Writing*. La Salle: Open Court.
- Harris, Randy Allen  
1993 *The Linguistics Wars*. Oxford: Oxford University Press.
- Harris, William V.  
1989 *Ancient Literacy*. Cambridge, Massachusetts: Harvard University Press.
- Hartung, Ulrich  
1994 "Bemerkungen zur Chronologie der Beziehungen Ägyptens zu Südkanaan in spätprädynastischer Zeit." *Mitteilungen des Deutschen Archäologischen Instituts, Abteilung Kairo* 50:107-113.
- Hassan, Fekri  
1985 "Radiocarbon Chronology of Neolithic and Predynastic Sites in Upper Egypt and the Delta." *African Archaeological Review* 3:95-116.
- Hassan, Fekri, and Steven Robinson  
1987 "High-Precision Radiocarbon Chronometry of Ancient Egypt and Comparison with Nubia, Palestine and Mesopotamia." *Antiquity* 61:119-135.
- Hatt, Robert T.  
1959 *The Mammals of Iraq*. Miscellaneous Publications: Museum of Zoology, University of Michigan 106. Ann Arbor: University of Michigan.
- Hauser, Marc D.  
1996 *The Evolution of Communication*. A Bradford Book. Cambridge, Massachusetts: MIT Press.

Haussig, Hans Wilhelm

1965 *Götter und Mythen in Vordern Orient*. Die alten Kulturvölker 1. Stuttgart: Ernst Klett Verlag.

Havelock, Eric Alfred

1986 *The Muse Learns to Write: Reflections on Orality and Literacy from Antiquity to the Present*. New Haven: Yale University Press.

Hawkins, David

1979 "The Origin and Dissemination of Writing in Western Asia," in (ed.) P. R. S. Moorey, *The Origins of Civilization: Wolfson College lectures 1978*:128-166. Oxford: Oxford University Press.

Hawkins, John A., and Murray Gell-Mann, (eds.)

1992 *The Evolution of Human Languages: Proceedings of the Workshop on the Evolution of Human Languages, Held August 1989 in Santa Fe, New Mexico*, Santa Fe Institute; Studies in the Sciences of Complexity. Proceedings 11. Redwood City: Addison-Wesley.

Hayes, William Christopher

1990 (5th rev. ed.) *The Scepter of Egypt: A background for the study of the Egyptian antiquities in the Metropolitan Museum of Art. Part 1: From the earliest times to the end of the Middle Kingdom*. New York: Metropolitan Museum of Art.

Healey, John F.

1990 "The Early Alphabet," in (ed.) J. T. Hooker, *Reading the Past: Ancient writing from cuneiform to the alphabet*:197-258. Berkeley: University of California Press.

Hebb, Donald O.

1949 *The Organization of Behavior*. New York: John Wiley & Sons.

Hedeman, Anne D.

1991 *The Royal Image: Illustrations of the Grandes Chroniques de France 1274-1422*. Berkeley: University of California Press.

Heider, Eleanor (Eleanor Rosch)

1971 "'Focal' Color Areas and the Development of Color Names." *Developmental Psychology* 4:447-455.

1972 "Universals in Color Naming and Memory." *Journal of Experimental Psychology* 93:10-20.

Heider, Eleanor (Eleanor Rosch), and D. Oliver

1972 "The Structure of Color Space in Naming and Memory for Two Languages." *Cognitive Psychology* 3:337-354.

Heimpel, Wolfgang

1968 *Tierbilder in der sumerischen Literatur*. Studia Pohl: Dissertationes Scientifcae de Rebus Orientis Antiqui 2. Rome: Pontificum Institutum Biblicum.

1996 "The Gates of Eninnu." *Journal of Cuneiform Studies* 48:17-29.

2002 "The Lady of Girsu," in (ed.) Tzvi Abusch, *Riches Hidden in Secret Places: Ancient Near Eastern studies in memory of Thorkild Jacobsen*:155-160. Winona Lake: Eisenbrauns.

Heine, Brad

1997 *Cognitive Foundations of Grammar*. New York: Oxford University Press.

Heinrich, Ernst

1931 *Fara. Ergebnisse der Ausgrabungen der Deutschen Orient-Gesellschaft in Fara und Abu Hatab 1902-1903*. Staatliche Museen zu Berlin Vorderasiatische Abteilung. Berlin: H. S. Hermann.

1934 "Arbeiten in Eanna, im Stadtgebiet und im Südbau," in (eds.) Arnold Nöldeke, Ernst Heinrich, and E. Schott, Fünfter vorläufiger Bericht über die von der Notgemeinschaft der Deutschen Wissenschaften in Uruk unternommenen Ausgrabungen:5-38. *Abhandlungen der Preussischen Akademie der Wissenschaften. Philosophisch-historische Klasse. Jahrg. 1933, 5*. Berlin: Akademie der Wissenschaften in Kommission bei W. de Gruyter.

1936a "Review of *Fouilles de Telloh (Tome I)*." *Archiv für Orientforschung* 11:155-159.

1936b *Kleinfunde aus der archaischen Tempelschichten in Uruk*. Ausgrabungen der Deutschen Forschungsgemeinschaft in Uruk-Warka 1. Leipzig: Harrosowitz.

1940 "Review of *Fouilles de Telloh (Tome II)*." *Archiv für Orientforschung* 13:152-153.

1975 "Sumerisch-Akkadische Architektur," in (ed.) Winfried Orthmann, *Der alte Orient*:131-158. *Propyläen Kunstgeschichte* 18. Berlin: Propyläen Verlag.

1984 *Die Paläste im alten Mesopotamien*. Deutsches Archäologisches Institut, *Denkmäler Antiker Architektur* 15. Berlin: Walter de Gruyter.

Hennesy, John B.

1967 *The Foreign Relations of Palestine During the Early Bronze Age*. London: Quartich.

Henrickson, Elizabeth F., and Ingolf Thuesen

1989 *Upon this Foundation-The 'Ubaid Reconsidered: Proceedings from the 'Ubaid symposium Elsinore May 30th-June 1st 1988*. Carsten Niebuhr Institute Publications 10. Copenhagen: Museum Tusulanum Press.

Henrickx, Stan

1996 "The Relative Chronology of the Naqada Culture: Problems and possibilities," in (ed.) Jefferey Spencer, *Aspects of Early Egypt*:36-69. London: British Museum Press.

Herrmann, Georgina

1966 *The Source, Distribution, History and Use of Lapis Lazuli in Western Asia from the Earliest Times to the End of the Seleucid Era*. D. Phil. dissertation, University of Oxford. Faculty of Oriental Studies.

1968a "Lapis Lazuli in Early Phases of its Trade." *Iraq* 30:58-61.

1968b "Lapis Lazuli: The early phases of its trade." *Iraq* 30:21-57.

Herskovits, Melville J.

1932 "Population Statistics in the Kingdom of Dahomey." *Human Biology* 4.

1940 *The Economic Life of Primitive Peoples*. New York: Knopf.

## Heuzey, Léon

- 1888 “Un palais Chaldéen d’après les découvertes de M. de Sarzec.”
- 1893a “Nouveaux Monuments du roi Our-Nina découvertes par M. de Sarzec.” *Revue d’assyriologie et d’archéologie orientale* 3, 1:13-19.
- 1893b “La stèle du roi Éannadou (stèle des vautours) d’après les nouveaux fragments découvertes par M. de Sarzec.” *Revue d’assyriologie et d’archéologie orientale* 3, 1:1-12.
- 1894a “Deux armes sacrées Chaldéennes.” *Revue d’assyriologie et d’archéologie orientale* 3, 2:53-58.
- 1894b “Une villa royale Chaldéen: Environ 4000 ans avant notre ère.” *Revue d’assyriologie et d’archéologie orientale* 3, 2:59-64.
- 1894c “Mission de M. de Sarzec en Chaldée: Huitième campagne de fouilles.” *Revue d’assyriologie et d’archéologie orientale* 3, 3:65-68.
- 1895a “Le nom d’Agade.” *Revue d’assyriologie et d’archéologie orientale* 3, 4:113-117.
- 1895b “Les galets sacrés du roi Éannadou.” *Revue d’assyriologie et d’archéologie orientale* 3, 4:105-112.
- 1897a “La construction du roi Our-Nina d’après les levés et les notes de M. de Sarzec.” *Revue d’assyriologie et d’archéologie orientale* 4, 4:8-122.
- 1897b “Sceaux inédits es rois de Agadé.” *Revue d’assyriologie et d’archéologie orientale* 4, 1:1-12.
- 1897c “Texts Chaldéens très antiques (améliorations et nouvelles lectures).” *Revue d’assyriologie et d’archéologie orientale* 4:34-36.
- 1898 “La construction du roi Our-Nina: Notes complémentaires d’après les découvertes de M. de Sarzec.” *Revue d’assyriologie et d’archéologie orientale* 5, 1:26-32.
- 1902 *Catalogue des antiquités Chaldéennes: Sculpture et gravure à la pointe*. Paris: Libraires-Imprimeries Réunies.
- 1904a “De la décoration des vases Chaldéens.” *Revue d’assyriologie et d’archéologie orientale* 6, 2:129-139.
- 1904b “Autres monuments figurés provenant des fouilles du Capitane Cros.” *Revue d’assyriologie et d’archéologie orientale* 6, 2:53-58.

## Heuzey, Léon, and François Thureau-Dangin

- 1909 *Restitution matérielle de la Stèle des vautours*. Paris: Ernest Ledoux.

## Heuzey, Léon Alexandre, and Gustave Charles Ernest Choquin de Sarzec

- 1900 *Une villa royale chaldéenne vers l’an 4000 avant notre ère, d’après les levés et les notes de m. de Sarzec*. Paris: E. Leroux.

## Hirschfeld, Lawrence A., and Susan A. Gelman

- 1994a “Towards a Topography of the Mind: An introduction to domain specificity,” in (eds.) Lawrence A. Hirschfeld and Susan A. Gelman, *Mapping the Mind: Domain specificity in cognition and culture*:3-35. Cambridge: Cambridge University Press.
- 1994b *Mapping the Mind: Domain specificity in cognition and culture*. Cambridge: Cambridge University Press.

## Hodge, Robert, and Gunter Kress

- 1993 *Language as Ideology*. London: Routledge & Kegan Paul.

- Hoenigswald, Henry M., and Linda F. Wiener, (eds.)  
 1987 *Biological Metaphor and Cladistic Classification : An Interdisciplinary Perspective*. Philadelphia: University of Pennsylvania Press.
- Hoffman, Michael Allen  
 1971-1972 "Preliminary Report on the First Two Seasons at Hierakonpolis, Part IV: Test excavations at Locality 14." *Journal of the American Research Center in Egypt* 9:49-66.
- Hoffman, Michael Allen  
 1976 "City of the Hawk: Seat of ancient Egypt's ancient civilization." *Expedition* 18:32-41.  
 1979 *Egypt Before the Pharaohs*. Austin: University of Texas Press.  
 1980 "New Excavations at Hierakonpolis: A multidisciplinary approach to the origins of the Egyptian state." *Anthropology* 4:51-70.  
 1982a *The Predynastic of Hierakonpolis: An interim report*. Egyptian Studies Association Publication 1. Giza: Cairo University Hebarium.  
 1982b "A Preliminary Report on the 1982 Season at Hierakonpolis." *Newsletter of the American Research Center in Egypt* 119:14-21.  
 1982c "A Preliminary Report on the First Two Seasons at Hierakonpolis: Part IV. Test Excavations at Locality 14." *Journal of the American Research Center in Egypt* 9:49-66.  
 1986 *An Interim Report to the National Endowment for the Humanities on Predynastic Research at Hierakonpolis (N.E.H. Grant No. RO-20805-85)*. Columbia: University of South Carolina.  
 1987 *A Final Report to the National Endowment for the Humanities on Predynastic Research at Hierakonpolis, 1985-1986 (N.E.H. Grant No. RO-20805-85)*. Columbia: University of South Carolina.
- Hoffmeier, James Karl, and Edmund S. Meltzer, (eds.)  
 1983 *Egyptological Miscellanies: A tribute to Professor Ronald J. Williams*, Ancient World 6. Chicago: Ares.
- Hofstadter, Douglas R., and Fluid Analogies Research Group  
 1995 *Fluid Concepts and Creative Analogies: Computer models of the fundamental mechanisms of thought*. New York: Basic Books.
- Hoijer, Harry  
 1954 *Language in Culture: Conference on the interrelations of language and other aspects of culture*. Chicago: University of Chicago Press.  
 1954 "The Sapir-Whorf Hypothesis," in (ed.) Harry Hoijer, *Language in Culture: Conference on the interrelations of language and other aspects of culture*:92-105. Chicago: University of Chicago Press.
- Holmes, Diane L.  
 1992a "Chipped Stone-Working Craftsmen, Hierakonpolis and the Rise of Civilization in Egypt," in (eds.) Renée F. Friedman and Barbara Adams, *The Followers of Horus: Studies dedicated to Michael Allen Hoffman 1944-1990*:35-44. Egyptian Studies Association Publication 2. Oxbow Monograph 20. Oxford: Oxbow Books.

- 1992b "The Evidence and Nature of Contacts Between Upper and Lower Egypt During the Predynastic: A view from Upper Egypt," in (ed.) Edwin C. M. van den Brink, *The Nile Delta in Transition: 4th - 3rd Millennium B.C.. Proceedings of a Seminar Held in Cairo, 21. - 24 October 1990, at the Netherlands Institute of Archaeology and Arabic Studies*:301-316. Tel Aviv: Distributed by the Israel Exploration Society for Edwin C. M. van den Brink.
- Holmès-Frederiq, D.  
1970 *Les cachets mésopotamiens protohistoriques*. Documenta et Monumenta Orientis Antiqui Volumen Quattuordecium. Leiden: E. J. Brill.
- Holquist, Michael, and Caryl Emerson  
1994 *The Dialogic Imagination: Four essays by M. M. Bakhtin*. Austin: University of Texas Press.
- Holyoak, Keith James, Dedre Gentner, and Boicho N. Kokinov  
2001 "Introduction: The Place of Analogy in Cognition," in (eds.) Dedre Gentner, Keith James Holyoak, and Boicho N. Kokinov, *The Analogical Mind: Perspectives from cognitive science*. A Bradford Book. Cambridge: MIT Press.
- Hooker, J. T., (ed.)  
1990 *Reading the Past: Ancient writing from cuneiform to the alphabet*. Berkeley: University of California Press.
- Horowitz, Wayne  
1998 *Mesopotamian Cosmic Geography*. Mesopotamian Civilizations 8. Winona Lake: Eisenbrauns.
- Houlihan, Patrick F.  
1986 *The Birds of Ancient Egypt*. Warminster, England: Aris and Phillips.
- Hrouda, Barthel  
1971 *Vorderasien I: Mesopotamien, Babylonien, Iran und Anatolien*. Munich: C. H. Beck.  
1991a *Der alte Orient: Geschichte und Kultur des alten Vorderasien*. Munich: C. Bertelsmann.  
1991b "Kunst. Mesopotamien," in (ed.) Barthel Hrouda, *Der alte Orient: Geschichte und Kultur des alten Vorderasien*:271-298. Munich: C. Bertelsmann.
- Hruska, Blahoslav  
1975 *Der Mythenadler Anzu in Literatur und Vorstellungen des alten Mesopotamien*. Assyriologia 2, Az eötvös lorand tudományegyetem okori történeti tanszékainek kiadványai 13. Budapest: Eötvös lorand tudományegyetem okori történeti tanszékainek.
- Huck, Geoffrey, and John A. Goldsmith  
1995 *Ideology and Linguistic Theory: Noam Chomsky and the deep structure debates*. London: Routledge & Kegan Paul.

Hughes, Claire, and Robert Plomin

2000 "Individual Differences in Early Understanding of Mind: Genes, non-shared environment and modularity," in (eds.) Peter Carruthers and Andrew Chamberlain, *Evolution and the Human Mind: Modularity, language and meta-cognition*:47-61. Cambridge: Cambridge University Press.

Humboldt, Wilhelm von

1971 [1836] "Linguistic Variability & Intellectual Development." Miami: University of Miami Press.

Humphrey, Nicholas K.

1988 "The Social Function of Intellect," in (eds.) Richard W. Byrne and Andrew Whiten, *Machiavellian Intelligence: Social expertise and the evolution of intellect in monkeys, apes, and humans*:2-26. Oxford: Clarendon Press.

Hunn, Eugene S.

1975 "A Measure of the Degree of Correspondence of Folk to Scientific Biological Classification." *American Ethnologist* 2, 2:309-327.

Hussey, Mary Inda

1931 "A Statuette of the Founder of the First Dynasty of Lagash." *Revue d'assyriologie et d'archéologie orientale* 28, 2:45-57.

Intelligence Division, Naval

1944 *Iraq and the Persian Gulf*. Naval Intelligence Division: Geographical Handbook Series B. R. 524 (Restricted). London: Naval Intelligence Division.

Jackendoff, Ray

1992 *Languages of the Mind: Essays on mental representation*. Cambridge, Massachusetts: MIT Press.

1997 *The Architecture of the Language Faculty*. Linguistic Inquiry, Monograph 28. Cambridge, Massachusetts: MIT Press.

Jacobsen, Thorkild

1939 *The Sumerian King List*. Assyriological Studies 11. Chicago: Oriental Institute.

1943 "Parerga Sumerologica." *Journal of Near Eastern Studies* 2:112-121.

1957 "Early Political Development in Mesopotamia." *Zeitschrift für Assyriologie und Vorderasiatische Archäologie*:91-140.

1960 "The Waters of Ur." *Iraq* 22:174-185.

1969a "A Survey of the Girsu (Telloh) Region." *Sumer* 25.

1969b "Some Sumerian City Names." *Journal of Cuneiform Studies (Special Volume Honoring Professor Albrecht Goetze)* 21:100-103.

1970 *Toward the Image of Tammuz and Other Essays on Mesopotamian History and Culture*. (ed.) William L. Moran. Harvard Semitic Series 21. Cambridge, Massachusetts: Harvard University Press.

1970 [1961] "Formative Tendencies in Sumerian Religion," in (ed.) William L. Moran, *Toward the Image of Tammuz and Other Essays on Mesopotamian History and Culture*:1-15. Harvard Semitic Series 21. Cambridge, Massachusetts: Harvard University Press.

- 1970 [1963] "Mesopotamian Gods and Pantheons," in (ed.) William L. Moran, *Toward the Image of Tammuz and Other Essays on Mesopotamian History and Culture*:16-38. Harvard Semitic Series 21. Cambridge, Massachusetts: Harvard University Press.
- 1970 [1939] "The Assumed Conflict Between the Sumerians and Semites in Early Mesopotamian History," in (ed.) William L. Moran, *Toward the Image of Tammuz and Other Essays on Mesopotamian History and Culture*:187-192. Harvard Semitic Series 21. Cambridge, Massachusetts: Harvard University Press.
- 1970 [1943] "Primitive Democracy in Ancient Mesopotamia," in (ed.) William L. Moran, *Toward the Image of Tammuz and Other Essays on Mesopotamian History and Culture*:157-172. Harvard Semitic Series 21. Cambridge, Massachusetts: Harvard University Press.
- 1970 [1963] "Ancient Mesopotamian Religion: The Central concerns," in (ed.) William L. Moran, *Toward the Image of Tammuz and Other Essays on Mesopotamian History and Culture*:39-47. Harvard Semitic Series 21. Cambridge, Massachusetts: Harvard University Press.
- 1975 "Religious Drama in Ancient Mesopotamia," in (eds.) Hans Goedicke and J. J. M. Roberts, *Unity and Diversity: Essays in the history, literature and religion of the ancient Near East*. Baltimore: Johns Hopkins University Press.
- 1976a *The Treasures of Darkness: A history of mesopotamian religion*. New Haven: Yale University.
- 1976b "The Stele of the Vultures Col. I-X," in (ed.) J. W. Heimerdinger Barry L. Eichler, and Å. Sjöberg, *Samuel Noah Kramer Anniversary Volume: Cuneiform studies in honor of Samuel Noah Kramer*:247-259. *Alter Orient und Altes Testament Veröffentlichungen zur Kultur und Geschichte des Alten Orients und des Alten Testaments* 25. Kevelaer; Neukirchner-Vluyn: Verlag Butzon & Bercker.
- 1987a *The Harps that Once... Sumerian Poetry in Translation*. New Haven: Yale University Press.
- 1987b "The Graven Image," in (eds.) Patrick D. Miller, Paul D. Hanson, and S. Dean McBride, *Ancient Isrealite Religion: Essays in honor of Frank Moore Cross*:15-32. Philadelphia: Fortress.
- 1989a "God or Worshipper," in (eds.) Albert Leonard Jr. and Bruce B. Williams, *Essays in Ancient Civilization Presented to Helene J. Kantor*:125-134. *Studies in Ancient Oriental Civilizations* 47. Chicago: University of Chicago Press.
- 1989b "Lugalbanda and Ninsuna." *Journal of Cuneiform Studies* 41/1:69-86.
- 1991 "The Term Ensi," in (eds.) Piotr Michalowski, Piotr Steinkeller, Elizabeth Caecilia Stone, et. al., *Velles paraules: Ancient Near Eastern studies in honor of Miguel Civil on the occasion of his sixty-fifth birthday*:113-122. *Aula orientalis: Revista de estudios del Próximo Oriente Antiguo* 9. Sabadell (Barcelona), Spain: Editorial AUSA.

Jakob-Rost, Liane, Evelyn Klengel-Brandt, Joachim Marzahn, et. al.

1992 *Die Vorderasiatischen Museum: Staatlich Museen zu Berlin*. Mainz am Rhein: Philipp von Zabern.

Jakobsen, Roman

1987 *Language in Literature*. (ed.) Krystyna Pomorska and Stephen Rudy. Cambridge, Massachusetts: The Belknap Press of Harvard University Press.

1990a *On Language*. (ed.) Linda R. Waugh and Monique Monville-Burston. Cambridge, Massachusetts: Harvard University Press.

- 1990b “Langue and Parole: Code and message,” in (eds.) Linda R. Waugh and Monique Monville-Burston, *On Language*:80-110. Cambridge, Massachusetts: Harvard University Press.
- 1990c “Some Questions of Meaning,” in (eds.) Linda R. Waugh and Monique Monville-Burston, *On Language*:315-323. Cambridge, Massachusetts: Harvard University Press.
- 1990d “The Speech Event and the Functions of Language,” in (eds.) Linda R. Waugh and Monique Monville-Burston, *On Language*:69-79. Cambridge, Massachusetts: Harvard University Press.

Jakobsen, Roman, and Morris Halle

- 1956 *Fundamentals of Language*. Janua Linguarum. The Hague: Mouton & Co.

Jaritz, Kurt

- 1968 “Tilmun-Makkan-Meluhḥa.” *Journal of Near Eastern Studies* 27, 3:209-213.

Jaynes, Julian

- 1976 *The Origin of Consciousness and the Breakdown of the Bicameral Mind*. Boston: Houghton Mifflin Company.

Johnson, David Martel, and Christina E. Erneling, (eds.)

- 1997 *The Future of the Cognitive Revolution*. New York: Oxford University Press.

Johnson, Mark

- 1987 *The Body in the Mind: The bodily basis of meaning, imagination, and reason*. Chicago: University of Chicago Press.
- 1993 *Moral Imagination: Implications of cognitive science for ethics*. Chicago: University of Chicago Press.

Jordan, Julius, (ed.)

- 1931 *Zweiter vorläufiger Bericht über die von der Notgemeinschaft der Deutschen Wissenschaft in Uruk unternommenen Ausgrabungen*, Abhandlungen der Preussischen Akademie der Wissenschaften. Philosophisch-historische Klasse. Jahrg. 1930, 4. Berlin: Verlag der Akademie der Wissenschaften in Kommission bei Walter de Gruyter u. Co.
- 1932 *Dritter vorläufiger Bericht über die von der Notgemeinschaft der Deutschen Wissenschaft in Uruk unternommenen Ausgrabungen*, Abhandlungen der Preussischen Akademie der Wissenschaften. Philosophisch-historische Klasse. Jahrg. 1932, 2. Berlin: Verlag der Akademie der Wissenschaften in Kommission bei Walter de Gruyter u. Co.

Kahl, Jochem

- 1994 *Das System der ägyptischen Hieroglyphenschrift in der 0.-3 Dynastie*. Göttinger Forschungen IV: Ägypten 29. Wiesbaden: Harrasowitz.

Kaiser, Werner

- 1956 “Stand und Probleme der ägyptischen Vorgeschichtsforschung.” *Zeitschrift für ägyptische Sprach und Altertumskunde* 81:87-109.
- 1957 “Zur inneren Chronologie der Naquadakultur.” *Archaeologia Geographica* 6:69-77.
- 1964 “Einige Bemerkungen zur ägyptischen Frühzeit: III. Die Reichseinigung.” *Zeitschrift für ägyptische Sprach und Altertumskunde* 91:86-125.

- 1985a "Zu Entwicklung und Vorformen der frühzeitlichen Gräber mit reich gegliederter Oberbaufassade," in (ed.) Paule Posener-Kriéger, *Mélanges Gamal Eddin Mokhtar (Volume 2)*:25-38. Bibliothèque d'étude. Institut français d'archéologie orientale du Caire 97. Cairo: Institut français d'archéologie orientale du Caire.
- 1985b "Zur Südausdehnung der vorgeschichtlichen Deltakulturen und zur frühen Entwicklung in Oberägypten." *Mitteilungen des Deutschen Archäologischen Instituts, Abteilung Kairo* 41:61-87.
- 1990 "Zur Entstehung des gesamtägyptischen Staates." *Mitteilungen des Deutschen Archäologischen Instituts, Abteilung Kairo* 46:287-299.

Kantor, Helene J.

- 1942 "The Early Relations of Egypt with Asia." *Journal of Near Eastern Studies* 1:174-213.
- 1944 "The Final Phase of Predynastic Culture: Gerzean or Semainian (?)." *Journal of Near Eastern Studies* 3, 2:110-136.
- 1952 "Further Evidence for Mesopotamian Relations With Egypt." *Journal of Near Eastern Studies* 11:239-250.
- 1957 "Narration in Egyptian Art." *American Journal of Archaeology* 61:44-54, Pls. 11-16.
- 1965 "The Relative Chronology of Egypt and Its Foreign Correlations Before the Late Bronze Age," in (ed.) Robert W. Ehrich, *Chronologies in Old World Archaeology*:1-46. Chicago: University of Chicago Press.
- 1974 "Ägypten," in (eds.) Machteld J. Mellink and J. Filip, *Frühe Stufen der Kunst*:227-271. Propyläen Kunstgeschichte 13. Berlin: Propyläen Verlag.
- 1984 "The Ancestry of the Divine Boat (Sirsir?) of Early Dynastic and Akkadian Glyptic." *Journal of Near Eastern Studies* 43:277-280.
- 1992 "The Relative Chronology of Egypt and Its Foreign Correlations Before the First Intermediate Period," in (ed.) Robert W. Ehrich, *Chronologies in Old World Archaeology: Volume I*:3-21. Chicago: University of Chicago Press.

Kaplony, P.

- 1972-1975 "Ka-Haus," in (eds.) W. Helck and E. Otto, *Lexikon der Ägyptologie*:397-401. Wiesbaden: Otto Harrossowitz.

Karg, Norbert

- 1984 *Untersuchungen zur ältern fröhdyastischen Glyptik Babylonien. Aspekte regionaler Entwicklungen in der ersten Hälfte des 3. Jahrtausends*. Deutsches Archäologisches Institute, Abteilung Baghdad: Baghdader Forschungen 8. Mainz am Rhein: Philipp von Zabern.
- 1993-1997 "Mesilim. B. Archäologisch (mit Stilstufe)," in (ed.) D. O. Edzard, *Reallexikon der Assyriologie (Achter Band)*:74-81. Berlin: Walter de Gruyter.

Karmiloff-Smith, Annette

- 1992 *Beyond Modularity: A developmental perspective on cognitive science*. Cambridge, Massachusetts: MIT Press.
- 1994 "Précis of Beyond Modularity: A developmental perspective on cognitive science." *Behavioral and Brain Sciences* 17:693-745.

Kay, Paul

- 1996 "From 'Thought and Language' to 'Thinking and Speaking'," in (eds.) John J. Gumperz and Stephen C. Levinson, *Intra-Speaker Relativity*:97-114. *Studies in the Social and Cultural Foundations of Language* 17. Cambridge: Cambridge University Press.
- 1999 "Color Categorization," in (eds.) Robert A. Wilson and Frank C. Keil, *The MIT Encyclopedia of the Cognitive Sciences*:143-145. A Bradford Book. Cambridge, Massachusetts: MIT Press.

Kay, Paul, Brent Berlin, Luisa Maffi, *et. al.*

- 1997 "Color Naming Across Languages," in (eds.) C. L. Hardin and Luisa Maffi, *Color Categories in Thought and Language*:21-58. Cambridge: Cambridge University Press.

Keightley, David N.

- 1989 "The Origins of Writing in China: Scripts and Cultural Contexts," in (ed.) Wayne M. Senner, *The Origins of Writing*:171-202. Lincoln, Nebraska: University of Nebraska Press.

Kelley, A. L.

- 1983 "A Review of the Evidence Concerning Early Egyptian Ivory Knife Handles," in (eds.) James Karl Hoffmeier and Edmund S. Meltzer, *A Tribute to Professor Ronald J. Williams*, *Ancient World* 6:95-102. *The Ancient World Egyptological Miscellanies* 6. Chicago: Ares.

Kemp, Barry J.

- 1966 "Abydos and the Royal Tombs of the First Dynasty." *Journal of Egyptian Archaeology* 52:13-22.
- 1967 "The Egyptian 1st Dynasty Royal Cemetery." *Antiquity* 41:22-32.
- 1968 "The Osiris Temple at Abydos." *Mitteilungen des Deutschen Archäologischen Instituts, Abteilung Kairo* 23:138-155.
- 1973 "Photographs of the Decorated Tomb at Hierakonpolis." *Journal of Egyptian Archaeology* 59:36-43.
- 1975 "Architektur der Frühzeit," in (ed.) Claude Vandersleyen, *Das alte Ägypten*:99-112. *Propyläen Kunstgeschichte* 17. Berlin: Propyläen Verlag.
- 1980 "Egyptian Radiocarbon Dating: A reply to James Mellaart." *Antiquity* 54:25-28.
- 1989 *Ancient Egypt: Anatomy of a civilization*. London: Routledge & Kegan Paul.
- 1995 "How Religious Were the Ancient Egyptians?" *Cambridge Archaeological Journal* 5, 1:25-54.

Kemp, Barry J., Andrew Boyce, and James Harrell

- 2000 "The Colossi from the Early Shrine at Coptos in Egypt." *Cambridge Archaeological Journal* 10, 2:211-242.

Kempermann, Gerd, and Fred H. Gage

- 1999 "New Nerve Cells for the Adult Brain." *Scientific American* 280, 5:48-53.

Kempinski, Aharon

1992 "Reflections on the Role of the Egyptians in the Shefelah of Palestine in the Light of the Recent Soundings at Tel Erani," in (ed.) Edwin C. M. van den Brink, *The Nile Delta in Transition: 4th - 3rd Millennium B.C.. Proceedings of a Seminar Held in Cairo, 21. - 24 October 1990, at the Netherlands Institute of Archaeology and Arabic Studies*:419-425. Tel Aviv: Distributed by the Israel Exploration Society for Edwin C. M. van den Brink.

Kessler, Edward J., Christa Hansen, and Roger Shepard, N.

1984 "Tonal Schemata in the Perception of Music in Bali and the West." *Musical Perception* 2, 2:131-165.

Kienast, Burkhard, and W. Sommerfeld

1994 *Glossar zu den altAkkadischen Königinschriften des Dritten Jahrtausends v. Chr.* Freiburger Altorientalische Studien 8. Wiesbaden: Franz Steiner Verlag GmbH.

Kim, K. H. S., N. R. Relkin, K. M. Lee, et. al.

1997 "Distinct Cortical Areas Associated With Native and Second Languages (Letter to Nature)." *Nature* 388, 171:171-175.

King, Leonard W.

1910 *A History of Sumer and Akkad: An account of the early races of Babylonia from prehistoric times to the foundation of the Babylonian monarchy.* A History of Babylonia and Assyria I. London: Chatto & Windus.

1919 *A History of Babylon: From the foundation of the monarchy to the Persian conquest.* A History of Babylonia and Assyria II. London: Chatto & Windus.

Kinnier Wilson, J. V.

1985 *The Legend of Etana.* Warminster, England: Aris & Phillips.

Kittay, Eva Feder

1987 *Metaphor: Its Cognitive Force and Linguistic Structure.* Oxford: Clarendon Press.

Klein, Raymond M.

1999 "Hebb, Donald O.," in (eds.) Robert A. Wilson and Frank C. Keil, *The MIT Encyclopedia of the Cognitive Sciences.* A Bradford Book. Cambridge, Massachusetts: MIT Press.

Knapp, A. Bernard

1992 "Mesopotamian Chronology," in (ed.) David Noel Freedman, *Anchor Bible Dictionary: Volume 4 (K-N)*:714-720. New York: Doubleday.

Knecht, Heidi, Anne Pike-Tay, and Randall White, (eds.)

1993 *Before Lascaux: The complex record of the early Upper Paleolithic.* Boca Raton: CRC Press.

Kohl, Philip L.

1975 *Seeds of Upheaval: The Production of chlorite at Tepe Yahya and an analysis of commodity production in southwest Asia in the mid-third millennium.* Ph.D. dissertation, Harvard University.

Koldewey, Robert

1887 "Die altbabylonischen Gräber in Surghul und El Hibba." *Zeitschrift für Assyriologie und Vorderasiatische Archäologie* 2:403-430.

Kolers, Paul A., and William E. Smythe

1979 "Images, Symbols, and Skills." *Canadian Journal of Psychology* 33, 3:158-184.

Kosslyn, Stephen Michael

1994 *Image and Brain: The resolution of the imagery debate*. A Bradford Book. Cambridge, Mass: MIT Press.

1995 "Mental Imagery," in (eds.) Stephen M. Kosslyn and Daniel N. Osherson, *Visual Cognition. An Invitation to Cognitive Science: Volume 2*:267-296. Cambridge, Massachusetts: MIT Press.

Kosslyn, Stephen M., and Daniel N. Osherson, (eds.)

1995 *Visual Cognition and Action. An Invitation to Cognitive Science: Volume 2*. Cambridge, Massachusetts: MIT Press.

Kramer, Samuel Noah

1938 *Gilgamesh and the Huluppu-Tree: A reconstructed text*. Assyriological Studies 10. Chicago: Oriental Institute.

1952 *Enmerkar and the Lord of Aratta: A Sumerian epic tale of Iran and Iraq*. Philadelphia: The University Museum.

1961 *Sumerian Mythology: A study of spiritual and literary achievement in the third millennium, B.C. (Revised Edition)*. New York: Harper and Brothers.

1969 *The Sacred Marriage Rite: Aspects of faith, myth, and ritual in ancient Sumer*. Bloomington: University of Indiana Press.

1970 "The Dumuzi-Inanna Sacred Marriage Rite: Origin, development, character," in (ed.) André Finet, *Actes de la XVIIe Rencontre Assyriologique Internationale: Université Libre de Bruxelles, 30 Juin - 4 juillet 1969*:135-141. Ham-sur-Heure: Comité belge de recherches en Mésopotamie.

1974 "Kingship in Sumer and Akkad: The ideal king," in (ed.) Paul Garelli, *Le palais et la royauté (archéologie et civilisation)*:163-177. XIX Rencontre Assyriologique Internationale (1971). Paris.

1980 "Sumerian Literature and the British Museum: The promise of the future." *Proceedings of the American Philosophical Society* 124, 4.

1984 "Ninurta's Pride and Punishment." *Aula Orientalis* 2:231-237.

Kramer, Samuel Noah, and John Maier

1989 *Myths of Enki, the Crafty God*. New York: Oxford University Press.

Krebernik, Manfred

1998 "Die Texte aus Fara and Tell Abu Salabih," in (eds.) Josef Bauer, Robert K. Englund, and Manfred Krebernik, *Mesopotamien: Späturuk-Zeit und Frühdynastische Zeit*, *Orbis Biblicus et Orientalis* 160/1:237-430. Freiburg: Universitätsverlag.

Krecher, Joachim

1978 "Das sumerische Phonem |g<sup>h</sup>|," in (eds.) B. Hručka and G. Komoróczy, *Festschrift Lubar Matouš*:53. Budapest: Az Eötvös Tudományegyetem Ókori Történeti tanszékeinek kladványai.

Kroeper, Karla

1988 "The Excavations of the Munich East-Delta Expedition in Minshat in Abu Omar," in (ed.) Edwin C. M. van den Brink, *The Archaeology of the Nile Delta, Egypt: Problems and priorities. Proceedings of the Seminar held in Cairo, 19 - 22 October 1986, on the Occasion of the Fifteenth Anniversary of the Netherlands Institute of Archaeology and Arabic Studies in Cairo*:11-48. Amsterdam: Netherlands Foundation for Archaeological Research in Egypt.

1992 "Tombs of the Elite in Minshat Abu Omar," in (ed.) Edwin C. M. van den Brink, *The Nile Delta in Transition: 4th - 3rd Millennium B.C.. Proceedings of a Seminar Held in Cairo, 21. - 24 October 1990, at the Netherlands Institute of Archaeology and Arabic Studies*:127-150. Tel Aviv: Distributed by the Israel Exploration Society for Edwin C. M. van den Brink.

1996 "Minshat Abu Omar - Burials with Palettes," in (ed.) Jefferey Spencer, *Aspects of Early Egypt*:1-15. London: British Museum Press.

Kroeper, Karla, and Lech Kryzaniak

1992 "Two Ivory Boxes from Early Dynastic Graves at Minshat Abu Omar," in (eds.) Renée F. Friedman and Barbara Adams, *The Followers of Horus: Studies dedicated to Michael Allen Hoffman 1944-1990*:207-214. Egyptian Studies Association Publication 2. Oxbow Monograph 20. Oxford: Oxbow Books.

Kryzaniak, Lech

1977 *Early Farming Cultures of the Lower Nile: The Predynastic period*. Travaux d'archéologie méditerranéenne de l'Académie Polonaise des Sciences 21. Warsaw: Editions Scientifiques de Pologne.

Kryzaniak, Lech, and Michal Kobusiewicz, (eds.)

1984 *Origin and Early Development of Food-Producing Cultures in North-Eastern-Africa*, Studies in African Archaeology 1. Poznan: Polish Academy of Sciences.

Kuhn, Thomas S.

1996 "Metaphor in Science," in (ed.) Andrew Ortony, *Metaphor and Thought*:533-542. Cambridge: Cambridge University Press.

1996 *The Structure of Scientific Revolutions*. Chicago: University of Chicago Press.

Labat, Rene, and Florence Malbran-Labat

1988 *Manuel d'épigraphie Akkadiene: Signes, syllabaire, idéogrammes (6th edition)*. Paris: Librairie Orientaliste Paul Geuthner.

LaCapra, Dominick

1985 *History and Criticism*. Ithaca: Cornell University Press.

Lake, Mark

1992 "Review of *Origins of the Modern Mind. Three Stages in the Evolution of Culture and Cognition* by Merlin Donald." *Cambridge Archaeological Journal* 2, 2:267-270.

1999 "Digging for Memes: The role of material objects in cultural evolution," in (eds.) Colin Renfrew and Chris Scarre, *Cognition and Material Culture: The archaeology of symbolic storage*:77-88. McDonald Institute Monographs. Cambridge: McDonald Institute for Archaeological Research.

Lakoff, George

1987 *Women, Fire and Dangerous Things: What categories reveal about the mind.* Chicago: University of Chicago Press.

1988 "Cognitive Semantics," in (eds.) Umberto Eco, Marco Santambrogio, and Patrizia Violi, *Meaning and Mental Representations*:119-144. Bloomington: University of Indiana Press.

1996 "The Contemporary Theory of Metaphor," in (ed.) Andrew Ortony, *Metaphor and Thought*:202-251. Cambridge: Cambridge University Press.

Lakoff, George, and Mark Johnson

1980 *Metaphors We Live By.* Chicago: University of Chicago Press.

1999 *Philosophy in the Flesh: The embodied mind and its challenge to western thought.* New York: Basic Books.

Lakoff, George, and Rafael E. Nuñez

2000 *Where Mathematics Comes From: How the embodied mind brings mathematics into being.* New York: Basic Books.

Lakoff, George, and Mark Turner

1989 *More than Cool Reason: A field guide to poetic metaphor.* Chicago: University of Chicago Press.

Lambert, Maurice

1965 "Brèves communicationes." *Revue d'assyriologie et d'archéologie orientale* 59:81-84.

1966 "Pourquoi l'écriture est née en Mésopotamie." *Archeologia* 12:24-31.

Lambert, W. G.

1957-1971 "Götterlisten," in (ed.) Dietz Otto Edzard, *Reallexikon der Assyriologie (Dritter Band)*:473-479. Berlin und New York: Walter de Gruyter.

1986 "Ninurta Mythology in the Babylonian Creation Epic," in (ed.) Karl and Walter Sommerfeld Hecker, *Keilschriftliche Literaturen. Ausgewählte Vorträge der XXXII. Rencontre Assyriologique Internationale Münster, 8- 12.7.1985*:55-60. Berliner Beiträge zum Vordern Orient 6. Berlin: Dietrich Reimer Verlag.

1980 "New Fragments of Babylonian Epics." *Archiv für Orientforschung* 27:71-82.

1992 "The Reading of Uru-KA-gi-na Again." *Aula Orientalis* 10, 2:256-258.

1997 "Sumerian Gods: Combining the evidence of texts and art," in (eds.) I. L. Finkel and M. J. Geller, *Sumerian Gods and Their Representations*:1-10. Cuneiform Monographs 7. Groningen: Styx.

Landsberger, Benno

1961 "Einige unerkannt gebliebene oder verkannte Nimina des Akkadischen." *Wiener Zeitschrift für die Kunde des Morgenlandes* 57:1-21.

1974 [1944] *Three Essays on the Sumerians.* Translated by Maria de Jong Ellis Monographs on the Ancient Near East 1 (2). Malibu: Undena.

Langacker, Ronald W.

1987 *Foundations of Cognitive Grammar (Vol. 1): Theoretical prerequisites.* Stanford: Stanford University Press.

1991 *Foundations of Cognitive Grammar (Vol. 2): Descriptive application*. Stanford: Stanford University Press.

Larsen, Mogens Trolle

1988a "Introduction: Literacy and social complexity," in (eds.) J. Geldhill, B. Bender, and M. T. Larsen, *State and Society: The Emergence and development of social hierarchy and political centralization:173-191*. One World Archaeology 4. London: Routledge & Kegan Paul.

1988b "The Rôle of Writing and Literacy in the Development of Social and Political Power," in (eds.) J. Geldhill, B. Bender, and M. T. Larsen, *State and Society: The Emergence and development of social hierarchy and political centralization:173-191*. One World Archaeology 4. London: Routledge & Kegan Paul.

Layard, Austen Henry

1849 *The Monuments of Nineveh: From drawings made on the spot*. London: J. Murray.

Lebeau, Marc, Alexander Pruß, Michael Roaf, *et. al.*

2000 "Stratified Archaeological Evidence and Compared Periodizations in the Syrian Jezirah during the Third Millenium B.C.," in (eds.) Catherine Marro and Harald Hauptman, *Chronologies des pays du Caucase et de l'Euphrate aux IVe-IIIe millenaires. From the Euphrates to the Caucasus: Chronologies for the IVth -IIIrd millennium B.C.. Vom Euphrat in den Kaukasus: vergleichende Chronologie des IV. und III. Jahrtausends v. Chr. Actes du colloque d'Istanbul, 16-19 décembre 1998*, Institut Français d'études Anatoliennes d'Istanbul; *Varia Anatolica* 11:167-192. Paris: de Boccard.

Legrain, Leon

1929a "The Boudoir of Queen Shubad." *The Museum Journal* 20, 3 and 4:211-245.

1929b "Gem Cutters in Ancient Ur." *The Museum Journal* 20, 3 and 4:258-306.

Legrain, Leon

1933 "Restauration de la stèle d'Ur-Nammu." *Revue d'assyriologie et d'archéologie orientale* 30, 3:111-115.

1936 *Archaic Seal-Impressions*. Publications of the Joint Expedition of the British Museum and the Museum of the University of Pennsylvania to Mesopotamia. Ur Excavations 3. Philadelphia and London: The Trustees of the Two Museums.

1951 *Seal Cylinders*. Publications of the Joint Expedition of the British Museum and the Museum of the University of Pennsylvania to Mesopotamia. Ur Excavations 10. Philadelphia and London: The Trustees of the Two Museums.

Lenzen, Heinrich J.

1941 *Die Entwicklung der Ziggurrat von ihren Anfängen bis zur Zeit der III. Dynastie von Ur*. Ausgrabungen der Deutschen Forschungsgemeinschaft in Uruk-Warka 4. Leipzig: Harrosowitz.

1949 "Die Tempel der Schicht Archaisch IV in Uruk." *Zeitschrift für Assyriologie* 15:1-20.

1955 "Mesopotamische Tempelanlagen von der Frühzeit bis zum zweiten Jahrtausend." *Zeitschrift für Assyriologie* 17:1-36.

- 1959 *XV. vorläufiger Bericht über die von dem Deutschen Archäologischen Institut und der Deutschen Orient-Gesellschaft aus Mitteln der Deutschen Forschungsgemeinschaft unternommenen Ausgrabungen in Uruk-Warka: Winter 1956/57*, Abhandlungen der Deutschen Orient-Gesellschaft 4. Berlin: Gebr. Mann.
- 1963 *XIX. vorläufiger Bericht über die von dem Deutschen Archäologischen Institut und der Deutschen Orient-Gesellschaft aus Mitteln der Deutschen Forschungsgemeinschaft unternommenen Ausgrabungen in Uruk-Warka: Winter 1960/61*, Deutsches Archäologisches Institut, Abteilung Baghdad. Berlin: Gebr. Mann.
- 1968 *XXIV. vorläufiger Bericht über die von dem Deutschen Archäologischen Institut und der Deutschen Orient-Gesellschaft aus Mitteln der Deutschen Forschungsgemeinschaft unternommenen Ausgrabungen in Uruk-Warka: Winter 1965/66*, Abhandlungen der Deutschen Orient-Gesellschaft 13. Berlin: Gebr. Mann.
- 1974 "Die architektur in Eanna in der Uruk IV Periode." *Iraq* 36:111-128.
- 1975 "Die Architectur der Schicht Uruk Arch. III (Djemdet Nasr) in Eanna." *Studia Orientalia* 46:169-192.

Leonard Jr., Albert, and Bruce B. Williams

- 1989 *Essays in Ancient Civilization Presented to Helene J. Kantor*. Studies in Ancient Oriental Civilizations 47. Chicago: University of Chicago Press.

Lepschy, Giulio, (ed.)

- 1994 *History of Linguistics (Volume I): The eastern traditions of linguistics*. Edited by Longman Linguistics Library. Longman. London.

Leslie, A. M.

- 1994 "ToMM, ToBY, and Agency: Core architecture and domain specificity," in (eds.) Lawrence A. Hirschfeld and Susan A. Gelman, *Mapping the Mind: Domain specificity in cognition and culture*:119-148. Cambridge: Cambridge University Press.

Lévi-Strauss, Claude

- 1964 *Totemism*. London: Merlin Press.
- 1966 *The Savage Mind (La pensée sauvage)*. London: Weidenfeld and Nicholson.

Levy, Thomas E. , Edwin C.M. van den Brink, Yuval Goren, *et. al.*

- 1995 "New Light on King Narmer and the Protodynastic Egyptian Presence in Canaan." *Biblical Archaeologist* 58, 1:26-35.

Lichacovf, Nicholas P.

- 1907 "Drevniejsija bully i piecati Sirpuly." *Mémoires de la Société Impériale russe, Saint-Pétersbourg* 4:Plates.

Lieberman, Stephen J.

- 1977 *The Sumerian loanwords in Old-Babylonian Akkadian*. Harvard Semitic Studies 22. Missoula: Published by Scholars Press for Harvard Semitic Museum.
- 1980 "Of Clay Pebbles, Hollow Clay Balls, and Writing: A Sumerian view." *American Journal of Archaeology* 84:339-358.

- Lion, Brigitte  
 1992 "La circulation des animaux exotiques au Proche-orient antique," in (eds.) Dominique Charpin and M. Francis Joannès, *La circulation des biens, des personnes et des idées dans le Proche-orient ancien: Actes de la XXXVIIIe Rencontre Internationale (Paris, 8-10 juillet 1991)*:357-365. Paris: Editions Recherche sur les Civilisations.
- Liverani, Mario,  
 1995 (rev. ed.) *El antiguo oriente: Historia, sociedad, economía*. Translated by Juan Vivanco. Barcelona: Crítica (Grijalbo Mondatori, S.A.).
- Lloyd, Seton  
 1961 *The Art of the Ancient Near East*. London: Thames and Hudson.
- Lounsbury, Floyd  
 1989 "The Ancient Writing of Mesoamerica," in (ed.) Wayne M. Senner, *The Origins of Writing*:203-238. Lincoln, Nebraska: University of Nebraska Press.
- Lowe, E. J.  
 1999 "Personal Experience and Belief: The significance of external symbolic storage for the emergence of modern human cognition," in (eds.) Colin Renfrew and Chris Scarre, *Cognition and Material Culture: The archaeology of symbolic storage*:89-96. McDonald Institute Monographs. Cambridge: McDonald Institute for Archaeological Research.
- Lucas, Alfred  
 1989 *Ancient Egyptian Materials and Techniques*. 4th ed., (ed.) J. R. revised and enlarged by Harris. London: Histories and Mysteries of Man Ltd.
- Lucy, John A.  
 1992 *Language Diversity and Thought: A reformulation of the linguistic relativity hypothesis*. Studies in the Social and Cultural Foundations of Language 12. Cambridge: Cambridge University Press.  
 1996 "The Scope of Linguistic Relativity: An analysis and review of empirical research," in (eds.) John J. Gumperz and Stephen C. Levinson, *Intra-Speaker Relativity*:203-224. Studies in the Social and Cultural Foundations of Language 17. Cambridge: Cambridge University Press.
- Luria, Alexander R.  
 1973 *The Working Brain: An introduction to neuropsychology*. New York: Basic Books.  
 1976 *Cognitive Development: Its cultural and social foundations*. Translated by Martin Lopez-Morillas and Lynn Solotaroff. Cambridge, Massachusetts: Harvard University Press.  
 1982 *Language and Cognition*. New York: John Wiley & Sons.  
 1988 *The Mind of a Mnemonist: A little book about a vast memory*. Cambridge, Massachusetts: Harvard University Press.
- Lynch, Aaron  
 1996 *Thought Contagion: How belief spreads through society*. New York: Basic Books.

- Lythoe, A. M., and D. Dunham  
 1965 *The Predynastic Cemetery N 7000: Naga-ed-Dêr Part IV*. University of California Publications: Egyptian Archaeology 7. Berkeley: University of California Press.
- MacCormac, Earl R.  
 1985 *A Cognitive Theory of Metaphor*. Cambridge, Massachusetts: MIT Press.
- MacKay, Ernest  
 1925 *Report on the Excavation of the "A" Cemetery at Kish, Mesopotamia (Part I)*. Field Museum of Natural History Anthropology, Memoirs 1,1. Chicago: Field Museum-Oxford University Joint Expedition.  
 1929 *A Sumerian Palace and the "A" Cemetery at Kish, Mesopotamia (Part II)*. Field Museum of Natural History Anthropology, Memoirs 1, 2. Chicago: Field Museum-Oxford University Joint Expedition.  
 1931 *Report on Excavations at Jemdet Nasr, Iraq*. Field Museum of Natural History Anthropology, Memoirs 1, 3. Chicago: Field Museum-Oxford University Joint Expedition.
- Majer, Joseph  
 1992 "The Egyptian Desert and Egyptian Prehistory," in (eds.) Renée F. Friedman and Barbara Adams, *The Followers of Horus: Studies dedicated to Michael Allen Hoffman 1944-1990*:227-234. Egyptian Studies Association Publication 2. Oxbow Monograph 20. Oxford: Oxbow Books.
- Mallowan, Sir Max E. L.  
 1990 [1971] "The Early Dynastic Period in Mesopotamia," in (eds.) I. E. S. Edwards, C. J. Gadd, and N. G. L. Hammond, *The Cambridge Ancient History (Vol. 1, Part 2)*:238-291. Cambridge: Cambridge University Press.
- Mann Paul De  
 1986 "Dialogue and Dialogism," *The Resistance to Theory*:106-114. Theory and History of Literature 33. Minneapolis: University of Minnesota Press.
- Marcus, Joyce  
 1976 "The Origins of Mesoamerican Writing." *Annual Review of Anthropology* 5:35-67.  
 1980 "Zapotec Writing." *Scientific American* 242, 2:46-60.  
 1992 *Mesoamerican Writing Systems: Propagand, myth, and history in four ancient civilizations*. Princeton: Princeton University Press.  
 1995 "Writing, Literacy, and Performance in the New and Old Worlds. Review of *Writing Without Words: Alternative literacies in Mesoamerica and the Andes* by Elizabeth Hill Boone and Walter D. Mignolo." *Cambridge Archaeological Journal*:325-331.
- Marfoe, Leon  
 1987 "Cedar Forest to Silver Mountain: Social change and the development of long-distance trade in early Near Eastern societies," in (eds.) Michael Rowlands, Mogens Trolle Larsen, and Kristian Kristiansen, *Centre and Periphery in the Ancient World*:25-35. New Directions in Archaeology. Cambridge: Cambridge University Press.

Mark, Samuel

1997 *From Egypt to Mesopotamia: A study of predynastic trade routes*. London: Chatham Publishing.

Markman, Ellen M.

1989 *Categorization and Naming in Children: Problems of induction*. Cambridge, Massachusetts: MIT Press.

Marro, Catherine, and Harald Hauptman, (eds.)

2000 *Chronologies des pays du Caucase et de l'Euphrate aux IVe-IIIe millenaires. From the Euphrates to the Caucasus: Chronologies for the IVth -IIIrd millennium B.C.. Vom Euphrat in den Kaukasus: vergleichende Chronologie des IV. und III. Jahrtausends v. Chr. Actes du colloque d'Istanbul, 16-19 décembre 1998*, Institut Français d'études Anatoliennes d'Istanbul; Varia Anatolica 11. Paris: de Boccard.

Marschark, Marc, Patricia Siple, Diane Lillo Martin, et. al.

1997 *Relations of Language and Thought: The view from sign language and deaf children*. Counterpoints: Cognition, Memory, & Language. New York: Oxford University Press.

Marshak, Alexander

1990 "Early Hominid Symbol and Evolution of the Human Capacity," in (ed.) Paul Mellars, *The Emergence of Modern Humans*:257-298. Edinburgh: Edinburgh University Press.

1991a "The Taï Plaque and Calendrical Notation in the Upper Paleolithic." *Cambridge Archaeological Journal* 1, 1:25-61.

1991b *The Roots of Civilization (revised and expanded)*. Mount Kisco, New York: Moyer Bell Ltd.

Martin, Harriet P.

1988 *Fara: A reconstruction of the ancient Mesopotamian city of Shuruppak*. Birmingham: Chris Martin and Associates.

Martin, Richard A.

1940 *Ancient Seals of the Near East (Field Museum-Oxford University Joint Expedition)*. Field Museum of Natural History Anthropology Leaflet 34. Chicago: Field Museum of Natural History.

Matsushima, Eiko

1993a "Divine Statues in Mesopotamia: Their fashioning and clothing and their interaction with society," in (ed.) Eiko Matsushima, *Official Cult and Popular Religion in the Ancient Near East. Papers of the First Colloquium on the Ancient Near East- The City and its Life Held at The Middle Eastern Culture Center in Japan (Mitaka, Tokyo) March 20-22, 1992*:31-39. Heidelberg: Universitätsverlag C. Winter.

1993b *Official Cult and Popular Religion in the Ancient Near East. Papers of the First Colloquium on the Ancient Near East- The City and its Life Held at The Middle Eastern Culture Center in Japan (Mitaka, Tokyo) March 20-22, 1992*. Heidelberg: Universitätsverlag C. Winter.

Matthews, Donald M.

1997a "The Early Dynastic-Akkadian Transition, Part 1. When Did the Akkadian Period Begin?" *Iraq* 59:1-8.

1997b *The Early Glyptic of Tell Brak: Cylinder seals of third millennium Syria*. Orbis Biblicus et Orientalis. Series Archeologica 15. Fribourg: University Press Fribourg.

Matthews, Roger J.

1993 *Cities, Seals and Writing: Archaic seal impressions From Jemdet Nasr and Ur*. Materialien zu den Frühen Schrifzeugnissen des Vorderen Orients 2. Berlin: Gebr. Mann Verlag.

1997 "Girsu and Lagash," in (ed.) Eric M. Meyers, *The Oxford Encyclopedia of Archaeology in the Near East (Vol. 2)*:407-409. New York: Oxford University Press.

Matthews, Roger J., J. Nicholas Postgate, and R. J. Luby

1987 "Excavations at Abu Salabikh, 1985-1986." *Iraq* 49:91-120.

Maxwell-Hyslop, K. R.

1971 *Western Asiatic Jewellery: C. 3000-612 B.C.* London: Methuen and Co.

1992 "The Goddess Nanše: An attempt to identify her representation." *Iraq* 54:79-82.

McCawley, James D.

1993 *Everything that Linguists Always Wanted to Know About Logic\* (\*but were ashamed to ask) (2nd ed.)*. Chicago: University of Chicago Press.

McCown, Donald E., and R. C. Haines

1967 *Nippur, Vol. I: Temple of Enlil, Scribal Quarter and soundings. Excavations of the Joint Expedition to Nippur of the University Museum of Philadelphia and the Oriental Institute of the University of Chicago*. Oriental Institute Publications 78. Chicago: University of Chicago Press.

McCown, Donald E., R. C. Haines, Robert D. Biggs, et. al.

1978 *Nippur, Vol. II: The North Temple and Sounding E. Excavations of the Joint Expedition to Nippur of the American Schools of Oriental Research and the Oriental Institute of the University of Chicago*. Oriental Institute Publications 97. Chicago: University of Chicago Press.

McCulloch, Warren S.

1965 *Embodiments of Mind*. Cambridge, Massachusetts,: MIT Press.

McGovern, Patrick E., Ulrich Hartung, Virginia R. Badler, et. al.

1997 "The Beginnings of Winemaking and Viniculture in the Ancient Near East and Egypt." *Expedition* 39, 1:3-21.

McMahon, Augusta

1993 *The Early Dynastic to Akkadian Period Transition in Southern Mesopotamia*. Ph.D. dissertation, University of Chicago Press.

Medin, Douglas L., and Scott Atran, (eds.)

1999 *Folkbiology*, A Bradford Book. Cambridge, Massachusetts: MIT Press.

Mellaart, James

- 1979a "Egyptian and Near Eastern Chronology: A dilemma." *Antiquity* 53:6-18.  
 1979b "Early Urban Communities in the Near East, c. 9000 - 3400 BC," in (ed.) P. R. S. Moorey, *The Origins of Civilization: Wolfson College lectures 1978*:22-33. Oxford: Oxford University Press.

Mellars, Paul, (ed.)

- 1990 *The Emergence of Modern Humans*. Edinburgh: Edinburgh University Press.

Mellars, Paul, and Kathleen Rita Gibson

- 1996 *Modelling the Early Human Mind*. McDonald Institute Monographs. Cambridge: McDonald Institute for Archaeological Research.

Mellars, Paul, and Chris Stringer, (eds.)

- 1989 *The Human Revolution: Behavioral and biological perspectives on the origins of modern humans*. Edinburgh: Edinburgh University Press.

Mellart, James

- 1982 "Archaeological Evidence for Trade and Trade Routes between Syria and Mesopotamia and Anatolia During the Early and the Beginning of the Middle Bronze Age." *Studi Eblaiti* 5:15-32.

Mellink, Machteld J., and J. Filip

- 1974 *Frühe Stufen der Kunst*. Propyläen Kunstgeschichte 13. Berlin: Propyläen Verlag.

Merrell, Floyd

- 1992 "Semiotics: Semiotics and literature," in (ed.) William Bright, *International Encyclopedia of Linguistics*:408-412. New York: Oxford University Press.

Mervis, Carolyn B., Jack Catlin, and Eleanor Rosch

- 1975 "Development of the Structure of Color Categories." *Developmental Psychology* 11, 1:54-60.

Meyers, Eric M., (ed.)

- 1997 *The Oxford Encyclopedia of Archaeology in the Near East (5 Vols.)*. New York: Oxford University Press.

Michalowski, Piotr

- 1976 *The Royal Correspondence of Ur*. Ph.D. dissertation, Yale University.  
 1980 "Königsbriefe," in (ed.) Dietz Otto Edzard, *Reallexikon der Assyriologie (Sechster Band)*:31-38. Berlin und New York: Walter de Gruyter.  
 1984 "History as Charter: Some observations on the Sumerian King List," in (ed.) Jack M. Sasson, *Studies in Literature from the Ancient Near East by Members of the American Oriental Society Dedicated to Samuel Noah Kramer*:237-249. American Oriental Series 65: American Oriental Society.  
 1993 "Tokenism. Review of Before Writing by Denise Schmandt-Besserat." *American Anthropologist* 95:996-999.  
 1994 "Writing and Literacy in Early States: A Mesopotamianist perspective," in (ed.) Deborah Keller-Cohen:49-70. Cresskill, New Jersey: Hampton Press.

- Millet, N. B.  
 1990 "The Narmer Macehead and Related Objects." *Journal of the American Research Center in Egypt* 27:53-59.
- Milne, A. A.  
 1961 *Winnie-The-Pooh*. New York: E. P. Dutton & Co.
- Minsky, Marvin  
 1975 "A Framework for representing knowledge," in (eds.) Patrick Henry Winston and Berthold Horn, *The Psychology of Computer Vision*:211-277. McGraw-Hill Computer Science Series. New York: McGraw-Hill.  
 1985 *The Society of Mind*. New York: Simon & Schuster.
- Miroschedji, Pierre de  
 1973 "Vases et objets en steatite susiens du Louvre." *Cahiers de la Délégation Archéologique Française en Iran* 3.
- Mitchell, W. J. T., (ed.)  
 1981 *On Narrative*. Chicago: University of Chicago Press.  
 1986 *Iconology: Image, text, ideology*. Chicago: University of Chicago Press.
- Mithen, Steven S.  
 1994 "From Domain Specific to Generalized Intelligence: A Cognitive interpretation of the Middle/Upper Paleolithic transition," in (eds.) Colin Renfrew and Ezra B. Zubrow, *The Ancient Mind: Elements of cognitive archaeology*:29-40. New Directions in Archaeology. Cambridge: Cambridge University Press.  
 1996 *The Prehistory of the Mind: A search for the origins of art, religion and science*. London: Thames and Hudson.  
 1999 "The Supernatural Beings of Prehistory and the External Storage Of Religious Ideas," in (eds.) Colin Renfrew and Chris Scarre, *Cognition and Material Culture: The archaeology of symbolic storage*:97-106. McDonald Institute Monographs. Cambridge: McDonald Institute for Archaeological Research.  
 2000 "Mind, Brain and Material Culture: An archaeological perspective," in (eds.) Peter Carruthers and Andrew Chamberlain, *Evolution and the Human Mind: Modularity. language and meta-cognition*:207-217. Cambridge: Cambridge University Press.
- Mond, Robert, and Oliver H. Myers  
 1937 *The Cemeteries of Armant I* (2 Vols.). London: Egypt Exploration Society.
- Moorey, P. R. S.  
 1978 "Ancient Near-Eastern Cylinder Seals Acquired by the Ashmolean Museum, Oxford." *Iraq* 40:41-60.  
 1979 *Kish Excavations 1923-1933 (With a Microfiche Catalogue of the Objects in Oxford Excavated by the Oxford-Field Museum, Chicago, Expedition to Kish in Iraq, 1923-1933)*. Oxford: Clarendon Press.  
 1987 "On Tracking Cultural Transfers in Prehistory: The case of Egypt and Lower Mesopotamia in the fourth millennium BC," in (eds.) Mogens Trolle Larsen and Kristian Kristiansen, *Centre and Periphery in the Ancient World*:36-46. New Directions in Archaeology. Cambridge.  
 1990 "From Gulf to Delta in the Fourth Millennium BCE: The Syrian connection." *Eretz-Isreal* 21:63-82.

- 1994 *Ancient Mesopotamian Materials and Industries: The archaeological evidence*. Oxford: Clarendon Press.
- 1995 *From Gulf to Delta and Beyond*. Beer-Sheva 8 (1995). Jerusalem: Ben-Gurion University of the Negev Press.
- Moorey, P. R. S., (ed.)  
1979 *The Origins of Civilization: Wolfson College lectures 1978*. Oxford: Oxford University Press.
- Moortgat, Anton  
1949 *Tammuz: Der Unsterblichkeitsglaube in der altorientalischen Bildkunst*. Berlin: Walter de Gruyter.  
1969 *The Art of Ancient Mesopotamia*. London: Phaidon.  
1988 *Vorderasiatische Rollsiegel: Eine Beitrag zur Geschichte der Steinschneidekunst*. Berlin: Gebr. Mann.
- Moscato, Sabatino  
1961 *Le origini della narrativa storica nell'arte del Vicino Oriente antico*. Memorie, Classe di Scienze morali, storiche e filologiche, Serie 8, Volume 10, Fascicule 2. Roma: Accademia Nazionale dei Lincei.
- Müller-Beck, Hansjürgen, and Gerd Albrecht, (eds.)  
1987 *Die Anfänge der Kunst vor 30000 Jahren*. Stuttgart: Konrad Theiss.
- Müller-Karpe, Michael  
1993 *Metallgefäße im Iraq I (von den Anfängen bis zur Akkad-Zeit)*. Prähistorischer Bronzefunde: Abteilung II, 14. Band. Stuttgart: Franz Steiner.
- Munn-Rankin, Margaret  
1980 "Mesopotamian Chronology: A reply to James Mellaart." *Antiquity* 54:128-129.
- Nagel, Wolfram  
1959 "Datierete Glyptik in fröhdynastischer Zeit." *Orientalia, Nova Series* 28.
- Nakano, Tomoaki  
1998 "Abydos Ware and the Location of the Egyptian First Dynasty Royal Tombs." *Orient* 33:1-32.
- Needler, Winifred  
1984 *Predynastic and Archaic Egypt in the Brooklyn Museum*. Wilbour Monographs 9. New York: Brooklyn Museum.
- Newell, Allen  
1990 *Unified Theories of Cognition*. The William James Lectures 1987. Cambridge, Mass: Harvard University Press.
- Newmeyer, Frederick J.  
1996 [1987] "The Ontogenesis of the Field of Second Language Learning Research," in (ed.) Frederick J. Newmeyer, *Generative Linguistics*. London: Routledge & Kegan Paul.

Nicolopoulou, Ageliki

1997 "The Invention of Writing and the Development of Numerical Concepts in Sumeria: Some implications for developmental psychology," in (eds.) Michael Cole, Yrjö Engström, and Olga Vasquez, *Mind, Culture, and Activity: Seminal papers from the Laboratory of Comparative Human Cognition*:205-225. Cambridge: Cambridge University Press.

Nissen, Hans Jörg

1966 *Zur Datierung des Königsfriedhofes von Ur. Unter besonderer Berücksichtigung der Stratigraphie der Privatgräber*. Beiträge zur ur- und frühgeschichtlichen Archäologie des Mittelmeer-Kulturräumens 3. Bonn: Rudolf Habelt.

1975 "Geographie," in (ed.) Stephen J. Lieberman, *Sumerological Studies in Honor of Thorkild Jacobsen on His Seventieth Birthday: June 7, 1974*:9-40. Assyriological Studies 20. Chicago: University of Chicago Press.

1986a "The Development of Writing and of Glyptic Art," in (eds.) Uwe Finkbeiner and Wolfgang Röllig, *Gamdat Nasr: Period or regional style?*:316-331. Beihefte zum Tübinger Atlas des Vorderen Orients, Reihe B (Geisteswissenschaften) Nr. 62. Wiesbaden.

1986b "The Archaic Texts from Uruk." *World Archaeology* 17:319-333.

1993 "The Context of the Emergence of Writing in Mesopotamia and Iran," in (ed.) John Curtis, *Early Mesopotamia and Iran: Contact and Conflict c. 3500-1600 BC. Proceedings of a seminar in memory of Vladimir G. Lukonin*:54-71. London: British Museum Press.

Nissen, Hans Jörg, Peter Damerow, and Robert K. Englund

1993 *Archaic Bookkeeping: Writing and techniques of economic administration in the ancient Near East*. Chicago: University of Chicago Press.

Noble, William, and Davidson Iain

1996 *Human Evolution, Language and Mind: A psychological and archaeological inquiry*. Cambridge: Cambridge University Press.

Nöldeke, Arnold, Ernst Heinrich, and E. Schott, (eds.)

1934 *Fünfter vorläufiger Bericht über die von der Notgemeinschaft der Deutschen Wissenschaften in Uruk unternommenen Ausgrabungen*, Abhandlungen der Preussischen Akademie der Wissenschaften. Philosophisch-historische Klasse. Jahrg. 1933, 5. Berlin: Akademie der Wissenschaften in Kommission bei W. de Gruyter.

Nöldeke, Arnold, Heinrich J. Lenzen, and Arndt von Haller, (eds.)

1937 *Achter vorläufiger Bericht über die von der Deutschen Forschungsgemeinschaft in Uruk-Warka unternommenen Ausgrabungen*, Abhandlungen der Preussischen Akademie der Wissenschaften. Philosophisch-historische Klasse. Jahrg. 1936, 13. Berlin: Akademie der Wissenschaften in Kommission bei W. de Gruyter.

O'Boyle, Michael W., David A. Miller, and Fahim Rahmani

1987 "Sound-Meaning Relationships in Speakers of Urdu and English: Evidence for a cross-cultural phonetic symbolism." *Journal of Psycholinguistic Research* 16, 3:273-288.

O'Connor, David

1987 "The Earliest Pharaohs and the University Museum." *Expedition* 29, 1:27-39.

1989 "New Funerary Enclosures (Talbezirke) of the Early Dynastic Period at Abydos." *Journal of the American Research Center in Egypt* 26:51-86.

- 1992 "The Status of Early Egyptian Temples," in (eds.) Renée F. Friedman and Barbara Adams, *The Followers of Horus: Studies dedicated to Michael Allen Hoffman 1944-1990*:83-98. Egyptian Studies Association Publication 2. Oxbow Monograph 20. Oxford: Oxbow Books.
- O'Connor, David, and David P. Silverman (eds.)  
1995 *Ancient Egyptian Kingship*. Probleme der Agyptologie 9. Leiden: E. J. Brill.
- Oates, Joan  
1978 "Ubaid Mesopotamia and Its Relation to Gulf Countries," in (ed.) B. De Cardi, *Qatar Archaeological Reports: Excavations 1973*:39-52. Oxford: Oxford University Press.  
1993 "Early Writing in Sumer: A review." *Cambridge Archaeological Journal* 3, 1:149-153.  
1996 "A Prehistoric Communication Revolution. Review of *Archives Before Writing*, edited by Piera Ferioli, Enrica Fiandra, et. al." *Cambridge Archaeological Journal* 6, 1:165-173.
- Oates, Joan, T. E. Davidson, D. Kamilli, et. al.  
1977 "Seafaring Merchants of Ur." *Antiquity* 51:221-234.
- Oates, Joan, and David Oates  
1997 "An Open Gate: Cities of the fourth millennium BC (Tell Brak 1997)." *Cambridge Archaeological Journal* 7, 2:287-307.
- Oberhuber, Karl  
1963 *Der numinose Begriff me im Sumerischen*. Innsbrucker Beiträge zur Kulturwissenschaft Sonderheft 17. Innsbruck: Auslieferung durch das Sprachwissenschaftliche Institut der Leopold-Franzens-Universität.
- Ojoade, J. Olowo  
1994 "Nigerian Cultural Attitudes to the Dog," in (ed.) Roy Willis, *Signifying Animals: Human meaning in the natural world*:215-221. One World Archaeology 16. London: Routledge & Kegan Paul.
- Ong, Walter J.  
1997 [1982] *Orality & Literacy: The technologizing of the world*. New Accents. London: Routledge & Kegan Paul.
- Opficius, Ruth  
1957-1971 "Girsu B. Nach archäologischem Befund," in (ed.) Dietz Otto Edzard, *Reallexikon der Assyriologie (Dritter Band)*:391-401. Berlin und New York: Walter de Gruyter.
- Oppenheim, A. Leo  
1944 "The Significance of the Temple in the Ancient Near East: The Mesopotamian temple." *Biblical Archaeologist* 7:54-63.  
1954 "The Seafaring Merchants of Ur." *Journal of the American Oriental Society* 74:6-17.  
1956 *The Interpretation of Dreams in the Ancient Near East: With a translation of an Assyrian dream-book*. Transactions of the American Philosophical Society, New Series 46 (3). Philadelphia: The American Philosophical Society.

- 1957 "A Bird's-Eye View of Mesopotamian Economic History," in (eds.) K. Polanyi, C. M. Arensberg, and H. W. Pearson, *Trade and Market in the Early Empires: Economics in History and Theory*:27-37. Glenco, Illinois: Free Press; Falcon Wing Press.
- 1959 "On an Operational Device in Mesopotamian Bureaucracy." *Journal of Near Eastern Studies* 18, 2:121-128.
- 1969 "New Fragments of the Assyrian Dream-book." *Iraq* 31:153-169.
- 1977 *Ancient Mesopotamia: Portrait of a dead civilization (2nd. rev ed.)*. (ed.) Erica Reiner. Chicago: University of Chicago Press.
- Oren, Elezer, and Yuval Yeutieli
- 1992 "Taur Ikhbeineh: Earliest evidence for Egyptian interconnections," in (ed.) Edwin C. M. van den Brink, *The Nile Delta in Transition: 4th - 3rd Millennium B.C.. Proceedings of a Seminar Held in Cairo, 21. - 24 October 1990, at the Netherlands Institute of Archaeology and Arabic Studies*:361-384. Tel Aviv: Distributed by the Israel Exploration Society for Edwin C. M. van den Brink.
- Origgi, Gloria, and Dan Sperber
- 2000 "Evolution, Communication and the Proper Function of Language," in (eds.) Peter Carruthers and Andrew Chamberlain, *Evolution and the Human Mind: Modularity. language and meta-cognition*:140-169. Cambridge: Cambridge University Press.
- Orthmann, Winfried
- 1975 *Der alte Orient*. Propyläen Kunstgeschichte Band 14. Berlin: Propyläen Verlag.
- Ortony, Andrew, (ed.)
- 1996 *Metaphor and Thought*. Cambridge: Cambridge University Press.
- Osherson, Daniel N., and Howard Lasnik, (eds.)
- 1990 *Language. An Invitation to Cognitive Science: Volume 1*. Cambridge, Massachusetts: MIT Press.
- Otto, Rudolf
- 1950 [1926] *The Idea of the Holy: An inquiry Into the non-rational factor in the idea of the divine and its relation to the rational*. Translated by John W. Harvey. London: Oxford University Press.
- Paffrath, Tharsicius
- 1913 *Zur Götterlehre in den altbabylonischen Königsinschriften: mit einem ausführlichen Register der auf die altbabylonische Götterlehre bezüglichen Stellen*. Studien zur Geschichte und Kultur des Altertums 6. Paderborn: F. Schöningh.
- Pallis, Svend Aage
- 1956 *The Antiquity of Iraq: A handbook of assyriology*. Copenhagen: E. Munksgaard.
- Panofsky, Erwin
- 1972 *Studies in Iconology: Humanistic themes in the art of the renaissance*. New York: Harper and Row.
- Parpola, Asko, and Simo Parpola
- 1975 "On the relationship of the Sumerian Toponym Meluhha and Sanskrit Mleccha." *Studia Orientalia* 16:205-238.

Parrot, André

- 1932 "Fouilles de Tello: Campagne 1931-1932 (rapport préliminaire)." *Revue d'assyriologie et d'archéologie orientale* 29, 2:45-57.
- 1933 "Les fouilles de Tello et de Senkereh-Larsa: Campagne 1932-1933 (rapport préliminaire)." *Revue d'assyriologie et d'archéologie orientale* 30, 3:169-182.
- 1948 *Tello: Vingt campagnes de fouilles (1877-1933)*. Paris: Éditions Albin Michel.
- 1954 *Glyptique Mésopotamienne: fouilles de Lagash (Tello) et de Larsa (Senkereh) (1931- 1933)*. (ed.) Maurice Lambert. Paris: Imprimerie Nationale/Librarie Orientaliste Paul Geuthner.
- 1960 *Sumer. The Arts of Mankind*. London: Thames and Hudson.
- 1969 *Sumer-Assur: Ergänzung*. Universum des Kunst. Munich: C. H. Beck.

Payne, Joan Crowfoot

- 1968 "Lapis Lazuli in Early Egypt." *Iraq* 30:58-61.
- 1973 "Tomb 100: The decorated tomb at Hierakonpolis confirmed." *Journal of Egyptian Archaeology* 59:31-35.
- 1990 "The Chronology of Predynastic Egyptian Decorated Ware." *Eretz-Isreal* 21:77-82.
- 1993 *Catalogue of the Predynastic Egyptian Collection in the Ashmolean Museum*. Oxford: Oxford University Press.

Peck, James, (ed.)

- 1987 *The Chomsky Reader*. London: Serpent's Tail.

Peck, William H.

- 1985 "Review of *Excavations at Tell Basta: Report of seasons 1967-1971 and catalogue of finds* by Ahmad el-Sawi." *Journal of Near Eastern Studies* 44, 3:227-235.

Peirce, Charles S.

- 1991 *Peirce on Signs: writings on semiotic by Charles Sanders Peirce*. (ed.) James Hoopes. Chapel Hill: University of North Carolina Press.

Pelzel, Suzanne Meek

- 1973 *Perforated Sumerian Votive Plaques*. Ph.D. dissertation, New York University.

Perkins, Ann Louise

- 1957 "Narration in Babylonian Art." *American Journal of Archaeology* 61:54-62, Pls. 17-20.

Perrot, Georges, Charles Chipiez, and Walter Armstrong

- 1884 *History of Art in Chaldaea and Assyria* (2 Vols.). London: Chapman and Hall.

Peterson, Mary A.

- 1999 "High-Level Vision," in (eds.) Robert A. Wilson and Frank C. Keil, *The MIT Encyclopedia of the Cognitive Sciences*:374-376. A Bradford Book. Cambridge, Massachusetts: MIT Press.

Petrie, W. M. Flinders

- 1896 *Koptos*. London: B. Quaritch.

- 1900 *The Royal Tombs of the First Dynasty, Part I*. The Egypt Exploration Fund Memoirs 18. London: Kegan Paul, Trench, Trübner and Co.
- 1901a *The Royal Tombs of the Earliest Dynasties, Part II*. The Egypt Exploration Fund Memoirs 21. London: Kegan Trench, Trübner and Co.
- 1901b *Diospolis Parva: The cemeteries of Abadiyeh and Hu, 1898-9*. The Egypt Exploration Fund Memoirs 20. London: Kegan Paul, Trench, Trübner and Co.
- 1901c *The Royal Tombs of the Earliest Dynasties: Part II (Extra Plates)*. The Egypt Exploration Fund (Special Extra Publication). London: Kegan Paul, Trench, Trübner and Co.
- 1902 *Abydos: Part I*. The Egypt Exploration Fund Memoirs 22. London: Kegan Paul, Trench, Trübner and Co.
- 1903 *Abydos: Part II*. The Egypt Exploration Fund Memoirs 24. London: Kegan Paul, Trench, Trübner and Co.
- 1914 *Tarkhan II*. British School of Archaeology in Egypt and Egyptian Research Account 26. London: Bernard Quartich.
- 1917 *Prehistoric Egypt*. British School of Archaeology in Egypt and Egyptian Research Account 31. London: Bernard Quartich.
- 1921 *Corpus of Prehistoric Pottery and Pallettes*. British School of Archaeology in Egypt and Egyptian Research Account 32. London: Bernard Quartich.
- 1939 *The Making of Egypt*. London: Sheldon Press.
- 1953 *Ceremonial Slate Palettes*. British School of Archaeology in Egypt and Egyptian Research Account 66. London: Bernard Quartich.
- Petrie, W. M. Flinders, and J. E. Quibell  
1896 *Naqada and Ballas*. British School of Archaeology in Egypt and Egyptian Research Account 1. London: Bernard Quartich.
- Petrie, W. M. Flinders, G. A. Wainwright, and A. H. Gardiner  
1913 *Tarkhan I and Memphis V*. British School of Archaeology in Egypt and Egyptian Research Account 23. London: Bernard Quartich.
- Pettinato, Giovanni  
1970-1971 "I<sub>7</sub>-Idigna-ta I<sub>7</sub>-nunšè: Il conflitto tra Lagaš ed Umma per la 'Frontera Divina' e la sua soluzione durante la terza dinastia di Ur." *Mesopotamia* 5/7:281-320.
- Pfeiffer, John E.  
1982 *The Creative Explosion: An inquiry into the origins of art and religion*. New York: Harper and Row.
- Piattelli-Palmarini, Massimo, (ed.)  
1980 *Language and Learning: The debate between Jean Piaget and Noam Chomsky*. London: Routledge & Kegan Paul.
- Pinker, Steven  
1994 *The Language Instinct: How the mind creates language*. New York: William Morrow and Company.
- Pinker, Steven, and Paul Bloom  
1992 "Natural Language and Natural Selection," in (eds.) Jerome H. Barkow, Leda Cosmides, and John Tooby, *The Adapted Mind: Evolutionary psychology and the generation of culture*:451-494. Oxford: Oxford University Press.

## Pittman, Holly

1994a *The Glazed Steatite Style: The structure and function of an image system in the administration of protoliterate Mesopotamia*. Berliner Beiträge zum Vordern Orient 16. Berlin: Dietrich Reimer Verlag.

1994b "The 'Shell' Pendant in the States Museum in Berlin: Egypt or the ancient Near East?" *Source: Notes in the History of Art* 4:28-35.

1994c "Towards an Understanding of the Role of Glyptic Imagery in the Administrative Systems of Proto-Literate Greater Mesopotamia," in (ed.) Piera Ferioli, *Archives Before Writing: Proceedings of the International Colloquium, Oriolo Romano, October 23-25, 1991*:177-205. Turin: Scriptorium.

1996 "Constructing Context: The Gebel el-Arak Knife - Greater Mesopotamian and Egyptian Interaction in the Late Fourth Millennium B.C.E.," in (eds.) Jerrold S. Cooper and Glenn M. Schwartz, *The Study of the Ancient Near East in the Twenty First Century: The William Foxwell Albright Centennial conference*:9-32. Winona Lake, Indiana: Eisenbrauns.

## Podzorski, Patricia V.

1988 "Predynastic Egyptian Seals of Known Provenience in the R. H. Lowie Museum of Anthropology." *Journal of Near Eastern Studies* 47:259-268.

## Poebel, Arno

1914 *Historical Texts*. Publications of the Babylonian Section) 4,1. Philadelphia: University Museum.

1923 *Grundzüge der Sumerischen Grammatik*. Rostocker Orientalische Studien I. Selbstverlag des Verfassers.

1926 "Der Konflikt zwischen Lagaš und Umma zur Zeit Enannatums I und Entemenas," in (eds.) Cyrus Adler and Aaron Ember, *Oriental Studies Published in Commemoration of the Fortieth Anniversary (1883-1923) of Paul Haupt as Director of the Oriental Seminary of the Johns Hopkins University, Baltimore, Md*. Baltimore: Johns Hopkins Press.

## Pollock, Susan

1983 *The Symbolism of Prestige: An archaeological example from the Royal Cemetery at Ur*. Ph.D. dissertation, University of Michigan.

## Porada, Edith

1948 *Corpus of Ancient Near Eastern Seals in North American Collections: The collection of the Pierpont Morgan Library*. Bollingen Series 14. Washington, D.C.: Bollingen.

1956 "Review of *The Birth of Civilization in the Near East and Art and Architecture in the Ancient Orient* by Henry Frankfort." *Art Bulletin* 38:121-124.

1965 "The Relative Chronology of Ancient Mesopotamia. Part I. Seals and Trade (6000-1600 B.C.)," in (ed.) Robert W. Ehrich, *Chronologies in Old World Archaeology*:133- 181. Chicago: University of Chicago Press.

1980 "A Lapis Lazuli Figurine from Hierakonpolis in Egypt." *Iranica Antiqua* 15.

1989 "A Footnote to Rudi Wittkower's Eagle and Serpent." *Source: Notes in the History of Art* 8-9, 4/1.

- Porada, Edith, Donald P. Hansen, Sally Dunham, *et. al.*  
 1992a "The Chronology of Mesopotamia, ca. 7000-1600 B.C.," in (ed.) Robert W. Ehrich, *Chronologies in Old World Archaeology: Volume I:77-121*. Chicago: University of Chicago Press.  
 1992b "Mesopotamia," in (ed.) Robert W. Ehrich, *Chronologies in Old World Archaeology: Volume II:90-124*. Chicago: University of Chicago Press.
- Porat, Naomi  
 1992 "An Egyptian Colony in Southern Palestine During the Late Predynastic - Early Dynastic Period," in (ed.) Edwin C. M. van den Brink, *The Nile Delta in Transition: 4th - 3rd Millennium B.C.. Proceedings of a Seminar Held in Cairo, 21. - 24 October 1990, at the Netherlands Institute of Archaeology and Arabic Studies:433-441*. Tel Aviv: Distributed by the Israel Exploration Society for Edwin C. M. van den Brink.
- Posener-Kriéger, Paule, (ed.)  
 1985 *Mélanges Gamal Eddin Mokhtar* (2 Vols.). Edited by Institut français d'archéologie orientale du Caire. Bibliothèque d'étude. Institut français d'archéologie orientale du Caire 97. Cairo: Institut français d'archéologie orientale du Caire.
- Postgate, J. Nicholas  
 1982 "Abu Salabikh," in (ed.) John Curtis, *Fifty Years of Mesopotamian Discovery: The work of the British School of Archaeology in Iraq 1932 - 1982:48-61*. London: British School of Archaeology in Iraq.  
 1984 "Excavations at Abu Salabikh, 1983." *Iraq* 45:95-115.  
 1990 "Excavations at Abu Salabikh, 1988-1989." *Iraq* 52:95-107.  
 1992 *Early Mesopotamia: Society and economy at the dawn of history*. London and New York: Routledge & Kegan Paul.  
 1994 "Text and Figure in Ancient Mesopotamia: Match and mismatch," in (eds.) Colin Renfrew and Ezra B. Zubrow, *The Ancient Mind: Elements of cognitive archaeology:176-184*. New Directions in Archaeology. Cambridge: Cambridge University Press.  
 1997 "Mesopotamian Petrology: Stages in the classification of the material world." *Cambridge Archaeological Journal* 7, 2:205-224.
- Postgate, J. Nicholas , Roger J. Matthews, Tao Wang, *et. al.*  
 1995 "The Evidence for Early Writing: Utilitarian or ceremonial?" *Antiquity* 69:459-480.
- Postgate, J. Nicholas, and J. A. Moon  
 1980 "Excavations at Abu Salabikh, 1978-1979." *Iraq* 42, 2:87-104.
- Postgate, J. Nicholas, and P. R. S. Moorey  
 1976 "Excavations at Abu Salabikh, 1975." *Iraq* 38, 2:133-170.
- Postgate, J. Nicholas, and J. E. Reade  
 1976 "Kalḫu," in (ed.) Ernst and Wolfram von Soden Weidner, *Reallexikon der Assyriologie (Fünfter Band):303-323*. Berlin und New York: Walter de Gruyter.
- Potts, Daniel T., (ed.)  
 1983 *Dilmun: New studies in the archaeology and early history of Bahrain*, Berliner Beiträge zum Vordern Orient 2. Berlin: Dietrich Reimer.

- 1990 *The Arabian Gulf in Antiquity. Volume I: From prehistory to the fall of the Achaemenid empire.* Oxford: Clarendon Press.
- 1997 *Mesopotamian Civilization: The material foundations.* Ithaca: Cornell University Press.
- Potts, Timothy F.
- 1994 *Mesopotamia and the East: An archaeological and historical study of foreign relations 3400-2000 BC.* Oxford University Committee for Archaeology Monograph 37. Oxford: Oxford University Committee for Archaeology Institute of Archaeology.
- Powell, Marvin A.
- 1981 "Three Problems in the History of Cuneiform Writing: Origins, direction of script, literacy." *Visible Language* 15:419-441.
- 1995 "Metrology and Mathematics in Ancient Mesopotamia," in (ed.) Jack M. Sasson, *Civilizations of the Ancient Near East III:1941-1957.* New York: Scribner's.
- Prag, Kay
- 1986 "Byblos and Egypt in the Fourth Millennium B.C." *Levant* 18:59-74.
- Premack, David, and Ann Premack
- 2003 *Original Intelligence: Unlocking the mystery of who we are.* New York: McGraw Hill.
- Preziosi, Donald
- 1989 *Rethinking Art History: Meditations on a coy science.* New Haven: Yale University Press.
- Prince, Gerald
- 1987 *Dictionary of Narratology.* Lincoln: University of Nebraska Press.
- Putnam, Hilary
- 1975 *Mind, Language, and Reality. Philosophical Papers, Volume II.* Cambridge: Cambridge University Press.
- 1995 *Reason, Truth, and History.* Cambridge: Cambridge University Press.
- Quarantelli, Ezio
- 1985 *The Land Between Two Rivers: Twenty years of Italian archaeology. The Treasures of Mesopotamia.* El Quadrante Edizioni.
- Quibell, J. E.
- 1900 *Hierakonpolis I.* Egyptian Research Account 4. London: Bernard Quaritch.
- 1904 *Archaic Objects: II.* Catalogue Général des Antiquités Égyptienne du Musée du Caire: Nos. 11001-12000 et 14001-14754 XXIV. Cairo: Institut français d'archeologie.
- 1905 *Archaic Objects: I.* Catalogue Général des Antiquités Égyptienne du Musée du Caire: Nos. 11001-12000 et 14001-14754 XXIII. Cairo: Institut français d'archeologie.
- Quibell, J. E., and F. W. Green
- 1902 *Hierakonpolis II.* Egyptian Research Account 5. London: Bernard Quaritch.

Ranke, Hermann

1905 *Early Babylonian Personal Names from the Published Tablets of the so-called Hammurabi Dynasty (B.C. 2000)*. Babylonian Expedition of the University of Pennsylvania, Series D; Researches and Treatises 3. Philadelphia: University of Pennsylvania Press.

Rashad, Mahmoud

1990 *Die entwicklung der vor- und frühgeschichtlichen Stempelsiegel in Iran: Im vergleich mit Mesopotamien, Strien und Kleinasien - von ihren anfangen bis zum beginn des 3. Jahrtausends v.Chr.* Archaeologische Mitteilungen aus Iran / Herausgegeben vom Deutsches Archäologischen Institute- Abteilungen Tehran, Ergänzungsband 13. Berlin: Dietrich Reimer.

Rashid, Subhi Anwar

1957-1971 "Gründungsbeigaben," in (ed.) D. O. Edzard, *Reallexikon der Assyriologie (Dritter Band)*:655-661. Berlin und New York: Walter de Gruyter.  
1983 *Gründungsfiguren im Iraq*. Prähistorischer Bronzefunde: Abteilung I, 2. Band. Munich: C. H. Beck.

Rassam, Hormuzd

1971 [1897] *Asshur and the land of Nimrod: Being an account of the discoveries made in the ancient ruins of Nineveh, Asshur, Sepharvaim, Calah, Babylon, Borsippa, Cuthah, and Van, including a narrative of different journeys in Mesopotamia, Assyria, Asia Minor, and Koordistan*. New York: Eaton & Mains.

Ratnagar, Shereen

1981 *Encounters: The westerly trade of the Harappa civilization*. Delhi: Oxford University Press.

Ray, John D.

1986 "The Emergence of Writing in Egypt." *World Archaeology* 17:307-316.

Reade, Julian E.

1997 "Sumerian Origins," in (eds.) I. L. Finkel and M. J. Geller, *Sumerian Gods and Their Representations*:221-229. Cuneiform Monographs 7. Groningen: Styx.

Reddy, Michael J.

1996 "The Conduit Metaphor: A case of frame conflict in our language about language," in (ed.) Andrew Ortony, *Metaphor and Thought*:164-201. Cambridge: Cambridge University Press.

Reisman, Daniel

1972 "Ninurta's Journey to Eridu." *Journal of Cuneiform Studies* 24, 1-2:3-10.

Renfrew, Colin

1994 "Towards a Cognitive Archaeology," in (eds.) Colin Renfrew and Ezra B. Zubrow, *The Ancient Mind: Elements of cognitive archaeology*:3-13. New Directions in Archaeology. Cambridge: Cambridge University Press.

- 1999 "Mind and Matter: Cognitive archaeology and external symbolic storage," in (eds.) Colin Renfrew and Chris Scarre, *Cognition and Material Culture: The archaeology of symbolic storage*:1-6. McDonald Institute Monographs. Cambridge: McDonald Institute for Archaeological Research.
- Renfrew, Colin, and Chris Scarre, (eds.)  
1999 *Cognition and Material Culture: The archaeology of symbolic storage*, McDonald Institute Monographs. Cambridge: McDonald Institute for Archaeological Research.
- Renfrew, Colin, and Ezra B. Zubrow, (eds.)  
1994 *The Ancient Mind: Elements of cognitive archaeology*, New Directions in Archaeology. Cambridge: Cambridge University Press.
- Renger, Johannes M.  
1991 "Wirtschaft und Gesellschaft," in (ed.) Barthel Hrouda, *Der alte Orient: Geschichte und Kultur des alten Vorderasien*:187-216. Munich: C. Bertelsmann.  
1995 "Institutional, Communal, and Individual Ownership or Possession of Arable Land in Ancient Mesopotamia from the End of the Fourth to the End of the First Millennium B.C." *Chicago-Kent Law Review* 71, 1:269-319.
- Richter, Thomas, Doris Prechel, and Jörg Klinger, (eds.)  
2001 *Kulturgeschichten: Altorientalistische Studien für Volkert Haas zum 65. Geburtstag*. Saarbrücken: SDV Saarbrücker Druckerei und Verlag.
- Roaf, Michael  
2001 "Doubts About the Two-Lobed Burial and the Survival of Early Dynastic to Akkadian Transitional Building Levels in Area WF at Nippur." *Iraq* 63:55-66.
- Robichon, C., and A. Varille  
1940 *Description sommaire du temple primitif de Médamud*. Recherches d'Archéologie, de Philologie et d'Histoire XI. Cairo: Institut Française d'Archéologie Orientale.
- Römer, W. H., (ed.)  
1999 *Die Sumerologie: Einführung in die Forschung und Bibliographie in Auswahl* (zweite, erweiterte Auflage), *Alter Orient und Altes Testament* 262. Münster: Ugarit-Verlag.
- Rosch, Eleanor  
1973 "Natural Categories." *Cognitive Psychology* 4:328-350.  
1975a "Cognitive Reference Points." *Cognitive Psychology* 7:532-547.  
1975b "Cognitive Representations of Semantic Categories." *Journal of Experimental Psychology: General* 104:192-233.  
1975c "Structural Bases of Typicality Effects." *Journal of Experimental Psychology: Human perception and performance* 2:491-502.  
1975d "The Nature of Mental Codes for Color Categories." *Journal of Experimental Psychology: Human perception and performance* 2:303-322.  
1978 "Principles of Categorization," in (eds.) Eleanor Rosch and Barbara B. Lloyd, *Cognition and Categorization*:27-48. Hillsdale, N.J: Lawrence Erlbaum Associates.

- Rosch, Eleanor, and Barbara B. Lloyd, (eds.)  
1978 *Cognition and Categorization*. Hillsdale, N.J: Lawrence Erlbaum Associates.
- Rosch, Eleanor, and Carolyn B. Mervis  
1975 "Family Resemblances: Studies in the internal structure of categories." *Cognitive Psychology* 7:573-605.
- Rosch, Eleanor, Carolyn B. Mervis, Wayne Gray, *et. al.*  
1976 "Basic Objects in Natural Categories." *Cognitive Psychology* 8:382-439.
- Rosengarten, Yvonne  
1960 *Le régime des offrandes dans la société sumerienne d' après les textes presargoniques de Lagas*. Paris: Éditions E. de Boccard.
- Rowlands, Michael  
1987 "Centre and Periphery: A review of a concept," in (eds.) Michael Rowlands, Mogens Trolle Larsen, and Kristian Kristiansen, *Centre and Periphery in the Ancient World*:1-11. New Directions in Archaeology. Cambridge: Cambridge University Press.
- Rowlands, Michael, Mogens Trolle Larsen, and Kristian Kristiansen  
1987 *Centre and Periphery in the Ancient World*. New Directions in Archaeology. Cambridge: Cambridge University Press.
- Rozin, Paul  
1976 "The Evolution of Intelligence and Access to the Cognitive Unconscious." *Progress in Psychobiology and Physiological Psychology* 6:245-280.
- Rubio, Gonzalo  
1999 "On the Alleged Pre-Sumerian Substratum." *Journal of Cuneiform Studies* 51:1-16.
- Russell, John Malcolm  
1991 *Sennacherib's "Palace Without Rival" at Nineveh*. Chicago: University of Chicago Press.  
1993 "Sennacherib's Lachish Narratives," in (ed.) Peter J. Holliday, *Narrative and Event in Ancient Art*. Cambridge: Cambridge University Press.
- Safar, Fuad  
1949 "The Identification of Dudu." *Sumer* 5, 2:133-135.  
1950 "Excavations at Eridu - Third Season." *Sumer* 6:27-38.
- Safar, Fuad, Mohammad Ali Moustafa, and Seton Lloyd  
1981 *Eridu*. Baghdad: Republic of Iraq, Ministry of Culture and Information, State Organization of Antiquities and Heritage.
- Salim, S. M.  
1962 *Marsh Dwellers of the Euphrates Delta*. London School of Economics Monographs on Social Anthropology 23. London: University of London.

## Sallaberger, Walther

- 1993 *Der kultische Kalender der Ur III-Zeit* (2 Vols.). Untersuchungen zur Assyriologie und vorderasiatischen Archäologie 7. Berlin: de Gruyter.
- 1994 "Review of *Neo-Sumerian texts from Umma and Other Sites* by Philip J. Watson." *Orientalistische Literaturzeitung* 89, 4/5:538-545.

## Salonen, Armas

- 1966 *Die Hausgeräte der alten Mesopotamier nach sumerisch-Akkadischen Quellen. Teil II: Gefässe.* Annales Academiae Scientiarum Fennicae: Sarja B 139. Helsinki: Suomalaisen Tiedeakatemian Toimituskia.
- 1968 *Agricultura Mesopotamica: Nach sumerisch-Akkadischen Quellen. Eine lexikalische und kulturgeschichtliche Untersuchung.* Annales Academiae Scientiarum Fennicae: Sarja B 149. Helsinki: Suomalaisen Tiedeakatemian Toimituskia.
- 1969 *Die Fussbekleidung der alten Mesopotamien nach sumerisch-Akkadischen Quellen.* Annales Academiae Scientiarum Fennicae: Sarja B 157. Helsinki: Suomalaisen Tiedeakatemian Toimituskia.
- 1972 *Die Ziegeleien im alten Mesopotamien.* Annales Academiae Scientiarum Fennicae: Ser B 171. Helsinki: Suomalaisen Tiedeakatemian Toimituskia.
- 1973 *Vogel und Vogelfang in alten Mesopotamien.* Annales Academiae Scientiarum Fennicae: Ser B 180. Helsinki: Suomalaisen Tiedeakatemian Toimituskia.
- 1976 *Jagd und Jagdtiere im alten Mesopotamien.* Suomalaisen Tiedeakatemian Toimituksia. Sarja B; 196. Helsinki: Suomalainen Tiedeakatemia.

## Samuels, Richard

- 2000 "Massively Modular Minds: Evolutionary psychology and cognitive architecture," in (eds.) Peter Carruthers and Andrew Chamberlain, *Evolution and the Human Mind: Modularity, language and meta-cognition*:13-46. Cambridge: Cambridge University Press.

## Sapir, Edward

- 1921 *Language: An introduction to the study of speech.* San Diego: Harcourt Brace & Company.
- 1949 *Selected Writings of Edward Sapir in Language, Personality, and Culture.* Berkeley and Los Angeles: University of Los Angeles Press.

## Saporetti, Claudio

- 1990 *Etana.* Palermo: Sellerio Editore.

## Sarzec, Gustave Charles Ernest Choquin de

- 1893 "Textes Sumériens tres antiques découverts par M. de Sarzec." *Revue d'assyriologie et d'archéologie orientale* 3, 1:31-32.

## Sarzec, Gustave Charles Ernest Choquin de, and Leon Heuzey

- 1884-1912 *Découvertes en Chaldée.* Paris: E. Leroux.
- 1899 "Construction antérieure a Our-Nina." *Revue d'assyriologie et d'archéologie orientale* 5, 2:33-56.

## Sasim, Sabah Abboud, and Joan Oates

- 1986 "Early Tokens and Tablets in Mesopotamia: New information from Tell Abada and Tell Brak." *World Archaeology* 17, 348-362.

- Sasson, Jack M., (ed.)  
1995 *Civilizations of the Ancient Near East (4 Volumes)*. New York: Scribner's.
- Saussure, Ferdinand de  
1966 *Course in General Linguistics*. New York: McGraw Hill Book Company.
- Savage, Stephen H.  
1998 "AMS Radiocarbon Dates from the Predynastic Egyptian Cemetery, at Naga-ed-Dêr." *Journal of Archaeological Science* 25, 3:235-249.
- Sawi, Ahmad el  
1979 *Excavations at Tell Basta: Report of seasons 1967-1971 and catalogue of finds*. Prague: Charles University.
- Scamuzzi, Ernesto  
1965 *Egyptian Art in the Egyptian Museum of Turin*. New York: Harry N. Abrams.
- Schacter, Daniel L.  
1989 "On the Relation Between Memory and Consciousness: Dissociable interactions and conscious experience," in (eds.) Henry L Roedinger and Fergus I. M. Craik, *Variety of Memory and Consciousness: Essays in Honor of Endel Tulving*:355-389. Hillsdale, New Jersey: Lawrence Erlbaum Associates.
- Schäfer, Heinrich  
1986 (rev. ed.) *Principles of Egyptian Art*. Translated by John Baines. Oxford: Griffith Institute.
- Schäfer, Heinrich, and Walter Andrae  
1925 *Die Kunst des alten Orients*. Propyläen Kunstgeschichte 2 (Old Series). Berlin: Propyläen-Verlag.
- Schapiro, Meyer  
1994 *Theory and Philosophy of Art: Style artist and society*. Selected Papers 4. New York: George Braziller.  
1994 [1953] "Style (with Bibliography)," *Theory and Philosophy of Art: Style Artist and Society*:51-103. New York: George Braziller.  
1994 [1969] "On Some Problems in the Semiotics of Visual Art: Field and vehicle in image-signs," *Theory and Philosophy of Art: Style Artist and Society*:1-32. New York: George Braziller.  
1996 "Words, Script, and Pictures: Semiotics of visual language." New York: George Braziller.
- Schauensee, Maude de  
2002 *Two Lyres from Ur*. Philadelphia: University of Pennsylvania Museum of Archaeology and Anthropology.
- Schele, Linda, and Mary Ellen Miller  
1986 *The Blood of Kings: Dynasty and ritual in Maya art*. New York: George Braziller.

Schieffelin, Bambi B., Kathryn A. Woolard, and Paul V. Kroskrity, (eds.)

1998 *Language Ideologies: Practice and theory*, Oxford Studies in Anthropological Linguistics 16. Oxford.

Schmandt-Besserat, Denise

1977 "An Archaic Recording System and the Origin of Writing." *Syro-Mesopotamian Studies* 1, 2.

1983 "The Earliest Precursor of Writing," in (ed.) Brian Fagan, *Prehistoric Times*:194-203. Readings from Scientific American. San Francisco: W. H. Freeman and Company.

1989 "Two Precursors of Writing: Plain and complex tokens," in (ed.) Wayne M. Senner, *The Origins of Writing*:27-42. Lincoln, Nebraska: University of Nebraska Press.

1992a *Before Writing. Volume 1: From counting to cuneiform*. Austin: University of Texas Press.

1992b *Before Writing. Volume 2: A catalogue of Near Eastern tokens*. Austin: University of Texas Press.

1993 "Images of Enship," in (eds.) M. Frangipane and et. al., *Between the Rivers and Over the Mountains: Archaeologica anatolica et mesopotamica Alba Palmeieri dedicata*:201-219. Rome.

1996 *How Writing Came About*. Austin: University of Texas Press.

Schmidt, Jürgen, (ed.)

1972 *XXVI. und XXVII. vorläufiger Bericht über die von dem Deutschen Archäologischen Institut und der Deutschen Orient-Gesellschaft aus Mitteln der Deutschen Forschungsgemeinschaft unternommenen Ausgrabungen in Uruk-Warka: 1968 und 1969*, Abhandlungen der Deutschen Orient-Gesellschaft 16. Berlin: Gebr. Mann.

1978 "Tell Mismar, ein prähistorischer Fundort im Südiraq." *Baghdader Mitteilungen* 9:10-11.

Schneider, Nikolaus

1939 *Die Götternamen von Ur III: (Ur III-Lexikon. Teil 1)*. Analecta orientalia 19. Roma: Pontificium Institutum Biblicum.

Schott, Siegfried

1951 *Hieroglyphen: Untersuchungen zum Ursprung der Schrift*. (ed.) Literatur Geistes- und Sozialwissenschaftliche Akademie der Wissenschaften und der, Klasse 24. Wiesbaden: Akademie der Wissenschaften und der Literatur.

Schulman, Alan R.

1992 "Still More Egyptian Seal Impressions From 'En Besor," in (ed.) Edwin C. M. van den Brink, *The Nile Delta in Transition: 4th - 3rd Millennium B.C.. Proceedings of a Seminar Held in Cairo, 21. - 24 October 1990, at the Netherlands Institute of Archaeology and Arabic Studies*:395-417. Tel Aviv: Distributed by the Israel Exploration Society for Edwin C. M. van den Brink.

Schwartz, Glenn M.

1986 "Mortuary Evidence and Social Stratification in the Ninevite V Period," in (ed.) Harvey Weiss, *The Origins of Cities in Dry-Farming Syria and Mesopotamia in the Third Millennium B.C.*:45-60. Guilford, Connecticut: Four Quarters.

- Scribner, Sylvia, and Michael Cole  
 1981 *The Psychology of Literacy*. Cambridge, Massachusetts: Harvard University Press.
- Searle, John R.  
 1995a *Speech Acts: An essay in the philosophy of language*. Cambridge: Cambridge University Press.  
 1995b *The Construction of Social Reality*. New York: The Free Press.
- Seele, Keith E.  
 1974 "University of Chicago Expedition: Excavations between Abu Simbel and the Sudan border, preliminary report." *Journal of Near Eastern Studies* 33:1-43.
- Segal, Erwin M.  
 1994 "Archaeology and Cognitive Science," in (eds.) Colin Renfrew and Ezra B. Zubrow, *The Ancient Mind: Elements of cognitive archaeology*:22-29. New Directions in Archaeology. Cambridge: Cambridge University Press.
- Seidel, Matthias, and Dietrich Wildung  
 1975 "Rundplastik der Frühzeit und des alten Reiches," in (ed.) Claude Vandersleyen, *Das alten Ägypten*. Propyläen Kunstgeschichte 17. Berlin: Propyläen Verlag.
- Selz, Gebhard J.  
 1989 *Altsumerische Verwaltungstexte aus Lagaš: Die altsumerischen Wirtschaftsurkunden der Ermitage zu Leningrad*. Freiburger Altorientalische Studien 15,1. Wiesbaden: Franz Steiner Verlag GmbH.  
 1990 "Studies in Early Syncretism: The Development of the pantheon in Lagaš. Examples for Inner-Sumerian Syncretism." *Acta Sumerologica* 12:111-142.  
 1992 "Enlil und Nippur nach präargonischen Quellen," in (ed.) Maria de Jong Ellis, *Nippur at the Centennial: Papers Read at the 35e Rencontre Assyriologique Internationale, Philadelphia, 1988*:189-126. Occasional Publications of the Samuel Noah Kramer Fund 14. Philadelphia: University Museum.  
 1993a *Altsumerische Verwaltungstexte aus Lagaš, Teil 2: Die altsumerischen Wirtschaftsurkunden aus amerikanischen Sammlungen. 1. Abschnitt, Einleitung: Texte aus dem Harvard Semitic Museum*. Freiburger Altorientalische Studien 15,2. Wiesbaden: Franz Steiner Verlag GmbH.  
 1993b *Altsumerische Verwaltungstexte aus Lagaš, Teil 2: Die altsumerischen Wirtschaftsurkunden aus amerikanischen Sammlungen. 2. Abschnitt. Texte aus: Free Library Philadelphia, Yale University Babylonian Section*. Freiburger Altorientalische Studien 15,2. Wiesbaden: Franz Steiner Verlag GmbH.  
 1993 "Beobachtungen zur 'Silbervase' des Entemena." *Aula Orientalis*, 11:107-111.  
 1995 *Untersuchungen zur Götterwelt des altsumerischen Stadtstaates von Lagaš*. Occasional publications of the Samuel Noah Kramer Fund 13. Philadelphia: University of Pennsylvania Museum.  
 1997 "'The Holy Drum, the Spear and the Harp' Towards an Understanding of the Problems of Deification in Third Millennium Mesopotamia," in (eds.) I. L. Finkel and M. J. Geller, *Sumerian Gods and Their Representations*:167-213. Cuneiform Monographs 7. Groningen: Styx.  
 1998a "Die Etana-Erzählung. Ursprung und Tradition eines der ältesten epischen Texte in einer semitischen Sprache." *Acta Sumerologica* 20:135-179.

- 1998b "Über Mesopotomische Herrschaftskonzepte. Zu den Ursprüngen mesopotamischer Herrscherideologie im 3. Jahrtausend," in (eds.) Thomas E. Balke, Manfred Dietrich, and Oswald Loretz, *Dubsar anta-men : Studien zur Altorientalistik : Festschrift für Willem H. Ph. Römer zur Vollendung seines 70. Lebensjahres, mit Beiträgen von Freunden, Schülern und Kollegen*:281-344. Alter Orient und Altes Testament 253. Münster: Ugarit-Verlag.
- 1999 "Vom 'vergangenen Geschehen' zur 'Zukunftsbewältigung' Überlegungen zur Rolle der Schrift in Ökonomie und Geschichte," in (eds.) Barbara Bock, Eva Christiane Cancik-Kirschbaum, and Thomas Richter, *Munuscula Mesopotamica: Festschrift für Johannes Renger*:455-512. Alter Orient und Altes Testament 267. Münster: Ugarit-Verlag.
- 2000 "Der sogenannte 'geflügelte Tempel' und die 'Himmelfahrt' der Herrscher. Spekulationen über ein ungelöstes Problem der altakkadischen Glyptik und dessen möglichen rituellen Hintergrund," in (ed.) Simonetta Graziani, *Studi sul Vicino Oriente antico dedicati alla memoria di Luigi Cagni*:961-983. Istituto universitario orientale; Dipartimento di studi asiatici, Series minor 61. Napoli: Istituto universitario orientale.
- 2001a "Guter Hirte, Weiser Fürst' - Zur Vorstellung von Macht und zur Macht der Vorstellung im altmesopotamischen Herrschaftsparadigma." *Altorientalische Forschungen*, 28:8-39.
- 2001b "Irano-Sumerica." *Wiener Zeitschrift für die Kunde des Morgenlandes* 91:259-267.
- 2001c "Nur ein Stein," in (eds.) Thomas Richter, Doris Prechel, and Jörg Klinger, *Kulturgeschichten: Altorientalistische Studien für Volkert Haas zum 65. Geburtstag*:383-393. Saarbrücken: SDV Saarbrücker Druckerei und Verlag
- 2001 "Sex, Crime, and Politics. Zur Interpretation sumerischer Literaturwerke. Überlegungen zu Inana-k und Šukaletuda." *Journal of Ancient Civilizations* 16:37-58.
- 2002a "1.2 Die Königslisten als politische Tendenz-Werke?" *Frieburger Universitätsblätter* 156, 2:21-30.
- 2002b "'Babilismus' und die Gottheit <sup>d</sup>Nindagar\*," in (eds.) Oswald Loretz, Kai A. Metzler, and Hanspeter Schaudig, *Ex Mesopotamia et Syria lux : Festschrift für Manfred Dietrich zu seinem 65. Geburtstag*:647-684. Münster: Ugarit Verlag.

Senner, Wayne M., (ed.)

- 1989 "Theories and Myths on the Origins of Writing," in (ed.) Wayne M. Senner, *The Origins of Writing*:1-26. Lincoln, Nebraska: University of Nebraska Press.

Shannon, Claude Elwood, and Warren Weaver

- 1949 [1998] *The Mathematical Theory of Communication*. Urbana: University of Illinois Press.

Shaw, I. M. E.

- 1984 "The Egyptian Archaic Period: A reappraisal of the C-14 dates (1)." *Göttinger Miszellen* 78:79-85.

Sherman, Claire Richter

- 1969 *The Portraits of Charles V of France (1338-1380)*. Monographs on archaeology and fine arts 20. New York: New York University Press for the College Art Association of America.

Shore, Bradd

1996 *Culture in Mind: Cognition, culture, and the problem of meaning*. Oxford: Oxford University Press.

Shors, Tracey J.

1999 "Long-Term Potentiation," in (eds.) Robert A. Wilson and Frank C. Keil, *The MIT Encyclopedia of the Cognitive Sciences*:492-494. A Bradford Book. Cambridge, Massachusetts: MIT Press.

Sievertsen, Uwe

1992 "Das Messer vom Gebel el-Arak." *Mitteilungen des Deutschen Archäologischen Instituts, Abteilung Baghdad* 23:1-75.

Sirevaag, Anita M., and William T. Greenough

1987 "Differential Rearing Effects on Rat Visual Cortex Synapses. III. Neuronal and Glial Nuclei, Boutons, Dendrites, and Capillaries." *Brain Research* 424:320-332.

Sjöberg, Åke

1957-1971 "Götterreisen," in (ed.) Dietz Otto Edzard, *Reallexikon der Assyriologie (Dritter Band)*:480-483. Berlin und New York: Walter de Gruyter.

1976 "Hymns to Ninurta with Prayers for Susin of Ur and Bursin of Larsa," in (ed.) J. W. Hennerdinger Barry Eichler, and Å. Sjöberg, *Samuel Noah Kramer Anniversary Volume: Cuneiform studies in honor of Samuel Noah Kramer*:409-427. Alter Orient und Altes Testament Veröffentlichungen und Geschichte des Alten Orients und des Alten Testaments 25. Kevelaer: Butzon & Bercker.

Smalley, William A., Chia Koua Vang, and Gnia Yee Yang

1990 *Mother of Writing: The origin and development of a Hmong messianic script*. Chicago: University of Chicago Press.

Smith, Brian Cantwell

1998 *On the Origin of Objects*. A Bradford Book. Cambridge, Massachusetts: MIT Press.

Smith, Edward E., and Howard Lasnik, (eds.)

1990 *Thinking. An Invitation to Cognitive Science: Volume 3*. Cambridge, Massachusetts: MIT Press.

Smith, H. S.

1992 "The Making of Egypt: A Review of the influence of Susa and Sumer on Upper Egypt and Lower Nubia in the 4th millennium B.C.," in (eds.) Renée F. Friedman and Barbara Adams, *The Followers of Horus: Studies dedicated to Michael Allen Hoffman 1944-1990*:233-246. Egyptian Studies Association Publication 2. Oxbow Monograph 20. Oxford: Oxbow Books.

Smith, Mary Elizabeth

1973 *Picture Writing from Ancient Southern Mexico: Mixtec place signs and maps*. Norman, Oklahoma: University of Oklahoma Press.

Smith, William Stevenson

- 1949 *A History of Egyptian Sculpture and Painting in the Old Kingdom (Second Edition)*. London: Oxford University Press.  
 1958 *The Art and Architecture of Ancient Egypt*. Harmondsworth, England: Pelican.

Smyth, Padhraic

- 1999 "Hidden Markov Models," in (eds.) Robert A. Wilson and Frank C. Keil, *The MIT Encyclopedia of the Cognitive Sciences*:373-374. A Bradford Book. Cambridge, Massachusetts: MIT Press.

Soden, Wolfram von

- 1965 *Akkdisches Handwörterbuch (Band I: A-L)*. Wiesbaden: Otto Harrassowitz.  
 1972 *Akkdisches Handwörterbuch (Band II: M-S)*. Wiesbaden: Otto Harrassowitz.  
 1981 *Akkdisches Handwörterbuch (Band III: Š-Z)*. Wiesbaden: Otto Harrassowitz.

Soden, Wolfram von, and Wolfgang Röllig

- 1967 *Das Akkadische Syllabar (2. völlig neubearbeitete Auflage)*. Analecta orientalia 42. Roma: Pontificium Institutum Biblicum.  
 1976 *Ergänzungsheft zum Akkadische Syllabar (2. Auflage)*. Analecta orientalia 42A. Roma: Pontificium Institutum Biblicum.

Sollberger, Edmond

- 1955 "Le galet B d'Enanmtumu I<sup>er</sup>." *Orientalia, Nova Series* 24.  
 1956a *Corpus des inscriptions royales présargoniques de Lagaš*. Geneva: E. Droz.  
 1956b "Selected Texts from American Collections." *Journal of Cuneiform Studies* 10:11-31.  
 1957 "Two Early Lagaš Inscriptions in the Iraq Museum." *Sumer* 13:61-64.  
 1957-1971 "Geierstele (historisch)," in (ed.) Dietz Otto Edzard, *Reallexikon der Assyriologie (Dritter Band)*:194-195. Berlin und New York: Walter de Gruyter.  
 1959 "Sumerica." *Zeitschrift für Assyriologie und Vorderasiatische Archäologie* 53.  
 1960 "Notes on the Early Inscriptions From Ur and El-'Obēd." *Iraq* 22:59-68.  
 1969 "The Rulers of Lagaš." *Journal of Cuneiform Studies (Special Volume Honoring Professor Albrecht Goetze)* 21:279-291.

Solso, Robert L.

- 1994 *Cognition and the Visual Arts*. Cambridge, Massachusetts: MIT Press.

Solyman, Toufic

- 1968 *Die Entstehung und Entwicklung der Gotterwaffen im alten Mesopotamien und ihre Bedeutung*. Beirut: H. Abdelnour.

Speiser, E. A.

- 1935 *Excavations at Tepe Gawra: Vol. I*. Philadelphia: University of Pennsylvania Press.  
 1969 "Etana," in (ed.) James B. Pritchard, *Ancient Near Eastern Texts Relating to the Old Testament (Third Edition with Supplement)*:114-119. Princeton: Princeton University Press.

Spelke, Elizabeth S., Karen Breinlinger, Janet Macomber, et. al.

- 1992 "Origins of Knowledge." *Psychological Review* 99, 4:605-632.

Spencer, A. J.

1980 *Catalogue of Egyptian Antiquities in the British Museum (Volume V). Early Dynastic Objects*. London: British Museum Publications for the Trustees of the British Museum.

1993 *Early Egypt: The rise of civilization in the Nile valley*. London. British Museum Press.

Spencer, Jefferey, (ed.)

1996 *Aspects of Early Egypt*. London: British Museum Press.

Sperber, Dan

1975 *Rethinking Symbolism*. Translated by A. L. Morton Cambridge Studies in Social Anthropology. Cambridge: Cambridge University Press.

1985 "Anthropology and Psychology: Towards an epidemiology of representations." *Man* 20, 1:73-89.

1992 "Culture and Matter," in (eds.) Jean-Claude Gardin and Christopher S. Peebles, *Representations in Archaeology*:56-65. Bloomington: Indiana University Press.

1994 "The Modularity of Thought and the Epidemiology of Representations," in (eds.) Lawrence A. Hirschfeld and Susan A. Gelman, *Mapping the Mind: Domain specificity in cognition and culture*:39-67. Cambridge: Cambridge University Press.

Sperber, Dan, and Deirdre Wilson

1995 *Relevance: Communication and cognition*. Oxford: Blackwell.

Spycket, Agnès

1968 *Les statues de culte dans les textes mésopotamiens des origines à la Ire dynaste de Babylone*. Cahiers de la Revue Biblique 9. Paris: Gabalda.

1981 *La statuaire du proche-orient ancien*. Handbuch der Orientalistik. 7. Abt., Kunst und Archäologie ; 1. Bd., Der alte Vordere Orient ; 2. Abschnitt, Die Denkmäler ; B, Vorderasien ; Lfg. 2. Leiden: E. J. Brill.

Steible, Horst

1982a *Die Altsumerischen Bau-und Weihinschriften (Teil 1): Inschriften aus Lagaš*. Freiburger Altorientalische Studien 5. Wiesbaden: Franz Steiner Verlag GmbH.

1982b *Die Altsumerischen Bau-und Weihinschriften (Teil 2): Kommentar zu den Inschriften aus Lagaš Inschriften Ausserhalb von Lagaš*. Freiburger Altorientalische Studien 5. Wiesbaden: Franz Steiner Verlag GmbH.

1989 "Die Beziehungen zwischen Gatumdu und Inanna im Spiegel der Bauinschriften der Lagaš-I- und Lagaš-II-Zeit," in (eds.) Hermann Behrens, Darlene Loding, and Martha T. Roth, *DUMU-E2-DUB-BA-A: Studies in honor of Åke Sjöberg*:507-514. Occasional Publications of the Samuel Noah Kramer Fund 11. Philadelphia: The University Museum.

1991 *Die Neusumerischen Bau-und Weihinschriften (Teil 1): Inschriften der II. Dynastie von Lagaš*. Freiburger Altorientalische Studien 9,1. Wiesbaden: Franz Steiner Verlag GmbH.

Stein, Gil

1999 *Rethinking World-systems: Diasporas, colonies, and interaction in Uruk Mesopotamia*. Tucson: University of Arizona Press.

## Steinkeller, Piotr

- 1980 "Early Dynastic Burial Offerings in the Light of Textual Evidence." A paper delivered at the 190th meeting of the American Oriental Society, San Francisco.
- 1981 "The Renting of Fields in Early Mesopotamia and the Development of the Concept of 'Interest' in Sumerian." *Journal of the Economic and Social History of the Orient* 24, 2:113-145.
- 1984a "Observations on the Function and Use of the Uruk Clay Bullae and Numerical Tablets." A paper delivered at the 194th meeting of the American Oriental Society, Seattle.
- 1984b "Sumerian Miscellanea." *Aula Orientalis* 2.
- 1990 "Threshing Implements in the Ancient Mesopotamia, Cuneiform Sources." *Iraq* 52:19-24.
- 1992 "Mesopotamia in the Third Millennium B.C.," in (ed.) David Noel Freedman, *Anchor Bible Dictionary: Volume 4 (K-N):724-732*. New York: Doubleday.
- 1993 "Early Political Development in Mesopotamia and the Origins of the Sargonic Empire," in (ed.) Mario Liverani, *Akkad. The First World Empire: Structure, ideology, traditions:108-129*. History of the Ancient Near East; Studies 5. Padua: Sargon.
- 1995 "Review of *Zeichenliste der Archaischen Texte aus Uruk* by M. W. Green and Hans J. Nissen." *Bibliotheca Orientalis* 52, 5/6:690-714.
- 1998 "Inanna's Archaic Symbol," in (eds.) Jan Braun, Krystyna Lyczkowska, Maciej Popko, et. al., *Written on Clay and Stone: Ancient Near Eastern studies presented to Krystyna Szarzyńska on the occasion of her 80th Birthday:87-100*. Warsaw: Agade.
- 1999a "On Rulers, Priests and Sacred Marriage: Tracing the evolution of early Sumerian kingship," *Priests and Officials in the Ancient Near East: Papers of the Second Colloquium on the Ancient Near East - The City and its Life held at the Middle Eastern Culture Center in Japan (Mitaka, Tokyo) March 22-24, 1996*. Heidelberg: Universitätsverlag C. Winter.
- 1999b "Review of *Proto-Cuneiform Texts from Diverse Sources* by Roger J. Matthews." *Bulletin of the School of Oriental and African Studies* 62, 1:115-117.
- 2002 "Archaic City Seals and the Question of Early Babylonian Unity," in (ed.) Tzvi Abusch, *Riches Hidden in Secret Places: Ancient Near Eastern studies in memory of Thorkild Jacobsen:249-257*. Winona Lake: Eisenbrauns.
- Unpublished [1994] "Nanshe and the Birds. Paper for the Jacobsen Symposium. London, April 6, 1994." 1-15.
- Unpublished [1995] "Anzu or IM-dugud? (LA colloquium, 1 December 1995)."
- Unpublished [1996] "The Offices of the En and the Ensik: A historical perspective."

## Stève, Marie-Joseph, and Hermanns Gasche

- 1971 *L'acropole de Suse: Nouvelles fouilles (rapport préliminaire)*. Mémoires de la Délégation Archéologique en Iran 46. Paris: Librairie Orientaliste Paul Geuthner.

## Stone, Elizabeth C.

- 1991 "The Spatial Organization of Mesopotamian Cities," in (eds.) Piotr Michalowski, Piotr Steinkeller, Elizabeth Caecilia Stone, et. al., *Velles paraules: Ancient Near Eastern studies in honor of Miguel Civil on the occasion of his sixty-fifth birthday:131-136*. Aula orientalis: Revista de estudios del Próximo Oriente Antiguo 9. Sabadell (Barcelona), Spain: Editorial AUSA.

Strathern, Marilyn

1999 "Social Relations and the Idea of Externality," in (eds.) Colin Renfrew and Chris Scarre, *Cognition and Material Culture: The archaeology of symbolic storage*:135-148. McDonald Institute Monographs. Cambridge: McDonald Institute for Archaeological Research.

Streck, M. P.

1998-2001 "Ninurta/Ningirsu. A. I. In Mesopotamien," in (ed.) D. O. Edzard, *Reallexikon der Assyriologie (Neunter Band)*:512-522. Berlin: Walter de Gruyter.

Strommenger, Eva

1960 "Das Menschenbild in der altmesopotamischen Rundplastik von Mesilim bis Hammurapi." *Baghdader Mitteilungen* 1:1-103.

1964 *The Art of Mesopotamia*. London: Thames and Hudson.

1973 "Kunststeinfragmente aus dem 'Riemchengebäude' in Warka." *Baghdader Mitteilungen* 6:19-27.

1980a "The Chronological Division of the Archaic Levels of Uruk-Eanna VI-III/II: Past and present." *American Journal of Archaeology* 84:479-487.

1980b *Habuba Kabira: Eine Stadt vor 5000 Jahren. Ausgrabungen der Deutschen Orient-Gesellschaft am Euphrat in Habuba Kabira, Syrien*. Sendschrift der Deutschen Orient-Gesellschaft 12. Mainz am Rhein: Philipp von Zabern.

Stuart-Hamilton, Ian

1996 (rev. ed) *Dictionary of Cognitive Psychology*. London and Bristol, Pennsylvania: Jessica Kinksley Publishers.

Sürenhagen, Dietrich

1986 "The Dry Farming Belt: The Uruk period and subsequent developments," in (ed.) Harvey Weiss, *The Origins of Cities in Dry-Farming Syria and Mesopotamia in the Third Millennium B.C.*:7-44. Guilford, Connecticut: Four Quarters.

1999 *Untersuchungen zur relativen Chronologie Babyloniens und angrenzender Gebiete von der ausgehenden Ubaidzeit bis zum Beginn der frühdynastisch II-Zeit*. Heidelberger Studien zum alten Orient 8. Heidelberg: Heidelberger Orientverlag.

Szarzyńska, Krystyna

1987 "The Sumerian Goddess INANA-KUR," in (eds.) Marek Mejer, Maciej Popko, and Bogdan Skladanek, *Papers on Asia Past and Present*:7-14. Orientalia Varsovienska 1. Warsaw: Wdawnictwa Uniwersytetu Warszawskiego.

1987-1988 "Some of the Oldest Cult Symbols in Archaic Uruk." *Jaarbericht van het Voorasiatisch-Egyptisch Genootschap Ex Oriente Lux* 30:1-21.

1992a "Names of Temples in the Archaic Texts from Uruk." *Acta Sumerologica* 14:269-287.

1992b "Some Comments on Individual Entries in the Uruk Sign-List ZATU. Review of *Zeichenliste der Archaischen Texte aus Uruk* by M. W. Green and Hans J. Nissen." *Acta Sumerologica* 18:235-242.

1993 "Archaic Sumerian Signs Indicating Successive Days," in (eds.) Julia Zablocka and Stefan Zawadzki, *Sulmu IV. Everyday Life in Ancient Near East: Papers presented at the international conference, Poznan, 19-22 September, 1989*:273-285. Seria Historia / Uniwersytet im. Adama Mickiewicza w Poznaniu 182. Poznan: Uam.

1994 "Archaic Sumerian Tags." *Journal of Cuneiform Studies* 46:1-10.

1996 "Archaic Sumerian Standards." *Journal of Cuneiform Studies* 48:1-15.

- 1997a *Sumerica: Prace sumeroznawcze*. *Philologia orientalis* 3. Warszawa: Dialog.
- 1997b "Cult of the Goddess Inana in Archaic Uruk," *Sumerica: Prace sumeroznawcze*:141-153. *Philologia orientalis* 3. Warszawa: Dialog.
- Tallon, Françoise, (ed.)  
 1995 *Les pierres précieuses de l'Orient ancien: Des sumériens aux sassanides*, Les doissiers du musée du Louvre. Exposition-dossier du département des Antiquités orientales 49. Paris: Editions de la Réunion ds musées nationaux.
- Talmy, Leonard  
 1988 "Force Dynamics in Language and Cognition." *Cognitive Science* 12:49-100.
- Taylor, John R.  
 1995 (2nd ed.) *Linguistic Categorization: Prototypes in linguistic theory*. Oxford: Clarendon Press.
- Teissier, Beatrice  
 1987 "Glyptic Evidence for a Connection Between Iran, Syro-Palestine and Egypt in the Fourth and Third Millenia." *Iran* 25:27-53.
- Thesiger, Wilfred  
 1954 "The Marshmen of Southern Iraq." *The Geographical Journal* 120.  
 1964 *The Marsh Arabs*. London: Longmans, Green and Co.
- Thompson, R. Campbell, and R. W. Hamilton  
 1932 "The British Museum Excavations on the Temple of Ishtar at Nineveh 1930-31." *Annals of Archaeology and Anthropology* 19:55-116.
- Thompson, R. Campbell, and Sir Max E. L. Mallowan  
 1933 "The British Museum Excavations at Nineveh 1931-32." *Annals of Archaeology and Anthropology* 20:71-186.
- Thomsen, Marie-Louise  
 1984 *The Sumerian Language: An introduction to its history and grammatical structure*. Mesopotamia: Copenhagen Studies in Assyriology 10. Copenhagen: Akademisk Forlag.
- Thureau-Dangin, François  
 1897a "Un cadastre chaldéen." *Revue d'assyriologie et d'archéologie orientale* 4, 1:13-27.  
 1897b "La cône historique d'Entemena." *Revue d'assyriologie et d'archéologie orientale* 4, 2:37-50.  
 1897c "La forme d'un traite entre Shirpourla et Gishban." *Revue d'assyriologie et d'archéologie orientale* 4, 4:123-125.  
 1904a "La ruine de Shirpourla (Lagash) sous la règne d'Ourou-Kagina." *Revue d'assyriologie et d'archéologie orientale* 6, 1:28-32.  
 1904b "Nouvelle inscriptions de Goudéa." *Revue d'assyriologie et d'archéologie orientale* 6, 1:23-25.  
 1904c "Un nouveau roi d'Our." *Revue d'assyriologie et d'archéologie orientale* 6, 1:69-71.

- 1904d "Replique de l'inscription d'Arad-Nannar." *Revue d'assyriologie et d'archéologie orientale* 6, 1:67-68.
- 1905a *Les Inscriptions de Sumer et d'Akkad: Transcription et traduction*. Paris: Ernst Leroux.
- 1905b *Les cylindres de Goudéa: Transcription, traduction, commentaire, grammaire, et lexique. Premier partie: Transcription et traduction*. Paris: Leroux.
- 1907 *Die Sumerischen und Akkadischen Königsinschriften*. Vorderasiatische Bibliothek. I. Band, Abteilung 1. Leipzig: J.C. Hinrichs'sche Buchhandlung.
- 1912a "Notes Assyriologiques." *Revue d'assyriologie et d'archéologie orientale* 9, 2:73-79.
- 1912b "Sceaux de Tello et sceaux de Harappa." *Revue d'assyriologie et d'archéologie orientale* 22, 3:99-101.
- 1925 *Les cylindres de Goudéa découverts par Ernest de Sarzec a Tello*. Musée du Louvre, Département des Antiquités Orientales. Textes cunéiformes 8. Paris: Paul Geuthner.
- Tobler, A. J.  
1950 *Excavations at Tepe Gawra. Volume II: Levels IX - XX*. Philadelphia: University of Pennsylvania.
- Todorov, Tzvetan  
1984 *Mikhail Bakhtin: The dialogical principle*. Theory and History of Literature 13. (ed.) Wlad Godzich. Minneapolis: University of Minnesota Press.
- Tompkins, Jane P., (ed.)  
1980 *Reader-Response Criticism: From formalism to post-structuralism*. Baltimore: Johns Hopkins University Press.
- Tooby, John, and Leda Cosmides  
1992 "The Psychological Foundations of Culture," in (eds.) Jerome H. Barkow, Leda Cosmides, and John Tooby, *The Adapted Mind: Evolutionary psychology and the generation of culture*:19-136. Oxford: Oxford University Press.
- Trigger, Bruce G., Barry J. Kemp, David O'Connor, et. al.  
1983 *Ancient Egypt: A social history*. Cambridge: Cambridge University Press.
- Tufnell, O.  
1958 *Lachish IV: The bronze age*. The Wellcome-Marston Archeological Research Expedition to the Near East, IV. London: The Trustees of the Late Sir Henry Wellcome; Oxford University Press.
- Turner, Mark  
2001 *Cognitive Dimensions of Social Science*. Oxford: Oxford University Press.
- Uexküll, Jacob von  
1926 [1920] *Theoretical Biology*. Translated by D. L. Mackinnon International Library of Psychology Philosophy and Scientific Method. New York: Harcourt, Brace, & Company.  
1982 "The Theory of Meaning." *Semiotica* 41, 1:1-87.  
1992 [1934] "A Stroll Through the Woods of Animals and Men: A picture book of invisible worlds." *Semiotica* 89, 4:319-391.

Unger, Eckhard

- 1926 *Sumerische und Akkadische Kunst*. Breslau: Ferdinand Hirt.  
 1932 "Der Obelisk des Königs Assurnasirpal I. aus Ninive." *Mitteilungen der Altorientalischen Gesellschaft, Leipzig* 6:1-2.

Unknown (ed.)

- 1909 *Hilprecht anniversary volume: Studies in Assyriology and archaeology dedicated to Hermann V. Hilprecht upon the twenty-fifth anniversary of his doctorate and his fiftieth birthday (July 28)*. Leipzig: Hinrichs.

Urban, Gregg

- 1992 "Semiotics: Semiotics and anthropological linguistics," in (ed.) William Bright, *International Encyclopedia of Linguistics*:406-407. New York: Oxford.

Vallat, François

- 1986 "The Most Ancient Scripts of Iran: The current situation." *World Archaeology* 17, 3:335-347.

Vandersleyen, Claude

- 1975 *Das alten Ägypten*. Propyläen Kunstgeschichte 17. Berlin: Propyläen Verlag.

Vandier, Jacques

- 1952a *Manuel d'archéologie égyptienne: I. Les époques de formation (première partie): La préhistoire*. Paris: J. Picard.  
 1952b *Manuel d'archéologie égyptienne: I. Les époques de formation (deuxième partie): Les trois premières dynasties*. Paris: J. Picard.

Vanstiphout, Hermann L. J.

- 1997 "Why did Enki Organize the World?," in (eds.) I. L. Finkel and M. J. Geller, *Sumerian Gods and Their Representations*:117-135. Cuneiform Monographs 7. Groningen: Styx.

Varela, Francisco J., Evan Thompson, and Eleanor Rosch

- 1993 *The Embodied Mind: Cognitive science and human experience*. Cambridge, Massachusetts: MIT Press.

Various, Unknown, (eds.)

- 1935 *Miscellanea orientalia: Dedicata Antonio Deimel, annos LXX complenti, Analecta orientalia; commentationes scientificae de rebus Orientis antiqui* 12. Roma: Pontificio Istituto Biblico.

Veenhof, Klaus R.

- 1994 "Review of *Cities, Seals and Writing. Archaic Seal Impressions from Jemdet Nasr* by Roger J. Matthews." *Journal of the Economic and Social History of the Orient* 37:186-189.  
 1996 *Houses and Households in Ancient Mesopotamia: Papers read at the 40e Rencontre Assyriologique Internationale, Leiden, July 5-8, 1993*. Leiden: Nederlands Instituut.

Vertesalji, Peter Paul

1988 "Das Ende der Uruk-Zeit im Lichte der Grabungsergebnisse der sogenannten 'archaischen' Siedlung bei Uruk-Warka." *Acta Prehistorica et Archeologica* 20:9-26.

1992 "Le manche de couteau de Gebel el-'Arak dans le contexte des relations entre le Mésopotamie et l'Égypte," in (eds.) Dominique Charpin and M. Francis Joannès, *La circulation des biens, des personnes et des idées dans le Proche-orient ancien: Actes de la XXXVIIIe Rencontre Internationale (Paris, 8-10 juillet 1991):29-43*. Paris: Editions Recherche sur les Civilisations.

Vigneau, André

1936 *Encyclopédie photographique de l'art: Le Musée du Louvre (Vol. 1)*. Paris: Editions 'TEL'.

Vigneau, André, and Etienne Drioton

1949 *Encyclopédie photographique de l'art: Le Musée du Caire*. Paris: Editions 'TEL'.

Vito, Robert A. di

1993 *Studies in Third Millennium Sumerian and Akkadian Personal Names: The designation and conception of the personal god*. Studia Pohl: Series Maior 16. Rome: Editrice Pontificio Instituto Biblico.

Voigt, Mary M.

1987 "Relative and Absolute Chronologies for Iran Between 6.000 and 3.500 cal. BC," in (eds.) Oliver Aurenche, Jacques Evin, and Francis Hours, *Chronologies du Proche Orient. Chronologies in the Near East: Relative chronologies and absolute chronology 16,000 - 4,000 B.P. C.N.R.S. International Symposium Lyon (France) 24-28 November 1986 (part i):615-646*. Maison de l'Orient Méditerranéen (C.N.R.S. Université Lumière - Lyon 2), Lyon, France. Archaeological Series 3; British Archaeological Reports: International Series 379 (i). Oxford: British Archaeological Reports.

Vološinov, V. N.

1993 *Marxism and the Philosophy of Language*. (ed.) Ladislav Matejka and I. R. translated by Titunic. Cambridge, Massachusetts: Harvard University Press.

Vosniadou, Stella, and Andrew Ortony, (eds.)

1989 *Similarity and Analogical Reasoning*. Cambridge: Cambridge University Press.

Vygotsky, Lev

1978 *Mind in Society: The development of higher psychological processes*. Cambridge, Massachusetts: Harvard University Press.

1994 *Thought and Language*. Translated by Alex Kozulin. Cambridge, Massachusetts: MIT Press.

Walker, Christopher, and Michael Brennan Dick

1999 "The Induction of the Cult Image in Mesopotamia: The Mesopotamian *mis pi* ritual," in (ed.) Michael Brennan Dick, *Born in Heaven, Made on Earth: The making of the cult image in the ancient Near East:55-122*. Winona Lake: Eisenbrauns.

Walker, C. B. F.

1990 "Cuneiform," in (ed.) J. T. Hooker, *Reading the Past: Ancient writing from cuneiform to the alphabet*:15-74. Berkeley: University of California Press.

Ward, William

1910 *The Seal Cylinders of Western Asia*. Carnegie Institution of Washington 100. Washington D. C.: Carnegie Institution.

Watanabe, Kazuko, (ed.)

1999 *Priests and Officials in the Ancient Near East: Papers of the Second Colloquium on the Ancient Near East - The City and its Life held at the Middle Eastern Culture Center in Japan (Mitaka, Tokyo) March 22-24, 1996*. Heidelberg: Universitätsverlag C. Winter.

Watelin, Louis Charles, and Stephen Langdon

1934 *Excavations at Kish, IV: 1925-30*. Paris: Geuthner.

Way, Thomas von der

1986 "Tell el Fara 'in Buto, 1. Bericht." *Mitteilungen des Deutschen Archäologischen Instituts, Abteilung Kairo* 42:191-212.

1987 "Tell el Fara 'in Buto, 2. Bericht." *Mitteilungen des Deutschen Archäologischen Instituts, Abteilung Kairo* 43:241-257.

1988a "Investigations Concerning the Early Periods in the Northern Delta of Egypt," in (ed.) Edwin C. M. van den Brink, *The Archaeology of the Nile Delta, Egypt: Problems and priorities. Proceedings of the Seminar held in Cairo, 19 - 22 October 1986, on the Occasion of the Fifteenth Anniversary of the Netherlands Institute of Archaeology and Arabic Studies in Cairo*:245-249. Amsterdam: Netherlands Foundation for Archaeological Research in Egypt.

1988b "Tell el Fara 'in Buto, 3. Bericht." *Mitteilungen des Deutschen Archäologischen Instituts, Abteilung Kairo* 44:283-306.

1989 "Tell el Fara 'in Buto, 4. Bericht." *Mitteilungen des Deutschen Archäologischen Instituts, Abteilung Kairo* 45:275-307.

1992a "Indications of Architecture with Niches at Buto," in (eds.) Renée F. Friedman and Barbara Adams, *The Followers of Horus: Studies dedicated to Michael Allen Hoffman 1944-1990*:217-226. Egyptian Studies Association Publication 2. Oxbow Monograph 20. Oxford: Oxbow Books.

1992b "Excavations at Tell El-Fara'in / Buto in 1987-1989," in (ed.) Edwin C. M. van den Brink, *The Nile Delta in Transition: 4th - 3rd Millennium B.C.. Proceedings of a Seminar Held in Cairo, 21. - 24 October 1990, at the Netherlands Institute of Archaeology and Arabic Studies*:1-10. Tel Aviv: Distributed by the Israel Exploration Society for Edwin C. M. van den Brink.

Way, Thomas von der, and Joachim Boessneck

1997 *Tell el-Fara 'in, Buto I: Ergebnisse zum frühen Kontext Kampagnen der Jahre 1983-1989*. Archäologische Veröffentlichungen / Deutsches Archäologisches Institut. Abteilung Kairo 83. Mainz am Rhein: Philipp von Zabern.

Weadock, Penelope N.

1958 *The Giparu at Ur: A study of the archaeological remains and related material*. Ph.D. dissertation, University of Chicago Press.

Weber, Otto

1914-1915 "Ein altbabylonisches Steinrelief." *Amtliche Berichte aus den Königlichen Kunstsammlungen* 36, 4:114-115.

Weeks, Kent R.

1971-1972 "Preliminary Report on the First Two Seasons at Hierakonpolis: Part II. The Early Dynastic Palace." *Journal of the American Research Center in Egypt* 9:29-33.  
1985 *A Historical Bibliography of Egyptian Prehistory*. Winona: Eisenbrauns.

Weinstein, James

1971-1972 "A Foundation Tablet From Hierakonpolis." *Journal of the American Research Center in Egypt* 9:133-135.  
1980 "Palestinian Radiocarbon Dating: A reply to James Mellaart." *Antiquity* 54:21-28.

Weiss, Harvey, (ed.)

1986 *The Origins of Cities in Dry-Farming Syria and Mesopotamia in the Third Millennium B.C.* Guilford, Connecticut: Four Quarters.

Weissbach, F. H.

1938 "Dudu," in (ed.) Erich and Bruno Meissner Ebling, *Reallexikon der Assyriologie (Zweiter Band)*:237. Berlin und New York: Walter de Gruyter.

Wendorf, Fred, and Romuald Schild

1980 *Prehistory of the Eastern Sahara*. Studies in Archaeology. New York: Academic Press.

Wenke, Robert J.

1989 "Egypt: Origins of complex societies." *Annual Review of Anthropology* 18:128-155.  
1991 "The Evolution of Early Egyptian Civilization: Issues and evidence." *Journal of World Prehistory* 5:279-329.

White, Hayden

1981 "The Value of Narrativity in the Representation of Reality," in (ed.) W. J. T. Mitchell, *On Narrative*:1-24. Chicago: University of Chicago Press.  
1987 *The Content of the Form: Narrative discourse an historical representation*. Baltimore: Johns Hopkins Press.

White, Randall

1989 "Production, Complexity and Standardization in Early Aurignacian Bead and Pendant Manufacture Evolutionary Implications," in (eds.) Paul Mellars and Chris Stringer, *The Human Revolution: Behavioral and biological perspectives on the origins of modern humans*:366-390. Edinburgh: Edinburgh University Press.  
1993 "Technological and Social Dimensions of Aurignacian Age Body Ornaments Across Europe," in (eds.) Heidi Knecht, Anne Pike-Tay, and Randall White, *Before Lascaux: The complex record of the early Upper Paleolithic*:247-295. Boca Raton: CRC Press.

Whitehouse, Helen

1987 "King Den in Oxford." *Oxford Journal of Archaeology* 6:257-267.

- Whiten, Andrew, and Richard W. Byrne  
 1988 "The Machiavellian Intelligence Hypothesis: Editorial," in (eds.) Richard W. Byrne and Andrew Whiten, *Machiavellian Intelligence: Social expertise and the evolution of intellect in monkeys, apes, and humans*:1-9. Oxford: Clarendon Press.  
 1997 *Machiavellian Intelligence II: Extensions and evaluations*. Cambridge: Cambridge University Press.
- Whorf, Benjamin  
 1956 *Language, Thought, Reality: Selected writings of Benjamin Lee Whorf*. Cambridge: M.I.T. Press.
- Wickede, Alwo von  
 1990 *Prähistorische Stempelglyptik in Vorderasien*. Münchener Universitäts-Schriften: Philosophische Fakultät 12/ Münchener vorderasiatische Studien 6. München: Profil Verlag.
- Wiener, Norbert  
 1954 *The Human Use of Human Beings: Cybernetics and society (2nd rev.ed.)*. London: Eyere and Spottiswoode.
- Wierzbicka, Anna  
 1996 *Semantics: Primes and universals*. Oxford: Oxford University Press.
- Wiggermann, F. A. M.  
 1981-1982 "Exit Talim!: Studies in Babylonian demonology." *Jaarbericht van het Voor-Asiatisch-Egyptisch Gezelschap Ex Oriente Lux* 27:90-105.  
 1992 *Mesopotamian Protective Spirits: The ritual texts*. Cuneiform Monographs 1. Groningen: Styx.
- Wilcke, Claus  
 1969 *Das Lugalbandaepos*. Wiesbaden: Harrassowitz.  
 1989 "Genealogical and Geographical Thought in the Sumerian King List," in (eds.) Hermann Behrens, Darlene Loding, and Martha T. Roth, *DUMU-E2-DUB-BA-A: Studies in honor of Åke Sjöberg*:557-572. Occasional Publications of the Samuel Noah Kramer Fund 11. Philadelphia: The University Museum.  
 1991 "Schrift und Literatur," in (ed.) Barthel Hrouda, *Der alte Orient: Geschichte und Kultur des alten Vorderasien*:271-298. Munich: C. Bertelsmann.  
 1995 "Die Inschrift der "Figure aux plumes"—ein frühes Werke sumerischer Dichtkunst," in (eds.) Uwe Finkbeiner, Reinhard Dittmann, and Harald Hauptmann, *Beiträge zur Kulturgeschichte Vorderasiens: Festschrift für Rainer Michael Boehmer*:669-674. Mainz am Rhein: Verlag Philipp von Zabern.
- Wilkinson, Richard H.  
 1992 *Reading Egyptian Art: A Hieroglyphic guide to ancient Egyptian painting and sculpture*. London: Thames and Hudson.
- Wilkinson, Toby A. H.  
 1996 *State Formation in Egypt: Chronology and society*. BAR International Series 651. Cambridge Monographs in African Archaeology 40. Oxford: British Archaeological Reports.

Williams, Bruce B.

1986 *Excavations Between Abu Simbel and the Sudan Frontier, Part 1: The A-Group Royal cemetery at Qustul, Cemetery L.* Oriental Institute Nubian Expedition 3. Chicago: Oriental Institute.

1988 "Narmer and the Coptos Colossi." *Journal of the American Research Center in Egypt* 25:35-59.

1992 "Egypt: History of (Neolithic to Dynasty 1)," in (ed.) David Noel Freedman, *Anchor Bible Dictionary: Volume 2 (D-G)*:236-242. New York: Doubleday.

Williams, Bruce B., and Thomas J. Logan

1987 "The Metropolitan Museum Knife Handle and Aspects of Pharonic Imagery Before Narmer." *Journal of Near Eastern Studies* 46, 4:245-384.

Willis, Roy

1994 *Signifying Animals: Human meaning in the natural world.* One World Archaeology 16. London: Routledge & Kegan Paul.

Wilson, Robert A., and Frank C. Keil, (eds.)

1999 *The MIT Encyclopedia of the Cognitive Sciences*, A Bradford Book. Cambridge, Massachusetts: MIT Press.

Winter, Irene J.

1981 "Royal Rhetoric and the Development of Historical Narrative in Neo-Assyrian Reliefs." *Studies in Visual Communication* 7, 2:2-38.

1983 "The Program of the Throneroom of Assurnasirpal II," in (eds.) Prudence O. Harper and Holly Pittman, *Essays on Near Eastern Art and Archaeology in Honor of Charles Kyrle Wilkinson*:15-32. New York: The Metropolitan Museum of Art.

1984 "Review of *La statuaire du proche-orient ancien* by A. Spycket." *Journal of Cuneiform Studies* 36, 1:102-114.

1986a "After the Battle is Over: 'The Stele of the Vultures' and the beginning of historical narrative in the art of the ancient Near East." *Studies in the History of Art* 16:11-35.

1986b "Eannatum and the 'King of Kish'? - Another look at the Stele of the Vultures and 'cartouches' in early Sumerian art." *Zeitschrift für Assyriologie und Vorderasiatische Archäologie* 76:205-212.

1989 "The Body of the Able Ruler: Toward an Understanding of the Statues of Gudea," in (eds.) Hermann Behrens, Darlene Loding, and Martha T. Roth, *DUMU-E2-DUB-BA-A: Studies in honor of Åke Sjöberg*:573-584. Occasional Publications of the Samuel Noah Kramer Fund 11. Philadelphia: The University Museum.

1992 "Idols of the King: Royal images as recipients of ritual action in ancient Mesopotamia." *Journal of Ritual Studies* 6:13-42.

1995 "Aesthetics in Ancient Mesopotamian Art," in (ed.) Jack M. Sasson, *Civilizations of the Ancient Near East IV*:2570-2580. New York: Scribner's.

Wiseman, D. J.

1959 *Catalogue of the Western Asiatic Seals in the British Museum. Cylinder Seals I: Uruk-Early Dynastic periods.* London: Trustees of the British Museum.

Witkowski, Stanley R., and Cecil H. Brown

1975 "Lexical Universals." *Annual Review of Anthropology* 7:427-451.

- 1977 "An Explanation of Color Nomenclature Universals." *American Anthropologist* 79:50-57.
- Wittkower, Rudolf  
1938-1939 "Eagle and Serpent: A Study in the migration of symbols." *Journal of the Warburg Institute* 2:293-325.
- Witzel, P. Maurus  
1931-1941 "Die Diorite-Platte Ur-Ninas (und das Rohrhaus in Gilgames-Epos)." *Archiv für Orientforschung* 7:33-36.
- Woolley, Sir C. Leonard  
1932 "Excavations at Ur, 1931-2." *The Antiquaries Journal* 12, 4:355-392.  
1934 *The Royal Cemetery* (2 Vols.). Publications of the Joint Expedition of the British Museum and the Museum of the University of Pennsylvania to Mesopotamia. Ur Excavations 2. (ed.) E. R. Burrows, Arthur Keith, L. Legrain, *et. al.* Philadelphia and London: The Trustees of the Two Museums.  
1956 *The Early Periods*. Publications of the Joint Expedition of the British Museum and the Museum of the University of Pennsylvania to Mesopotamia. Ur Excavations 4. Philadelphia and London: The Trustees of the Two Museums.  
1974 *The Buildings of the Third Dynasty*. Publications of the Joint Expedition of the British Museum and the Museum of the University of Pennsylvania to Mesopotamia. Ur Excavations 6. Philadelphia and London: The Trustees of the Two Museums.
- Wright, Gary A.  
1969 *Obsidian Analyses and Prehistoric Near Eastern Trade: 7500-3500 B.C.* Museum of Anthropology, University of Michigan. Ann Arbor: The University of Michigan.
- Wynn, Thomas  
2000 "Symmetry and the Evolution of the Modular Linguistic Mind," in (eds.) Peter Carruthers and Andrew Chamberlain, *Evolution and the Human Mind: Modularity, language and meta-cognition*:113-139. Cambridge: Cambridge University Press.
- Yates, Frances A.  
1992 *The Art of Memory*. Pimlico: London.
- Zairns, Juris  
1989 "Ancient Egypt and the Red Sea Trade: The case for obsidian in the Predynastic and Archaic periods," in (eds.) Albert Leonard Jr. and Bruce B. Williams, *Essays in Ancient Civilization Presented to Helene J. Kantor*:339-369. Studies in Ancient Oriental Civilizations 47. Chicago: University of Chicago Press.
- Zervos, Christian  
1935 *L'art de la Mésopotamie de la fin du quatrième millénaire au XVe siècle avant notre ère*. Paris: Cahiers d'Art.
- Zettler, Richard L.  
1987 "Seals as Artifacts of Institutional Administration in Ancient Mesopotamia." *Journal of Cuneiform Studies* 39:197-240.

1989 "Pottery Profiles Reconstructed from Jar Sealings in the Lower Seal Impression Strata (SIS 8-4) at Ur: New Evidence for Dating," in (eds.) Albert Leonard Jr. and Bruce B. Williams, *Essays in Ancient Civilization Presented to Helene J. Kantor*:369-387.

Studies in Ancient Oriental Civilizations 47. Chicago: University of Chicago Press.

1991 "Administration of the Temple of Inanna at Nippur under the Third Dynasty of Ur: Archaeological and documentary evidence," in (eds.) McGuire Gibson and Robert D. Biggs, *The Organization of Power: Aspects of bureaucracy in the ancient Near East (2nd ed.)*:101-114. Studies in Ancient Oriental Civilizations 46. Chicago: University of Chicago Press.

1992 *The Ur III Temple of Inanna at Nippur*. Berliner Beiträge zum Vordern Orient 11. Berlin: Dietrich Reimer Verlag.

Zettler, Richard L., and Lee Horne, (eds.)

1998 *Treasures from the Royal Tombs of Ur*. Philadelphia: University of Pennsylvania Museum of Archaeology and Anthropology.

Zimansky, Paul

1993 "Review of *Before Writing* by Denise Schmandt-Besserat." *Journal of Field Archaeology* 20:513-517.

Zubrow, Ezra B. W., and Patrick T. Daly

1999 "Symbolic Behaviour: The origin of a spatial perspective," in (eds.) Colin Renfrew and Chris Scarre, *Cognition and Material Culture: The archaeology of symbolic storage*:157-176. McDonald Institute Monographs. Cambridge: McDonald Institute for Archaeological Research.

Zurif, Edgar B.

1990 "Language and the Brain," in (eds.) Daniel N. Osherson and Howard Lasnik, *Language. An Invitation to Cognitive Science: Volume 1*:177-198. Cambridge, Massachusetts: MIT Press.

<b>Catalog #:</b>	1	<b>Plate #:</b>	64
<b>Object Type:</b>	Relief: Plaque		
<b>Collection:</b>	Musée du Louvre	<b>Collection #:</b>	AO 2344
<b>Period:</b>	Early Dynastic IIIA	<b>Height x Width (centimeters):</b>	40 x 47
<b>Ruler:</b>	Urnanše		
<b>Provenance:</b>	Excavation	<b>Material:</b>	Limestone
<b>Site:</b>	Telloh (Girsu)	<b>Excavator:</b>	de Sarzec
<b>Find number:</b>			
<b>Area:</b>	Tell K - Area and level of the "Construction d' Urnanše" ("Maison des fruits")		
<b>Remarks:</b>	Found on the pavement outside the main structure		

**Bibliography:**

Amiet 1980a:Fig. 324, Pl. 44  
Barton 1929:18 (9)  
Boese 1971:197-198 (T 4), Pl. 39 (1)  
Braun-Holzinger 1991:308 (W 1)  
Caubet and Bernus-Taylor 1991:25 (bottom)  
Christian 1940:Pl. 276 (1)  
Conteneau n.d.:Pl. 3  
Conteneau 1927:4576-478, Fig. 348  
Cooper 1986:22-23 (La 1.2)  
Hansen 1975:118, Pl. 85  
Heuzey 1897:103, Fig. 8  
Heuzey 1902:96-100, Fig. 8  
Moortgat 1969:Pl. 109  
Parrot 1948:90-91, pl. 5a  
Pelzel 1974:No. 78  
de Sarzec and Heuzey 1884-1912:Pl. 21bis (1), part . ép. 37  
Sollberger 1956a:2 (Urn. 20)  
Sollberger and Kupper 1971:44-45 (IC3c)  
Steible 1982a:82-84 (Urn. 20)  
Strommenger 1964:Pl. 73  
Thureau-Dangin 1907:8-9 (m)  
Vigneau 1936 (Vol. 1):Pl. 181  
Zervos 1935:83

<b>Catalog #:</b>	2	<b>Plate #:</b>	66
<b>Object Type:</b>	Relief: Plaque		
<b>Collection:</b>	Musée du Louvre	<b>Collection #:</b>	AO 2345
<b>Period:</b>	Early Dynastic IIIA	<b>Height x Width (centimeters):</b>	23 x 30
<b>Ruler:</b>	Urnanše		
<b>Provenance:</b>	Excavation	<b>Material:</b>	Limestone
<b>Site:</b>	Telloh (Girsu)	<b>Excavator:</b>	de Sarzec
<b>Find number:</b>			
<b>Area:</b>	Tell K - Area and level of the "Construction d' Urnanše" ("Maison des fruits")		
<b>Remarks:</b>	Found on the pavement outside the main structure		

**Bibliography:**

Amiet 1980a:Fig. 326  
 Barton 1929:18 (10)  
 Boese 1971:18-19 (T 6), Pl. 30 (1)  
 Braun-Holzinger 1991:308 (W 2)  
 Cooper 1986:23 (La 1.3)  
 Heuzey 1902:100-101  
 Moortgat 1969:Pl. 112  
 Parrot 1948:92, Pl. 5b  
 Pelzel 1974:No. 81  
 de Sarzec and Heuzey 1884-1912:171, Pl. 2bis (2)  
 Sollberger 1956a:2 (Urn. 21)  
 Steible 1985a:84-84 (Urn. 21)  
 Thureau-Dangin 1907:8-9 (n)  
 Unger 1926:74, Fig. 6  
 Zervos 1935:82

<b>Catalog #:</b>	3	<b>Plate #:</b>	196
<b>Object Type:</b>	Relief: Plaque		
<b>Collection:</b>	Musée du Louvre	<b>Collection #:</b>	AO 3290
<b>Period:</b>	Early Dynastic IIIA or IIIB	<b>Height x Width (centimeters):</b>	17 x 25
<b>Ruler:</b>			
<b>Provenance:</b>	Excavation	<b>Material:</b>	Calcite
<b>Site:</b>	Telloh (Girsu)	<b>Excavator:</b>	de Sarzec
<b>Find number:</b>			
<b>Area:</b>	Tell V - Area of the "Tell des tablettes"		
<b>Remarks:</b>			

**Bibliography:** Boese 1971:200 (T 9), Pl. 30 (4)  
Conteneau 1934:Pl. 4b  
Christian 1940:Pl. 278, Fig. 2  
Heuzey 1902:365-366  
Parrot 1948:90, Fig. 22d, Pl. 7b  
Pelzel 1974:No. 86  
de Sarzec and Heuzey 1884-1906:Pl. 6ter 4

**Catalog #:** 4 **Plate #:** 172

**Object Type:** Relief: Plaque

**Collection:** Musée du Louvre **Collection #:** AO 2783

**Period:** Early Dynastic IIIA **Height x Width (centimeters):** 15 x 21

**Ruler:** Urnanše

**Provenance:** Art market **Material:** Alabaster

**Site:** Telloh (Girsu) **Excavator:** Clandestine/Unknown

**Find number:**

**Area:**

**Remarks:** Purchased in Baghdad in 1899

**Bibliography:** Boese 1971:196-197 (T 1), Pl. 28 (1)  
Braun-Holzinger 1991:309 (W 5)  
Christian 1940:Pl. 276 (2)  
Conteneau 1927:459, Fig. 350  
Conteneau 1934:8-9, Pl. 4a  
Cooper 1986:31 (La 1.26)  
Heuzey 1902:92-95, Fig. 7  
Parrot 1948:87  
Pelzel 1974:No. 75  
Sollberger 1956a:7 (Urn. 41)  
Steible 1982a:106 (Urn. 41)

<b>Catalog #:</b>	5	<b>Plate #:</b>	173
<b>Object Type:</b>	Relief: Plaque		
<b>Collection:</b>	Musée du Louvre	<b>Collection #:</b>	AO 49
<b>Period:</b>	Early Dynastic IIIA	<b>Height x Width (centimeters):</b>	16 x 12
<b>Ruler:</b>	Urnanše		
<b>Provenance:</b>	Excavation	<b>Material:</b>	Limestone
<b>Site:</b>	Telloh (Girsu)	<b>Excavator:</b>	de Sarzec
<b>Find number:</b>			
<b>Area:</b>	Tell A - Area of the "Tell du palais"		
<b>Remarks:</b>			

**Bibliography:** Babelon 1888:34-35, Fig. 10  
Boese 1971:197 (T 2), Pl. 28 (2)  
Braun-Holzinger 1991:309-310 (W 6)  
Christian 1940:Pl. 276 (3)  
Cooper 1986:31 (La 1.26)  
Heuzey 1902:91-92  
Parrot 1948:87, Fig. 22c  
Pelzel 1974:No. 77  
de Sarzec and Heuzey 1884-1912:87-88, Pl. I (2)  
Steible 1982a:107 (Urn. 42)

<b>Catalog #:</b>	6	<b>Plate #:</b>	65
<b>Object Type:</b>	Relief: Plaque		
<b>Collection:</b>	Eski Sark Eserleri Müzesi, Istanbul	<b>Collection #:</b>	ES 1633 (453/4)
<b>Period:</b>	Early Dynastic IIIA	<b>Height x Width (centimeters):</b>	43 x 49.5
<b>Ruler:</b>	Urnanše		
<b>Provenance:</b>	Excavation	<b>Material:</b>	Limestone
<b>Site:</b>	Telloh (Girsu)	<b>Excavator:</b>	de Sarzec
<b>Find number:</b>			
<b>Area:</b>			
<b>Remarks:</b>	Istambul Museum catalog number is uncertain (alternate number follows original, above)		
<b>Bibliography:</b>	Boese 1971:198 (T 5), Pl. 29 (2) Braun-Holzinger 1991:309 (W4) Cooper 1986:24 (La 1.5) Moortgat 1969:Pl. 111 Parrot 1948:93, Pl. 5d Pelzel 1974:No. 79 Sollberger 1956a:2 (Urn. 23) Steible 1982a:87-88 (Urn. 23) Unger 1926:73, Fig. 5		

<b>Catalog #:</b>	7	<b>Plate #:</b>	67
<b>Object Type:</b>	Relief: Plaque		
<b>Collection:</b>	Eski Sark Eserleri Müzesi, Istanbul	<b>Collection #:</b>	ES 401
<b>Period:</b>	Early Dynastic IIIA	<b>Height x Width (centimeters):</b>	45 x 30
<b>Ruler:</b>	Urnanshe	<b>Material:</b>	Limestone
<b>Provenance:</b>	Excavation	<b>Excavator:</b>	de Sarzec
<b>Site:</b>	Telloh (Girsu)		
<b>Find number:</b>			
<b>Area:</b>	Tell K - Area and level of the "Construction d'Urnanshe" ("Maison des fruits")		
<b>Remarks:</b>	Found on the pavement outside the main structure		

**Bibliography:** Barton 1929:20 (11)  
Boese 1971:199 (T 7), Pl. 30 (2)  
Braun-Holzinger 1991:108-109 (W 3)  
Conteneau 1927:456, Fig. 349  
Cooper 1986:23-24, La 1.4  
Moortgat 1969:110  
Parrot 1948:92, Pl. 5c  
Pelzel 1974:No. 80  
de Sarzec and Heuzey 1884-1912:172-173, Pls. 2 ter (1), part. ép. 37  
Sollberger 1956a:2 (Urn. 22)  
Steible 1982a:85-86 (Urn. 22)  
Thureau-Dangin 1907:8-9 (o)

<b>Catalog #:</b>	8	<b>Plate #:</b>	174
<b>Object Type:</b>	Relief: Plaque		
<b>Collection:</b>	Eski Sark Eserleri Müzesi, Istanbul	<b>Collection #:</b>	ES 420 (426)
<b>Period:</b>	Early Dynastic IIIA	<b>Height x Width (centimeters):</b>	21 x 21
<b>Ruler:</b>	Urnanše		
<b>Provenance:</b>	Art market	<b>Material:</b>	Stone
<b>Site:</b>		<b>Excavator:</b>	None
<b>Find number:</b>			
<b>Area:</b>			
<b>Remarks:</b>	Istambul Museum catalog number is uncertain (alternate number follows original, above)		
<b>Bibliography:</b>	Boese 1971:201 (T 3) Braun-Holzinger 1991:310 (W 7) Cooper 1986:31 (La 1.26) Pelzel 1974:No. 82 de Sarzec and Heuzey 1884-1912:203-204 Sollberger 1956a:7 (Urn. 43) Steible 1982a:107 (Urn. 43) Unger 1926:75, Fig. 7		

<b>Catalog #:</b>	9	<b>Plate #:</b>	175
<b>Object Type:</b>	Relief: Plaque		
<b>Collection:</b>	Musée du Louvre	<b>Collection #:</b>	AO 51
<b>Period:</b>	Early Dynastic IIIA or IIIB	<b>Height x Width (centimeters):</b>	9 (Width)
<b>Ruler:</b>	Unknown		
<b>Provenance:</b>		<b>Material:</b>	
<b>Site:</b>	Telloh (Girsu)	<b>Excavator:</b>	de Sarzec
<b>Find number:</b>			
<b>Area:</b>	Tell A - Area of the "Tell du palais"		
<b>Remarks:</b>	Found approximately 5 meters to the southwest of the palace		
<b>Bibliography:</b>	Parrot 1948:72, Fig. 17d de Sarzec and Heuzey 1884-1912:106, Pl. 1 (3)		

<b>Catalog #:</b>	10	<b>Plate #:</b>	195
<b>Object Type:</b>	Relief: Plaque		
<b>Collection:</b>	Musée du Louvre	<b>Collection #:</b>	AO 276
<b>Period:</b>	Early Dynastic IIIB	<b>Height x Width (centimeters):</b>	17 x 15
<b>Ruler:</b>			
<b>Provenance:</b>	Excavation	<b>Material:</b>	Calcite
<b>Site:</b>	Telloh (Girsu)	<b>Excavator:</b>	de Sarzec
<b>Find number:</b>			
<b>Area:</b>			
<b>Remarks:</b>			

**Bibliography:**

Barrelet 1970:237, Fig. 5e  
Boese 1971:200 (T10), Pl. 31 (1)  
Christian 1940:Pl. 275, Fig. 1  
Conteneau 1927:484-485, Fig. 354  
Heuzey 1902:117-118, Fig. 11  
Meissner 1925:Fig. 6  
Moortgat 1969:Pl. 114  
Parrot 1948:88-89: Fig. 22b  
Pelzel 1974:No. 84  
de Sarzec and Heuzey 1884-1906:209  
Vigneau 1936 (Vol. 1):Pl. 198  
Ward 1910:159, Fig. 419  
Zervos 1935:150

<b>Catalog #:</b>	11	<b>Plate #:</b>	198
<b>Object Type:</b>	Relief: Plaque		
<b>Collection:</b>	British Museum	<b>Collection #:</b>	BM 130828
<b>Period:</b>	Early Dynastic IIIB	<b>Height x Width (centimeters):</b>	18.6 x 18.5
<b>Ruler:</b>	Enannatum I		
<b>Provenance:</b>	Art market	<b>Material:</b>	Limestone
<b>Site:</b>	Telloh (Girsu)	<b>Excavator:</b>	None
<b>Find number:</b>			
<b>Area:</b>			
<b>Remarks:</b>	Inscribed by Enannatum I.		

**Bibliography:** Boese 1971:201 (T11), Pl. 31 (2)  
Braun-Holzinger 1991:310 (W 8)  
Cooper 1986:47 (La. 4.1)  
Gadd 1951-1952:43-44, Pl. 19a  
Hansen 1975:189, Pl. 87b  
Pelzel 1974:No. 82  
Sollberger 1956a:27 (En. I 1)  
Strommenger 1964:67, Pl. 71  
Steible 1982a:182 (En. I 1)

<b>Catalog #:</b>	12	<b>Plate #:</b>	197
<b>Object Type:</b>	Relief: Plaque		
<b>Collection:</b>	Musée du Louvre	<b>Collection #:</b>	AO 4110
<b>Period:</b>	Early Dynastic IIIA or IIIB	<b>Height x Width (centimeters):</b>	25 x 20 (Uncertain, see Boese 1971)
<b>Ruler:</b>			
<b>Provenance:</b>	Excavation	<b>Material:</b>	Stone
<b>Site:</b>	Telloh (Girsu)	<b>Excavator:</b>	Cros
<b>Find number:</b>			
<b>Area:</b>	Tell K		
<b>Remarks:</b>			
<b>Bibliography:</b>	Boese 1971:202 (T 13), Pl. 31 (4) Cros 1910:32-34, Pl. 2, Fig. 2 Heuzey 1902:121-125 Parrot 1948:94-95, Fig. 22a Pelzel 1974:No. 85		

<b>Catalog #:</b>	13	<b>Plate #:</b>	87
<b>Object Type:</b>	Relief: Plaque		
<b>Collection:</b>	Musée du Louvre	<b>Collection #:</b>	AO 221
<b>Period:</b>	Early Dynastic I	<b>Height x Width (centimeters):</b>	18 x 15
<b>Ruler:</b>	Unknown		
<b>Provenance:</b>	Excavation	<b>Material:</b>	Limestone
<b>Site:</b>	Telloh (Girsu)	<b>Excavator:</b>	de Sarzec
<b>Find number:</b>			
<b>Area:</b>	Tell K - Area and level of the "Construction inférieur" ("Construction anonyme")		
<b>Remarks:</b>	Known as the "Figure aux plumes" Found on the pavement outside the main structure.		
<b>Bibliography:</b>	Amiet 1980a:Fig. 300 Caubet and Bernus-Taylor 1991:19 (bottom, right) Conteneau 1927:453, Fig. 321 Dolce 1997 Edzard 1968:173-175 (112) Gelb, Steinkeller, and Whiting 1991:66-67 (18), Pls. 32-33 Hansen 1975:184, Pl. 75 Heuzey 1900:52-53: Fig. 36 Heuzey 1902:76-79 Moortgat 1969:Pl. 30 Parrot 1948:70, Fig. 17a de Sarzec and Heuzey 1884-1912: 164-166, part . ép Pl. 34, Pl. 1bis, Figs. 1a, b, p Thureau-Dangin 1907:2 (Note No. a1) Vigneau 1936 (Vol. 1):175 (bottom) Wilcke 1991:278 Pl. (un-numbered) Wilcke 1995 Zervos 1935:53		

<b>Catalog #:</b>	14	<b>Plate #:</b>	171
<b>Object Type:</b>	Relief: Plaque		
<b>Collection:</b>	Musée du Louvre	<b>Collection #:</b>	AO 2354
<b>Period:</b>	Early Dynastic IIIB	<b>Height x Width (centimeters):</b>	25 x 22
<b>Ruler:</b>	Enmetena		
<b>Provenance:</b>	Excavation	<b>Material:</b>	Bitumin
<b>Site:</b>	Telloh (Girsu)	<b>Excavator:</b>	de Sarzec
<b>Find number:</b>			
<b>Area:</b>	Tell K - Area and level of the "Massif of Entemena"		
<b>Remarks:</b>	Inscribed by Dudu, a (sanga) priest of Ningirsu.		

**Bibliography:**

Barton 1929:54 (10)  
Boese 1971:201 (T12), Pl. 31 (3)  
Caubet and Bernus-Taylor 1991:20 (bottom)  
Christian 1940:Pl. 275, Fig. 3  
Connan 1996:124, Fig. 6  
Conteneau n.d.:Pl. 9  
Conteneau 1927:4586-487, Fig. 357  
Cooper 1986:67-68 (La 5.28)  
Heuzey 1900:79-80, Fig. 54  
Heuzey 1902:121-125, Fig. 12  
Hansen 1975:189, Pl. 88  
Kramer 1963:316 (21)  
Moortgat 1969:Pl. 117  
Parrot 1948:87-88, Fig. 22e, Pl. 7a  
Pelzel 1974:No. 83  
de Sarzec and Heuzey 1884-1906:204-209, Pl. 5bis 2  
Sollberger 1956a:44 (Ent. 76)  
Steible 1982a:266 (Ent. 76)  
Thureau-Dangin 1907:34-35 (i)  
Vigneau 1936 (Vol. 1):Pl. 207  
Zervos 1935:151

<b>Catalog #:</b>	15	<b>Plate #:</b>	177-179
<b>Object Type:</b>	Relief: Stele		
<b>Collection:</b>	Iraq Museum, Baghdad	<b>Collection #:</b>	IM 13246
<b>Period:</b>	Early Dynastic IIIA	<b>Height x Width (centimeters):</b>	25 x 25
<b>Ruler:</b>	Urnanshe		
<b>Provenance:</b>	Excavation	<b>Material:</b>	Granite
<b>Site:</b>	Ur	<b>Excavator:</b>	Woolley
<b>Find number:</b>	U. 17829		
<b>Area:</b>	To the west of the Temenos under levels dating Nebuchadnezzar		
<b>Remarks:</b>	Inscribed by Urnanshe		

**Bibliography:** Barrelet 1970:236, Fig. 5c  
Börker-Klähn 1982:123 (No. 15), Pl. 15 a-d  
Braun-Holzinger 1991:334 (Stele 4)  
Cooper 1986:32 (La 1.31)  
Sollberger 1956a:5 (Urn. 40)  
Sollberger 1960:73  
Steible 1982a:105-106 (Urn. 40)  
Woolley 1932:386-387, Pl. 74 (1)  
Woolley 1956:46, 186, Pl. 39

<b>Catalog #:</b>	16	<b>Plate #:</b>	180-182
<b>Object Type:</b>	Relief: Stele		
<b>Collection:</b>	Iraq Museum, Baghdad	<b>Collection #:</b>	IM 61404
<b>Period:</b>	Early Dynastic IIIA	<b>Height x Width (centimeters):</b>	91 x 47
<b>Ruler:</b>	Urnanše		
<b>Provenance:</b>	Art market	<b>Material:</b>	Limestone
<b>Site:</b>	Lagash (al-Hiba)	<b>Excavator:</b>	Clandestine/Unknown
<b>Find number:</b>			
<b>Area:</b>			
<b>Remarks:</b>			

**Bibliography:** Asher-Greve 1985:86-87, 91, 205, No. 556  
Barrelet 1970:236, Fig. 5d  
Basmachi 1959:21 (Photographs, Arabic article)  
Basmachi 1960:45-47, Pl. 1 (Translation of Basmachi 1959)  
Börker-Klähn 1982:123-124 (No. 16), Pl. 16a-d  
Börker-Klähn, in Hansen 1975:188, Pl. 84a-c  
Braun-Holzinger 1991:335 (Stele 5)  
Parrot 1969:17, Pl. 37  
Sollberger 1960:84, Pl. 16  
Spycket 1968:22-23: Fig. 10  
Steible 1982a:112 (Urn. 50)

<b>Catalog #:</b>	17	<b>Plate #:</b>	85
<b>Object Type:</b>	Relief: Stele		
<b>Collection:</b>	See remarks (below)	<b>Collection #:</b>	None
<b>Period:</b>	Early Dynastic I	<b>Height x Width (centimeters):</b>	85 x 200
<b>Ruler:</b>	Unknown		
<b>Provenance:</b>	Excavation	<b>Material:</b>	Calcite
<b>Site:</b>	Telloh (Girsu)	<b>Excavator:</b>	de Sarzec
<b>Find number:</b>			
<b>Area:</b>	Tell K - Area and level of the "Construction inférieur" ("Construction anonyme")		
<b>Remarks:</b>	Discovered within room 1, 60 cm from the door. Object was left in situ (i.e. abandoned) at Tello by de Sarzec.		
<b>Bibliography:</b>	Börker-Klähn 1982:117, Fig. 7 Heuzey 1895:11 Parrot 1948: 56, Fig. 14a de Sarzec and Heuzey 1884-1912:195-196, Pl. 56 (top)		

<b>Catalog #:</b>	18	<b>Plate #:</b>	103-110
<b>Object Type:</b>	Relief: Stele		
<b>Collection:</b>	Musée du Louvre	<b>Collection #:</b>	AO 50, AO 16109 AO 2346-2438
<b>Period:</b>	Early Dynastic IIIB	<b>Height x Width (centimeters):</b>	180 x 130
<b>Ruler:</b>	Eannatum		
<b>Provenance:</b>	Excavation	<b>Material:</b>	Calcite
<b>Site:</b>	Telloh (Girsu)	<b>Excavator:</b>	de Sarzec
<b>Find number:</b>			
<b>Area:</b>	Various - see 'remarks' (below)		
<b>Remarks:</b>	Known as the "Stele of the Vultures." Fragments "A" and "C" were found at the foot of Tell K, in a valley between Tells I and I'. "D", "E", and "F" were found outside the construction of Urnananshe. "B" was reused in the construction of the palace. "G" (formerly British Museum, BM 23580) was bought on the art market.		
<b>Bibliography:</b>	<p>Amiet 1980a:Figs. 328-330  Babelon 1888:35-37: Figs. 11-1  Barton 1929:22 (1)  Barrelet 1970  Börker-Klähn 1982:124-125 (no. 17),  Pls. 17 a-d  Christian 1940:Pls. 255-266  Conteneau n.d.: Pls. 4-5  Conteneau 1927:479-483,  Figs. 351-352  Cooper 1986:33-39(La 3.1)  Edzard 1975:63-98  Edzard 1991:74-75, Pls. (un-numbered)  Falkner 1967-1971:194  Frankfort 1969:33-34, Pls. 34-35  Groenewegen-Frankfort 1951:  158-160, Pl. 57a-b  Hansen 1975: 89a, 90, 91  Heuzey 1894:55-58, Fig. 2, Pl.3  Heuzey 1900:21-23, Fig. 12  Heuzey 1902:101-117 (No. 10)  Heuzey and Thureau-Dangin1909  Hrouda 1971:Pls. 47a-b  Jacobsen 1976b:247-259</p> <p>Perkins 1957:57-58, Pl. 18  Perrot, Chipiez et. al. 1884:590-591,  Figs. 283-285  de Sarzec and Heuzey 1884-1912:36,  68, 94-103, 174-195, 357-378,  Pls. 3-4ter, 48, 48bis, ép. 37-42  Schäfer and Andre 1930: Pls. 456-457  Sollberger 1956a:9-16 (Ean. 1)  Sollberger 1957-1971:194-195  Sollberger and Kupper 1971:47-58 (IC5a)  Solyman 1968:135-136, Pls. 19(187)  41 (253), 42 (256), 45 (265)  Steible 1982a:120-145 (Ean. 1)  Strommenger 1964:Pl. 66-67  Thureau-Dangin 1907:160-161 (2)  Unger 1926: 69, Fig. 1  Vigneau 1936 (Vol. 1):190-194  Ward 1910:34-35, Figs. 75-76  Winter 1986a:205-212  Winter 1986b  Zervos 1935:106-112</p>		

<b>Catalog #:</b>	19	<b>Plate #:</b>	84
<b>Object Type:</b>	Relief: Stele		
<b>Collection:</b>	Musée du Louvre	<b>Collection #:</b>	Unknown
<b>Period:</b>	Early Dynastic I	<b>Height x Width (centimeters):</b>	Unknown
<b>Ruler:</b>	Unknown		
<b>Provenance:</b>	Excavation	<b>Material:</b>	Stone
<b>Site:</b>	Telloh (Girsu)	<b>Excavator:</b>	de Sarzec
<b>Find number:</b>			
<b>Area:</b>	Tell K - Area and level of the "Construction inférieur" ("Construction anonyme")		
<b>Remarks:</b>	Inscribed with a land tenure document. Apparently this has been lost inside the museum (see comment in Gelb et al. 1991:67).		
<b>Bibliography:</b>	Gelb, Steinkeller, and Whiting 1991:67-68, No. 19 Heuzey 1900:53, Fig 35a-b Parrot 1948:56-57 de Sarzec and Heuzey 1884-1912:Pl. 35 (2a and 2b), 414, Pl. 1ter 6		

<b>Catalog #:</b>	20	<b>Plate #:</b>	79-83
<b>Object Type:</b>	Relief: Base		
<b>Collection:</b>	Musée du Louvre	<b>Collection #:</b>	AO 2350, 3288
<b>Period:</b>	Early Dynastic I	<b>Height x Width (centimeters):</b>	19 (Height) x 39 (Diameter)
<b>Ruler:</b>			
<b>Provenance:</b>	Excavation	<b>Material:</b>	Calcite
<b>Site:</b>	Telloh (Girsu)	<b>Excavator:</b>	de Sarzec
<b>Find number:</b>			
<b>Area:</b>	Tell K - Area and level of the "Construction inférieur" ("Construction anonyme")		
<b>Remarks:</b>	Diameter is 39 cm. Discovered in parts. One piece was in the great hall of the "Construction inférieur", the others fragments were on the same level. Known as the "Circular Relief."		
<b>Bibliography:</b>	Braun-Holzinger 1991:347 (Sockle 1) Conteneau 1927:424-455, Figs. 322-326 Christian 1940:Pl. 267 Heuzey 1900:53-56, Figs-39 Heuzey 1902:82-91, Fig. 5 King 1910:45-46, Figs. 9-11 Parrot 1948:56-57, 72-73, Figs. 14(b, i-k), 17e de Sarzec and Heuzey 1884-1912:166, 196, 353-357, Pls. 1bis (2), 1ter (5a,b), 47 (1), part ép. Pl. 135 Solyman 1968:138, Pl. 87(461) Strommenger 1964:44 Thureau-Dangin 1907:2 (Note No. a4) Ward 1910:30, Fig. 53 Zervos 1935:55-57		

<b>Catalog #:</b>	21	<b>Plate #:</b>	114
<b>Object Type:</b>	Relief: Fragment		
<b>Collection:</b>	Musée du Louvre	<b>Collection #:</b>	AO 48
<b>Period:</b>	Early Dynastic I	<b>Height x Width (centimeters):</b>	18 x 25
<b>Ruler:</b>			
<b>Provenance:</b>	Excavation	<b>Material:</b>	Stone
<b>Site:</b>	Telloh (Girsu)	<b>Excavator:</b>	de Sarzec
<b>Find number:</b>			
<b>Area:</b>	Valley between Tell K and Tell J		
<b>Remarks:</b>	Found not far from two fragments of the Stele of the Vultures.		

**Bibliography:** Barrelet 1970:237, Pl. 17, Fig. 5b  
Babelon 1888:33-34, Fig. 9  
Boese 1971:199 (T 8), Fig. 30 (3)  
Conteneau 1927:455, Fig. 327  
Hansen 1975:189, Pl. 89a  
Legrain 1929:229-230, Pl. 10(b)  
Heuzey 1902:79-80, No. 2  
Parrot 1948:70-71, Fig. 17c  
de Sarzec and Heuzey 1884-1912:103, Pl. 1 (1)  
Zervos 1935:Pl. 60

<b>Catalog #:</b>	22	<b>Plate #:</b>	92
<b>Object Type:</b>	Standard		
<b>Collection:</b>	See remarks (below)	<b>Collection #:</b>	None
<b>Period:</b>	Early Dynastic IIIA or IIIB	<b>Height x Width (centimeters):</b>	327 x 10 (Diameter)
<b>Ruler:</b>			
<b>Provenance:</b>	Excavation	<b>Material:</b>	Copper
<b>Site:</b>	Telloh (Girsu)	<b>Excavator:</b>	de Sarzec
<b>Find number:</b>			
<b>Area:</b>	Tell K - Area and level of the "Construction d' Urnanše" ("Maison des fruits")		
<b>Remarks:</b>	Found on the stone pavement outside the main structure. "Lost" during transportation.		
<b>Bibliography:</b>	Conteneau 1931:588, Figs. 395 Heuzey 1900:26 Parrot 1948:106, Fig. 26c de Sarzec and Heuzey 1884-1912:41, Pl. 57 (1)		

<b>Catalog #:</b>	23	<b>Plate #:</b>	160
<b>Object Type:</b>	Sculpture: Human		
<b>Collection:</b>	British Museum	<b>Collection #:</b>	BM 90929
<b>Period:</b>	Early Dynastic IIIB	<b>Height x Width (centimeters):</b>	30.5 (Height)
<b>Ruler:</b>	Unknown		
<b>Provenance:</b>	Art market	<b>Material:</b>	Stone
<b>Site:</b>		<b>Excavator:</b>	Clandestine/Unknown
<b>Find number:</b>			
<b>Area:</b>			
<b>Remarks:</b>	Braun-Holzinger classifies this as "Stilstufe III" (1977:61).		
<b>Bibliography:</b>	Braun-Holzinger 1977:61, Pl 25 a-b Conteneau 1931:560, Fig. 370 Hall 1928:29, Pl. V (bottom) Hansen 1975:168, Pl 32a-b King 1910:40 Moortgat 1969:Pls. 101-102 Parrot 1948:82, Pl. IV c Spycket 1981:Pl. 79 Zervos 1935:Pls. 124-125		

<b>Catalog #:</b>	24	<b>Plate #:</b>	163
<b>Object Type:</b>	Sculpture: Human		
<b>Collection:</b>	Iraq Museum, Baghdad	<b>Collection #:</b>	IM 5
<b>Period:</b>	Early Dynastic IIIB	<b>Height x Width (centimeters):</b>	76 (Height)
<b>Ruler:</b>	Enmetena		
<b>Provenance:</b>	Excavation	<b>Material:</b>	Diorite
<b>Site:</b>	Ur	<b>Excavator:</b>	Woolley
<b>Find number:</b>	U. 805		
<b>Area:</b>	Found near the entranceway of Nabonidus in Neo-Babylonian levels		
<b>Remarks:</b>	Inscribed by Enmetena.		

**Bibliography:**

Amiet 1980a:Fig. 331  
Braun-Holzinger 1977:56, 61, 73, 80,Pl. 27d  
Braun-Holzinger 1991:240-241(St 3)  
Christian 1940:Pl. 256  
Conteneau 1931:561,Fig. 371  
Cooper 1986:63 (La 5.17)  
Gadd and Legrain 1928:ix (1), 1, 2, Pl. 1  
Hansen 1975:167-168: Pl. 31  
Parrot 1948:81, Pl. 4b  
Woolley 1956:47, Pl. 40  
Moortgat 1969:Pl. 87-88  
Sollberger 1956a:32 (Ent. 1)  
Sollberger 1960:75  
Sollberger and Kupper 1971:66-67 (IC7a)  
Spycket 1981:84, Pl. 54  
Steible 1982a:211-213 (Ent. 1)  
Unger 1926:84, Figs. 22-23

<b>Catalog #:</b>	25	<b>Plate #:</b>	162
<b>Object Type:</b>	Sculpture: Human		
<b>Collection:</b>	Iraq Museum, Baghdad	<b>Collection #:</b>	IM 51145
<b>Period:</b>	Early Dynastic IIIB	<b>Height x Width (centimeters):</b>	23.5 (Height)
<b>Ruler:</b>	Enannatum I		
<b>Provenance:</b>	Art market	<b>Material:</b>	Stone
<b>Site:</b>	Telloh (Girsu)	<b>Excavator:</b>	Clandestine/Unknown
<b>Find number:</b>			
<b>Area:</b>			
<b>Remarks:</b>	Inscribed by the brother of Enmetena: "(M)ean(si), son of Enannatum I of Lagaš..."		

**Bibliography:** Basmachi and Edzard 1958:109-113, Pls. 1-4  
Braun-Holzinger 1977:56, Pl. 27 e  
Braun-Holzinger 1991:240 (St 2)  
Spycket 1981:84, Fig. 201  
Steible 1982a:195-196 (Ent. 2)  
Strommenger 1964:401, Pl. 101

<b>Catalog #:</b>	26	<b>Plate #:</b>	165
<b>Object Type:</b>	Sculpture: Human		
<b>Collection:</b>	Eski Sark Eserleri Müzesi, Istanbul	<b>Collection #:</b>	ES 1581
<b>Period:</b>	Early Dynastic IIIB	<b>Height x Width (centimeters):</b>	48 (Height)
<b>Ruler:</b>			
<b>Provenance:</b>	Excavation	<b>Material:</b>	Alabaster
<b>Site:</b>	Telloh (Girsu)	<b>Excavator:</b>	de Sarzec
<b>Find number:</b>			
<b>Area:</b>	Tell V - Area of the "Tell des tablettes"		
<b>Remarks:</b>	Braun-Holzinger classifies this as "Stilstufe III" (1977:61).		

**Bibliography:** Braun-Holzinger 1977:61, 80  
Conteneau 1931:559, Figs. 369  
Parrot 1948:80, Pl. 4a  
de Sarzec and Heuzey 1884-1912:333-335, Pl. 6bis (1a, b, c)  
Unger 1926:81, Fig. 19  
Zervos 1935:Pl. 100

<b>Catalog #:</b>	27	<b>Plate #:</b>	157-158
<b>Object Type:</b>	Sculpture: Human		
<b>Collection:</b>	Musée du Louvre	<b>Collection #:</b>	AO 3279-80, 4494
<b>Period:</b>	Early Dynastic IIIA	<b>Height x Width (centimeters):</b>	40 (Height)
<b>Ruler:</b>			
<b>Provenance:</b>	Excavation	<b>Material:</b>	Diorite
<b>Site:</b>	Telloh (Girsu)	<b>Excavator:</b>	de Sarzec
<b>Find number:</b>			
<b>Area:</b>	Tell V - Area of the "Tell des tablettes"		
<b>Remarks:</b>	Discovered in several pieces. Inscribed by Lupad of Umma with a land tenure document. Dates to the period of the 'Fara texts' (i.e., ED IIIA).		
<b>Bibliography:</b>	Conteneau 1931:565-566, Figs. 375 Garbini 1962:Pl. 22 Gelb, Steinkeller, and Whiting 1991:72-74 (No. 21), Pls. 38-39 Heuzey 1902:189-190 Moortgat 1969:Pl. 108 Parrot 1948:78, Fig. 19 a de Sarzec and Heuzey 1884-1912:327, 448, PL. 6ter (47) Spycket 1981:Pl. 67 Zervos 1935:97		

<b>Catalog #:</b>	28	<b>Plate #:</b>	164
<b>Object Type:</b>	Sculpture: Human		
<b>Collection:</b>	Iraq Museum, Baghdad	<b>Collection #:</b>	IM 55204
<b>Period:</b>	Early Dynastic IIIB	<b>Height x Width (centimeters):</b>	39 (Height)
<b>Ruler:</b>			
<b>Provenance:</b>	Art market	<b>Material:</b>	Stone
<b>Site:</b>	Lagash (al-Hiba)	<b>Excavator:</b>	None

**Find number:**

**Area:**

**Remarks:** Offering to Ningirsu by the scribe Dudu.  
Braun-Holzinger classifies this as "Stilstufe III" (1977:62).

**Bibliography:** al-Asil 1941:131-132; Pls. 1-5  
Amiet 1980a:Fig. 297  
Braun-Holzinger 1991:241 (St 5)  
Braun-Holzinger 1977:62, 74, 82  
Hansen 1975: 29  
Moortgat 1969:40,Pl. 103  
Renger 1991:186-187, Pl. (not numbered)  
Safar 1949:133-134  
Sollberger 1957:62-64  
Spycket 1981:105  
Steible 1982a:361  
Strommenger 1960:33  
Strommenger 1964:Pls. 86-87

<b>Catalog #:</b>	29	<b>Plate #:</b>	168
<b>Object Type:</b>	Sculpture: Human		
<b>Collection:</b>	Musée du Louvre	<b>Collection #:</b>	AO 222
<b>Period:</b>	Early Dynastic IIIB	<b>Height x Width (centimeters):</b>	22 (Height)
<b>Ruler:</b>			
<b>Provenance:</b>	Art market	<b>Material:</b>	Gypsum
<b>Site:</b>	Telloh (Girsu)	<b>Excavator:</b>	Clandestine/Unknown
<b>Find number:</b>			
<b>Area:</b>			
<b>Remarks:</b>	Purchased in Shatra by de Sarzec. Braun-Holzinger classifies this as "Stilstufe III" (1977:61).		
<b>Bibliography:</b>	Braun-Holzinger 1977:61,80 Christian 1940:Pl. 255 (1a-b) Conteneau 1931:552-553, Figs. 360-361 Moortgat 1969:40, Pl. 99-100 Parrot 1948:82, Fig. 20a-a' de Sarzec and Heuzey 1884-1912:Pl. 1ter (3a-b) Spycket 1981:114, Pl. 77 Zervos 1935:Pl. 98		

**Catalog #:** 30 **Plate #:** 161

**Object Type:** Sculpture: Human

**Collection:** Musée du Louvre **Collection #:** AO 9060

**Period:** Early Dynastic IIIB **Height x Width (centimeters):** 20.5 (Height)

**Ruler:**

**Provenance:** Art market **Material:** Alabaster

**Site:** Telloh (Girsu) **Excavator:** Clandestine/Unknown

**Find number:**

**Area:**

**Remarks:** Acquired in 1924.

**Bibliography:** Christian 1940:Pl. 255 (2a-b)  
Conteneau n. d.:Pl. 2  
Conteneau 1931:547-550, Figs. 358-359  
Parrot 1948: 78, Fig. 19c  
Vigneau 1936 (Vol. 1):Pl. 182  
Zervos 1935:116-117

<b>Catalog #:</b>	31	<b>Plate #:</b>	166
<b>Object Type:</b>	Sculpture: Human		
<b>Collection:</b>	Eski Sark Eserleri Müzesi, Istanbul	<b>Collection #:</b>	ES 1598
<b>Period:</b>	Early Dynastic IIIB	<b>Height x Width (centimeters):</b>	24.5 (Height)
<b>Ruler:</b>			
<b>Provenance:</b>	Excavation	<b>Material:</b>	Gypsum
<b>Site:</b>	Telloh (Girsu)	<b>Excavator:</b>	de Sarzec
<b>Find number:</b>			
<b>Area:</b>	Tell V - Area of the "Tell des tablettes"		
<b>Remarks:</b>			
<b>Bibliography:</b>	Moortgat 1969:Pls. 99-100 Parrot 1948:78-80, Fig. 19b de Sarzec and Heuzey 1884-1912:47, Pl. 21ter (3) Unger 1926:72, Pl. 4		

<b>Catalog #:</b>	32	<b>Plate #:</b>	159
<b>Object Type:</b>	Sculpture: Human		
<b>Collection:</b>	Musée du Louvre	<b>Collection #:</b>	AO 300
<b>Period:</b>	Early Dynastic IIIA	<b>Height x Width (centimeters):</b>	8 (Height)
<b>Ruler:</b>			
<b>Provenance:</b>	Excavation	<b>Material:</b>	Alabaster
<b>Site:</b>	Telloh (Girsu)	<b>Excavator:</b>	de Sarzec
<b>Find number:</b>			
<b>Area:</b>	Tell K		
<b>Remarks:</b>	The head of a woman.		

**Bibliography:** Conteneau 1931: 373-374, Figs. 383  
Heuzey 1902:219, Fig. 80  
Parrot 1948:82, Fig. 20c  
de Sarzec and Heuzey 1884-1912:337, Pl. 24bis (1a-b)  
Spycket 1981:Pls. 78a-b  
Vigneau 1936 (Vol. 1):Pl. 205d  
Zervos 1935:Pl. 149

<b>Catalog #:</b>	33	<b>Plate #:</b>	167
<b>Object Type:</b>	Sculpture: Human		
<b>Collection:</b>	Musée du Louvre	<b>Collection #:</b>	AO 11
<b>Period:</b>	Early Dynastic IIIB	<b>Height x Width (centimeters):</b>	30 (Height)
<b>Ruler:</b>			
<b>Provenance:</b>	Excavation	<b>Material:</b>	Diorite
<b>Site:</b>	Telloh (Girsu)	<b>Excavator:</b>	de Sarzec
<b>Find number:</b>			
<b>Area:</b>	Tell A - Area of the "Tell du palais" (?)		
<b>Remarks:</b>	Find spot uncertain. Similar in style to the statue of Enmetena in Iraq Museum (IM 5).		
<b>Bibliography:</b>	Parrot 1948:81-82, Fig. 19h de Sarzec and Heuzey 1884-1912:149, Pl. 21ter (4)		

<b>Catalog #:</b>	34	<b>Plate #:</b>	151
<b>Object Type:</b>	Sculpture: Lion		
<b>Collection:</b>	Eski Sark Eserleri Müzesi, Istanbul	<b>Collection #:</b>	ES 458
<b>Period:</b>	Early Dynastic IIIA	<b>Height x Width (centimeters):</b>	9 x 12
<b>Ruler:</b>	Akurgal	<b>Material:</b>	Gypsum
<b>Provenance:</b>	Excavation	<b>Excavator:</b>	de Sarzec
<b>Site:</b>	Telloh (Girsu)		
<b>Find number:</b>			
<b>Area:</b>			
<b>Remarks:</b>	Presumed to have the same inscription as the lion in the collection of the Louvre (AO 3295). Discovered 4.50 meters from the west corner on "Pavement F " outside the main structure , on the ground level of Urnanše.		
<b>Bibliography:</b>	Braun-Holzinger 1991:325 (T5) Cooper 1986:33 (La 2.1) Parrot 1948:86, Fig. 21d Sollberger 1956a:8 (Akg. 2) Steible 1982a:118 (Akurgal 2) Unger 1926:80, Fig. 15 (Left)		

<b>Catalog #:</b>	35	<b>Plate #:</b>	152
<b>Object Type:</b>	Sculpture: Lion		
<b>Collection:</b>	Eski Sark Eserleri Müzesi, Istanbul	<b>Collection #:</b>	ES 457
<b>Period:</b>	Early Dynastic IIIA	<b>Height x Width (centimeters):</b>	9 (Height)
<b>Ruler:</b>	Akurgal		
<b>Provenance:</b>	Excavation	<b>Material:</b>	Gypsum
<b>Site:</b>	Telloh (Girsu)	<b>Excavator:</b>	de Sarzec
<b>Find number:</b>			
<b>Area:</b>	Tell K - Area and level of the "Construction d' Urnanše" ("Maison des fruits")		
<b>Remarks:</b>	Discovered 4.50 meters from the west corner on "Pavement F " outside the main structure, on the ground level of Urnanše.		
<b>Bibliography:</b>	Braun-Holzinger 1991:325 (T5) Parrot 1948:86, Fig. 21e Steible 1982a:118-119 (Akurgal 3) Unger 1926:80, Fig. 16 (Right)		

<b>Catalog #:</b>	36	<b>Plate #:</b>	None
<b>Object Type:</b>	Sculpture: Lion		
<b>Collection:</b>	Musée du Louvre	<b>Collection #:</b>	AO 3295
<b>Period:</b>	Early Dynastic IIIA	<b>Height x Width (centimeters):</b>	9 x 17
<b>Ruler:</b>	Akurgal		
<b>Provenance:</b>	Excavation	<b>Material:</b>	Alabaster
<b>Site:</b>	Telloh (Girsu)	<b>Excavator:</b>	de Sarzec
<b>Find number:</b>			
<b>Area:</b>	Tell V - Area of the "Tell des tablettes"		
<b>Remarks:</b>	No photographs or drawings of this object have ever been published. Heuzey (1902:263) describes this object as "très mutilé." Object is inscribed.		
<b>Bibliography:</b>	Braun-Holzinger 1991:324 (T 4) Cooper 1986:33 (La 2.1) Heuzey 1902:263, No. 115 Parrot 1948:86 de Sarzec and Heuzey 1884-1912:351, ép. 54 Sollberger 1956a:8 (Akg. 1) Steible 1982a:118 (Akurgal 1)		

<b>Catalog #:</b>	37	<b>Plate #:</b>	96
<b>Object Type:</b>	Sculpture: Lion		
<b>Collection:</b>	Musée du Louvre	<b>Collection #:</b>	AO 3281
<b>Period:</b>	Early Dynastic I	<b>Height x Width (centimeters):</b>	8 x 10
<b>Ruler:</b>	Urnanše		
<b>Provenance:</b>	Excavation	<b>Material:</b>	Onyx
<b>Site:</b>	Telloh (Girsu)	<b>Excavator:</b>	de Sarzec
<b>Find number:</b>			
<b>Area:</b>	Tell K - Area and level of the "Construction inférieur" ("Construction anonyme")		
<b>Remarks:</b>	Inscribed votive offering of Urnanše to Ningirsu. Discovered 4.50 meters from the west corner on "Pavement F," outside the main structure , on the ground level of Urnanše.		
<b>Bibliography:</b>	Amiet 1980a:Fig. 399 Braun-Holzinger 1991:324 (T. 1) Christian 1940:Pl. 260 (5a-b) Conteneau 1931:582-584, Fig. 388 Cooper 1986:30 (La 1.24) Heuzey 1902:261-262, Fig. 118 Parrot 1948:56, 84, Figs. 14g and 21a de Sarzec and Heuzey 1884-1912: 350-352, Pl. 6ter (3a-b) Sollberger 1956a:7 (Urn 44)		

<b>Catalog #:</b>	38	<b>Plate #:</b>	94
<b>Object Type:</b>	Sculpture: Lion		
<b>Collection:</b>	Musée du Louvre	<b>Collection #:</b>	AO 233
<b>Period:</b>	Early Dynastic IIIA	<b>Height x Width (centimeters):</b>	9 (Height)
<b>Ruler:</b>	Urnanše		
<b>Provenance:</b>	Excavation	<b>Material:</b>	Calcite
<b>Site:</b>	Telloh (Girsu)	<b>Excavator:</b>	de Sarzec
<b>Find number:</b>			
<b>Area:</b>	Tell K - Area and level of the "Construction d' Urnanše" ("Maison des fruits")		
<b>Remarks:</b>	Inscribed by Urnanše. Discovered 4.50 meters from the West corner on "Pavement F" outside the main structure, on the ground level of Urnanše.		
<b>Bibliography:</b>	Braun-Holzinger 1991:324 (T 2) Cooper 1986:30 (La 1.24) Heuzey 1897:105, Fig. 10a Heuzey 1902:260-261, Fig. 113 Heuzey 1900:19-20, Fig. 10a Parrot 1948:61,84, Fig. 21b de Sarzec and Heuzey 1884-1912:228, Pl. 23bis (4) Sollberger 1956a:7 (Urn. 45) Steible 1982a:108 (Urn. 45)		

<b>Catalog #:</b>	39	<b>Plate #:</b>	97
<b>Object Type:</b>	Sculpture: Lion		
<b>Collection:</b>	Eski Sark Eserleri Müzesi, Istanbul	<b>Collection #:</b>	ES 456
<b>Period:</b>	Early Dynastic IIIA	<b>Height x Width (centimeters):</b>	20 x 9
<b>Ruler:</b>	Urnanše		
<b>Provenance:</b>	Excavation	<b>Material:</b>	Onyx
<b>Site:</b>	Telloh (Girsu)	<b>Excavator:</b>	de Sarzec
<b>Find number:</b>			
<b>Area:</b>	Tell K - Area and level of the "Construction d' Urnanše" ("Maison des fruits")		
<b>Remarks:</b>	Inscribed "[...He had] ships of Dilmun trans[port] timber from foreign lands (to Lagaš)." Discovered 4.50 meters from the West corner on "Pavement F" outside the main structure, on the ground level of Urnanše.		
<b>Bibliography:</b>	Braun-Holzinger 1991:324 (T 3) Conteneau 1931:582-584, Fig. 387 Cooper 1986:30 (La 1.25) Heuzey 1897:105, Fig. 10b Heuzey 1900:19-20, Fig. 10b Sollberger 1956a:7 (Urn 46) Steible 1982a:109 (Urn. 46)		

<b>Catalog #:</b>	40	<b>Plate #:</b>	93
<b>Object Type:</b>	Sculpture: Lion		
<b>Collection:</b>	Musée du Louvre	<b>Collection #:</b>	AO 231
<b>Period:</b>	Early Dynastic IIIA	<b>Height x Width (centimeters):</b>	7 (Height)
<b>Ruler:</b>	Urnanshe		
<b>Provenance:</b>	Excavation	<b>Material:</b>	Calcite
<b>Site:</b>	Telloh (Girsu)	<b>Excavator:</b>	de Sarzec
<b>Find number:</b>			
<b>Area:</b>	Tell K - Area and level of the "Construction d' Urnanshe" ("Maison des fruits")		
<b>Remarks:</b>	Discovered 4.50 meters from the west corner on "Pavement F " outside the main structure , on the ground level of Urnanshe.		
<b>Bibliography:</b>	Conteneau 1931:582-584, Fig. 389 Heuzey 1900:19-20, Fig10c Heuzey 1902:283 Parrot 1948:84, Fig. 21c de Sarzec and Heuzey 1884-1912:228, Pl. 25bis (5)		

<b>Catalog #:</b>	41	<b>Plate #:</b>	102
<b>Object Type:</b>	Sculpture: Bull Head		
<b>Collection:</b>	Musée du Louvre	<b>Collection #:</b>	AO 2676
<b>Period:</b>	Early Dynastic IIIA	<b>Height x Width (centimeters):</b>	19 (Height)
<b>Ruler:</b>			
<b>Provenance:</b>	Excavation	<b>Material:</b>	Copper
<b>Site:</b>	Telloh (Girsu)	<b>Excavator:</b>	de Sarzec
<b>Find number:</b>			
<b>Area:</b>	Tell K - Area and level of the "Construction d' Urnanše" ("Maison des fruits")		
<b>Remarks:</b>	Found on the pavement 16 m from the SE corner of the building approximately .25 meters below the foundation level. Probably a fitting for a lyre. Originally one of two such heads (the location of the other now appears to be unknown).		
<b>Bibliography:</b>	Caubet and Bernus-Taylor 1991:23 (top) Conteneau 1931:594-595, Fig. 400 Parrot 1948:106, Fig. 26a Heuzey 1898:26-29, Pl. 2 Heuzey 1900:37-38, Fig. 23 Heuzey 1902:318-321 de Sarzec and Heuzey 1884-1912:238, Pl. 5ter (2a,b)		

<b>Catalog #:</b>	42	<b>Plate #:</b>	117
<b>Object Type:</b>	Inlay		
<b>Collection:</b>	Musée du Louvre	<b>Collection #:</b>	AO 4109
<b>Period:</b>	Early Dynastic IIIA	<b>Height x Width (centimeters):</b>	7 (Height)
<b>Ruler:</b>	Urnanše		
<b>Provenance:</b>	Excavation	<b>Material:</b>	Shell
<b>Site:</b>	Telloh (Girsu)	<b>Excavator:</b>	Cros
<b>Find number:</b>			
<b>Area:</b>	Tell K - Area and level of "Les bassins"		
<b>Remarks:</b>	Inscribed "Urnanše, king of Lagaš."		

**Bibliography:** Barton 1929:20 (13)  
Cooper 1986:22 (La 1.1)  
Cros 1919:13, 31-32, Pl .2(1)  
Parrot 1948:111, Fig. 27a  
Sollberger 1956a:2 (Urn. 1)  
Steible 1982a:79 (Urn. 1)

<b>Catalog #:</b>	43	<b>Plate #:</b>	118
<b>Object Type:</b>	Inlay		
<b>Collection:</b>	Musée du Louvre	<b>Collection #:</b>	AO 201
<b>Period:</b>	Early Dynastic IIIA or IIIB	<b>Height x Width (centimeters):</b>	6 (Height)
<b>Ruler:</b>			
<b>Provenance:</b>	Excavation	<b>Material:</b>	Shell
<b>Site:</b>	Telloh (Girsu)	<b>Excavator:</b>	de Sarzec
<b>Find number:</b>			
<b>Area:</b>			
<b>Remarks:</b>			

**Bibliography:** Heuzey 1902:391  
Parrot 1948:111, Fig. 27c  
de Sarzec and Heuzey 1884-1912:267, Pl. 46 (5)  
Vigneau 1936:186b

<b>Catalog #:</b>	44	<b>Plate #:</b>	119
<b>Object Type:</b>	Inlay		
<b>Collection:</b>	Musée du Louvre	<b>Collection #:</b>	AO 202
<b>Period:</b>	Early Dynastic IIIA or IIIB	<b>Height x Width (centimeters):</b>	7 (Height)
<b>Ruler:</b>			
<b>Provenance:</b>	Excavation	<b>Material:</b>	Shell
<b>Site:</b>	Telloh (Girsu)	<b>Excavator:</b>	de Sarzec
<b>Find number:</b>			
<b>Area:</b>	Tell K - Area and level of the "Puits d'Eannadu"		
<b>Remarks:</b>			

**Bibliography:** Heuzey 1900:72, Fig. 51  
Heuzey 1902:387  
Parrot 1948:111, Fig. 27e  
de Sarzec and Heuzey 1884-1912:267, Pl. 46 (3)  
Vigneau 1936:186a

<b>Catalog #:</b>	45	<b>Plate #:</b>	120
<b>Object Type:</b>	Inlay		
<b>Collection:</b>	Musée du Louvre	<b>Collection #:</b>	AO 206
<b>Period:</b>	Early Dynastic IIIA or IIIB	<b>Height x Width (centimeters):</b>	3.5 (Height)
<b>Ruler:</b>			
<b>Provenance:</b>	Excavation	<b>Material:</b>	Shell
<b>Site:</b>	Telloh (Girsu)	<b>Excavator:</b>	de Sarzec
<b>Find number:</b>			
<b>Area:</b>			
<b>Remarks:</b>			

**Bibliography:** Parrot 1948:111, Fig. 27d  
de Sarzec and Heuzey 1884-1912:267, Pl. 46 (4)  
Vigneau 1936:187f

<b>Catalog #:</b>	46	<b>Plate #:</b>	121
<b>Object Type:</b>	Inlay		
<b>Collection:</b>	Musée du Louvre	<b>Collection #:</b>	AO 203
<b>Period:</b>	Early Dynastic IIIA or IIIB	<b>Height x Width (centimeters):</b>	4.5 (Height)
<b>Ruler:</b>			
<b>Provenance:</b>	Excavation	<b>Material:</b>	Shell
<b>Site:</b>	Telloh (Girsu)	<b>Excavator:</b>	de Sarzec
<b>Find number:</b>			
<b>Area:</b>			
<b>Remarks:</b>			

**Bibliography:** Heuzey 1902:392  
Parrot 1948:112, Fig. 27b  
de Sarzec and Heuzey 1884-1912:267, Pl. 46 (2)  
Vigneau 1936:187d

<b>Catalog #:</b>	47	<b>Plate #:</b>	122
<b>Object Type:</b>	Inlay		
<b>Collection:</b>	Musée du Louvre	<b>Collection #:</b>	AO 329 [B]
<b>Period:</b>	Early Dynastic IIIA or IIIB	<b>Height x Width (centimeters):</b>	6 (Height)
<b>Ruler:</b>			
<b>Provenance:</b>	Excavation	<b>Material:</b>	Mother of Pearl
<b>Site:</b>	Telloh (Girsu)	<b>Excavator:</b>	de Sarzec
<b>Find number:</b>			
<b>Area:</b>			
<b>Remarks:</b>	Inventory number is either incorrect, or it is shared with a separate inlay. The "B" in brackets, after the Louvre inventory number, has been added by the present author to avoid confusion.		
<b>Bibliography:</b>	Heuzey 1902:392 Parrot 1948:114, Fig. 27k de Sarzec and Heuzey 1884-1912:271, Fig. B Vigneau 1936:187d		

<b>Catalog #:</b>	48	<b>Plate #:</b>	123
<b>Object Type:</b>	Inlay		
<b>Collection:</b>	Musée du Louvre	<b>Collection #:</b>	AO 207 a
<b>Period:</b>	Early Dynastic IIIA or IIIB	<b>Height x Width (centimeters):</b>	2.4 (Height)
<b>Ruler:</b>			
<b>Provenance:</b>	Excavation	<b>Material:</b>	Shell
<b>Site:</b>	Telloh (Girsu)	<b>Excavator:</b>	de Sarzec
<b>Find number:</b>			
<b>Area:</b>			
<b>Remarks:</b>			

**Bibliography:** Heuzey 1902:397  
Parrot 1948:112, Fig. 27f  
de Sarzec and Heuzey 1884-1912:269, Pl. 46 (6)

<b>Catalog #:</b>	49	<b>Plate #:</b>	124
<b>Object Type:</b>	Inlay		
<b>Collection:</b>	Musée du Louvre	<b>Collection #:</b>	AO 205
<b>Period:</b>	Early Dynastic IIIA or IIIB	<b>Height x Width (centimeters):</b>	5 (Height)
<b>Ruler:</b>			
<b>Provenance:</b>	Excavation	<b>Material:</b>	Shell
<b>Site:</b>	Telloh (Girsu)	<b>Excavator:</b>	de Sarzec
<b>Find number:</b>			
<b>Area:</b>			
<b>Remarks:</b>			
<b>Bibliography:</b>	Heuzey 1902:397 Parrot 1948:111, Fig. 27h de Sarzec and Heuzey 1884-1912:269, Pl. 46 (8)		

<b>Catalog #:</b>	50	<b>Plate #:</b>	125
<b>Object Type:</b>	Inlay		
<b>Collection:</b>	Musée du Louvre	<b>Collection #:</b>	AO 204
<b>Period:</b>	Early Dynastic IIIA or IIIB	<b>Height x Width (centimeters):</b>	5 (Height)
<b>Ruler:</b>			
<b>Provenance:</b>	Excavation	<b>Material:</b>	Shell
<b>Site:</b>	Telloh (Girsu)	<b>Excavator:</b>	de Sarzec
<b>Find number:</b>			
<b>Area:</b>			
<b>Remarks:</b>			

**Bibliography:** Heuzey 1902:396  
Parrot 1948:112, Fig. 27i  
de Sarzec and Heuzey 1884-1912:268, Pl. 46 (1)

<b>Catalog #:</b>	51	<b>Plate #:</b>	126
<b>Object Type:</b>	Inlay		
<b>Collection:</b>	Musée du Louvre	<b>Collection #:</b>	Unknown
<b>Period:</b>	Early Dynastic IIIA or IIIB	<b>Height x Width (centimeters):</b>	6 (Height)
<b>Ruler:</b>			
<b>Provenance:</b>	Excavation	<b>Material:</b>	Mother of Pearl
<b>Site:</b>	Telloh (Girsu)	<b>Excavator:</b>	de Sarzec
<b>Find number:</b>			
<b>Area:</b>			
<b>Remarks:</b>			

**Bibliography:** Heuzey 1902:403  
Parrot 1948:114, Fig. 27n  
de Sarzec and Heuzey 1884-1912:271-272, Fig. D

<b>Catalog #:</b>	52	<b>Plate #:</b>	127
<b>Object Type:</b>	Inlay		
<b>Collection:</b>	Musée du Louvre	<b>Collection #:</b>	AO 328
<b>Period:</b>	Early Dynastic IIIA or IIIB	<b>Height x Width (centimeters):</b>	5.6 (Height)
<b>Ruler:</b>			
<b>Provenance:</b>	Excavation	<b>Material:</b>	Mother of Pearl
<b>Site:</b>	Telloh (Girsu)	<b>Excavator:</b>	de Sarzec
<b>Find number:</b>			
<b>Area:</b>			
<b>Remarks:</b>			

**Bibliography:** Heuzey 1902:400  
Parrot 1948:114, Fig. 27m  
de Sarzec and Heuzey 1884-1912:271-272, Fig. C

<b>Catalog #:</b>	53	<b>Plate #:</b>	128
<b>Object Type:</b>	Inlay		
<b>Collection:</b>	Musée du Louvre	<b>Collection #:</b>	AO 329 [A]
<b>Period:</b>	Early Dynastic IIIA or IIIB	<b>Height x Width (centimeters):</b>	5.8 (Height)
<b>Ruler:</b>			
<b>Provenance:</b>	Excavation	<b>Material:</b>	Mother of Pearl
<b>Site:</b>	Telloh (Girsu)	<b>Excavator:</b>	de Sarzec
<b>Find number:</b>			
<b>Area:</b>			
<b>Remarks:</b>	The original inventory number is either incorrect, or it is shared with a separate inlay. The "A" in brackets, after the Louvre inventory number, has been added by this author to avoid confusion.		
<b>Bibliography:</b>	Heuzey 1902:399 Parrot 1948:114, Fig. 271 de Sarzec and Heuzey 1884-1912:271-272, Fig. A		

<b>Catalog #:</b>	54	<b>Plate #:</b>	129
<b>Object Type:</b>	Inlay		
<b>Collection:</b>	Musée du Louvre	<b>Collection #:</b>	AO 4151
<b>Period:</b>	Early Dynastic IIIA or IIIB	<b>Height x Width (centimeters):</b>	6.3 Height)
<b>Ruler:</b>			
<b>Provenance:</b>	Excavation	<b>Material:</b>	Mother of Pearl
<b>Site:</b>	Telloh (Girsu)	<b>Excavator:</b>	Cros
<b>Find number:</b>			
<b>Area:</b>			
<b>Remarks:</b>			
<b>Bibliography:</b>	Cros 1910:110 Parrot 1948:115, Fig. 27g		

<b>Catalog #:</b>	55	<b>Plate #:</b>	130
<b>Object Type:</b>	Inlay		
<b>Collection:</b>	Musée du Louvre	<b>Collection #:</b>	AO 4152
<b>Period:</b>	Early Dynastic IIIA or IIIB	<b>Height x Width (centimeters):</b>	5 (Height)
<b>Ruler:</b>			
<b>Provenance:</b>	Excavation	<b>Material:</b>	Mother of Pearl
<b>Site:</b>	Telloh (Girsu)	<b>Excavator:</b>	Cros
<b>Find number:</b>			
<b>Area:</b>			
<b>Remarks:</b>			
<b>Bibliography:</b>	Cros 1910:110 Parrot 1948:115, Fig. 27j		

<b>Catalog #:</b>	56	<b>Plate #:</b>	131
<b>Object Type:</b>	Inlay		
<b>Collection:</b>	Musée du Louvre	<b>Collection #:</b>	AO 208
<b>Period:</b>	Early Dynastic IIIA or IIIB	<b>Height x Width (centimeters):</b>	Unknown
<b>Ruler:</b>			
<b>Provenance:</b>	Excavation	<b>Material:</b>	Mother of Pearl
<b>Site:</b>	Telloh (Girsu)	<b>Excavator:</b>	Cros
<b>Find number:</b>			
<b>Area:</b>			
<b>Remarks:</b>			
<b>Bibliography:</b>	Heuzey 1902:392 Parrot 1948:112 de Sarzec and Heuzey 1884-1912:267 and Pl. 46(7)		

<b>Catalog #:</b>	57	<b>Plate #:</b>	183-185
<b>Object Type:</b>	Vessel: Votive		
<b>Collection:</b>	Musée du Louvre	<b>Collection #:</b>	AO 2674
<b>Period:</b>	Early Dynastic IIIB	<b>Height x Width (centimeters):</b>	35 (Height)
<b>Ruler:</b>	Enmetena		
<b>Provenance:</b>	Excavation	<b>Material:</b>	Silver
<b>Site:</b>	Telloh (Girsu)	<b>Excavator:</b>	de Sarzec
<b>Find number:</b>			
<b>Area:</b>	Tell K - Area and level of the "Massif of Entemena"		
<b>Remarks:</b>	Dedicated by Enmetena to Ningirsu .		

**Bibliography:**

Amiet 1980a:Fig. 335  
Barton 1929:52 (8)  
Braun-Holzinger 1991:117-118 (G11)  
Caubet and Bernus-Taylor 1991:21 (center, left)  
Christian 1940:Pl. 192  
Conteneau 1931: 601-604, Figs. 406-407  
Cooper 1986:60 (La 5.7)  
Heuzey 1900:79-80, Fig. 55  
Heuzey 1902: 372-380, Fig. 218  
Kramer 1963:316 (20)  
Moortgat 1969:Pl. 113  
Müller-Karpe:183-184, Pls. 106-107, fig. 1280  
Parrot 1948:109-110, Pl. 8a  
de Sarzec and Heuzey 1884-1912:261, 419, Pls. 43 and 43bis, ép. 57  
Sollberger 1956a:40 (Ent. 34)  
Sollberger and Kupper 1971:69 (IC7e)  
Steible 1982a:250-251 (Ent. 34)  
Thureau-Dangin 1907:34-35 (h)  
Unger 1926:86, Fig. 28  
Vigneau 1936 (Vol. 1):Pl. 209  
Ward 1910:31, Fig. 56

<b>Catalog #:</b>	58	<b>Plate #:</b>	194
<b>Object Type:</b>	Vessel: Votive		
<b>Collection:</b>	Vorderasiatisches Museum, Berlin	<b>Collection #:</b>	VA 7248
<b>Period:</b>	Early Dynastic IIIB	<b>Height x Width (centimeters):</b>	25.1 x 40 (Diameter)
<b>Ruler:</b>	Enmetena		
<b>Provenance:</b>	Art market	<b>Material:</b>	Basalt or Steatite
<b>Site:</b>	Telloh (Girsu)	<b>Excavator:</b>	None
<b>Find number:</b>			
<b>Area:</b>			
<b>Remarks:</b>	Purchased in 1913. Fragment of a vessel.		

**Bibliography:** Asher-Greve 1992:184  
Braun-Holzinger 1991:117 (G 10)  
Conteneau 1927:Fig. 108  
Christian 1940:Pl. 268  
Cooper 1986:66 (La 5.25)  
Falkenstein 1957:401  
Hansen 1975:188-189, Pl. 87a  
Moortgat 1969:Pl. 115  
Maxwell-Hyslop 1992:80, Pl. 9  
Parrot 1948:102, Pl. 21i  
Sollberger 1956a:39 (Ent. 33)  
Steible 1982a:249 (Ent. 33)  
Jakob-Rost, et. al. 1992:80, Pl. 31  
Unger 1926:84, Fig. 24  
Weber 1914-1915:36, Pls. 44-45  
Zervos 1935:99

<b>Catalog #:</b>	59	<b>Plate #:</b>	98-99
<b>Object Type:</b>	Weapon: Spearhead		
<b>Collection:</b>	Musée du Louvre	<b>Collection #:</b>	AO 2675
<b>Period:</b>	Early Dynastic IIIA	<b>Height x Width (centimeters):</b>	80 x 13.5
<b>Ruler:</b>			
<b>Provenance:</b>	Excavation	<b>Material:</b>	Bronze/Copper
<b>Site:</b>	Telloh (Girsu)	<b>Excavator:</b>	de Sarzec
<b>Find number:</b>			
<b>Area:</b>	Tell K - Area and level of the "Construction d' Urnanše" ("Maison des fruits")		
<b>Remarks:</b>	<p>Inscribed lugal-[x], lugal kiš.  Found on the pavement outside the main structure. 7.50 meters from the eastern corner and .50 meters from basin "G" at a depth of .15 meters.</p>		
<b>Bibliography:</b>	<p>Braun-Holzinger 1991:88 (MW 3)  Caubet and Bernus-Taylor 1991:19 (center, left)  Conteneau 1927:Figs. 331  Christian 1940:Pl. 210 (1)  Cooper 1986:20 (Ki 4.1)  Heuzey 1894:52-54  Heuzey 1900:25, Fig. 18  Heuzey 1902:367-372, Fig. 217  Jacobsen 1939:181 (Fn. 34)  Moortgat 1969:28, Fig. 29  Parrot 1948:74, 106, Fig. 26 f.  de Sarzec and Heuzey 1884-1912:259, 414, Pl. 5ter (1 a-c)  Solyman 1968:135, Pl. 19 (182)  Thureau-Dangin 1907:160-161 (5)</p>		

<b>Catalog #:</b>	60	<b>Plate #:</b>	86
<b>Object Type:</b>	Weapon: Dagger		
<b>Collection:</b>	Unknown (see remarks)	<b>Collection #:</b>	None
<b>Period:</b>	Early Dynastic I	<b>Height x Width (centimeters):</b>	41 (Length)
<b>Ruler:</b>			
<b>Provenance:</b>	Excavation	<b>Material:</b>	Bronze/Copper
<b>Site:</b>	Telloh (Girsu)	<b>Excavator:</b>	de Sarzec
<b>Find number:</b>			
<b>Area:</b>	Tell K - Area and level of the "Construction inférieur" ("Construction anonyme")		
<b>Remarks:</b>	Found on the pavement outside the main structure. Stolen during transportation. Inscribed dedication to Ningirsu from a priest (sanga) PN.		
<b>Bibliography:</b>	Braun-Holzinger 1991:88 (MW1), Pl. 5 Conteneau 1931: 599-560, Figs. 404 Christian 1940:Pl. 210 (3) Parrot 1948:106, fig. 26b de Sarzec and Heuzey 1884-1912:386, 414, Pl. 6ter (2), part ép. 54		

<b>Catalog #:</b>	61	<b>Plate #:</b>	189
<b>Object Type:</b>	Weapon: Dagger		
<b>Collection:</b>	Iraq Museum, Baghdad	<b>Collection #:</b>	Unknown
<b>Period:</b>	Early Dynastic IIIB	<b>Height x Width (centimeters):</b>	18 (Length)
<b>Ruler:</b>	Eannatum		
<b>Provenance:</b>	Excavation	<b>Material:</b>	Bronze
<b>Site:</b>	Lagash (al-Hiba)	<b>Excavator:</b>	Hansen
<b>Find number:</b>	3H T7 (3H 70)		
<b>Area:</b>	Area B - Bagara of Ningirsu		
<b>Remarks:</b>	Inscribed "To Ningirsu of the Bagar, [PN]" (obverse side), "[dedicated this] for the life of his master Eannatum."		
<b>Bibliography:</b>	Braun-Holzinger 1991:88 (MW 2) Cooper 1986:47 (La 3.17) Crawford 1974:32, Fig. 4 Steible 1982:179 (Ean. 66)		

<b>Catalog #:</b>	62	<b>Plate #:</b>	186-188
<b>Object Type:</b>	Weapon: Macehead		
<b>Collection:</b>	Iraq Museum, Baghdad	<b>Collection #:</b>	Unknown
<b>Period:</b>	Early Dynastic IIIB	<b>Height x Width (centimeters):</b>	17.8 (Height)
<b>Ruler:</b>	Eannatum		
<b>Provenance:</b>	Excavation	<b>Material:</b>	Gypsum
<b>Site:</b>	Lagash (al-Hiba)	<b>Excavator:</b>	Hansen
<b>Find number:</b>	3H T4; 36 69		
<b>Area:</b>	Area B - Bagara of Ningirsu		
<b>Remarks:</b>	Inscribed "DUDU". Found in level III, floor 3 (same level as dagger inscribed to Eannatum-published in: Crawford 1974: 32, Fig. 4).		
<b>Bibliography:</b>	Crawford 1974:25 (Fn. 17), Fig. 9 Hansen 1978:80-81, Pls. 26-27 Hansen 1992:208 and fig. on 209 (far right, top) Steible 1982a:366-367 (AnLag. 18)		

<b>Catalog #:</b>	63	<b>Plate #:</b>	100-101
<b>Object Type:</b>	Weapon: Macehead		
<b>Collection:</b>	Musée du Louvre	<b>Collection #:</b>	AO 2349
<b>Period:</b>	Early Dynastic IIIA	<b>Height x Width (centimeters):</b>	19 x 16 (Diameter)
<b>Ruler:</b>	Mesalim (Kish)		
<b>Provenance:</b>	Excavation	<b>Material:</b>	Limestone
<b>Site:</b>	Telloh (Girsu)	<b>Excavator:</b>	de Sarzec
<b>Find number:</b>			
<b>Area:</b>	Tell K - Area and level of the "Construction d' Urnanše" ("Maison des fruits")		
<b>Remarks:</b>	Contemporary to Lugalshaengur. Inscribed Mesalim, King of Kish... Found on the pavement outside the main structure. 11 meters from the S.W. face of the building and 1.15 meters below the surface of the lower level.		
<b>Bibliography:</b>	Barton 1929:2 (1) Braun-Holzinger 1991:44 (K 9) Caubet and Bernus-Taylor 1991:21 (bottom) Christian 1940:Pl. 260, Fig. 3 Conteneau n. d.:Pl. 1 Conteneau 1927:4355, Fig. 328 Cooper 1986:19 (Ki 3.1) Edzard 1993-1997:74 Frankfort (1935):116, Fig. 112 Hansen 1975:Pls. 78a-b Heuzey 1894:55-58, Fig. 2Pl.3 Heuzey 1900:23-24, Fig. 15 Heuzey 1902:81-82 Hrouda 1991b:330, Pl. (un-numbered) Moortgat 1969:28, Pls. 35-36 Parrot 1948:63, 72,Pl. 17b de Sarzec and Heuzey 1884-1912:223-224, Pl. I ter (2) Sollberger and Kupper 1971:40 (IA3a) Solyman 1968:43, 135-136, Pl. 32 (223-224) Steible 1982a:215-216 Strommenger 1964:Pl. 43 Wilcke 1991:278 Thureau-Dangin 1907:160-161 (2) Unger 1926:69, Fig. 1		

<b>Catalog #:</b>	64	<b>Plate #:</b>	154
<b>Object Type:</b>	Weapon: Macehead		
<b>Collection:</b>	Musée du Louvre	<b>Collection #:</b>	AO 236
<b>Period:</b>	Early Dynastic IIIA or IIIB	<b>Height x Width (centimeters):</b>	10 x 9
<b>Ruler:</b>			
<b>Provenance:</b>	Excavation	<b>Material:</b>	Stone
<b>Site:</b>	Telloh (Girsu)	<b>Excavator:</b>	de Sarzec
<b>Find number:</b>			
<b>Area:</b>	Unknown		
<b>Remarks:</b>	Mace of ur-šul-tur (Ur-dun)		

**Bibliography:** Braun-Holzinger 1991:43 (K4), Pl. 1  
Buren 1945:Pl. 168 (15-16)  
Heuzey 1902:128  
Parrot 1948:Pl 101, fig. 21g  
de Sarzec and Heuzey 1884-1912:226, Pl. 25bis (2)  
Solyman 1968:136, Pl. 39 (241)

<b>Catalog #:</b>	65	<b>Plate #:</b>	190-193
<b>Object Type:</b>	Weapon: Macehead		
<b>Collection:</b>	British Museum	<b>Collection #:</b>	BM 23287
<b>Period:</b>	Early Dynastic IIIB	<b>Height x Width (centimeters):</b>	12.7 x 11.2 (Diameter)
<b>Ruler:</b>	Enannatum I		
<b>Provenance:</b>	Art market	<b>Material:</b>	Stone
<b>Site:</b>	Telloh (Girsu)	<b>Excavator:</b>	Clandestine/Unknown
<b>Find number:</b>			
<b>Area:</b>			
<b>Remarks:</b>	Dedicated to Ningirsu of the Eninnu, for the life of Enannatum, by the workman Barakisumun.		
<b>Bibliography:</b>	Amiet 1980a:Fig. 333 Barton 1929:46 (3) Braun-Holzinger 1991:42 (K1) Cooper 1986:54 (La 4.19) Frankfort (1935):105 Pl. 2, Figs 5-8 Hall (1928):30 Pl. 3 (bottom left and bottom right) Hansen 1975:188, Pls. 86a-b Kramer 1963:313 (13) Sollberger 1956a:29 (En. I 19) Solyman 1968:136, Pls. 35-36 (231-234) Steible 1982a:190 (En. I 19) Strommenger 1964:70 Thureau-Dangin 1907:30-31 (c) Zervos 1935:120-122		

<b>Catalog #:</b>	66	<b>Plate #:</b>	134
<b>Object Type:</b>	Weapon: Macehead		
<b>Collection:</b>	Musée du Louvre	<b>Collection #:</b>	AO 237
<b>Period:</b>	Early Dynastic IIIA or IIIB	<b>Height x Width (centimeters):</b>	11 (Height)
<b>Ruler:</b>			
<b>Provenance:</b>	Excavation	<b>Material:</b>	Calcite
<b>Site:</b>	Telloh (Girsu)	<b>Excavator:</b>	de Sarzec
<b>Find number:</b>			
<b>Area:</b>	Tell K - Area and level of the "Construction d' Urnanše" ("Maison des fruits")		
<b>Remarks:</b>			
<b>Bibliography:</b>	Heuzey 1902:127 Parrot 1948:101, Fig. 21h de Sarzec and Heuzey 1884-1912:227, 25bis (3) Solyman 1968:43-44135, Pl. 31 (218)		

**Catalog #:** 67 **Plate #:** 148

**Object Type:** Seal: Impression

**Collection:** Musée du Louvre  
(ex. coll. Allotte de la Fuÿe) **Collection #:** DP 669 (Unknown)

**Period:** Early Dynastic IIIB **Height x Width  
(centimeters):** 4.0 (Height)

**Ruler:** Lugalanda (?)

**Provenance:** Art market **Material:** Clay

**Site:** Telloh (Girsu) **Excavator:** Clandestine/Unknown

**Find number:**

**Area:**

**Remarks:** Uninscribed.

**Bibliography:** Allotte de la Fuÿe 1908-1920:Pl. 168, No. DP. 669  
Boehmer 1965:3,142 (No. 13)

<b>Catalog #:</b>	68	<b>Plate #:</b>	142
<b>Object Type:</b>	Seal: Impression		
<b>Collection:</b>	Eski Sark Eserleri Müzesi, Istanbul	<b>Collection #:</b>	ES 4645
<b>Period:</b>	Early Dynastic IIB	<b>Height x Width (centimeters):</b>	4.3 (Height)
<b>Ruler:</b>	Uru'inimgina		
<b>Provenance:</b>	Art market	<b>Material:</b>	Clay
<b>Site:</b>	Telloh (Girsu)	<b>Excavator:</b>	Cros
<b>Find number:</b>			
<b>Area:</b>	Tell P - Area of the "Porte-du-diable"		
<b>Remarks:</b>	<p>Inscribed "For Ningirsu Uru'inimgina, King of Lagaš"  Originally, this appears to have been the same seal as the "Second Seal of Lugalanda" (AO 13220). The inscription was later reworked/recut.</p>		
<b>Bibliography:</b>	<p>Boehmer 1965:3,141 (No. 8), Pl. 1 (3)  Boehmer 1975:222, Pl.124f  Cooper 1986:82 (La 9.12)  Cros 1910:269  Lambert, in Amiet 1980b:214 (1098bis)  Nagel 1959:156 (7B), 167, Pl. 29 (7B)  Sollberger 1956a:61(Ukg 59)</p>		

<b>Catalog #:</b>	69	<b>Plate #:</b>	143
<b>Object Type:</b>	Seal: Impression		
<b>Collection:</b>	Musée du Louvre (ex. coll. Allotte de la Fuÿe)	<b>Collection #:</b>	AO 13 222
<b>Period:</b>	Early Dynastic IIIB	<b>Height x Width (centimeters):</b>	4.8 (Height)
<b>Ruler:</b>	Lugalanda	<b>Material:</b>	Clay
<b>Provenance:</b>	Art market	<b>Excavator:</b>	
<b>Site:</b>	Telloh (Girsu)		
<b>Find number:</b>			
<b>Area:</b>			
<b>Remarks:</b>	Inscribed "Baranamtara, wife of Lugalanda ruler of Lagaš."		

**Bibliography:**

Allotte de la Fuÿe 1907:17-19, Pl. 3 (1-5)  
Allotte de la Fuÿe 1908-1920:Pl. 7, Nos. DP 14a-d  
Amiet 1980b: Pl. 83 (1102)  
Boehmer 1965:3,141 (No. 4), Pl. 1 (1)  
Collon 1987:193, Fig. 952  
Conteneau 1931:612-613, Fig. 416  
Cooper 1986:69 (La 8.3)  
Frankfort 1939:53-54, Fig. 23  
Lambert, in Amiet 1980:215 (1102)  
Nagel 1959:156, 168 Pl. 30 (9)  
Parrot 1948:117-118, Fig. 28b  
Sollberger 1956a:47 (Lug 5)  
Sollberger and Kupper 1971:78 (IC10c)  
Vigneau 1936 (Vol. 2):72, Fig. 37

<b>Catalog #:</b>	70	<b>Plate #:</b>	144
<b>Object Type:</b>	Seal: Impression		
<b>Collection:</b>	Musée du Louvre (ex. coll. Allotte de la Fuÿe)	<b>Collection #:</b>	AO 13 223-13 226
<b>Period:</b>	Early Dynastic IIIB	<b>Height x Width (centimeters):</b>	4.3 (Height)
<b>Ruler:</b>	Lugalanda	<b>Material:</b>	Clay
<b>Provenance:</b>	Art market	<b>Excavator:</b>	
<b>Site:</b>	Telloh (Girsu)		
<b>Find number:</b>			
<b>Area:</b>			
<b>Remarks:</b>	<p>Inscribed "Eniggal, scribe of the woman's organization"  Later impressions show that this seal was subsequently reinscribed to read "Eniggal scribe of the goddess Ba'u". See the comments by Lambert, in Amiet 1980:215 (1103bis) and also by Sollberger 1971:78</p>		
<b>Bibliography:</b>	<p>Allotte de la Fuÿe 1908-1920:Pl. 9, Nos. DP 15-18  Amiet 1980b:Pl. 83 (1103)  Boehmer 1965:3,141 (No. 6-7)  Cooper 1986:70 (La 8.4)  Frankfort 1939:53-54, Fig. 22  Lambert, in Amiet 1980:215 (1103)  Nagel 1959:152,158 Pl. 30 (10a-b)  Parrot 1948:119, Fig. 28c  Sollberger 1956a:47 (Lug 6 - Lug 11)  Sollberger and Kupper 1971:78 (IC10d)</p>		

<b>Catalog #:</b>	71	<b>Plate #:</b>	150
<b>Object Type:</b>	Seal: Impression		
<b>Collection:</b>	Musée du Louvre (ex. coll. Allotte de la Fuÿe)	<b>Collection #:</b>	AO 13 232(?)
<b>Period:</b>	Early Dynastic IIIB	<b>Height x Width (centimeters):</b>	4.0 (Height)
<b>Ruler:</b>	Lugalanda (?)		
<b>Provenance:</b>	Art market	<b>Material:</b>	Clay
<b>Site:</b>	Telloh (Girsu)	<b>Excavator:</b>	
<b>Find number:</b>			
<b>Area:</b>			
<b>Remarks:</b>	Uninscribed		
<b>Bibliography:</b>	Allotte de la Fuÿe 1908-1920:Pl. 8, No. DP 24 Amiet 1980b:Pl. 82 (1094) Boehmer 1965:3,142 (No. 11) Parrot 1948:119, Fig. 28d		

<b>Catalog #:</b>	72	<b>Plate #:</b>	140
<b>Object Type:</b>	Seal: Impression		
<b>Collection:</b>	Musée du Louvre (ex. coll. Allotte de la Fuÿe)	<b>Collection #:</b>	AO 13 220
<b>Period:</b>	Early Dynastic IIIB	<b>Height x Width (centimeters):</b>	4.3 (Height)
<b>Ruler:</b>	Lugalanda		
<b>Provenance:</b>	Art market	<b>Material:</b>	Clay
<b>Site:</b>	Telloh (Girsu)	<b>Excavator:</b>	
<b>Find number:</b>			
<b>Area:</b>			
<b>Remarks:</b>	<p>Inscribed "Lugalanda-nuḥunga, ruler of Lagaš."  Known as the "Second Seal of Lugalanda."  This seal appears to have later been re-inscribed/re-cut by Uru'inimgina (see Cross 1910:289-230).</p>		
<b>Bibliography:</b>	<p>Allotte de la Fuÿe 1907:15-16, Pl. 2  Allotte de la Fuÿe 1908-1920:Pl. 6, Nos. DP12a-d  Amiet 1980b:Pl. 83 (1098)  Boehmer 1965:3,141 (No. 2)  Cooper 1986:69 (La 8.1)  Frankfort 1939:53-54, Fig. 21  King 1910:Fig. 54  Lambert, in Amiet 1980:214 (1098)  Nagel 1959:155 (7A), Pl. 28 (7Aa-7Ab)  Parrot 1948:117, Fig. 28e  Sollberger 1956a:47 (Lug 2)  Sollberger and Kupper 1971:77 (IC10b)</p>		

<b>Catalog #:</b>	73	<b>Plate #:</b>	145
<b>Object Type:</b>	Seal: Impression		
<b>Collection:</b>	Musée du Louvre	<b>Collection #:</b>	AO 13870-73, AO 4667
<b>Period:</b>	Early Dynastic IIIB	<b>Height x Width (centimeters):</b>	3 (Height)
<b>Ruler:</b>	Lugalanda		
<b>Provenance:</b>	Excavation	<b>Material:</b>	Clay
<b>Site:</b>	Kish	<b>Excavator:</b>	de Genouillac
<b>Find number:</b>			
<b>Area:</b>			
<b>Remarks:</b>	Inscribed "Uremush chief commercial agent" this was probably the minister of commerce for Lagaš under Lugalanda. The excavated example (AO 4667) is from Kish. The other examples (i.e., those published by Allotte de la Fūye) were presumably purchased from the art market.		
<b>Bibliography:</b>	Amiet 1980b:Pl. 82 (1096) Allotte de la Fūye 1908-1920:Pl. 168, Nos. DP 661-667 Boehmer 1965:3,141 (No. 5), Pl. 2 Cooper 1986:70 (La 8.5) Delaporte 1923:Pl. 112 (2), No. A. 98 de Genouillac 1924-19225 (Vol. 2):22 (No. P. 102), Pl. 1 (5) Lambert, in Amiet 1980:214 (1096) Nagel 1959:152, 157-158 Pl. 31 (11)		

<b>Catalog #:</b>	74	<b>Plate #:</b>	203
<b>Object Type:</b>	Seal: Impression		
<b>Collection:</b>	Iraq Museum, Baghdad	<b>Collection #:</b>	Unknown
<b>Period:</b>	Early Dynastic IIIB	<b>Height x Width (centimeters):</b>	Unknown
<b>Ruler:</b>	Unknown		
<b>Provenance:</b>	Excavation	<b>Material:</b>	Clay
<b>Site:</b>	Lagash (al-Hiba)	<b>Excavator:</b>	Hansen
<b>Find number:</b>			
<b>Area:</b>	Area C - Administrative Building of Eannatum		
<b>Remarks:</b>			
<b>Bibliography:</b>	Hansen 1987:Pl. 9, Fig. 2		

<b>Catalog #:</b>	75	<b>Plate #:</b>	213
<b>Object Type:</b>	Seal: Impression		
<b>Collection:</b>	Iraq Museum, Baghdad	<b>Collection #:</b>	Unknown
<b>Period:</b>	Early Dynastic IIIB	<b>Height x Width (centimeters):</b>	Unknown
<b>Ruler:</b>	Unknown		
<b>Provenance:</b>	Excavation	<b>Material:</b>	Clay
<b>Site:</b>	Lagash (al-Hiba)	<b>Excavator:</b>	Hansen
<b>Find number:</b>			
<b>Area:</b>	Area C - Administrative Building of Eannatum		
<b>Remarks:</b>			
<b>Bibliography:</b>	Hansen 1987:Pl. 13, Fig. 9		

<b>Catalog #:</b>	76	<b>Plate #:</b>	214
<b>Object Type:</b>	Seal: Impression		
<b>Collection:</b>	Iraq Museum, Baghdad	<b>Collection #:</b>	Unknown
<b>Period:</b>	Early Dynastic IIB	<b>Height x Width (centimeters):</b>	Unknown
<b>Ruler:</b>	Unknown		
<b>Provenance:</b>	Excavation	<b>Material:</b>	Clay
<b>Site:</b>	Lagash (al-Hiba)	<b>Excavator:</b>	Hansen
<b>Find number:</b>			
<b>Area:</b>	Area C - Administrative Building of Eannatum		
<b>Remarks:</b>			
<b>Bibliography:</b>	Hansen 1987:Pl. 13, Fig. 10		

<b>Catalog #:</b>	77	<b>Plate #:</b>	204
<b>Object Type:</b>	Seal: Impression		
<b>Collection:</b>	Iraq Museum, Baghdad	<b>Collection #:</b>	Unknown
<b>Period:</b>	Early Dynastic IIIB	<b>Height x Width (centimeters):</b>	Unknown
<b>Ruler:</b>	Unknown		
<b>Provenance:</b>	Excavation	<b>Material:</b>	Clay
<b>Site:</b>	Lagash (al-Hiba)	<b>Excavator:</b>	Hansen
<b>Find number:</b>			
<b>Area:</b>	Area C - Administrative Building of Eannatum		
<b>Remarks:</b>			
<b>Bibliography:</b>	Hansen 1987:Pl. 13, Fig. 11		

<b>Catalog #:</b>	78	<b>Plate #:</b>	205
<b>Object Type:</b>	Seal: Impression		
<b>Collection:</b>	Iraq Museum, Baghdad	<b>Collection #:</b>	Unknown
<b>Period:</b>	Early Dynastic IIIB	<b>Height x Width (centimeters):</b>	Unknown
<b>Ruler:</b>	Unknown		
<b>Provenance:</b>	Excavation	<b>Material:</b>	Clay
<b>Site:</b>	Lagash (al-Hiba)	<b>Excavator:</b>	Hansen
<b>Find number:</b>			
<b>Area:</b>	Area C - Administrative Building of Eannatum		
<b>Remarks:</b>			
<b>Bibliography:</b>	Hansen 1987:Pl. 13, Fig. 12		

<b>Catalog #:</b>	79	<b>Plate #:</b>	206
<b>Object Type:</b>	Seal: Impression		
<b>Collection:</b>	Iraq Museum, Baghdad	<b>Collection #:</b>	Unknown
<b>Period:</b>	Early Dynastic IIIB	<b>Height x Width (centimeters):</b>	Unknown
<b>Ruler:</b>	Unknown		
<b>Provenance:</b>	Excavation	<b>Material:</b>	Clay
<b>Site:</b>	Lagash (al-Hiba)	<b>Excavator:</b>	Hansen
<b>Find number:</b>			
<b>Area:</b>	Area C - Administrative Building of Eannatum		
<b>Remarks:</b>			
<b>Bibliography:</b>	Hansen 1987:Pl. 13, Fig. 13		

<b>Catalog #:</b>	80	<b>Plate #:</b>	207
<b>Object Type:</b>	Seal: Impression		
<b>Collection:</b>	Iraq Museum, Baghdad	<b>Collection #:</b>	Unknown
<b>Period:</b>	Early Dynastic IIIB	<b>Height x Width (centimeters):</b>	Unknown
<b>Ruler:</b>	Unknown		
<b>Provenance:</b>	Excavation	<b>Material:</b>	Clay
<b>Site:</b>	Lagash (al-Hiba)	<b>Excavator:</b>	Hansen
<b>Find number:</b>			
<b>Area:</b>	Area C - Administrative Building of Eannatum		
<b>Remarks:</b>			
<b>Bibliography:</b>	Hansen 1987:Pl. 13, Fig. 14		

<b>Catalog #:</b>	81	<b>Plate #:</b>	208
<b>Object Type:</b>	Seal: Impression		
<b>Collection:</b>	Iraq Museum, Baghdad	<b>Collection #:</b>	Unknown
<b>Period:</b>	Early Dynastic IIIB	<b>Height x Width (centimeters):</b>	Unknown
<b>Ruler:</b>	Unknown		
<b>Provenance:</b>	Excavation	<b>Material:</b>	Clay
<b>Site:</b>	Lagash (al-Hiba)	<b>Excavator:</b>	Hansen
<b>Find number:</b>			
<b>Area:</b>	Area C - Administrative Building of Eannatum		
<b>Remarks:</b>			
<b>Bibliography:</b>	Hansen 1987:Pl. 13, Fig. 15		

<b>Catalog #:</b>	82	<b>Plate #:</b>	209
<b>Object Type:</b>	Seal: Impression		
<b>Collection:</b>	Iraq Museum, Baghdad	<b>Collection #:</b>	Unknown
<b>Period:</b>	Early Dynastic IIIB	<b>Height x Width (centimeters):</b>	Unknown
<b>Ruler:</b>	Unknown		
<b>Provenance:</b>	Excavation	<b>Material:</b>	Clay
<b>Site:</b>	Lagash (al-Hiba)	<b>Excavator:</b>	Hansen
<b>Find number:</b>			
<b>Area:</b>	Area C - Administrative Building of Eannatum		
<b>Remarks:</b>			
<b>Bibliography:</b>	Hansen 1987:Pl. 13, Fig. 16		

<b>Catalog #:</b>	83	<b>Plate #:</b>	135-136
<b>Object Type:</b>	Seal: Impression		
<b>Collection:</b>	Iraq Museum, Baghdad	<b>Collection #:</b>	Unknown
<b>Period:</b>	Early Dynastic IIIB	<b>Height x Width (centimeters):</b>	Unknown
<b>Ruler:</b>	Unknown		
<b>Provenance:</b>	Excavation	<b>Material:</b>	Clay
<b>Site:</b>	Lagash (al-Hiba)	<b>Excavator:</b>	Hansen
<b>Find number:</b>			
<b>Area:</b>	Area C - Administrative Building of Eannatum		
<b>Remarks:</b>	Seal of Eannatum		
<b>Bibliography:</b>	Hansen 1978:76-77, Fig. 8 Hansen 1987:Pl. 14, Figs. 17a-b Hansen 1992:210		

<b>Catalog #:</b>	84	<b>Plate #:</b>	147
<b>Object Type:</b>	Seal: Impression		
<b>Collection:</b>	Musée du Louvre (ex. coll. Allotte de la Fuÿe)	<b>Collection #:</b>	AO 13 876(?)
<b>Period:</b>	Early Dynastic IIIB	<b>Height x Width (centimeters):</b>	4.0 (Height)
<b>Ruler:</b>	Lugalanda (?)		
<b>Provenance:</b>	Art market	<b>Material:</b>	Clay
<b>Site:</b>	Telloh (Girsu)	<b>Excavator:</b>	Clandestine/Unknown
<b>Find number:</b>			
<b>Area:</b>			
<b>Remarks:</b>	Uninscribed.		
<b>Bibliography:</b>	Allotte de la Fuÿe 1908-1920:Pl. 168, No. DP 668 Boehmer 1965:3,142 (No. 12)		

<b>Catalog #:</b>	85	<b>Plate #:</b>	210
<b>Object Type:</b>	Seal: Impression		
<b>Collection:</b>	Iraq Museum, Baghdad	<b>Collection #:</b>	Unknown
<b>Period:</b>	Early Dynastic IIIB	<b>Height x Width (centimeters):</b>	Unknown
<b>Ruler:</b>	Unknown		
<b>Provenance:</b>	Excavation	<b>Material:</b>	Clay
<b>Site:</b>	Lagash (al-Hiba)	<b>Excavator:</b>	Hansen
<b>Find number:</b>			
<b>Area:</b>	Area C - Administrative Building of Eannatum		
<b>Remarks:</b>			
<b>Bibliography:</b>	Hansen 1987:Pl. 14, Fig. 18		

<b>Catalog #:</b>	86	<b>Plate #:</b>	137
<b>Object Type:</b>	Seal: Impression		
<b>Collection:</b>	Iraq Museum, Baghdad	<b>Collection #:</b>	Unknown
<b>Period:</b>	Early Dynastic IIIB	<b>Height x Width (centimeters):</b>	Unknown
<b>Ruler:</b>	Unknown		
<b>Provenance:</b>	Excavation	<b>Material:</b>	Clay
<b>Site:</b>	Lagash (al-Hiba)	<b>Excavator:</b>	Hansen
<b>Find number:</b>			
<b>Area:</b>	Area C - Administrative Building of Eannatum		
<b>Remarks:</b>			
<b>Bibliography:</b>	Hansen 1987:Pl. 14, Fig. 19		

<b>Catalog #:</b>	87	<b>Plate #:</b>	211
<b>Object Type:</b>	Seal: Impression		
<b>Collection:</b>	Iraq Museum, Baghdad	<b>Collection #:</b>	Unknown
<b>Period:</b>	Early Dynastic IIIB	<b>Height x Width (centimeters):</b>	Unknown
<b>Ruler:</b>	Unknown		
<b>Provenance:</b>	Excavation	<b>Material:</b>	Clay
<b>Site:</b>	Lagash (al-Hiba)	<b>Excavator:</b>	Hansen
<b>Find number:</b>			
<b>Area:</b>	Area C - Administrative Building of Eannatum		
<b>Remarks:</b>			
<b>Bibliography:</b>	Hansen 1987:Pl. 14, Fig. 20		

<b>Catalog #:</b>	88	<b>Plate #:</b>	138
<b>Object Type:</b>	Seal: Impression		
<b>Collection:</b>	Iraq Museum, Baghdad	<b>Collection #:</b>	Unknown
<b>Period:</b>	Early Dynastic IIIB	<b>Height x Width (centimeters):</b>	Unknown
<b>Ruler:</b>	Unknown		
<b>Provenance:</b>	Excavation	<b>Material:</b>	Clay
<b>Site:</b>	Lagash (al-Hiba)	<b>Excavator:</b>	Hansen
<b>Find number:</b>			
<b>Area:</b>	Area C - Administrative Building of Eannatum		
<b>Remarks:</b>			
<b>Bibliography:</b>	Hansen 1987:Pl. 14, Fig. 21		

<b>Catalog #:</b>	89	<b>Plate #:</b>	212
<b>Object Type:</b>	Seal: Impression		
<b>Collection:</b>	Iraq Museum, Baghdad	<b>Collection #:</b>	Unknown
<b>Period:</b>	Early Dynastic IIIB	<b>Height x Width (centimeters):</b>	Unknown
<b>Ruler:</b>	Unknown		
<b>Provenance:</b>	Excavation	<b>Material:</b>	Clay
<b>Site:</b>	Lagash (al-Hiba)	<b>Excavator:</b>	Hansen
<b>Find number:</b>			
<b>Area:</b>	Area C - Administrative Building of Eannatum		
<b>Remarks:</b>			
<b>Bibliography:</b>	Hansen 1987:Pl. 14, Fig. 22		

<b>Catalog #:</b>	90	<b>Plate #:</b>	141
<b>Object Type:</b>	Seal: Impression		
<b>Collection:</b>	Musée du Louvre (ex. coll. Allotte de la Fuÿe)	<b>Collection #:</b>	AO 13 221
<b>Period:</b>	Early Dynastic IIIB	<b>Height x Width (centimeters):</b>	4 (approx.)
<b>Ruler:</b>	Lugalanda		
<b>Provenance:</b>	Art market	<b>Material:</b>	Clay
<b>Site:</b>	Telloh (Girsu)	<b>Excavator:</b>	
<b>Find number:</b>			
<b>Area:</b>			
<b>Remarks:</b>	Inscribed "Lugalanda." Known as the "Third Seal of Lugalanda."		
<b>Bibliography:</b>	Allotte de la Fuÿe 1908-1920:Pl. 8, Nos.DP 13a-b Amiet 1980b:Pl. 83 (1101) Boehmer 1965:3,141 (No. 3) Nagel 1959:156 (No. 8), Pl. 29 (No. 8) Parrot 1948:117, Fig. 28g Sollberger 1956a:47 (Lug 3) Sollberger and Kupper 1971:77 (IC10b)		

<b>Catalog #:</b>	91	<b>Plate #:</b>	149
<b>Object Type:</b>	Seal: Impression		
<b>Collection:</b>	Musée du Louvre (ex. coll. Allotte de la Fuÿe)	<b>Collection #:</b>	AO 13 231(?)
<b>Period:</b>	Early Dynastic IIIB	<b>Height x Width (centimeters):</b>	4 to 4.3 (Height)
<b>Ruler:</b>	Lugalanda (?)		
<b>Provenance:</b>	Art market	<b>Material:</b>	Clay
<b>Site:</b>	Telloh (Girsu)	<b>Excavator:</b>	
<b>Find number:</b>			
<b>Area:</b>			
<b>Remarks:</b>	Uninscribed.		

**Bibliography:** Allotte de la Fuÿe 1908-1920:Pl. 8, Nos. DP 23a-b  
Amiet 1980b:Pl. 82 (1090)  
Boehmer 1965:3,142 (No. 10)  
Parrot 1948:Fig. 28h

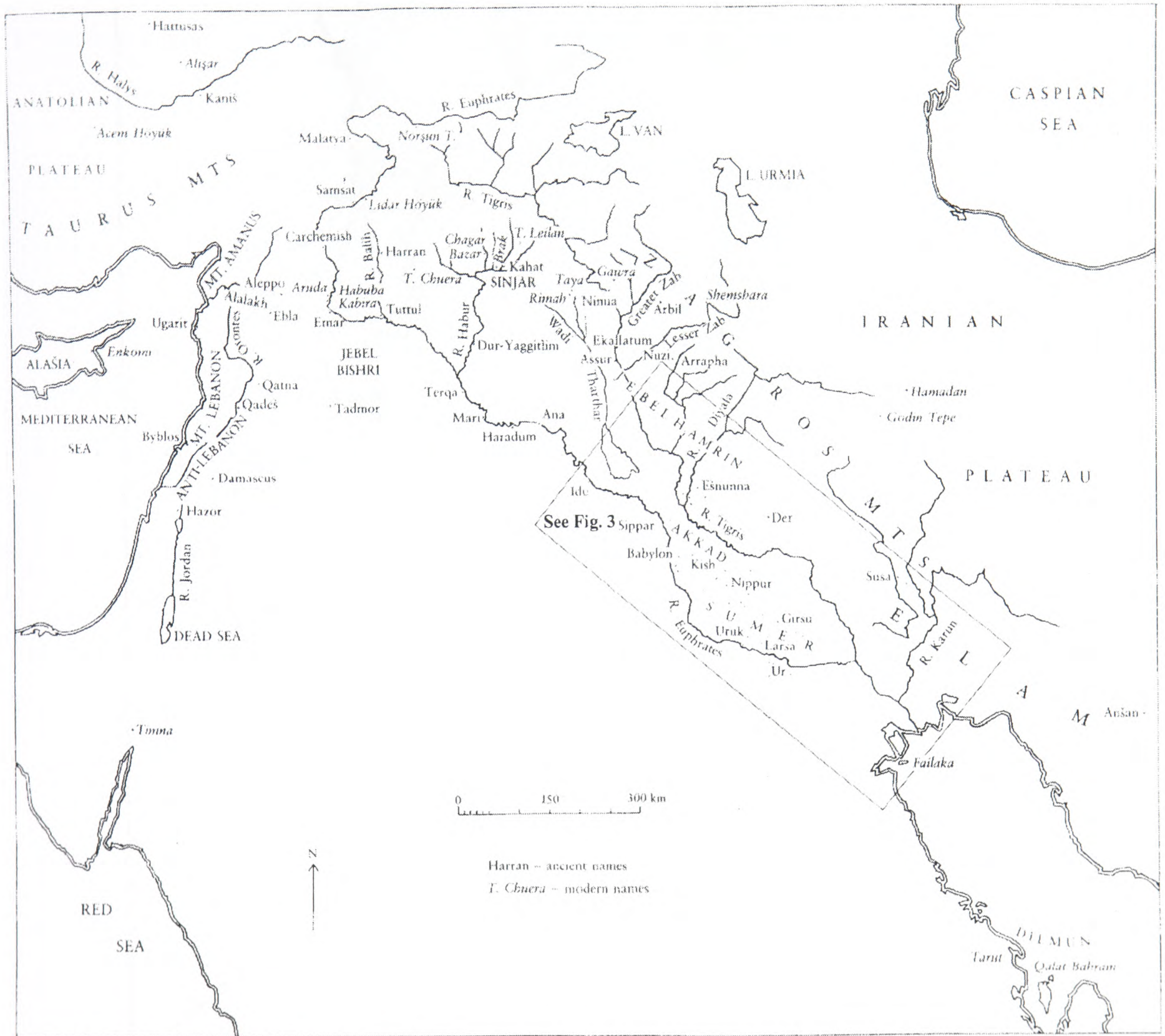
<b>Catalog #:</b>	92	<b>Plate #:</b>	139
<b>Object Type:</b>	Seal: Impression		
<b>Collection:</b>	Musée du Louvre (ex. coll. Allotte de la Fuÿe)	<b>Collection #:</b>	AO 13219
<b>Period:</b>	Early Dynastic IIIB	<b>Height x Width (centimeters):</b>	4.3 43 (Height)
<b>Ruler:</b>	Lugalanda	<b>Material:</b>	Clay
<b>Provenance:</b>	Art market	<b>Excavator:</b>	
<b>Site:</b>	Telloh (Girsu)		
<b>Find number:</b>			
<b>Area:</b>			
<b>Remarks:</b>	Inscribed "Lugalanda." From the illicit excavations of 1902? Known as the "First Seal of Lugalanda."		
<b>Bibliography:</b>	Allotte de la Fuÿe 1907:15-16, Pl. 1 Allotte de la Fuÿe 1908-1920:Pl. 5, Nos. DP 11a-e Amiet 1980b:Pl. 83 (1100) Boehmer 1965:3,141 (No. 1) Collon 1987:123-125, Fig. 526 Conteneau 1931:612, Fig. 415 Frankfort 1939:53-54, Fig. 20 King 1910:Fig. 52 Nagel 1959:154-155, 165, Pl. 27 (6) Parrot 1948:117, Fig. 28f Sollberger 1956a:47 (Lug 1) Sollberger and Kupper 1971:77 (IC10b) Vigneau 1936 (Vol. 2):72, Fig. 36		

<b>Catalog #:</b>	93	<b>Plate #:</b>	146
<b>Object Type:</b>	Seal: Impression		
<b>Collection:</b>	Musée du Louvre (ex. coll. Allotte de la Fuÿe)	<b>Collection #:</b>	AO 13 227- 13 230(?)
<b>Period:</b>	Early Dynastic IIIB	<b>Height x Width (centimeters):</b>	4.3 43 (Height)
<b>Ruler:</b>	Lugalanda (?)		
<b>Provenance:</b>	Art market	<b>Material:</b>	Clay
<b>Site:</b>	Telloh (Girsu)	<b>Excavator:</b>	
<b>Find number:</b>			
<b>Area:</b>	Tell K - Area and level of the "Construction d' Urganše" ("Maison des fruits")		
<b>Remarks:</b>	Inscribed "Gal."		
<b>Bibliography:</b>	Allotte de la Fuÿe 1908-1920:Pl. 10, Nos. DP 19-22 Amiet 1980b:Pl. 83 (1104) Boehmer 1965:3,141-142 (No. 9) Parrot 1948:119, Fig. 28a		

<b>Catalog #:</b>	94	<b>Plate #:</b>	201
<b>Object Type:</b>	Helmet		
<b>Collection:</b>	Musée du Louvre	<b>Collection #:</b>	AO 4119
<b>Period:</b>	Early Dynastic IIIA or IIIB	<b>Height x Width (centimeters):</b>	Unknown
<b>Ruler:</b>			
<b>Provenance:</b>	Excavation	<b>Material:</b>	Copper (?)
<b>Site:</b>	Telloh (Girsu)	<b>Excavator:</b>	Cros
<b>Find number:</b>			
<b>Area:</b>	Tell K - Area and level of the "Construction d' Urnanše" ("Maison des fruits")		
<b>Remarks:</b>			
<b>Bibliography:</b>	Cros 1904:16 Cros 1906:88-89 Cros 1910:43-44 Parrot 1948:106, Fig. 26 d		

<b>Catalog #:</b>	95	<b>Plate #:</b>	215
<b>Object Type:</b>	Ring		
<b>Collection:</b>	Musée du Louvre	<b>Collection #:</b>	AO 277
<b>Period:</b>	Early Dynastic IIIA or IIIB	<b>Height x Width (centimeters):</b>	2.5 (Diameter)
<b>Ruler:</b>			
<b>Provenance:</b>	Art market	<b>Material:</b>	Gold, lapis, carnelian
<b>Site:</b>	Telloh (Girsu)	<b>Excavator:</b>	Clandestine/Unknown
<b>Find number:</b>			
<b>Area:</b>			
<b>Remarks:</b>	Purchased by de Sarzec from a Turkish officer, who claimed to have purchased it from a worker.		
<b>Bibliography:</b>	Amiet 1980a:Fig. 338 Caubet and Bernus-Taylor 1991: 22 (middle, left) Conteneau 1931: 600, Fig. 405 Parrot 1948: 108, Fig. 26e de Sarzec and Heuzey 1884-1912: 391, Pl. 44ter (3a-b)		





The Ancient Near East 3200-1600 BCE

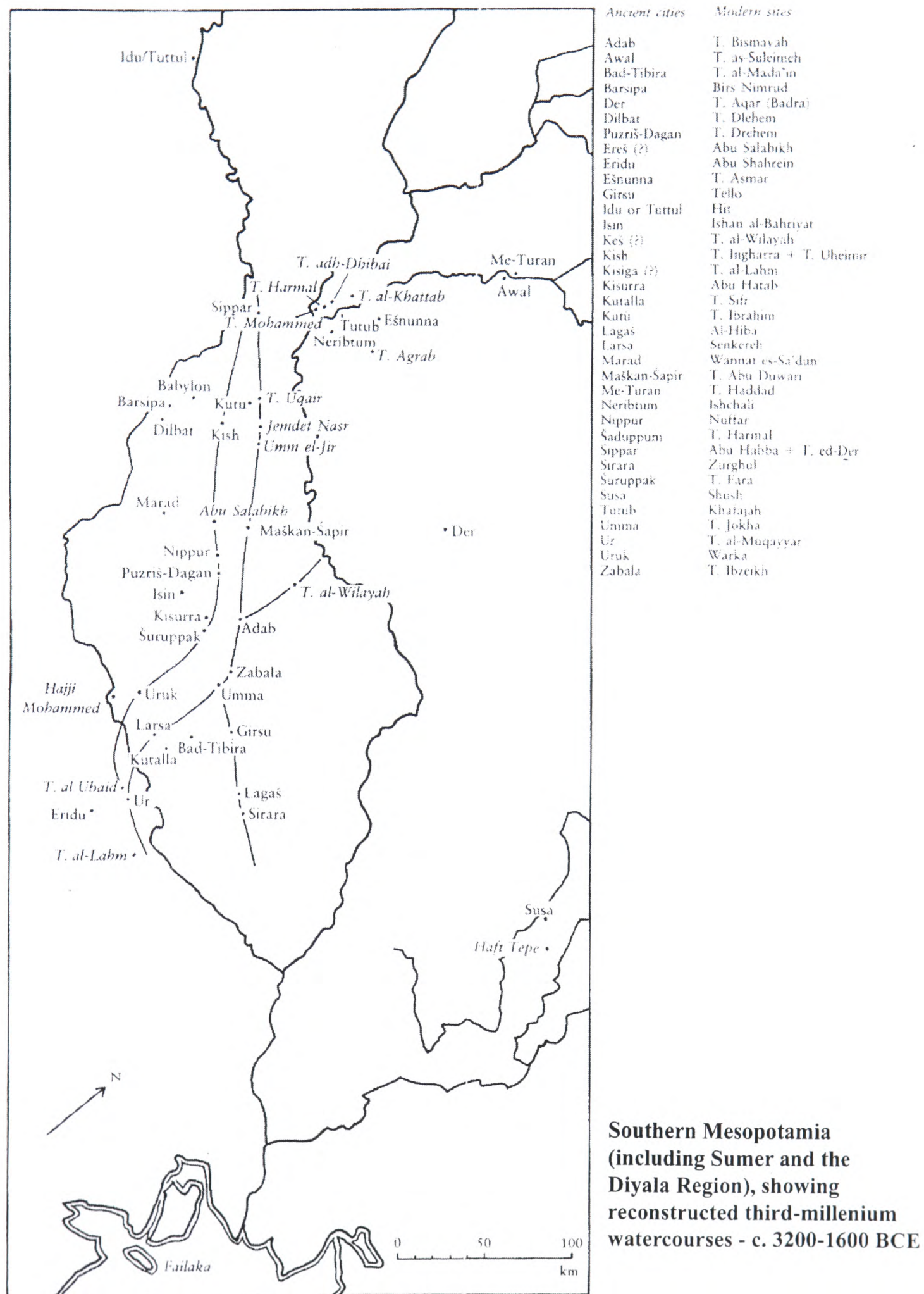
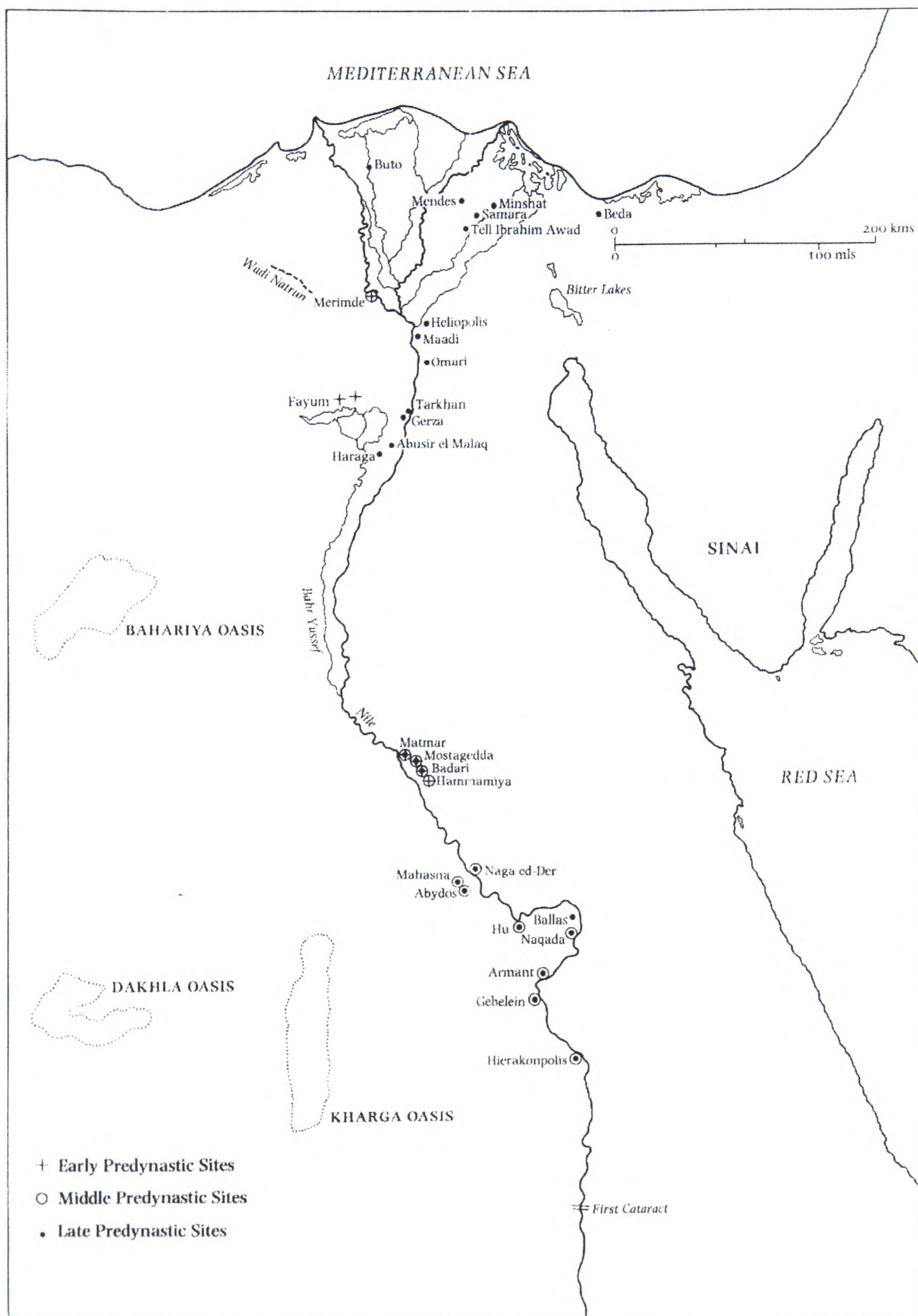
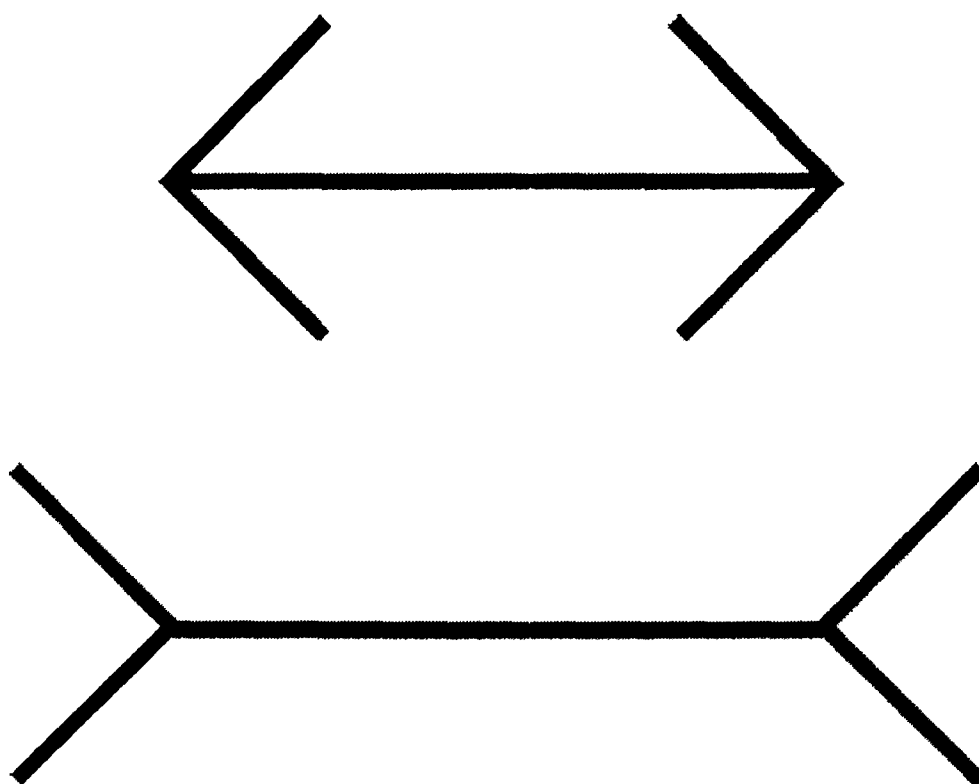


Fig. 4

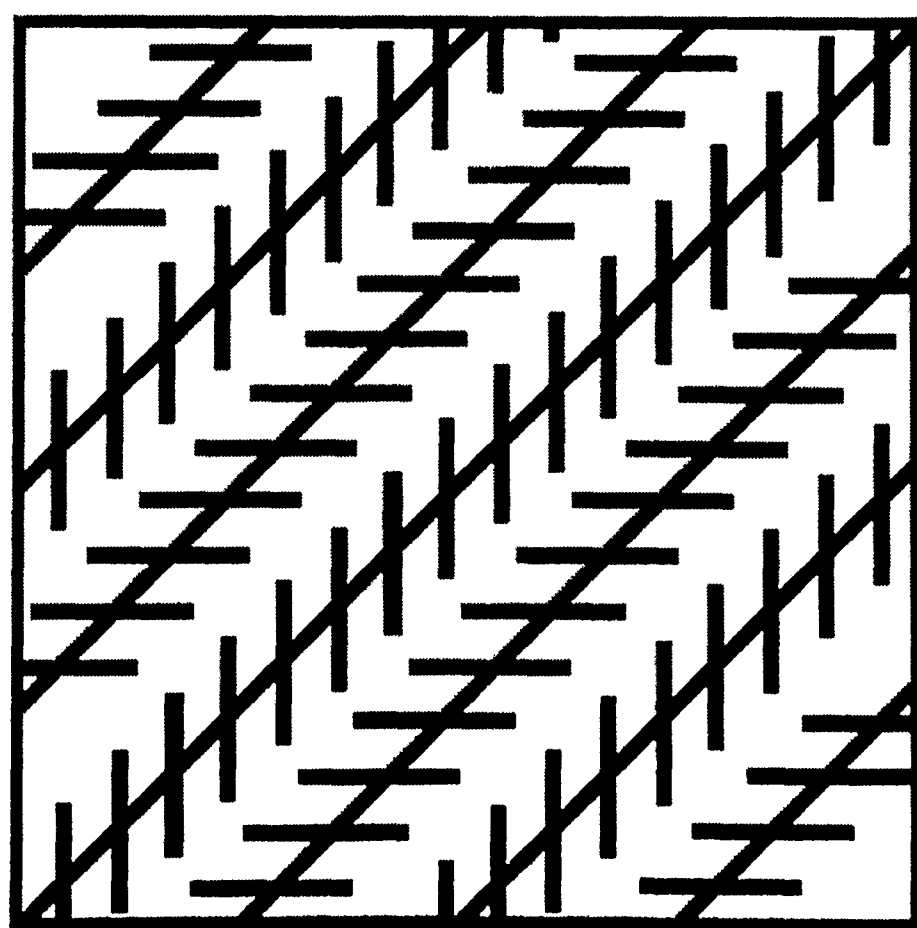


(Fig 5a)



Müller-Lyons arrows

(Fig. 5b)

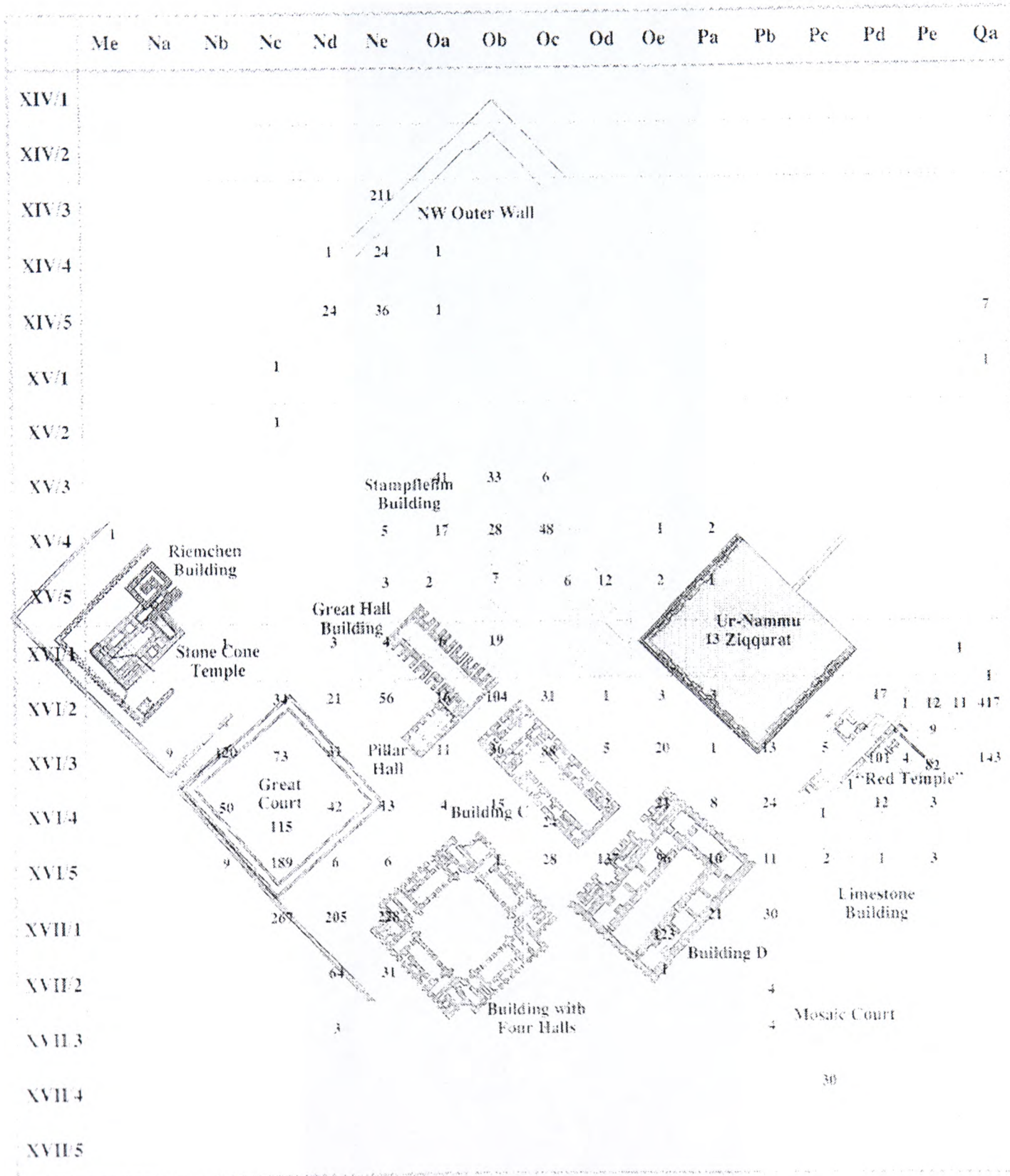


Zöllner illusion

Fig. 6



Fig. 7



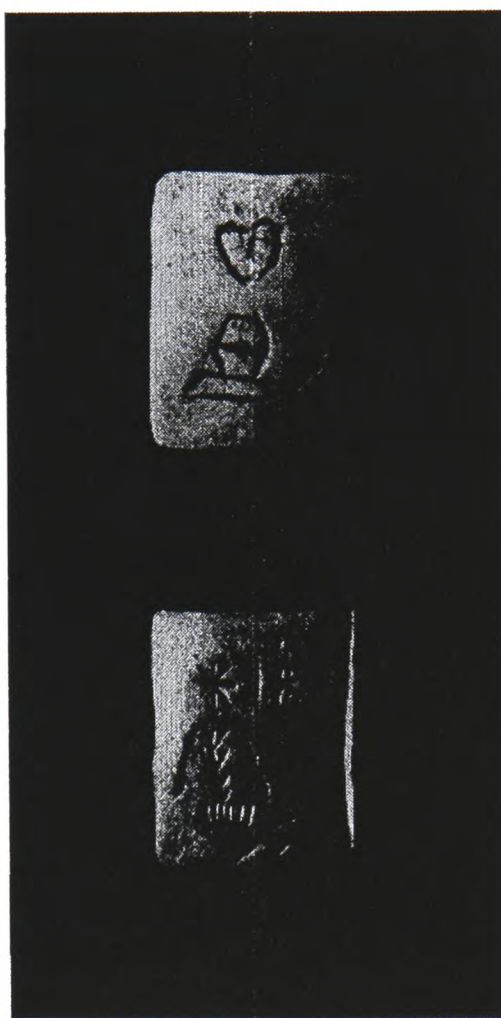


Fig. 8a



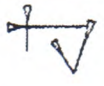








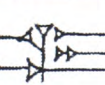



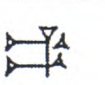











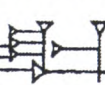



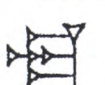







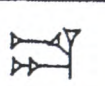


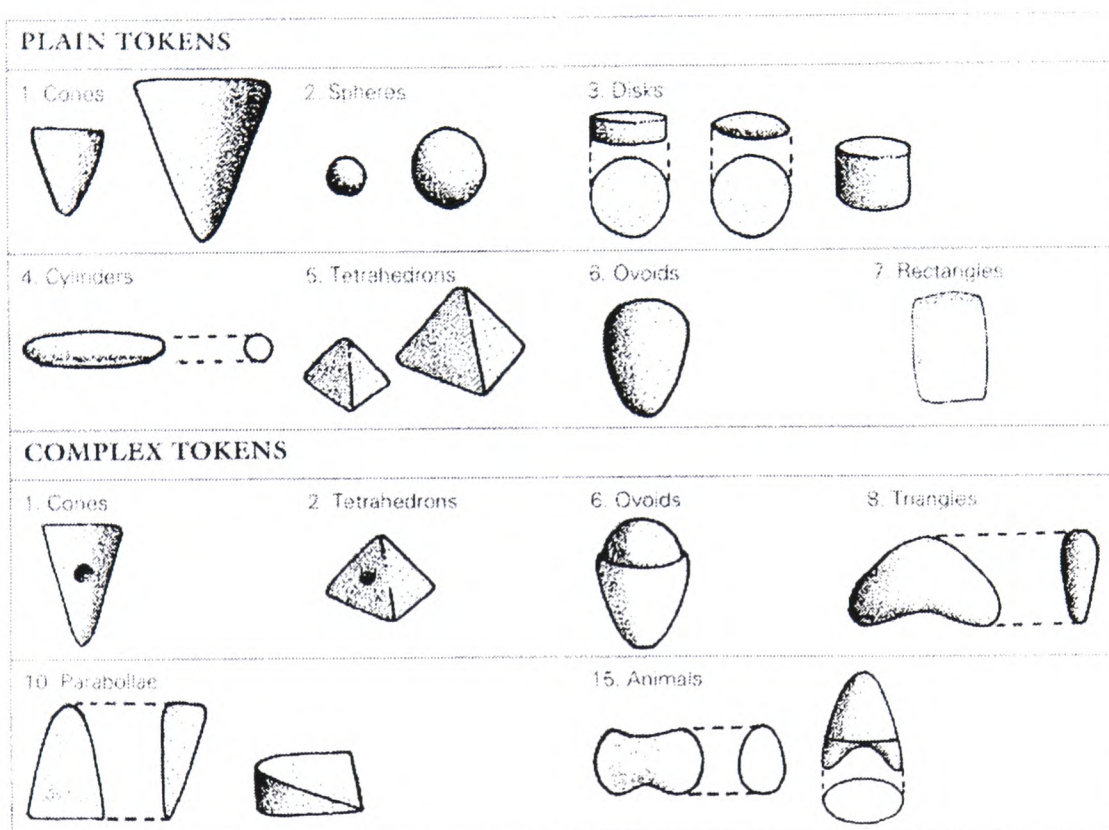
Fig. 8b

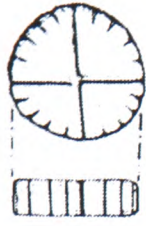

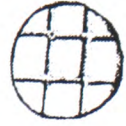



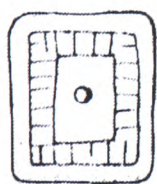









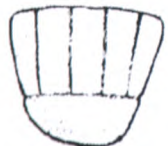

Fig. 9



WORD-SYLLABIC SYSTEMS

BIRD				
FISH				
DONKEY				
OX				
SUN				
GRAIN				
ORCHARD				
PLOUGH				
BOOMERANG				
FOOT				



<i>Token Type</i>	<i>Pictograph</i>	<i>Translation</i>
	3: 52 	type of garment or cloth <sup>153</sup>
	3: 55 	PI 385 ZATU 452a wool, fleece <sup>154</sup>
	4: 23 	ATU 508 rope
	7: 18 	ATU 589 ZATU 764 type of mat or rug
	10: 4 	ATU 390/829 ZATU 662/663 type of garment or cloth <sup>155</sup>
	10: 9 	type of garment or cloth <sup>156</sup>
	10: 12 	PI 158 type of garment or cloth <sup>157</sup>
	10: 13 	ATU 685 ZATU 644 type of garment or cloth <sup>158</sup>
	1: 34 	ATU 736 ZATU 394

**4. Types of Containers**

?

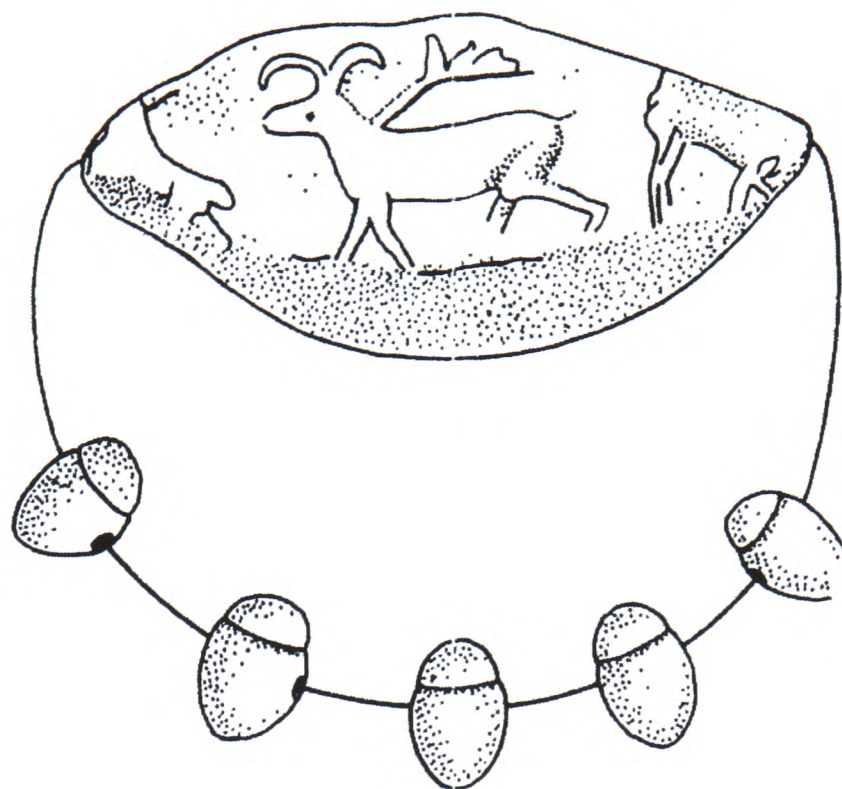


Fig 13a

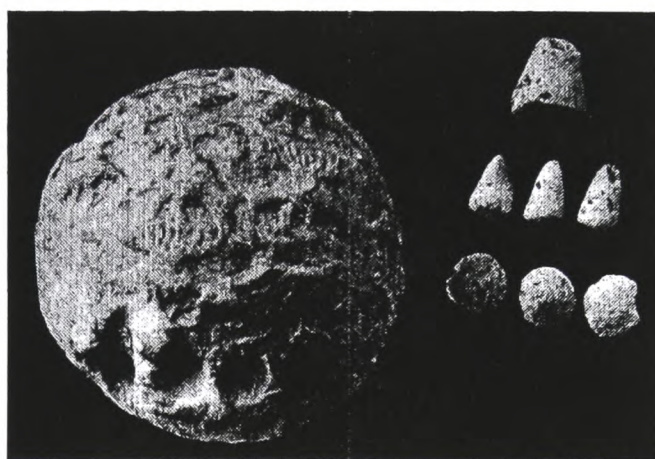


Fig 13b

Fig. 14



Fig. 15



Fig. 16

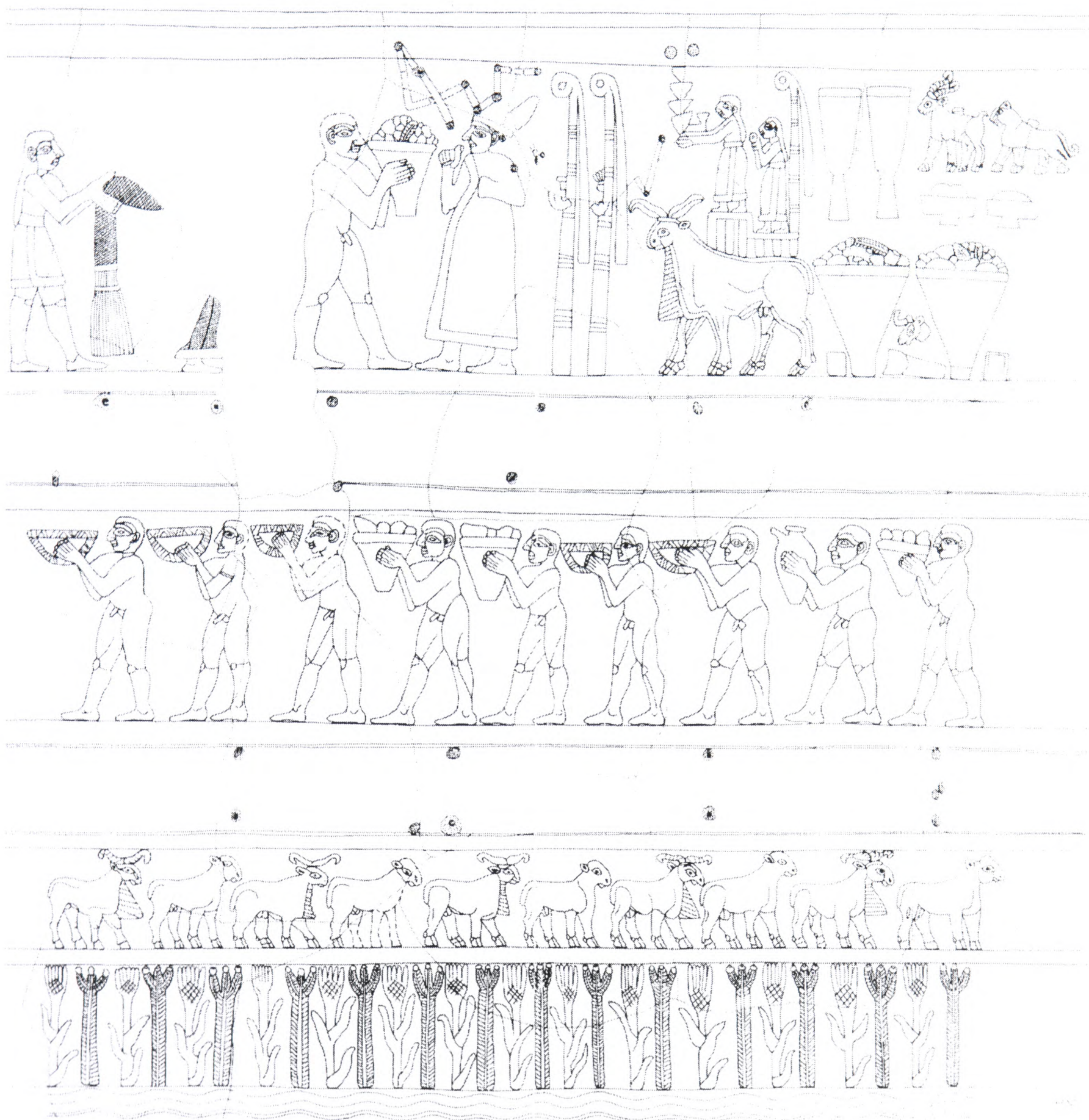


Fig. 17



Fig. 18



Fig. 19

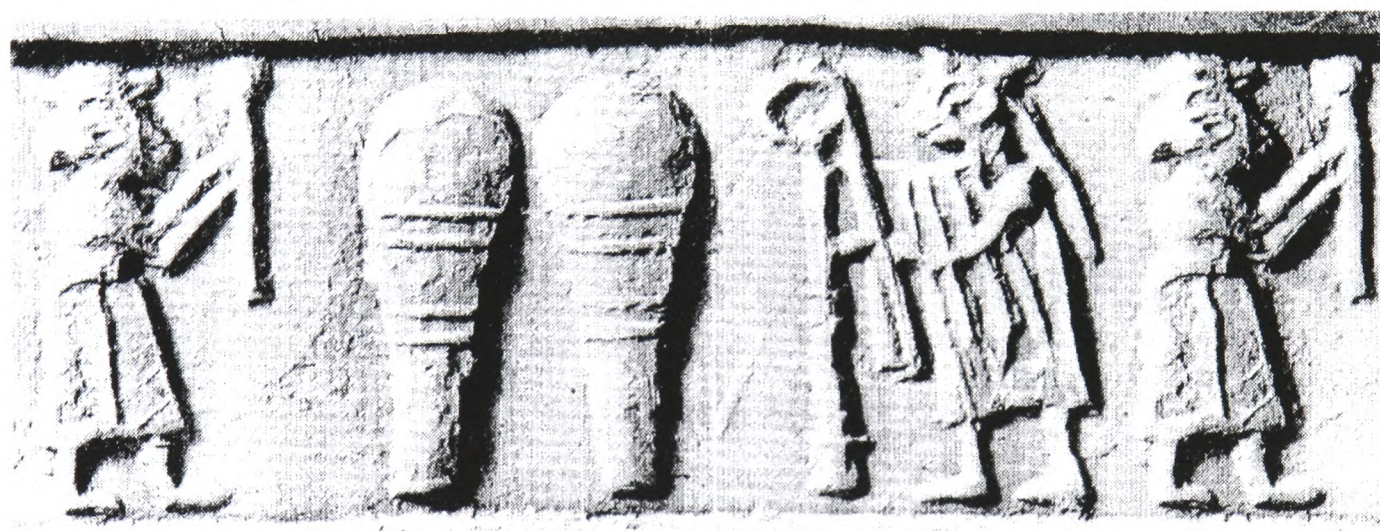


Fig. 20



Fig. 21



Fig. 22



Fig. 23



Fig. 24



Fig. 25

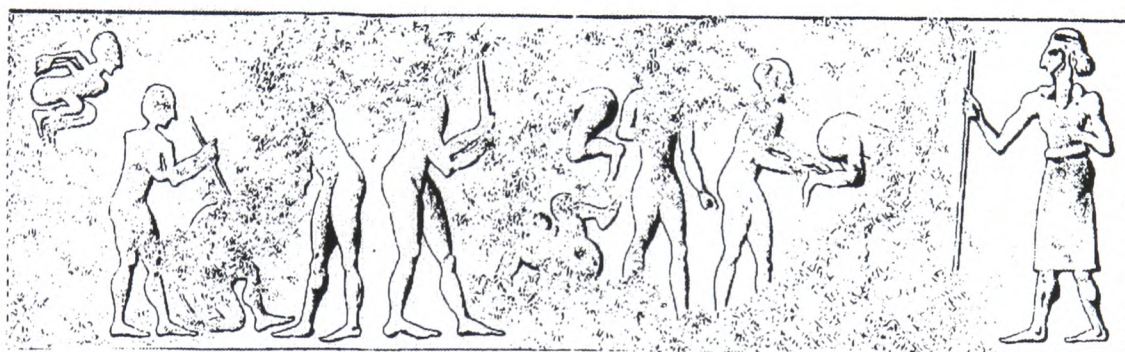


Fig. 26



Fig. 27



Fig. 28



Fig. 29



Fig. 30



Fig. 31



Fig. 32



Fig. 33



Fig. 34

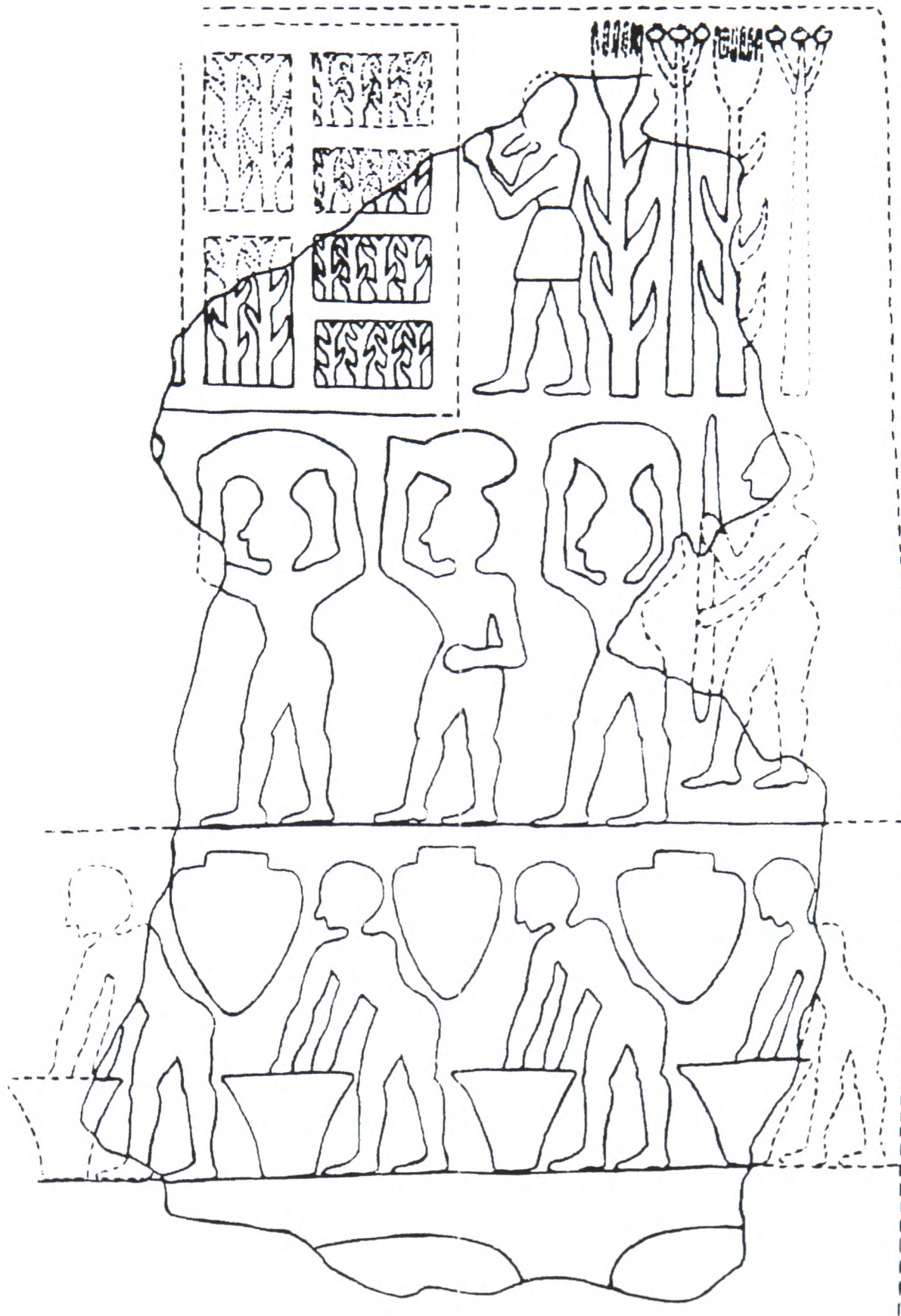


Fig. 35

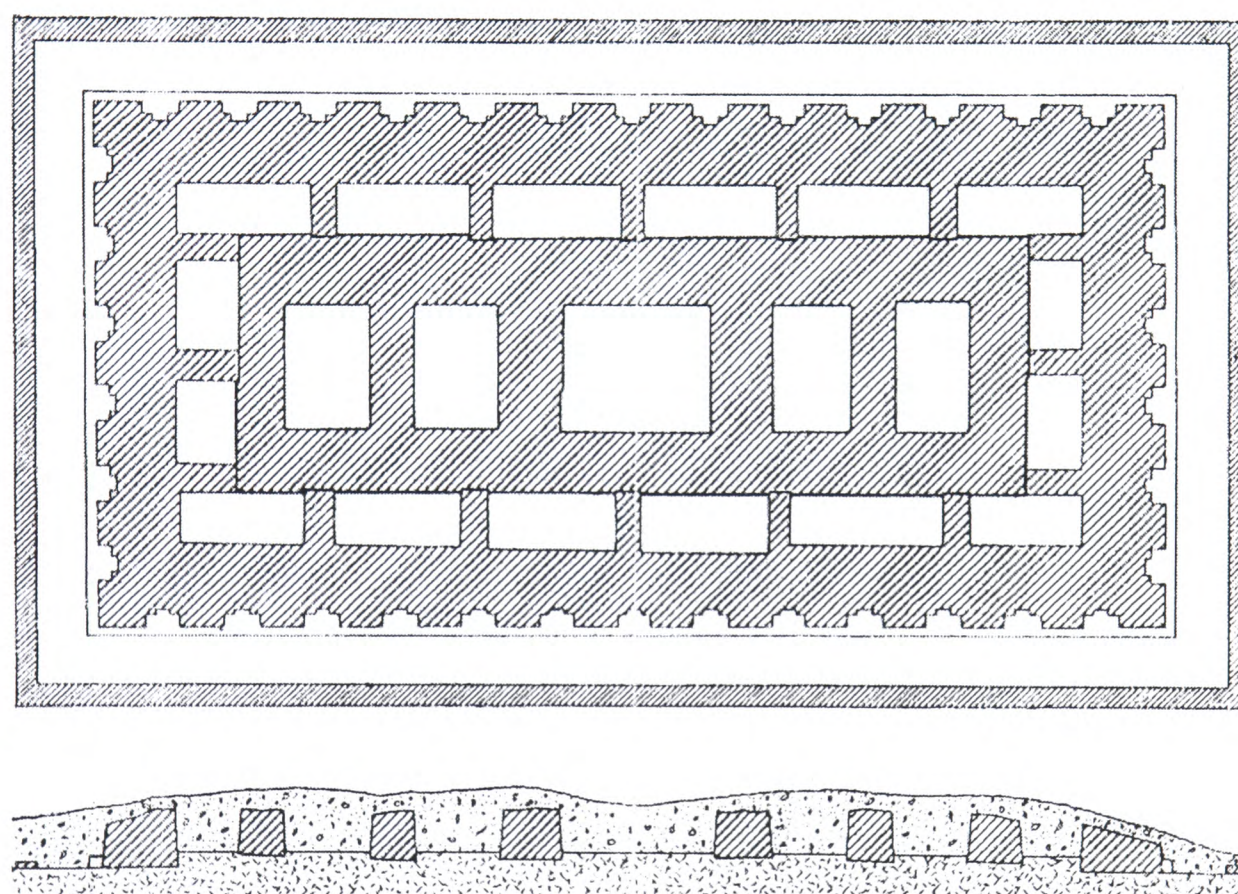


Fig. 36

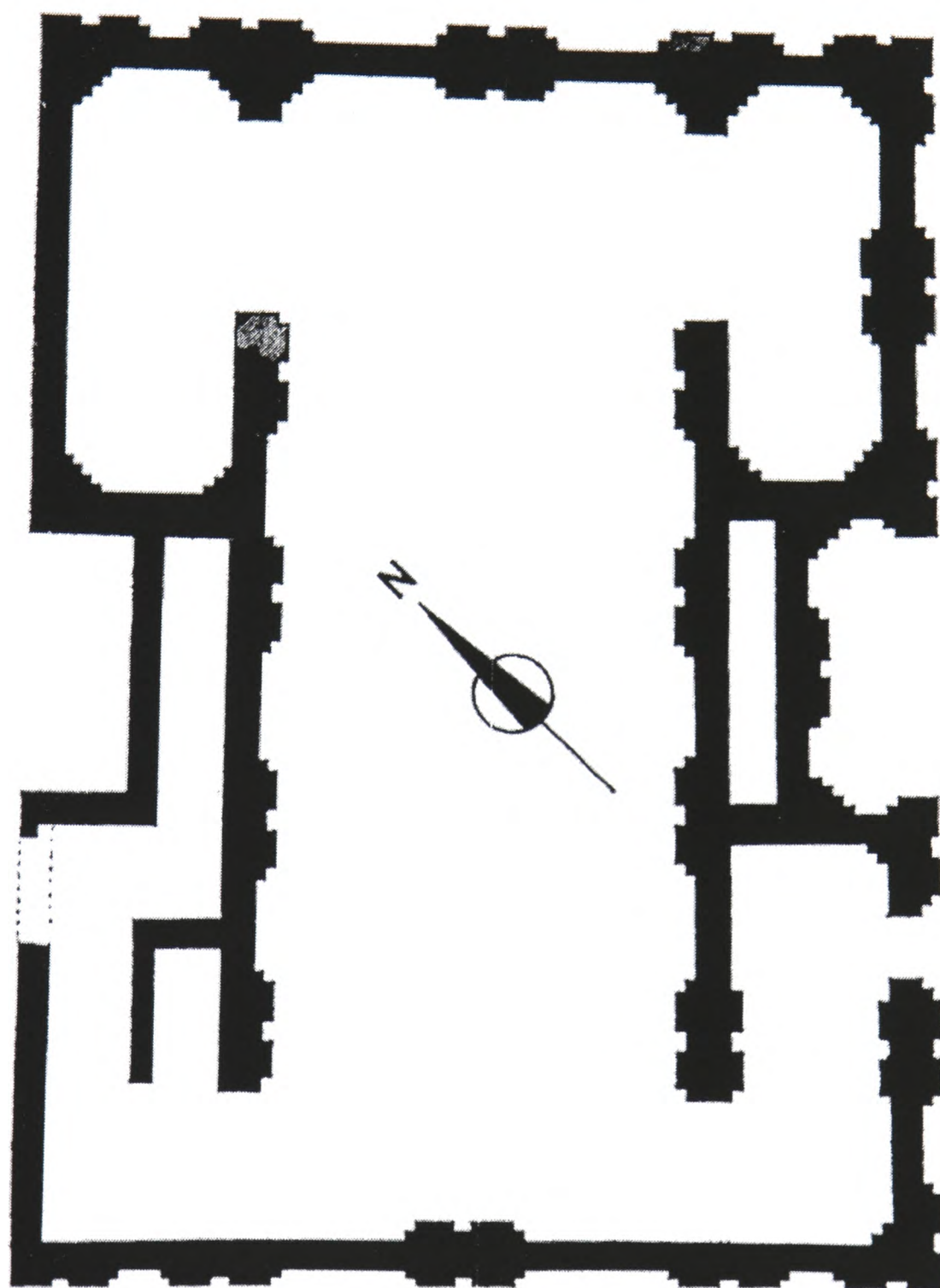


Fig. 37



Fig. 38

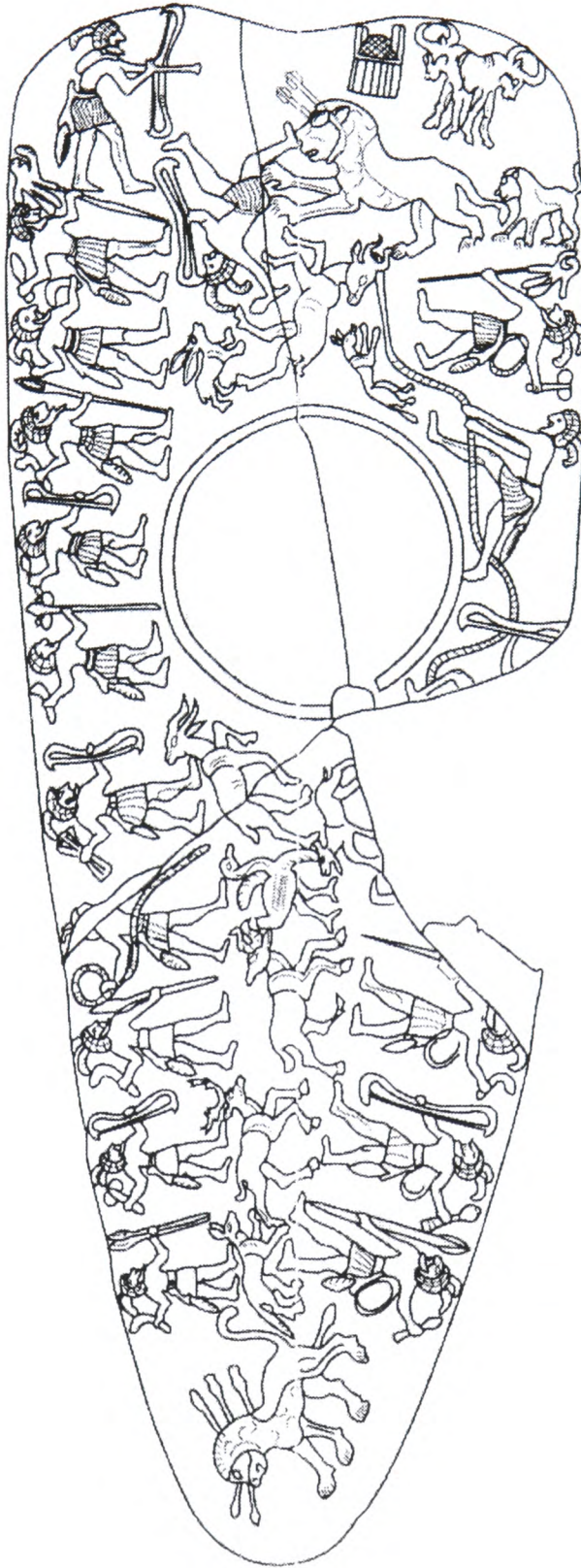


Fig. 39

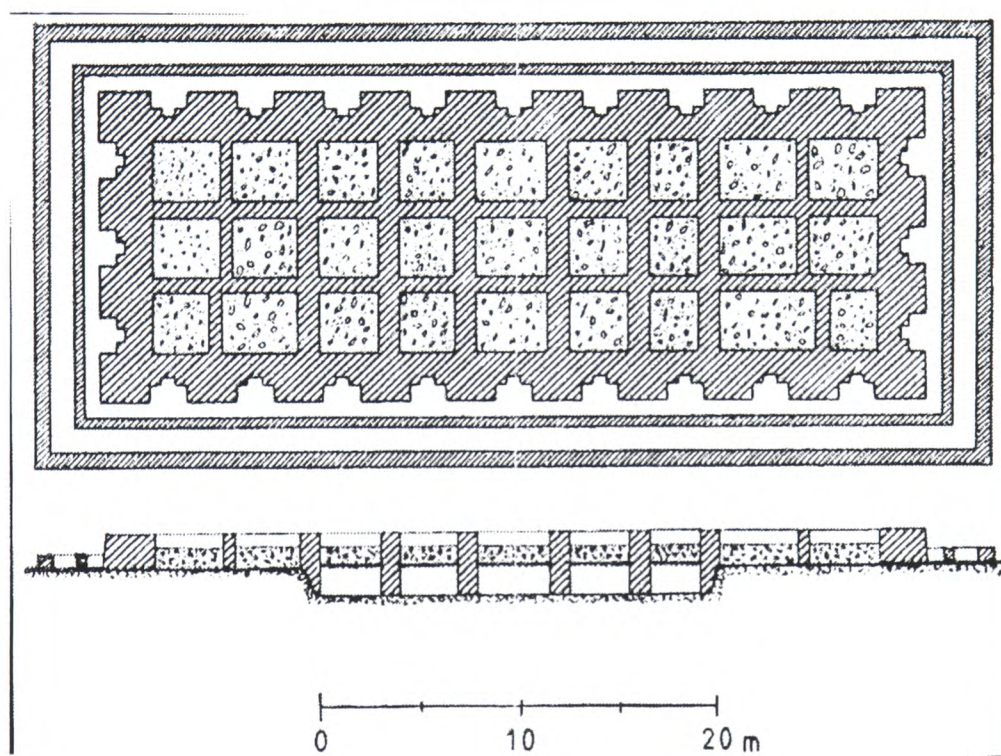
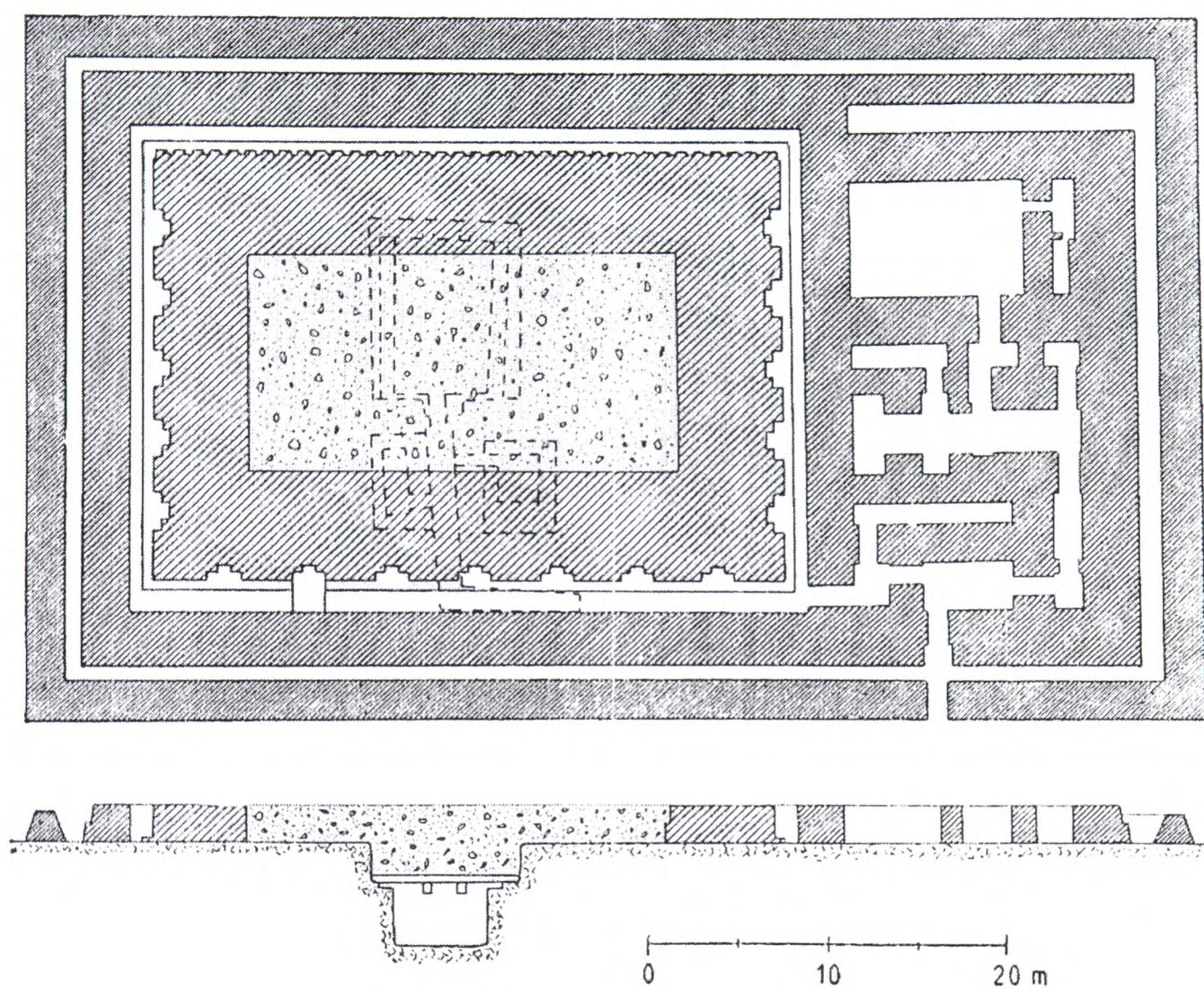
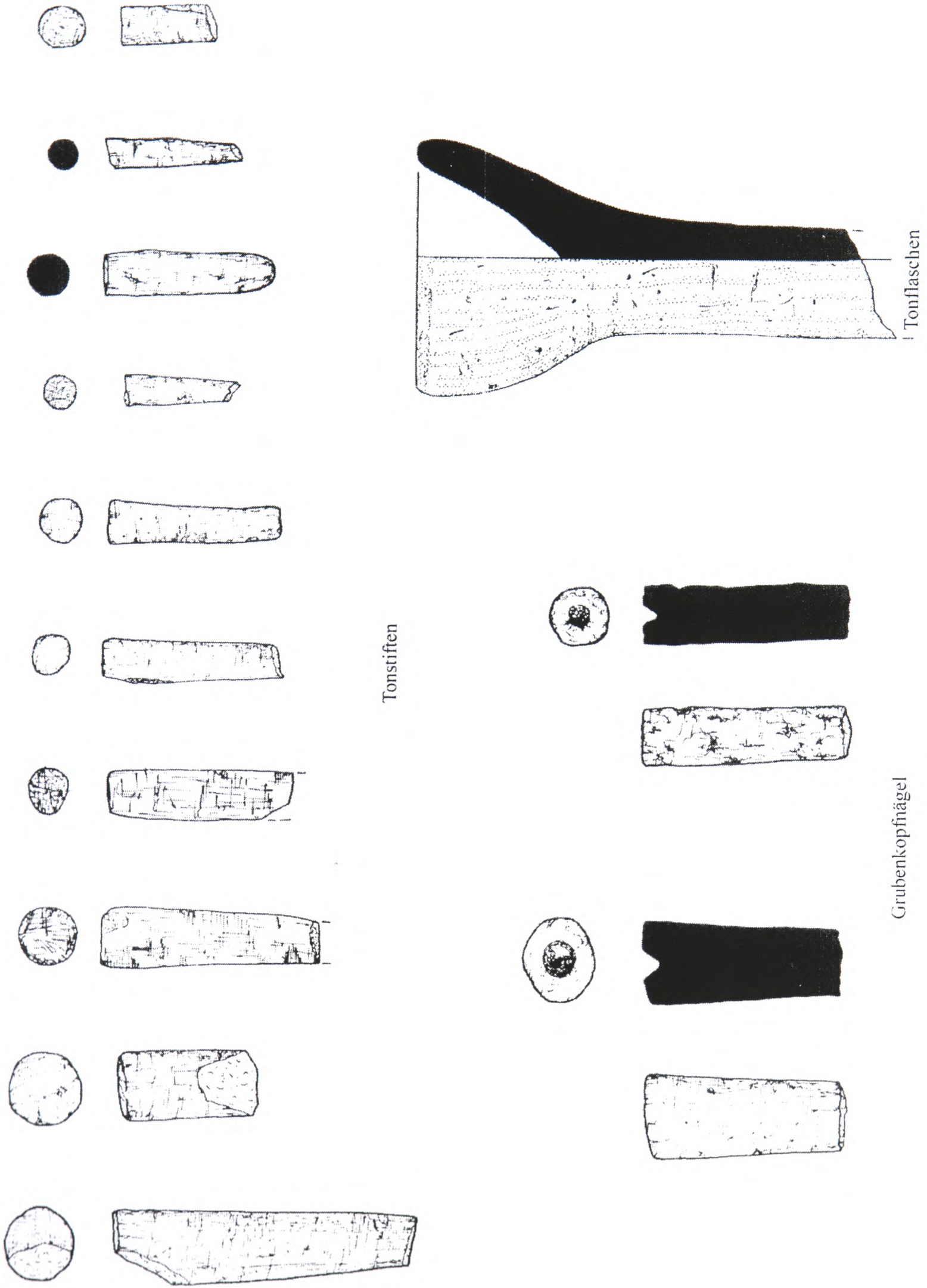


Fig. 40





Sumerian Architectural fixtures discovered at Buto.  
(Adapted from von der Way 1992:218)

Fig. 42

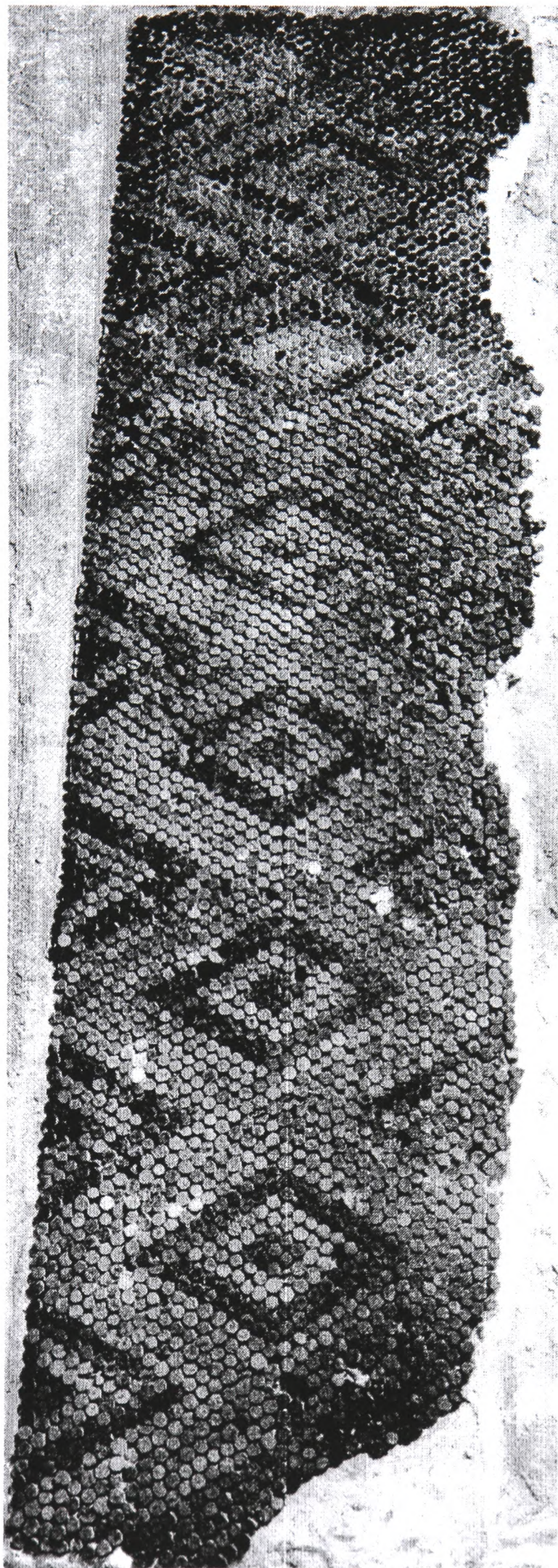


Fig. 43

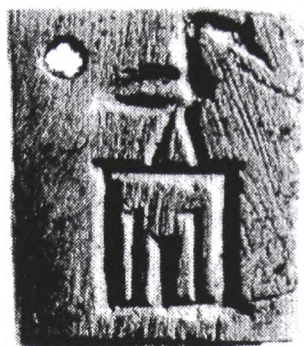
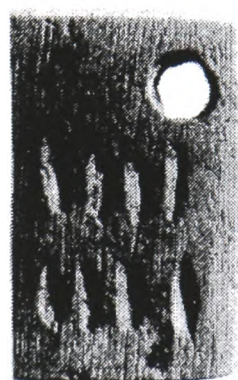
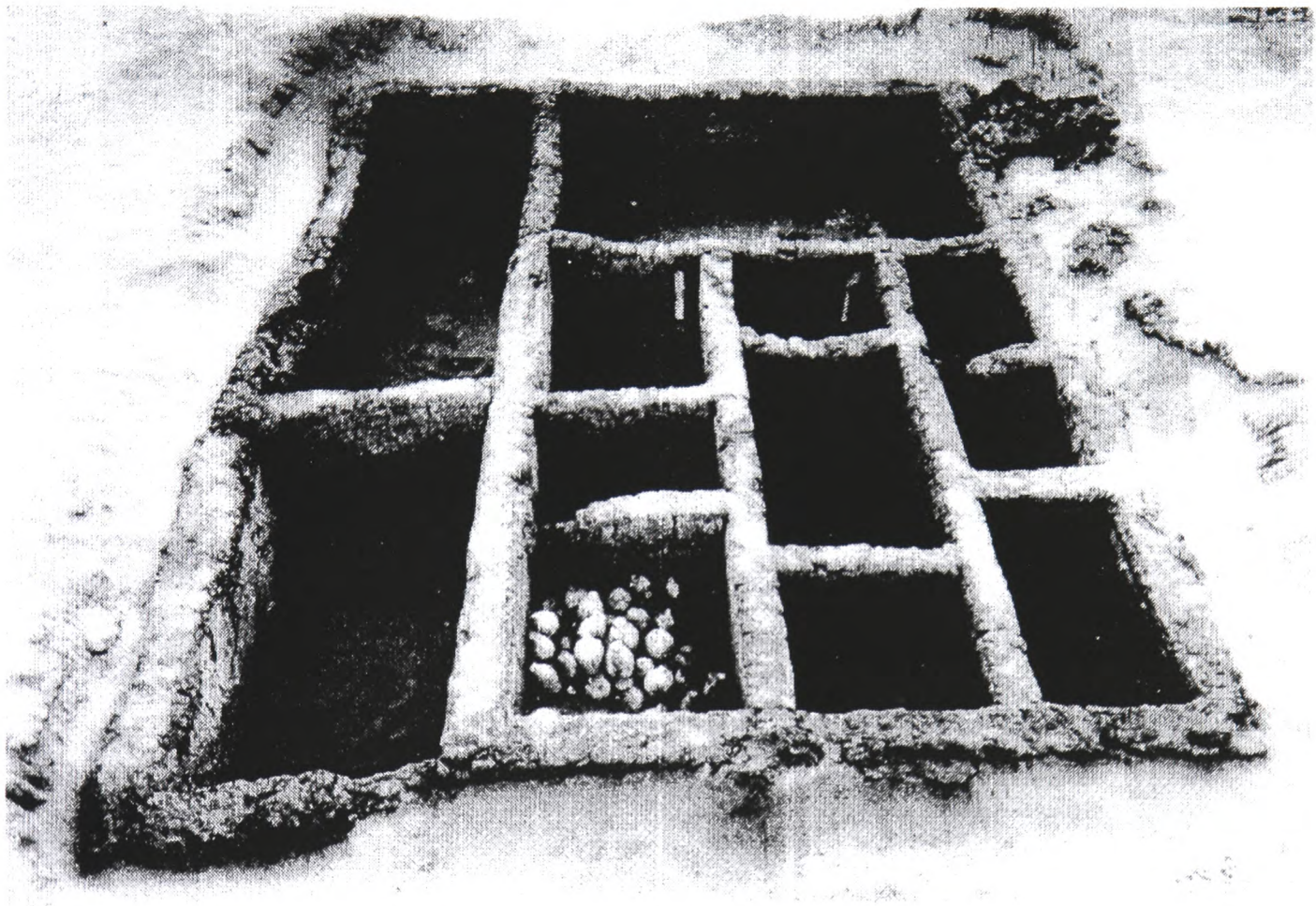


Fig. 44



Fig. 45





Tomb Uj at Abydos (Dreyer 1993:fig. 33)

Fig. 47



Fig. 48



Fig. 49



Fig. 50

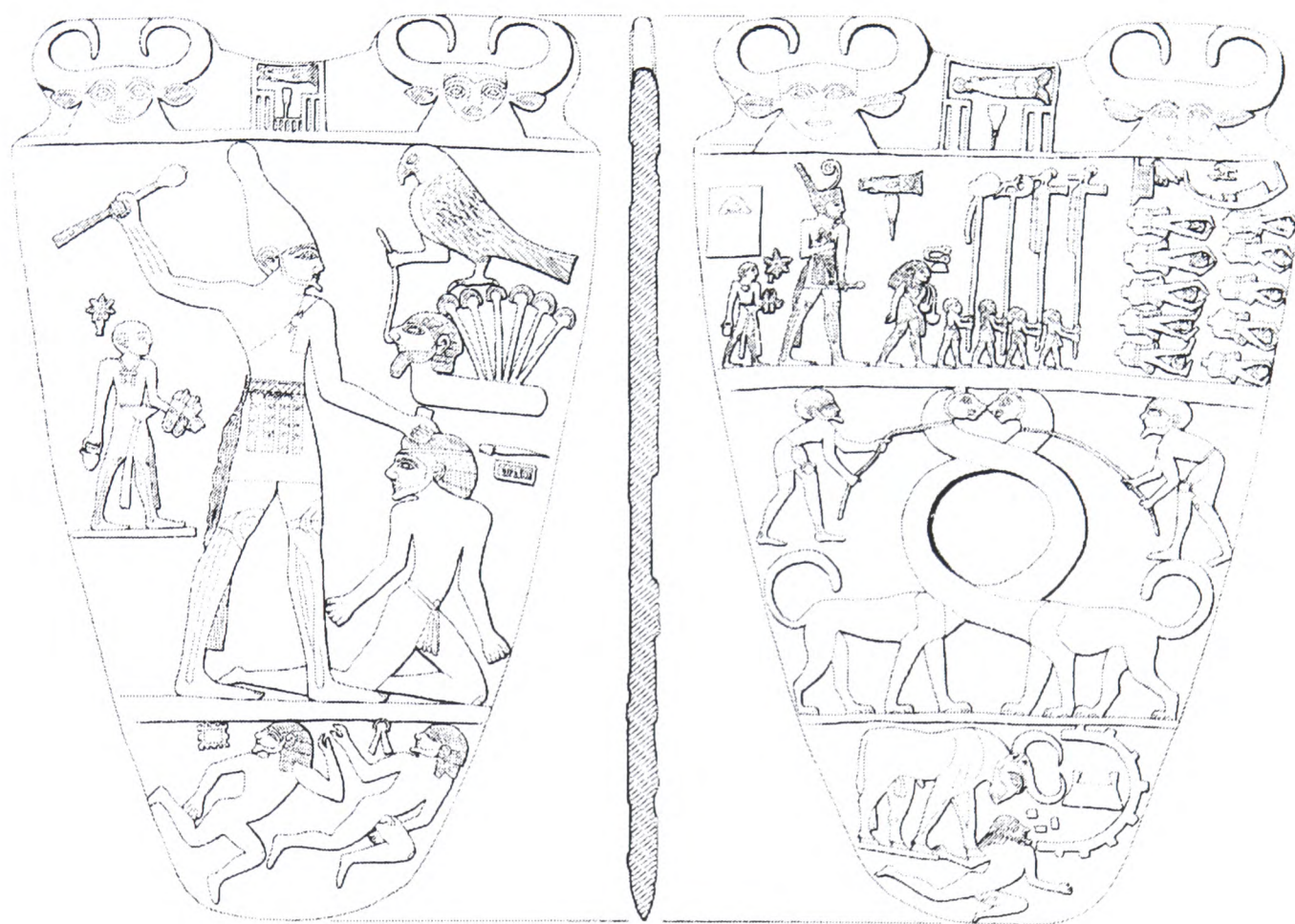


Fig. 51

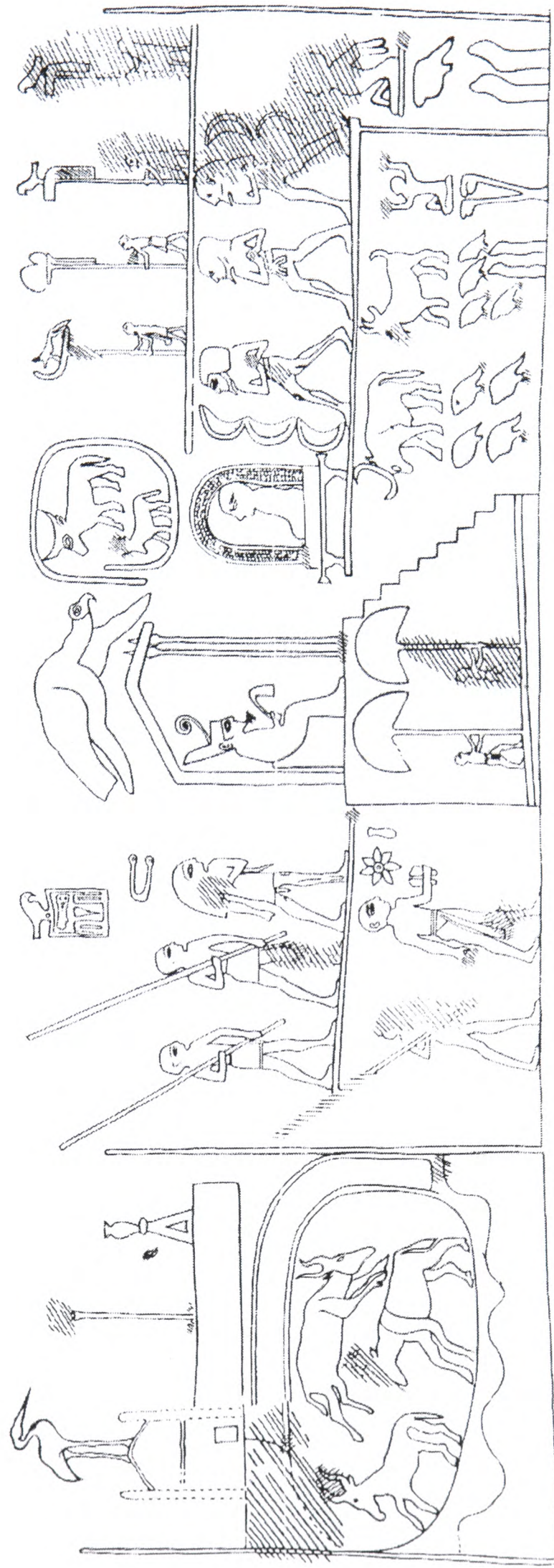
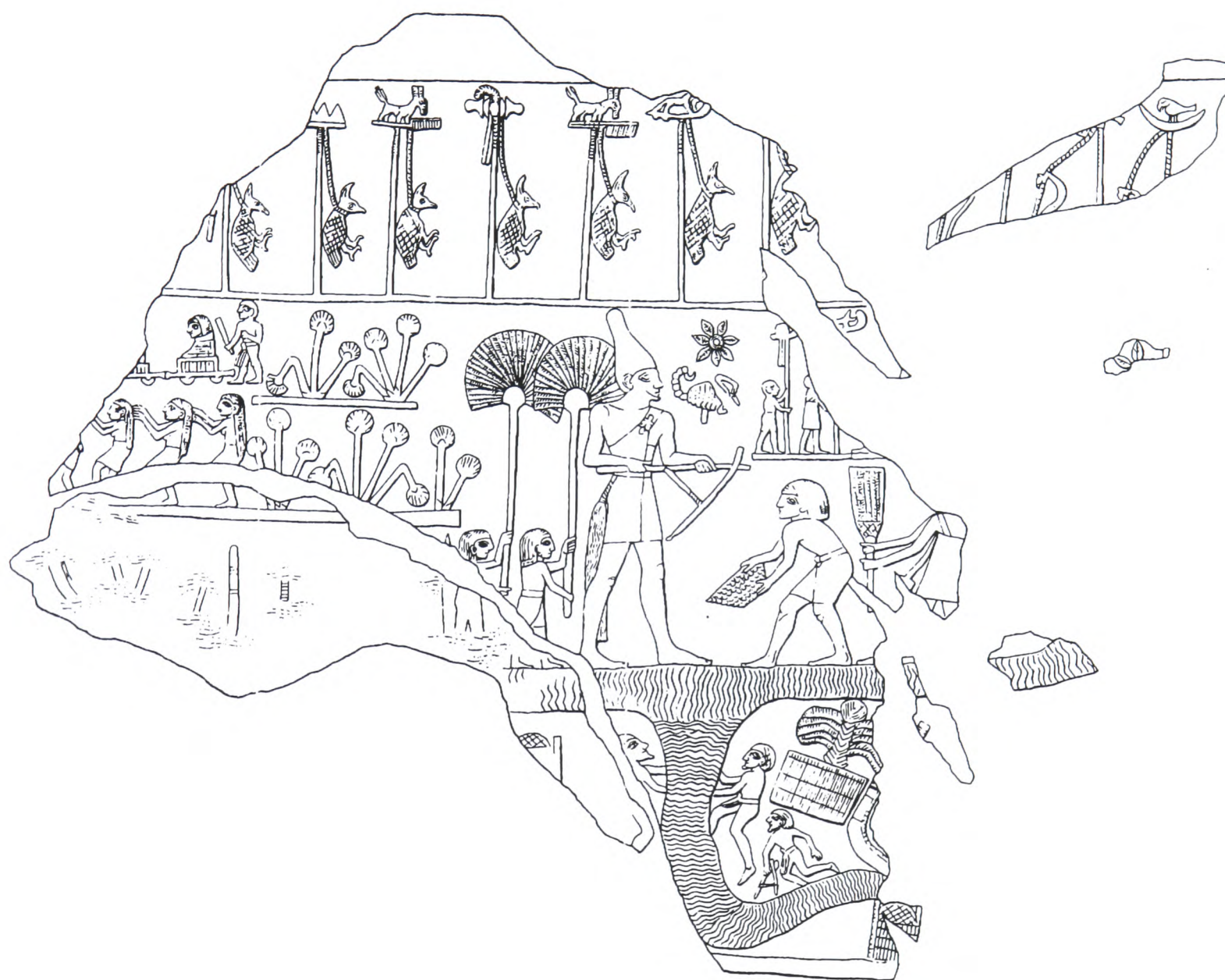


Fig. 52





The evolution of the Chinese graph for 'horse' c. 1200 BCE - 220 AD  
(Adapted from DeFrancis 1989:95-96)

	OBI graph	modern character	modern reading	meaning
1.		象	xiàng	'elephant'
2.		裘	qiú	'pelt' (mod. 裘)
3.		口	kǒu	'opening, orifice, mouth'
4.		目	mù	'eye'
5.		月	yuè	'moon, month'
6.		田	tián	'(cultivated) field'
7.		女	nǚ	'(kneeling) woman'
8.		其	qí	'(winnowing) basket' (mod. 箕)
9.		天	tiān	'overhead' > 'sky, heaven'
10.		羊	yáng	'sheep, ram'
11.		馬	mǎ	'horse'
12.		龜	guī	'turtle'
13.		魚	yú	'fish'
14.		鼎	dǐng	'tripod, cauldron'

The evolution of fourteen Chinese signs  
that were originally pictographs.  
(from DeFrancis 1981:fig.17)

Fig. 54



Fig. 55



Fig. 56

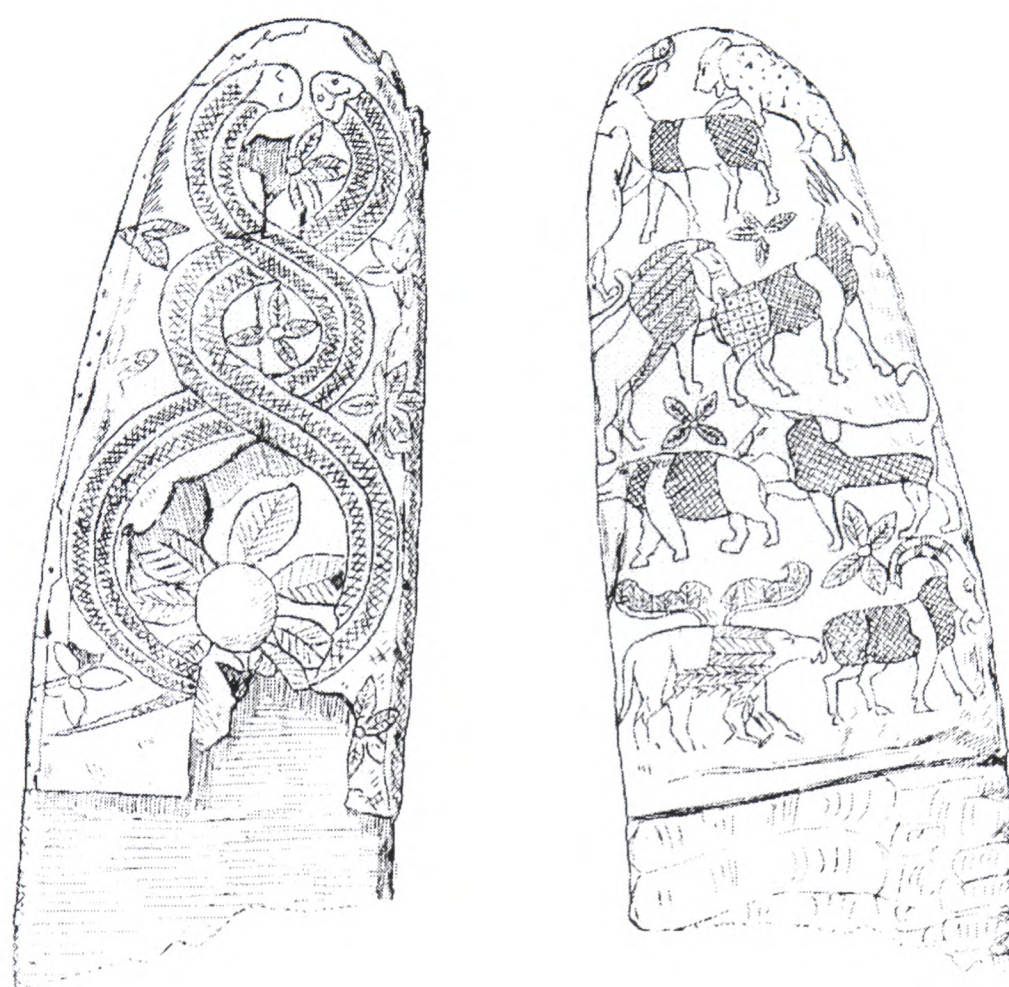


Fig. 57



Fig. 58



Fig. 59

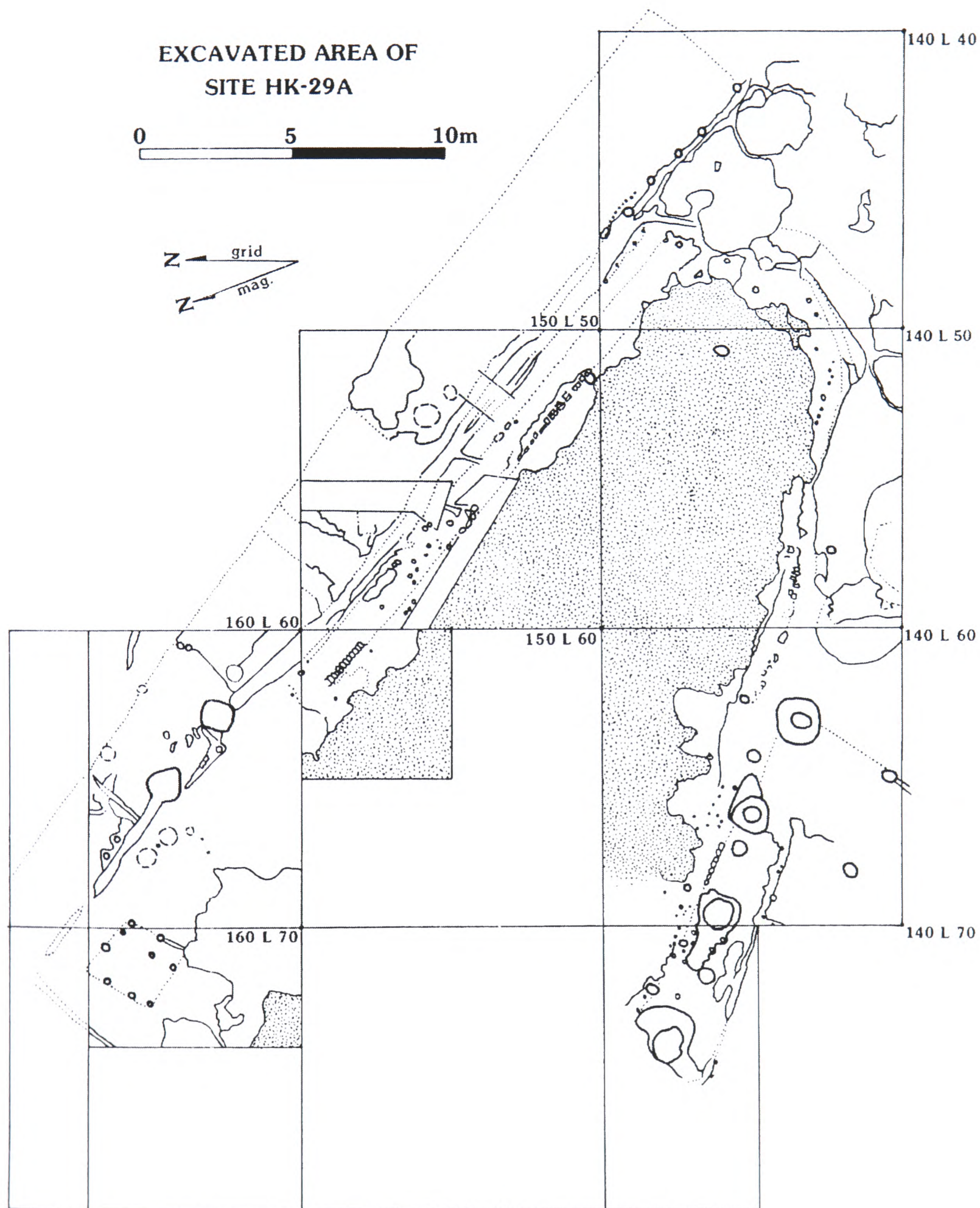


Fig. 60

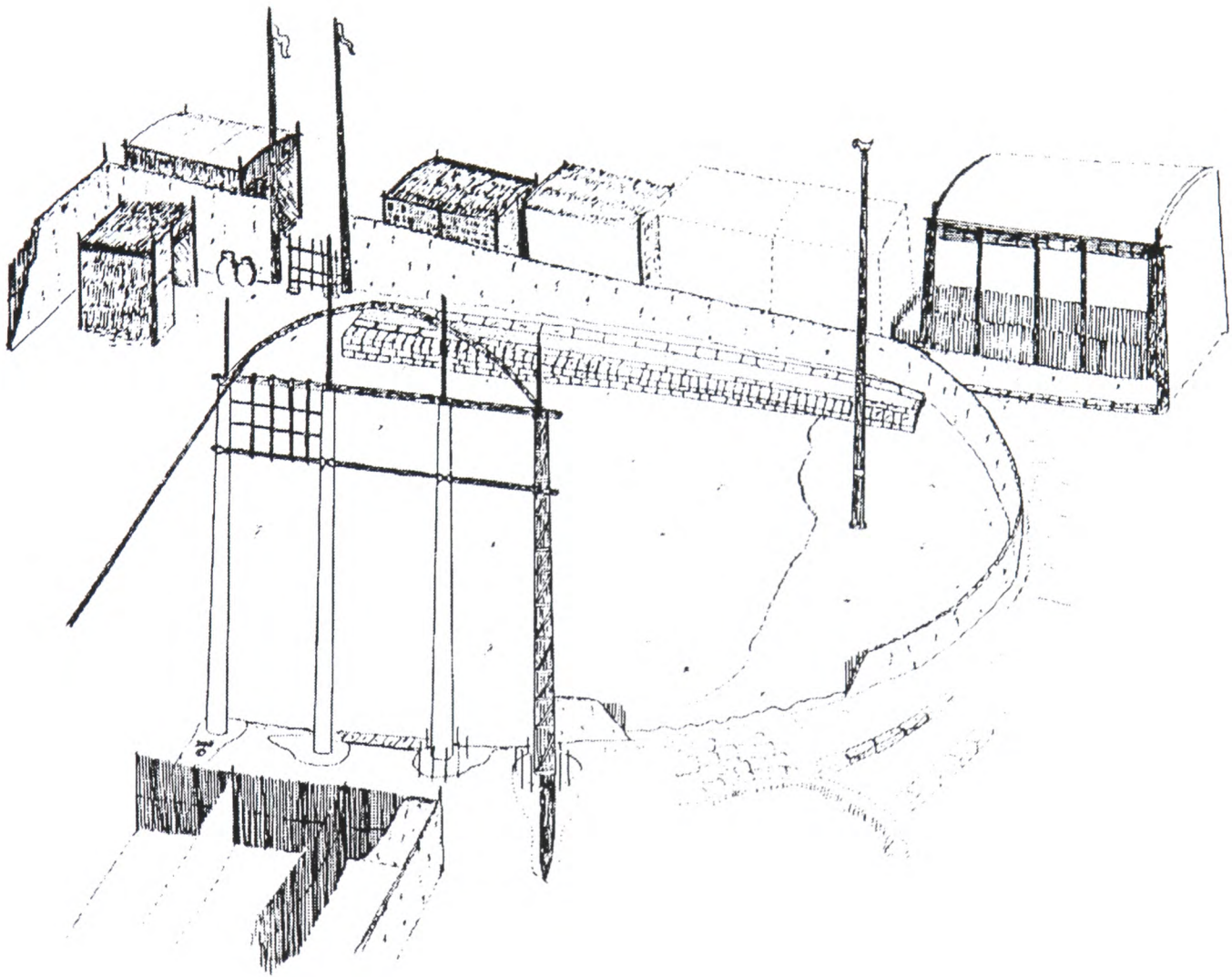


Fig. 61

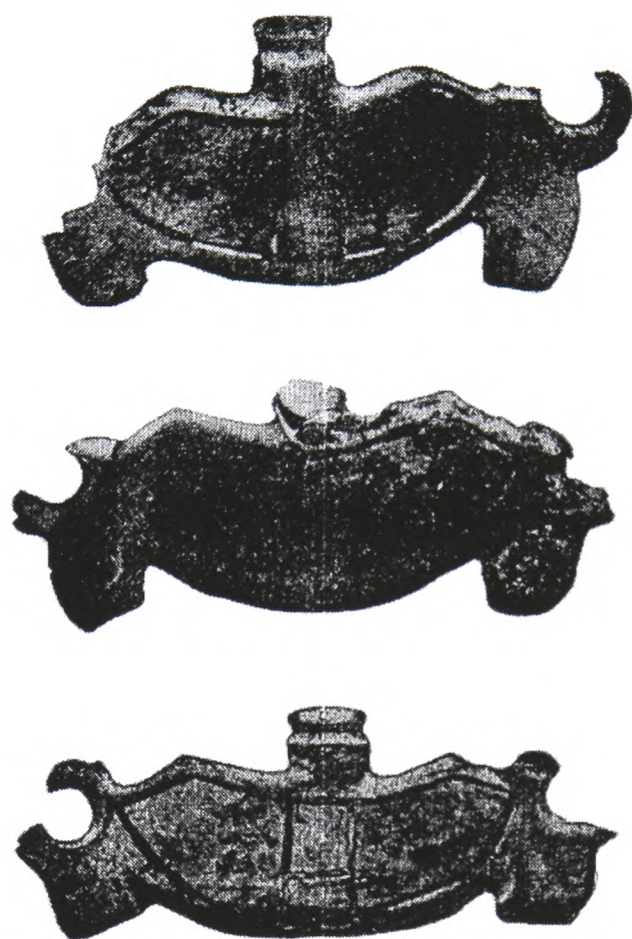


Fig. 62

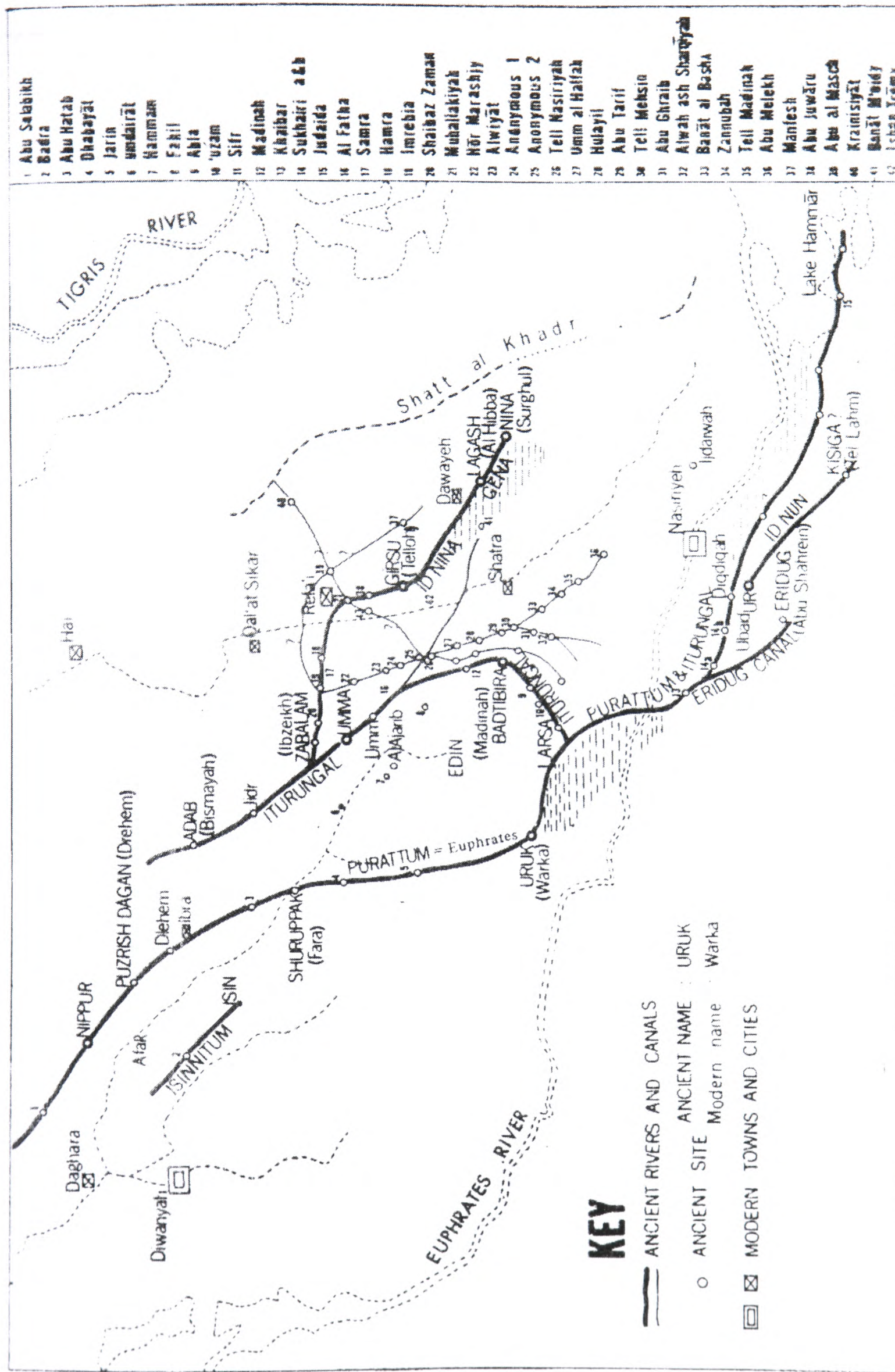


Fig. 63

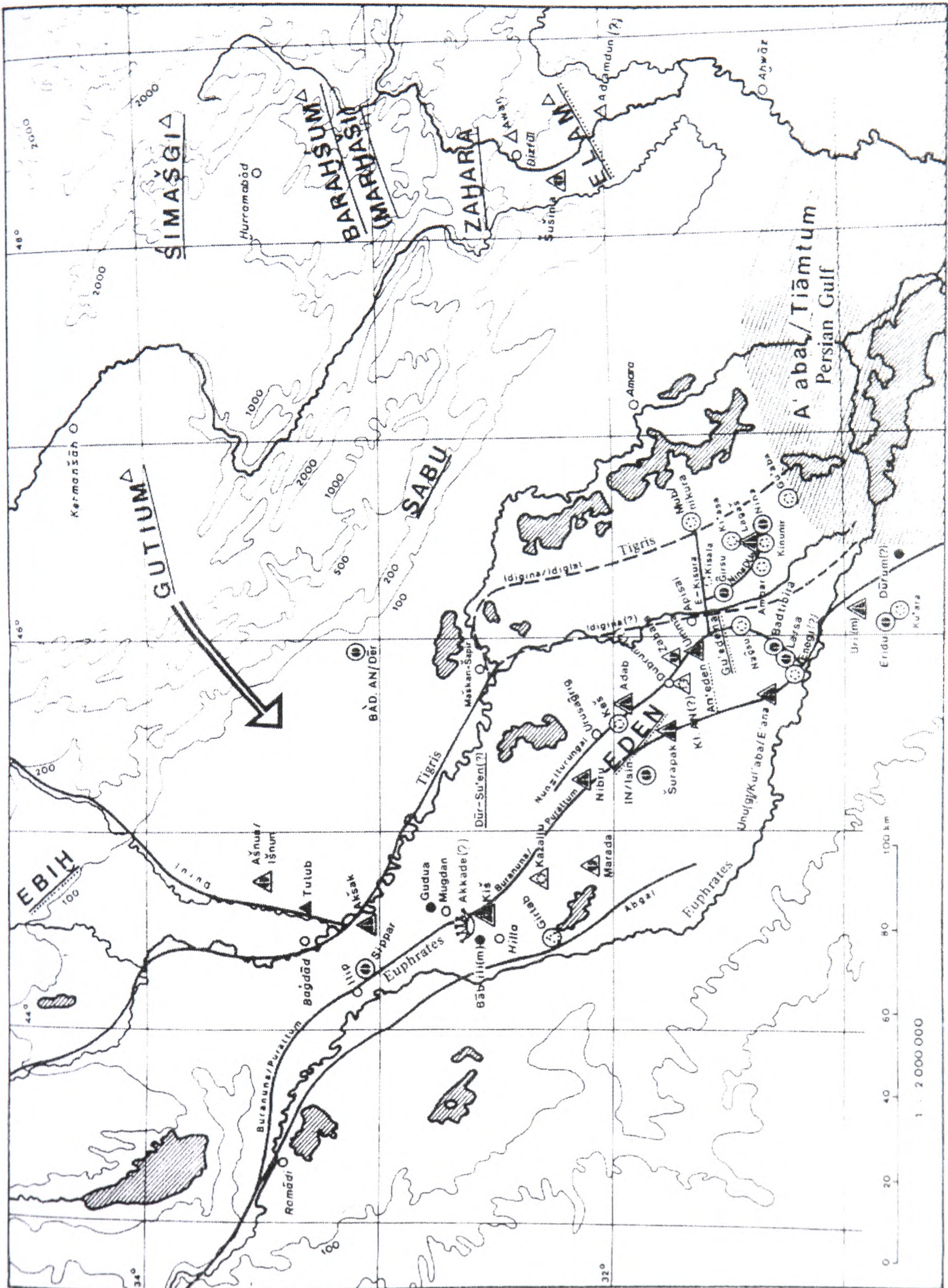


Fig. 64



Fig. 65

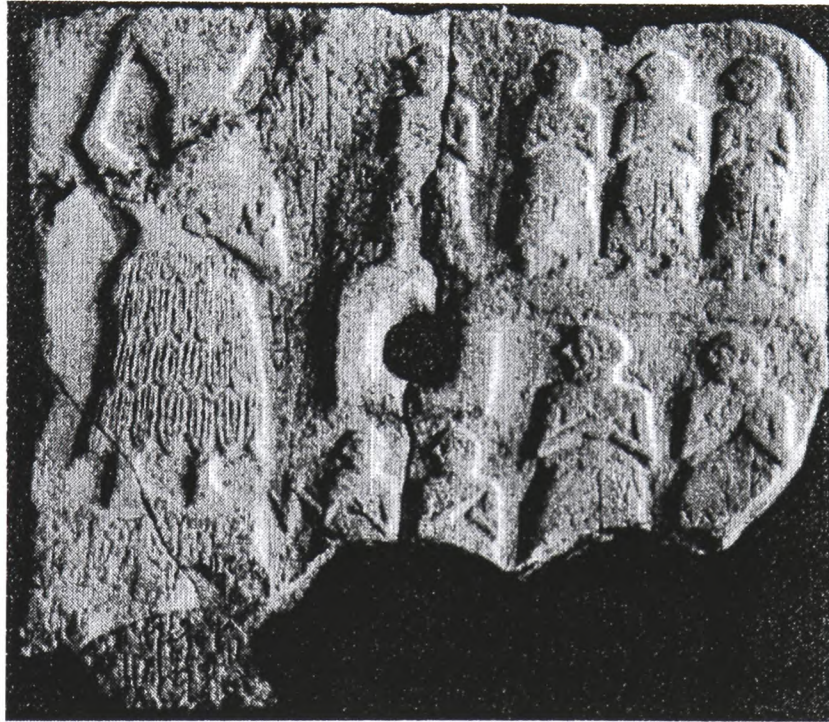


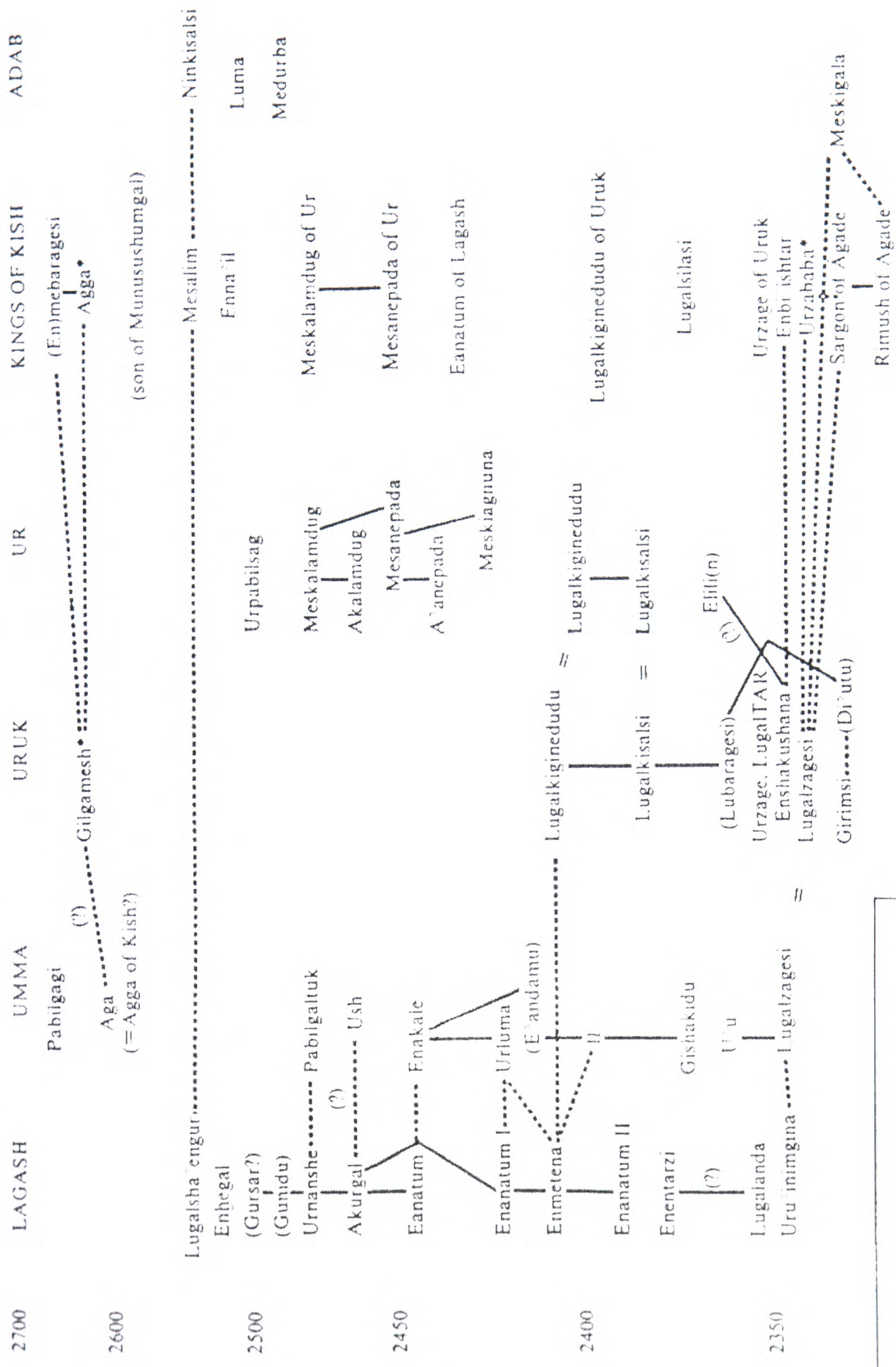
Fig. 66



Fig. 67



# RULERS OF THE PRESARGONIC PERIOD



..... synchronism  
 | filiation  
 ( ) not a ruler  
 \* known from literary tradition only

Fig. 68

Fig. 69

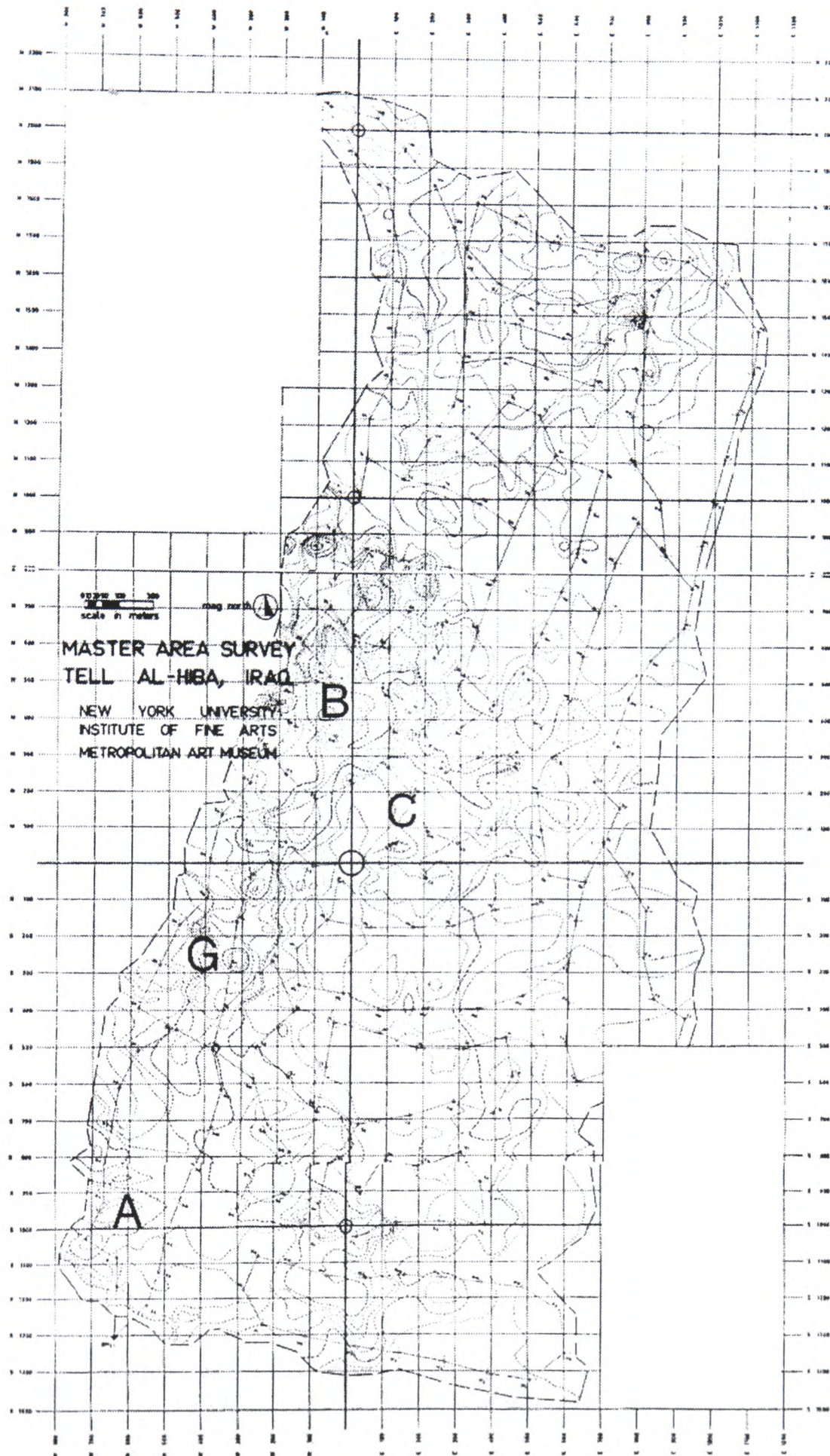


Fig. 70

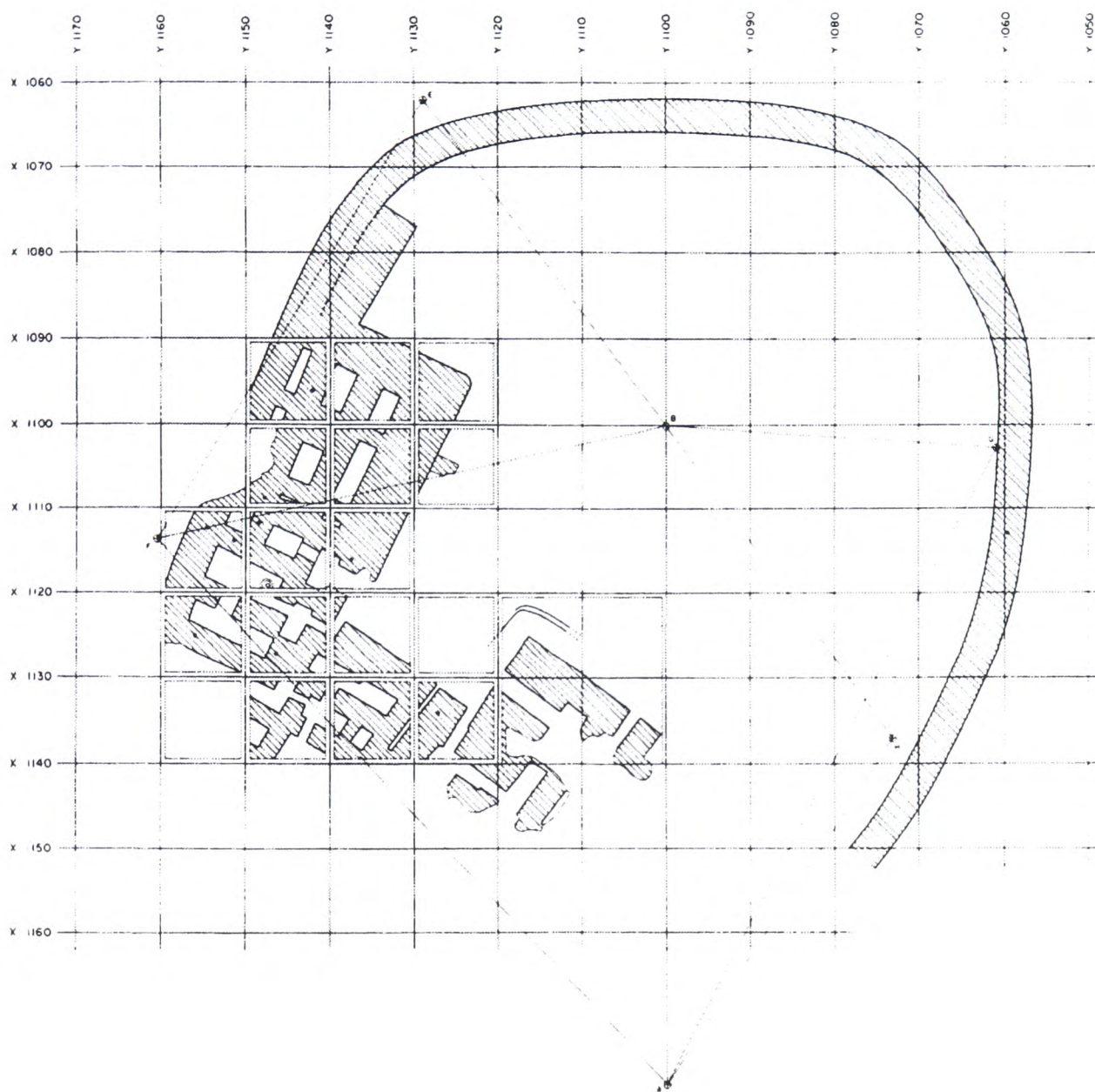


Fig. 71

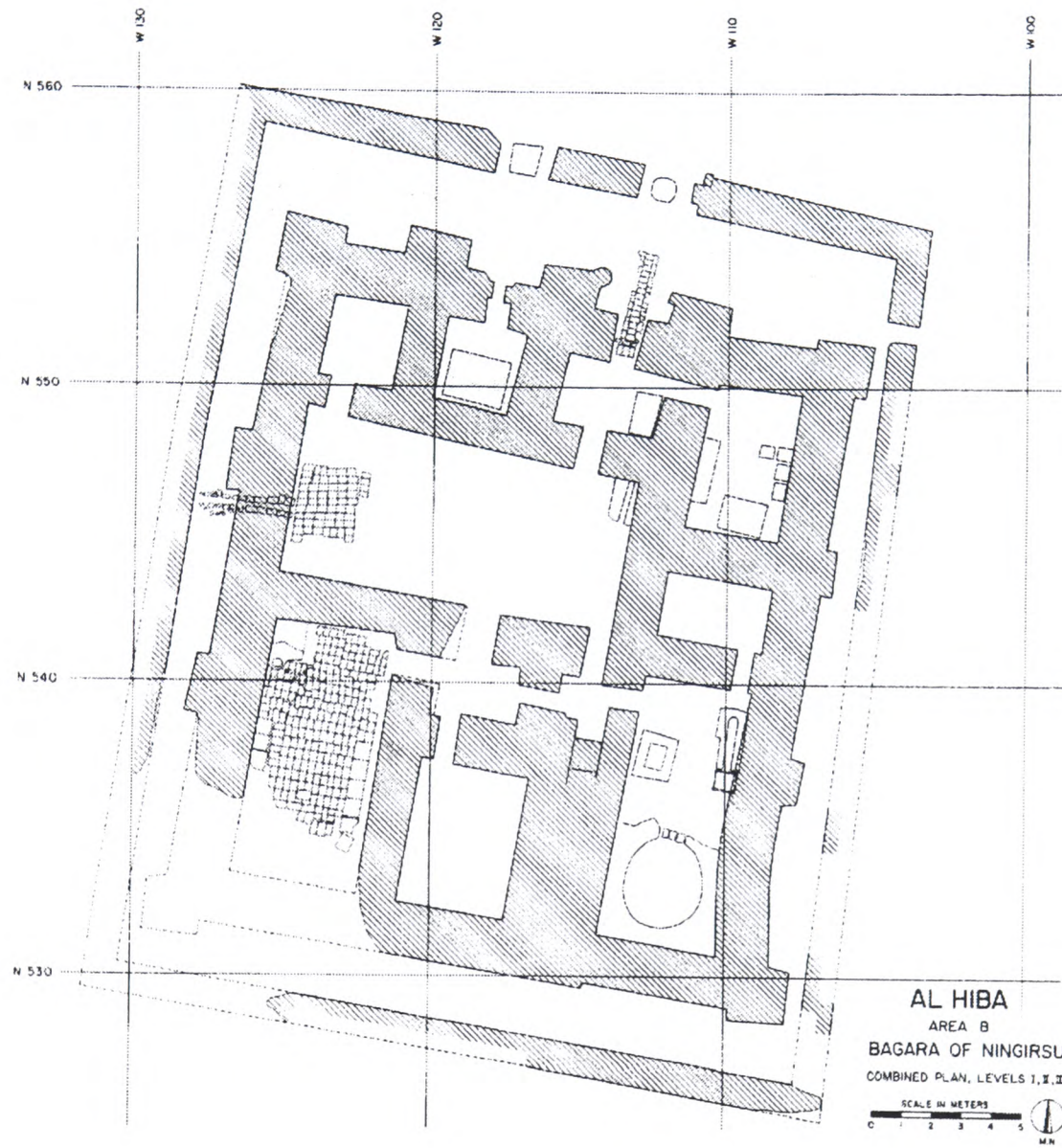


Fig. 72

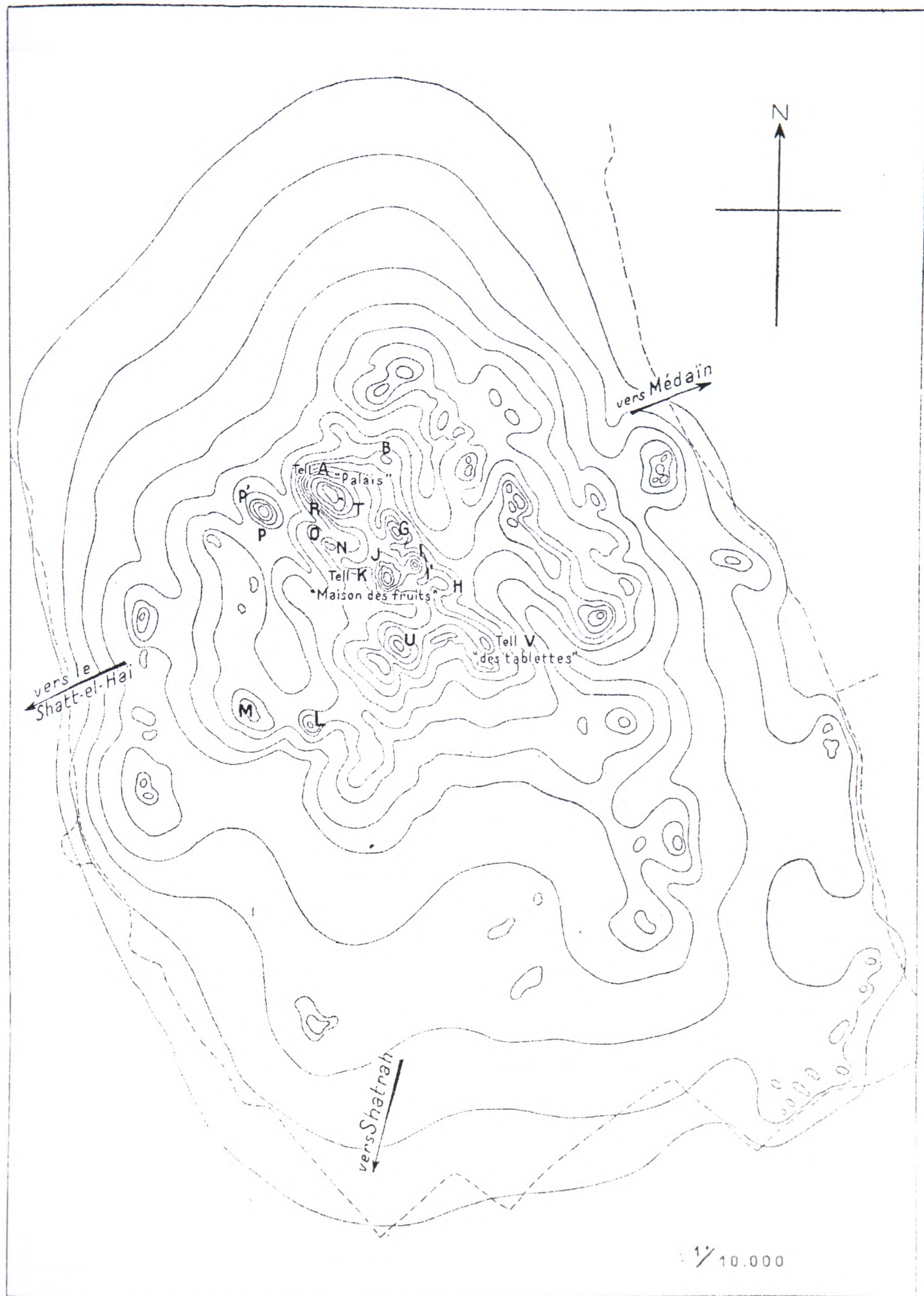


Fig. 73

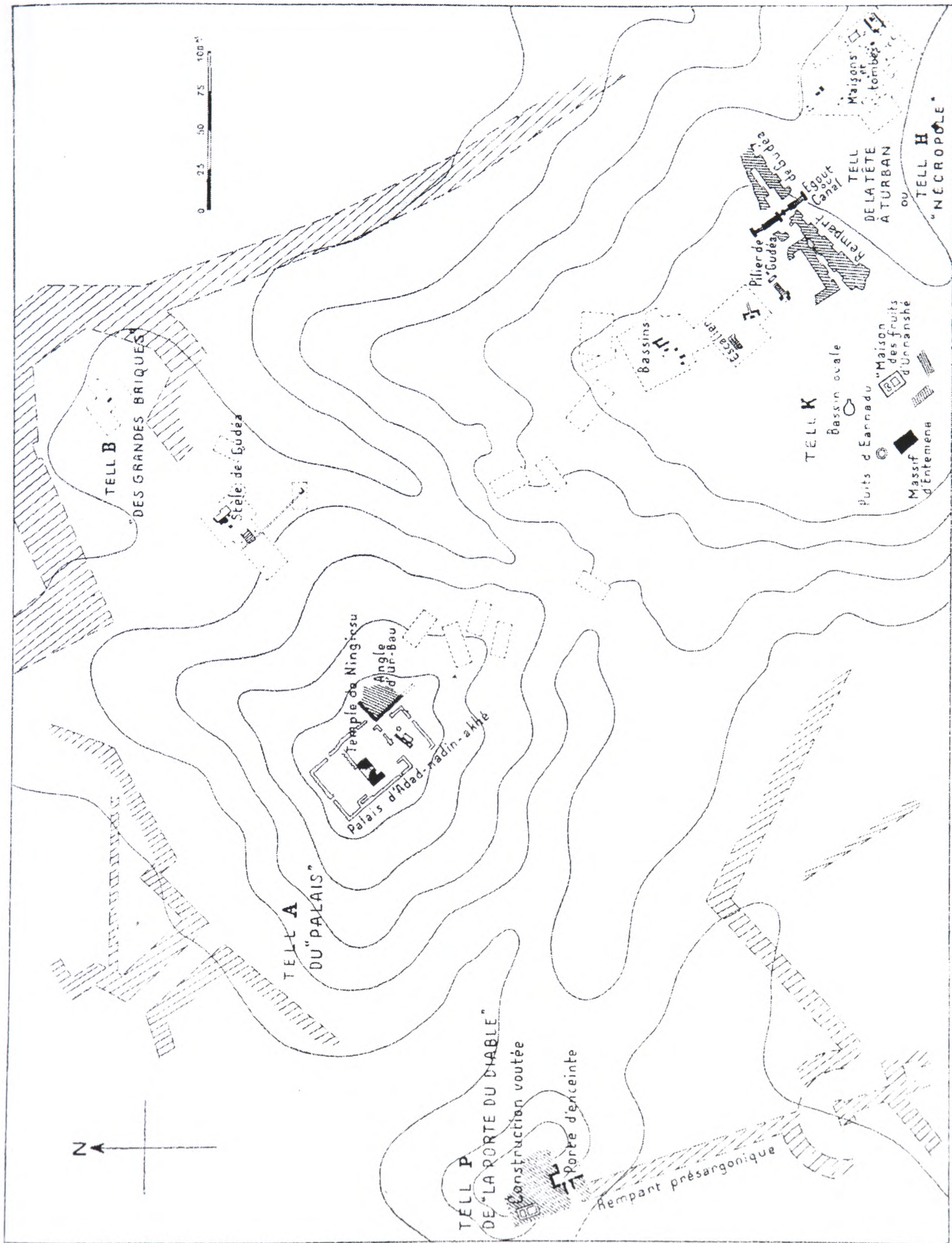


Fig. 74

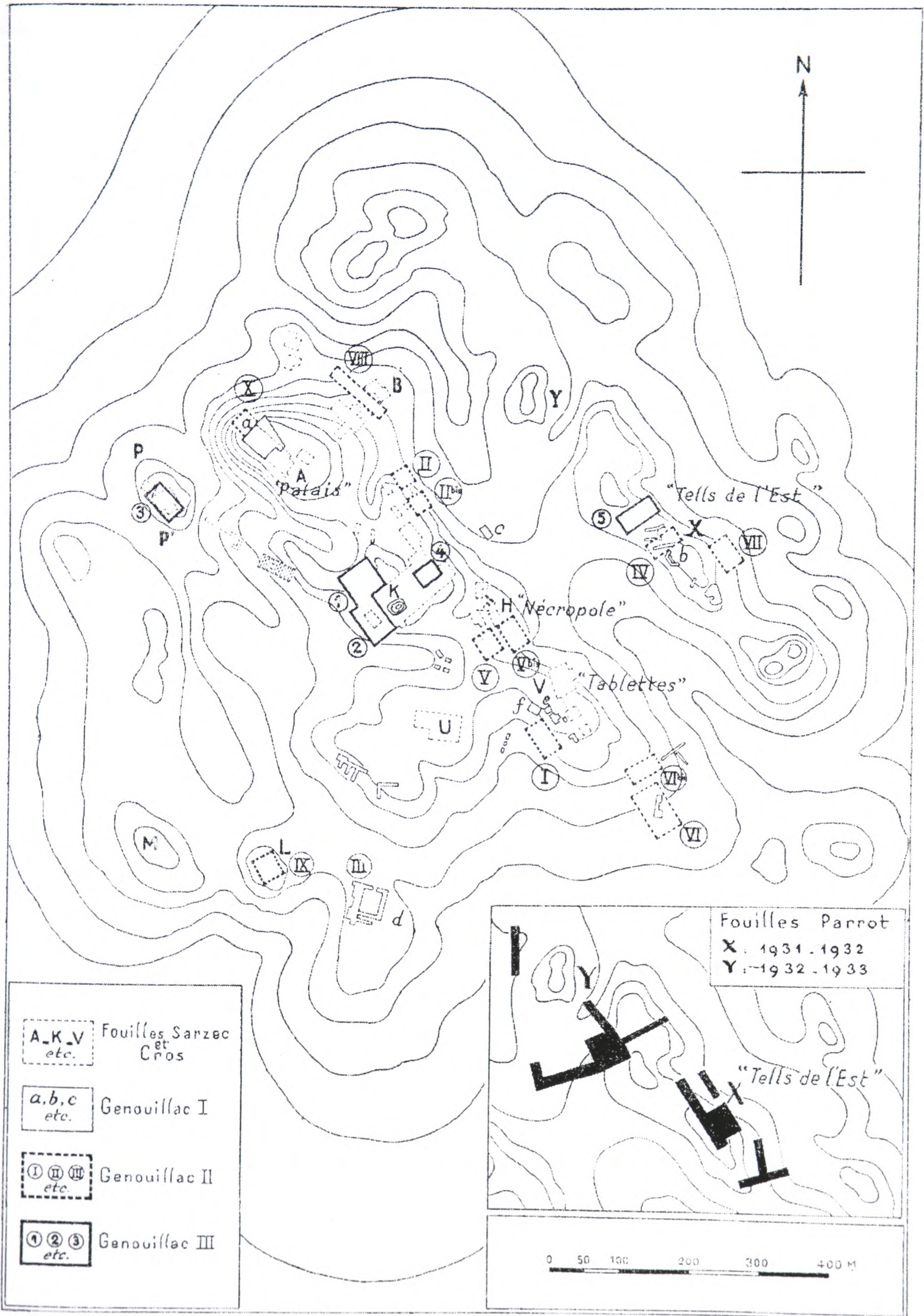


Fig. 75

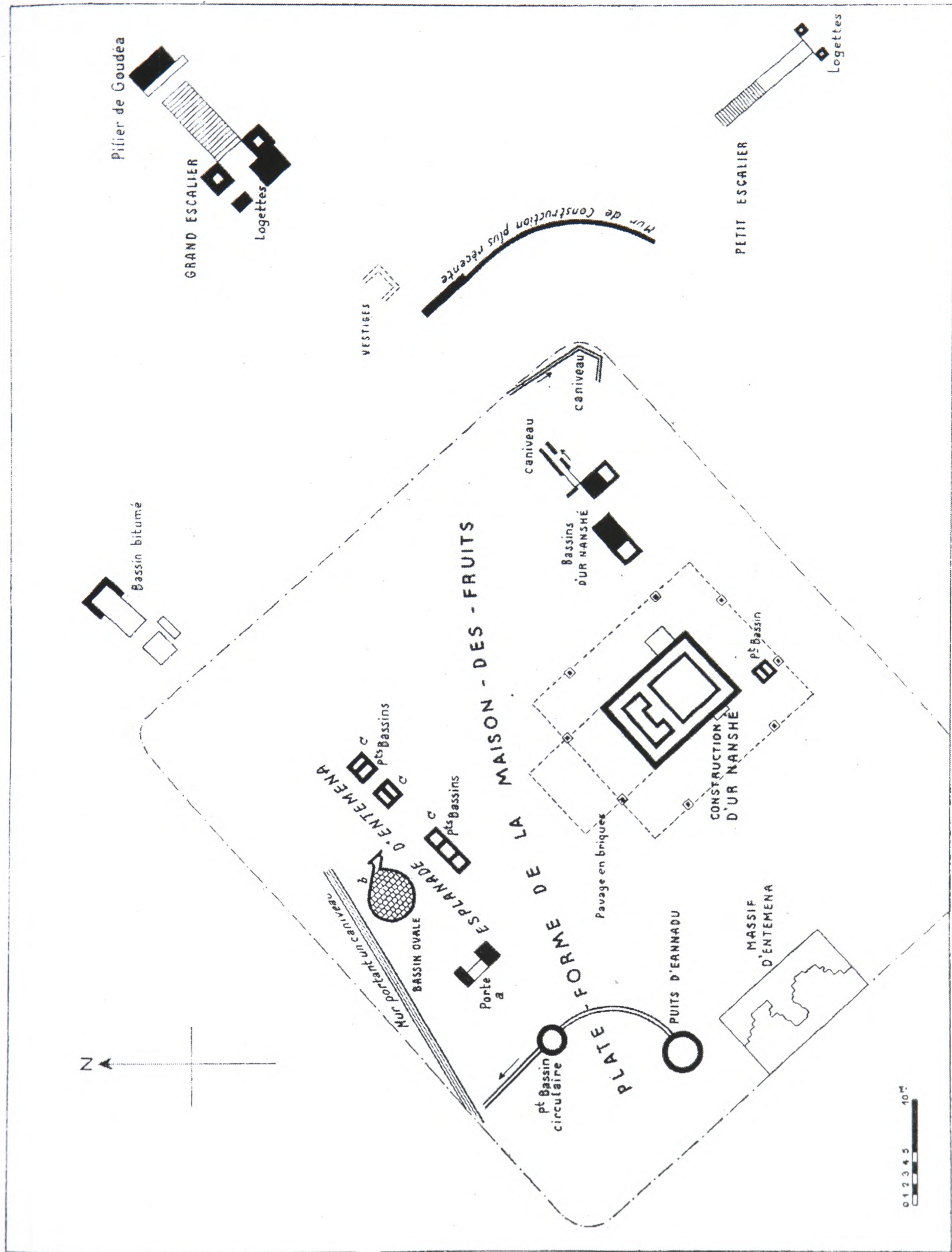
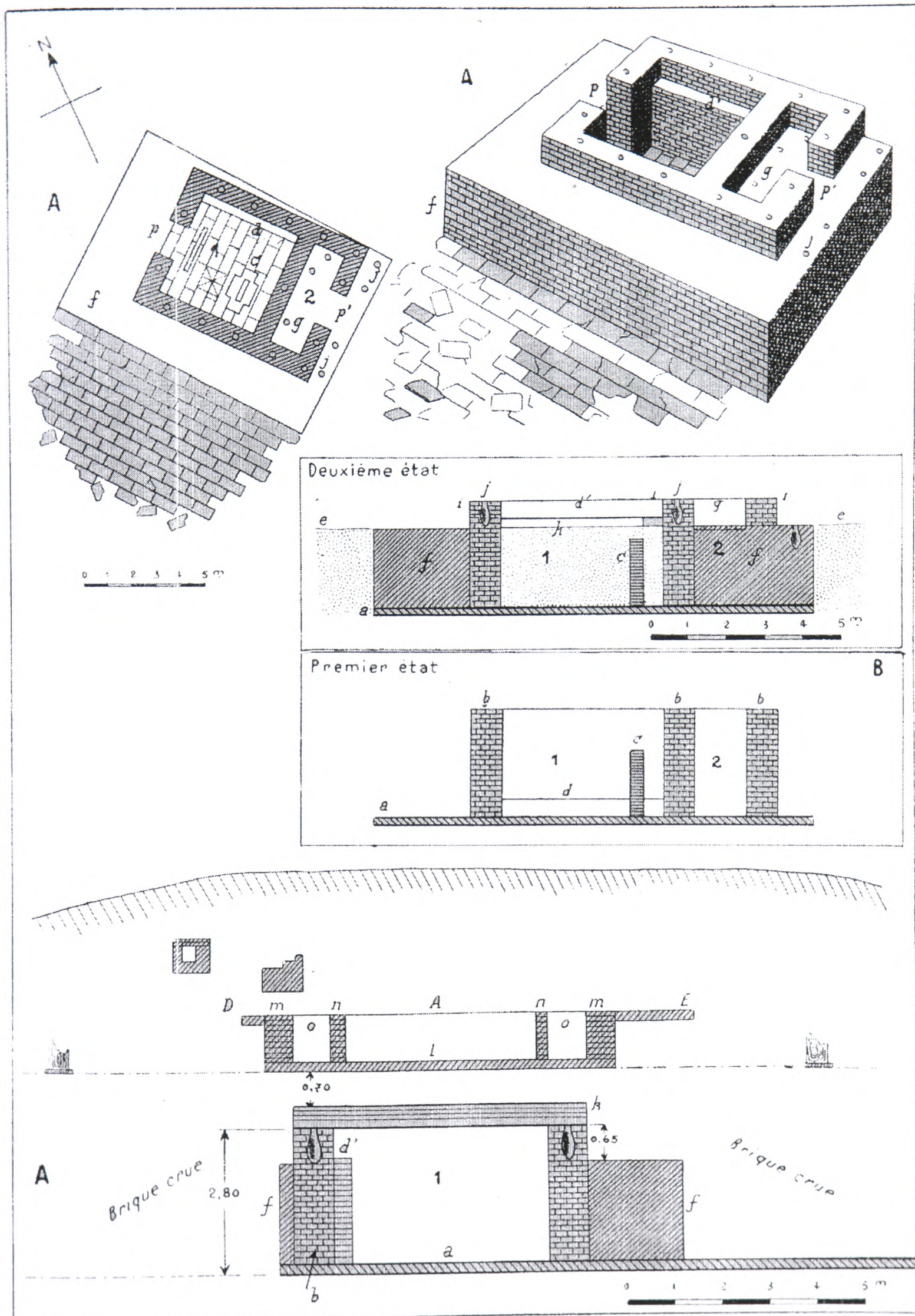
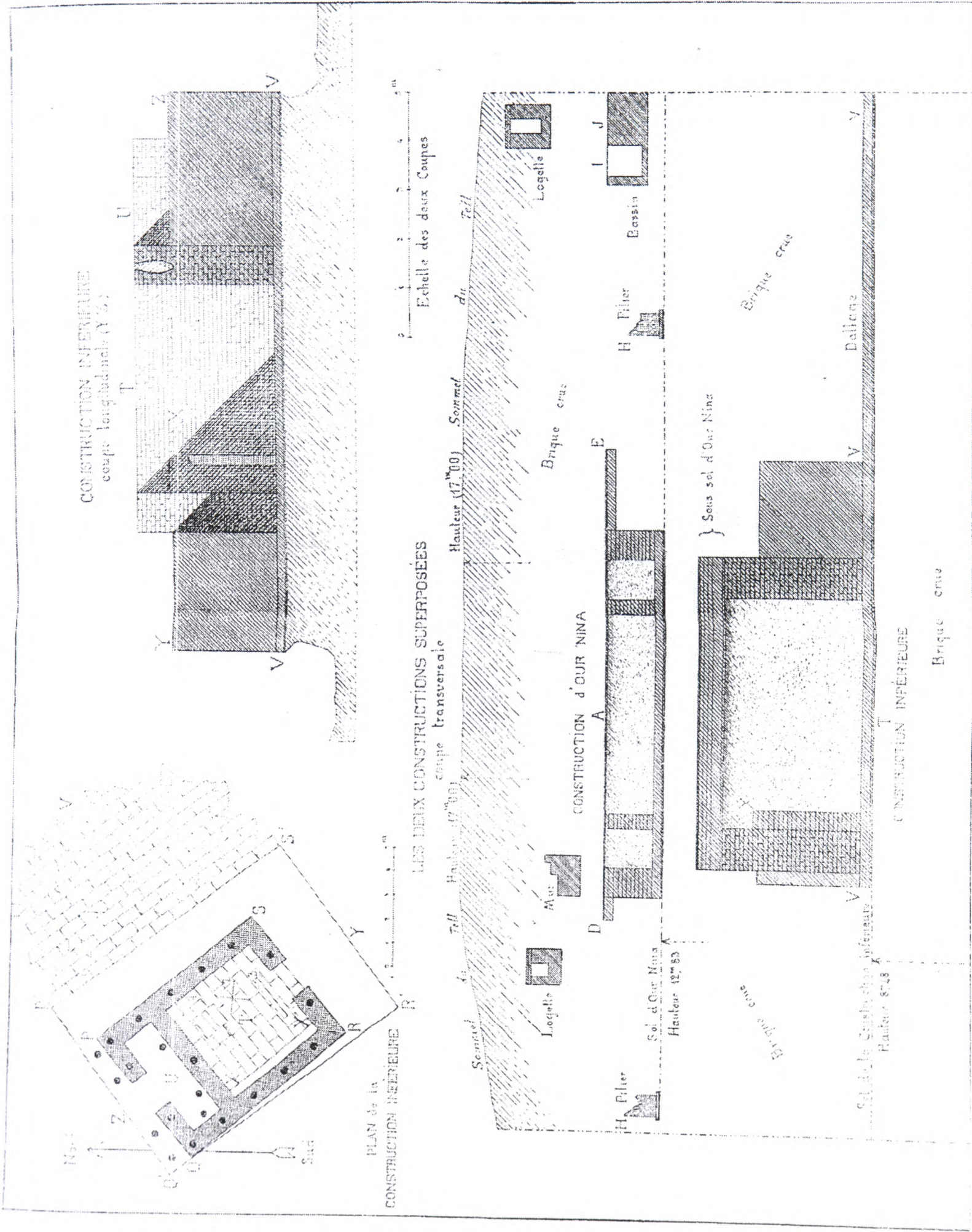


Fig. 76





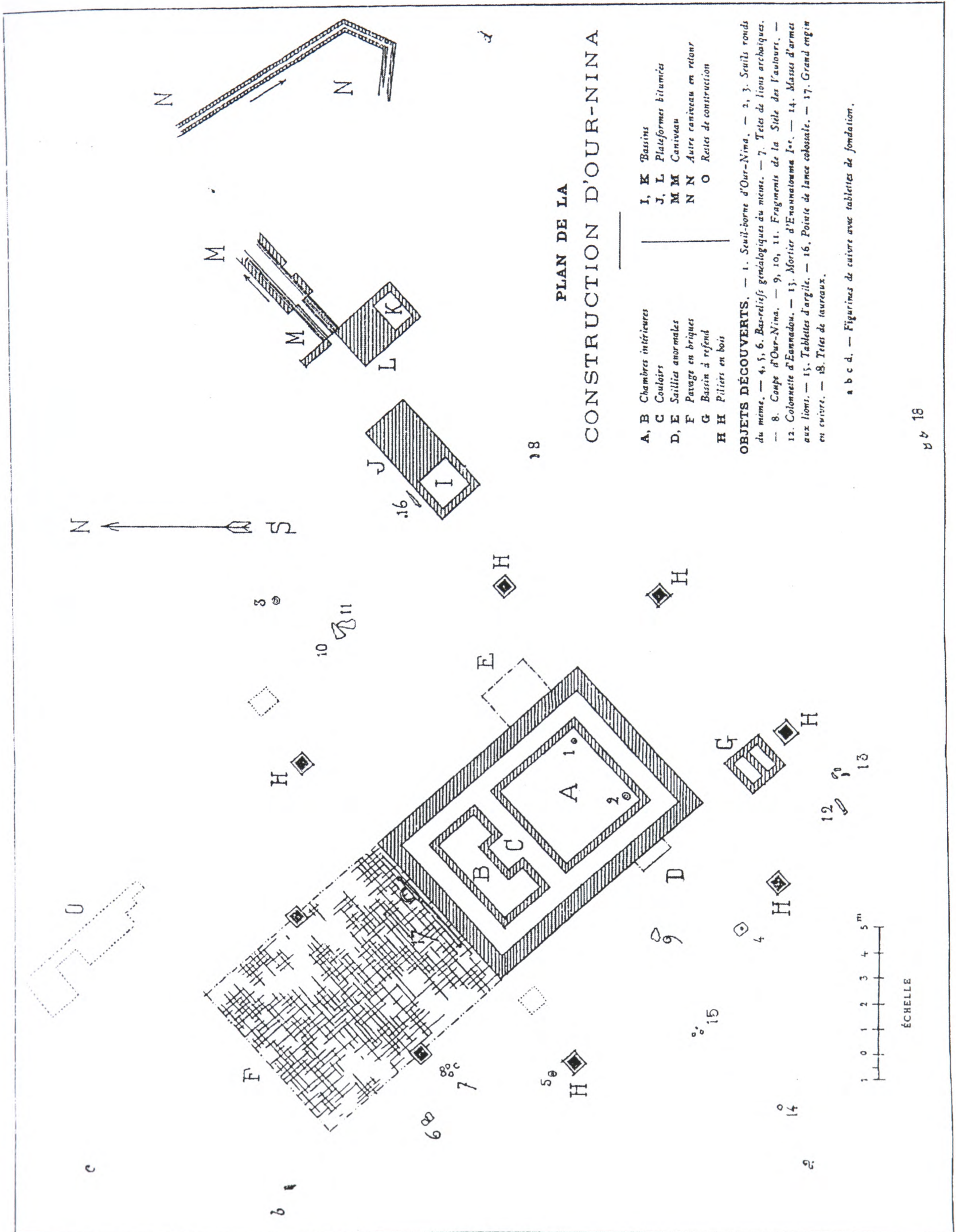


Fig. 79



Fig. 80

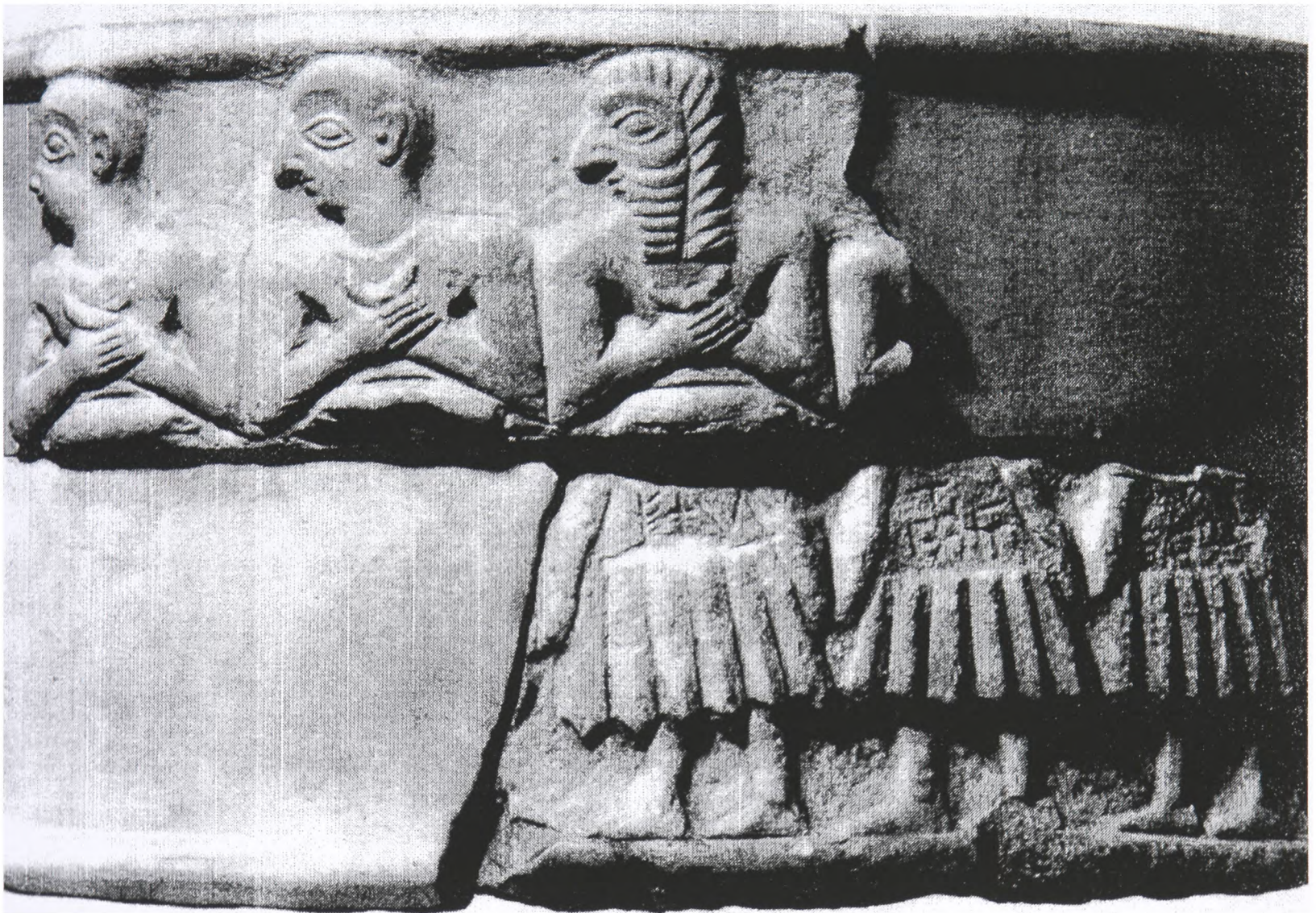


Fig. 81



Fig. 82



Fig. 83

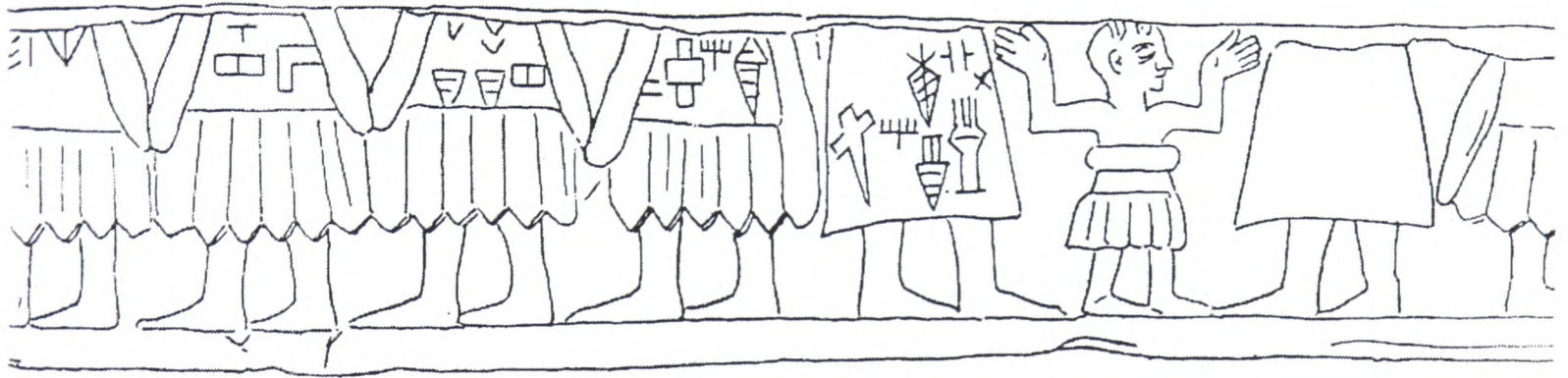


Fig. 84

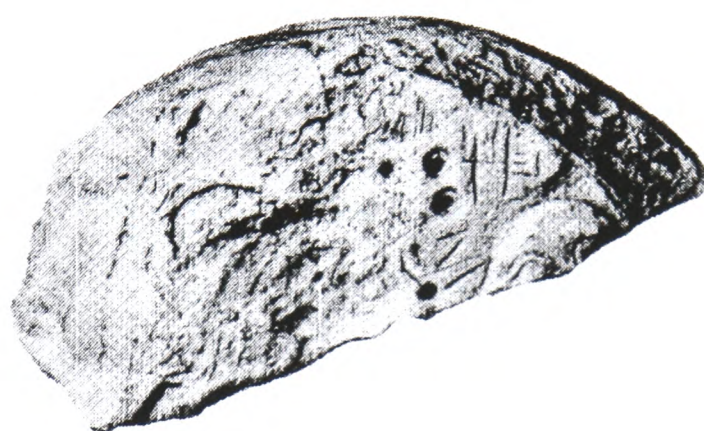


Fig. 85

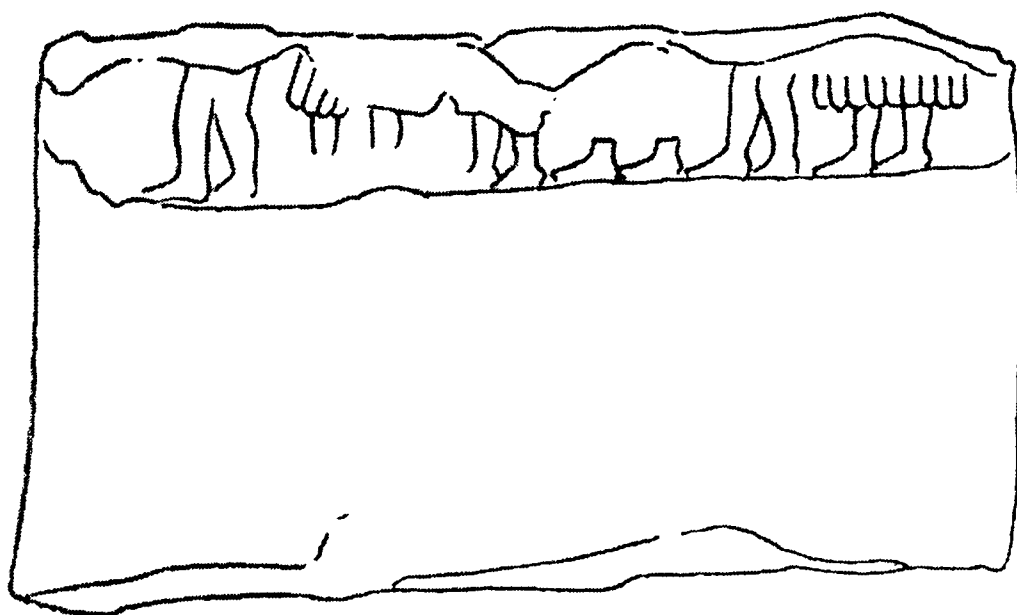


Fig. 86

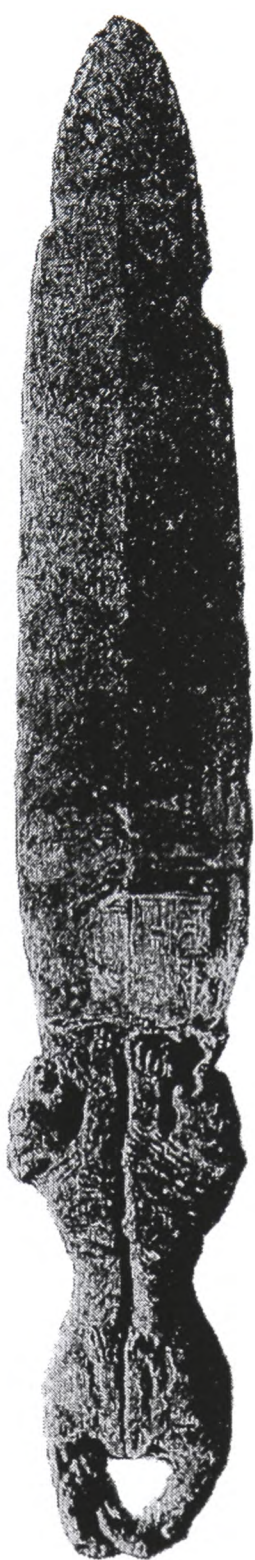


Fig. 87

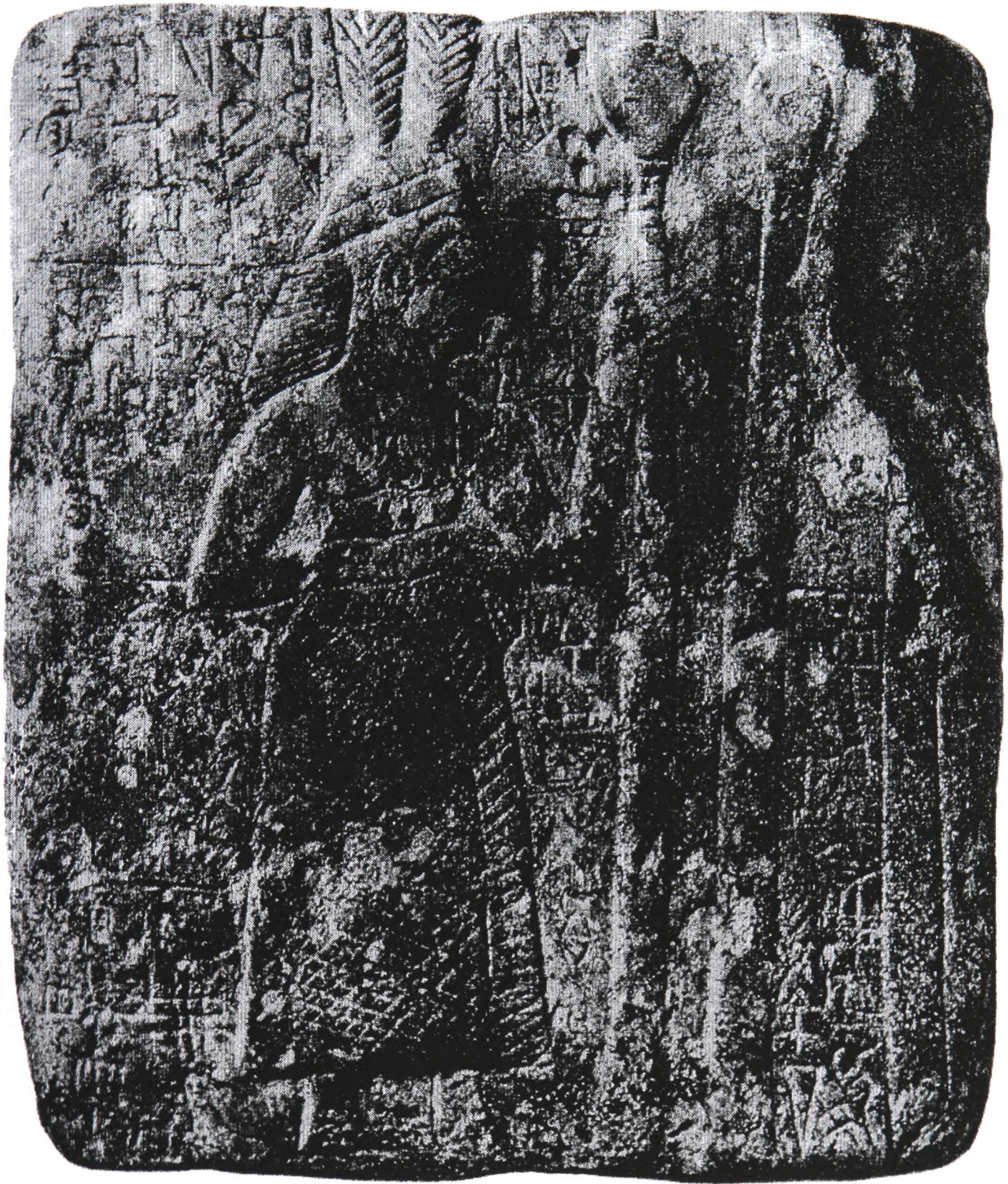


Fig. 88

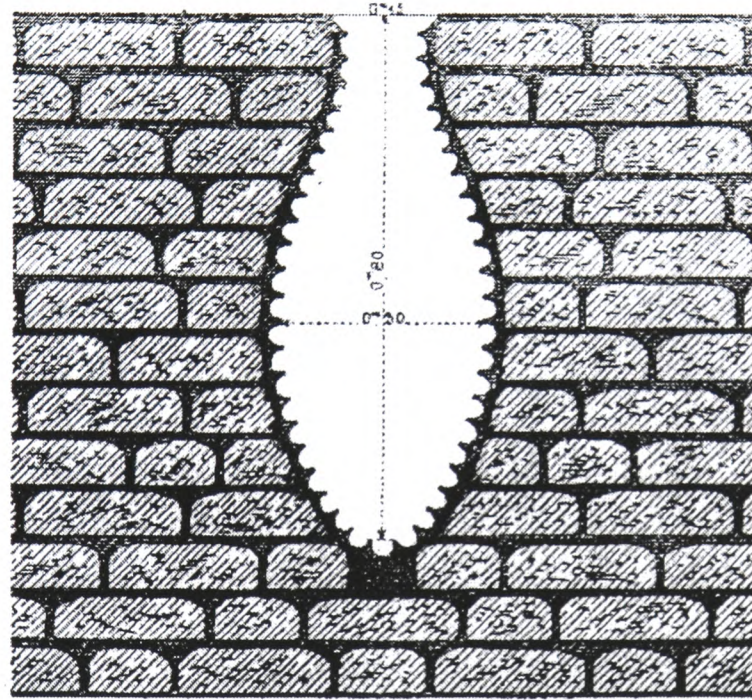
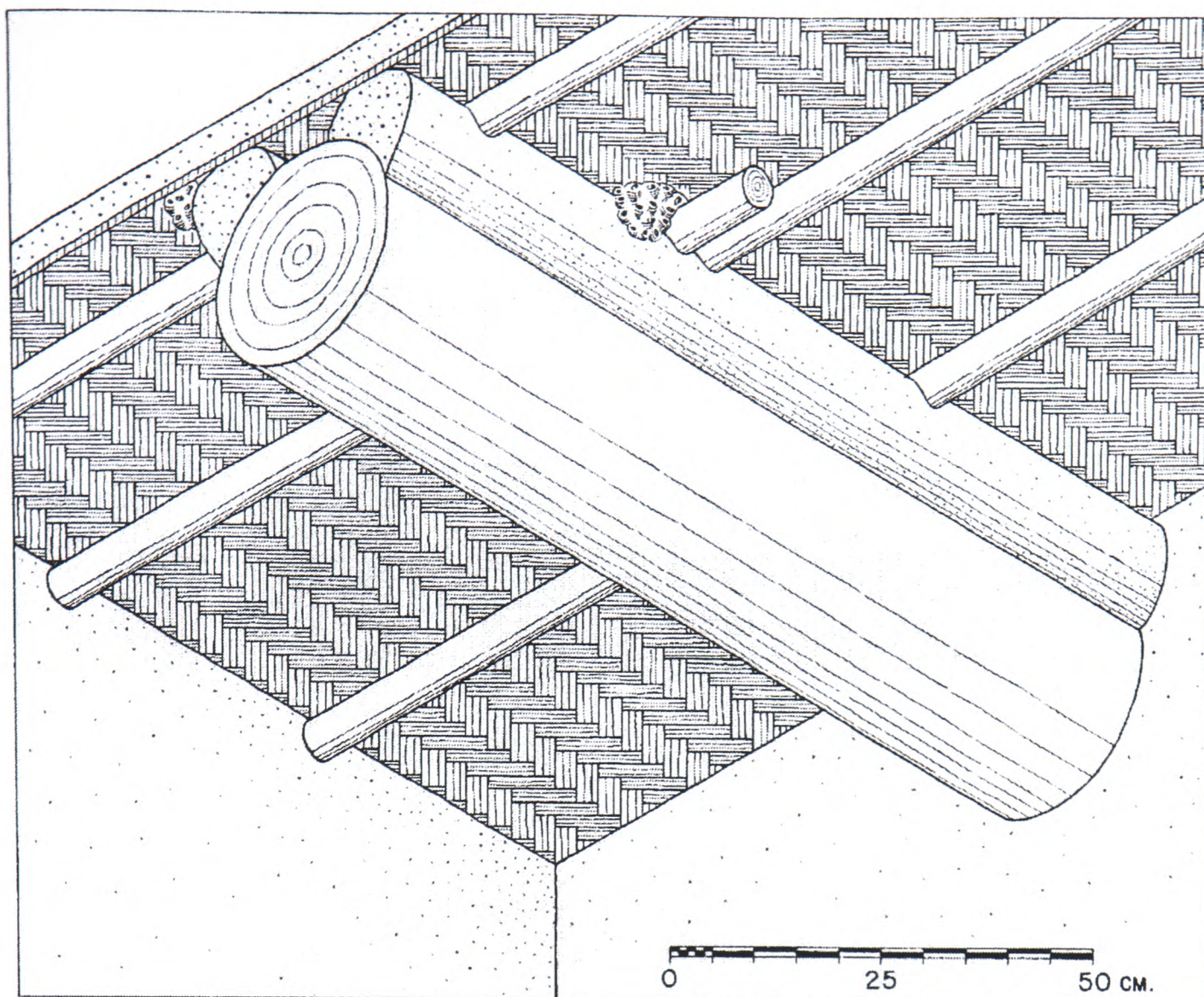


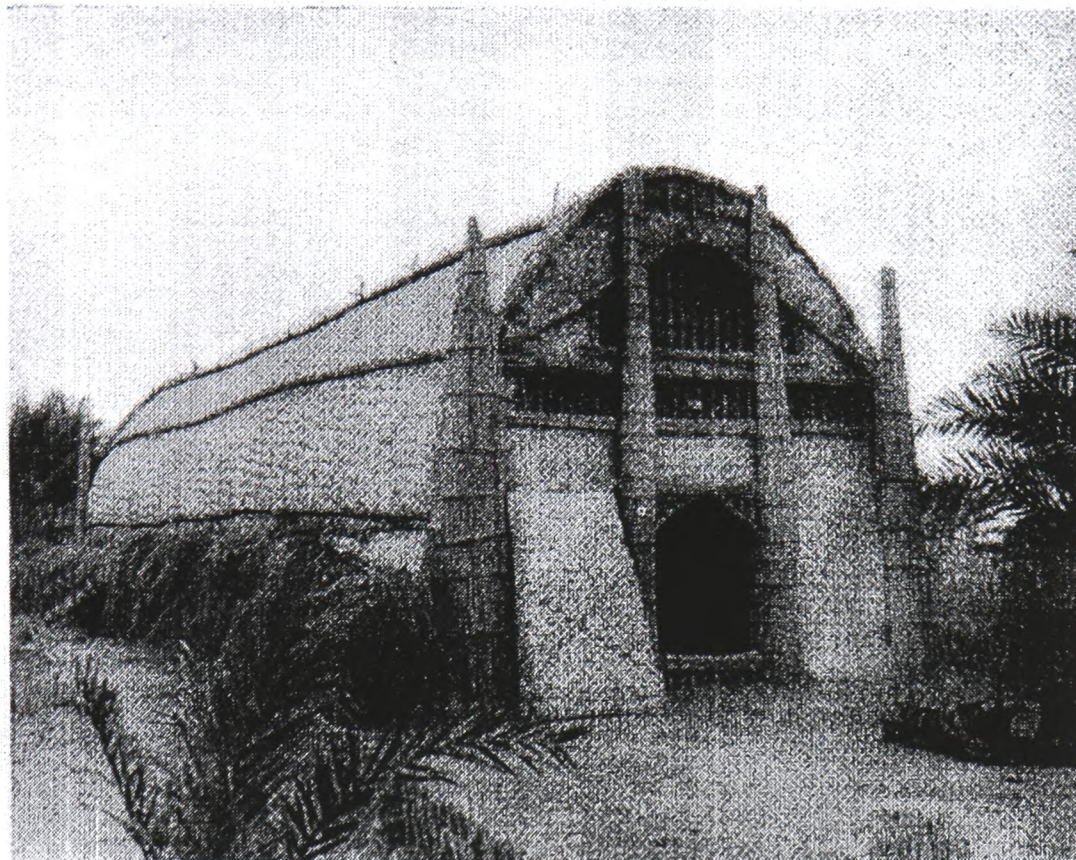
Fig. 89



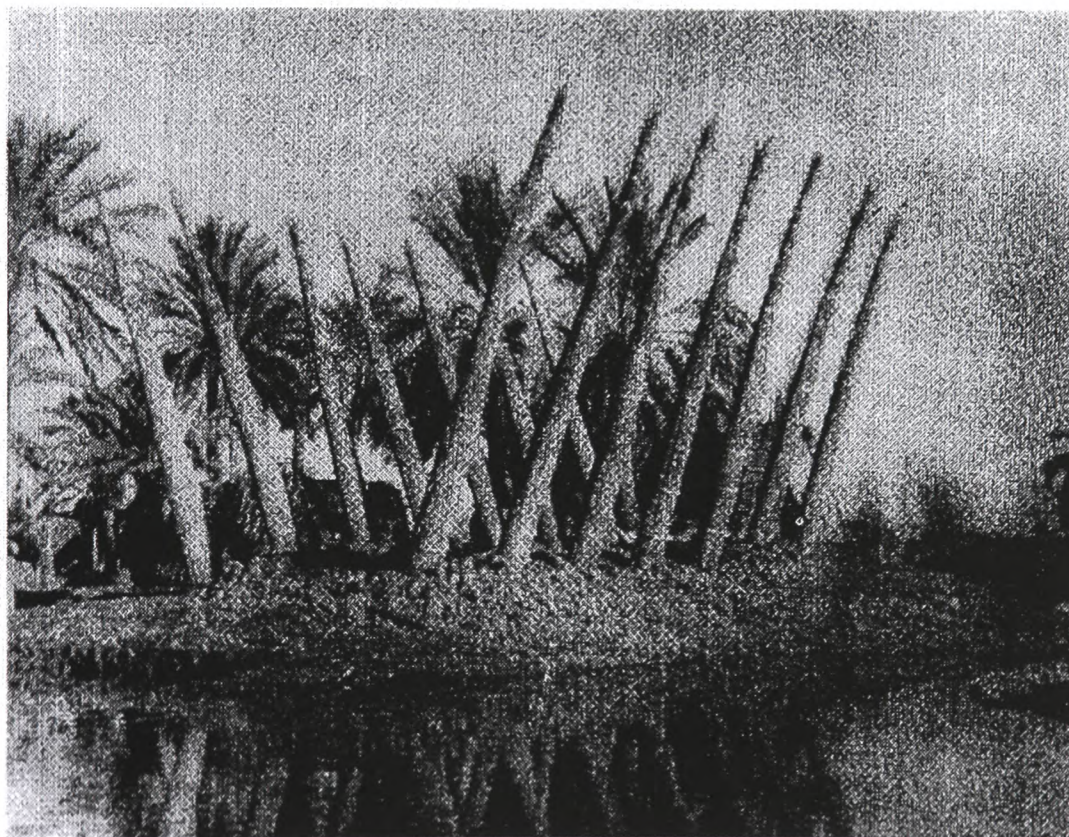
ISOMETRIC DRAWING OF THE RESTORED CEILING OF ROOM L. 43:9, SHOWING DETAILS INDICATED BY REMAINS FOUND IN THE ROOM. SCALE, 1:10



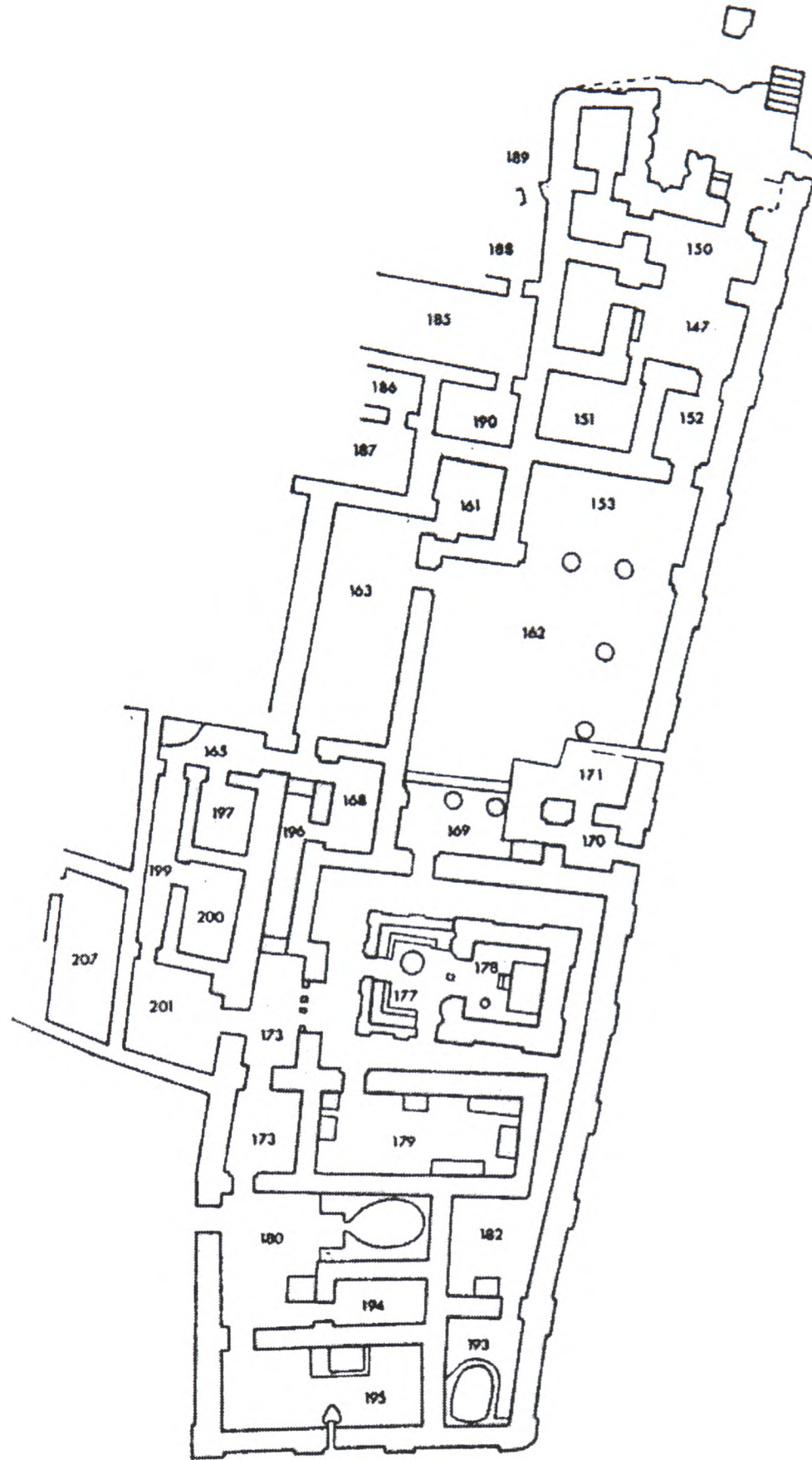
BURNT CLAY SHOWING IMPRESSIONS OF REEDS PROBABLY USED IN ROOFING



A. A guest house



B. A reed hut in an early stage of building



Nippur, Inanna Temple VIIB

Fig. 92

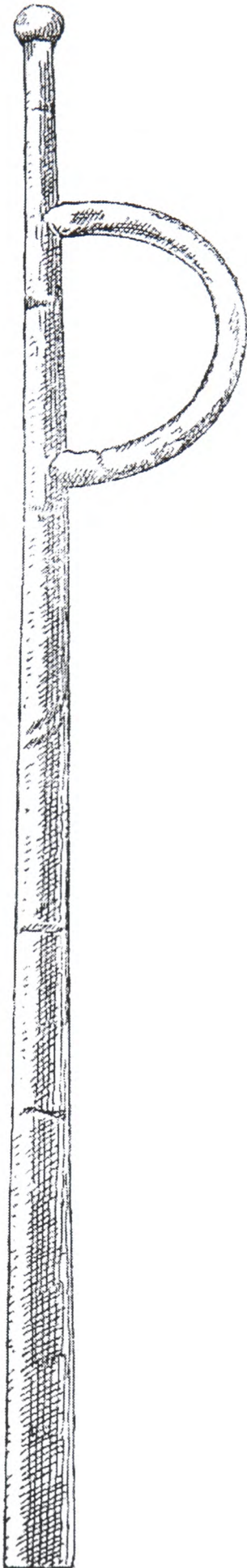


Fig. 93



Fig. 94



Fig. 95



Fig. 96



Fig. 97

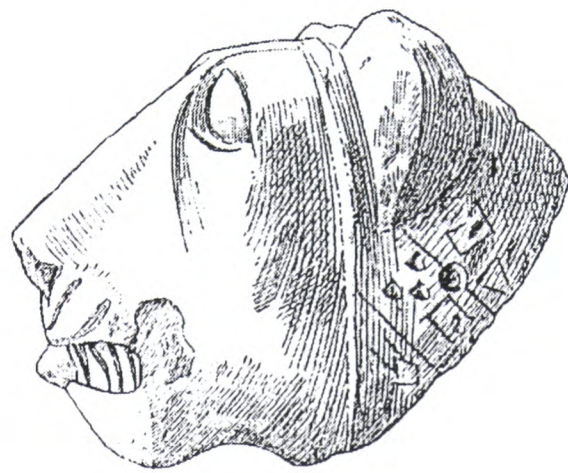


Fig. 98



Fig. 99

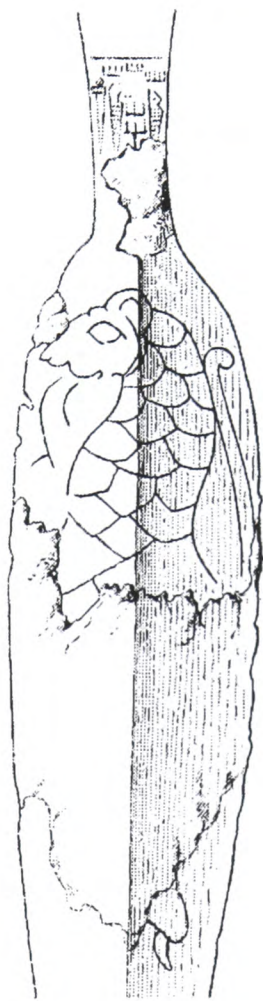


Fig.100



Fig.101



Fig.102



Fig.103

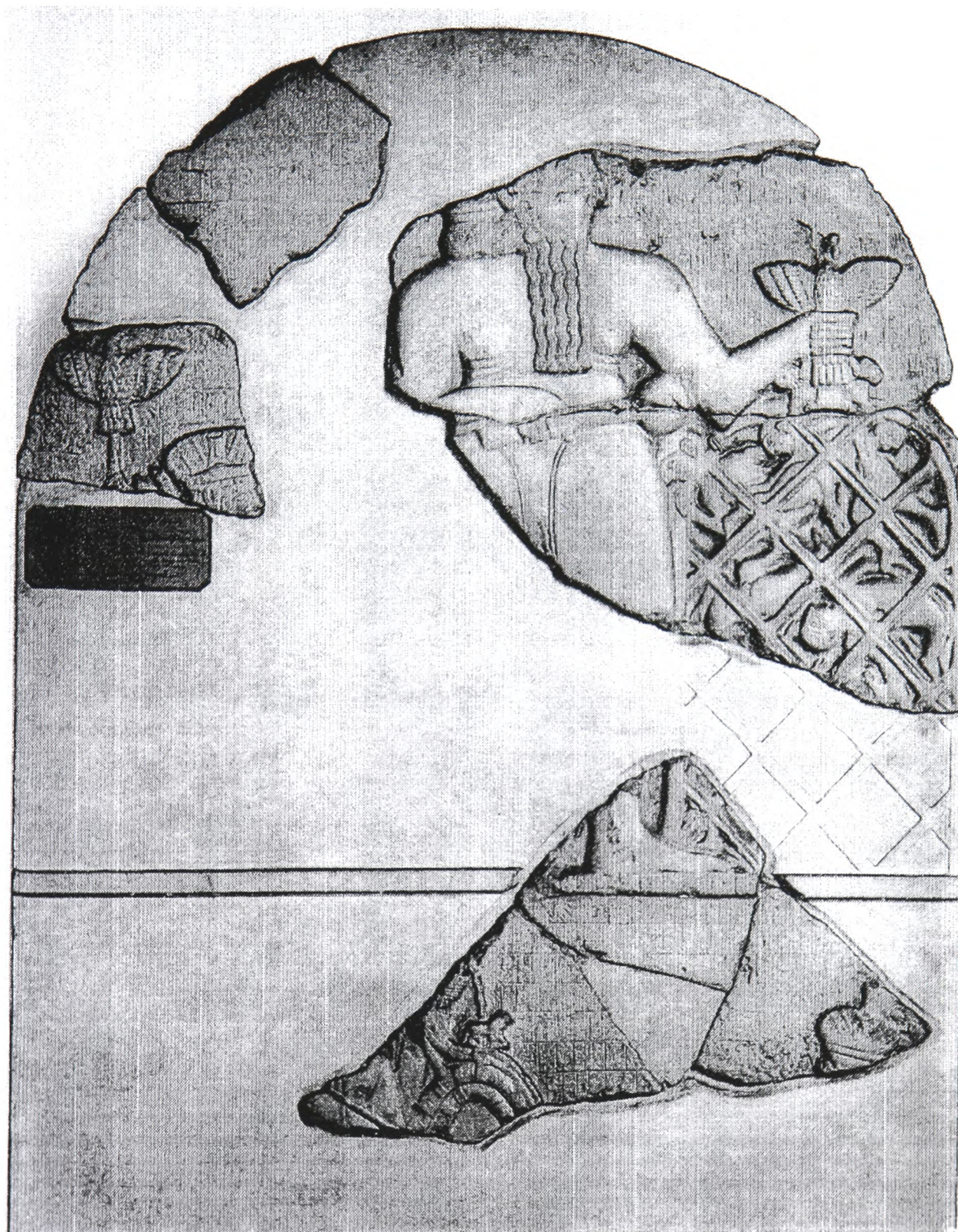


Fig.104



Fig.105



Fig.106

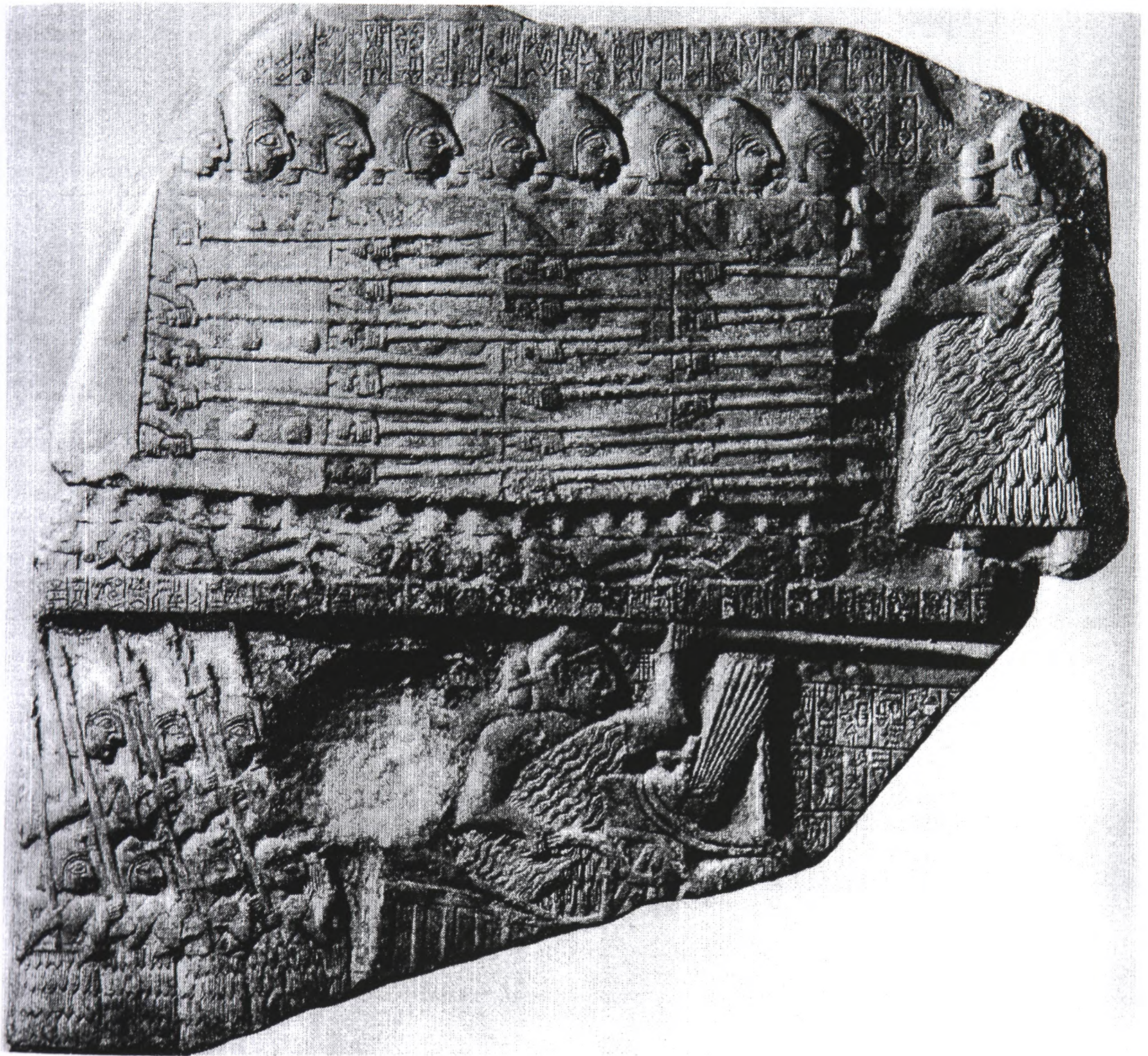


Fig.107



Fig.108



Fig.109



Fig.110

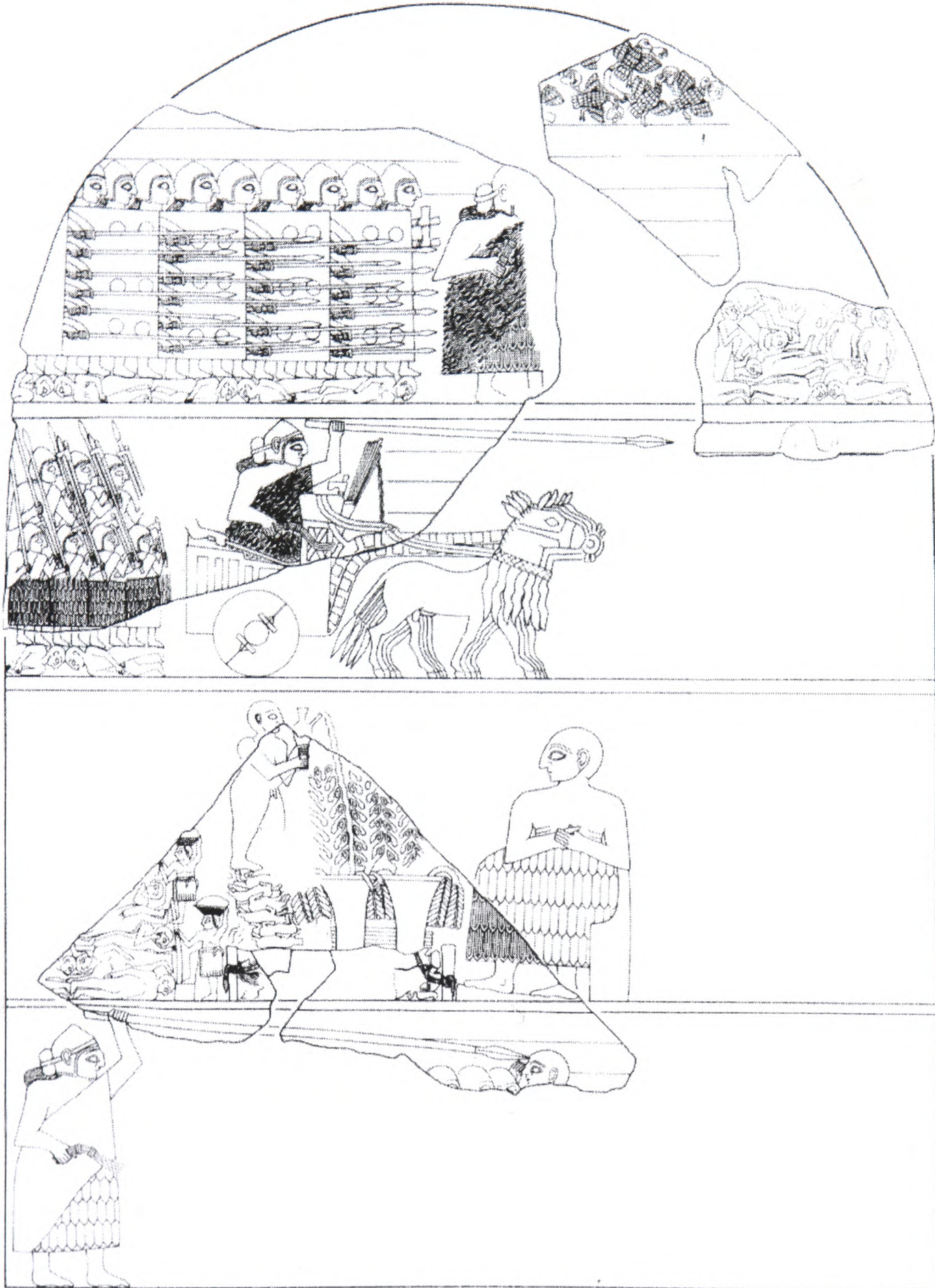


Fig.111



Fig.112



Fig.113

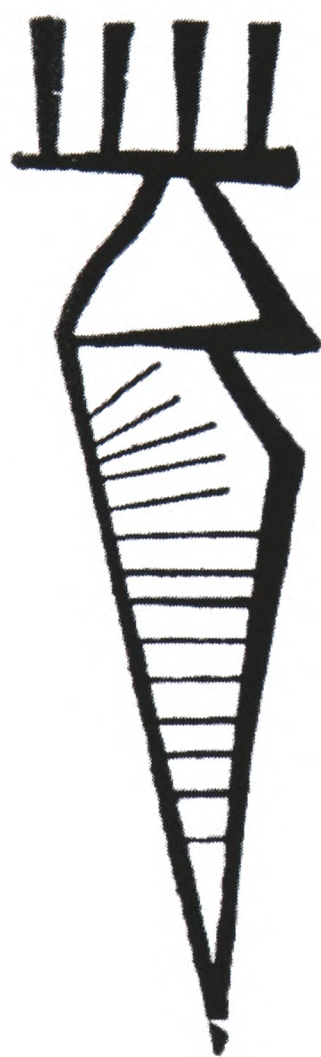
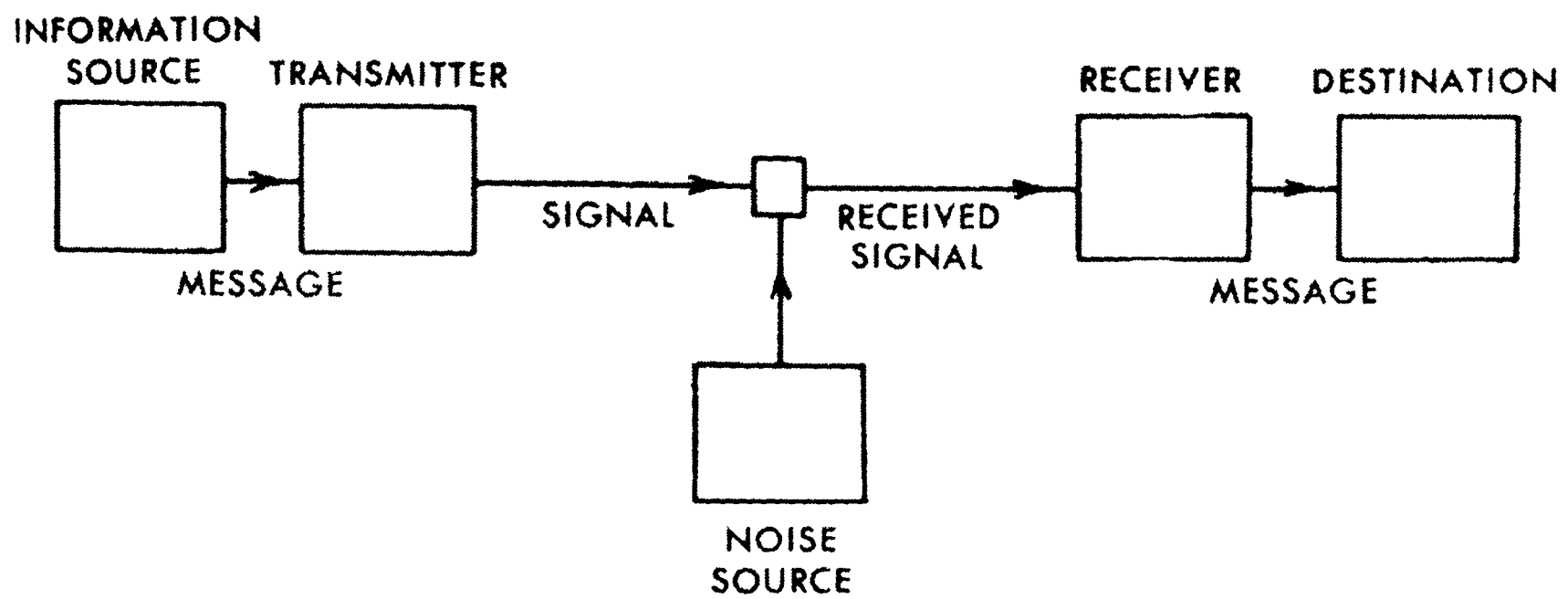


Fig.14





Schematic diagram of a general communication system.



A picture drawn by a 10-year-old at Public School 29 in Brooklyn on the day of the attack.

Fig.117



Fig.118



Fig.119



Fig.120



Fig.121



Fig.122

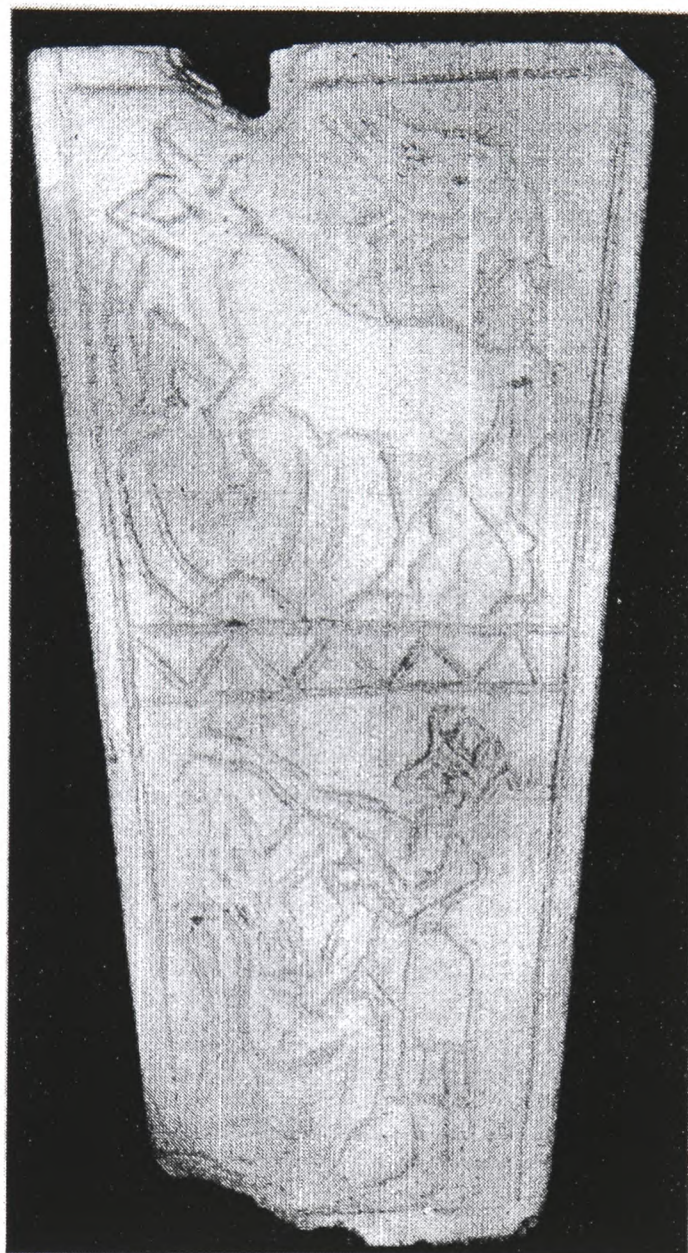


Fig.123



Fig.124

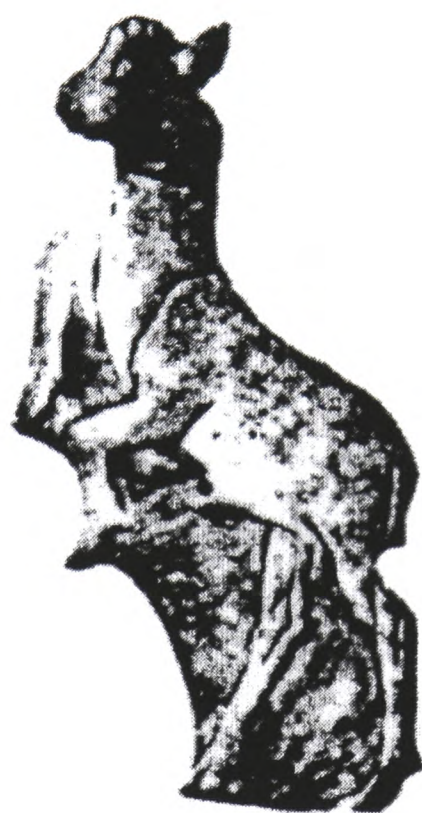


Fig.125



Fig.126

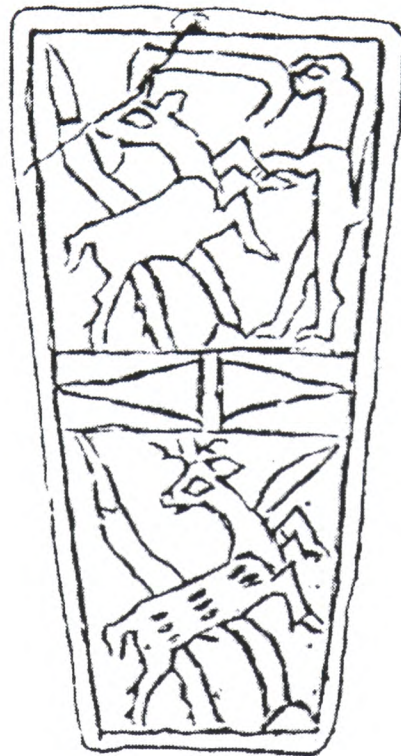


Fig.127

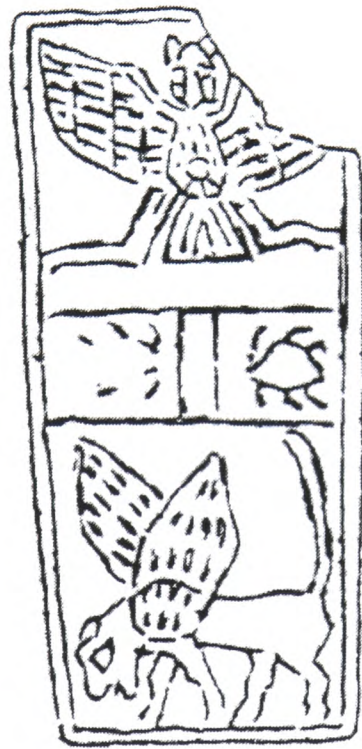


Fig.128



Fig.129

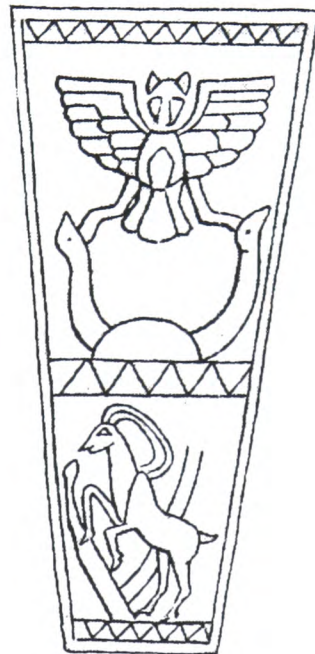


Fig.130

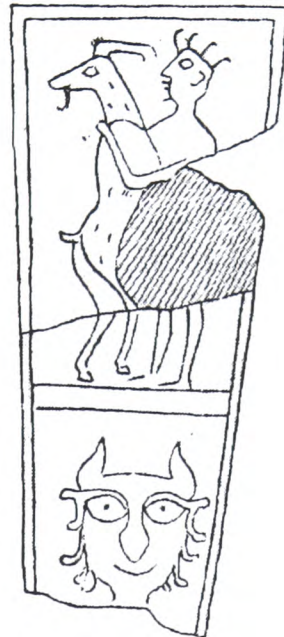


Fig.131



Fig.132

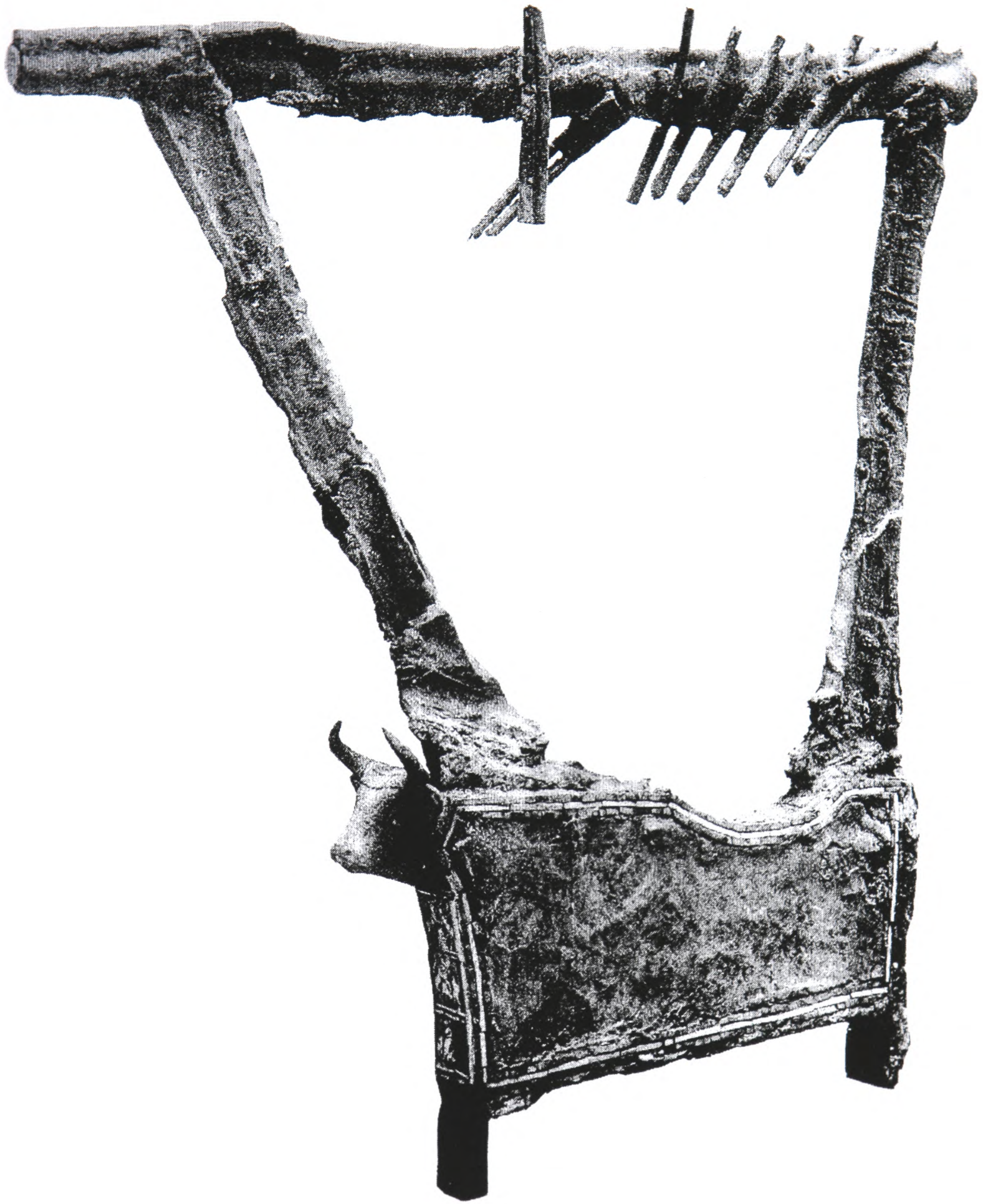


Fig.133



Fig.134



Fig.135



Fig.136



Fig.137



Fig.138



Fig.139



Fig.140



Fig.141

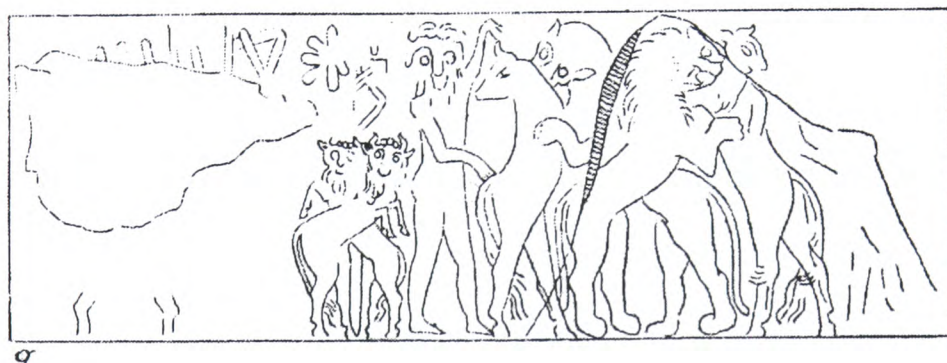


Fig.142



Fig.143

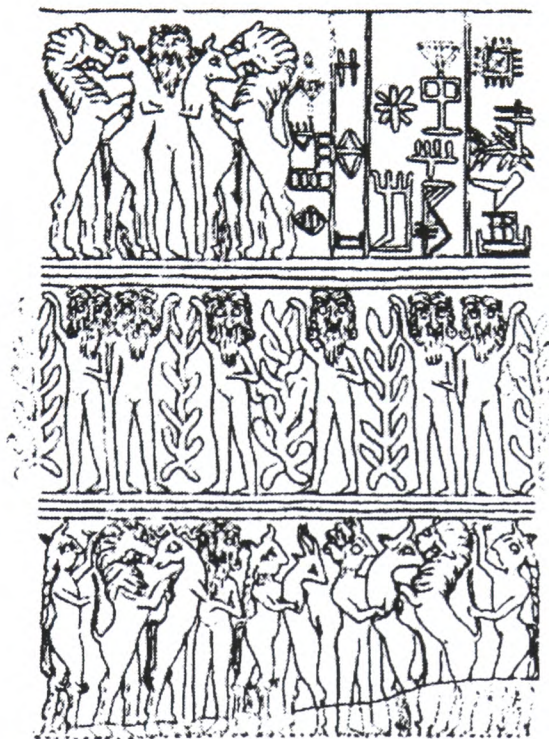


Fig.144

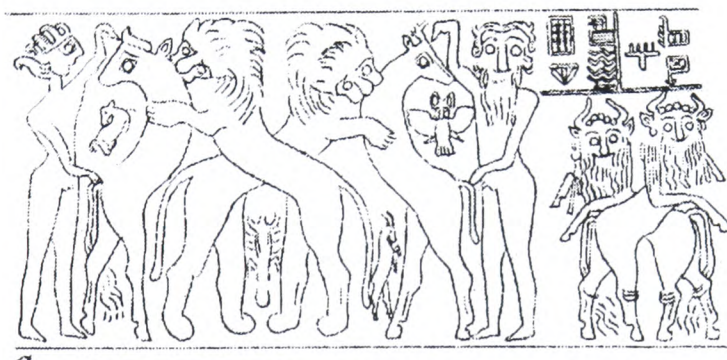


Fig.145

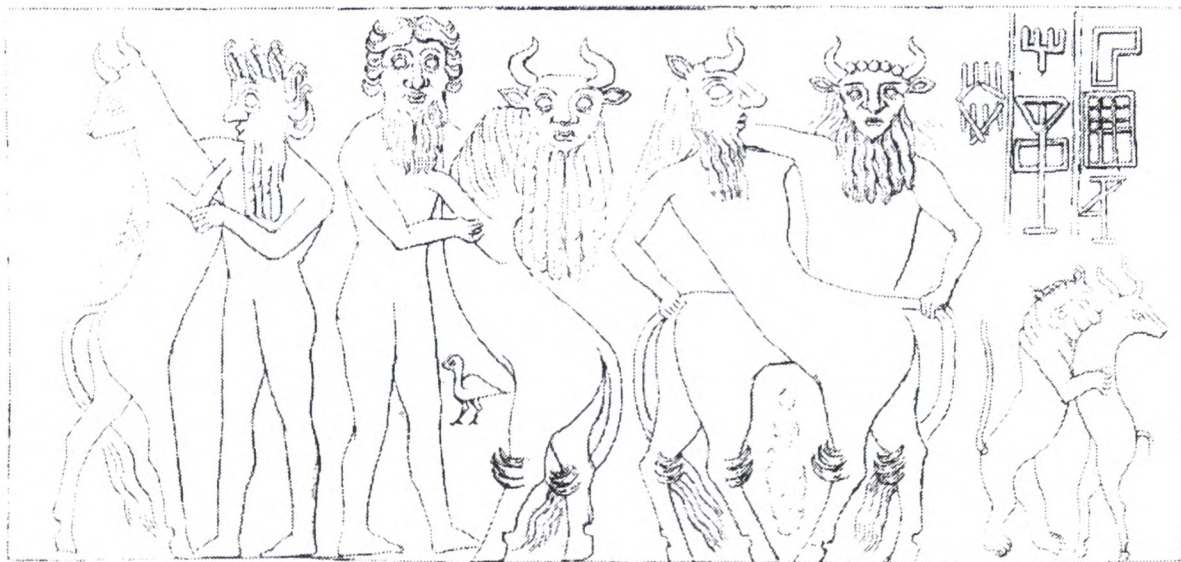


Fig.146

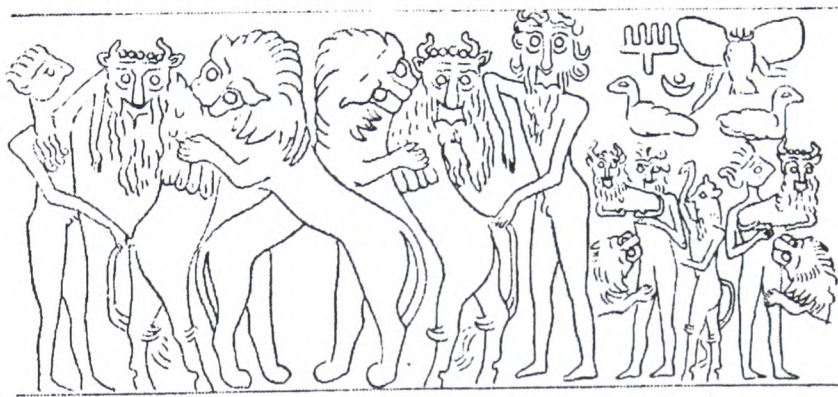


Fig.147

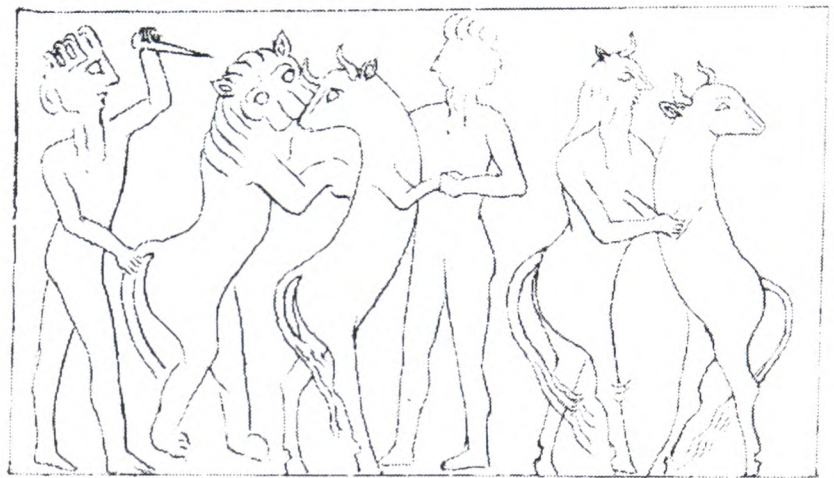


Fig.148

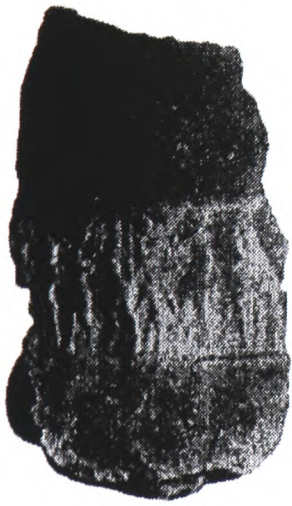


Fig.149

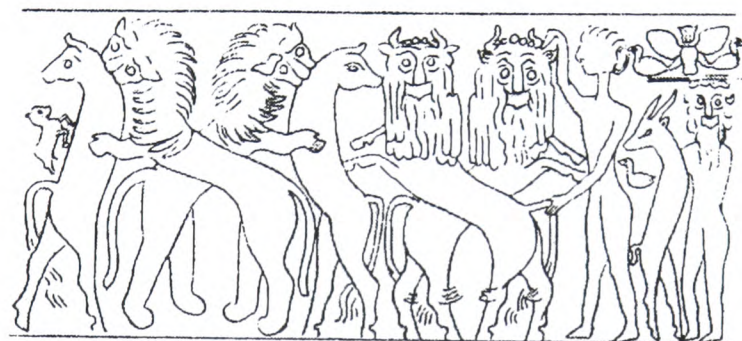


Fig.150

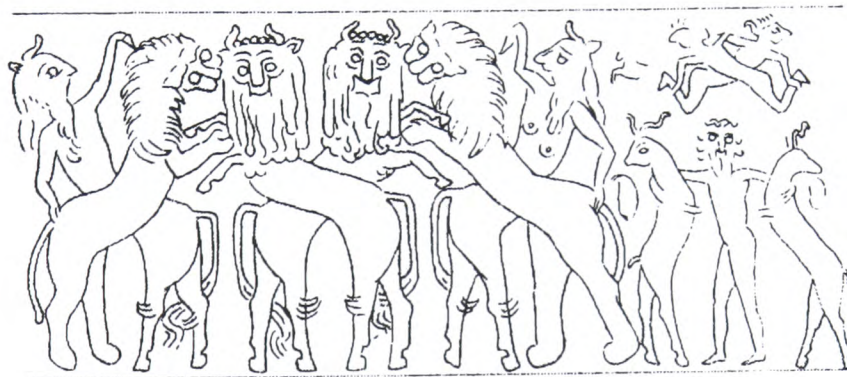


Fig.151



Fig.152

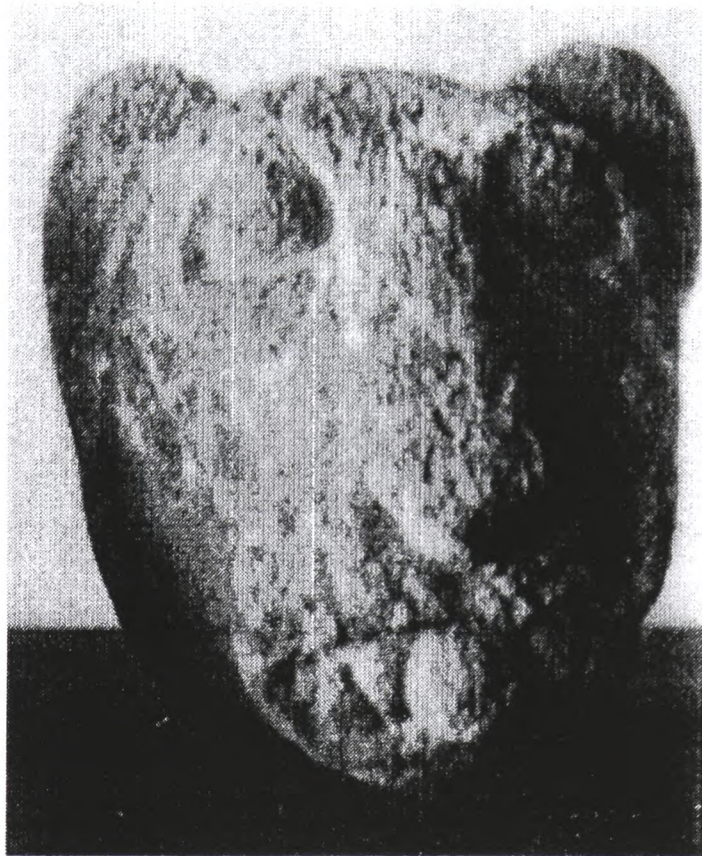
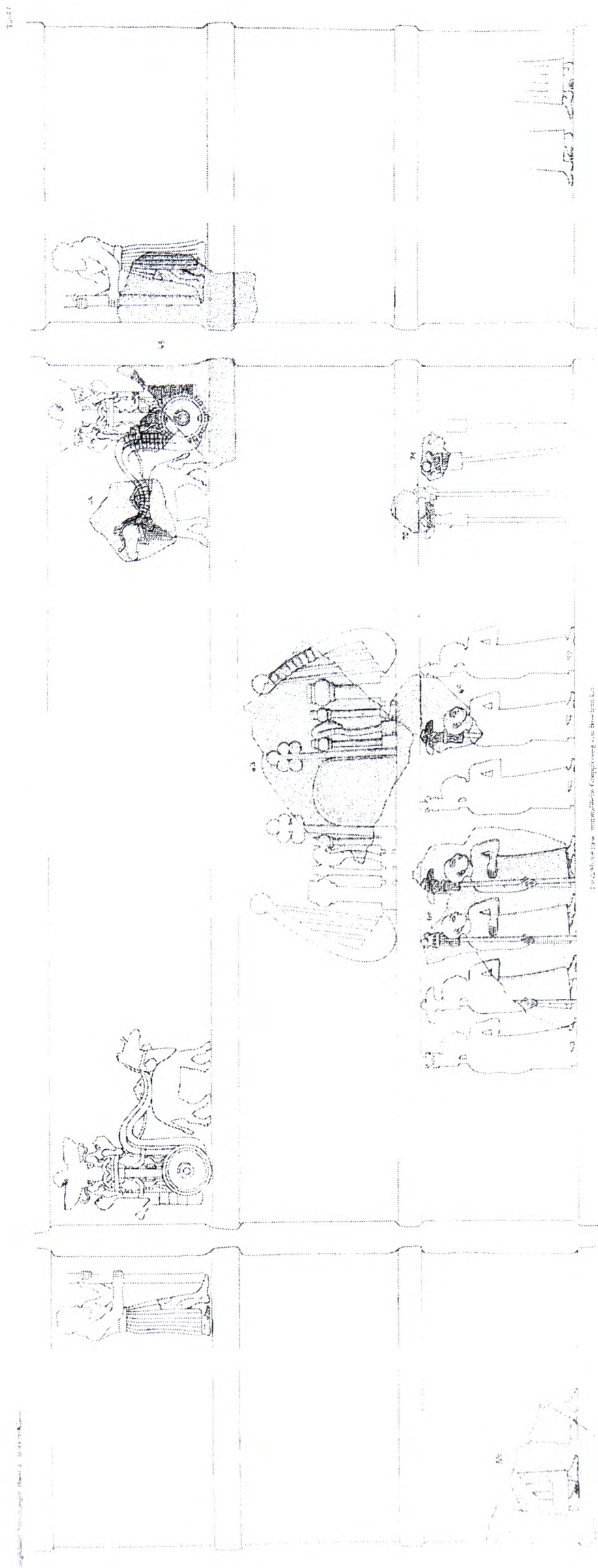


Fig.153



Copyright © 2000 by The McGraw-Hill Companies, Inc.

Fig.154

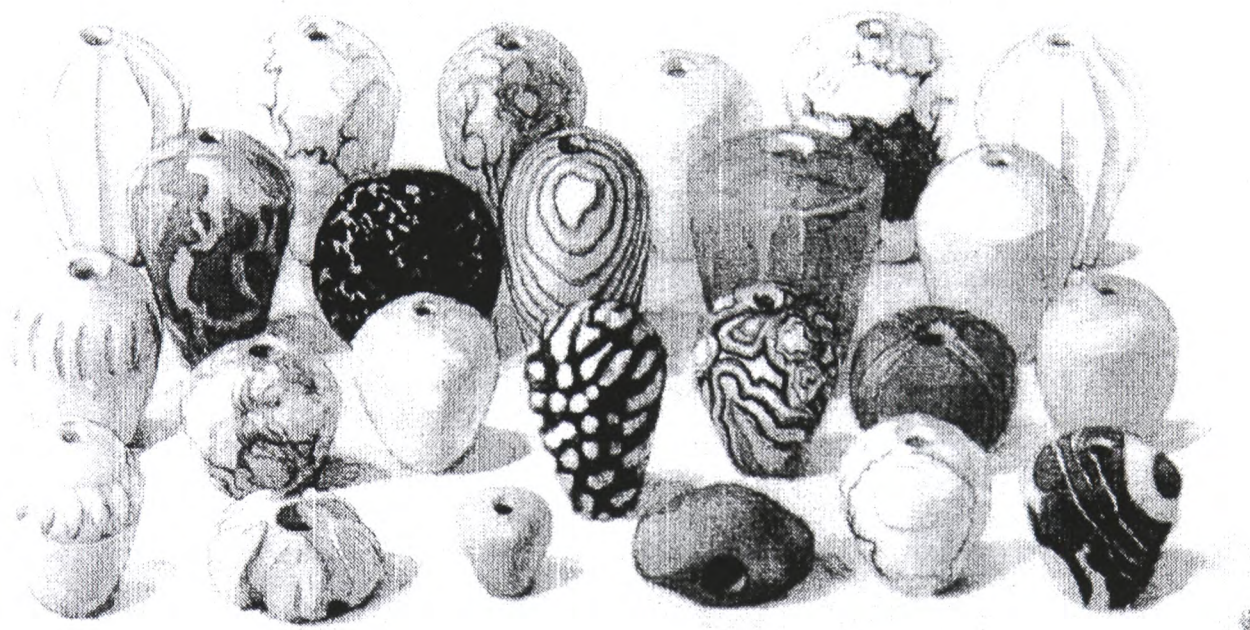


Fig.155



Fig.156



Fig.157



Fig.158



Fig.159



Fig.160



Fig.161



Fig.162



Fig.163



Fig.164



Fig.165



Fig.166



Fig.167

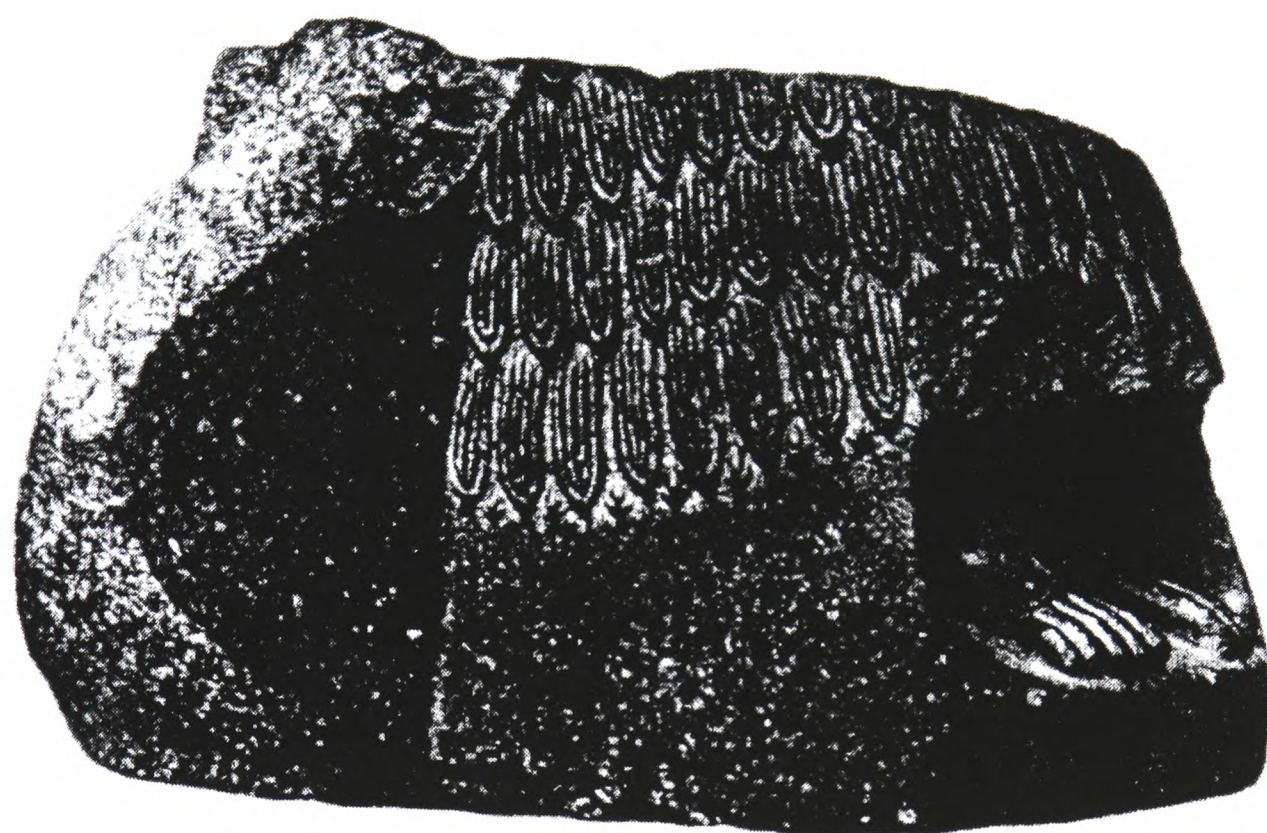


Fig.168



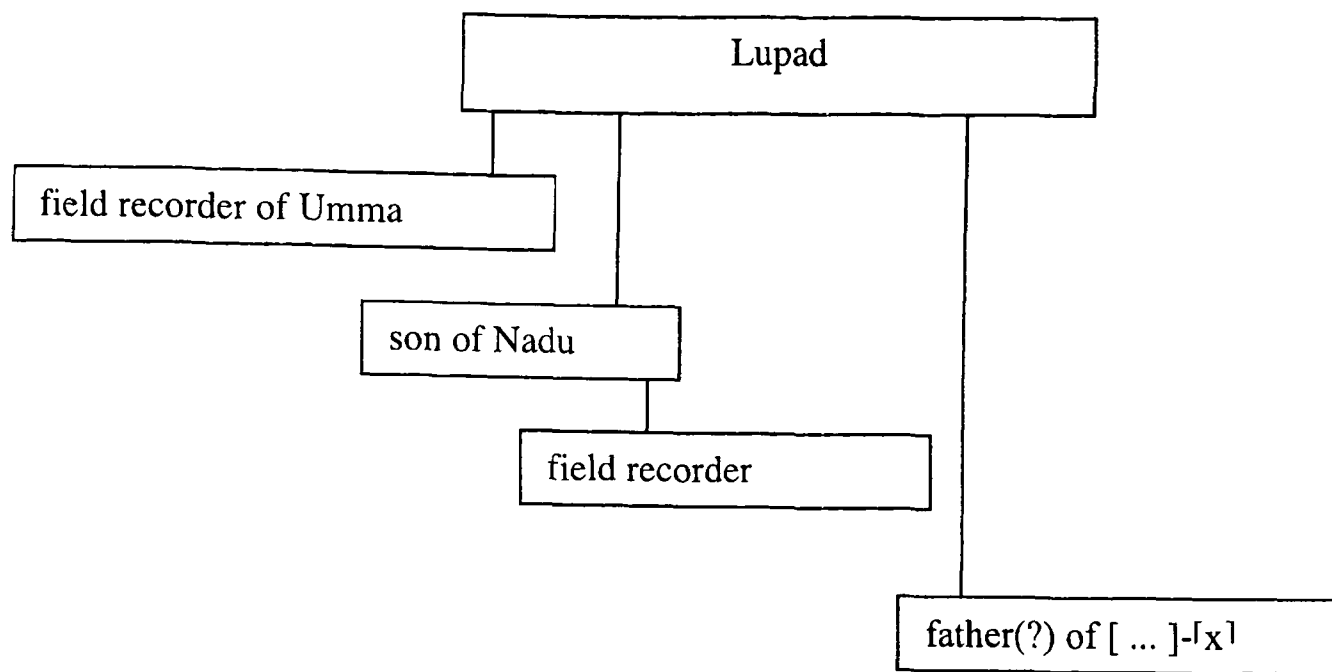
Schriftstufen	? (Adab)	Lagaš	Umma	Ur	Kiš	Nippur	Mari	Hafāgi			Stilstufen	
								Tell Asmar	Tempel oval	Nintu-Tempel		Sin-Tempel
I a	Ušumgal		Enlilpabilgagi		Emmebaragesi	7N-202 7N-171	Sar-II	Square Temple I		V	VIII	I a
I b		Rundbasis				7N-137 7N-136 + 155	Tagge		I			I b
2600											IX <sub>1</sub>	
II Zeit der Fara-Tafeln		Lugal-šaengur Enhegal	E. Abzu		Mesilim		Apih-II			VI	Urkisala	II a
II/III 2490-2455	Dudu	Urnanše		Königsgräber			Ikun-Samagan	III			IX <sub>5</sub>	II b
III		Akurgal		I. Dynastie								
		Eanatum							II			III
		Enanatum I								VII		
		Entemena							III			
		Enanatum II										
		Enentarzi	Lugalzagesi	Lugal-kisalsi								
		Lugalanda										
		Urukagina										
Sargon 2340-2284	Lugaldalu DI.UTU Meskigala						Lamgi-Mari					

Tabelle 2: Einteilung der Steinschriften und Statuetten in Schrift- und Stilstufen.

..... Schriftstufen  
 --- Stilstufen

Two possibilities for defining identity via nested category relationships  
in the Lupad inscription

A.



B.

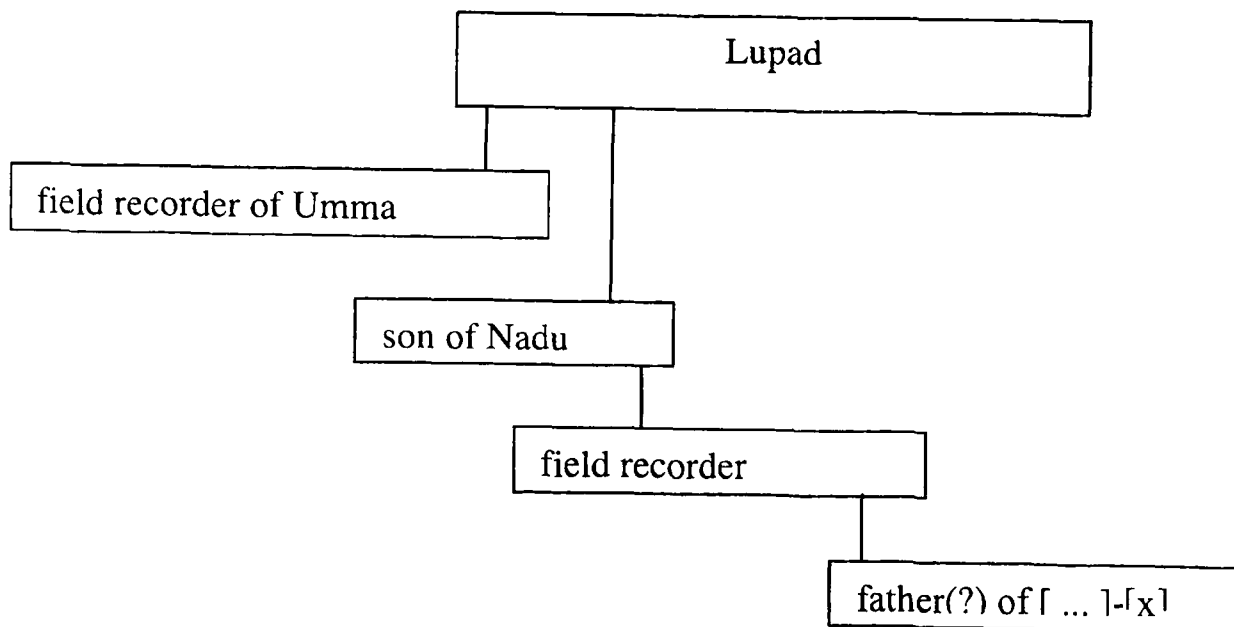


Fig.171



Fig.172



Fig.173



Fig.174



Fig.175



Fig.176

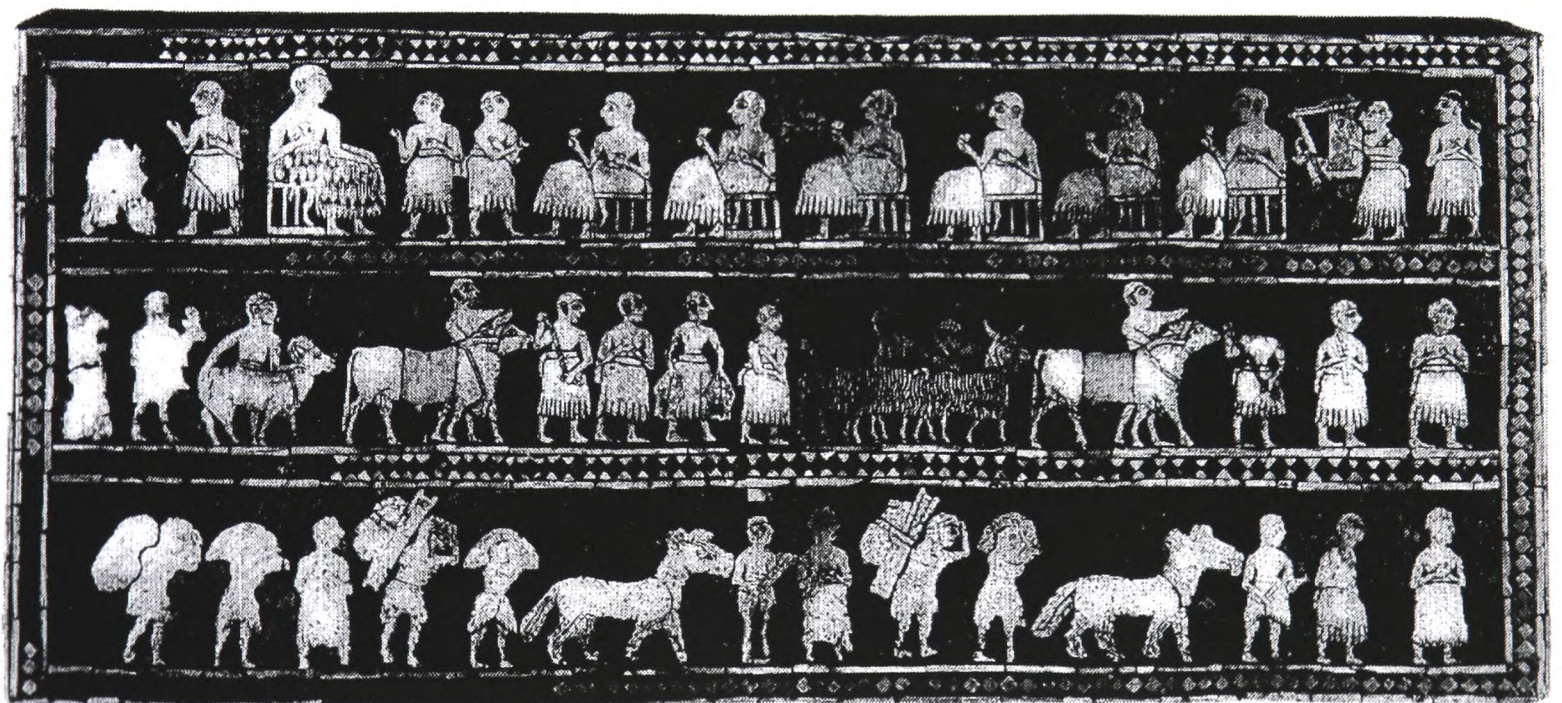
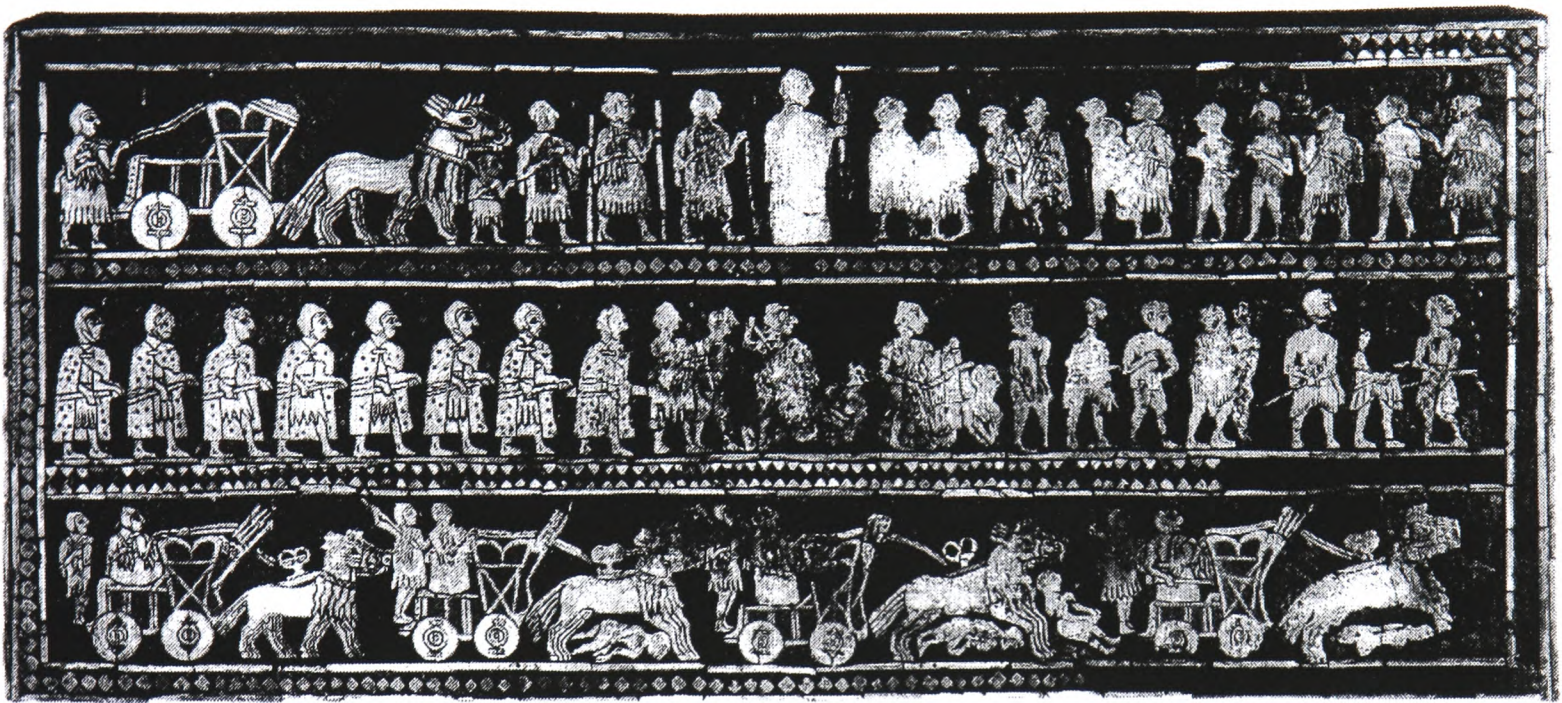
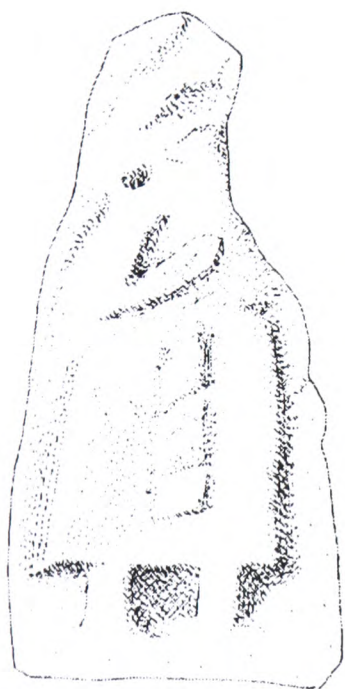


Fig.177

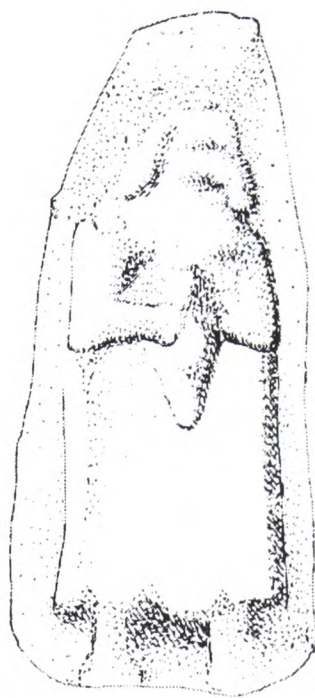


Fig.178





RECHTE SCHMALSEITE



LINKE SCHMALSEITE



VORDERSEITE

Fig.180



Fig.181



Fig.182



Fig.183



Fig.184



Fig.185

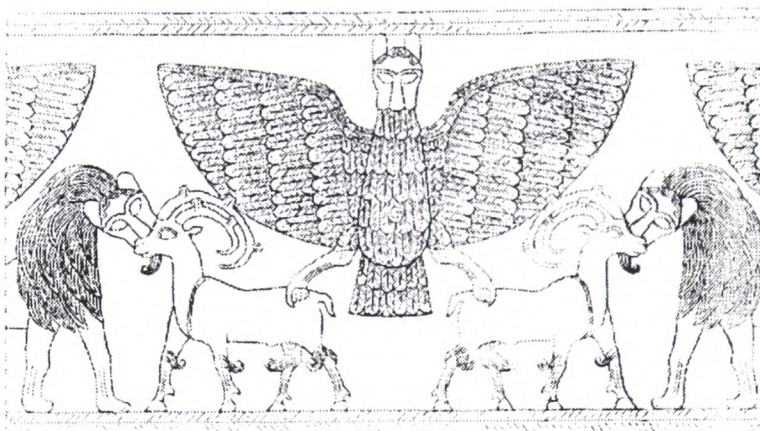
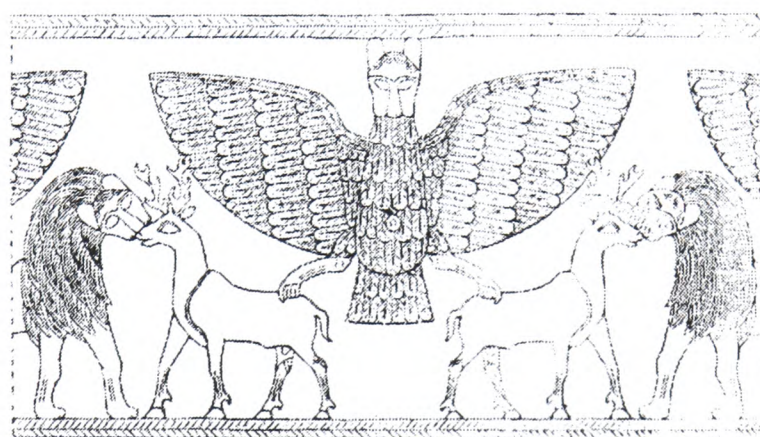


Fig.186



Fig.187



Fig.188



Fig.189

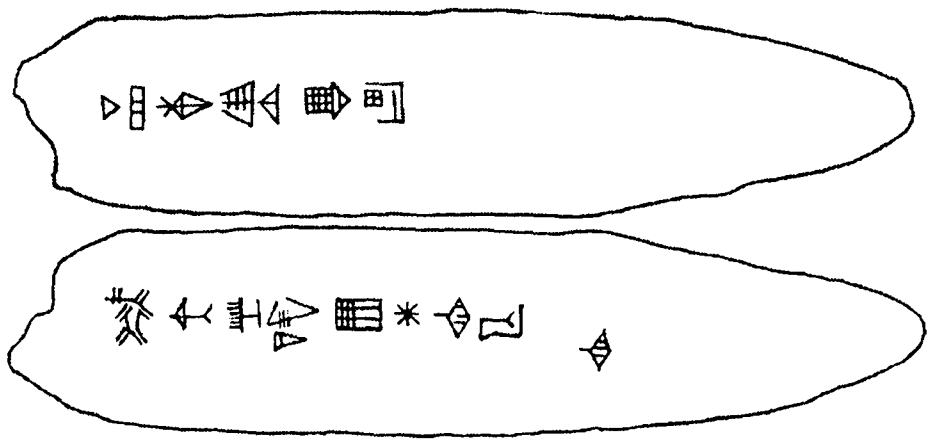


Fig.190



Fig.191



Fig.192



Fig.193



Fig.194



Fig.195



Fig.196



Fig.197



Fig.198



Fig.199

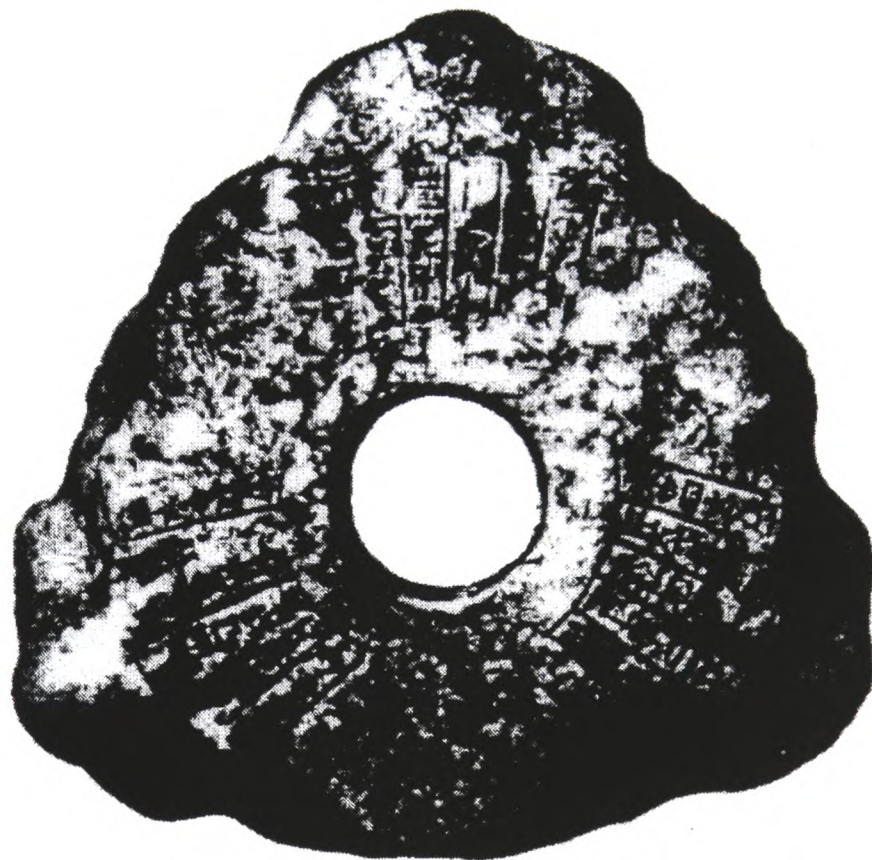


Fig200

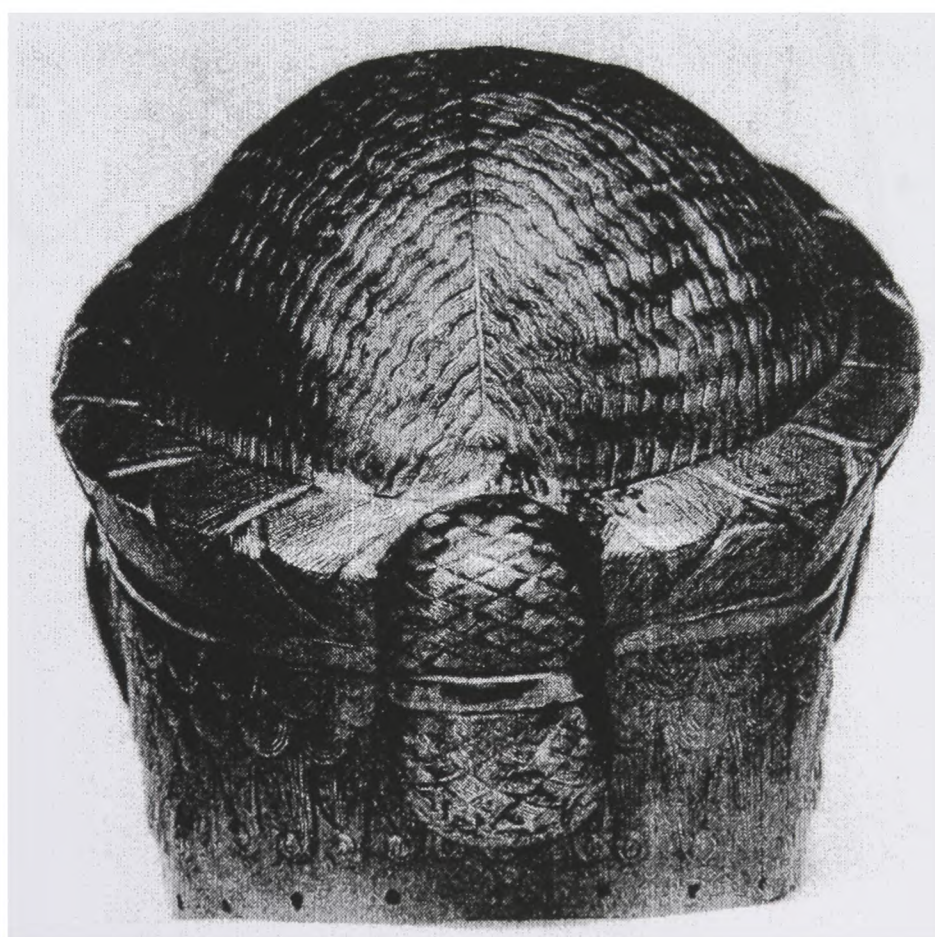


Fig201

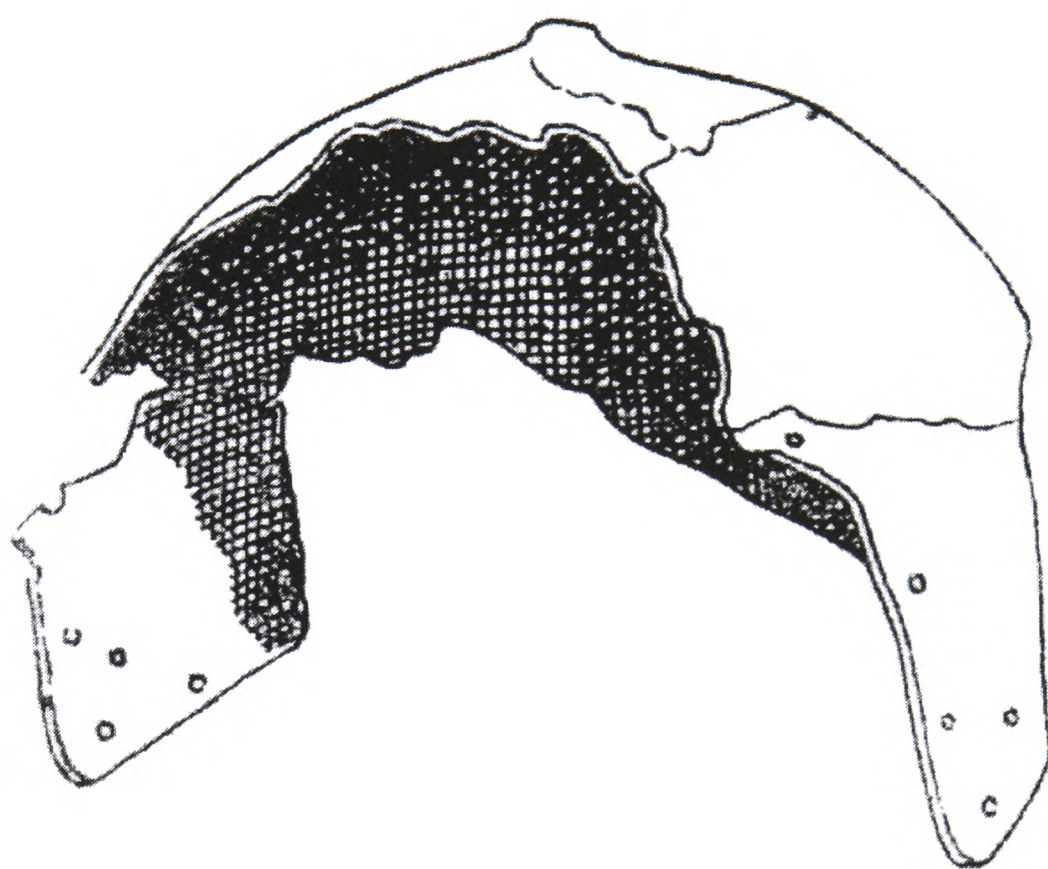


Fig202

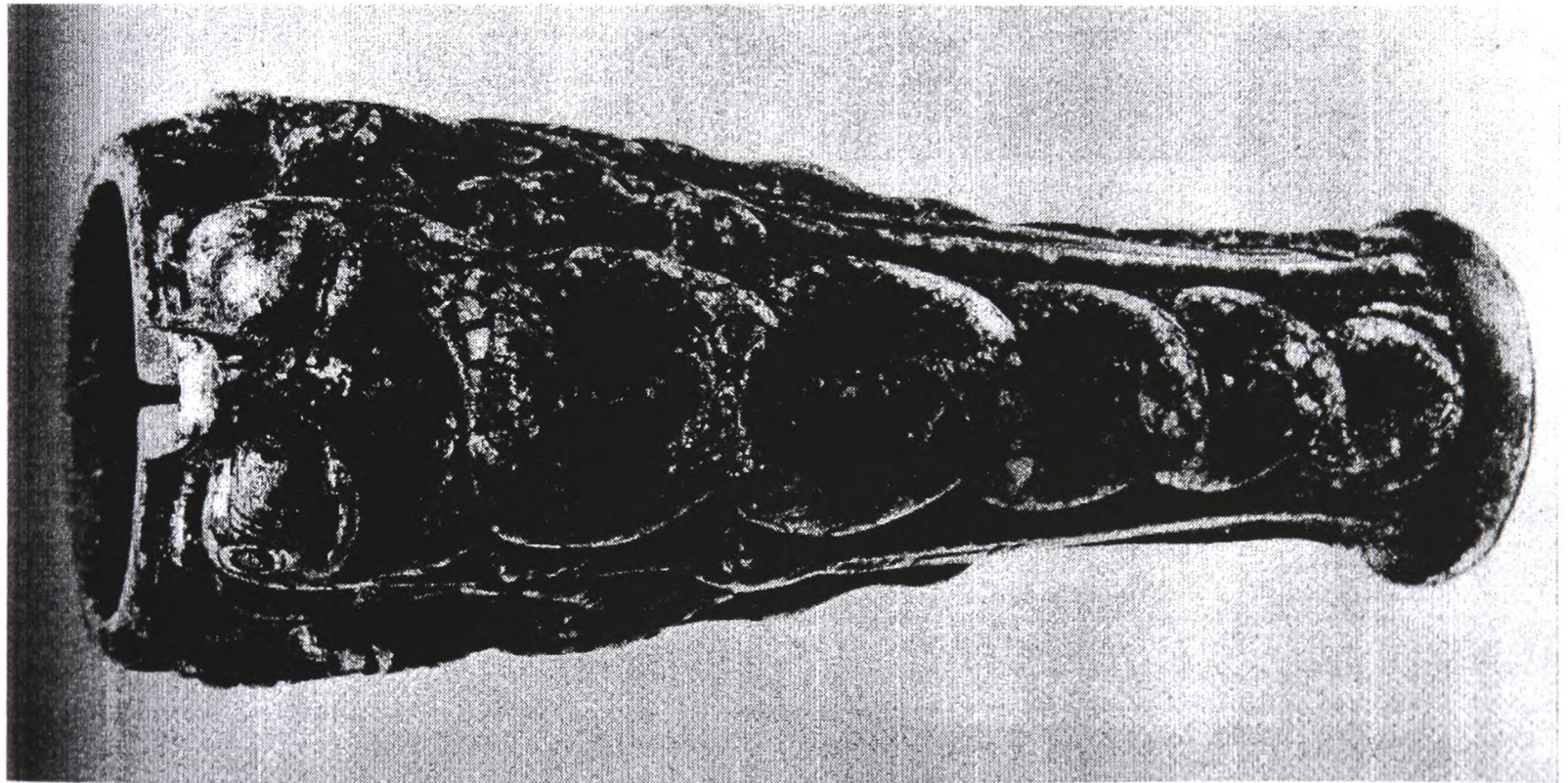
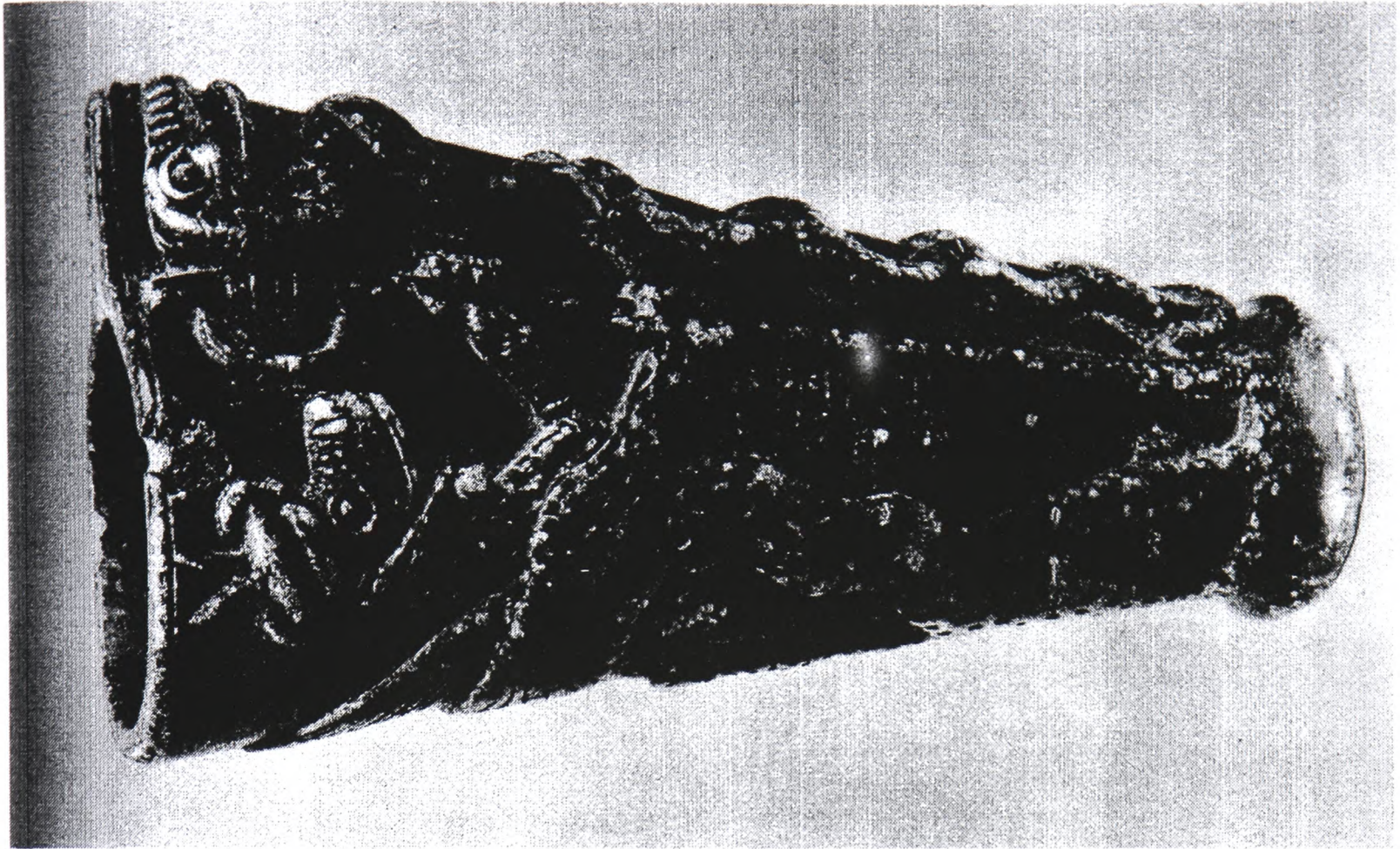


Fig203



Fig204



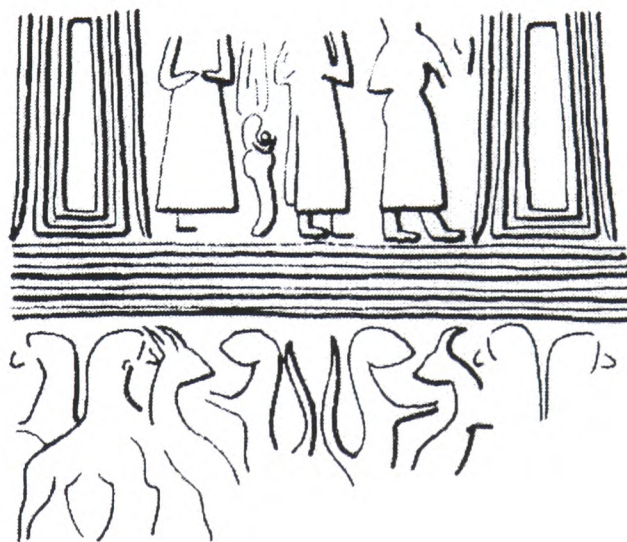










Fig210



Fig211



Fig212



Fig213

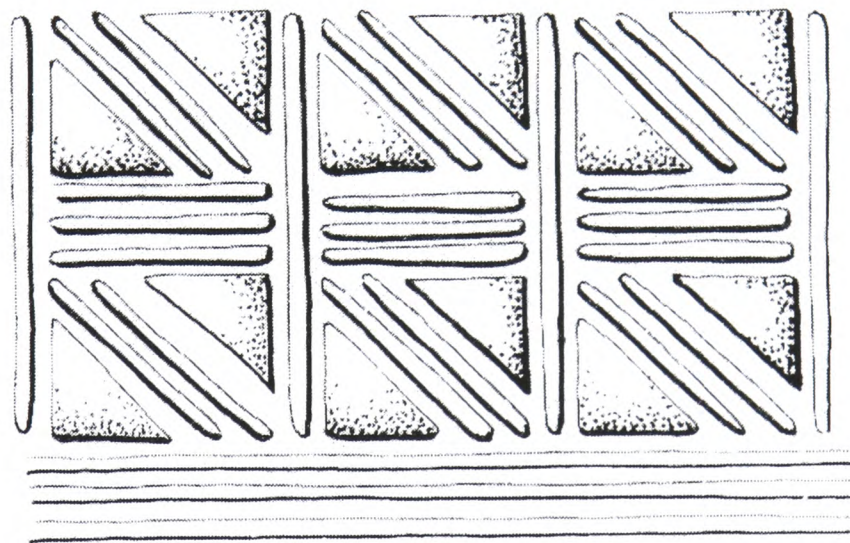


Fig214

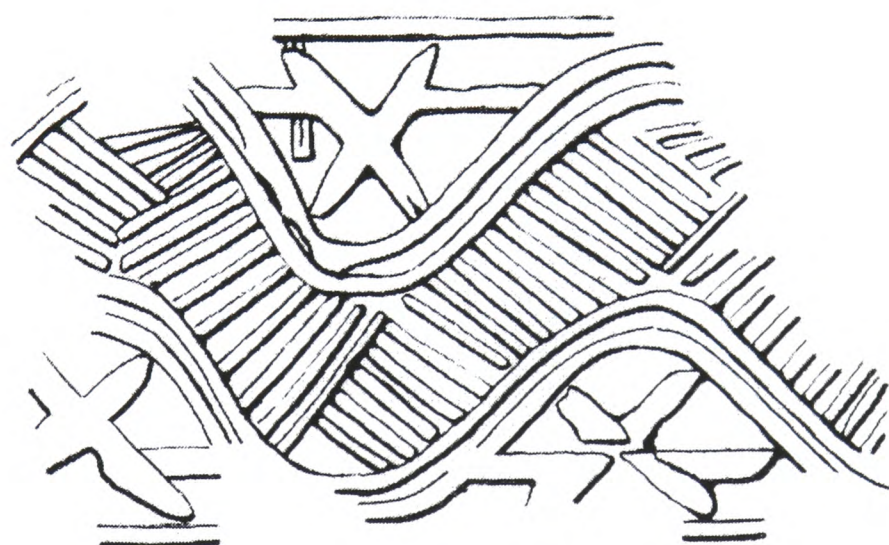


Fig215



