

STUDIES IN PEPTIDE CHEMISTRY.

A THESIS SUBMITTED TO THE BOARD OF
THE FACULTY OF PHYSICAL SCIENCES FOR THE
DEGREE OF DOCTOR OF PHILOSOPHY



BY

DAVID WILLIAM THOMAS

ST JOHNS COLLEGE &

DYSON PERRINS LABORATORY

UNIVERSITY OF OXFORD

OCTOBER 1988

ABSTRACT.

STUDIES IN PEPTIDE CHEMISTRY.

D.W.THOMAS. ST. JOHNS COLLEGE.

A THESIS SUBMITTED FOR THE DEGREE OF D.PHIL. MICHAELMAS

TERM 1988.

The thesis discusses the design of potential inhibitors of Angiotensin Converting Enzyme (ACE). The synthesis of peptide inhibitors containing arginine and histidine-type residues is described. Successful incorporation of these residues during peptide synthesis requires the use of protecting groups on the side-chains, and new developments in this area are described.

Ch. 1 reviews the currently available protecting groups for histidine. A methodology for regiospecific introduction of protecting groups of type $ROCH_2-$, via their corresponding chloromethyl ethers, is described. A convenient synthesis of these reagents (specifically t-Butoxymethylchloride, Bum-Cl and 2,4,6-Trimethylbenzyloxymethylchloride, Tom-Cl) is given.

Ch. 2 demonstrates that a knowledge of the location of histidine protecting groups has become mandatory, both in peptide synthesis and elsewhere. Two methods, a), nuclear Overhauser enhancement measurements and b), a procedure involving methylation, deprotection and amino-acid analysis are presented, which have allowed the differentiation of π and τ derivatised histidines.

Ch. 3 reviews the currently available protecting groups for arginine. Using 2-phenylethylguanidine as a model for arginine, a number of haloacylguanidines and 5,5-disubstituted pyrimidinones were synthesised, and this chapter describes their structures, and the potential use of the corresponding reagents in protecting arginine during peptide synthesis.

Ch. 4 describes the synthesis of histidylphenylalanylarginine and several variants on this structure. Biological data showing the level of inhibition both of A.C.E. and of Renal Endopeptidase by these compounds is presented. The syntheses also provide a further demonstration of the efficacy of the recently introduced benzyloxymethyl, (Bom) protecting group.

TO MY PARENTS

And now (Dorothea) pictured to herself the days, and months, and years which she must spend in sorting what might be called shattered mummies, and fragments of a tradition which was itself a mosaic wrought from crushed ruins:- sorting them as food for a theory which was already withered in the birth like an elfin child. Doubtless a vigorous error vigorously pursued has kept the embryos of truth a-breathing; the quest of gold being at the same time a questioning of substances, the body of chemistry is prepared for its soul, and Lavoisier is born. But Mr Casaubon's theory of the elements..... was as free from interruption as a plan for threading the stars together.

GEORGE ELIOT

Middlemarch (1872), Bk. 5, Ch. 48.

ACKNOWLEDGEMENTS.

I wish to record my sincere thanks to Dr. J. H. Jones for his continual guidance during the course of this work, and to Dr. R. Kobylecki of Pfizer for helpful discussions and assistance.

I would also like to thank the staff of the Dyson Perrins Laboratory, and in particular Mr. A. Howe for coaxing our ageing analyser into action, and Mrs Elizabeth Mc Guinness for her unstinting efforts with the 300 MHz spectrometer.

The work was made possible by funding from the S.E.R.C., in collaboration with Pfizer Central Research (Sandwich) through a C.A.S.E. studentship.

Help and companionship from my colleagues made my time in the Perkin Laboratory very pleasant, and in particular I should like to mention Dan Rathbone, Dave Freyer and Peter Wyatt.

I utterly reject the modern trend that equates education only with a knowledge of technical minutiae. In this respect I am most grateful during my time in Oxford to Rev. Dr. Margaret Yee, Canon Dr. A.C.J. Phillips, Dr. Michael Goldsmith and Dr. Neil Allan, for discussions at a higher level.

Special thanks are due to my Mother for typing this thesis.



ABBREVIATIONS.

Ac	Acetyl.	D.E.M.	Diethyl-
A.C.E.	Angiotensin		Malonate.
	Converting	Dioxan	1,4-Dioxan.
	Enzyme.	dist.	Distorted.
Ang.	Angiotensin.	DMF	N,N-Dimethyl-
Ar	Aromatic.		formamide.
b	Broad.	DMSO	Dimethylsul-
B:	Base.		phoxide.
Boc	t-Butoxy-	Dnp	2,4-Dinitro-
	carbonyl.		phenyl.
Bom	Benzyloxy-	E.I.	Electron Impact.
	methyl.	Et	Ethyl.
B.p.	Boiling point	Ex	Exchanges with D ₂ O.
	(uncorrected).	F.A.B.	Fast Atom Bombard-
Bum	t-Butoxymethyl.		ment.
Bzl	Benzyl.	F.D.	Field Desorption.
C.I.	Chemical	Fmoc	9-Fluorenylmethoxy-
	Ionization.		carbonyl.
d	Doublet.	G.C.M.S.	Gas-Chromatography/
DCCI	Dicyclohexylcar-		Mass Spectroscopy.
	bodiimide.	G.l.c.	Gas-liquid chromato-
DCHA	Dicyclohexyl-		graphy.
	amine.	HOBt	1-Hydroxybenzotri-
DCU	Dicyclohexyl-		azole.
	urea.	I.C ₅₀	Concentration giving
dec	Decomposes.		50% inhibition.
dec→	Proton-decoupled to.	Im	Imidazole.

I.r.	Infra-red,	Pyrim.	Pyrimidyl.
Irr	Irradiation.	q.	Quartet.
m	Multiplet.	quin.	Quintet.
Mem	Methoxyethoxy-	R	Alkyl.
	methyl.	RT	Room Temperature,
molyb.	Dodecamolybdo-		(approx 20°C).
	phosphate.	s.	Singlet.
M.p.	Melting point	Sem	Trimethylsilylethoxy-
	(uncorrected).		methyl.
m.s.	Mass spectros-	t.	Triplet.
	copy.	Tcp	2,4,5-Trichlorophenyl.
N ^G	Substitution on	TFA	Trifluoroacetic acid.
	guanidine nitrogen.	TFMSA	Trifluoromethanesul-
Nin.	Ninhydrin.		phonic acid.
N.m.r.	Nuclear magnetic	THF	Tetrahydrofuran.
	resonance.	T.l.c.	Thin layer chromatog-
N.O.e.	Nuclear Overhauser		raphy.
	enhancement.	Tom	2,4,6-Trimethylbenzyl-
Obsc.	Obscured.		oxymethyl.
Oct.	Octet.	Tos	4-Toluenesulphonyl.
ONSu	Succinimide ester.	Trt	Triphenylmethyl.
Pcp	Pentachlorophenyl.	v.	Very.
Ph	Phenyl.	Z	Benzyloxycarbonyl.
"pH"	Apparent pH on wet	All amino acids are of the L-configuration	
	indicator paper.	unless otherwise noted.	
Phen	Phenacyl.	THP	Tetrahydropyranyl.
Ppc	Piperidinocarbonyl.		
Pth	Phthaloyl.		

CONTENTS.

	Page No
<u>INTRODUCTION.</u>	1
<u>RESULTS AND DISCUSSION.</u>	
Chapter 1. Regiospecific Introduction of Acid-Labile Protecting Groups to the Imidazole moiety of Histidine.	12
Chapter 2. Differentiation between π and τ Derivatised Histidines.	29
Chapter 3. Investigations into the Protection of the Guanidine Function in Arginine.	50
Chapter 4. Preparation of some Imidazole and Guanidine containing Tripeptides as potential Angiotensin Converting Enzyme Inhibitors.	68
<u>EXPERIMENTAL.</u>	
Methods and Materials.	85
Chapter 5. Preparation of Reagents of the General Class ROCH_2Cl and their reaction with Histidine Derivatives.	87
Chapter 6. Nuclear Overhauser Measurements, and Methylation/Amino-Acid-Analysis of Histidine Derivatives.	104
Chapter 7. Preparation of Haloacyl and Pyrimidine Derivatives of Compounds containing the Guanidine Function.	121
Chapter 8. Preparation of Histidylphenylalanylarginine and Modifications thereof.	135
<u>REFERENCES.</u>	155

INTRODUCTION.

INTRODUCTION.

Broadly speaking, pharmacological intervention in therapeutics has until comparatively recently had recourse to two general classes of drug. Firstly those derived from natural products by extractive methods, and secondly a set of diverse but comparatively simple synthetic compounds. The former group of materials include such as the terramycins and penicillins, where chance together with sound systematic work¹ have played the dominant role in their discovery; the element of design was completely lacking. Even today work on the synthesis of this class of compound, though often technically brilliant, still lacks an element of design. It must therefore be assumed that work will continue steadily but unspectacularly in this area. The more diverse group of compounds mentioned above has been developed to mimic a variety of small molecules in the body. They do not in themselves fall into any particular category, but examples might include the neurotransmitters, or the various simple intermediates present on the body's metabolic pathways.

If work were to be confined to expanding either of these classes of pharmaceuticals, it would be a neglecting of the fact that the majority of operations taking place within the body, and indeed the assembly of the fabric of the body, are under enzymatic control. This consideration gives rise to a third class of potential drugs, those mimicing some aspects of the enzymes and their co-factors. Their early development naturally becomes the province of the peptide and protein chemist.

The business of "designing drugs to fit a macromolecular receptor", such as an enzyme, has become important in most institutions with an interest in new pharmaceutical development. the area, though

comparatively new, has been extensively reviewed; indeed the above quote forms the title of an excellent review by Beddell².

Obviously a good starting point in the design is a knowledge of the receptor itself; ideally one should try to perform some receptor structuring, that is direct determination of morphological structure using physical probes. X-ray crystallography and more recently nuclear magnetic resonance spectroscopy have been especially useful in this regard. Unfortunately such clear information is not always available, as discussed below in relation to the enzyme of interest to us. However in this circumstance all is not lost as another technique is available termed receptor mapping. Here the receptor is challenged with a number of small molecular probes, and the receptor model is adjusted to agree with the experimental results, available principally in the form of binding constants. When sufficient data is obtained one may move on to the more skillful process of receptor fitting, that is adjusting the smaller molecules to fit the receptor. It is this latter process that we have attempted, and which is described in chapter four. To push the argument to its conclusion, once the fit is obtained the molecule may be modified to obtain agonistic or antagonistic responses from the system in which the enzyme is enmeshed, or to obtain specificity, or even some totally unrelated property such as solubility. One has then obtained a potential drug.

Work on the angiotensin converting enzyme (conventionally abbreviated to ACE), forms the subject of the latter part of this thesis; it was chosen for study for a number of reasons, but principally because of its significance at the center of the renin-angiotensin-bradykinin system of blood pressure regulation

(Fig.1). Additional factors encouraging the work are the huge scale of the hypertension problem in Western society and the potential rewards for its successful control, and also the amount already known about the tolerance of the enzyme towards various substrates.

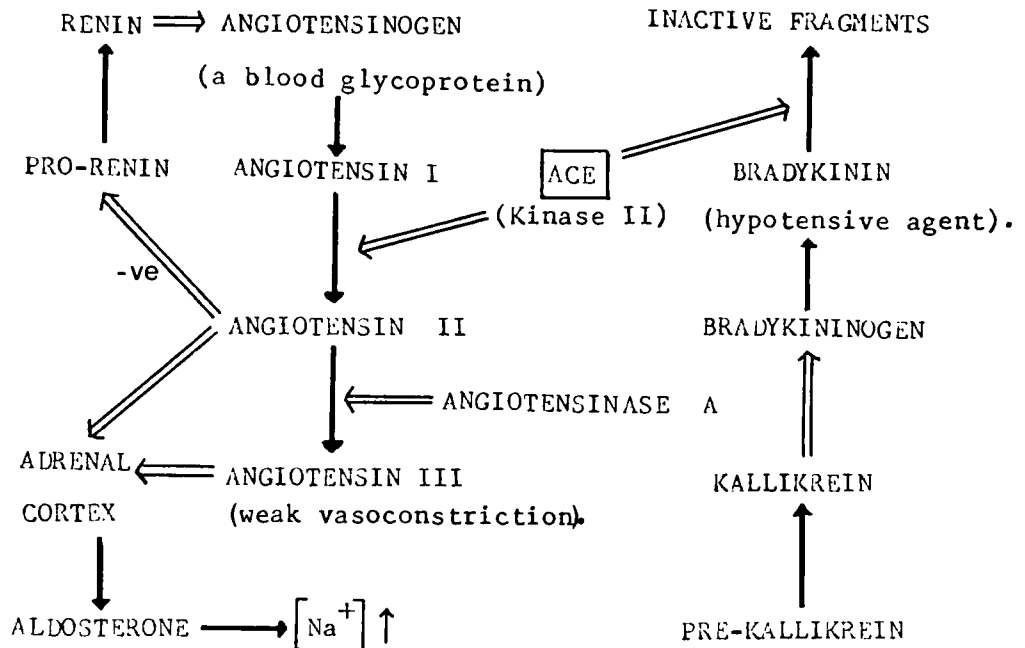

Fig.1.

Produces \longrightarrow Acts upon \Rightarrow

As can be seen from the figure, inhibition of the exopeptidase activity of ACE will lead to a double advantage with respect to the lowering of blood pressure, arising from its action both in the conversion of bradykinin to inactive fragments and angiotensin I to angiotensin II. This advantage is not shared by inhibition attempts on any other of the enzymes, and though in fact interference in the action of renin has been attempted, it is not our concern here.

Angiotensins I, II and III are all small peptides with known primary

structures, and the action of the various peptidases upon them is well understood (Fig.2), giving the first clues to their substrate requirements. Looking more closely at the action of ACE, it can be seen that this exopeptidase can be more accurately described as a peptidyl dipeptide carboxy-hydrolase. It is upon this type of information that one is forced to rely, for as mentioned above, detailed physical information on ACE is lacking. The known facts about its structure are summarised in the detailed review by Cushman and Ondetti³. These authors describe it as a membrane-bound glycoprotein with a somewhat animal-species-dependent molecular weight of between 129,000 and 140,000, consisting of a single polypeptide chain (except perhaps in the case of the hog). It is a zinc containing metalloenzyme, and the importance of the zinc is clearly demonstrated by the complete loss of activity brought about by sequestering it using metal chelating agents, and the subsequent restoration of activity by treatment with zinc (or cobalt) ions⁴. In this respect it resembles the action of carboxypeptidase A about which more is known. In this enzyme a positively charged group (Arg 145) forms an ionic bond with the C-terminal carboxyl group of its peptide substrate, and an adjacent hydrophobic pocket

Fig.2. .

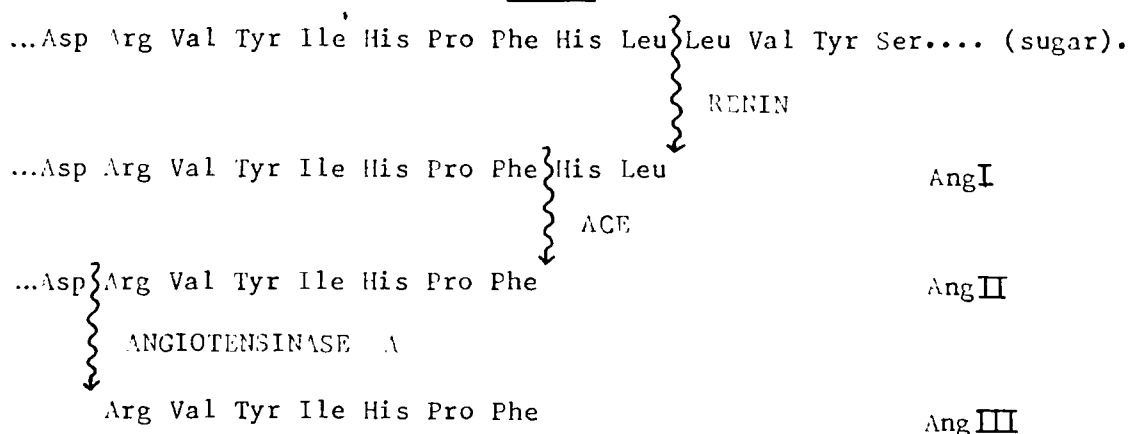

interacts strongly with the substrate via the side-chain of its terminal hydrophobic amino-acid; for which carboxypeptidase A is reasonably selective. The tightly bound zinc ion of carboxypeptidase A interacts with the carbonyl of the scissile peptide bond of the substrate and facilitates hydrolysis of this bond (Fig.3). More detailed schema of the proposed reaction site have appeared very recently.

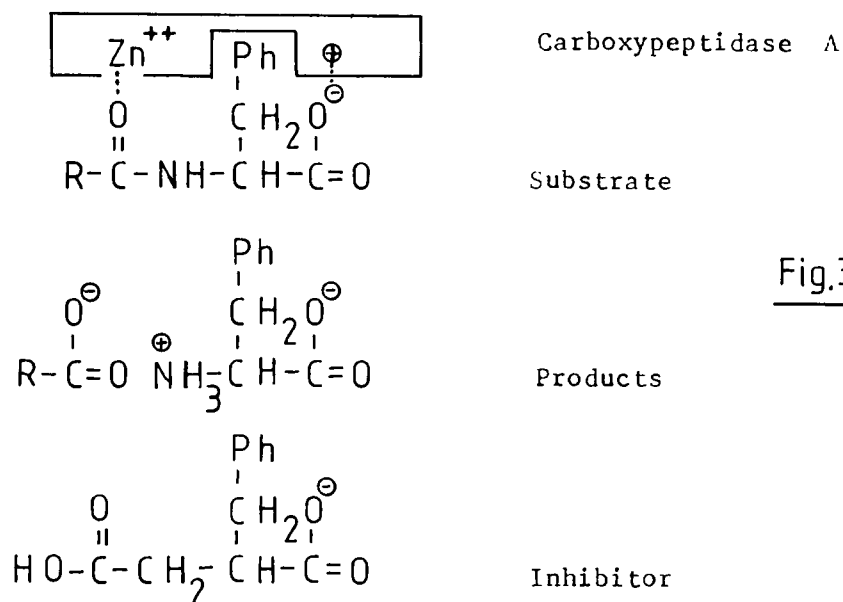
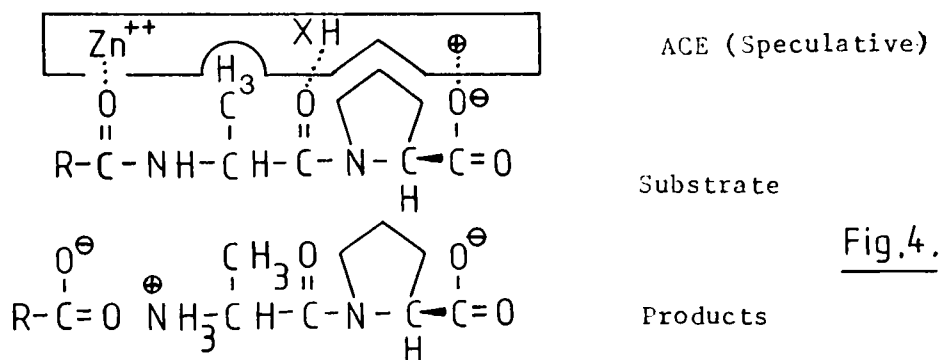

Fig.3.

It is hardly unreasonable to suppose that the active site of ACE is analogous to that found in carboxypeptidase A, still less to assume the zinc atom is intimately involved at the site of action. Indeed there is a general intuitive belief amongst protein chemists that as nature utilises metal ions for important functions e.g. catalysis, some mechanism resembling the above will be found to be the case in most metalloproteases. We concur with this thesis. One can thus speculate that the active site will resemble that shown here (Fig.4) for a substrate (BPP_{5a}) which has become a standard reference compound. As

can be seen in this figure, the distance between the carboxyl-binding group and the zinc ion was proposed to be greater than in carboxypeptidase A, so the zinc may participate in hydrolysis of the penultimate rather than the terminal peptide bond.



Following upon the above speculations, many workers set about preparing competitive inhibitors of ACE, designed to be by-product analogues. However it is of no value to retrace the development of these from the first inhibitor, succinyl proline, and the early structure-activity studies with snake-venom peptides, through to the first orally active compound 2-D-methylsuccinylproline⁶. These developments finally culminated in the preparation of the first clinically useful compound, captopril. The field has been fully reviewed to 1980³, and the essential compounds and derived information from these and others is described paucis verbis in the diagrams (Fig. 5 and 6). It is interesting to note that all five amino acid residues of BFP_{5a} are apparently important for full inhibitory activity, though the C-terminal tripeptide retains significant activity, thus enabling a distinction to be made between primary and auxiliary binding sites.

Between 1980 and the present, work has continued apace both in the further investigation of substrate specificity and in more physical

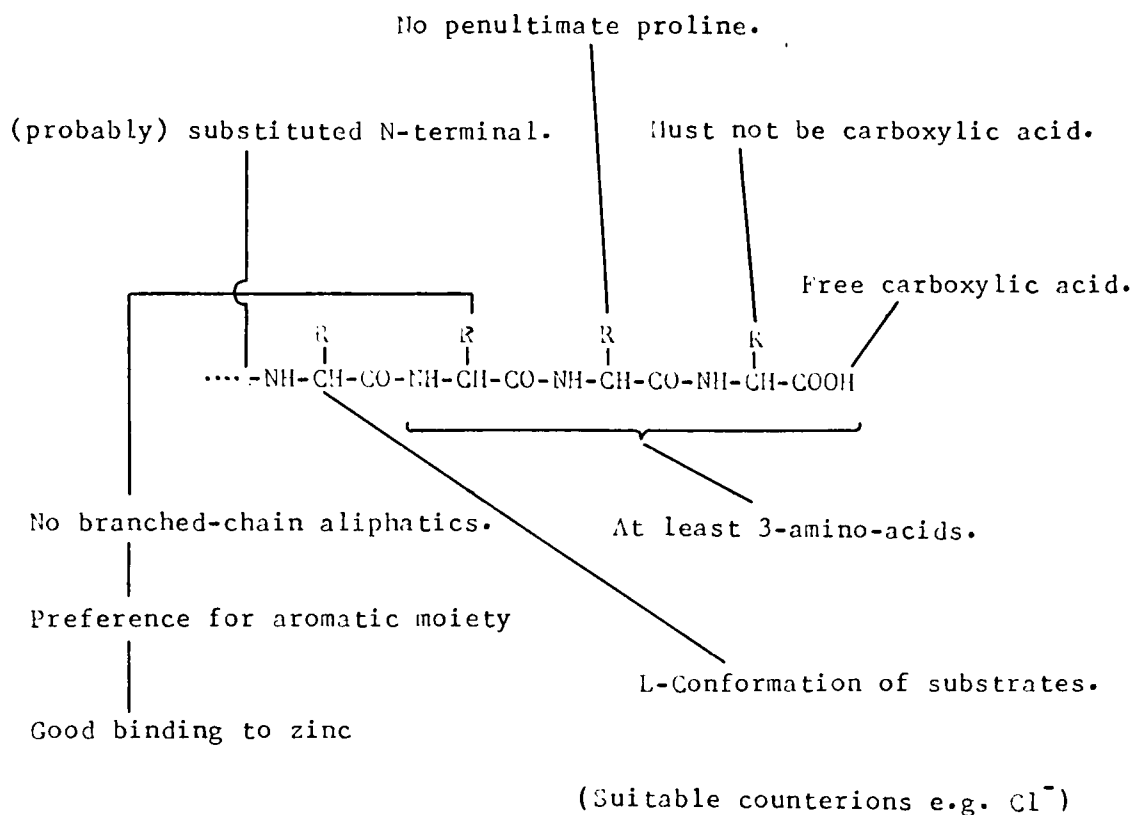
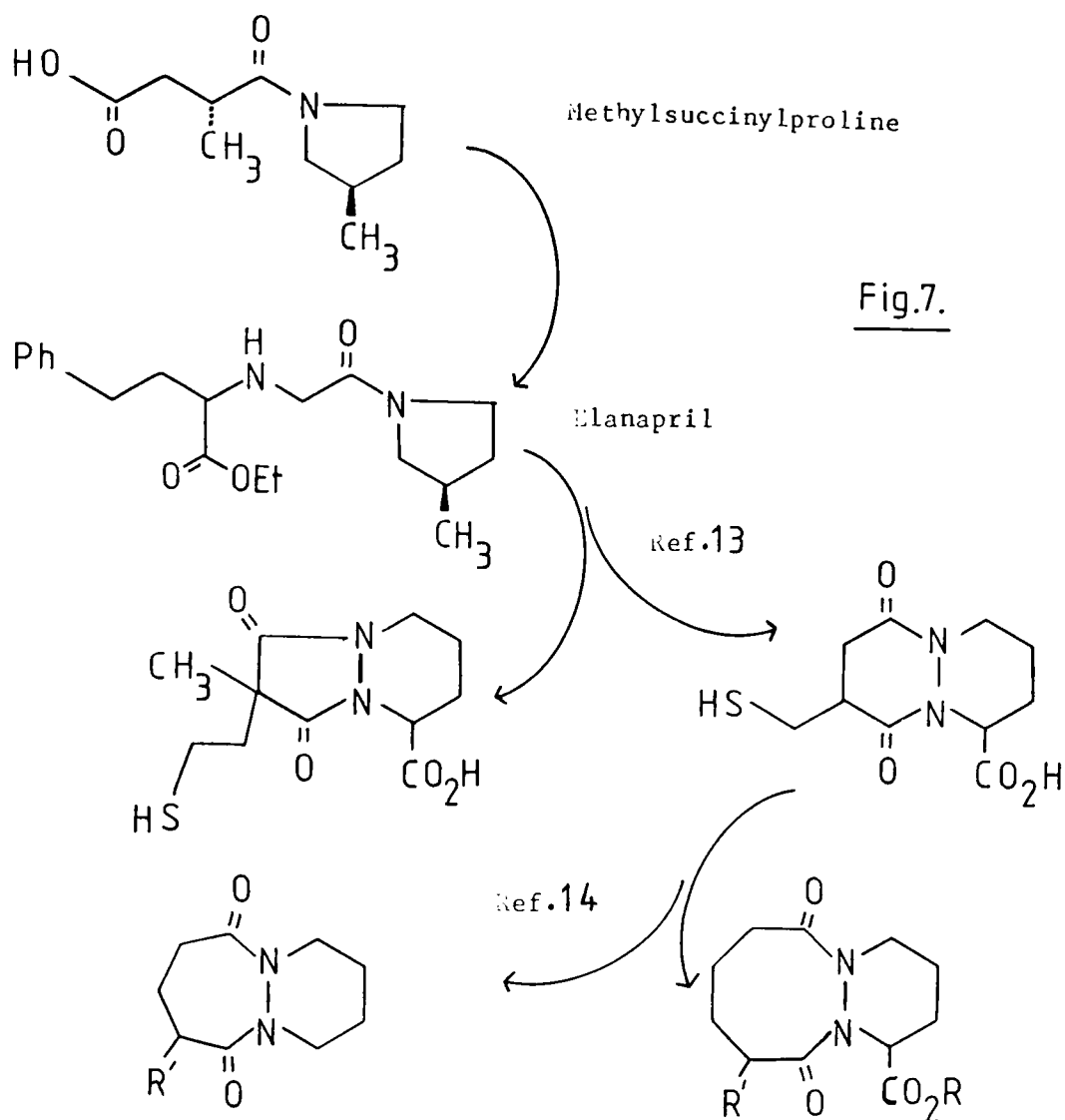

Fig.6. REQUIREMENTS FOR A GOOD ACE INHIBITOR

stored potential at angiotensin receptors may be responsible for driving the response mechanism". This may be taken as some justification of the initial target choice in chapter four.

The requirement for a C-terminal carboxyl function stimulated an attempt to replace it by other acidic functional groups (Almqvist *et al* 1985).⁹ These authors took a compound derived from BzPheGlyProOH (where the Gly nitrogen had been replaced by a methylene function), which had been previously shown to be a potent ACE inhibitor with poor in-vivo activity¹⁰ due to rapid excretion in the bile (an effect known to be related to the presence of the free carboxyl). Replacement by a phosphonic acid, hydroxamic acid or tetrazole moiety resulted in a



great reduction of ACE inhibitory activity and complete loss of in-vivo activity. This paper is representative, and illustrative of the problems which lie between obtaining an inhibitor and obtaining a useful drug. Even established drugs such as the previously mentioned captopril suffer from unpredicted side-effects in clinical use, here including rashes and the alteration of taste sensation,¹¹ an effect which is attributed to its thiol group. The only solution to this type of problem at present is to prepare a portfolio of compounds related to the particular one which has shown promise, and then test these in turn.

Some indication of the kind of logical progression that occurs in the design of potential inhibitors is set out in the diagrams (Figs.7 and 8). This author's personal choice of compounds is again purely representative.

Fig.8.

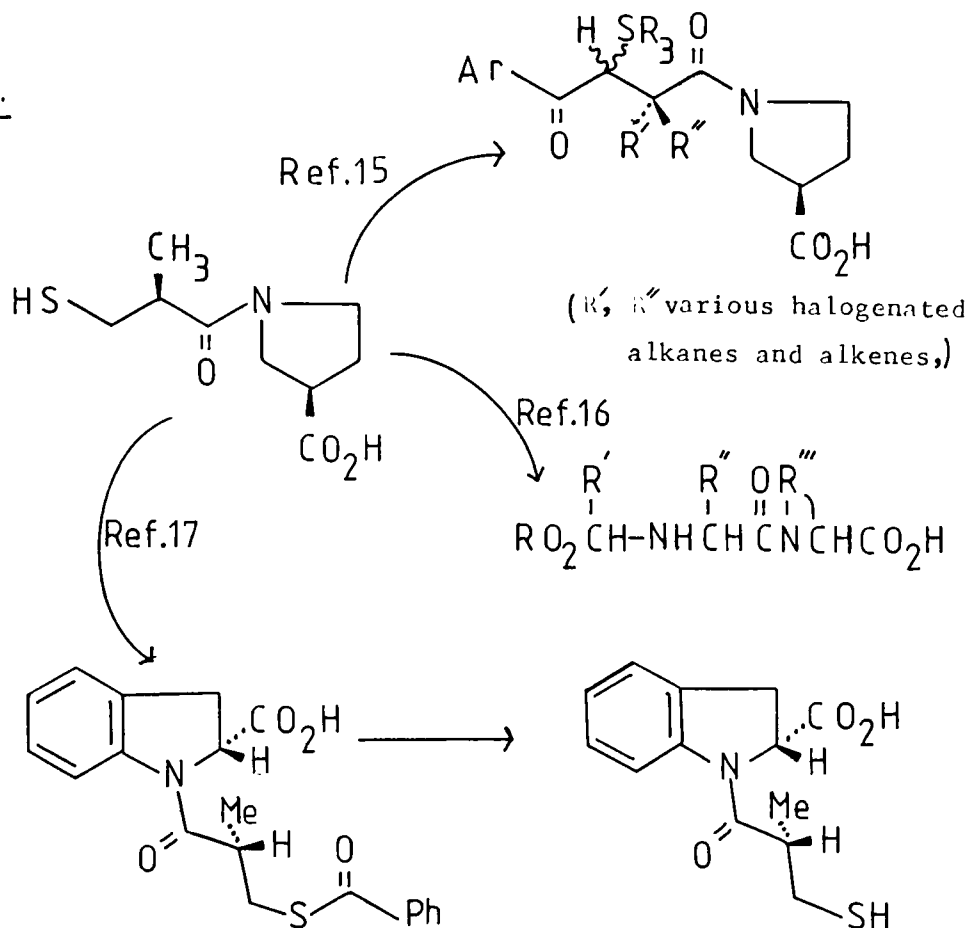

A key feature in the development of these drugs is the initial preparation of compounds containing a penultimate peptide bond, for the purpose of investigating substrate specificity, followed by severe modification or even complete removal of this bond to obtain enhanced bio-stability and antagonistic effects. The ability to prepare small test peptides by the solution-phase methods general to other areas of organic chemistry is thus crucial to the endeavour. Naturally in most cases this is a routine operation; the field of peptide chemistry is comprehensively reviewed and updated¹⁸⁻²¹ and the standard techniques

RESULTS AND DISCUSSION.

CHAPTER 1. Regiospecific introduction of acid-labile protecting groups to the imidazole moiety of histidine.

Protection of the Imidazole function of Histidine.

A large number of interesting peptides and proteins contain histidine; indeed a histidine residue in the vicinity of the active site of several proteolytic enzymes is strongly implicated in their action. Histidine is also known to play a part in both hormone receptor recognition and activity. An increasing number of these peptides are becoming realistic targets for synthesis, generally by means of the solid-phase method. However there has been a tendency amongst chemists to shy away from such targets due to the unique difficulties encountered whilst incorporating this particular residue. An example of such a peptide is Glp-His-Pro (Thyroliberin) whose synthesis has for this reason become something of a standard test in methodology²³.

It has come to be accepted that attempts to follow the normal procedures of peptide synthesis in the presence of an unprotected imidazole function are unwise. For example during activation of the histidine carboxyl group by carbodiimides, intramolecular acylation can take place, resulting in lactam formation²⁴(Fig.1.1).

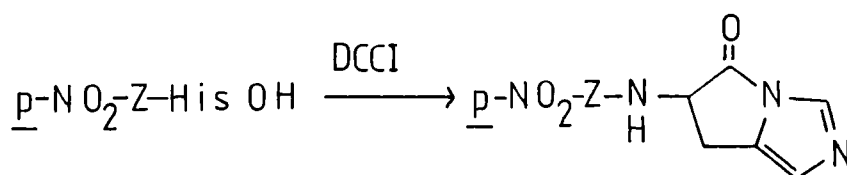
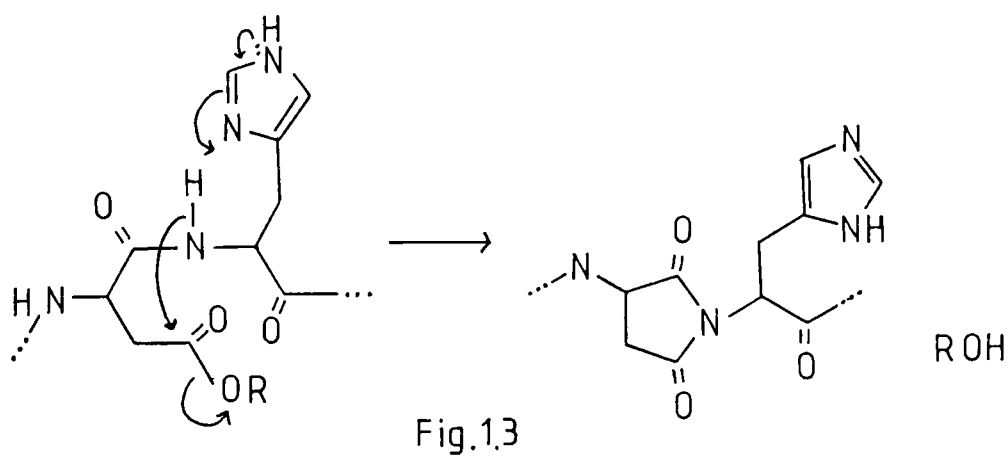
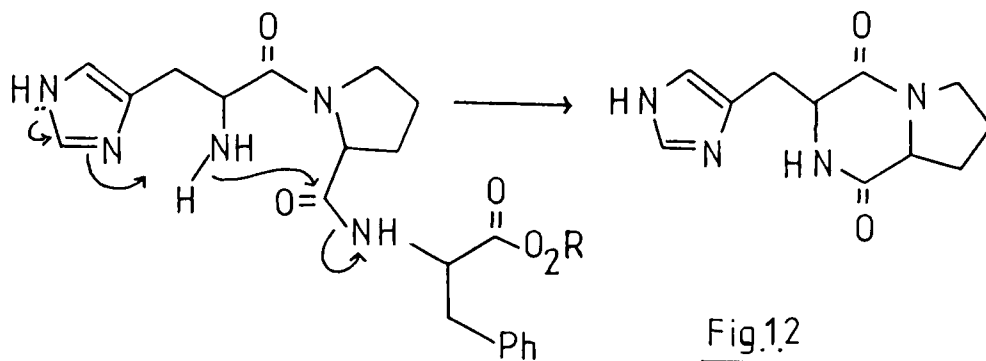

Fig.1.1

It has also been shown that imidazole itself can react with DCCI to give an amidine which is subsequently hydrolysed to dicyclohexylurea; a reaction which in a synthetic context would consume the diimide to no good effect²⁵. In the case of azide couplings too, side reactions have been observed, resulting in the formation of Pauly-negative by-products²⁶. Two examples of more specific side-reactions are i). Intramolecular base catalysed nucleophilic attack, as for example in the case of

histidylprolylphenylalanine esters²⁷(Fig.1.2) and ii). catalysis of the formation of amino-succinyl derivatives from peptides containing aspartic acid. This rearrangement is a well known problem, occurring quite readily with C-terminal glycine; however the situation is markedly worse in the sequence -asp His-²⁸(Fig. 1.3).



In addition to the above mechanistic problems, there are the more practical matters of the preparation, long-term storage and ease of handling of histidine derivatives. Compounds with a free imidazole are prone to N^{∞} to N^{Im} acyl transfer, and being zwitterionic as free acids are notoriously insoluble in the more convenient solvents. This latter consideration can be critical where fully automated solid-phase synthesis is in use.

In our view however the problem which makes the use of side-chain protection imperative is that of racemisation upon activation of the carboxyl group. This can be suppressed by electron-withdrawing and/or appropriately placed imidazole protecting groups. This matter is discussed more fully in chapter two; here it suffices to say that the location of the protecting group is at the heart of the matter and that its location on the imidazole pro(s) (π) nitrogen is desirable.

It must be said however that despite the foregoing arguments, papers continue to appear giving examples of the use of unprotected histidine in synthesis. An example would be the recent synthesis of Galanin²⁹, though here we would take issue with the authors in their claim to negligible racemisation whilst using the azide procedure. That there is a problem in using the azide procedure was realised almost immediately after its introduction. More recently it has been shown that simply neutralization of Boc His N₃·HCl leads to racemisation⁶².

The work described in this chapter can be seen as a continuation of the search for better imidazole protecting groups which has been taken up by a number of workers over many years. In a review of the area³⁰ the authors see perhaps eight classes of protecting groups, to which list we append two or three more (Fig.1.4).

Imidazole Protecting Groups.

<u>Class</u>	<u>Features</u>	<u>Removal</u>	<u>Problems</u>
<u>Benzyl</u> ³¹	Stable to acid and base.	Na/NH ₃ cat. H ₂	Poor electron-withdrawing ability. Slow Hydrogenation.
<u>Trityl</u> ³² (Benzhydryl)	Base stable. Good solubility.	Strong acid.	Bulky, so difficult to introduce to desired location.

<u>Nitrophenyl</u> (Di and Tri)	³³ Acid stable. Good electron withdrawing properties.	Excess thiol.	Unpredictable cleavage by nucleophiles. Incompatible with long syntheses.
<u>Urethane</u>	N^{1m} removed in the presence of N^{∞} Z. Boc stable in short syntheses.	Z; H_2 , cat. Boc; TFA or HCl.	Urethanes generally unstable to nucleophiles.
<u>Piperidino-carbonyl</u>	³⁴ Acid stable. Stable to H_2 .	Hydrazine. Na OH Zn/AcOH	Promising, but insufficient examples of its use.
<u>Tosyl</u>	³⁵ Crystalline, soluble derivatives. Cheap.	V. strong acid	Over-vigorous removal conditions.
<u>Phenacyl</u>	³⁶ Free from racemisation. Orthogonal removal method.	hv or Zn/AcOH	Incompatible with H_2 . Difficulties in removing complexed zinc.
<u>Trifluoroacetylaminomethyl</u>	³⁷ Electron-withdrawing effect enhanced by fluorine.	Dependant upon the acyl group.	Complex and thus expensive. Complications from the introduction of a further chiral centre.
<u>Acetyl</u>	³⁸ Simple regioselective introduction.	N/A	Limited experience of its use as a temporary blocking group.
<u>Trimethylsilyl diphenylphosphonyl</u>	³⁹ Highly specific removal methods.		Known to be useful for N^{∞} -protection, but thought to be too hydrolytically unstable for use here.

Fig.1.4

In response to some of these problems, workers in this group had introduced the π -benzyl-oxymethyl group. This protecting group is stable to basic conditions, to trifluoroacetic acid, and to aqueous solutions of carboxylic acids. It is cleaved cleanly and rapidly by hydrogen bromide in trifluoroacetic acid, or by catalytic hydrogenolysis. Its utility had been demonstrated by the solid-phase synthesis of 5-isoleucine-angiotensin II, Glp His Pro, His Trp and others⁴¹. Latterly it has been used for the preparation of a series of homo-oligohistidines of conformational interest⁴², during the preparation of thirteen angiotensinogen analogues⁴³, and in the synthesis of two closely related Muramyl-dipeptide-luteinizing hormone releasing hormone-lysine adducts of some complexity⁴⁴.

The solution syntheses described in chapter four also make extensive use of this protecting group and serve as further demonstrations of its utility. However this derivative and the π -phenacyl derivative mentioned in figure 4 were designed to fulfil the requirements of a synthetic strategy based upon N^{α} -acid-labile temporary protection. The work described here is concerned with the preparation of compounds having mild-acid-cleavable protection on the side chain, along with base- or hydrogenolytically cleavable N^{α} -protection and is thus entirely complementary.

Preliminary work with the π -t-butoxymethyl group (Fig.1.5) had been promising: it was shown to be unaffected by exposure to nucleophilic and basic reagents in excess for several hours at room temperature, or by catalytic hydrogenolysis at one atmosphere.

Cleavage in 1 occurred cleanly and rapidly with trifluoroacetic acid or with anhydrous HCl or HBr in acetic acid⁴⁵.

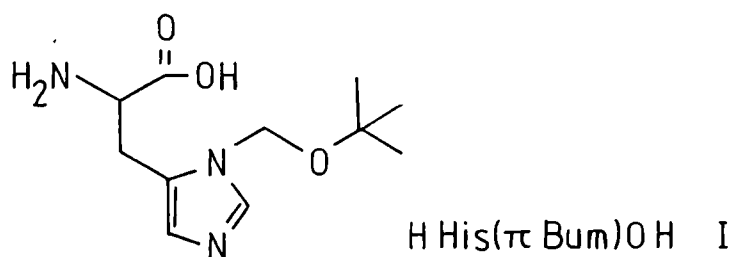
Fig.1.5

The reagent required for the introduction of the group is t-butylchloromethyl ether II which our Milan collaborators⁴⁶ had shown would react smoothly with imidazole to give the corresponding derivative III as a clear distillable oil (Fig. 1.6). We sought an alternative to

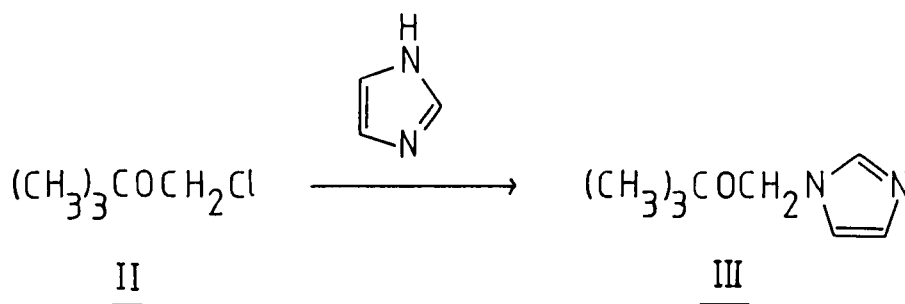
Fig.1.6

the published method of preparation, that is photochemical halogenation of t-butylmethyl ether⁴⁷, as despite modifications the preparation remained unwieldy. Following the timely appearance of a paper by Undheim⁴⁸ we determined to prepare the reagent II by the action of sulphuryl chloride on t-butoxy-methylthiomethyl ether IV, and this reproducibly gave us a sufficiently stable solution for our purposes. Of course the compound is susceptible to slight hydrolysis, and undergoes autodecomposition even in the presence of highly hindered bases (e.g. diisopropylpentylamine), so it was prepared from the stable thioether just prior to use. Our procedure for preparing IV derives from the work of Fojer and Angyal⁴⁹. Dimethyl sulphoxide reacts with acid

The problem associated with acetic anhydride was overcome by treating the resulting mixture with aqueous alkali, anticipating that the acetoxymethylthiomethyl ether V would be completely hydrolysed to sodium acetate, formaldehyde and thiomethanol. To our surprise we isolated methylthiomethanol VI, the simplest of an unfamiliar class of compounds (Fig. 1.9a). Fortunately it was easily separated from the required material by flash chromatography. It proved to be a stable distillable liquid, and a subsequent search of the literature revealed that the structural class has not been entirely overlooked; the next higher homologue having been prepared by the action of formaldehyde on thioethanol in refluxing methanol⁵⁰ (Fig. 1.9b).

Actually thioacetals are normally prepared by the action of sodium salts of alcohols on chloromethyl alkyl sulphides in the presence of sodium iodide as in the case of the benzylic series⁵¹ (Fig. 1.9c). However we were not able to develop satisfactorily the reaction between t-butoxide and methylthiomethyl chloride.

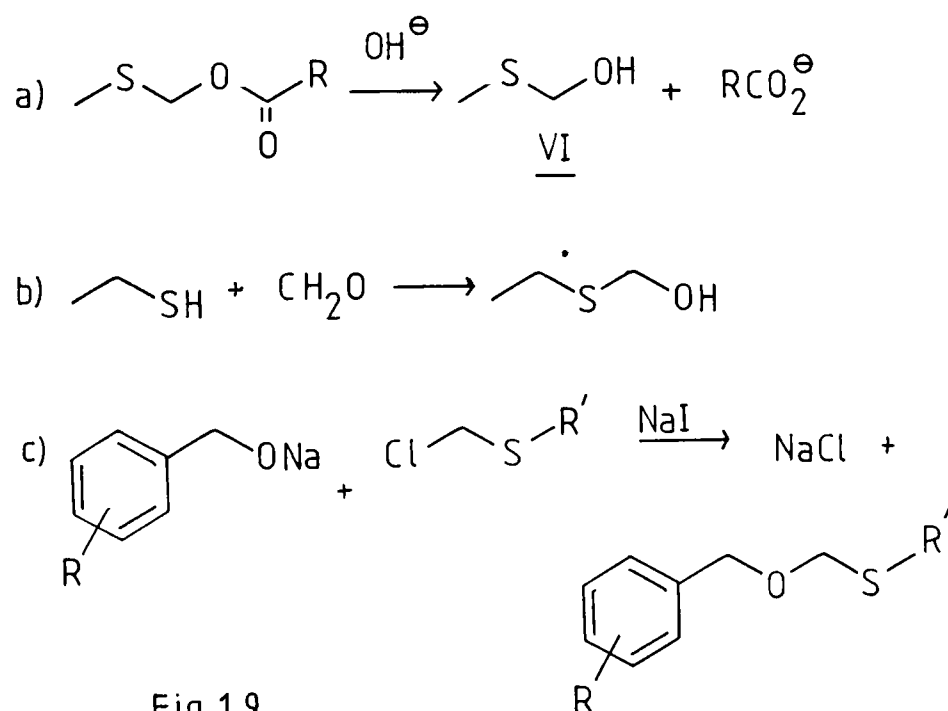
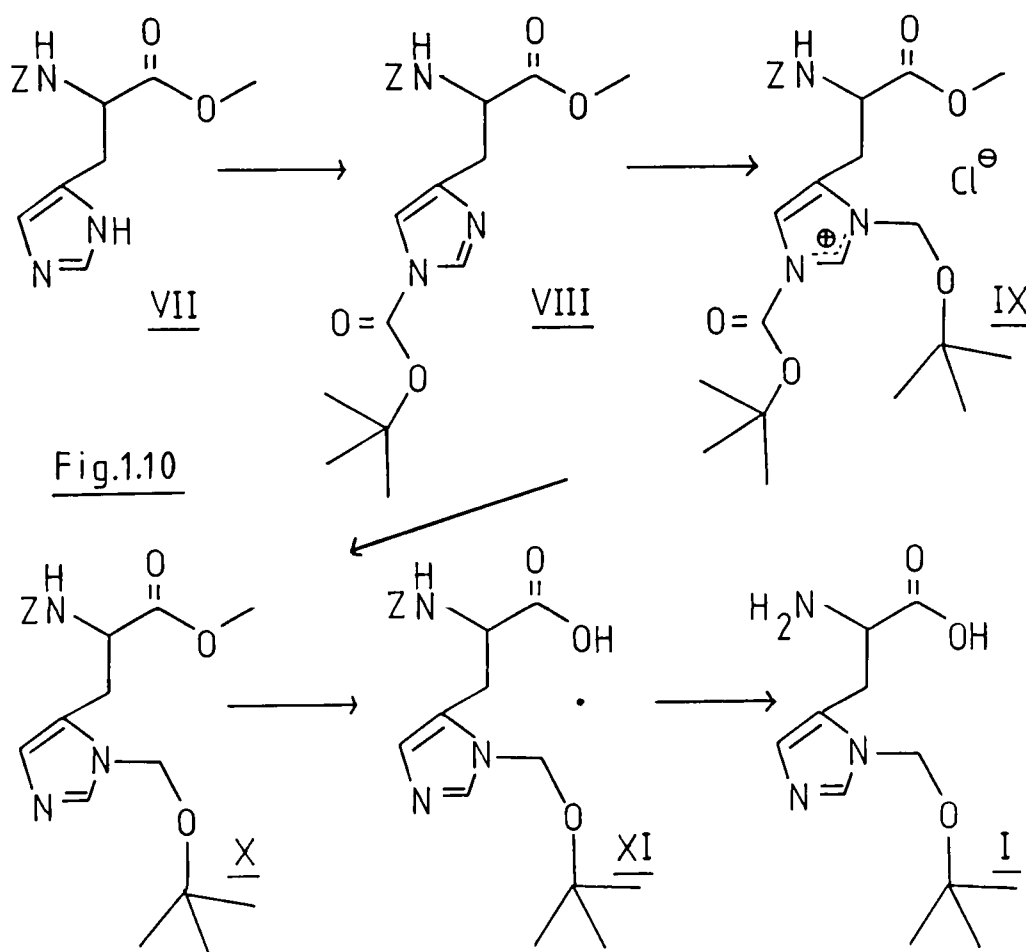

Fig.1.9

With the reagent II now freely available⁵² the way was clear for the preparation of the π -substituted histidine derivative. The overall strategy is simple; preparation of a moderately labile τ -substituted derivative by reaction of a bulky reagent with the free imidazole; separation of any π -substituted contaminant, and subsequent quaternization with the chloromethyl ether. Removal of the τ -substituent then occurs either spontaneously or on gentle provocation. The series of reactions set out in figure 1.10 follows this approach, and some success was achieved by our collaborators⁴⁶ in following it.



Bis-benzyloxycarbonyl histidine benzyl ester (prepared from histidine by three separate steps) was investigated as a possible

intermediate too, but gave poor and somewhat variable yields. This is unfortunate as it offers a short-cut to the free amino-acid through catalytic hydrogenolysis of both remaining benzyl-type protecting groups following π -substitution.

We decided to use triphenylmethyl as our temporary blocking group as its steric bulk ensures 100% π -regioselectivity, and it is of low cost. The overall scheme is shown in figure 1.11.

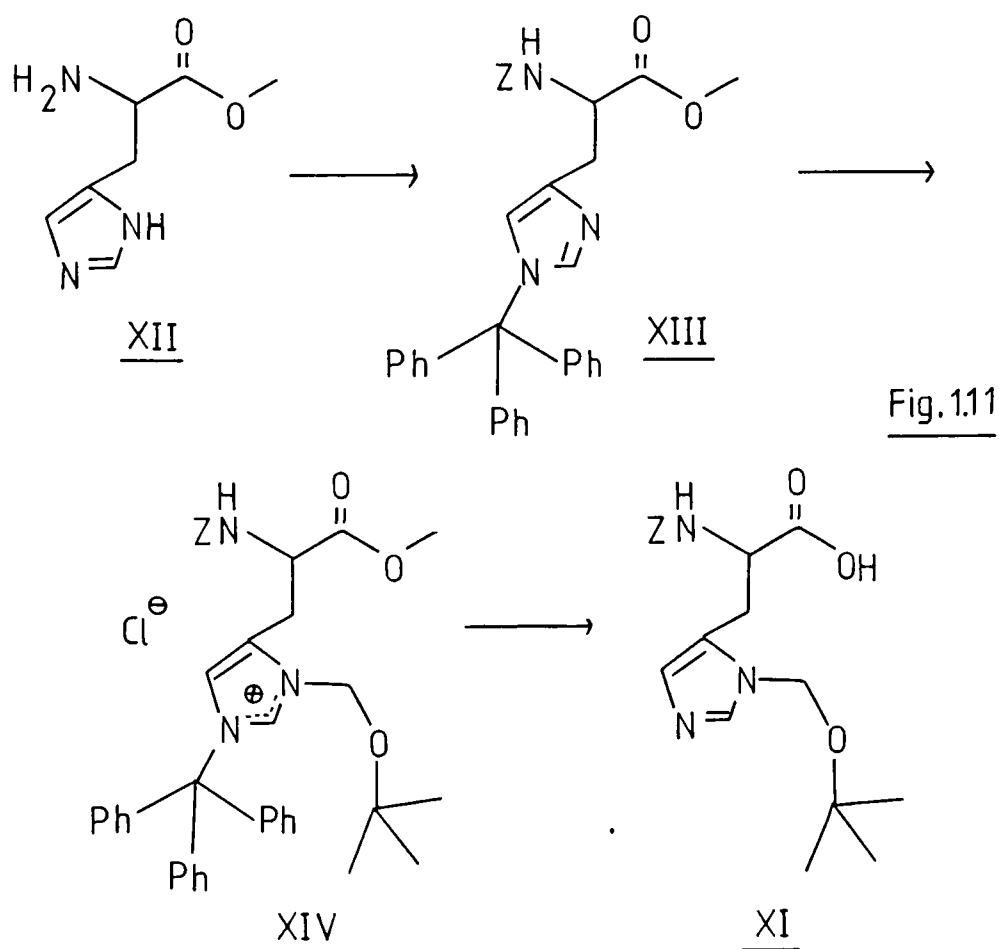

The first two steps were routine and high-yielding; the quaternization step yield was extraordinarily variable, but generally very satisfactory. Concomitant removal of the trityl group and the methyl ester was achieved using moderately strong base to give the desired

product XI. It would be possible to retain the methyl ester by dissolving the imidazolium salt XIV in 80% acetic acid, and one equivalent of silver acetate. In the case of the imidazolium salt IX (Fig. 1.10) loss of the τ -substituent is spontaneous and a separate base hydrolysis of the methyl ester follows. Naturally if the benzyloxycarbonyl group is not required it would be removed by catalytic hydrogenolysis at this stage.

The synthesis was not entirely satisfactory however, not because of the later stages, but because initially it is dependant on a laborious preparation of benzyloxycarbonyl histidine methyl ester VII. Despite careful optimisation of this by Rathbone⁵³ it remains inelegant, proceeding via the bis-benzyloxycarbonyl derivative. Bis-trityl histidine seemed a viable alternative; it is mentioned in the literature though with incomplete characterization, indeed with the briefest possible intimation of its structure⁵⁴. We prepared its methyl ester in reasonable yield in the hope of carrying out the series of reactions set out below (Fig. 1.12).

Unfortunately XV reacted rather poorly with Bum chloride, probably due to a combination of two factors. Firstly the reaction rate itself is slow, as might be expected, and secondly the desired product is more soluble than the hydrochloride of the starting material, which tends to precipitate from the reaction mixture. A trace of the desired material, XVI was observed, but it was not felt worthwhile to pursue this reaction further.

The mesitylmethoxymethyl (Tom) group had previously been considered as a possible acid-labile imidazole protecting group⁵⁶, but access to a corresponding alkylating agent was difficult. Three routes

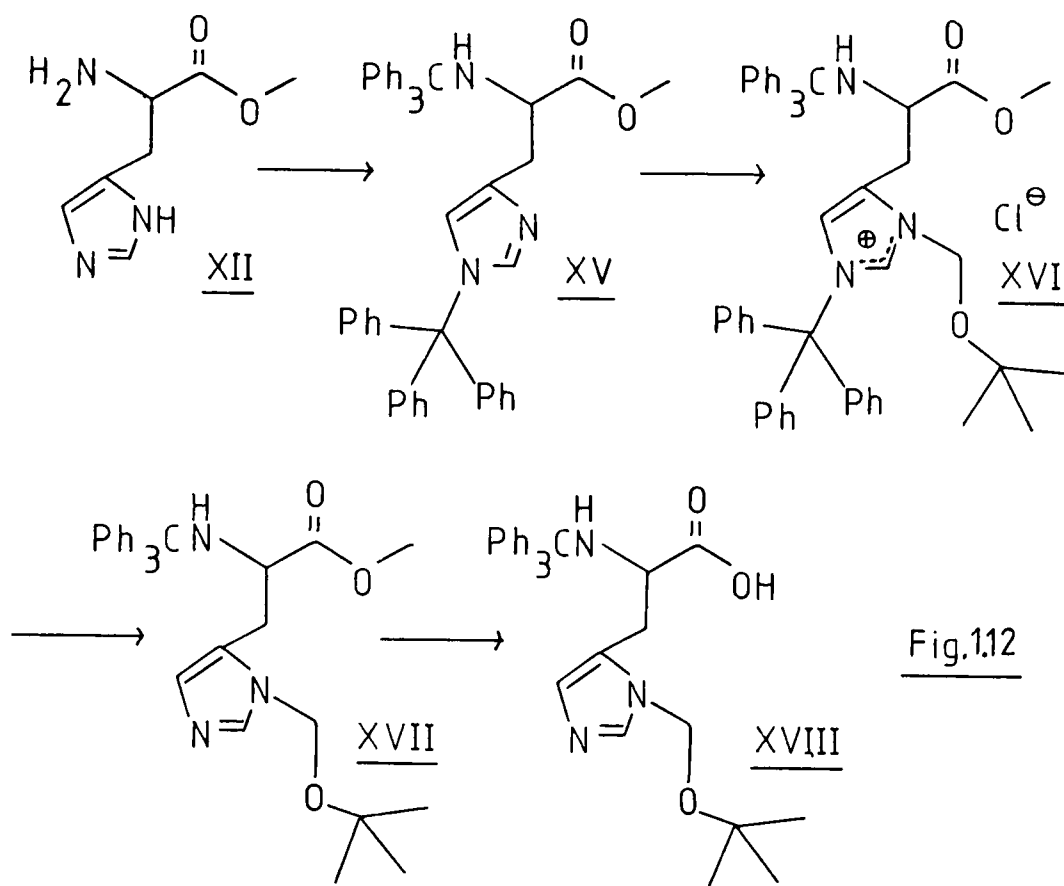

to mesitylmethoxymethyl chloride XIX had been investigated (Fig. 1.13). Direct chloromethylation of XX was initially thought to be satisfactory, but did not turn out to be reproducible⁵⁵. Chlorodecarboxylation of XXI would have been a feasible alternative⁵⁷, and was used to prepare a sample of the alkyl chloride XIX so that its reaction with imidazole could be checked (Fig. 1.14). However the most attractive route is via

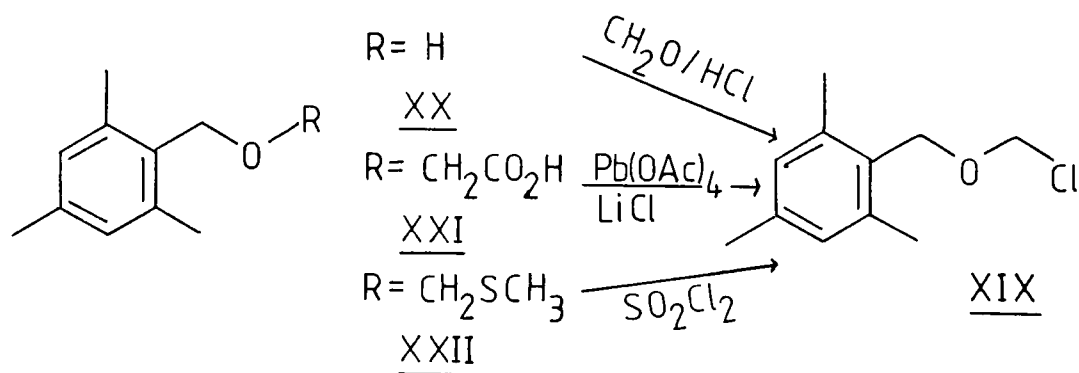

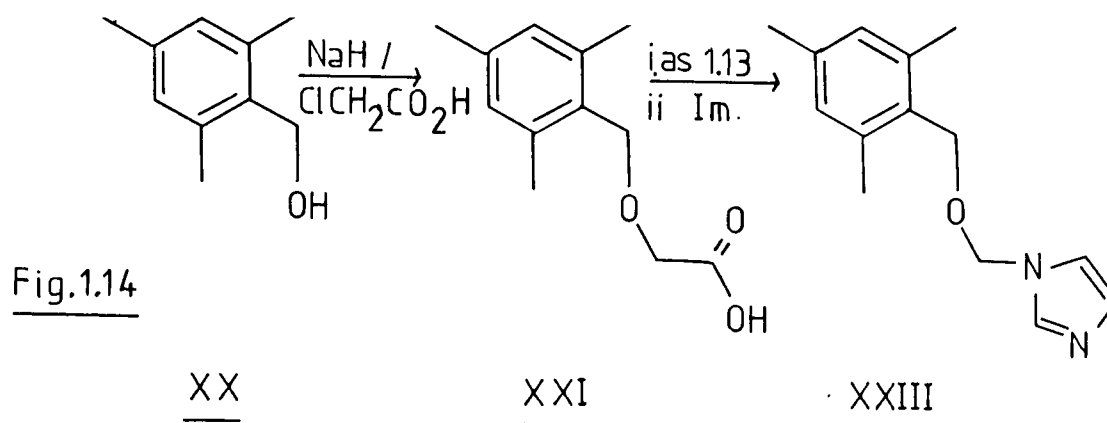

mesitylmethoxythiomethane XXII. This compound had been prepared in this laboratory⁵⁸ by Corey's procedure⁵¹ but the resulting mixture contained only 50% of the required material and needed extensive purification. Using the procedure of Pojer and Angyal⁴⁹ we obtained the thioether XXII and thence the chloromethyl ether XXIX with no difficulty.

The route to a π -Tom substituted histidine parallels that for the π -Bum case, and is set out below (Fig. 1.15).

The preparation of the imidazolium salt XXV was again not completely reliable, but generally satisfactory. Monitoring of the reaction showed the starting material was consumed in all cases. Taking this material through to the free amino-acid by mild acidolytic cleavage of the trityl group, and subsequent hydrogenolysis of the Z-group was a routine operation going in good yield.

The alternative more efficient procedure using the bis-trityl compound XV, abortive in the case of the π -Bum compound, turned out to be more useful in the case of the Tom analogue (Fig. 1.16). The basic conditions used for the breakdown of the imidazolium moiety were not sufficiently strong as to hydrolyse the methyl ester, which could be carried out in a subsequent step if required.

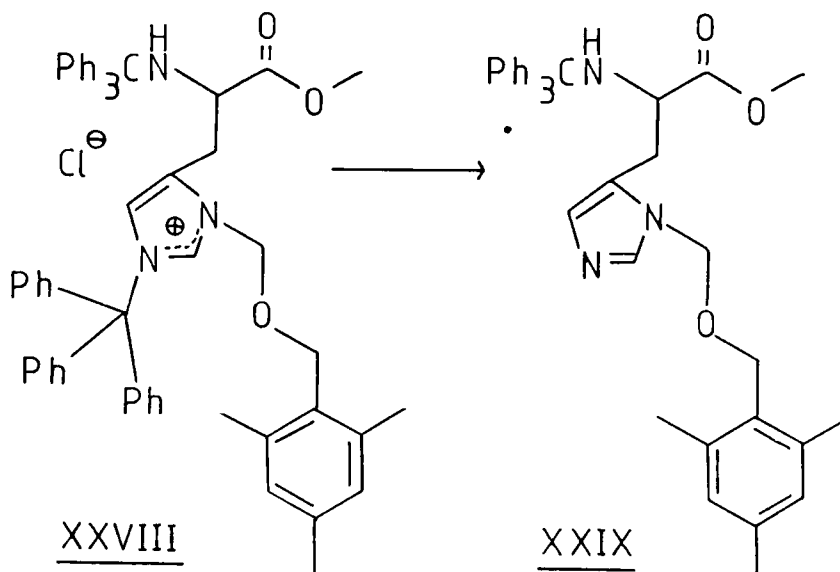
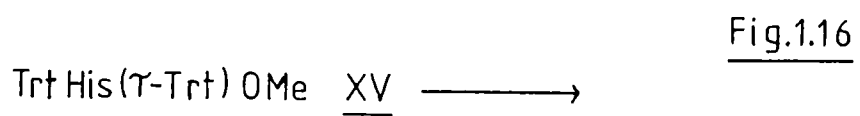
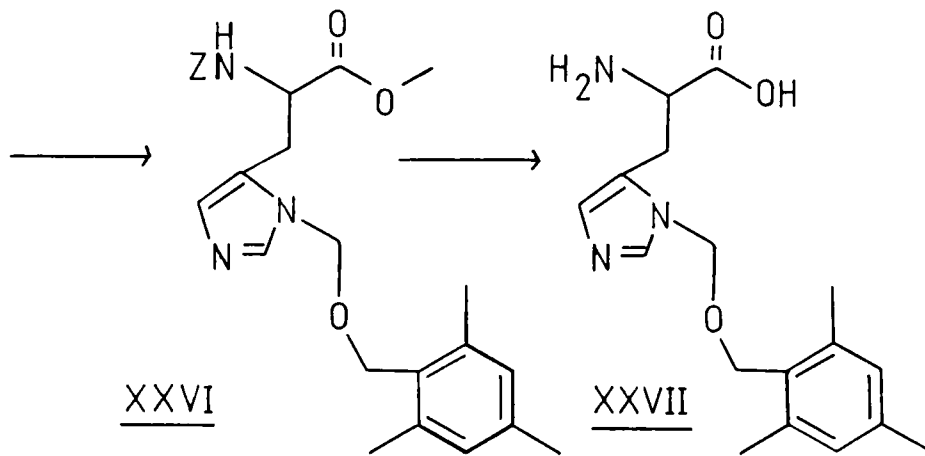
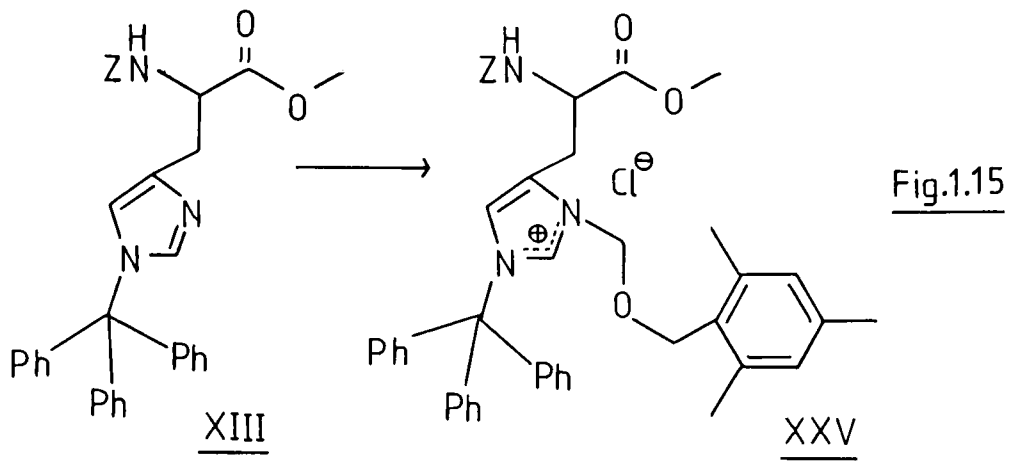

The general approach set out above is not restricted to preparing suitably functionalised amino-acids for peptide synthesis. In the course of our work (c.f. chap. 4) we required a histidine derivative suitably protected such that it had no free protons on nitrogen, and prepared for the racemization-free activation of the carboxyl function. The series of reactions set out in figure 1.17 fulfilled this objective without the need for carboxyl protection.

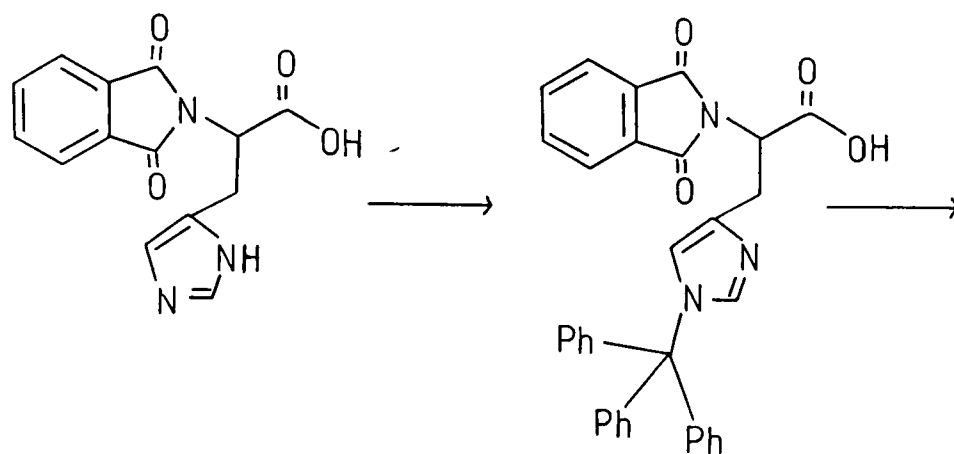
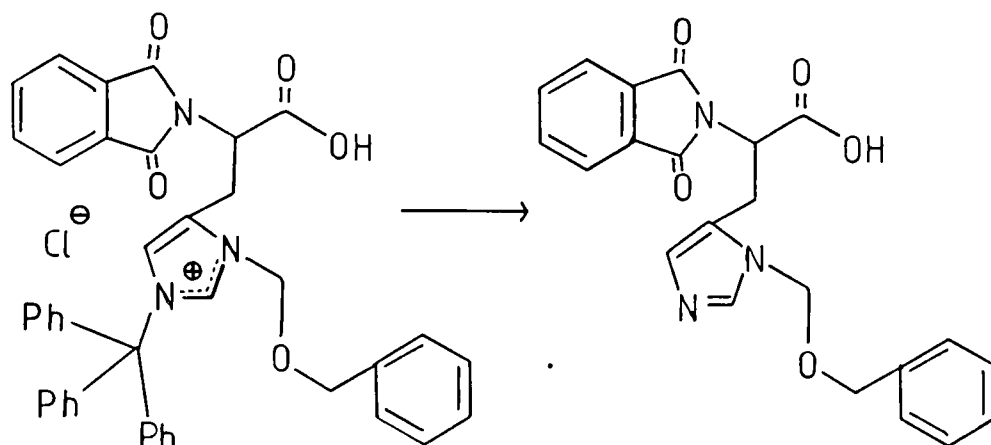
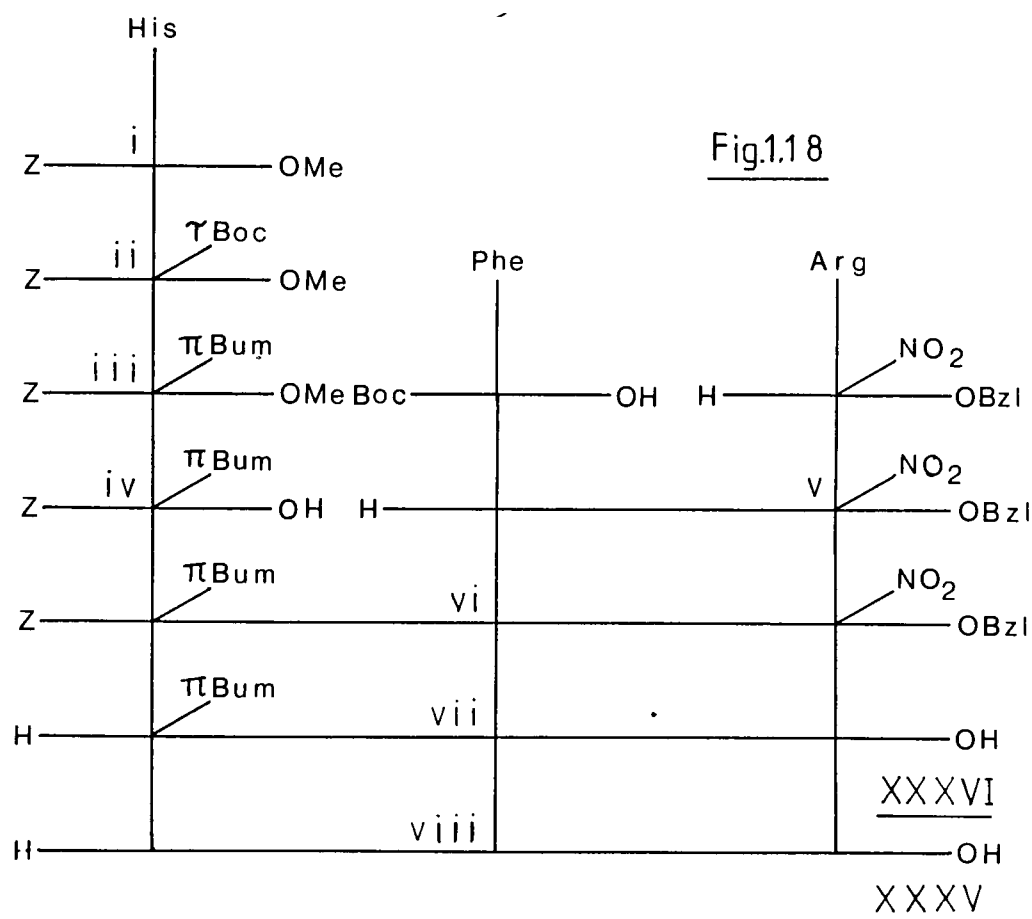

Fig.1.17



The yields, in particular the combined quaternization and de-tritylation step, were disappointing, but this disadvantage is offset by the low cost and simplicity of the reactions. No attempt was made at optimising these yields as the initial experiments furnished sufficient material for our purposes.

It seemed appropriate to prepare a small peptide using a π -Bum protected histidine reagent. We chose to prepare H His Phe Arg OH XXXV as a sample of this material was available prepared via the more established π -Bom route (see chapter four). The synthesis is set out in figure 1.18. It is certainly not the strategy of choice, passing as it does via a penultimate zwitterionic form retaining a lipophilic protecting group XXXVI. (At this stage some material was lost in the manipulations). However the coupling step was quite satisfactory and the final product was identical (counterion differences aside) with the previously authenticated material.



i) a) MeOH/ HCl/ SOCl₂ b) ZCl/ OH[⊖] 64%

ii) BOC₂O 94%

iii) Bum Cl 66%

iv) NaOH (aq), and TFA. 83%

v) DCCI/ HOBT -

vi) " 89%

vii) H₂/ Pd/ C 23%

viii) TFA. 90%

Conclusion.

The review part of this chapter has pointed out the increasingly urgent need for having the imidazole function in histidine suitably protected prior to synthesis. By developing both a practical route to the appropriate alkylating agents and suitable methods of introducing them regioselectively we have made this possible using a class of acidolytically cleavable protecting groups. The two specific members of this class, namely the t-butoxymethyl- and mesitylmethoxymethyl-groups have been satisfactorially introduced into a number of usefully functionalised histidine derivatives.

CHAPTER 2. Differentiation between π and τ derivatised histidines.

In the preceding chapter one strong reason was put forward for requiring histidine protecting groups to be located on the pros-nitrogen, namely retention of chiral integrity during synthesis, and this is discussed more fully below. The preparations described there made use of bulky temporary protecting groups whose required location on the tele-nitrogen was assumed. That work by no means represents the end of the search for histidine protecting groups of different classes, and the need remains for groups whose removal conditions are orthogonal to those prevailing at other stages in a peptide synthesis. However a quite separate matter is the growing demand for histidine derivatives permanently and specifically alkylated on either imidazole nitrogen. This has arisen both in the pharmaceutical field⁵⁹ and in industrial toxicology⁶⁰.

It is implicit in all the above that adequate methods for regioisomeric differentiation are available, whereas this was not in fact the case prior to the work described below. To make matters worse there has been much confusion owing to the currency in biochemical circles of completely contrary conventions for the numerical designation of the heterocyclic nitrogens⁶¹. (We adhere to the nomenclature set out in the Introduction Fig.9).

The Racemisation Problem.

The observation of racemisation in t-butoxycarbonylhistidine azide hydrochloride, together with the demonstration of the reversible formation of a cyclic imidazolide from this compound led Veber⁶² to propose this intermediate as the optically labile moiety. He suggested that a pros-substituted imidazole does not prevent cyclisation and therefore racemisation. However it has subsequently been shown⁶³ (for N^α -benzyloxycarbonyl- N^γ -phenacyl histidine activated by the diimide method) that loss of optical activity proceeds via racemisation of the O-acyl urea present in low concentration (Fig.2.1). Furthermore the

strength and the shift in equilibrium from B to A. Unfortunately no pros-substituted compounds were examined, (at least these authors assumed all their protecting groups were located on the tele-position).

The susceptibility to racemisation which activated histidines not bearing a suitable protecting group on the pros-nitrogen show upon each fresh study only reinforces our view that such protection is mandatory during peptide synthesis.

Histidine Regiochemistry.

It has been common practice to assume that in the reaction of histidine side-chains with equimolar amounts of electrophilic reagents the main product will be that arising from attack at the least hindered, ie tele, position⁶⁵. In our experience this is a valid assumption. Acylating agents, 2,4-dinitrophenyl fluoride, toluene-p-sulphonyl chloride and very hindered alkylating agents generally give a much greater predominance of one product having the tele-orientation. Alkylating agents which do not have overwhelming steric demands, however, give mixtures which may contain up to 30-40% of the pros-substituted isomer. If an excess of alkylating agent is employed, under some circumstances the mixture of monoalkyl isomer and disubstituted product can contain comparable amounts of each of the former. In the case of the unhindered highly reactive methylating agent methyl methanesulphonate, it has been reported that the second-order rate-constant for first reaction at the pros-nitrogen of N^α-acetylhistidine methylamide is significantly greater than that for first reaction at the tele-nitrogen, and the generalisation that tele-substituted products are invariably in predominance has been contradicted⁶⁶.

More recently⁶⁰ the reaction of methyloxirane with N^α-benzoylhistidine was shown to give a 2:1 mixture of alkylated products (presumably

$\gamma:\pi$), which required separation by chromatography. The di-substituted imidazolium salt was also formed as a by-product, but slowly; the quantity increased steadily and irreversibly with prolonged reaction. Similarly,⁶⁵ N^α -benzoylhistidine methyl ester was reacted with bromoacetone to give a pair of 2-oxopropyl derivatives in approximately the same ratio.

The danger of confusion is heightened when an experiment gives only one of a possible pair of regioisomers in poor yield. A case in point would be Li's⁶⁷ preparation of N^α -Boc His(Im-Boc) OH where the only characterised material was obtained in 23% yield, so that the grounds for assuming the regiochemistry are particularly weak in this case.

Differentiation between derivatised histidines.

There are two existing methods of distinguishing between the regioisomers; firstly the method of chemical degradation which has proved useful in a few cases. For example with Z His(Im-Dnp)OMe a novel application of the well established Bamberger-type^{68,69} ring-opening with benzyl chloroformate and alkali gave a compound whose structure could be unambiguously assigned through its n.m.r. spectrum. However the method lacks generality. Secondly a more useful but completely empirical method involves measurement of the cross-ring coupling constant between protons 2 and 4. It has been proposed⁷⁰ that a value between 1.1 and 1.4 Hz indicates tele-substitution, whereas a value between 0.9 and 1.0 Hz indicates pros-substitution. This seems a slender distinction, and although we have yet to encounter an example which disobeys the rule, in the course of this work we came across a value which falls well outside the hitherto accepted range (FmocHis(γ -Ppc)OH. CXXIV, $J = 1.7$ Hz). It is frequently difficult, and in complex structures impossible, to measure these coupling constants.

Our new and more general differentiation method involves quaternisation of the 1m-substituted derivative using any convenient methylating agent (generally MeI suffices), followed by removal of all of the protecting groups originally present. By this method the unknown compound will be converted into one or other of the pair of compounds H His(π Me)OH, XXXVIII and H His(τ Me)OH XXXIX. (Fig. 2.3). Under appropriate conditions (detailed in Chapter 6) it proved possible to separate a mixed sample of these two amino-acids using the short column of a commercial amino-acid analyser. The emergent peaks were quite separate and easily integrated. This was most fortuitous, as this particular analytical technique has great sensitivity, (it is possible to detect a few tens of n Moles of material without difficulty), and requires no pre-purification of the sample. In addition the standard acid hydrolysis conditions used in preparing a peptide for analysis,

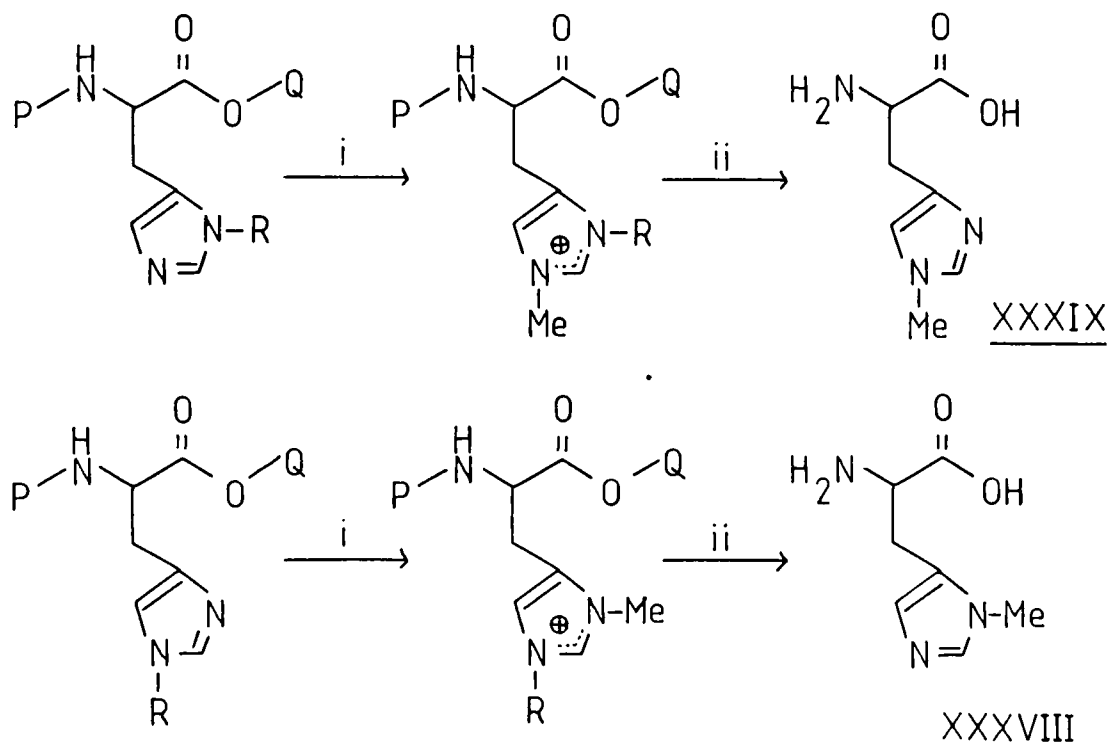

i) MeI / solvent.

ii) 6M HCl.

Fig.2.3

when used here, will remove virtually all of the protecting groups in common use. In the few cases where this might not be relied upon an additional step can be interposed where removal conditions specific for the substituent in question are applied. For example in the case of the pair of compounds bearing methoxyethoxymethyl- (Mem-), groups following methylation the residue was treated with anhydrous zinc bromide.

(Fig. 2.4).

It is only in the case of simple alkyl substituents, where there can be no appropriate method of decomposing the imidazolium intermediate, that the method reaches its limitations.

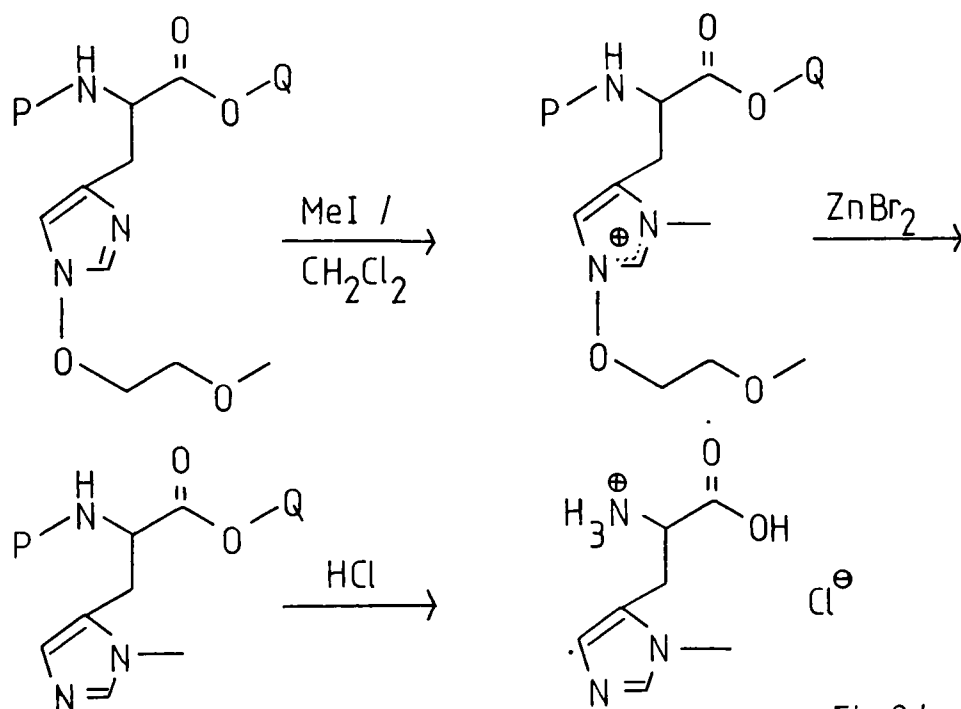

Fig.2.4

It was helpful that the pair of 1m-methyl histidines are commercially available, but they too were ambiguously labelled "1-methyl histidine" and "3-methyl histidine". So although it was possible to take all of the twenty or so compounds available to us and assign them to either series of compound we had not established an

absolute reference point. This was provided by the structure of Boc His(π Bom)OH. XL, which had previously been elucidated by X-ray⁷¹ crystallography. In fact the actual material used for the crystallographic work was used in our experiments. By the above method XL was related to "3-methyl histidine", which is thus the tele-isomer XXXIX. It follows that "1-methyl histidine" is the pros-isomer XXXVIII.

It is conceivable that due to contamination by a minor isomer, or by premature loss of a protecting group, that methylation could selectively pick up the wrong isomer. To cross-check we always compared the total quantity of methylated material against the residual histidine (if any) to establish that substantial reaction had occurred. In no case did any ambiguity arise. The peaks on the amino-acid analysis output corresponding to histidine and ammonia were close to but not obstructive of the two other peaks (Fig. 2.5).

The full list of histidine⁷² compounds examined is given in Figure 2.6. The compound XIII, the basis of two reaction sequences described in Chap. 1, and the intermediate used for example in the literature preparation of Z His(π Phen)OMe LI³⁶ thus becomes a subsidiary reference point. In the case of XLVII no methylated histidines were observed upon amino-acid analysis. To obtain a result here it would have been necessary to interpose an hydrogenolysis step, but in view of the further results described below on this and six other Im-benzyl compounds, this was not attempted. The tosylate XLVIII was notably resistant to methylation, indicative of the powerful electron withdrawing effect of the tosyl-function, and required the use of $\text{Me}_3\text{C}^{\oplus} \text{BF}_4^{\ominus}$ in dichloromethane over several hours.

The structural assignments made using the above method were in all cases in agreement with those which had been assumed from their particular methods of synthesis.

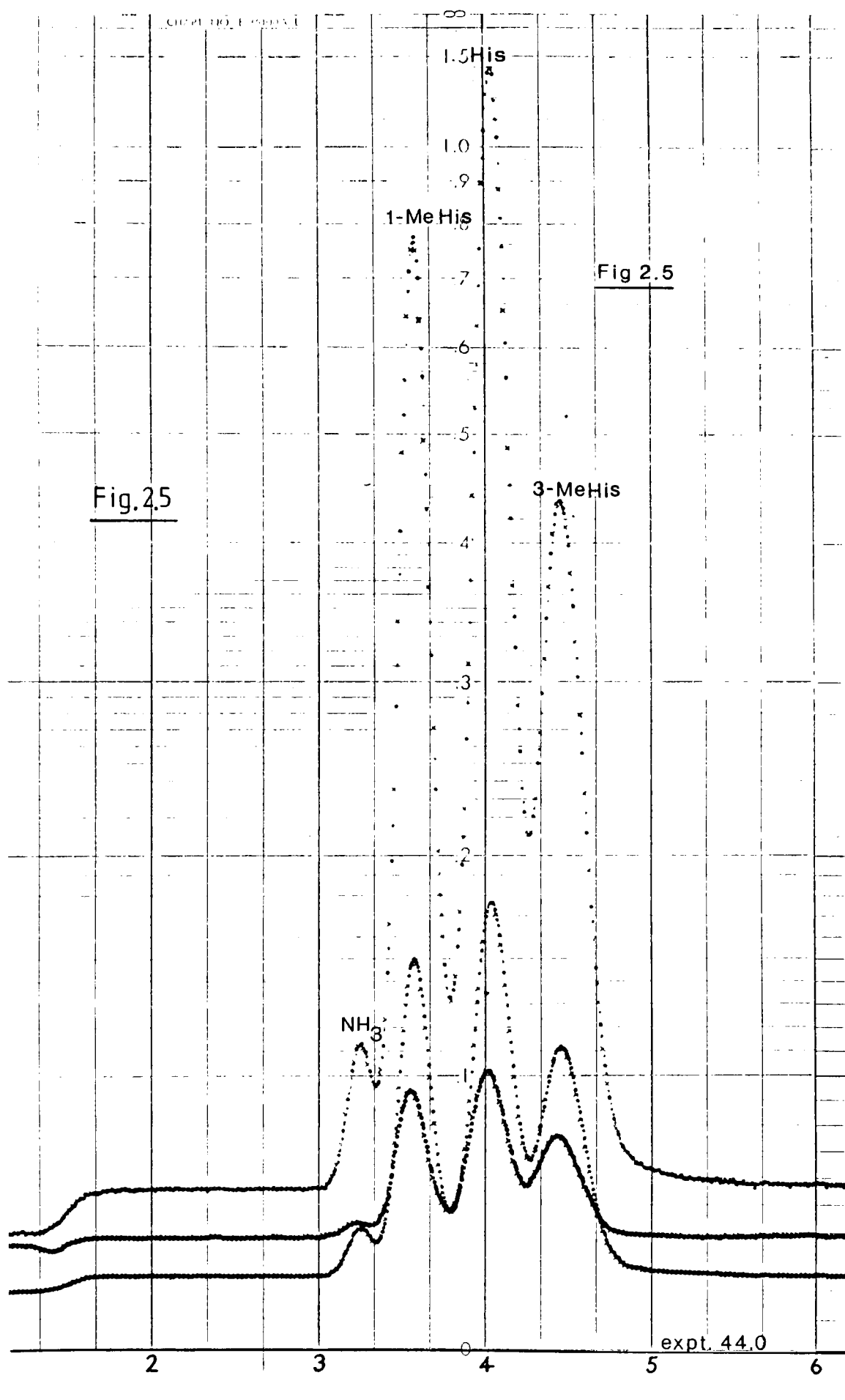

Compound	Source	Ref. No	Comments
Boc His(π Bom)OH	P	<u>XL</u>	Absolute reference
Boc His(π Bom)OMe	P	<u>XLI</u>	
H His(π Me)OH	C	<u>XXXVIII</u>	} Subsidiary references
H His(τ Me)OH	C	<u>XXXIX</u>	
Z His(τ Trt)OMe	P	<u>XIII</u>	General intermediate
Z His(π Bum)OMe	I/P	<u>X</u>	
Z His(π Bum)OH	I/P	<u>XI</u>	See chap.1
Z His(τ Bum)OMe	I	<u>XLII</u>	
Z His(π Mem)OMe	I	<u>XLIII</u>	} Pairs of novel
Z His(τ Mem)OMe	I	<u>XLIV</u>	
Z His(π Sem)OMe	I	<u>XLV</u>	} protecting groups } under investigation
Z His(τ Sem)OMe	I	<u>XLVI</u>	
Z His(π Bzl)OH	P	<u>XLVII</u>	
Z His(τ Tos)OMe	P	<u>XLVIII</u>	
Z His(τ Fpc)OMe	P _{Ib}	<u>XLIX</u>	
Fmoc His(τ Fpc)OH	I _c	<u>XXXVII</u>	
Fmoc His(τ Boc)OH	I	<u>L</u>	

Fig.2.6

C = commercially available I = prepared by our collaborators and
purified in this laboratory. Ib = prepared by Dr Walker. ¹⁴²
Ic = Kind gift of Dr J.D. Richards. ¹³⁰ P = prepared in this laboratory.

The method set out, though sound in its argument, passes through a kind of "logical bottleneck" in relating all the compounds to XL. More importantly it is a primary method not suitable for a "once-off" examination of a single compound. For these two reasons we sought a further criterion, using n.m.r.

We reasoned that on whichever of the two imidazole nitrogens a substituent was located that upon irradiation a nuclear Overhauser enhancement should be observed from it to the proton on Im-2. (Providing of course it has any protons in the vicinity of the point of attachment). However there should only be an n.O.e between the substituent and the other ring proton if it is located on the tele-nitrogen. This should follow from the rapid falling off of n.O.e effects with distance. In practice it is normally easier to irradiate the imidazole protons themselves as they are generally well downfield and easily identified, and look for enhancements elsewhere in the spectrum. The pair of methylated histidines made an obvious first target for investigation, and they clearly supported the thesis (Fig.2.7).

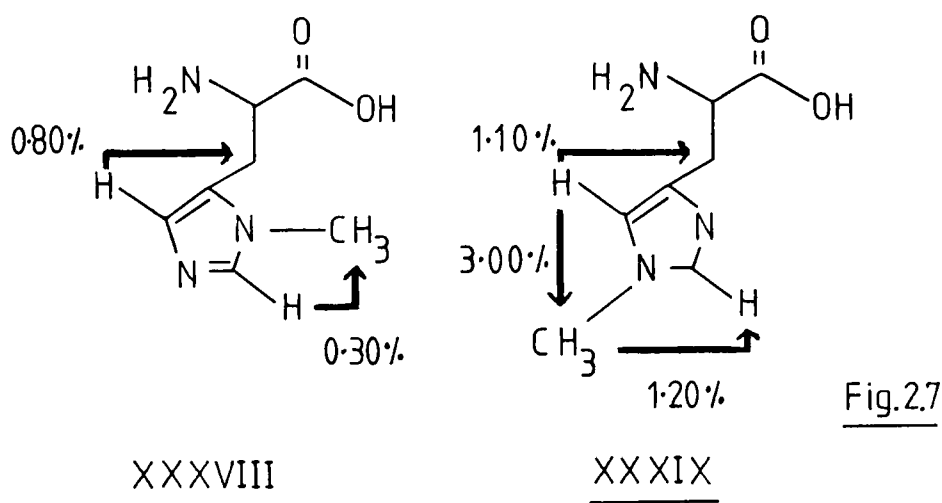

Turning to our principle reference material XL we saw the expected enhancement from the proton on Im2 to the 3om-methylene between the hetero-atoms, and interestingly a further effect on the benzylic methylene. This suggested the molecule might exist in solution with the two aromatic rings overlying one another. With this in mind we also examined the methyl ester XLI and noted an enhancement of the signal from the benzylic methylene on irradiation of Im4 which supports the

suggestion (Fig.2.8). The molecule clearly has several minimum energy states available to it; in the course of the crystal structure determination referred to above, two further completely different conformations were found in the single unit cell. These have been subsequently shown to be at similar energy minima⁷³.

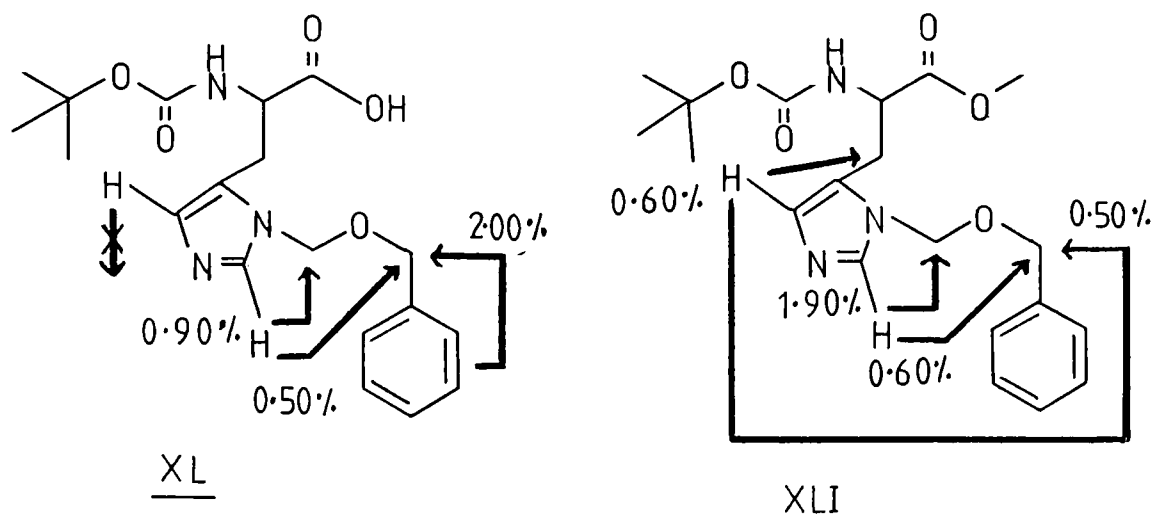
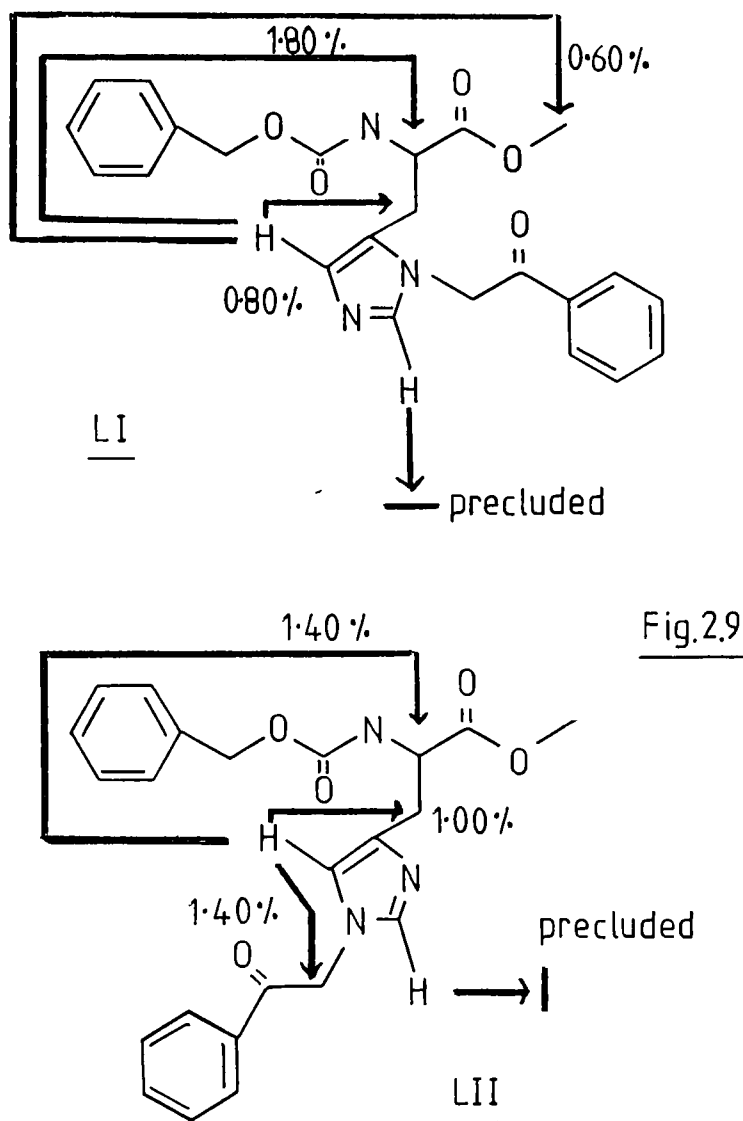

Fig.2.8

We next returned to a pair of derivatives prepared in the course of much earlier work on histidine protection³⁶, the phenacyl derivatives. The samples needed a little work to re-purify them and obtain them in an equivalent chemical state, free from their hydrobromide salts. Compound LI (3 His(π Phen)OMe) had been prepared via the tele-trityl derivative, so conceivably the loss of trityl cation could precede reaction with phenacyl bromide. Worse, the corresponding tele-phenacyl compound LII had been isolated from the mixture arising from reaction of a structurally undefined Im-silver salt with phenacyl bromide. Although unfortunately we were prevented from irradiating Im2 by the proximity of its chemical shift to other aromatic protons, irradiation of Im4 gave an

unambiguous result confirming the assumed structures to be correct (Fig. 2.9).



A recent paper has appeared in which a range of novel regiospecifically alkylated histidine derivatives have been prepared using the phenacyl function as a temporary blocking group⁵⁹; in fact proceeding via LII in some of the examples given (Fig.2.10).

(Our spectroscopic data is in complete agreement with these authors' compound N^o 20, which they confusingly name as a 1-(2-oxo-2-phenylethyl)-derivative). As the preparations described therein made use of an

intermediate $N^{\pi}-N^{\infty}$ cyclic urea LIII, establishing the structure of LII with certainty validates the use of this intermediate here and in its more general applications.

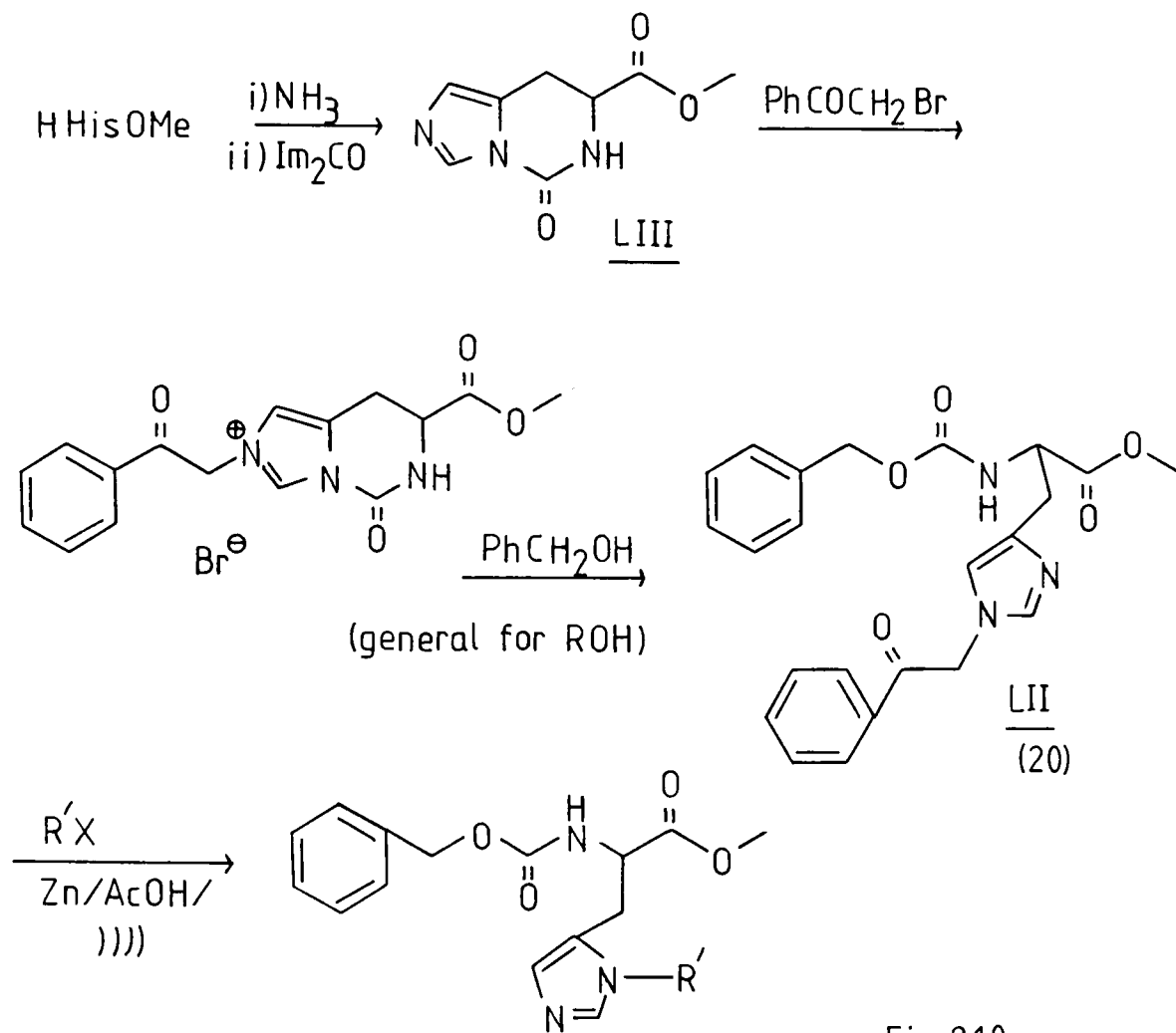

Fig.2.10

Examination of the t-butoxymethyl derivative X prepared as described in Chap.1 (and the free acid derived therefrom X1) together with the matching compound His(τ Bum)OMe prepared for the purpose by direct reaction of Z His OMe with Bum-Cl, also gave a satisfactory result (Fig. 2.11).

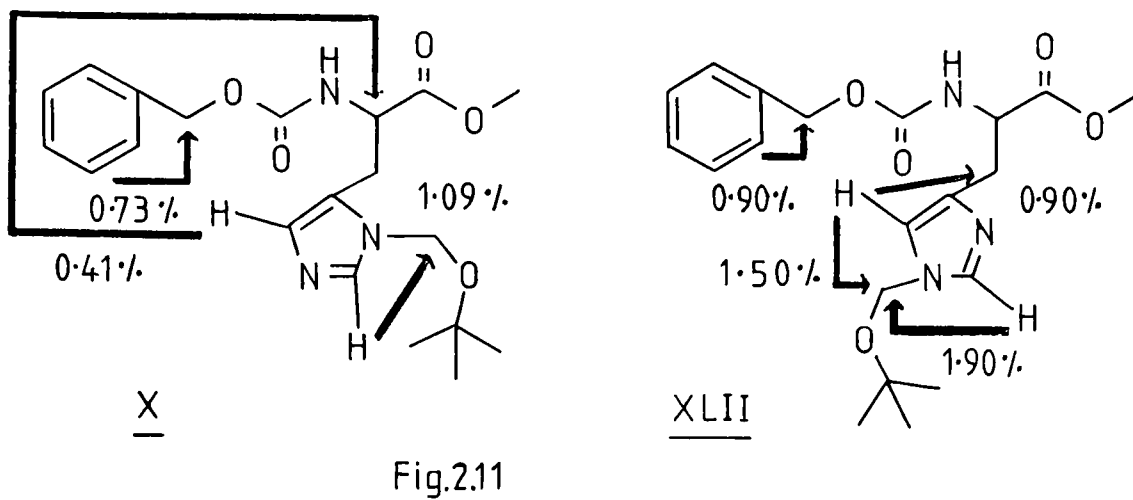

Fig.2.11

We then turned to a number of histidine derivatives bearing protecting groups still under investigation in this laboratory:

The β -methoxyethoxymethyl (Mem) group was introduced by Corey⁷⁴ as an alcohol protecting group complementary to others in general use. It proved stable under most conditions, in particular strong base, and the removal conditions; $ZnBr_2$ or $TiCl_4$ left acetate, benzyl ether, THP, trichloroethyl ether etc untouched. Its use as an imidazole protecting group seems attractive as the majority of protecting groups in general use in peptide chemistry are also stable to mild Lewis acid.

The β -trimethylsilylethoxymethyl (Sem) group is the simplest example of a class of β -eliminating groups susceptible to fluoridolysis. These derive from Carpino's successful introduction of the β -trimethylsilylethoxycarbonyl (Teoc) group⁷⁵, which collapses to a series of volatile by-products following attack by tetraethylammonium fluoride. The Sem group is particularly attractive as the development of mild fluoridolysis as a final, orthogonal step during peptide synthesis is taking place elsewhere^{76,77} at the present time.

The two tele-derivatives XLIV and XLVI were obtained by direct reaction of 2 HisO11e with Hcm and Sem chloride respectively. The corresponding pros-substituted compounds XLIII and XLV were prepared via VIII. The n.O.e experiments (Fig.2.12) yielded a superabundance of effects, particularly in the case of the pros-derivatives. Some of the key enhancements are particularly large and clear, e.g. in compound XLV

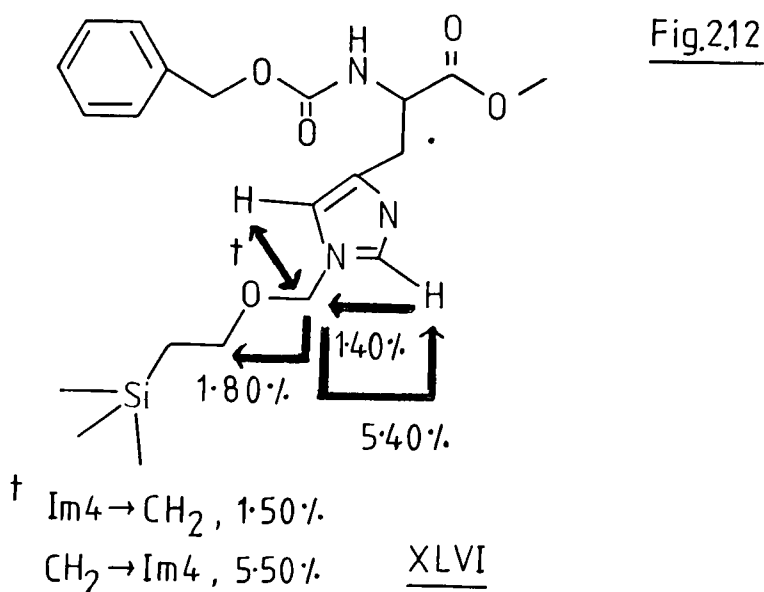
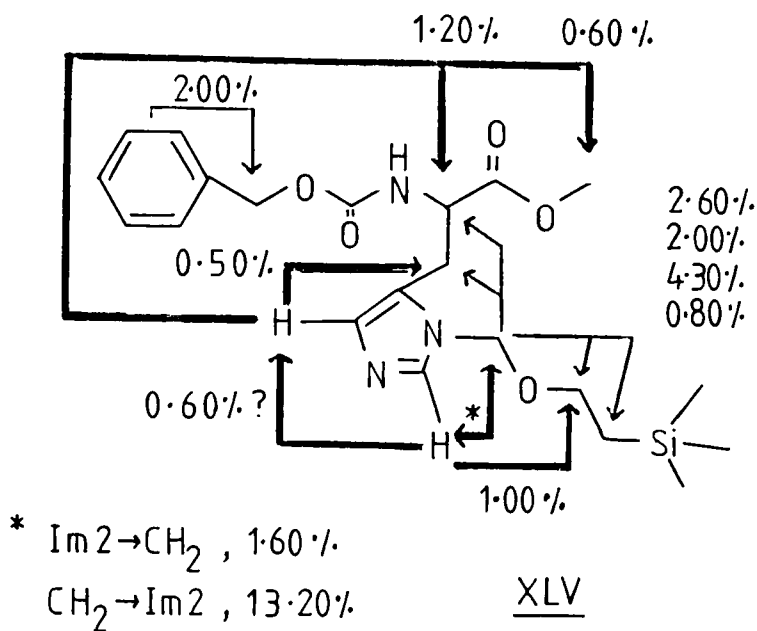

Z His(π Mem)OMe XLIII

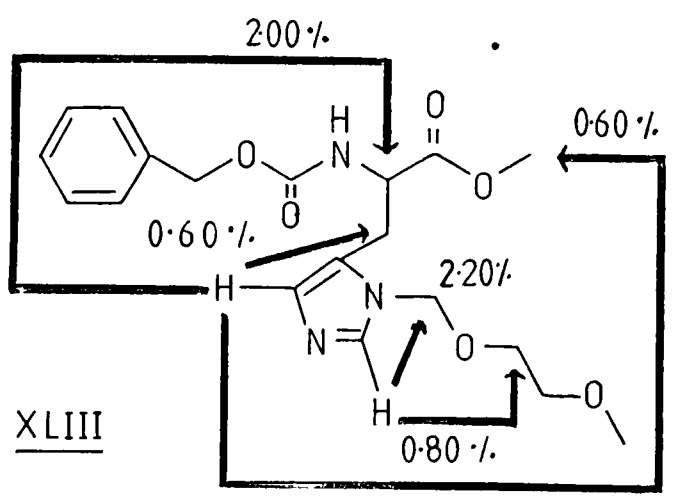
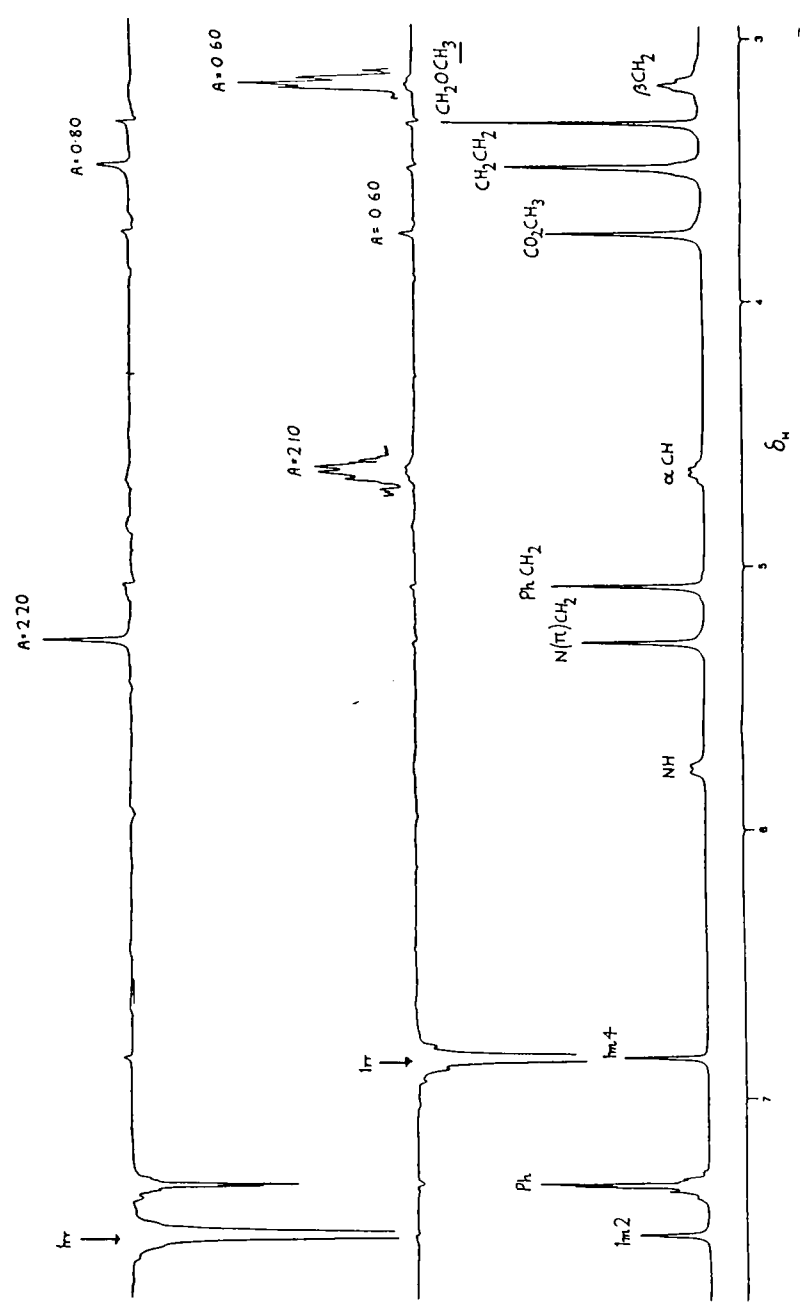

Fig.2.13a

ZHis(τ Mem)OMe XLIV

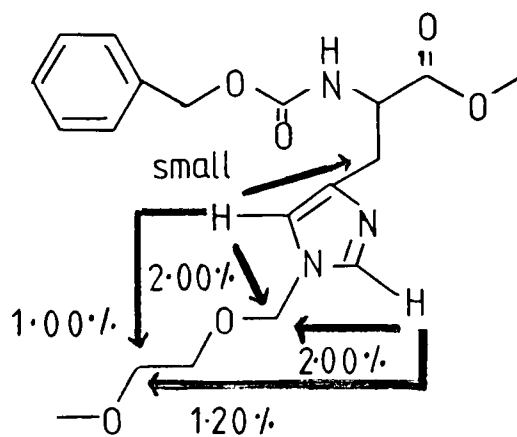
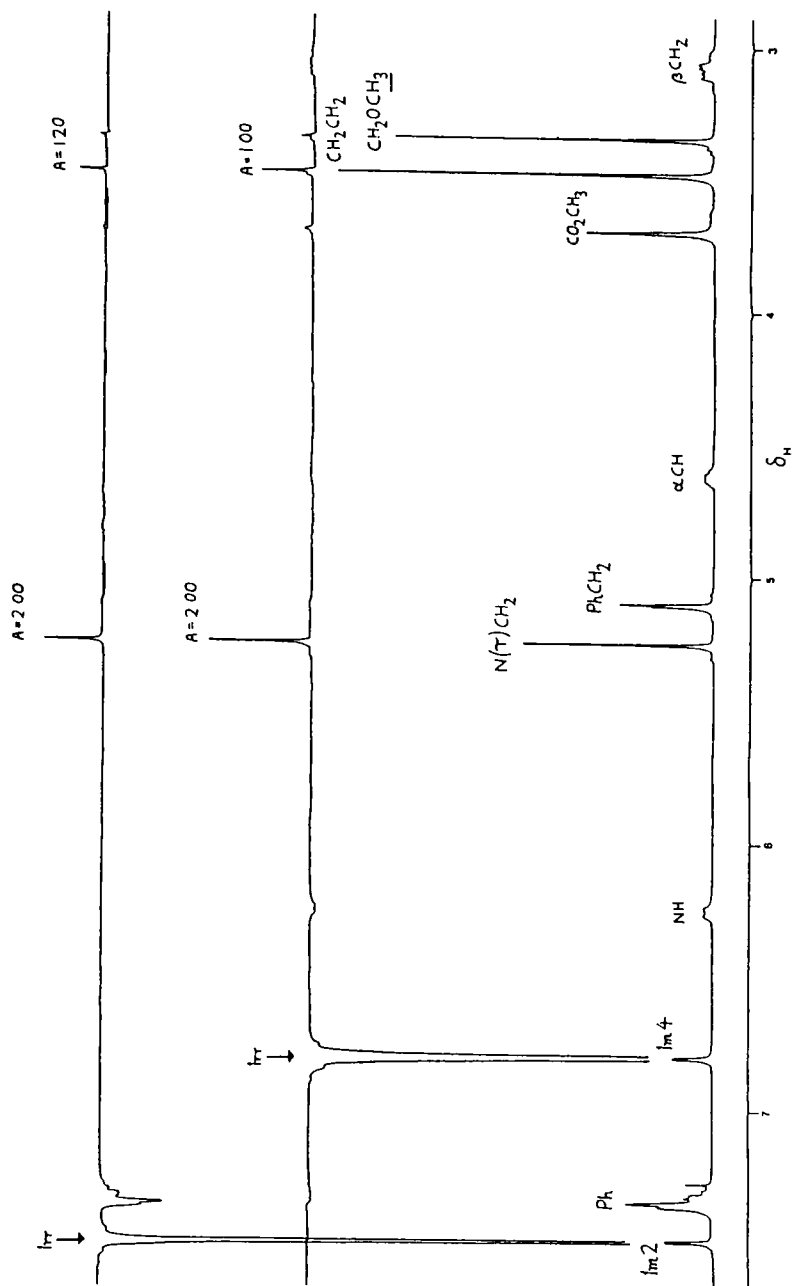
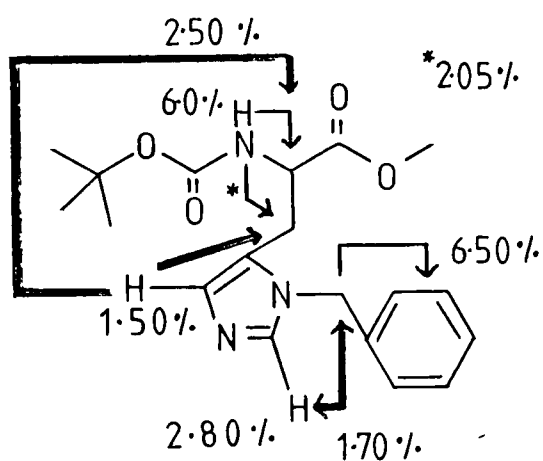
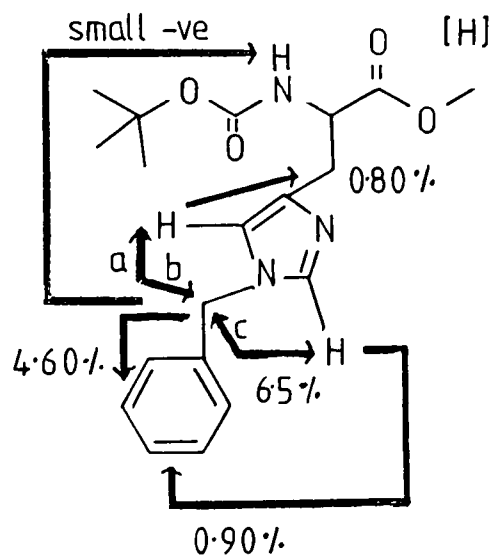

Fig.2.13b

XLIV

a 13.2% enhancement is observed between Im2 and the methylene on nitrogen, and none between Im4 and that same methylene. The spectra for the pair of Mem derivatives present a visually clear picture, and are given in Figures 2.13a and b. Nuclear Overhauser enhancements are shown (in the form " Δ =") as percentage difference spectra. Confirmation of the structures of XLIII and XLV clears the way forward to their further examination as viable protecting groups.

The preparation of pharmaceutical targets was again recently cited as the reason for preparing a series of modified histidine derivatives⁷⁸. The author expounded a method of preparing compounds having groups of the benzylic class regioselectively placed on the imidazole ring; reacting aryl triflates and mesylates with Boc His(τ Boc)OMe LIV. The simplest derivative mentioned therein was available to us, that is Boc His(π Bzl)OMe LV, and our spectroscopic data is in complete agreement with his. It so happens the corresponding tele-benzyl isomer is commercially available too, as its free acid LVI (ambiguously named), and thus also is the methyl ester LVII available for comparison. We were anxious to examine these materials as they are not susceptible to the methylation/degradation analysis without introducing further complications (hydrogenolysis etc), and we were gratified to find the expected structures to be clearly confirmed. (Fig. 2.14). Compound LVI is known to be particularly susceptible to racemisation upon carboxyl activation, and its uncritical use is to be deprecated. Another related material also available commercially is Z His(τ Bzl)OH LIX (again described as "Im-benzyl"), and along with the pros-isomer XLVII prepared in this laboratory its structure was also confirmed (Fig. 2.15). The corresponding methyl esters Z His(τ Bzl)OMe and Z His(π Bzl)OMe LVIII were also examined, but with no extra data worthy of comment arising.

LVLVII[LVI]

a 5.80 %

b 2.20 % [1.20 %]

c 2.40 % [1.70 %]

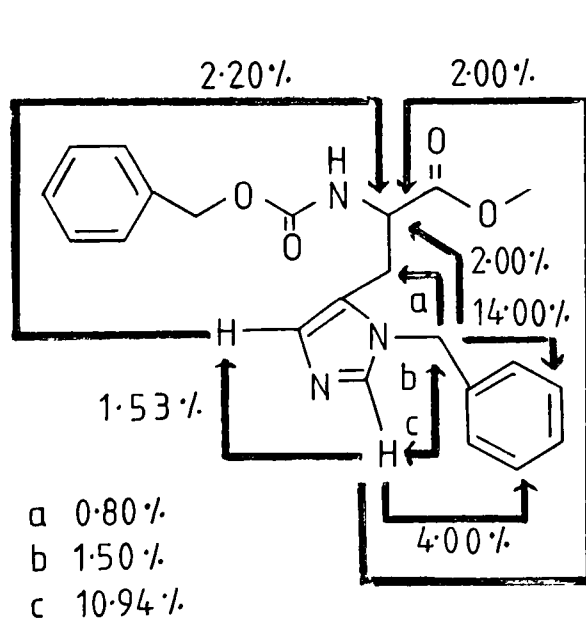
Fig.2.14

a 0.80 %

b 1.50 %

c 10.94 %

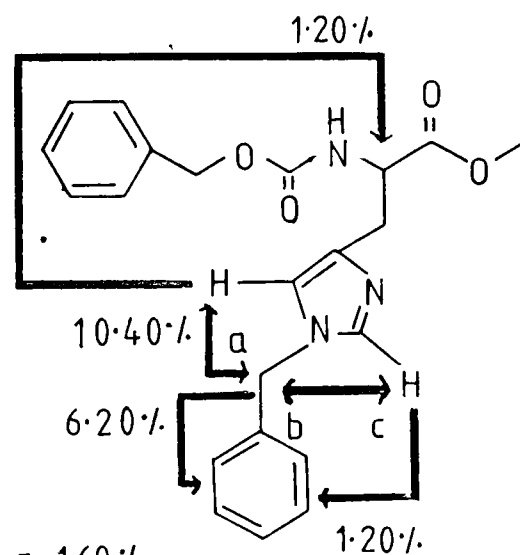
XLVII

a 1.60 %

b 1.70 %

c 13.60 %

LIXFig.2.15

Finally we returned to examine materials relating to the work described in Chapter one. It was mentioned there that hydrogenolysis of Z His(π Tom)OMe, LXVI was a satisfactory method of removing the Z-group; hydrolysis with alkali and aqueous methanol also proceeded smoothly over about 20 min. to give the free acid Z His(π Tom)OH LXI. Upon examination an n.o.e. was observed, from Im2, of both the methylene signals arising from the protecting group; confirming the structure. Boc His(π Bum)OMe LXII, prepared from LIV is also associated with the work in Chap.1, and was also examined, although this particular compound could have only limited synthetic utility. (Fig. 2.16).

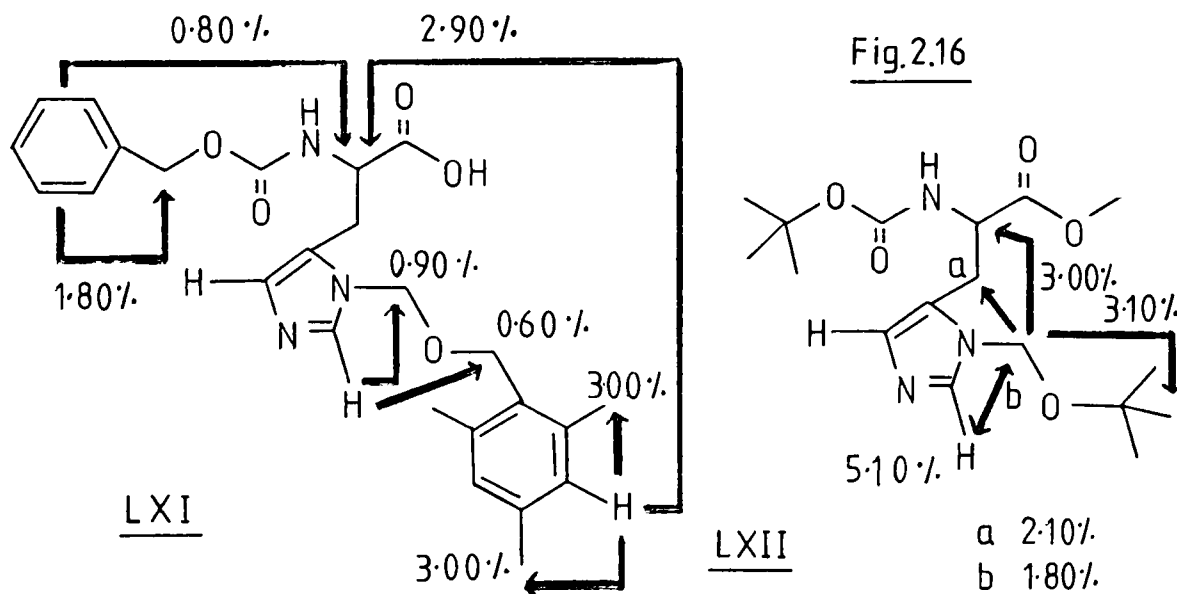

Conclusion.

The importance of regioisomeric differentiation in substituted histidines having been set out, and the inadequacies of existing differentiation techniques having been discussed, two new techniques are presented. The first of these, involving conversion to either of a pair of Im-methyl histidines, is a primary method suitable for firmly establishing the structure of histidine derivatives bearing all but the

very simplest classes of substituents (e.g. alkyl). The second is the application of an n.m.r. method suitable for quick examination of single novel compounds such as might arise in future work.

The twenty four compounds examined here range from well known commercially available materials assigned ambiguous names or incorrect structures, through to compounds still under investigation with a view to devising new methodologies for introducing histidine in peptide synthesis. The validity of synthetic methods used by other authors have been, in general, confirmed under rather closer conditions of scrutiny than they themselves were able to apply. The bulk of the work described in this chapter has been the subject of publication^{79,80}.

CHAPTER 3. Investigations into the protection of the guanidine
function in arginine.

Incorporation of Arginine into Peptides.

The basicity of the guanidino side-chain in arginine (pK 12.5; pI⁸¹ of the amino-acid at the isoelectric point 10.76) is such that in biological systems it is always protonated. It would remain in this form during most of the stages that could be envisaged during a peptide synthesis. There are however a number of drawbacks to "protecting" the functional group with a proton; for example it tends to make arginine-containing peptides soluble in water, and insoluble in organic solvents, hampering purification. In addition, the nucleophilicity of the group is not fully suppressed as would be the case in a simple amine. Experience has shown that this residual activity can lead to the formation of a number of by-products. For example, it was found that in attempting to couple Z Arg OH to H Pro OBu^t HCl by the BCCI-HOBT method, a compound containing a six-membered lactam ring was the major product⁸² (Fig. 3.1). Furthermore, acylation of the guanidino group during coupling can occur in preference to the desired attack at N^α.

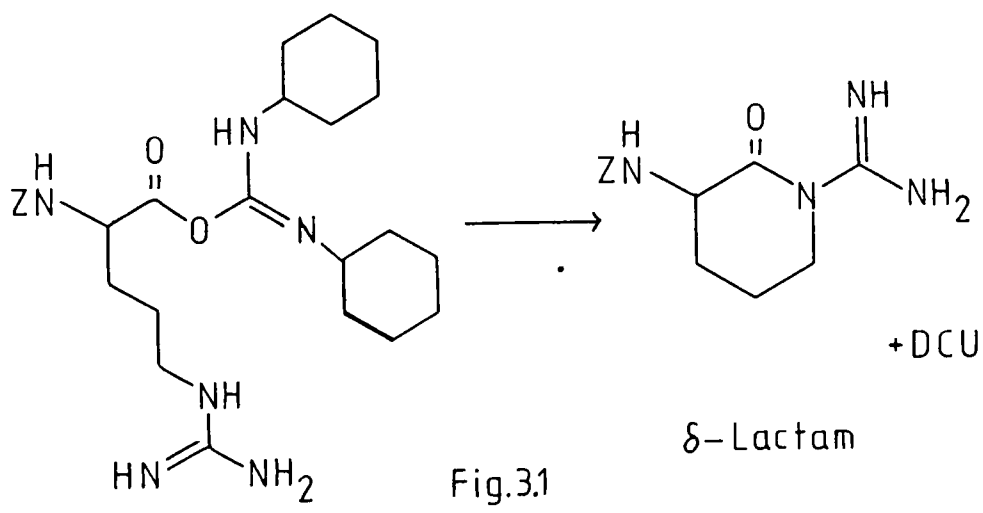

whilst attempting to deliberately prepare peptides linked through the side-chain, Photaki and Yiotakis⁸³ confirmed a previous observation⁸⁴ that the reaction does not terminate at this stage, but goes on to

produce a 2-iminoimidazolidin-4-one and an ornithine derivative, quantitatively, following deprotection (Fig. 3.2).

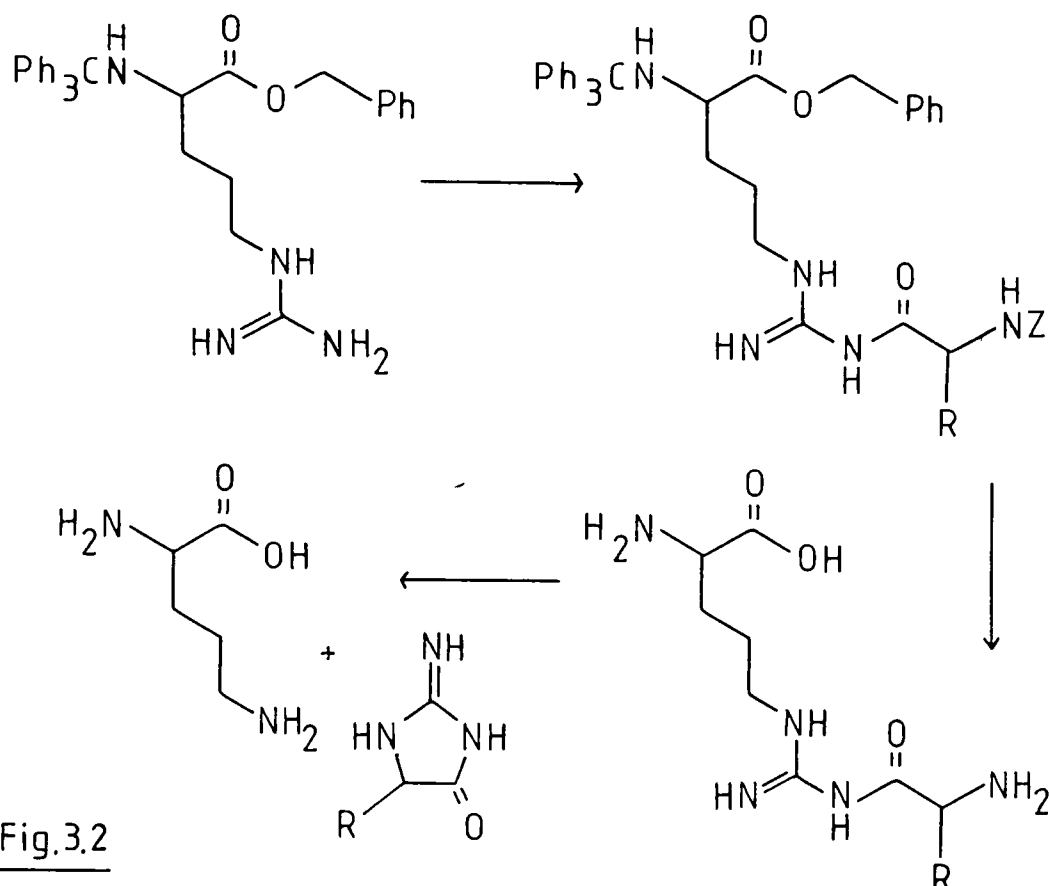
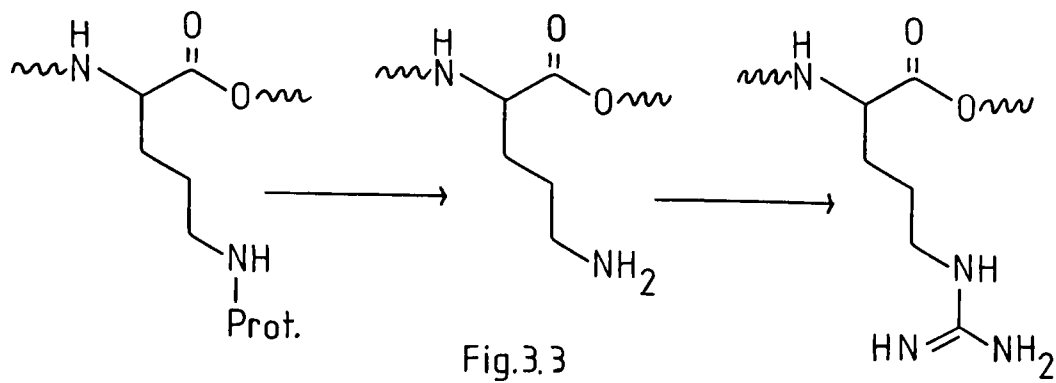

Fig.3.2

In fact the situation is even worse than the above simplified view, as there can be "side-reactions to side-reactions" producing both ω, ω' -diacylated derivatives, and mixtures of amino-amides and citrulline.

Before going on to discuss methods of protecting arginine in order to avoid these problems, the radically different approach of deliberately incorporating ornithine into the peptide and subsequently converting it to arginine must be mentioned. The reaction itself can be carried out using a number of reagents, e.g. cyanamide, guanidine, *S*-methyl isothiurea, *O*-methylisourea or the new aminoiminomethanesulphonic acid reagents recently developed by Miller⁸⁵ (Fig. 3.3). (Interestingly,



the reaction pre-dates the isolation of the amino-acid from protein sources in the 1890's, and is intimately tied up with the elucidation of the structure of arginine). However although a procedure for the differential protection of ornithine (as against lysine for example) is available,⁸⁶ the procedure has not attracted much interest aside from the work of the originators of the idea.

In examining potential arginine protecting groups we decided to continue to use a model compound, 2-phenylethylguanidine, LXIII, which we had previously found to be more convenient to handle than arginine itself.⁸⁷ The reaction above, in this case using β -methylisothiuronium hemisulphate as reagent, proved to be an easy means of preparation (Fig. 3.4).

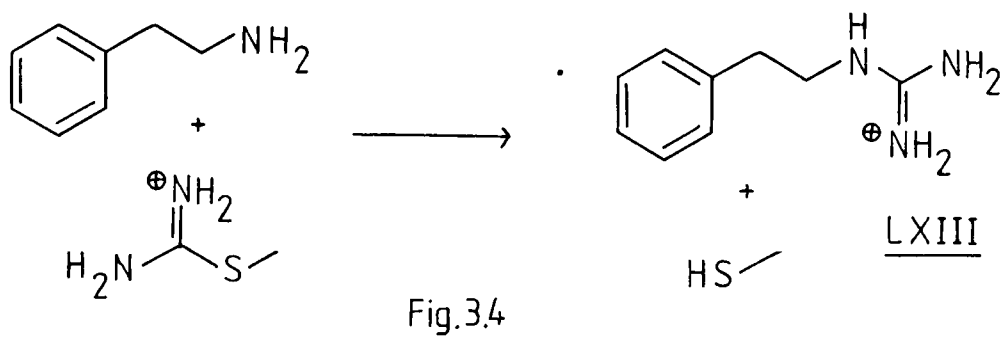

Arginine Protecting Groups.

Broadly speaking, the requirements for a guanidine protecting group, resemble those for an imidazole protecting group, set out in

chapter one, viz electron-withdrawing ability to reduce nucleophilicity, and/or steric bulk to hinder the approach of an electrophile. Useful spin-offs to be hoped for include good solubility in organic solvents, crystallinity of derivatives and, with respect to deprotection, orthogonality to other protecting groups. Obviously no single protecting group will be a panacea, as in making a choice, account must be taken of the particular conditions being used.

The structure inherent in the guanidine function also means the option of placing two identical (or different) protecting groups, or a bidentate protecting group is also available. (The fact that Trt Arg(δ -Trt ω -Trt ω -Trt)O₁Me has been prepared⁸⁸ shows there is literally plenty of room for manoeuvre). Naturally, numerous solutions to the problem have appeared over the years, and the area is periodically reviewed.^{89,90} In total around 40 different protecting groups have been put forward, falling into 7 classes (a - g, detailed below). However some of these have been presented as protecting groups, (e.g. see ref. 89 Table II), but in fact have no cleavage conditions, which is rather a contradiction in terms.

a). Nitro-group.

This group is the oldest and most commonly used, and is simple and cheap to introduce. It does however fail to suppress cyclisation; for instance in several attempts to prepare Z Arg(NO₂)O_p-NO₂Ph, the δ -lactam was formed⁹¹ and attempts to form an acid chloride were completely unsuccessful. It is also incompatible with the use of hydrazine. The most serious drawbacks arise during deprotection; removal by HF, methanesulphonic acid or fluorosulphonic acid is possible, but deprotection is normally by catalytic hydrogenolysis. This can be

sequence dependent and slow; the latter problem leading to reduction of aromatic residues elsewhere in the peptide. In common with other reductive methods such as Na/NH_3 and Zn/acid it can lead to the formation of substantial quantities of N^ω -amino and N^ω -nitroso arginines (in the last case up to 60%⁹²). The best use of nitro- is in the preparation of short sequences, where the use of catalytic hydrogenation is anticipated in the final stages of the synthesis. It was for this reason that it was chosen for the syntheses described in chapter four.

b). Acyl groups.

Around a dozen have been examined, including benzoyl, carboxybenzoyl, tetrachlorobenzoyl, N -dimethyltetrachlorophthalamyl, 2-benzoyltetrachlorobenzoyl, 2-isopropoxy-3,4,5,6-tetrachlorobenzoyl, O -sulphomethoxybenzoyl and dichlorosalicyl, and formyl, acetyl, trifluoroacetyl and dichloroacetyl. The benzoyl-derived groups were either completely resistant to cleavage, or were only partially cleaved by hydrazine, and this whole sub-class has been abandoned. Of the non-aromatic acyl groups, the first two were insufficiently electron-withdrawing; halogenation remedies this problem, but the resulting groups were too labile. This is unfortunate, as on N^ω , hydrolytic cleavage of trifluoroacetyl occurs on increasing the pH of the solution to around 10, using dilute aqueous sodium hydroxide or aqueous ammonia, conditions under which the peptide link is secure.⁹³

For the sake of completeness we decided to examine the remaining members of the series by preparing a derivative of the chloroacetyl and difluoroacetyl groups (Fig. 3.5). At the time of the original work the latter was a rather exotic and expensive material.

Neither attempt at functionalising the model guanidine gave a

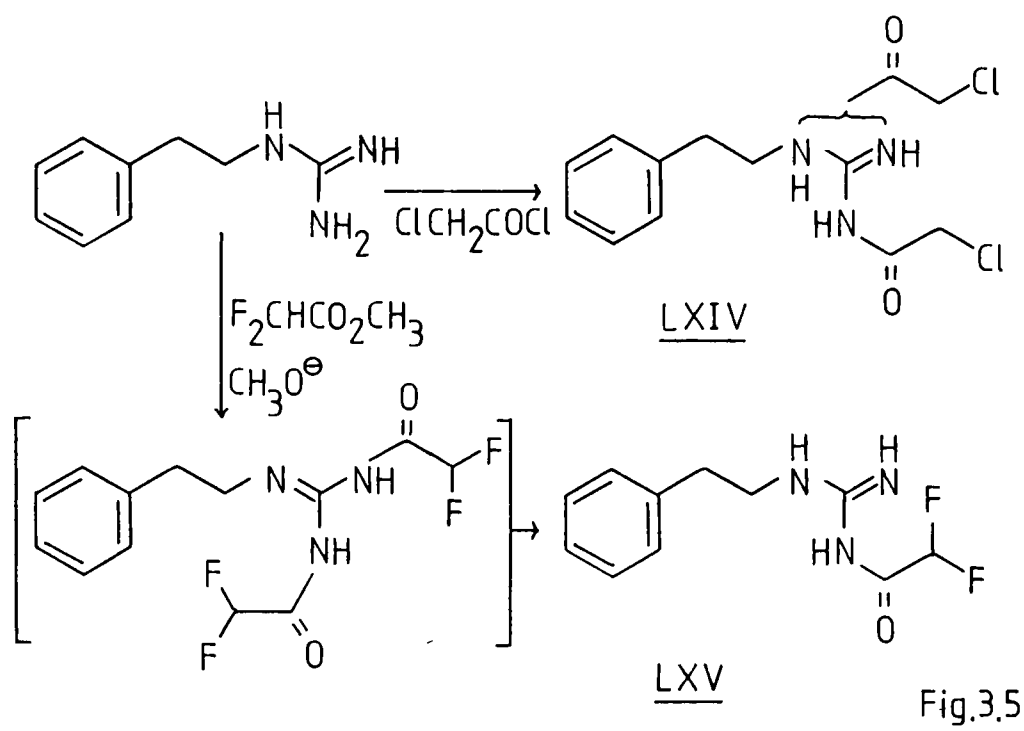

single product, and in both cases, but in particular with the ω -difluoroacetyl compound LXV, they were so noticeably unstable to hydrolysis that we could never envisage their use as protecting groups.

There is a possible unwanted side-reaction with this type of reagent, as exemplified in the diagram (Fig. 3.6)

We were deterred from investigating the last of the possible variants, fluoroacetyl, by its very high toxicity.

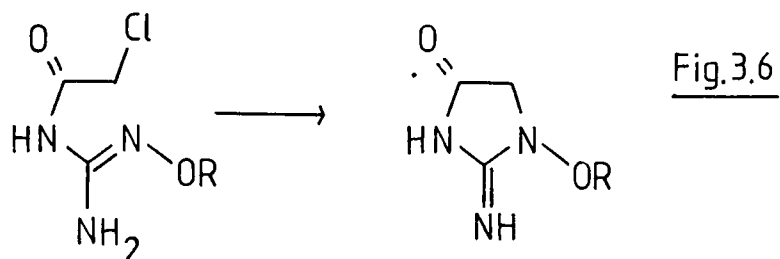

c). Urethanes.

There is more scope in deprotection amongst this class; the benzyloxycarbonyl group was of course investigated early on,⁹⁴ and found

removed by dilute HCl(aq) or by HBr in acetic acid, but is incompatible with hydrogenation, and presumably would be an unwelcome complication in the synthesis of sulphur-containing peptides.

e). The Trityl group.

As mentioned above, a tetra-tritylated arginine derivative can be prepared, but this is of no synthetic interest as the methyl ester cannot be hydrolysed. Boc Arg(Trt)OH has been prepared,⁹⁹ but has not yet been applied to peptide synthesis.

f). Sulphonyl groups.

The parent member of the group, benzenesulphonyl, has not found use in peptide chemistry, as it is too stable (it can be removed slowly by Na/AlH₃ or by Raney nickel¹⁰⁰). More useful protecting groups have been developed from it by variously substituting the aromatic ring. The tosyl group can be removed by Na/AlH₃ or by HF at 0°C, however the former can cause numerous side-reactions in peptides, including cleavage at proline, decomposition of tryptophan and methionine, racemisation etc, and is being increasingly shunned. Loading the ring with electron donating substituents which stabilise a developing positive charge, increases the susceptibility of sulphonates to acid cleavage, for example Tos is removed by TFMSA (1h.) and fluorosulphonic acid (20 min.). The newer groups; 4-methoxybenzenesulphonyl (Mbs), 2,4,6-trimethylbenzenesulphonyl (Mts), 4-methoxy-2,6-dimethylbenzenesulphonyl (iids) and 4-methoxy-2,3,6-trimethylbenzenesulphonyl (Mtr), are increasingly more labile to strong acid, but it was thought the limit had been reached when 4-methoxy-2,3,5,6-tetramethylbenzenesulphonyl was shown to be less labile than Mtr. However a reconsideration of the stereoelectronic reasons behind this lead to the development of what is perhaps the final step along this road, the 2,2,5,7,8-pentamethylchroman-6-sulphonyl group.¹⁰¹ In at least one of

the above examples (Hds)¹⁰² it has been pointed out that the reaction of Z ArgOH with Hds-Cl was not clean, and probably gave the analogue with two Hds groups, amongst several other by-products.

We wondered whether a bidentate sulphonyl protecting group, perhaps 1,2-benzenedisulphonyl (or 1,8-naphthalenedisulphonyl) would be useful, and set about preparing a derivative, LXVI, but no products of this type could be isolated from the reaction (Fig. 3.8). This was unfortunate, as one can envisage further substitution of the sulphonated ring to vary its properties

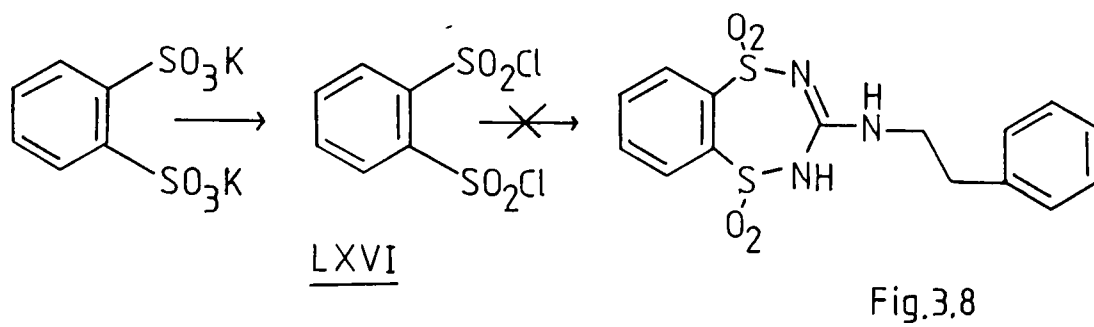

g). Bifunctional carbonyl groups.

During the 1960's a great deal of interest was generated when it was discovered that various aldehydes and ketones would react irreversibly with arginine in proteins. The resulting modified proteins permitted more selective cleavage by trypsin, sensitive quantitative assay for arginine, (using fluorescent ketones such as phenanthraquinone), immunological changes and other desirable effects. Amongst the reagents used were benzils, biacetyl, cyclohexane-1,2-dione, glyoxal and phenylglyoxal, 1,1,3,3-tetraethoxypropane etc, and the work from this period has been reviewed.¹⁰³ It has been claimed that some of the products are formed reversibly, but in general this is not the case. The more weakly held together adducts, such as that with cyclohexane-1,2-dione are rather too susceptible to pH changes¹⁰⁴ (Fig. 3.9) to be of

much use in straightforward synthesis, but have found a use in enzyme-catalysed semi-synthesis.¹⁰⁵

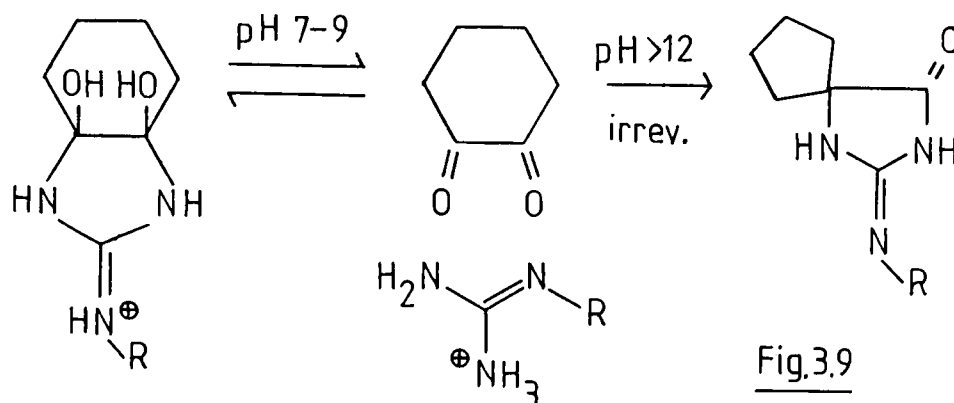

In a sense the whole investigation will probably repeat itself in the search for reagents to modify bases in oligodeoxyribo-nucleotide synthesis, as in the case of guanine¹⁰⁶ (Fig. 3.10).

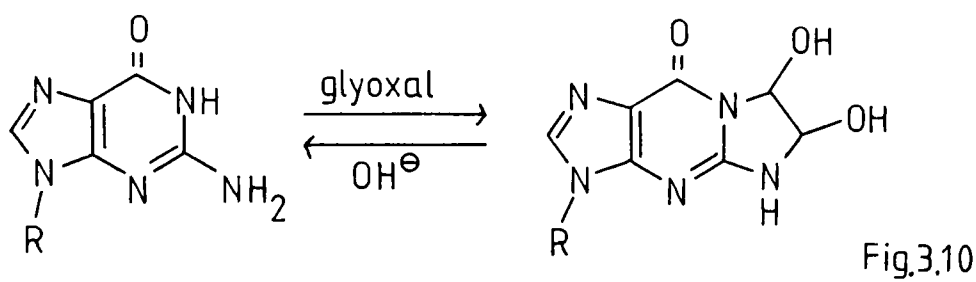

Further investigation of this class.

We felt there was a possibility of preparing a bidentate protecting group by working with compounds in class f)., above. Phthaloyl, the obvious, familiar example had been examined already. It cannot be cleaved completely, and removal by hydrazine leads to the formation of some ornithine. Malondialdehyde was also known to react irreversibly with guanidines to give 2-pyrimidylornithine derivatives (Fig. 3.11), however at this oxidation level there is no "lever" to re-open the ring.

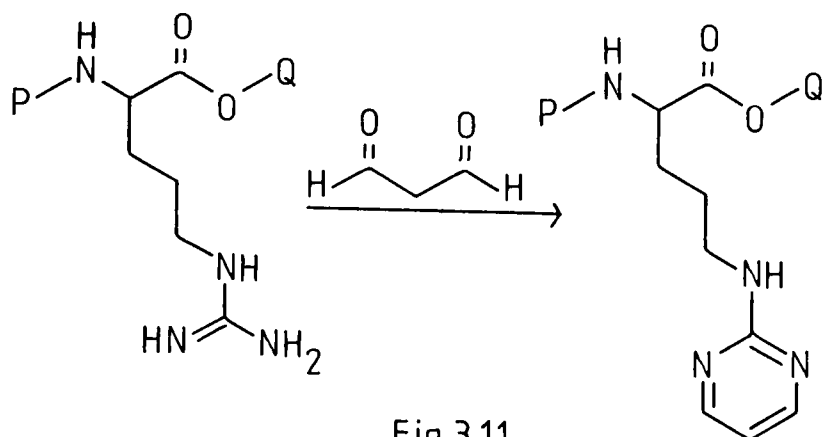

Fig.3.11

Taking the preparation of the barbiturates as a precedent, (e.g. diethylphenylmalonate and urea give 5-phenylbarbituric acid in the presence of sodium methoxide¹⁰⁷), we reacted diethyl malonate with our model guanidine and did indeed obtain a stable crystalline pyrimidinone derivative (Fig. 3.12). The reaction produced only a single isomer, as

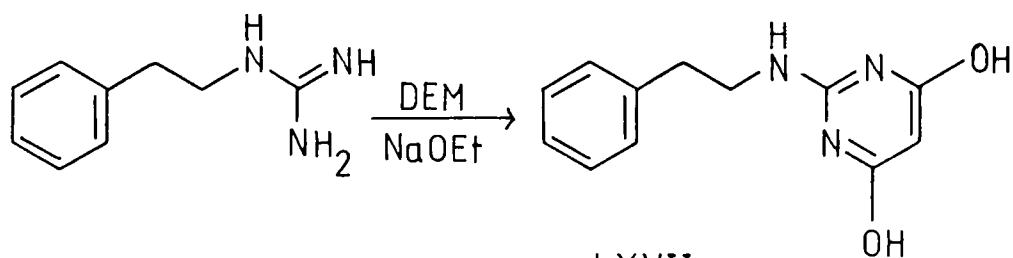
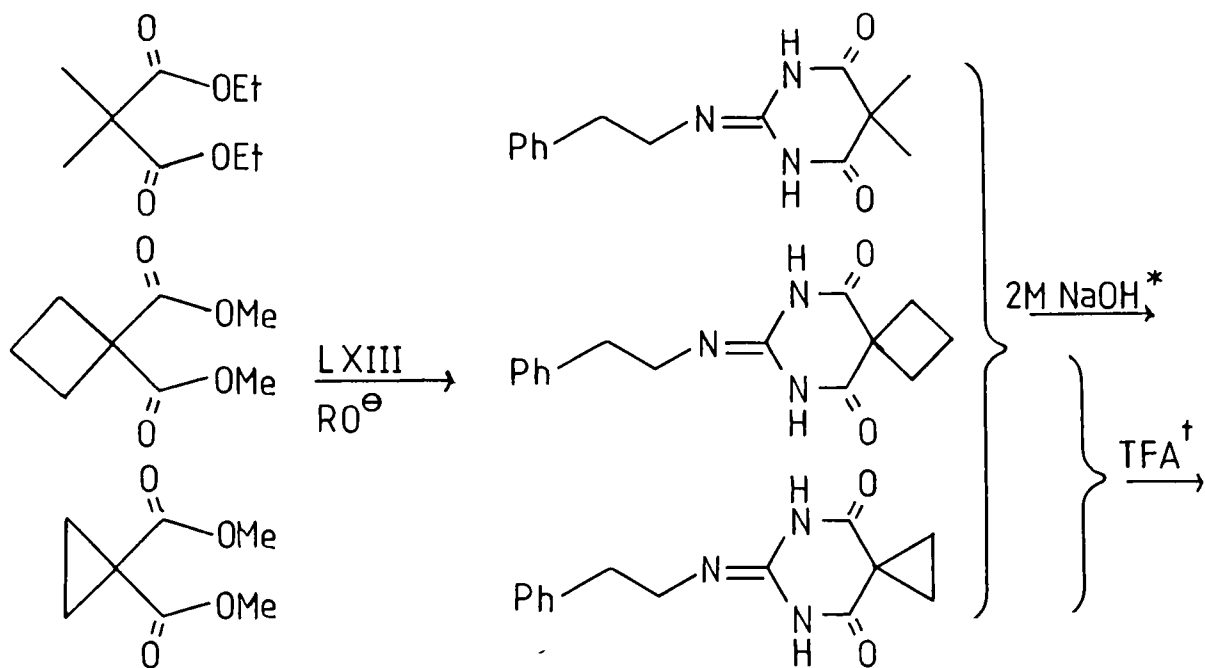

Fig.3.12

LXVII

indeed appeared to be the case in a subsequent reaction with a protected arginine derivative (Boc Arg OMe, LXIX, Fig. 3.13), though a trace impurity was present. This is as might be expected, as only the ω, ω' -derivative can be aromatic. However caution is necessary in making this type of assumption, as the reaction of DEM with methylguanidine has been reported¹⁰⁸ as giving two products in the ratio of 9:1 (Fig. 3.14).

Products such as LXVII and LXX are, being aromatic, so resistant to cleavage relative to other protecting groups, that their use can be completely ruled-out.



*Some guanine after 30 min. Complete hydrolysis- takes several days at RT.

†Decomposition to unidentified products.

Fig.3.15

Obviously, to increase the susceptibility of the pyrimidinone carboxyl to nucleophilic attack it would be desirable to place electron-withdrawing substituents on the 5-position. To examine whether such a product would form smoothly we reacted the readily available 2-phenyldiethylmalonate with our model guanine. We were of course assuming this would give another aromatic pyrimidinediol structure, but the availability of ^{13}C data on 5-phenylbarbituric acid¹¹² enabled us to check this assumption, or at least to establish to our satisfaction that bonds C(5) C(4) O(4) are in the enolic form, (Fig. 3.16), by analogy. (The compound A, having oxygen at C(2) is biased towards the keto form, as evidenced by these authors X-ray structure, whereas compound LXXVI, being an 2-imino compound, might be expected to be biased towards the two forms shown in the diagram).

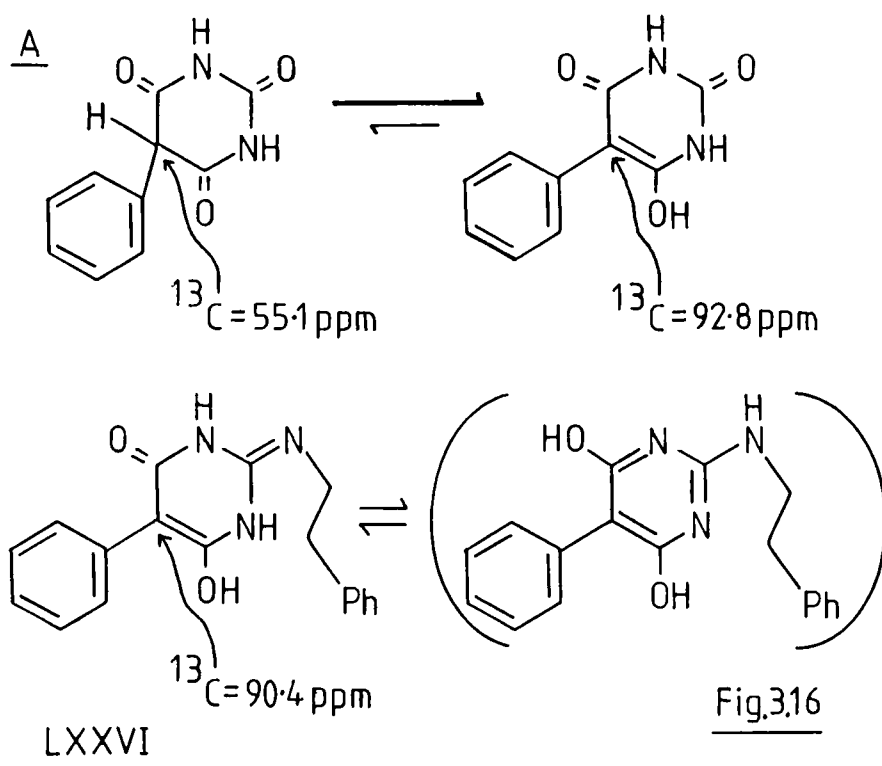

The 5,5-diphenyl derivative LXXVII is thus the material really required, and we attempted to prepare it as set out in the diagram (Fig. 3.17), but the only material that could be isolated was that resulting from loss of one of the carboxylate groups. Perhaps this is catalysed by a small amount of hydroxide ion present in the reaction. The same

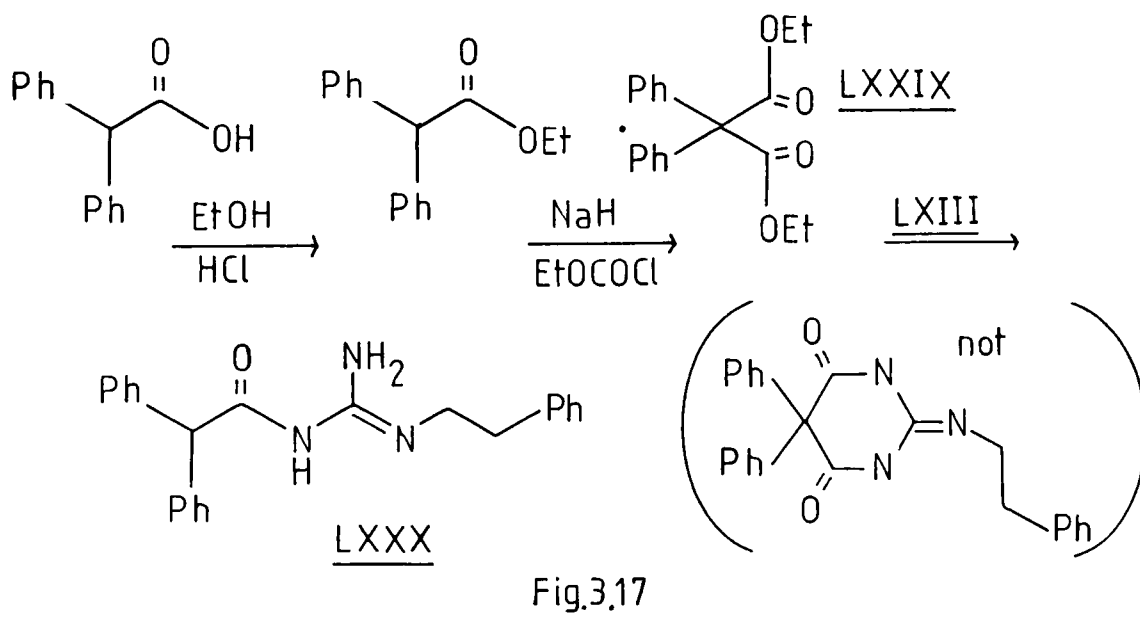

problem arose with the fluorenyl compound LXXXIII, which also failed to form (Fig. 3.13), instead giving the fluorenylcarbonyl compound LXXXIV. It could be that steric crowding around the 5-position is partly responsible for the facility with which the carboxylate function is lost, despite heating the reaction only briefly.

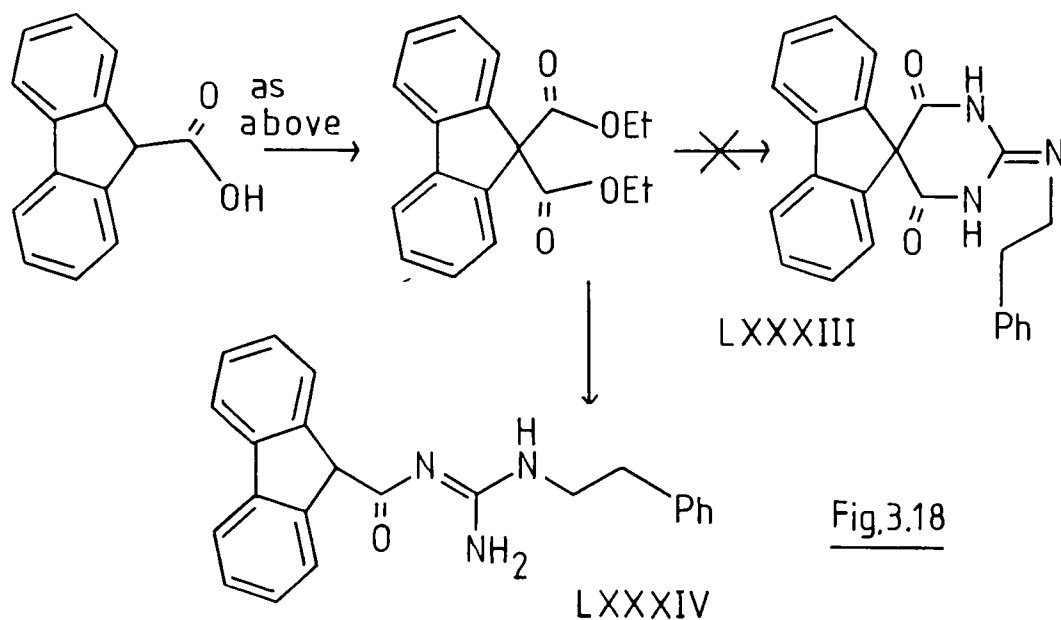

Fig.3.18

There are a number of other possibilities for modifying DEM at the 2-position; we prepared tetraethoxycarbonylmethane, but could not obtain any simple derivative from its reaction with the model guanidine. We considered dinitrodiethylmalonate, access to which has been described quite recently,¹¹¹ but which appeared rather hazardous.

Finally we decided to prepare 2,2-difluorodiethylmalonate LXXXV and 2,2-dichlorodimethylmalonate LXXXVII, as set out in the diagram (Fig. 3.19), and react them in turn with the model. Preparation of LXXXV from DEM proceeded smoothly to give a material essentially free of other fluorinated by-products. Introduction of the first halogen atom was essentially instantaneous, but the second step proceeded rather more

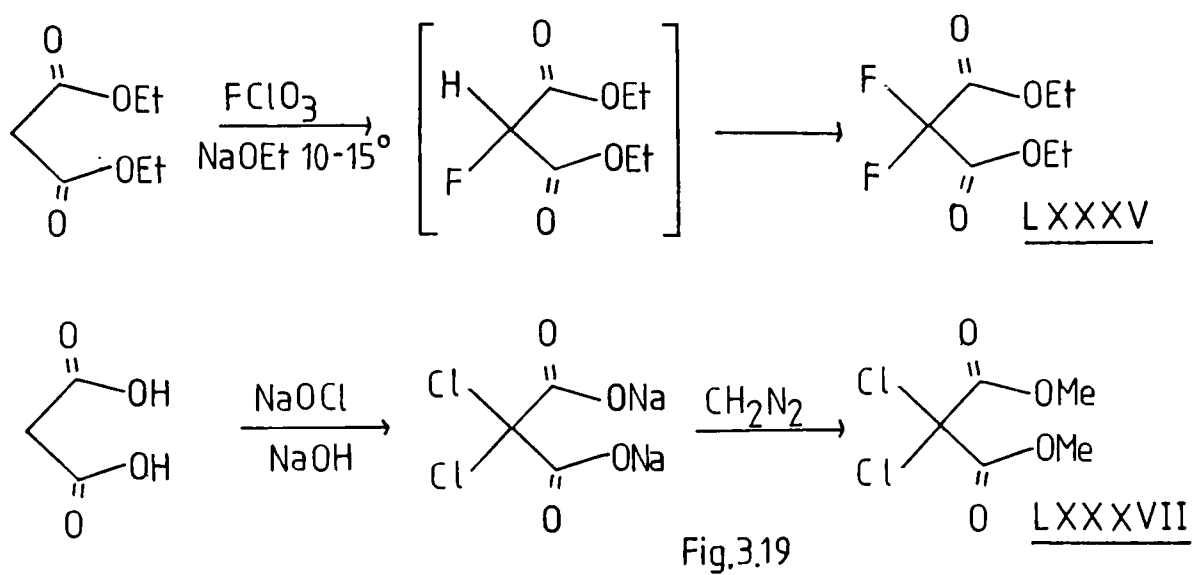

Fig.3.19

slowly. Preparation of LXXXVII caused more of a problem, and had to be carried out in a round-about manner. Reaction of the model guanidine with LXXXV gave a reasonable yield of 2-(2-phenylethylamino)-5,5-difluoropyrimidin-4,6-dione LXXXVIII, but when an attempt to recrystallise the latter from ethanol was made, the ring was opened to give N-(ethyl-2,2-difluoromalonyl)-N'-phenylethylguanidine, IXC (Fig. 3.20). As this material was also formed when LXXXVIII was allowed to

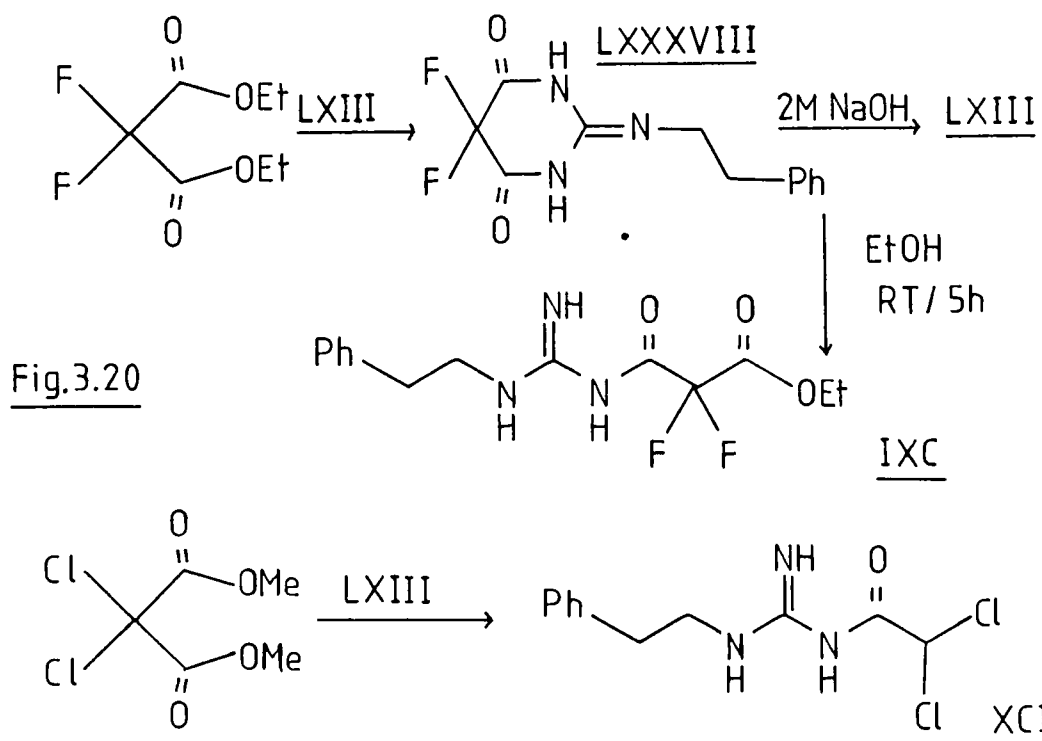
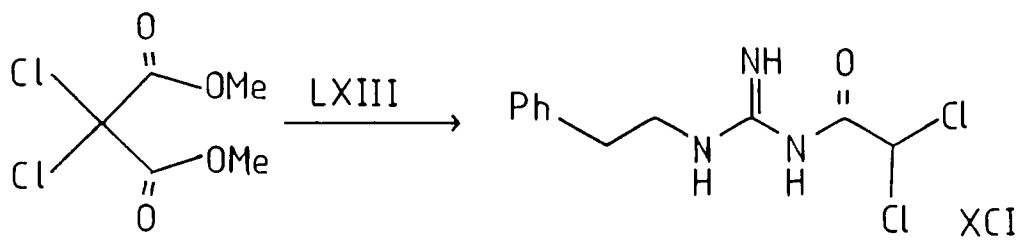

Fig.3.20



stand for a few hours in ethanol, it would appear that the material is rather too prone to solvolysis. Nevertheless we examined the effect of various nucleophiles on it, and indeed with aqueous sodium hydroxide (2:1) the starting guanidine was released in only a few minutes. Reaction with both hydroxylamine and methylamine gave, in addition, other unidentified materials after several hours.

Reaction of LXIII with LXXXVII gave not the 5,5-dichloropyrimidine derivative XC, but instead N-(2-phenylethyl)-N'-dichloroacetylguanidine, which parallels the behavior of the 2,2-diaryl compounds discussed above. This is particularly unfortunate as one could envisage deprotection methods particular to the chloride such as the use of sulphur/nitrogen containing bidentate deprotecting groups (Fig. 3.21).

Fig.3.21

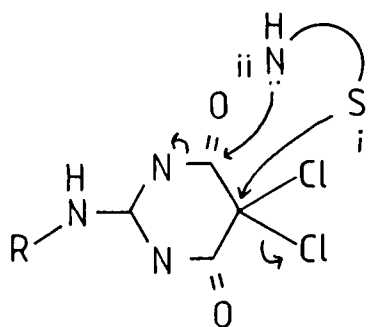

A general conclusion about this pyrimidine-type of bidentate protecting group can be made: on the positive side they are, as predicted, cleavable by nucleophiles. Additionally we did not seem to be troubled by the mixtures of δ,ω and ω,ω compounds, even with the more stable 5,5-dialkylpyrimidine - diols, that bedevil workers trying to disubstitute with monofunctional reagents. The problem which has not been surmounted is how to obtain finer control of the lability of the derivatives; in passing from compounds LXVII through LXVIII to LXXXVIII we go in turn from complete stability, through resistance to hydrolysis

to frailty. Perhaps one could combine contrary effects and prepare a malonate of less symmetry, but with intermediate electronic properties, such as 2-fluoro-2-methyldiethylmalonate. The work in this chapter really closes the door on monofunctional halo-acyl groups, but leaves some options open with respect to the bifunctional reagents.

CHAPTER 4. Preparation of some imidazole and guanidine containing tripeptides as potential angiotensin converting enzyme inhibitors.

Preparation of some potential ACE inhibitors.

In searching for a potential inhibitor one is initially disinterested in specificity towards any particular dipeptidase, so the first synthetic targets will naturally be of minimum tolerable length, i.e. tripeptides. Basing our attempt at receptor-fitting on the requirements of the enzyme set out in the introduction, (in particular figure 6), we selected H His Phe Arg OH XCIX, as the initial target. This sequence places the imidazole and phenyl rings in close proximity (as in the natural substrate; --- Pro Phe His Leu OH), and maintains the imidazole ring in a position where it is likely to interact with the zinc atom. The substrate tolerance of ACE towards bulky, often N-containing residues at the C-terminal suggested the presence of a large pocket here, but a pocket known to be intolerant of negatively charged groups, (terminal diacids make very bad substrates). Hence a bulky basic group (Arg) seemed desirable. Retention of the C-terminal acid is mandatory, but there ought to be a great deal of flexibility at the N-terminus, at least with respect to size if not functionality.

Preparation of the tripeptide required protection of the basic side-chains, and we selected nitro-protection for the guanidine (despite its drawbacks it is still an acceptable choice for small peptides), and π -benzyloxymethyl-protection for the imidazole. Anticipating a penultimate hydrogenolysis step to remove these two groups, it was reasonable to protect the carboxy-terminus by means of its benzyl ester, which group being readily removed under these conditions. The synthesis was then carried out in the manner set out in Fig. 4.1.

The sequence -- His Phe Arg-- has been prepared previously, but in partially protected form, en route to a larger peptide; the methods

of protection (H^+ on Arg and π -Bzl on His) we now regard as completely superseded.

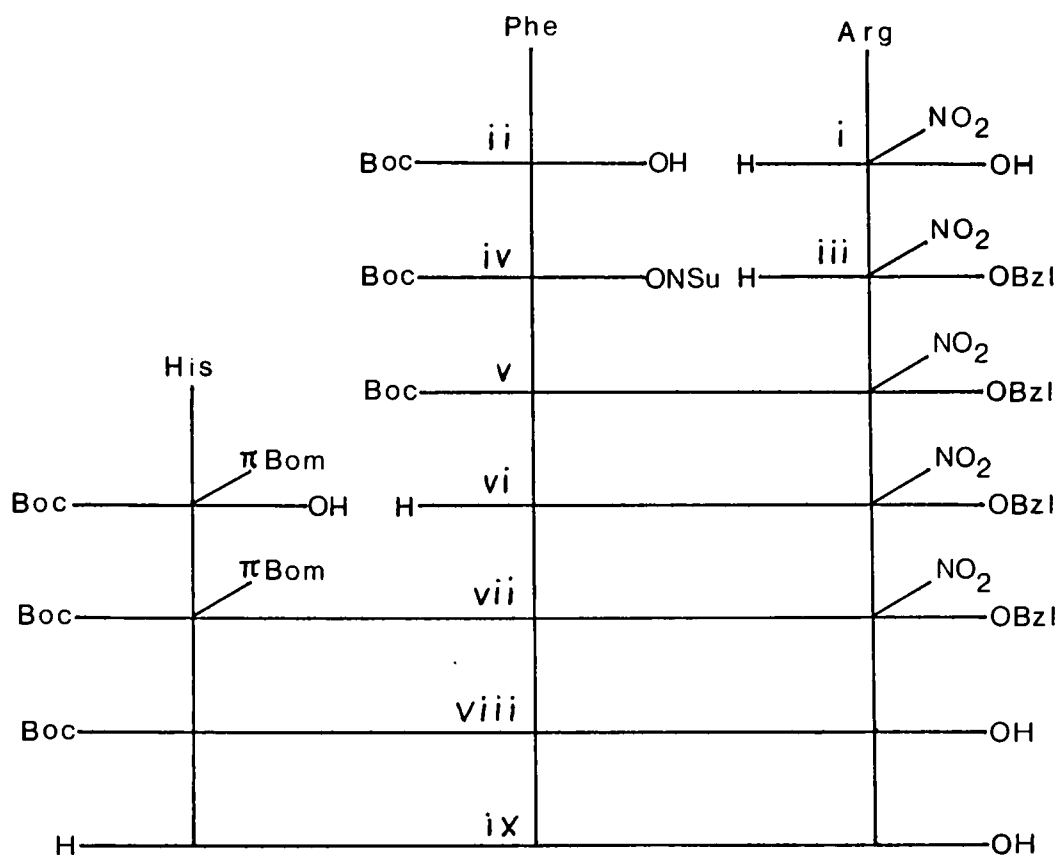

i), HNO_3 , H_2SO_4 , (60%). ii), 0.5M NaOH, Boc_2O , (68%). iii), Bzl OH, $p-CH_3C_6H_4SO_3H$, (70%). iv), NSuOH (82%). v), Et_3N (73%). vi; vii), TFA; Et_3N , HOBT, DCCI, DMF (52%). viii), H_2 , 10% Pd/C, (79%). ix), TFA (97%).

Fig.4.1

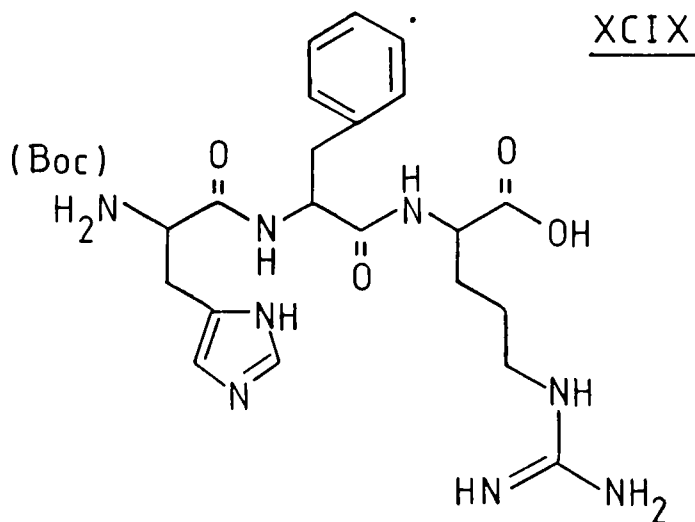

There were no notable difficulties with the above; at step iv (Fig. 4.1.) the trichlorophenyl ester was prepared in addition to the N-hydroxysuccinimide ester, but was found to be less convenient at step v. The final product appeared to be homogeneous. The methodology was definitely superior, in this particular instance, to that using Bum-protection on the histidine, as described in chapter 1. Additionally it supplied us with an N-terminal-protected analogue at the penultimate stage;

Boc His Phe Arg OH XCVIII.^v

These tripeptides and the further examples below were difficult to handle, but characterisation was carried out by the normal methods; they were not large enough to merit amino-acid analysis. Melting points are quoted, but as the compounds described are acetate salts with water of crystallisation they are probably not of great value. High field n.m.r. spectra were obtained on all the deprotected products, so it was possible to assign each peak to a class of proton (e.g. α CH) and in some cases to a specific residue. More detailed work is not required. Using the FAB technique enabled the molecular ion or its protonated form to be identified in the mass spectrum.

The extent to which intermediates were characterised depended on their novelty; familiar literature compounds have only a minimum of confirmational data quoted, though the proton n.m.r. of every compound was in fact examined.

At this point we needed to establish that the compounds were substrates of ACE, and our biological collaborators¹¹⁴ used the method originated by Cushman et al¹¹⁵ and well described later. A peptide, Bz Gly His Leu OH can be used as a surrogate of the natural substrate, and the rate of its hydrolysis by ACE can be observed by measuring the spectroscopic absorption of the hippuric acid produced. In the

presence of the test substance at concentrations between 10^{-3} and 10^{-6} M the percentage inhibition may be measured. This can be taken as a reasonable measure of competitive inhibition as the binding constants of this tripeptide (Bz Gly His Leu, $K_m = 2200 \mu$ M), are similar to those of angiotensin I, bradykinin, and BPP_{5a} (H Glu Lys Trp Ala Pro OH), and to the dipeptide products (which to some extent themselves act as inhibitors)¹¹⁶. An additional factor of crucial importance is that the rate of cleavage of angiotensin I by ACE is greatly enhanced by the presence of chloride ion, whereas that of bradykinin is enhanced to a much lesser degree. In general the greatest activation by chloride ion appears to occur with substrates that bind weakly to the enzyme. In fact the cleavage of strongly bound inhibitors such as BPP_{5a} are actually inhibited by chloride ion. It has been shown that chloride induces a conformational change in ACE.¹¹⁷ The assays were therefore repeated in the absence of chloride, where cleavage of the surrogate tripeptides proceeds at a much lower rate (10 fold drop). The reason for this particular interest in chloride ion is that in the kidney its concentration is very low, so one might envisage selective hydrolysis of bradykinin versus angiotensin I, and a consequent hypotensive effect occurring in vivo.

A separate experiment was performed to establish whether the test substances were themselves substrates of the enzyme, and this was confirmed.

The figures for H His Phe Arg OH show an inhibition of 10% at a concentration of 10^{-3} M, and in the presence of chloride ion 21% at 10^{-5} M. Thus there is a drop in selectivity towards the normal substrate as the rates are enhanced. (Bz Gly His Leu OH itself is known to show a 1300% increase in its rate of hydrolysis in the

presence of chloride). The corresponding figures for Boc His Phe Arg OH, XCVIII, were 35% at 5×10^{-4} M. (11% at 10^{-5} M with chloride). This level of activity is poor, and compares with the very modest inhibitory powers of, say, succinyl proline, with IC_{50} of 3.3×10^{-4} M. A powerful inhibitor such as captopril has an IC_{50} of 2×10^{-8} (variously reported 3.4×10^{-8} to 2.9×10^{-9} M), under similar conditions in the presence of chloride.¹⁶

The comparable activities of XCVIII and XCIX agree with the assumption that there is great steric tolerance at the N-terminal.

Given that XCIX is a substrate, the next logical step was to modify it so it could not be easily hydrolysed between the histidyl and phenylalanyl residues, but not so much as to disturb the general shape excessively. Introduction of a methyl group on the amide nitrogen, hindering the approach of nucleophiles and strengthening the bond, was proposed.

The modified amino-acids of this type have been prepared by Benoiton¹¹⁸ (In the course of work wherein he refuted the supposed stability of N^{α} -methylated amino-acids to racemization). Our initial

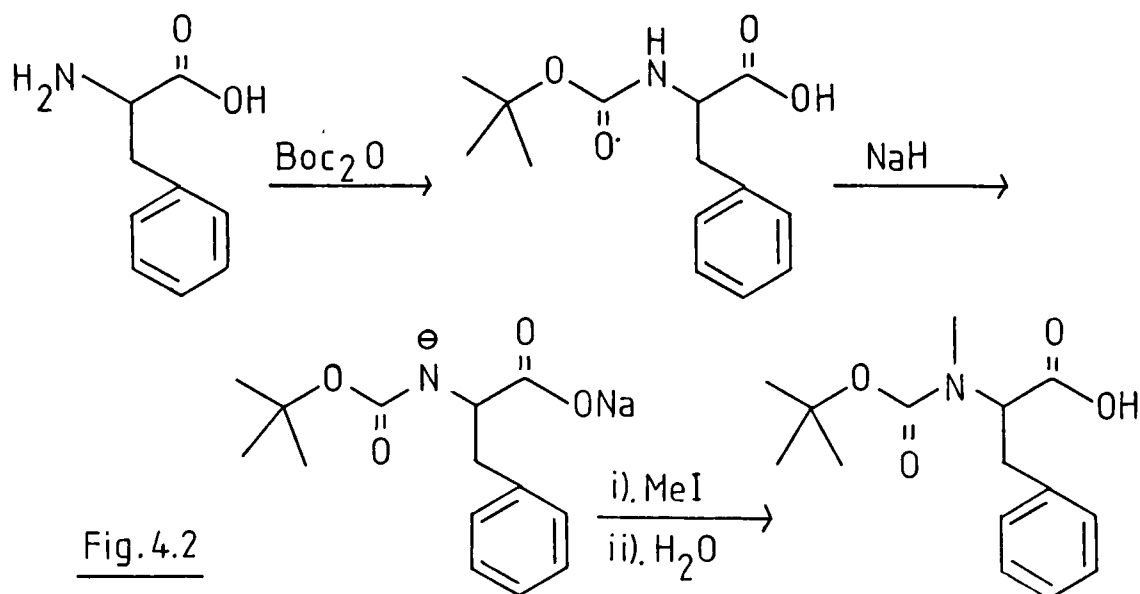
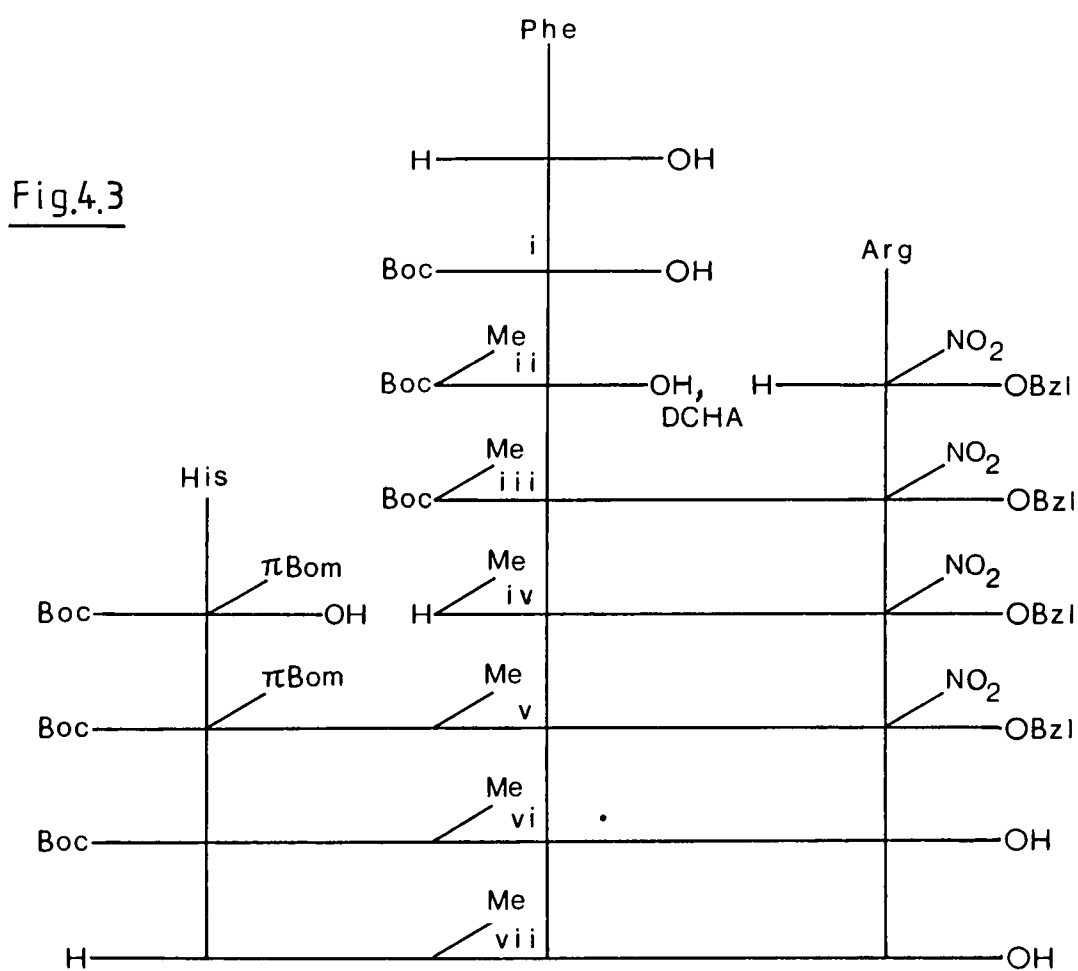

Fig. 4.2

attempt to prepare Boc Ile Phe OH using commercial Boc Phe OH met with complete failure. Closer inspection of the literature showed that the above author had met with similar difficulties. Repetition of the reaction with freshly prepared and carefully dried reagent however gave a respectable yield of the required material (Fig. 4.2). Synthesis of the tripeptide II His Ile Phe Arg OH, CIII, then proceeded in a satisfactory manner using the methodology previously described, and set out in the diagram (Fig. 4.3).



i). As previously. ii). NaH, MeI, THF, (65%). iii). HOBT, DCCI, DMF, (79%), iv). TFA, (99%). v). HOBT, DCCI, DMF, (53%). vi). H₂, 10% Pd/C, AcOH, (75%). vii). TFA; Amberlite IRA 45 (OAc), 71%.

l...

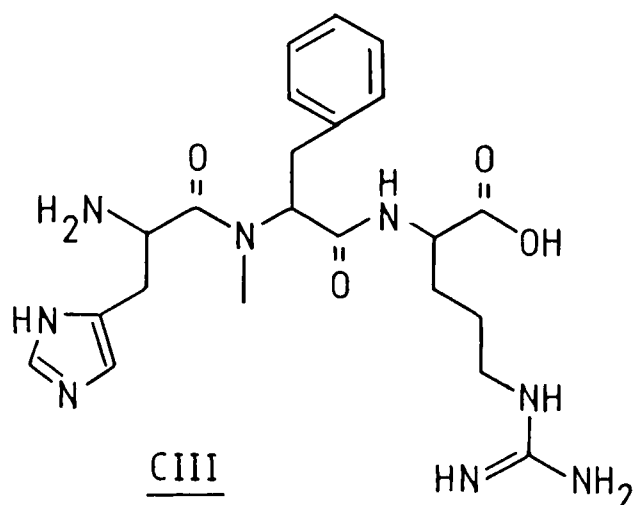
Fig.4.3

The product did not show, unfortunately, any inhibitory effect against ACE at a useful concentration of 10^{-6} M. The assay procedure was then repeated without the normal pre-incubation with the standard peptide, in the presence of chloride, and examined using ACE derived from two different sources, the rat and the dog. The figures of 13% at 10^{-4} M and 4% at 10^{-4} M respectively were still too low to be of interest. Clearly the enzyme is intolerant of steric interference about the site of scission.

We next set about lengthening the whole molecule in the hope of bringing the imidazole moiety in closer proximity to the zinc. This can be achieved by homologation of the phenylalanine. In doing this the pK_b of the phenylalanyl- N^α is reduced and the position of the side-chain is altered, but we hoped neither of these changes would be to the detriment of the binding. Homologation of phenylalanine was carried out by the Arndt-Eistert procedure; it has been known for some time that the Wolff rearrangement of diazoketones with a chiral centre adjacent to the carbonyl group proceeds without appreciable racemization (Fig. 4.4).

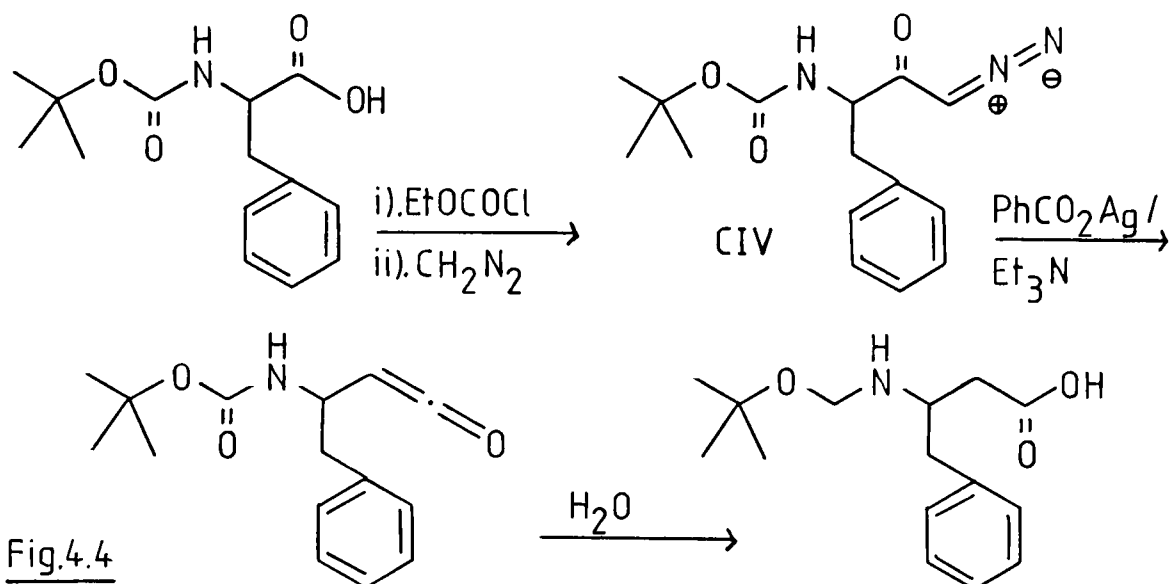

The required diazoketone, CIV crystallised from hexane in good yield, and appeared to be quite homogeneous. However the melting point was 30°C higher than that of the literature,¹¹⁹ by which we could only conclude that the material previously reported was contaminated. Recently this has been investigated more thoroughly and an explanation has been advanced that the materials were contaminated with their corresponding methyl esters.¹²⁰ A peculiar water/diazomethane adduct (Fig. 4.5) has been suggested as the mechanism by which this forms; whatever the explanation we encountered no problems when using carefully dried diazomethane. The Wolff rearrangement proceeded

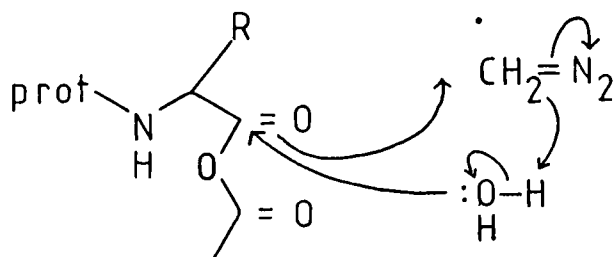

smoothly, using a little freshly prepared silver benzoate in triethylamine as a catalyst, to give the protected β -homoamino-acid CVI. This was converted to its β -hydroxysuccinimide active ester and

incorporated into the synthesis of tripeptide CXI by the previously described methodology (Fig. 4.6).

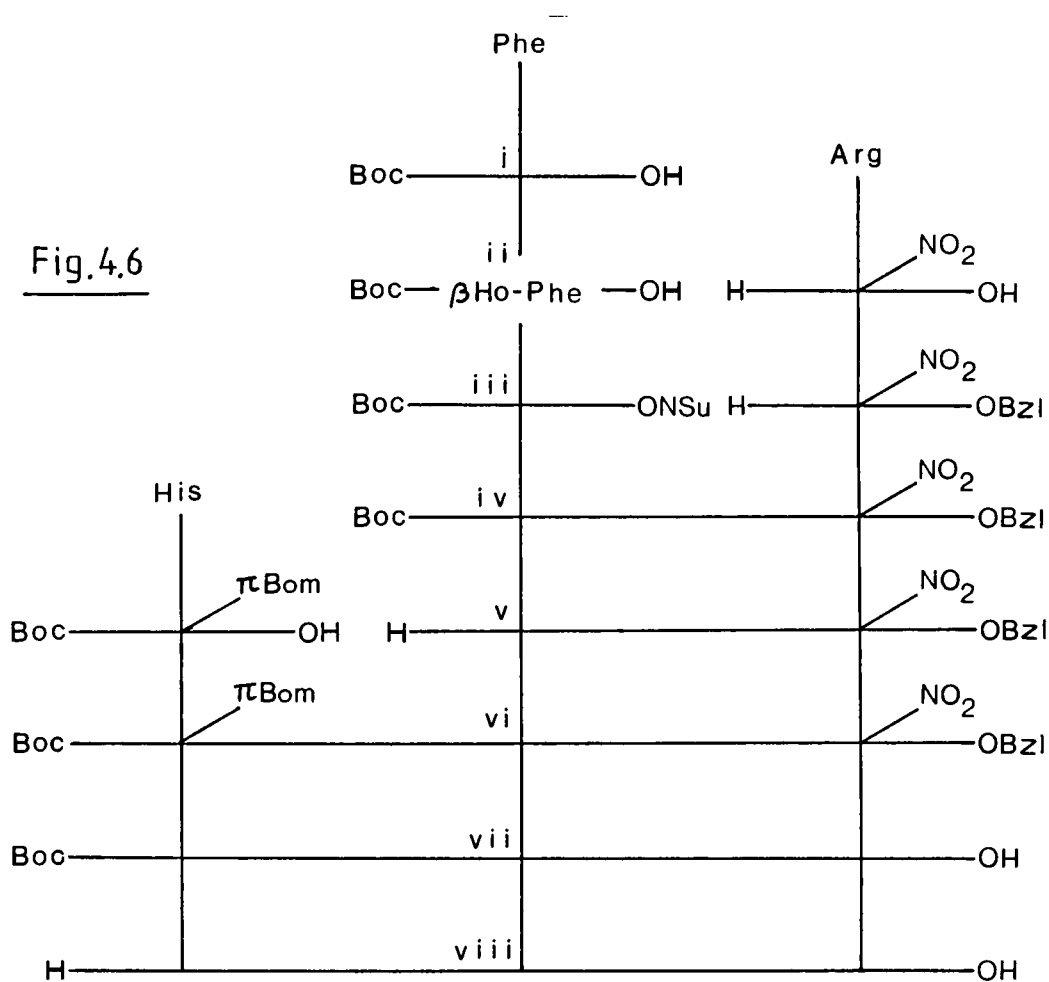

i) As previously. ii). EtOCOCCl , CHN_2 ; PhCO_2Ag , MeOH; H_2O , OH, (70%; 52%; 73%). iii). NSuOH, DCCI, (43%). iv). Et_3N , dioxan, (94%). v). TFA, (99%). vi). DCCI, HOBT, DMF, (78%). vii). 10% Pd/C, 80% AcOH. viii). TFA; Amberlite IRA 45 (OAc), (52%, vii inc.).

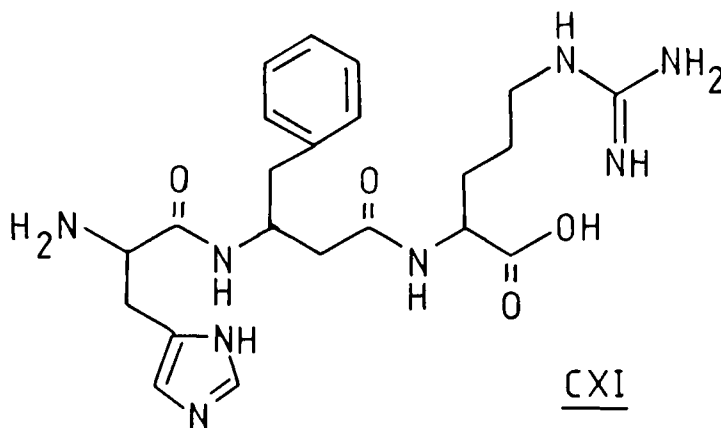

The product, II His β Ho-Phe Arg OH CXI, showed the highest activity of any of the compounds tested, with 11% inhibition at 10^{-6} M (rat) and 7% at 10^{-6} M (dog), chloride present. The corresponding figures without pre-incubation being 49% at 10^{-4} M and 39% at 10^{-4} M respectively. This is however still below a level meriting further investigation, which is rather a pity as the precedent, work replacing Phe and Pro in bradykinin by their corresponding β -amino-acid analogues,¹²¹ had shown some (but not all) natural enzyme systems can be inhibited in this way.

Work on the action of angiotensin II on its receptor, whereby the phenylalanine at position 8 was replaced by cyclohexylalanine had shown some interesting results:¹²² in that work it appeared that the cyclohexyl ring might have been able to partially mimic the aromatic ring of phenylalanine, but once the receptor had been occupied, the peptide no longer acted as an agonist. We reasoned that a cyclohexyl analogue of KCIX might perhaps still bind to ACE, but sufficiently distort its structure to prevent hydrolysis or fragment release. Cyclohexylalanine was available prepared by exhaustive hydrogenation of phenylalanine.¹²³ It was incorporated routinely into the required tripeptide II His Cha Arg OH CXV (Fig. 4.7). This procedure was thought preferable to deliberate "over-reduction" of KCVII, which is a comparatively slow process in similar examples.¹²⁴

The level of ACE inhibition was low; 6% at 10^{-6} M (rat), 3% at 10^{-6} M (dog) (without pre-incubation 11% at 10^{-4} M and 13% at 10^{-4} M respectively).

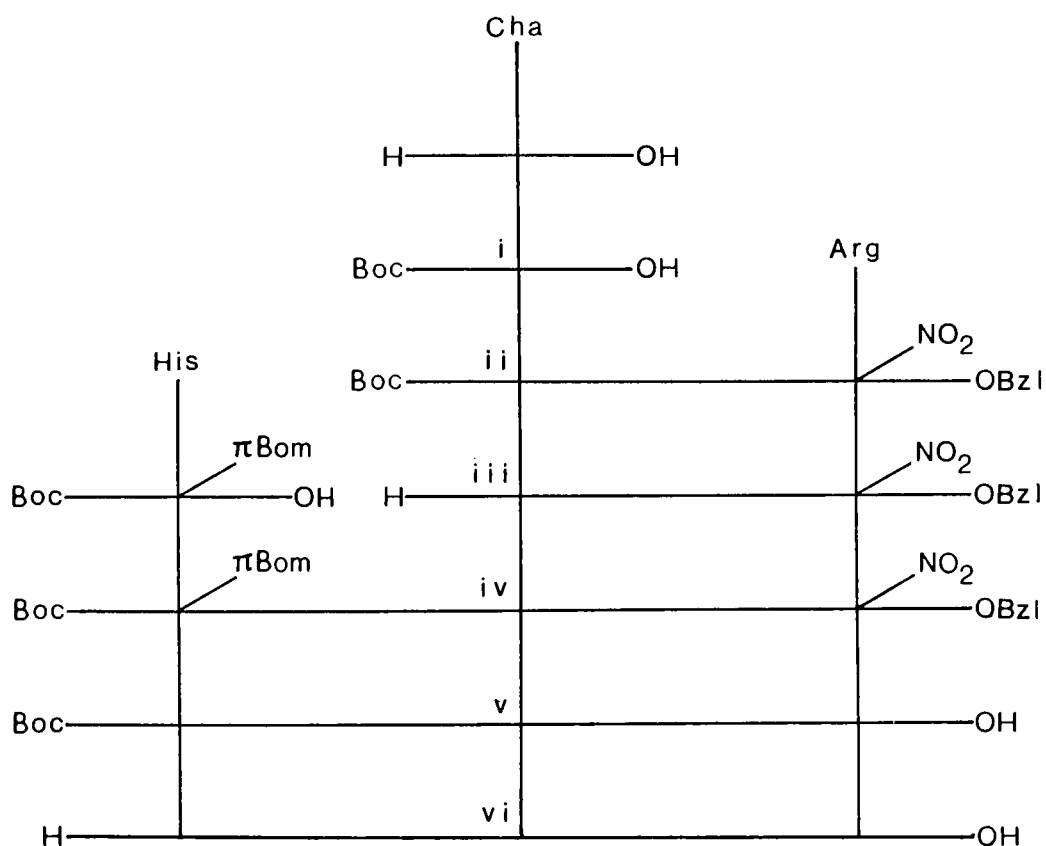

i), 1M NaOH, Boc_2O , (87%), ii), Et_3N , DCCI, HOBT, DMF (60%), iii; iv), TEA; Et_3N , DCCI, HOBT (74%). v; vi), H_2 , 10% Pd/C, TEA, (42%).

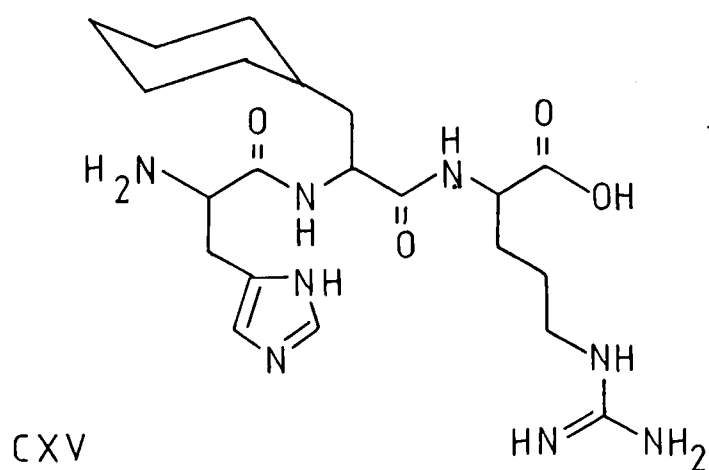
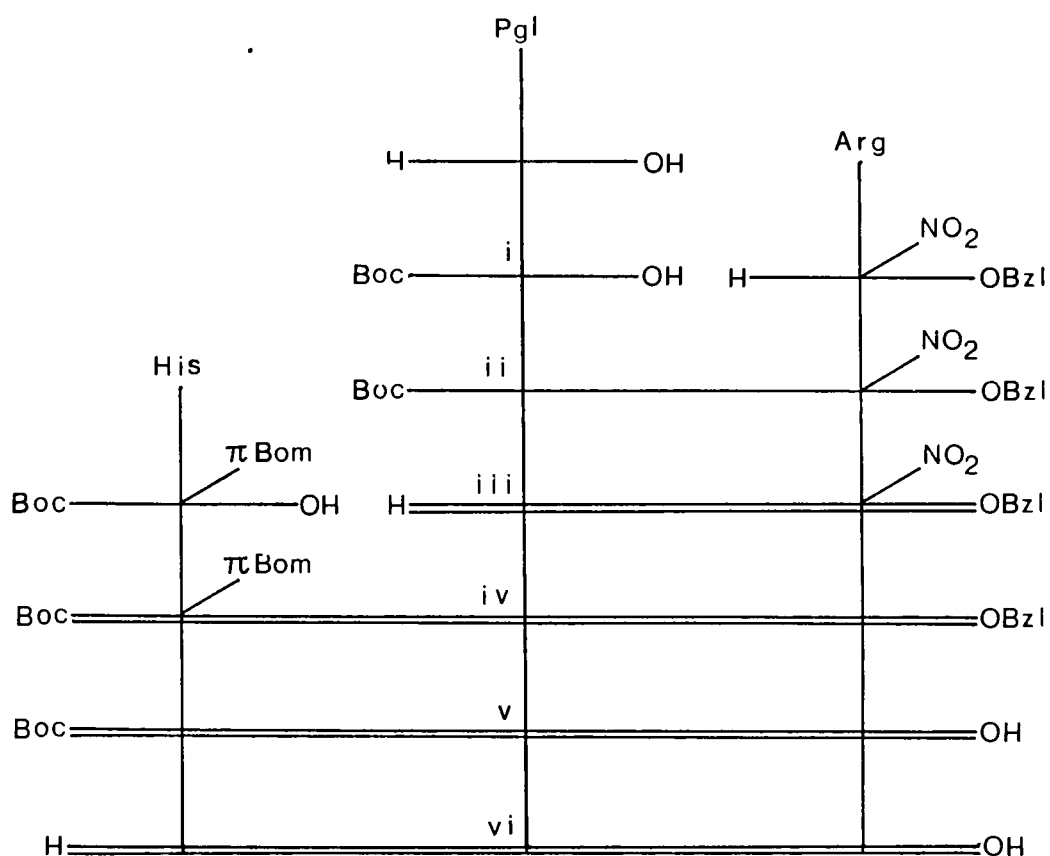

Fig.4.7

The final variant involving modification of the phenylalanine moiety was that with the β CH_2 removed; there was a possibility that

the aromatic ring was being pushed too hard into the pocket receiving it. Starting the preparation of the tripeptide from D, L-phenylglycine immediately gave a mixture of diastereoisomers after the first coupling, which could not be separated at this stage, or subsequently. Despite a poor yield following chromatography at one stage (Fig.4.8. iv), it



i), 1M NaOH, Boc_2O (99%). ii), Et_3N , HOBT, DCCl, (32%). iii; iv), TFA; Et_3N , HOBT, DCCl, (95%). v), H_2 , 10% Pd/C, (92%). vi), TFA (76%).

Fig.4.8

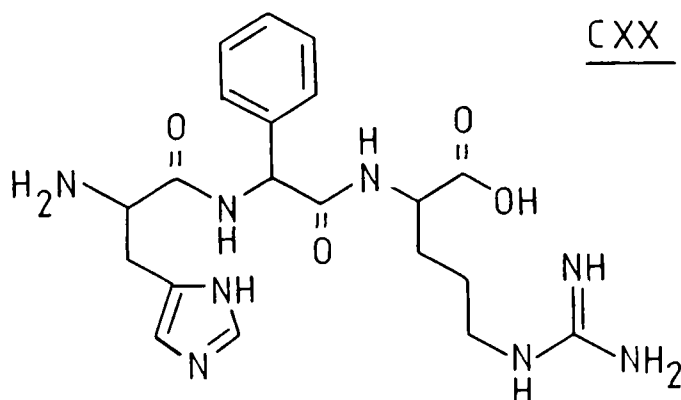

appeared the diastereoisomers were present in equal amount, here and to the end of the synthesis. In the n.m.r. spectrum of the final product, histidylphenylglycylarginine, CXK, several pairs of chemically (but not stereochemically) equivalent protons' signals were easily distinguished (e.g. Im 2; 8.82 and 8.90 δ).

By the time of synthesising CXK the attention of our collaborators had been drawn to a second enzyme, renal endopeptidase (REP), discussed below; the supply of compound was therefore diverted to this use and not tested for ACE inhibition. The data relating to REP is given in the table below (Fig. 4.12).

As the point of scission in the tripeptides is between His and Phe, modification of the histidine moiety was a reasonable next step. Removal of the N-terminal amine function would indicate whether this has any influence on binding versus ACE. The first target was then des-amino-histidylphenylalanylarginine, CXKII. The commercial availability of urocanic acid made the synthesis particularly short and economical (Fig. 4.9)

The conditions of the penultimate hydrogenolysis step common to all the tripeptide syntheses also hydrogenated the double-bond in the

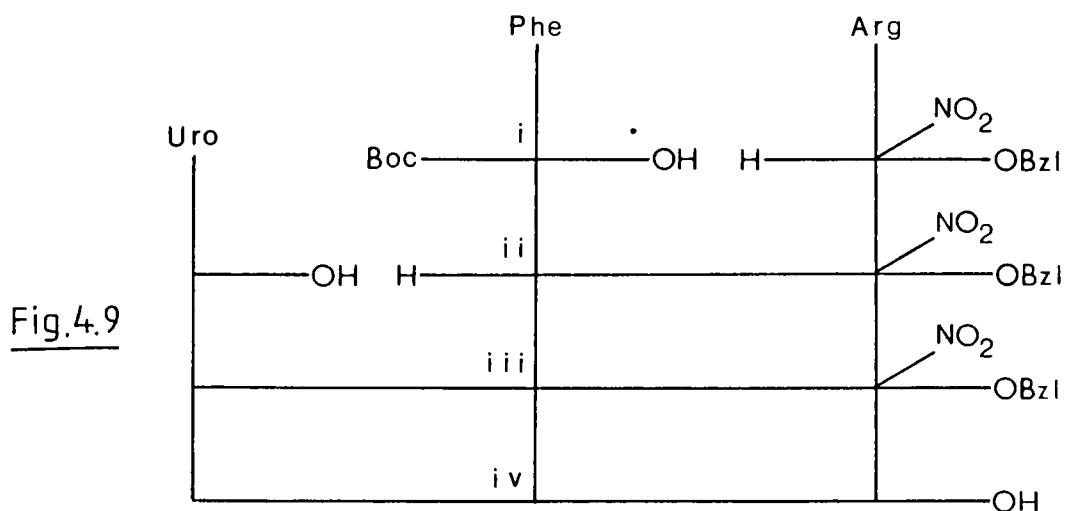

i), ii) As previously, iii), HOBT, DCCl, DMF (80%) iv), 10% Pd/C (48%).

urocanyl-peptide and left a des-amino-histidyl peptide (fig. 4.10).

The product, CXXII, was however less active than the parent tripeptide NCIX, with 14% inhibition of ACE at 10^{-4} M (rat).

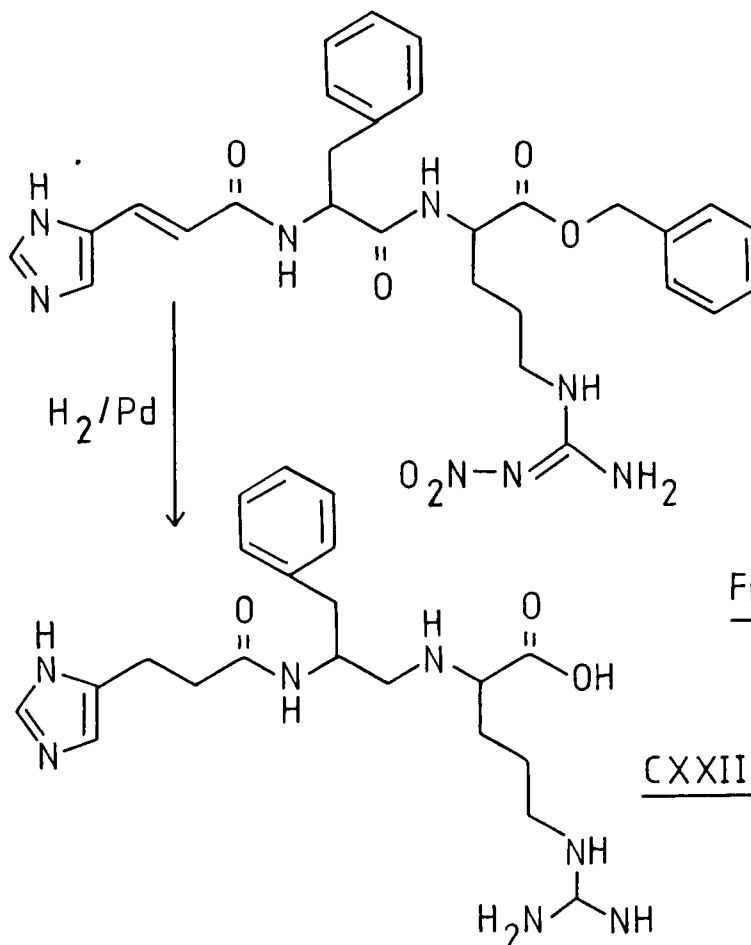

Our final attempt at preparing a histidine variant on the tripeptide, reported here, is that of β -homohistidylphenylalanyl-arginine. Of the homologues of histidine, α -homohistidine is known and has been used in pharmaceutical research before, but β -homohistidine, where the additional methylene group is inserted in the side-chain, is not, and would be of general interest. Conventional attempts at homologation (e.g. reduction to the alcohol, displacement of a tosylate by cyanide etc) in this laboratory had failed. Starting with

the previously described protected histidine derivative Z His (π Bua) OH, III an attempt was made to prepare the corresponding diazoketone by analogy with the preparation of CIV. However none of the desired material could be obtained; a small quantity of a material which appeared to be a methoxy-methylketone was obtained, and there was some mass-spectroscopic evidence that the chloromethyl ketone was present.

Classically, preparation of amino-acid-derived diazoketones is carried out on N^{α} -phthaloylated derivatives so that there are no positions available for side-reactions to occur, such as methylation. The preparation of such a compound, N^{α} -phthaloyl- N^{π} -benzyloxymethyl-histidine, XXXIV has been described in chapter 1, and an attempt was made to prepare the diazoketone from it, again via activation of the acid using ethyl chloroformate. Unfortunately no diazoketone was isolated, only a little ethyl ester presumably derived from the breakdown of the mixed anhydride (Fig. 4.11). It was not then possible to proceed to the Wolff rearrangement.

The synthesis was abandoned by us at this stage, but one could envisage alternatives, for example the reaction of trialkylsilyldiazomethane with acid chlorides, followed by reaction with alcohol, has been introduced as a new type of Arndt-Eistert reaction.¹²⁵

Our collaborators had taken an interest in renal Endopeptidase (endopeptidase 24.11) which is an ectoenzyme capable of hydrolysing regulating peptides at the surface of many different cell types. Although it is located in the intestine, lymph nodes, salivary glands, spinal cortex, corpus striatum etc, it was felt to be worthwhile interfering in its action as its level of activity at these sites is only around 1% of its activity in the renal cortex.¹²⁶ Isolation of the enzyme has enabled an assay to be prepared, using Bz Gly The Arg OH

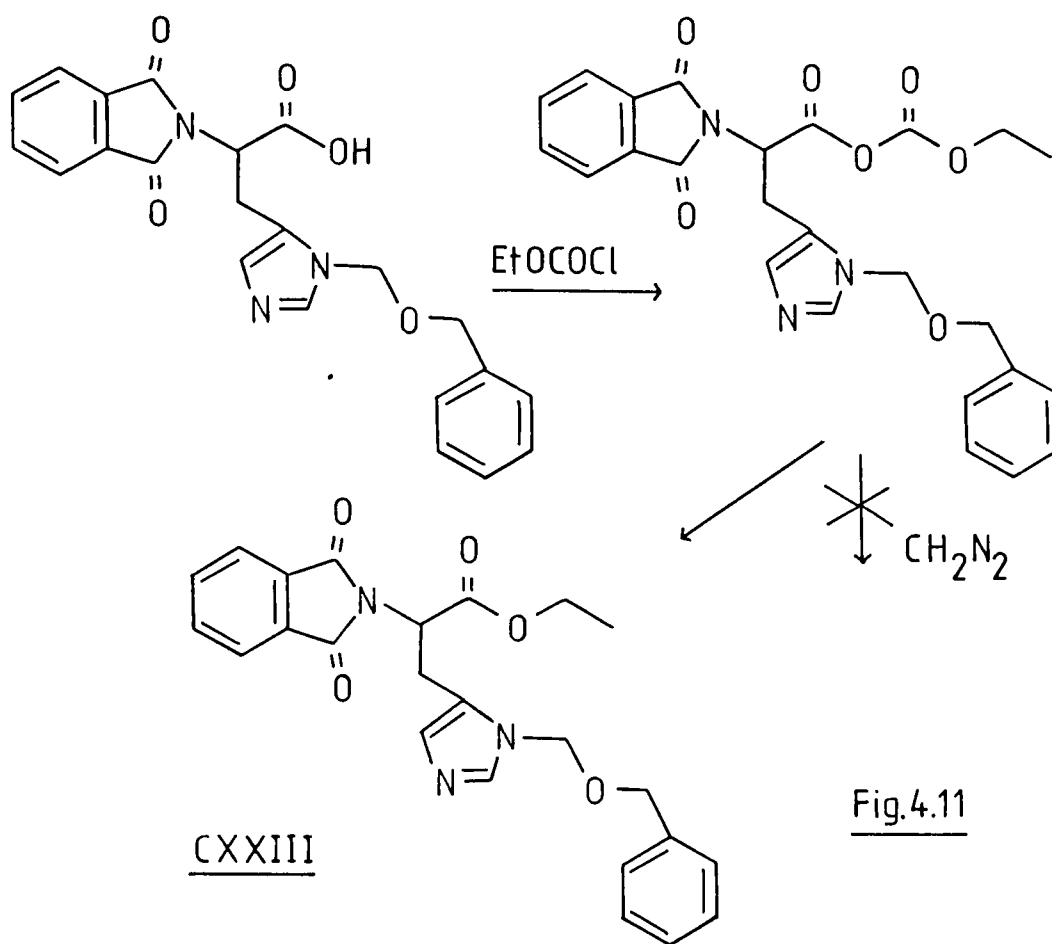

as the standard substrate. The results are presented in the table (Fig. 4.12).

A useful level of activity is an inhibition with the concentration in the region of 5×10^{-8} M – 10^{-10} M, and it can be seen that none of the substances tested would have an activity at this level, and are not suitable for further investigation.

Compound	% Inhibition against REF	% Inhibition without pre-incubation.
<u>XCIK</u>	14 at 10^{-3} M (6 at 10^{-5} M without Cl^-)	-

Fig.4.12 /...

<u>ECVIII</u>	63 at 5×10^{-4} M (1 at 10^{-5} M without Cl^-) (IC_{50} 2.5×10^{-4}).	-
<u>CIII</u>	0 at 10^{-6} M	0 at 10^{-4} M
<u>CKI</u>	0 at 10^{-6} M	15 at 10^{-4} M
<u>CKV</u>	0 at 10^{-6} M	0 at 10^{-4} M
<u>CKX</u>	87 at 10^{-4} M (IC_{50} 1.5×10^{-5})	-
<u>CKXII</u>	0 at 10^{-6} M	5 at 10^{-4} M

Fig.4.12Conclusion.

Overall the biological results presented in this chapter, though occasionally informative, show a level of activity below that at which further modification of the basic structure could be considered worthwhile. With hindsight one might have been more conservative in the choice of C-terminal residue: perhaps using tryptophan or proline (though the latter has been to a great degree "worked out"). However from the standpoint of chemical synthesis and the further exemplification of histidine protection the preparations described are quite satisfactory.

EXPERIMENTAL

APPARATUS AND MATERIALS.

MELTING POINTS. Measurements were taken using a Kofler block hot stage, and are uncorrected.

INFRARED. Spectra were recorded on a Perkin-Elmer 257 instrument, 4000-600 cm^{-1} .

OPTICAL ROTATION. Measurements were taken using an Optical Activity AA-100 automatic polarimeter.

MASS SPECTRA. m/z measurements were carried out by Dr R. Aplin and his staff on a V.G. Micromass 16F or 30F

G.C.H.S. Analysis was performed using a Perkin-Elmer-Sigma 3B using 2m X 4mm column, 3% OV-17 at 100°C.

NUCLEAR MAGNETIC RESONANCE. Proton spectra were recorded on a Brücker WM300 instrument. Meteronuclear spectra were recorded using a Brücker AM250 instrument. Proton spectra recorded using a Hitachi-Perkin-Elmer R24B operating at 60MHz were adequate for a few of the simpler compounds.

ELEMENTAL ANALYSIS. The majority were carried out in the laboratory, but we also acknowledge the assistance of the analysis department of the University of Manchester.

CHROMATOGRAPHY. Flash chromatography was performed on Merck Kieselgel 60F. Centrifugally accelerated chromatography was performed on a Harrison Research Chromatotron, in u.v. transparent solvents under an inert atmosphere. Gel permeation chromatography was carried out using Pharmacia Sephadex materials on gravity-fed columns; detection was by means of ultra violet absorption and optical rotation measurements.

Analytical chromatography was carried out using Merck silica gel coated plastic or aluminium sheet, using the following eluents:-

H:E	Hexane/Ether, ratio given	
A3	nBuOH/AcOH/H ₂ O	4:1:1
B1	CHCl ₃ /MeOH/AcOH	7:1:1
C1	Pyridine/nBuOH/H ₂ O	7:7:6
C1	CHCl ₃ /MeOH/880 NH ₃	2:2:1
F2	CHCl ₃ /MeOH/AcOH	10:2:1
E3	CHCl ₃ /MeOH	4:1
L4	CHCl ₃ /MeOH	9:1

Detection of normal compounds was by u.v. absorption, iodine, 5% sulphuric acid in ethanol or 1% dodecamolybdophosphoric acid in acetone, as appropriate. Detection of peptides was by 2% ninhydrin in ethanol, Sakaguchi reagents and Pauly reagents, depending on the nature of protecting groups.

SOLVENTS.

Hexane, Methanol, Petrol and Water were distilled.

Acetic acid, Acetic anhydride, Acetaldehyde and Formamide were of analytical grade.

Dimethylformamide was distilled under vacuum from calcium hydride.

Tetrahydrofuran was distilled from sodium and benzophenone.

Benzene, Dioxan and Ether were dried over sodium.

Triethylamine was distilled from phenylisocyanate.

Ethanol was absolute as supplied by Burroughs Ltd.

Constant boiling HCl was of "Aristar" grade.

Other solvents were of general laboratory grade.

CHAPTER 5. Preparation of reagents of the general class ROCH_2Cl and their reaction with histidine derivatives.

t-Butoxymethylthiomethyl ether. IV.

Initial procedure. t-Butanol (50 ml, 520 mmol), dimethyl sulphoxide (300 ml) and acetic anhydride (200 ml) were mixed and allowed to stand at R.T. during 150 h. The mixture was poured into a saturated solution of sodium hydrogen carbonate (500 ml), and stirred until effervescence ceased, adding further solid sodium hydrogen carbonate in portions as required. The solution was extracted with ether (1 l), and the resulting solution was dried (MgSO_4) and evaporated to an oil. This consisted of two compounds; the required material Rf (H:E, 2:1) 0.60, and a contaminant which proved to be difficult to remove by chromatography, acetoxymethylthiomethyl ether V. The latter was characterized by refractive index measurement $n_D^{20} = 1.4546$ (lit. 1.4540)¹²⁷ and by the following additional spectroscopic data; ν_{max} (CHCl_3) 1740 cm^{-1} , δ_{H} (CDCl_3) 1.8 (3H, s, CH_3CO), 2.0 (3H, s, SCH_3), 4.9 (2H, s, CH_2), δ_{C} (CDCl_3), 15.25 (q \rightarrow s, $\text{CH}_3 \text{CO}$), 20.83 (q \rightarrow s, CH_3S), 68.00 (t \rightarrow s, CH_2), 170.4 (s, CO). Accordingly the method was adapted as follows.

Final procedure. Following addition of the solid sodium hydrogen carbonate, sodium hydroxide (40 g, 1 mol) and ether (1 l) were added and the whole mixture stirred overnight to remove the acetoxymethylthiomethyl ether by hydrolysis. The diethyl ether layer was decanted and the aqueous phase was extracted with more ether (1 l). The combined ethereal extracts were dried and concentrated to a colourless oil which comprised two components by t.l.c. Rf (H:E, 2:1) 0.2 & 0.6. Flash chromatography (500 ml SiO_2 eluted with H:E, 10 : 1) gave essentially pure title compound (32.1 g, 46 %) Rf 0.6, b.p. $126-128^\circ \text{C}$ 760 mmHg, δ_{H} (CDCl_3) 1.26 (9H, s, Bu^t), 2.19 (3H, s, CH_3), 4.51 (2H, s, CH_2) Found: C, 53.3; H, 10.9. $\text{C}_6\text{H}_{14}\text{OS}$ requires C, 53.7; H, 10.4 %.

The material of R_f 0.2 isolated from the flash chromatography stage of the above preparation was distilled under reduced pressure to give pure methylthiomethanol.VI. b.p. $41^\circ\text{C}/13\text{ mmHg}$, $149-51\text{ C} / 1\text{ bar}$. $n_D^{22} = 1.4928$, ν_{max} : 3360, 2920, 1435, 1300, 1020, 990 cm^{-1} , δ_{H} (D_6DMSO) 2.12 (3H, s, CH_3), 4.56 (2H, J= 7.5 Hz, CH_2), 5.62 (1H, t, J= 7.5 Hz, OH), δ_{C} (CDCl_3), 13.5 (q \rightarrow s, CH_3), 67.5 (t \rightarrow s, CH_2), m/z (NH_3 C.I. 200°C), 108 (46 %, unknown), 78 (M^+ , 42), 61 ($\text{CH}_3\text{SCH}_2^+$, 100 %). Found: C, 30.8; H, 7.7; $\text{C}_2\text{H}_6\text{OS}$ requires: C, 30.8; H, 7.7 % .

t-Butylchloromethyl ether (BumCl).II.

The compound is unstable to water and traces of acid, and it was prepared to requirements. t-Butoxymethyl thiomethyl ether (1.5 g, 11 mmol) was dissolved in dichloromethane (50 ml) and sulphuryl chloride (2g, excess) in dichloromethane (10 ml) was added slowly dropwise. The solution was gently swirled over 10 min, occasionally venting the evolved gas es. Evaporation over a cool (15°C) water bath gave essentially pure title compound as a pale yellow oil which was redissolved in a little dichloromethane before use (ca. 90 % due to slight volatility); δ_{H} (CDCl_3) 1.26 (9H, s, $(\text{CH}_3)_3$), 5.55 (2H, s, CH_2). (lit. δ_{H} (CCl_4) 1.25, 5.60)⁴⁷.

t-Butoxymethylimidazole.III.

A solution of t-butylchloromethyl ether (excess) in carbon tetrachloride (50 ml) was added to imidazole (13.6g, 200 mmol) in acetonitrile (200 ml), and the mixture was heated under reflux during 6h. Evaporation of the solvent and excess reagent gave an oily residue which was dissolved in dichloromethane (200 ml), washed with water (5x100 ml) and dried (Na_2SO_4). Following evaporation of the solvent, the residue was distilled bulb-to-bulb using a Kugelröhr apparatus ($50-60^\circ\text{C}$;

0.01 mmHg) to give the title compound as a clear oil (9.7 g, 31%).

m/z 155 (MH⁺) 154 (M⁺):⁴⁵

N[∞]-Benzyloxycarbonylhistidine methyl ester. VII.

This compound was prepared by the optimized though still laborious procedure of Rathbone⁵³ via the bis-benzyloxycarbonyl derivative. Histidine methyl ester dihydrochloride (100 g, 410 mmol) was suspended in chloroform (200 ml) and triethylamine (57 ml, 410 mmol) was added with cooling. Benzylchloroformate (120 ml, 840 mmol) and more triethylamine (115 ml, 825 mmol) were added in alternate small portions, keeping the halide in slight excess. The mixture was stirred at 0° C during 10 min, more chloroform was added to give a homogeneous solution which was stirred for a further 40 min. The solution was diluted with chloroform (1 l) and washed with water (4 l), dried, and the residue after removal of the solvent taken up in a minimum of methanol. This solution (of the bis-Z compound) was treated with ammonia (0.880; 200 ml) over 30 min at R.T. The solution was extracted with dichloromethane (2 l) which was in turn extracted with HCl (1M; 4.5 l). The aqueous phase was basified with sodium carbonate and extracted with dichloromethane. The latter organic phase was dried (Na₂SO₄) and evaporated to a green oil. Trituration with petrol (30-40°) gave the required compound (56 g) as a white solid. The analytical data were consistent with previous samples prepared in this laboratory.⁵³

N[∞]-Benzyloxycarbonyl-N^τ-t-butoxycarbonyl histidine methyl ester. VIII.

N[∞]-Benzyloxycarbonyl histidine methyl ester (60.66 g, 0.20 mol) was dissolved in methanol (150 ml) and the solution was cooled to -5° C. A solution of di-t-butyl dicarbonate (45.83 g, 0.21 mol) in methanol (80

ml) was added dropwise over 40 min. to the vigorously stirred solution. After 1h. at 0°C the mixture was allowed to attain RT overnight. The solvent was removed and replaced by dichloromethane (600 ml) washed with water (3x200 ml) and citric acid (3x200 ml) and dried (Na₂SO₄). Evaporation of the solvent gave the title compound as a pale yellow syrup (75.69 g, 94%) R_F (E4) 0.7 (+ other material x 10%), (α)_D¹⁸ = +20.4° (c=2.11, CCl₄), δ_H(CDCl₃, 200 MHz) 1.59 (9H, s, OC(CH₃)₃), 3.01-3.21 (2H, m, βCH₂), 3.72 (3H, s, OCH₃), 4.60-4.69 (1H, m, αCH), 5.11 (2H, s, PhCH₂), 6.17 (1H, d, NH), 7.13 (1H, s, Im 4), 7.33 (5H, m, Ph), 7.95 (1H, s, Im 2), m/z 404 (2, MH⁺), 347 (16) 304 (26) 57 (100%)

N^α-Benzyloxycarbonyl-N^π-t-butoxymethylhistidine methyl ester. X.

A solution of t-butylchloromethyl ether (excess) in carbon tetrachloride was added dropwise to a stirred solution of N^α-benzyloxycarbonyl-N^π-t-butoxycarbonyl histidine methyl ester (60.51g, 0.15 mol) in dichloromethane (200 ml) maintained at 4°C under an atmosphere of argon. The addition was stopped when the starting material had been consumed (t.l.c.; 3-5 h.). The solution was then diluted with dichloromethane (400 ml) and extracted with citric acid (10%; 6x 300 ml), the pH of the combined acid extracts was adjusted to 6 by addition of Na₂CO₃, and the resulting aqueous solution was extracted with diethyl ether (6x300 ml). The combined ethereal extracts were dried (Na₂SO₄), filtered, and evaporated to give the title compound as a hygroscopic oil (38.7 g, 66%) which could not be solidified. R_F (E4) 0.52, (α)_D¹⁸ = -23.1° (c = 1.06 methanol), δ_H (CDCl₃), 1.25 and 1.33 (9H, 2xs, OC(CH₃)₃), 3.07-3.25 (2H, m, βCH₂), 3.75 (3H, s, OCH₃), 4.61-9 (1H, m, αCH), 5.07 (2H, s, PhCH₂), 5.21 and 5.29 (2H, 2xs, NCH₂O), 5.70 (1H, d, NH), 6.82 (1H, s, Im 4), 7.33 (5H, m, Ph), 7.51 (1H, s, Im 2). m/z 390

(MH⁺, 11%), 389 (M⁺, 12), 330 (12) 238 (27), 91 (100).

N^α-Benzyloxycarbonyl-N^π-t-butoxymethylhistidine. XI.

The preceding methyl ester (46.73 g, 0.12 mol) was dissolved in methanol (100 ml) and the solution was placed in a vessel equipped with a pH monitor. Sodium hydroxide (1M; 120 ml) was added dropwise with stirring such that the "pH" never exceeded a value of 11.8. After 40 min at RT hydrolysis was complete and the "pH" of the solution was adjusted to 6 by addition of 1M HCl. Following evaporation of the methanol, sodium chloride (30 g) was added to the aqueous solution which was then extracted with chloroform (6x200 ml). The combined organic extracts (during some preparations the product separated at this time as a solid, which was collected by filtration) were dried over Na₂SO₄, filtered, and concentrated. The acid separated as a white solid, which was collected by filtration. This material was dissolved in a large volume of hot methanol and precipitated by addition of a few drops of water. After standing overnight at -20°C, the voluminous white solid was filtered, washed with ether and dried in vacuo to give the title compound (37.5 g, 83%). Rf (A3) 0.43, m.p. 186-7°C (α)_D¹⁸ = -10.7° (c=1, acetic acid).

Further analytical data is given along with the alternative method of preparation detailed below.

N^α-Benzyloxycarbonyl-N^τ-triphenylmethylhistidine methyl ester. XIII.

N^α-Benzyloxycarbonylhistidine methyl ester (5.05 g, 16.7 mmol) was suspended in a solution of triphenylmethyl chloride (5.10 g, 18.3 mmol) in dry benzene (50 ml). Triethylamine (approx 3 ml) was added, and the solution was heated under refluxing conditions during 2 h. After cooling the precipitated triethylammonium chloride was removed by filtration.

Removal of the bulk of the solvent, followed by addition of a mixture of ether and hexane and further evaporation gave a crystalline solid which was washed liberally with dry ether and dried in vacuum to give the required compound (9.1 g, 71 %) R_f (E3) 0.80, m.p. 135-137^oC (lit. 58-63^oC), ν_{max} 3430, 1760-1700 cm^{-1} , δ_H (CDCl₃) 3.05 (2H, bd, β CH₂), 3.63 (3H, s, OCH₃), 4.61 (1H, m, α CH), 5.12 (2H, s, CO₂CH₂), 6.36 (1H, bd, NH), 6.56 (1H, s, Im5), 7.0-4 (21H, m, Ar & Im2), m/z (+ ve Ar FAB) 546 (MH⁺ 2 %), 243 (100), 165 (27) (α)_D²⁰ + 17.2 (c = 0.5 CHCl₃).

N ^{α} -Benzyloxycarbonyl-N ^{π} -t- butoxymethyl-N ^{τ} - triphenylmethylhistidinium chloride methyl ester. XIV.

N ^{α} -Benzyloxycarbonyl-N ^{τ} -triphenylmethylhistidine methyl ester (5.45 g, 10 mmol) was dissolved in dichloromethane (20 ml) and a solution of t-butoxymethyl chloride in the same solvent (10 ml), prepared from 2 g of BumSMe, was added slowly. The solution was stirred at R.T. during 12 h. After this time addition of a little (20 ml) ether resulted in the formation of a sticky yellow precipitate, which consisted of approximately 20 % of the required compound and 80 % of the starting material as hydrochloride. This solid was discarded. Addition of a large excess of ether to the remaining solution gave a white crystalline solid which was recrystallized from dichloromethane / light petroleum to give the title compound (190 mg, 3 %). However a repeat reaction using a total of 30 ml CH₂Cl₂ and 30 ml ether gave an acceptable sample of the crude imidazolium salt (5.25 g, 79 %) which only required a single further crystallization to analytical purity. R_f (E4) 0.25, m.p. 132-133^oC, (α)_D²⁸ = -14.9^o (c = 1.03, CHCl₃), δ_H (CDCl₃) 1.29 (9H, s, (CH₃)₃), 3.28 (2H, m, β CH₂), 3.80 (3H, s, OCH₃), 4.66 (1H, m, α CH), 5.09 (2H, s, CO₂CH₂), 5.58 (2H, bs, NCH₂), 5.79 (1H, d, NH), 7.04 (2H, m, Ar), 7.16 (1H, s, Im5), 7.3

(18H, m, Ar), 9.08 (1H, s, Im2), m/z 632 (M^+ 100 %), 390 (20), 243 (26), Found C, 69.7; H, 6.4; N, 6.1; Cl, 5.6. $C_{39}H_{42}N_3O_5Cl$ requires C, 70.1; H, 6.3; N, 6.3; Cl, 5.3 %.

N^{α} -Benzyloxycarbonyl- N^{π} -t-butoxymethylhistidine.XI.

N^{α} -Benzyloxycarbonyl- N^{π} -t-butoxymethyl- N^{τ} -triphenylmethylhistidinium chloride methyl ester (330 mg, 0.5 mmol) and sodium carbonate (0.21 g, 2 mmol) were dissolved in 50 % aqueous methanol (20 ml). The solution was heated under reflux for 2 h, cooled, and the methanol removed by rotary evaporation. The remaining aqueous solution was quickly adjusted to pH5 with 5M HCl, and extracted with ethyl acetate (4x50 ml). The combined extracts were washed with water, dried ($MgSO_4$) and evaporated to give the title compound as a white solid (155 mg, 84 %) R_F (R1) 0.35, m.p. 186-7° C, $(\alpha)_D^{22} = -6.8^{\circ}$ ($c = 1.405$, acetic acid), δ_H (DMSO) 1.19 (9H, s, $(CH_3)_3$), 2.72-3.28 (2H, m, βCH_2), 4.33 (1H, m, αCH), 5.00 (2H, s, $PhCH_2$), 5.32 (2H, s, NCH_2), 6.74 (1H, s, Im4), 7.33 (5H, s, Ph), 7.61 (1H, d, NH), 7.75 (1H, s, Im2). m/z 375 (M^+), 376 (MH^+).

N^{π} -t-Butoxymethylhistidine.I.

N^{α} -Benzyloxycarbonyl- N^{π} -t-butoxymethylhistidine (15.02 g, 40 mmol) was dissolved in glacial acetic acid (120 ml) containing 10% palladium on charcoal (2.0 g), and a stream of hydrogen was passed through the reaction vessel while the mixture was stirred. After 3h. the reaction was complete (t.l.c.). The catalyst was removed by filtration and the solvent was evaporated to give a white foam. This was crystallized from water-acetone, filtered, and washed with dry acetone. After drying in vacuo over P_2O_5 the title compound was obtained as white crystals (8.75 g, 91%). R_F (Cl) 0.59, m.p. 212-9° C (dec), $(\alpha)_D^{18} = 3.7^{\circ}$ ($c=1$,

AcOH), δ_{H} (D_2O , 80 MHz)^{*} 1.30 (9H, s, $\text{OC}(\text{CH}_3)_3$), 3.00-3.54 (2H, m, βCH_2), 4.01 (1H, q, αCH), 5.45 (2H, s, $-\text{CH}_2\text{O}$), 6.98 (1H, s, Im4), 7.85 (1H, s, Im2). *Canton Hospital. Milan.

N^∞ -Triphenylmethyl- N^π -triphenylmethylhistidine methyl ester. XV.

The compound is mentioned in the literature without specific preparative details or spectroscopic data.⁵⁴ Histidine methyl ester dihydrochloride (12.1 g, 50 mmol) was suspended in chloroform (100 ml) and solubilized by addition of excess triethylamine (27.9 g, 200 mmol). A solution of trityl chloride (27.9 g, 100 mmol) in chloroform (50 ml) was added and the reaction heated under reflux during 12 h. Upon cooling, the solution was washed with a large quantity of water to remove salts and evaporated to an oil. The oil was washed with ether to remove excess alkylating agent and purified by flash chromatography in ethyl acetate. Appropriate fractions were pooled and evaporated, and the resulting oil was crystallized from methanol water. Trituration with water and drying in vacuo gave the title compound (17.1 g, 53 %). R_{F} (EtOAc) 0.50, m.p. 94-6^o C, $(\alpha)_{\text{D}}^{20} = + 12.4^{\circ}$ ($c = 2.845$, methanol), δ_{H} (CDCl_3) 2.75 (1H, d, NH), 2.91 (2H, oc, βCH_2), 3.08 (3H, s, OCH_3), 6.68 (1H, s, Im5), 7.30 (24H, m, Ar), 7.38 (1H, d, Im2), 7.45 (6H, m, Ar), m/z (FD) 676 (M Na^+), 654 (MH^+). (+ve Ar FAB) 654 ($\text{MH}^+ 1\%$), . 243 (100), 165 (24), Found C, 82.9; H, 6.1; N, 6.1; $\text{C}_{45}\text{H}_{39}\text{N}_3\text{O}_2$ requires C, 82.7; H, 6.0; N, 6.4%

N^∞ -Triphenylmethyl- N^π -t-butoxymethyl- N^π -triphenylmethylhistidinium chloride methyl ester. XVI.

N^∞ -Triphenylmethyl- N^π -triphenylmethylhistidine methyl ester (1.31 g, 2 mmol) and t-butoxymethyl chloride (prepared from 2.2 mmol of BumSMe), were dissolved in 10 ml and 5 ml respectively of dry ether. The solutions

were mixed and allowed to react for 2 h. After this time the bulk of the material crystallized out; and on the assumption that it was the required material it was washed with excess dry ether and dried under vacuum. Subsequent examination by t.l.c. and n.m.r. demonstrated the compound was the hydrochloride derivative of the starting material, with only a trace of the required material. The presence of the title compound was indicated by mass spectrometry; m/z 740 (M^+ , 1%), 498 (7), 243 (100). The reaction was not pursued further.

Mesitylmethoxyacetic acid. XXI.

Sodium hydride (50% dispersion in oil, excess), was added to a solution of mesitylmethanol (5.0 g, 33 mmol) in dry benzene (100 ml). The mixture was stirred and heated under reflux during 2h. Chloroacetic acid (3.1 g, 33 mmol) was added and the mixture heated for a further 5h. After cooling, the mixture was added to water (100 ml). The aqueous phase was separated, the benzene layer was extracted with sodium hydroxide (2N; 2x50 ml) and the aqueous solutions were combined, extracted with ether and acidified. Extraction with chloroform gave, after recrystallisation from methanol/60-80° petrol, the required compound (3.71 g, 49%). m.p. 112-5°C Found: C, 68.8; H, 7.7; Calc. for $C_{12}H_{16}O_3$: C, 69.2; H, 7.7%.

Mesitylmethoxymethylimidazole. XXIII.

The above acid (250 mg, 1.2 mmol) was dissolved in dry benzene (20 ml) and dry lithium chloride (51 mg, 1.2 mmol), lead tetraacetate (540 mg, 1.2 mmol) and imidazole (245 mg, 3.6 mmol) were added. The mixture was flushed with dry nitrogen and then heated under reflux during 45 min. The solvent was evaporated and the residue was distributed between ether (20 ml) and sodium hydroxide solution (1N; 20 ml). The aqueous layer

was separated and extracted with ether. The ethereal solutions combined and concentrated, and flash chromatography (3% MeOH/CHCl₃) gave the title compound (40 mg, 14%). This was recrystallised from light petroleum at low temperature to give material of m.p. 63-4^o C, Found C, 73.2; H, 7.7; N, 12.2; C₁₄H₁₈N₂O requires C, 73.0; H, 7.3; N, 12.2%, m/z 231 (MH⁺).

Mesitylmethoxymethylthiomethane. XXII.

Mesityl methanol (20 g, 133 mmol), prepared in three steps from mesitylene, was dissolved in a mixture of dimethyl sulphoxide (200 ml) and acetic anhydride (200 ml). The mixture was allowed to stand for 3 days at R.T. and was then poured carefully into saturated sodium carbonate solution (1 l). Solid sodium carbonate was added until effervescence ceased, and then in slight excess. The mixture was stirred during 2 h, and extracted into ether (2 l); evaporation of the solvent gave the crude material (60.8 g). An aliquot (3.0 g) was purified by flash chromatography in hexane ether (7:1) to give, after pooling and evaporation of appropriate fractions, the title compound as a mobile liquid (0.73 g; 53%), R_f 0.40 (molyb.), δ_H (CDCl₃) 2.23 (3H, s, SCH₃), 2.28 (3H, s, p-CH₃), 2.40 (6H, s, O-CH₃), 4.62 (2H, s, OCH₂S), 4.71 (2H, s, ArCH₂O), 6.87 (2H, s, m-ArH), Found C, 68.5; H, 8.9; C₁₂H₁₈OS requires C, 68.6; H, 8.57%. (Subsequent work in this laboratory; b.p. 112^o C, 2mm Hg).

Mesitylmethoxymethyl chloride (Tom Cl). XIX.

Mesitylmethoxymethylthiomethyl ether (2.1 g, 10 mmol), was dissolved in dry dichloromethane and cooled over an ice bath. Sulphuryl chloride (1.21 ml, 15 mmol) diluted with dichloromethane (50 ml) was added slowly under nitrogen over a few minutes. The reaction appears to be essentially instantaneous as evidenced by the immediate colour change (yellow methyl

chlorosulphide). The use of t.l.c. is not appropriate with this compound, but the reaction appeared quantitative by low resolution n.m.r. (2.03 g, 90 %). m.p. approx. 30°C. (lit.⁵⁶ 35-7°C) $\delta_{\text{H}}(\text{CDCl}_3)$ 2.30 (3H, s, p-CH₃), 2.40 (6H, s, o-CH₃), 4.85 (2H, s, ArCH₂O), 5.60 (2H, s, OCH₂Cl), 6.90 (2H, s, ArH).

N^α-Benzyloxycarbonyl-N^π-mesitylmethoxymethyl-N^τ-triphenylmethylhistidinium chloride methyl ester. XXV.

Freshly prepared mesitylmethoxymethyl chloride (11.9 g, 60 mmol) was dissolved in ether (70 ml) and the solution was added dropwise over 3h. to a stirred solution of N^α-benzyloxycarbonyl-N^τ-triphenylmethylhistidine methyl ester (27.3 g, 50 mmol) in ether (270 ml). The reaction mixture was stirred at room temperature during 18h. The white precipitate was removed by filtration and was washed with ether to give the title compound (30.5 g, 82%). On other occasions the product failed to crystallize from the reaction mixture and this author and others were obliged to proceed with impure imidazolium salt. M.p. 110-118°C, $(\alpha)_{\text{D}}^{20} -9.5^{\circ}$ (c=1, CHCl₃). $\delta_{\text{H}}(\text{CDCl}_3)$ 2.20 (6H, s, o-CH₃), 2.25 (3H, s, p-CH₃), 3.25 (2H, bm, β CH₂), 3.70 (3H, s, CO₂CH₃), 4.60 (3H, m, αCH & ArCH₂O-), 5.00 (2H, s, PhCH₂), 5.70 (2H, b m, NCH₂O-), 6.10 (1H, b d, NH), 6.80 (2H, s, Ar), 7.05 (1H, s, Im4), 7.20 (20H, m, Ar), 9.50 (1H, b s, Im2). m/z 708 (M⁺) Found C, 72.35; H, 6.2; N, 5.6.

C₄₅H₄₆N₃O₅Cl requires C, 72.6; H, 6.2; N, 5.65%.

N^α-Benzyloxycarbonyl-N^π-mesitylmethoxymethyl histidine. LXI.

The preparation and characterization of this compound is discussed in chapter 7

N^π-Mesitylmethoxymethylhistidine. XXVII.

N^α-Benzyloxycarbonyl-N^π-mesitylmethoxymethylhistidine (152 mg, 0.20 mmol) was dissolved in aqueous acetic acid (80%; 15 ml) and 10% palladium on charcoal (15 mg) was added. Hydrogen gas was bubbled into the stirred reaction mixture for 20 min., after which t.l.c. indicated that reaction was complete. The catalyst was removed by filtration and the solvent was evaporated, yielding a white foam. This was crystallized from hot water, yielding the hydrated amino acid as white crystals (75 mg, 70%), m.p. 193-205° (rapid heating), (α)_D²⁰ -8.75° (c=1, MeOH), m/z 318 (MH⁺), Found: C, 63.5; H, 7.6; N, 12.5. C₁₇H₂₃N₃·0.3H₂O requires C, 63.3; H, 7.3; N13.0%

N^α-Triphenylmethyl-N^π-mesityloxymethyl-N^τ-triphenylmethylhistidium chloride methyl ester. XXVIII.

N^α-Triphenylmethyl-N^τ-triphenylmethylhistidine methyl ester (3.25 g, 5 mmol) was dissolved in dry ether (20 ml), and a solution of Tom chloride (1.2 g, 6 mmol) in ether (5 ml) was slowly added with stirring. After 15 min. a sticky solid began to separate, and to avoid this complication 20 ml of dichloromethane was added. The homogeneous solution was allowed to stand a further 12 h. at R.T. Addition of dry ether (100 ml) precipitated a solid (2.6 g) which was separated by decantation and washed several times with fresh ether. This material was shown to be of around 50 % purity by n.m.r. (equiv. yield 35 %). δ_H (CDCl₃, abstracted) 2.20 (6H, s, o-CH₃), 2.28 (3H, s, p-CH₃), 3.17 (2H, m, β CH₂), 3.27 (3H, s, OCH₃), 3.70 (1H, m, α CH), 4.63 (2H, d of d, ArCH₂), 5.68 (2H, m, NCH₂), 6.85 (2H, s, m-ArH on Tom), 6.91 (1H, s, Im5), 7.30 (30H, b.m, Ph), 8.10 (1 H, s, Im2). Separation from the hydrochloride of the starting material was not practicable, and it was carried to the next stage without further

characterization. On other occasions the title compound crystallized out separately, and full analytical details are given in chapter 7.

N^α-Triphenylmethyl-N^π-mesitylmethoxymethylhistidine methyl ester. XXXIX.

A sample of the imidazolium chloride described above, of approximately 50 % purity (850 mg) was dissolved in methanol (20 ml). A solution of sodium carbonate (0.53 g, excess) in water (20 ml) was added and the mixture was heated under reflux during 1 h. The more volatile solvent was removed by rotary evaporation, and the resulting solution was acidified to pH4 with hydrochloric acid. The resulting aqueous suspension was extracted with several 50 ml portions of ethyl acetate, and the combined organic extracts were washed with water, dried and evaporated to an oil. Flash chromatography in 4 % MeOH / CHCl₃ gave a material R_f 0.35 (the methyl ester). Pooling of appropriate fractions and evaporation gave a crystalline solid (125 mg, 38 %) mp. 67-9^o C, (α)_D¹⁸ = + 64.5^o (C = 1.03, EtOAc). δ_H (CDCl₃) 2.20 (6H, s, o-CH₃), 2.28 (3H, s, p-CH₃), 2.76 (1H, d, NH) 3.06 (3H, s, OCH₃), 3.08 (2H, q of d, β CH₂), 3.54 (1H, m, α CH), 4.38 (2H, s, OCH₂Ar), 5.33 (2H, s, NCH₂), 6.86 (2H, s, m-Ar), 6.90 (1H, s, Im4), 7.2, 7.4 (15H, m, Ph), 7.58 (1H, s, Im2) m/z 574 (MH⁺ 17 %), 243 (100), 133 (74).

Phthaloylhistidine. XXXI.

Histidine hydrochloride monohydrate (14.8 g, 100 mmol) was ground to a fine powder in a mortar and suspended in toluene (200 ml). Triethylamine (12.1 g, 120 mmol) and phthalic anhydride (14.8 g, 100 mmol) were added, and the suspension was heated under reflux during 4 h. breaking up any lumps which form. Removal of the toluene by rotary evaporation and crystallization from boiling water gave the crude product. Recrystalliz-

ation from water gave the title compound as translucent granules which were dried under vacuum at 60°C (7.69 g, 27 %), m.p. $245-6^{\circ}\text{C}$ (sublimes) $(\infty)_{\text{D}}^{20} = -108.5^{\circ}$ ($c = 1.9$, 5M HCl), δ_{H} (D_2O 60 MHz) 3.6-7 (2H, d, β CH_2), 5.1-2 (1H, d, α CH), 7.3 (1H, s, Im4), 7.9 (4H, s, Ar), 8.6 (1H, s, Im2), m/z (+ve Ar FAB), 286 (MH^+ 100 %), 240 (26), 95 (10). Found C, 59.0; H, 3.8; N, 14.6; $\text{C}_{14}\text{H}_{11}\text{N}_3\text{O}_4$ requires C, 59.0; H, 3.9; N, 14.7 %.

N^{∞} -Phthaloyl- N^{τ} -triphenylmethylhistidine. XXXII.

Phthaloylhistidine (2.85 g, 10 mmol) and triethylamine (1.21 g, 12 mmol) were dissolved in warm formamide (80 ml). A solution of trityl chloride (3.34 g, 12 mmol) in benzene (20 ml) was then added, and the solution heated under reflux (approx. 80°) with efficient stirring (layers only partially miscible) during 20 h. The mixture was cooled, and the benzene was removed by rotary evaporation. The formamide solution was washed with ether (50 ml), diluted with water (100 ml) and taken to pH6 with dilute hydrochloric acid. Extraction of the product into several 50 ml portions of dichloromethane, drying and evaporation gave the crude material as a brown oil. Flash chromatography in E4 gave the product as an oil, which upon trituration with ether gave a white solid (2.25 g, 43 %), m.p. $142-5^{\circ}\text{C}$, $(\infty)_{\text{D}}^{20} = -46.1^{\circ}$ ($c = 4.62$, CHCl_3), δ_{H} (CDCl_3) 3.38, 3.87 (2H, d of q, β CH_2), 5.23 (1H, m, α CH), 6.49 (1H, s, Im5), 6.97-7.23 (15 H, m, Ar), 7.58 (1H, s, Im2), 7.70, 7.78 (2H, 2H, m, pth), m/z 528 (MH^+ , 2 %), 484 (1), 243 (100) 165 (28), Found C, 75.4; H, 5.0; N, 7.6, $\text{C}_{33}\text{H}_{25}\text{N}_3\text{O}_4$ requires C, 75.1; H, 4.7; N, 8.0 %.

N^{∞} -Phthaloyl- N^{π} -benzyloxymethylhistidine. XXXIV.

N^{∞} -Phthaloyl- N^{τ} -triphenylmethylhistidine (2.11 g, 4 mmol) was dissolved

in dry dichloromethane (15 ml), followed by benzyloxymethyl chloride (0.75 g, 4.8 mmol; 670 μ l). T.l.c was uninformative, showing several acidic compounds (P2, Mary's spray), so the solution was allowed to stand at R.T. for 2 days. The solvent was removed by rotary evaporation and replaced by 70 % aqueous acetic acid. Boiling for 15 mins and subsequent cooling precipitated triphenylcarbinol, which was removed by filtration and discarded. The solvent was again removed, and the residue taken up in a minimum of dichloromethane and extracted into saturated sodium hydrogen carbonate solution. Acidification with 5M H_2SO_4 followed by attempted extraction into ethyl acetate resulted in the separation of white crystals. There proved to be nothing in the ethyl acetate extracts, so the solid was washed with ethyl acetate and water, and dried under vacuum to give the title compound (200 mg, 11 %), m.p. 205-8 $^{\circ}$ C, $(\alpha)_D^{20} = -120.2^{\circ}$ (c = 1.22, DMF), δ_{H} (D_6 -DMSO) 3.47 (2H, m, βCH_2), 4.44 (2H, q, αCH_2O), 5.09 (1H, m, αCH), 5.47 (1H, s, NCH_2O), 6.51 (1H, s, Im4), 7.30 (5H, m, Ar), 7.72 (1H, s, Im2), 7.87 (4H, s, pth), m/z (NH_3 DCl), 406 (MH^+ 84 %), 362 (100), 300 (28), 286 (28), 242 (37), Found C, 64.2; H, 4.6; N, 10.0; $C_{22}H_{19}N_3O_5 \cdot \frac{1}{2} H_2O$ requires C, 64.0; H, 4.8; N, 10.2 %.

N^{α} -Benzyloxycarbonyl- N^{π} -t-butoxymethylhistidylphenylalanyl- N^G -nitroarginine benzyl ester. XXXVII.

N^{α} -t-Butoxycarbonylphenylalanyl- N^G -nitroarginine benzyl ester (139 mg, 0.25 mmol) was dissolved in ice cold TFA (2 ml) and stirred. After 0.5 h. the TFA was removed and the residue triturated with ether (10 ml) for a further 1 h. The ether was decanted, the residue dissolved in DMF (1 ml), and the "pH" was adjusted to around 9.5 with triethylamine to give solution Λ . N^{α} -Benzyloxycarbonyl- N^{π} -t-butoxymethylhistidine (94 mg,

25 mmol), HOBT (37 mg, 27 mmol) and DCCI (52 mg, 25 mmol) were dissolved in DMF (1 ml). To this solution, cooled in an ice bath, was added solution A, and the reaction was allowed to warm to RT over 12 h. The precipitate of DCU was filtered off and the filtrate applied directly to a column of Sephadex LH 20 swollen and eluted with DMF. Appropriate fractions were pooled and evaporated to a small volume, whereupon addition of ether gave a precipitate. The ether was decanted and the residue washed with ether and dried under vacuum to give the title compound (180 mg, 89 %). M.p. 110-7^oC. δ_{H} (D_7DMF) 1.21 (9H, s, $(\text{CH}_3)_3$), 1.69, 1.93 (6H, m, Arg CH_2), 3.11 (2H, m, β CH_2 (Phe)), 4.49 (2H, m, α CH s), 4.74 (1H, m, α CH), 5.05 (2H, d, β CH_2), 5.19 (2H, s, CO_2CH_2) 5.39 (2H, s, NCH_2) 6.75 (1H, s, Im4), 7.2-3 (15H, m, Ar), 7.74 (1H, s, Im2). M/z (FD, 21 mA), 814 (MH^+); (22 mA), 836 (MNa^+), 814 (MH^+).

N^{π} -t-Butoxymethylhistidylphenylalanylarginine. XXXVI.

The preceding fully protected tripeptide (150 mg, 18 mmol) was dissolved in 80 % aqueous acetic acid (5 ml) and hydrogenated in the presence of 10 % palladium on carbon (100 mg), during 20 h. After this time the catalyst was removed by filtration through celite and the filtrate was evaporated to a small volume and applied to a column of Sephadex G10, swollen and eluted with 5 % acetic acid. Appropriate fractions were selected on the basis of their u.v. absorption profile, noting the preponderance of materials whose retention factor was higher, pooled and evaporated. Following repeated addition and removal of water by high-vacuum rotary evaporation an attempt was made to freeze dry the material, but with poor results. Grinding under ether gave a solid which was extremely hygroscopic and which could not be made to pass elemental analysis. However it appeared to be the title compound (22 mg, 23 %). δ_{H} (D_2O); 1.11

(9H, s, $(\text{CH}_3)_3$), 1.37 (2H, m, Arg CH_2), 1.53, 1.61 (3H, m, Arg CH_2), 1.76 (9H, s, CH_3CO_2^-), 2.54 (1H, s, Arg δ CH), 2.87 and 3.00 (2H, oct, β CH_2), 3.07 (2H, m, β CH_2), 3.91 (1H, t, α CH), 4.03 (1H, t, α CH), 4.48 (1H, t, α CH on His), 5.32 (2H, s, NCH_2), 6.86 (1H, bs, Im4), 7.17 (5H, m, Ph), 8.05 (1H, s, Im2).

The above material was dissolved in TFA and allowed to stir for 0.5 h. The TFA was removed and the residue triturated with ether to give histidylphenylalanylarginine tristrifluoroacetate which was essentially the same by n.m.r. as the acetate salt from the alternative route. The two materials were concurrent by t.l.c. (cellulose), in F2, a system which removes the counter ion.

CHAPTER 6. Nuclear Overhauser measurements, and methylation/amino-
acid analysis of histidine derivatives.

The experimental details for each compound whose structure was under investigation are divided into three sections:

A). The origin of the sample, together with preparative details where appropriate, and the basic n.m.r. spectrum taken in the same solvent as that in which the nuclear Overhauser enhancement experiments were performed

B). The results of equilibrium n.O.e. measurements performed by the difference method at 300 MHz. Samples were approximately 5 mM solutions in CDCl_3 or $(\text{CD}_3)_2\text{SO}$, and were degassed by passage of a stream of nitrogen or by alternate freezing and pumping. The n.O.e. was generated by pre-irradiation of each of the imidazole protons for 5s. in separate experiments; in order to achieve sufficient selectivity between these and the nearby phenyl resonances it proved necessary to use r.f. field strengths of 5-15 Hz. Under these conditions saturation was not complete, but was sufficient to give readily detectable effects. Acquisition of the perturbed and unperturbed (with irradiation off-resonance) signals were interleaved during the course of the accumulation. Percentage n.O.e.s (quoted in the form "A=") are reported relative to the intensity of the same line in the unperturbed spectrum.

C). The details of conversion into β -methylhistidines and subsequent examination using an amino-acid analyser. Using only the short column of a Jeol JLC 5AH instrument, conditions were optimised (45°C ; pH 4.28; 0.35 M sodium citrate buffer) for the separation of "1-methylhistidine", "3-methylhistidine", and histidine, and their determination when mutually admixed. The following colour values were established for the standards:-

1-Methylhistidine	8.03	$\times 10^{-3}$	(arb. units).
Histidine	11.39	$\times 10^{-3}$	
3-Methylhistidine	10.79	$\times 10^{-3}$	

The histidine derivative whose orientation was under investigation (ca. 10 mg) was dissolved in methyl iodide (5 ml). In cases of insufficient solubility, enough DMF to dissolve the derivative was first added. After 24 h. at RT removal of methyl iodide and DMF (if any) gave a residue which was heated with "constant boiling" hydrochloric acid under reflux for 24 h. In cases where difficulties in methylation were experienced the compound (10 mg) was treated with trimethyloxonium fluoroborate (200 mg) in dry dichloromethane (5 ml) for 24 h at RT. If methoxyethoxymethyl groups were present the residue was gently warmed for 5 h with anhydrous zinc bromide (5 mol. equiv.) in dichloromethane (10 ml) before the treatment with acid. The hydrochloric acid treatment alone sufficed to remove all blocking groups in the other cases. The hydrochloric acid was evaporated off and the residue was redissolved to give a solution in 0.01 M HCl for amino acid analysis.

Two examples of cross-ring coupling constants are included in the data, and were measured at 500 MHz

All the compounds discussed were obtained in a chromatographically homogeneous state.

N^{α} -t-Butoxycarbonyl- N^{π} -benzyloxymethylhistidine. XL

Preparation. Ordinarily the commercially available material as supplied by Cambridge Research Biochemicals was used for synthetic work, however for these investigations the particular sample (the monohydrate) prepared in this laboratory for X-ray crystallography was used.

δ_H (CDCl₃); 1.44 (9H, s, (CH₃)₃), 3.28 (2H, d, β CH₂), 4.43 (1H, d, α CH), 4.48 (2H, s, PhCH₂), 5.41 (2H, m, NCH₂), 5.73 (1H, d, NH), 6.97 (1H, s, Im4), 7.30 (5H, m, Ph), 7.94 (1H, s, Im2).

n.o.e. measurements. The sample was degassed by passage of nitrogen.

The following effects were observed; Irr 7.94 gave $A=0.90$ at 5.41, $A=0.5$ at 4.48. Irr 7.30 and 6.97 gave $A=2.00$ at 4.48. Irr 6.97 gave no A.

Methylation and analysis. Methylation was performed using neat methyl iodide. The 3-methylhistidine peak was eluted after 57 min. Peak areas; NH_3 ; 0.1528, 1-methylhistidine; nil, histidine; 0.8713 (76 nmol ml^{-1}), 3-methylhistidine; 1.1727 (109 nmol ml^{-1}). Extent of reaction 59%, Isomeric excess 100%.

N^α -t-Butoxycarbonyl- N^π -benzyloxymethylhistidine methyl ester. XL I

Preparation. The compound was prepared in good yield in this laboratory via bis-t-butoxycarbonylhistidine whose structure is also thus established. δ_{H} (CDCl_3); 1.42 (9H, s, $(\text{CH}_3)_3$), 3.16 (2H, q of d, $\beta \text{ CH}_2$), 3.73 (3H, s, OCH_3), 4.45 (2H, s, PhCH_2), 4.58 (1H, m, $\alpha \text{ CH}$), 5.30 (2H, q, NCH_2), 6.88 (1H, s, Im4), 7.32 (5H, m, Ph), 7.48 (1H, s, Im2).

n.O.e. measurements. The sample was degassed by passage of nitrogen. The following effects were observed; Irr 7.48 (and some 7.32) gave $A=1.90$ at 5.30 and $A=0.60$ at 4.45. Irr 6.88 gave $A=0.50$ at 4.45, and $A=0.60$ at 3.16.

Methylation and analysis. Methylation was performed using neat methyl iodide. The 3-methylhistidine peak was eluted after 58 min. Peak areas; NH_3 ; 0.1415, 1-methylhistidine; 0.0275 (3.4 nmol ml^{-1}), histidine; nil, 3-methylhistidine; 1.8970 (176 nmol ml^{-1}). Extent of reaction 100%. Isomeric excess 98%.

N^π -Methylhistidine. XXXVIII

Preparation. The compound was obtained from the Sigma Chemical company described as "1-methyl-L-histidine", lot number 79C-0355. δ_{H} (D_2O);

3.02 (2H, q of d, β CH₂), 3.46 (3H, s, NCH₃), 3.70 (1H, q, α CH), 6.75 (1H, s, Im4), 7.52 (1H, s, Im2).

n.O.e. measurement. The sample was degassed by alternate freezing and pumping. The following effects were observed; Irr 7.52 gave A= 0.3 at 3.46. Irr 6.75 gave A= 0.8 at 3.02.

Methylation and analysis. This compound was used as a standard, prepared at 159.6 nmol ml⁻¹, for the evaluation of the colour yield in the reaction with ninhydrin. The 1-methylhistidine peak was eluted after 45 min. Peak areas; NH₃; 0.1448, 1-methylhistidine; 1.2810, histidine (as an auxiliary standard); 1.5410, 3-methylhistidine; nil (no cross-contamination). $k_{1-me} = 8.03 \cdot 10^{-3}$.

N^T-Methylhistidine. XXXIX

Preparation. The compound was obtained from the Sigma Chemical company described as "3-methyl-L-histidine", lot number 88C- 0040. δ_H (D₂O); 2.91 (2H, q of d, β CH₂), 3.47 (3H, s, NCH₃), 3.75 (1H, q, α CH), 6.77 (1H, s, Im5), 7.38 (1H, s, Im2)

n.O.e. measurement. The sample was degassed by alternate freezing and pumping. The following effects were observed; Irr 7.38 gave A= 1.20 at 3.47. Irr 6.77 gave A= 3.00 at 3.47 and A= 1.1 at 2.91.

Methylation and analysis. This compound was used as a standard, prepared at 136.2 nmol ml⁻¹, for the evaluation of the colour yield in the reaction with ninhydrin. The 3-methylhistidine peak was eluted after 59 min. Peak areas; NH₃; 0.1448, 1-methylhistidine; nil (no cross-contamination), histidine (as an auxiliary standard); 1.5410, 3-methylhistidine; 1.4699. $k_{3-me} = 10.79 \cdot 10^{-3}$.

N[∞]-Benzyloxycarbonyl-N[∞]-triphenylmethylhistidine methyl ester. XIII

Preparation. Details of the preparation of this compound are described in chapter 1. Nuclear Overhauser enhancement measurements are inappropriate for a compound of this structure.

Methylation and analysis. Methylation was performed using neat methyl iodide. The 1-methylhistidine peak was eluted after 46 min. Peak areas; NH₃; 0.1255, 1-methylhistidine; 0.4745 (42 nmol ml⁻¹), histidine; 1.2520 (66 nmol ml⁻¹), 3-methylhistidine; nil. Extent of reaction 39%. Isomeric excess 100%.

N[∞]-Benzyloxycarbonyl-N[∞]-phenacylhistidine methyl ester. LI

Preparation. The hydrobromide salt (prepared by Ramage)¹²⁹ (251 mg, 0.5 nmol) was suspended in ethyl acetate (20 ml) and washed with saturated sodium bicarbonate solution (20 ml) until all the solid had dissolved. The organic layer was washed with water (20 ml), dried (MgSO₄) and evaporated to give a colourless oil which could not be solidified (195 mg, 92%). δ_H (CDCl₃); 3.06 (2H, d, β CH₂), 3.73 (3H, s, OCH₃), 4.55 (1H, q, ∞CH), 5.03 (2H, m, PhCH₂), 5.35 (2H, q, NCH₂). 5.61 (1H, d, NH), 6.88 (1H, s, Im4), 7.33 (5H, m, Ar), 7.43 (1H, s, Im2), 7.54 (2H, m, Ar), 7.68 (1H, m, Ar), 7.98 (2H, m, Ar).

n.o.e measurement. The sample was degassed by passage of nitrogen. The following effects were observed; Irr 7.43 was prevented by close proximity of other peaks. Irr 6.88 gave A= 1.80 at 4.55, A= 0.60 at 3.73 and A= 0.80 at 3.06.

Methylation and analysis. The procedure was not carried out on this compound.

N^α-Benzyloxycarbonyl-N^τ-phenacylhistidine methyl ester. LII

Preparation. The compound had been previously prepared in this laboratory.

δ_{H} (CDCl₃); 3.13 (2H, q of d, β CH₂), 3.73 (3H, s, OCH₃), 4.65 (1H, m, α CH), 5.13 (2H, m, PhCH₂), 5.33 (2H, s, NCH₂), 6.31 (1H, d, NH), 6.69 (1H, s, Im5), 7.35 (6H, m, Ar), 7.55 (2H, m, Im2 and Ar), 7.68 (1H, m, Ar), 7.96 (2H, m, Ar).

n.O.e. measurement. The sample was degassed by passage of nitrogen. The following effects were observed; Irr 7.55 was prevented by close proximity of other peaks. Irr 6.69 gave $\Lambda = 1.40$ at 5.13, $\Lambda = 1.40$ at 4.65, and $\Lambda = 1.00$ at 3.13

Methylation and analysis. The procedure was not carried out on this compound.

N^α-Benzyloxycarbonyl-N^π-t-butoxymethylhistidine methyl ester. X

Preparation. The material was not prepared as described in chapter 1, but was a kind gift of Dr R. Colombo⁴⁶ who prepared it according to the procedure outlined on p. 20. δ_{H} (CDCl₃); 1.25 (9H, s, (CH₃)), 3.14 (2H, m, β CH₂), 3.73 (3H, s, OCH₃), 4.63 (1H, m, α CH), 5.08 (2H, s, PhCH₂), 5.22 (2H, dist d, NCH₂), 5.90 (1H, d, NH), 6.80 (1H, s, Im4), 7.31 (5H, m, Ph), 7.48 (1H, s, Im2).

n.O.e. measurement. The sample was degassed by passage of nitrogen. The following effects were observed; Irr 7.48 gave $\Lambda = 1.09$ at 5.22. Irr 7.31 gave $\Lambda = 0.73$ at 5.08. Irr 6.80 gave $\Lambda = 0.41$ at 4.63.

Methylation and analysis. Methylation was performed using neat methyl iodide. The 3-methylhistidine peak was eluted after 58 min. Peak areas; NH₃; 0.2358, 1-methylhistidine; 0.0563 (7 nmol ml⁻¹), histidine; 0.3870 (34 nmol ml⁻¹), 3-methylhistidine; 2.4656 (228 nmol ml⁻¹). Extent of reaction 85.8 %. Isomeric excess 96.9 %

N^α-Benzyloxycarbonyl-N^π-t-butoxymethylhistidine. XI

Preparation. The compound was prepared by hydrolysis of the preceding material. δ_H (D₆ DMSO); 1.19 (9H, s, (CH₃)₃), 3.00 (2H, m, β CH₂), 4.32 (1H, m, αCH), 5.01 (2H, m, PhCH₂), 5.33 (2H, dist d, NCH₂), 6.70 (1H, s, Im4), 7.32 (5H, m, Ar), 7.61 (1H, d, NH), 7.69 (1H, s, Im2).

n.O.e. measurement. The sample was degassed by alternate freezing and pumping. The following effects were observed. Irr 7.69 gave Λ = 0.90 at 5.33. Irr 7.32 gave Λ = 0.80 at 5.01. Irr 6.70 gave Λ = 1.40 at 4.32.

Methylation and analysis. Methylation was performed using neat methyl iodide. The 3-methylhistidine peak was eluted after 58 min. Peak areas; NH₃; 0.2465, 1-methylhistidine; nil, histidine; 0.0720 (6 nmol ml⁻¹), 3-methylhistidine; 0.5182 (48 nmol ml⁻¹). Extent of reaction 88 %.

Isomeric excess 100 %.

N^α-Benzyloxycarbonyl-N^π-t-butoxymethylhistidine methyl ester. X

Preparation. This material was prepared directly by reaction of N^α-benzyloxycarbonylhistidine methyl ester with t-butylchloromethyl ether. Following chromatography on silica gel the yield was 24 %. δ_H (CDCl₃); 1.20 (9H, s, (CH₃)₃), 3.08 (2H, q of d, β CH₂), 3.69 (3H, s, OCH₃), 4.62 (1H, m, αCH), 5.11 (2H, d, PhCH₂), 5.23 (2H, s, NCH₂), 6.30 (1H, d, NH), 6.80 (1H, s, Im5), 7.36 (5H, m, Ph), 7.52 (1H, s, Im2).

n.O.e. measurement. The sample was degassed by passage of nitrogen. The following effects were observed; Irr 7.52 gave Λ = 1.90 at 5.23. Irr 7.36 gave Λ = 0.90 at 5.11. Irr 6.80 gave Λ = 1.50 at 5.23 and Λ = 0.90 at 3.08.

Methylation and analysis. Methylation was performed using neat methyl iodide. The elution time for the 1-methylhistidine peak was not measureable. Peak areas; NH₃; 0.7305, 1-methylhistidine; 3.6270 (452

nmol ml⁻¹), histidine; 0.3370 (30 nmol ml⁻¹), 3-methylhistidine; nil.

Extent of reaction 94 %. Isomeric excess 100 %.

N^α-Benzyloxycarbonyl-N^π-methoxyethoxymethylhistidine methyl ester. XLIII.

Preparation. The compound was prepared as described by Colombo et al.⁴⁶ via N^α-benzyloxycarbonyl-N^π-t-butoxycarbonylhistidine methyl ester. δ_{H} (CDCl₃); 3.16 (2H, m, β CH₂), 3.32 (3H, s, CH₂OCH₃), 3.48 (4H, bs, CH₂ CH₂), 3.73 (3H, s, OCH₃), 4.64 (1H, q, α CH), 5.08 (2H, s, PhCH₂), 5.29 (2H, s, NCH₂), 5.83 (1H, d, NH) 6.84 (1H, s, Im4), 7.31 (5H, m, Ph), 7.50 (1H, s, Im2).

n.O.e. measurement. The sample was degassed by passage of nitrogen. The following effects were observed. Irr 6.84 gave A= 2.00 at 4.64, A= 0.60 at 3.73 and A= 0.60 at 3.16. Irr 7.50 gave A= 2.20 at 5.83 and A= 0.80 at 3.48.

Methylation and analysis. Methylation was performed using neat methyl iodide. The Mem group was removed from the methylated imidazolium salt by treatment with anhydrous zinc bromide, prior to heating with the constant-boiling HCl. The elution time for the 3-methylhistidine peak was 60 min. Peak areas; NH₃; 0.8318, 1-methylhistidine; nil histidine; nil, 3-methylhistidine 0.2700 (25 nmol ml⁻¹). Extent of reaction 100 % , Isomeric excess 100 % .

N^α-Benzyloxycarbonyl-N^π-methoxyethoxymethylhistidine methyl ester. XLIV.

Preparation. The compound was prepared directly using Mem chloride as described by Colombo et al.⁴⁶ δ_{H} (CDCl₃); 3.10 (2H, oct, β CH₂), 3.37 (3H, s, CH₂OCH₃), 3.50 (4H, s, CH₂CH₂), 3.72 (2H, s, OCH₃), 4.63 (1H, m, α CH), 5.13 (2H, s, PhCH₂), 5.27 (2H, s, NCH₂), 6.28 (1H, d, NH), 6.80 (1H, s,

Im5), 7.35 (5H, m, Ar), 7.49 (1H, s, Im2).

n.o.e. measurement. The sample was degassed by passage of nitrogen. The following effects were observed. Irr 7.49 gave $\Lambda = 2.00$ at 5.27, and $\Lambda = 1.20$ at 3.50. Irr 6.80 gave $\Lambda = 2.00$ at 5.27, $\Lambda = 1.00$ at 3.50 and a small Λ at 3.10.

Methylation and analysis. Methylation was performed using neat methyl iodide; the Mem group was removed from the methylated imidazolium salt by treatment with anhydrous zinc bromide, prior to heating with constant-boiling HCl. The elution time for the 1-methylhistidine peak was 41 min. Peak areas; NH_3 ; 1.414, 1-methylhistidine; 0.2463 (31 nmol ml⁻¹), histidine; 0.3224 (28 nmol ml⁻¹), 3-methylhistidine; nil. Extent of reaction 52 %. Isomeric excess 100 % .

N ^{∞} -Benzyloxycarbonyl-N ^{π} -trimethylsilylethoxymethylhistidine methyl ester. XLV.

Preparation. The compound was prepared as described by Colombo et al.⁴⁶ via N ^{∞} -benzyloxycarbonyl-N ^{γ} -t-butoxycarbonylhistidine methyl ester. δ_{H} (CDCl₃); -0.04 (9H, s, Si (CH₃)₃), 0.90 (2H, q, CH₂Si), 3.13 (2H, m, β CH₂), 3.45 (2H, q, OCH₂), 3.71 (3H, s, OCH₃), 4.65 (1H, q, α CH), 5.08 (2H, s, PhCH₂), 5.19 (2H, s, NCH₂), 5.76 (1H, d, NH), 6.83 (1H, s, Im4), 7.33 (5H, m, Ph), 7.48 (1H, s, Im2).

n.o.e. measurement. The sample was degassed by passage of nitrogen. The following effects were observed. Irr 7.48 gave $\Lambda = 0.6$ at 6.83, $\Lambda = 1.60$ at 5.19, and $\Lambda = 1.00$ at 3.45. Irr 6.83 gave $\Lambda = 1.20$ at 4.65, $\Lambda = 0.60$ at 3.71 and $\Lambda = 0.50$ at 3.13. Irr 5.19 gave $\Lambda = 13.2$ at 7.48, $\Lambda = 2.60$ at 4.65, $\Lambda = 4.30$ at 3.45, $\Lambda = 2.00$ at 3.13 and $\Lambda = 0.80$ at 0.90. Irr 5.08 gave $\Lambda = 2.0$ at 7.33.

Methylation and analysis. Methylation was performed using neat methyl iodide. The elution time for the 3-methylhistidine peak was 62 min. NH_3

and 3-methylhistidine peaks only were observed, no numerical data were available due to problems with baseline. Extent of reaction 100% .

Isomeric excess 100% .

N^{α} -Benzyloxycarbonyl- N^{γ} -trimethylsilylethoxymethylhistidine methyl ester.

XLVI

Preparation. The compound was prepared directly using Sem chloride as described by Colombo et al. δ_H (CDCl₃); -0.02 (9H, s, Si (CH₃)₃) 0.88 (2H, t, CH₂Si), 3.10 (2H, q of d, β CH₂), 3.45 (2H, t, OCH₂), 3.71 (3H, s, OCH₃), 4.63 (1H, m, α CH), 5.12 (2H, s, PhCH₂), 5.18 (2H, s, NCH₂), 6.26 (1H, d, NH), 6.79 (1H, s, Im5), 7.33 (5H, m, Ph), 7.48 (1H, s, Im2).

n.o.e. measurements. The sample was degassed by passage of nitrogen. The following effects were observed. Irr 7.48 gave $\Lambda = 1.40$ at 5.18. Irr 6.79 gave $\Lambda = 1.50$ at 5.18. Simultaneous irr at 5.18 and 5.12 gave $\Lambda = 5.50$ at 7.48, $\Lambda = 5.40$ at 6.79 and $\Lambda = 1.8$ at 3.45.

Methylation and analysis. Methylation was performed using neat methyl iodide. The elution time for the 1-methylhistidine peak was 42 min. Peak areas; NH₃; 0.2520, 1-methylhistidine; 0.5274 (66 nmol ml⁻¹), histidine; trace, 3-methylhistidine; nil. Extent of reaction 95% . Isomeric excess 100% .

N^{α} -Benzyloxycarbonyl- N^{π} -benzylhistidine. XLVII

Preparation. This material had been previously prepared in this laboratory, and was purified and characterised further; m.p. 148-9^o, $(\alpha)_D^{20} = 9.15$ (C = 0.754, DMSO). Found C, 65.3; H, 5.4; N, 10.8. C₂₁H₂₁N₃O₄ · 0.5H₂O requires C, 65.0; H, 5.7; N, 10.8% . δ_H (D₆ DMSO); 2.85 (2H, q of d, β CH₂), 4.15 (1H, m, α CH), 5.03 (2H, s, PhCH₂), 5.20 (2H, s, NCH₂), 6.77 (1H, s, Im4), 7.10 (2H, d, Ph), 7.34 (7H, m, Ph), 7.68 (1H, d, Ph), 7.72 (1H, s, Im2)

n.O.e. measurements. The sample was degassed by alternate freezing and pumping. The following effects were observed. Irr 7.72 gave $\Lambda = 4.00$ at 7.10, $\Lambda = 1.53$ at 6.77, $\Lambda = 1.50$ at 5.20 and $\Lambda = 2.00$ at 4.15. Irr 6.77 gave $\Lambda = 2.20$ at 4.15. Irr 5.20 gave $\Lambda = 10.94$ at 7.72, $\Lambda = 14.00$ at 7.10, $\Lambda = 2.00$ at 4.15 and $\Lambda = 0.80$ at 2.85.

Methylation and analysis. Attempted methylation using methyl iodide in DMF was unsuccessful, and following hydrolysis in constant-boiling HCl only histidine could be detected.

N^{α} -Benzyloxycarbonyl- N^{π} -benzylhistidine methyl ester. LVIII

Preparation. The material had been previously prepared in this laboratory. δ_H (CDCl₃); 2.98 (2H, m, β CH₂), 3.67 (3H, s, OCH₃), 4.51 (1H, q, α CH), 4.99 (2H, m, NCH₂ or PhCH₂), 5.08 (2H, m, NCH₂ or PhCH₂), 5.69 (1H, d, NH), 6.82 (1H, s, Im4), 6.98 (2H, m, Ar) 7.31 (8H, m, Ar), 7.42 (1H, s, Im2).

n.O.e. measurement. The sample was degassed by passage of nitrogen. The following effects were observed. Irr 7.42 and 7.31 gave $\Lambda = 2.40$ at 6.98, and 1.50 at 4.99. Irr 6.98 and 6.82 gave $\Lambda = 1.00$ at 5.69, $\Lambda = 1.50$ at 4.51, $\Lambda = 0.80$ at 3.67, and $\Lambda = 0.70$ at 2.98. Irr 5.08 and 4.99 gave $\Lambda = 10.8$ at 7.42, $\Lambda = 6.20$ at 6.98, a negative Λ at 5.69, $\Lambda = 2.60$ at 4.51 and $\Lambda = 1.80$ at 2.98.

Methylation and analysis. In consequence of the negative result in the case of the free acid, this procedure was not attempted.

N^{α} -Benzyloxycarbonyl- N^{π} -benzylhistidine. LIX

Preparation. The compound was obtained from the Sigma chemical company, lot number 91C-0320. It was further characterized as follows; m.p. 208-10°, (α)_D²⁰ + 6.06 (C = 0.81, AcOH), Found; C, 65.7; H, 5.6; N, 11.0;

$C_{21} H_{21} N_3 O_4 \cdot 0.25 H_2 O$ requires C, 66.0; H, 5.6; N, 10.9 %. δ_H (D_6 DMSO); 2.84 (2H, q of d, β CH_2), 4.22 (1H, m, α CH), 5.00 (2H, s, $PhCH_2$), 5.13 (2H, s, NCH_2), 6.90 (1H, s, Im5), 7.21 (2H, m, Ph), 7.33 (7H, m, Ph), 7.50 (1H, d, Ph), 7.71 (1H, s, Im2).

n.O.e. measurement. The sample was degassed by alternate freezing and pumping. The following effects were observed. Irr 7.71 gave $\Lambda = 1.20$ at 7.21, and $\Lambda = 1.70$ at 5.13. Irr 6.90 gave $\Lambda = 1.60$ at 5.13 and $\Lambda = 1.20$ at 4.22. Irr 5.13 gave $\Lambda = 13.60$ at 7.71, $\Lambda = 6.20$ at 7.21 and $\Lambda = 10.40$ at 6.90.

Methylation and analysis. The procedure was not attempted on this compound.

N^α -Benzyloxycarbonyl- N^γ -benzylhistidine methyl ester. LXI

Preparation. The sample was of commercial origin. δ_H ($CDCl_3$); 3.06 (2H, oct, β CH_2), 3.64 (3H, s & rotamers, OCH_3), 4.61 (1H, quin, α CH), 5.02 (2H, s, NCH_2), 5.10 (2H, s, $PhCH_2$), 6.63 (1H, s, Im5), 7.33 and 7.10 (10 H, m, Ar), 7.42 (1H, s, Im2).

n.O.e. measurement. The sample was degassed by passage of nitrogen. The following effects were observed. Irr 7.42 gave $\Lambda = 1.80$ at 5.02. Irr 6.63 gave $\Lambda = 0.80$ at 7.10, $\Lambda = 1.40$ at 5.02, $\Lambda = 1.00$ at 4.61 and $\Lambda = 0.80$ at 3.06. Irr between 5.10-5.02 gave $\Lambda = 6.80$ at 7.42, $\Lambda = 2.80$ at 7.33 and 7.10, and $\Lambda = 6.60$ at 6.33

Methylation and analysis. The procedure was not attempted on this compound.

N^α -t-Butoxycarbonyl- N^γ -benzylhistidine. LVI

Preparation. The compound was obtained from the Sigma chemical company.

Lot number 91C-0320. δ_{H} (D_4MeOH); 1.38 (9H, s, $(\text{CH}_3)_3$), 2.92 and 3.12 (2H, d of q, βCH_2), 4.26 (1H, t, αCH), 5.26 (2H, s, PhCH_2), 7.11 (1H, s, Im5), 7.20 (5H, m, Ph), 8.24 (1H, s, Im2).

n.O.e. measurement. For these measurements the spectra were measured in deuteriochloroform, the samples were degassed by passage of nitrogen. The following effects were observed; Irr 7.81 gave $\Lambda = 1.7$ at 5.06 (N- CH_2 -Ph). Irr 6.69 gave $\Lambda = 1.2$ at 5.06

Methylation and analysis. The procedure was not attempted on this compound.

N^{α} -t-Butoxycarbonyl- N^{γ} -benzylhistidine methyl ester. LVII

Preparation. The sample was prepared by Dr. R. Colombo. δ_{H} (CDCl_3); 1.44 (9H, s, $(\text{CH}_3)_3$), 3.05 (2H, dist q of d, βCH_2), 3.65 (3H, s, OCH_3), 4.53 (1H, quin, αCH), 5.05 (2H, s, PhCH_2), 5.92 (1H, d, NH), 6.64 (1H, s, Im5), 7.13 (2H, m, Ph), 7.34 (3H, m, Ph), 7.38 (1H, s, Im2).

n.O.e. measurements. The sample was degassed by passage of nitrogen. The following effects were observed. Irr 7.38 gave $\Lambda = 0.90$ at 7.13 and $\Lambda = 2.40$ at 5.05. Irr 6.64 gave $\Lambda = 2.20$ at 5.05 and $\Lambda = 0.80$ at 3.05. Irr 5.05 gave $\Lambda = 6.5$ at 7.38, $\Lambda = 4.60$ at 7.13, $\Lambda = 5.80$ at 6.64 and a small negative Λ at 5.92.

Methylation and analysis. The procedure was not attempted on this compound.

N^{α} -t-Butoxycarbonyl- N^{π} -benzylhistidine methyl ester. LVI

Preparation. The sample was prepared by Dr. R. Colombo. δ_{H} (CDCl_3); 1.42 (9H, s, $(\text{CH}_3)_3$), 2.97 (2H, oct, βCH_2), 3.72 (3H, s, OCH_3), 4.47 (1H, m, αCH), 5.09 (2H, d, NCH_2), 5.17 (1H, m, NH), 6.85 (1H, s, Im4),

7.06 (2H, m, Ph), 7.32 (3H, m, Ar), 7.47 (1H, s, Im2).

n.o.e. measurements. The sample was degassed by passage of nitrogen. The following effects were observed. Irr 7.47 gave $\Lambda = 1.70$ at 5.09. Irr 6.85 gave $\Lambda = 2.50$ at 4.47, and Λ approx 1.5 at 2.97. Irr 5.17-5.09 gave $\Lambda = 2.80$ at 7.47, $\Lambda = 6.50$ at 7.06, $\Lambda = 6.0$ at 4.47, and $\Lambda = 2.05$ at 2.97.

Methylation and analysis. The procedure was not attempted on this compound.

N^{α} -Benzyloxycarbonyl- N^{γ} -p-toluenesulphonylhistidine methyl ester.XLVIII

Preparation. The compound had been previously prepared in this laboratory by Rathbone.⁵³ δ_H (CDCl₃), 2.43 (3H, s, p CH₃), 3.04 (2H, m, β CH₂), 3.64 (3H, s, OCH₃), 4.62 (1H, sex, α CH), 5.10 (2H, s, PhCH₂), 5.92 (1H, bd, NH), 7.05 (1H, s, Im5), 7.29-7.40 (7H, m, Ar), 7.78 (2H, d, Ar), 7.89 (1H, d, Im2).

Cross-ring coupling constant. This was measured to be 1.26 Hz; within the expected range.

n.o.e. measurements. Such measurements are not appropriate for a compound of this structure.

Methylation and analysis. Methylation was performed using trimethyloxonium tetrafluoroborate in dichloromethane. The elution time for the 1-methylhistidine peak was 47 min. Peak areas; NH₃; 0.1155, 1-methylhistidine; 0.0585 (8 nmol ml⁻¹), histidine; 0.1750 (16 nmol ml⁻¹), 3-methylhistidine; nil. Extent of reaction 32 %. Isomeric excess 100 %.

N^{α} -Benzyloxycarbonyl- N^{γ} -piperidinocarbonylhistidine methyl ester.XLIX

Preparation. To a solution of N^{α} -benzyloxycarbonylhistidine methyl ester (3.03 g, 10 mmol) in dry benzene (15 ml) was added triethylamine (1.01 g, 10 mmol) and piperidinocarbonyl chloride (1.33 g, 10 mmol). The mixture

was heated under reflux for 2h. and then cooled. After filtration to remove triethylammonium chloride the solution was washed twice with water and again twice with a dilute solution of sodium bicarbonate. Drying (MgSO_4) and evaporation of the benzene gave a yellow oil, which solidified to a pale yellow solid on trituration with petrol. The yield at this stage was 75 %. Recrystallization from ether gave the title compound as colourless crystals (1.6 g, 39 %). M.p. $77-8^\circ$ (lit $77-9^\circ$),³⁴ $(\alpha)_D^{20} -2.31^\circ$ ($C=1.04$, MeOH), δ_H (CDCl_3); 1.66 (6H, m, pipCH_2), 3.12 (2H, m, βCH_2), 3.50 (4H, m, CH_2NCH_2), 3.73 (3H, s, OCH_3), 4.67 (1H, m, αCH), 5.13 (2H, s, ArCH_2), 6.12 (1H, d, NH), 6.93 (1H, s, Im5), 7.2 (5H, m, Ar), 7.77 (1H, s, Im2). Found C, 61.2; H, 6.4; N, 13.5; $\text{C}_{21}\text{H}_{26}\text{N}_4\text{O}_5$ requires C, 60.9; H, 6.3; N, 13.5 % .

n.Oe. measurements. Such measurements are not appropriate for a compound of this structure.

Methylation and analysis. Methylation was performed using methyl iodide in dimethylformamide. The elution time for the 1-methylhistidine peak was 46 min. Peak areas; NH_3 ; 0.1726, 1-methylhistidine; 0.3065 (38 nmol ml^{-1}), histidine; 0.3442 (30 nmol ml^{-1}), 3-methylhistidine; nil. Extent of reaction 56 % . Isomeric excess 100 % .

N^α -Benzyloxycarbonyl- N^π -mesitylmethoxymethyl histidine. LXI

Preparation. Compound XXV was dissolved in glacial acetic acid (60 ml). After 24 h. at R.T. the acetic acid was removed and the white foam was dissolved in a mixture of methanol (60 ml) and sodium hydroxide solution (1M; 18 ml). After 20 min. the reaction mixture was diluted with water (120 ml) and extracted with ether (2 x 100 ml). The aqueous layer was acidified to pH 4.5 by addition of HCl (1M) and extracted

with chloroform (6 x 100 ml). The extracts were combined, dried and evaporated to a white foam which was dissolved in a little ethyl acetate and precipitated by addition of petrol (400 ml) to give the title compound (2.12 g, 78 %). M.p. 135-7° C, $(\alpha)_D^{20} + 41.1^\circ$ (C = 1, CHCl₃), δ_H (D₆ DMSO); 2.12 (6H, s, o-CH₃), 2.19 (3H, s, p-CH₃), 3.01 (2H, q of d, β CH₂), 4.14 (1H, m, α CH), 4.34 (2H, m, Ar-CH₂), 5.00 (2H, s, PhCH₂), 5.40 (2H, q, NCH₂), 6.73 (1H, s, Im4), 6.78 (2H, s, m-CH), 7.32 (5H, m, Ph), 7.75 (1H, s, Im2). Found: C, 65.5; H, 6.4; N, 10.0, C₂₅H₂₉N₃O₅ · 0.5 H₂O requires C, 65.2; H, 6.5; N, 9.1 % .

n.O.e. measurements. The sample was degassed by alternate freezing and pumping. The following effects were observed. Irr 7.75 gave $\Lambda = 0.90$ at 5.40, and $\Lambda = 0.60$ at 4.34 . Irr 7.32 gave $\Lambda = 1.80$ at 5.00 and $\Lambda = 0.80$ at 4.14. Irr 6.78 gave $\Lambda = 2.90$ at 4.14 and $\Lambda = 3.00$ at both 2.19 and 2.12.

Methylation and analysis. The procedure was not attempted on this compound.

N ^{α} -t-Butoxycarbonyl-N ^{π} -t-butoxymethylhistidine methyl ester. LXII

Preparation. The compound had been prepared in this laboratory during work on this imidazole protecting group. δ_H (CDCl₃); 1.28 (9H, s, (CH₃)₃ of Bum), 1.41 (9H, s, (CH₃)₃ of Boc), 3.15 (2H, q of d, β CH₂), 3.78 (3H, s, OCH₃), 4.55 (1H, m, α CH), 5.28 (2H, s, NCH₂), 5.44 (1H, d, NH), 6.85 (1H, s, Im4), 7.62 (1H, s, Im2).

n.O.e. measurements. The sample was degassed by passage of nitrogen. The following effects were observed. Irr 7.62 gave $\Lambda = 1.80$ at 5.28. Irr 6.85 gave no Λ . Irr 5.28 gave $\Lambda = 5.10$ at 7.62, $\Lambda = 3.00$ at 4.55, $\Lambda = 2.10$ at 3.15 and $\Lambda = 3.10$ at 1.28.

Methylation and analysis. The procedure was not attempted on this compound.

N[∞]-Fluoren-9-ylmethoxycarbonyl-N^τ-piperidinylnhistidine.CXXIV

Preparation. The sample was a kind gift of Dr. J.D. Richards.¹³⁰ δ_H (CD Cl₃); 1.67 (6H, vbs, Ppc CH₂ (3-5)), 3.29 (2H, q of d, β CH₂), 3.50 (4H, d, CH₂NCH₂), 4.26 (1H, t, FmocH), 4.44 (2H, d, Fmoc CH₂), 4.58 (1H, bm, α CH), 5.88 (1H, d, NH), 6.95 (1H s, Im5), 7.38 (4H, dist. d of t, Ar), 7.63 (2H, d, Ar), 7.79 (2H, d, Ar), 8.00 (1H, s, Im2).

Cross-ring coupling constant. This was measured to be 1.7 Hz, which is an unusually high value, indicative nevertheless of tele-substitution.

n.O.e. measurements. Such measurements are not appropriate for a compound of this structure.

Methylation and analysis. Methylation was performed using neat methyl iodide. The elution time for the 1-methylhistidine peak was 44 min. Peak areas; NH₃; 0.1262, 1-methylhistidine; 0.1250 (16 nmol ml⁻¹), histidine; 0.0700 (6 nmol ml⁻¹), 3-methylhistidine; nil. Extent of reaction 72 % . Isomeric excess 100 % .

N[∞]-Fluoren-9-ylmethoxycarbonyl-N^τ-t-butoxycarbonylnhistidine.L

cyclohexylamine salt.

Preparation. The sample was a kind gift of Dr. J.D. Richards.¹³⁰

n.O.e. measurements. Such measurements are not appropriate for a compound of this structure. .

Methylation and analysis. Methylation was performed using a solution of methyl iodide in dimethylformamide (20 %). The elution time for the 1-methylhistidine peak was 45 min. Peak areas; NH₃; 0.0759, 1- methyl- histidine; 0.0676 (8.4 nmol ml⁻¹), histidine; 0.0270 (2 nmol ml⁻¹), 3-methylhistidine; nil. Extent of reaction 84 % . Isomeric excess 100 % .

CHAPTER 7. Preparation of haloacyl and pyrimidine derivatives of
compounds containing the guanidine function.

2-Phenylethylguanidine hemisulphate. LXIII

The compound was prepared by the general method of Braun.¹³¹

2-Phenylethylamine (32 ml, 250 mmol) and S-methylisothiuronium hemisulphate (30 g, 250 mmol) were heated under reflux in water (350 ml) during 4 h. A gentle flow of nitrogen was passed over the mixture to remove evolved thiomethanol. Removal of the water and recrystallization from ethanol, followed by washing with ether and drying under a vacuum gave the required material (37 g, 70%). The compound was described previously less the following additional data: M.p. 174-5°C (lit.⁸⁷ 168-71°C) δ_C (D₆ DMSO) 35 (t, dec-s, NCH₂), 126 (d dec-s, Ar(4)), 129 (m dec-bd, Ar (2,3,5,6)), 139 (s, Ar (1)), 158 (s, guan C).

Reaction of 2-Phenylethylguanidine with Chloroacetyl Chloride.

2-Phenylethylguanidine free base was obtained from the hemisulphate by neutralisation with concentrated sodium hydroxide, followed by evaporation of the water and extraction of the residue with ether. The ether eal solution was dried, filtered and evaporated to an oil, which was protected from the atmosphere.

To a solution of the guanidine (5 g, 20 mmol) in dry THF (40 ml) was slowly added an excess of chloroacetyl chloride (approx 5 g). A white precipitate appeared during the addition, but redissolved. After a few minutes removal of the solvent gave a yellow oil, which was washed with ether. A small aliquot (380 mg) was chromatographed on silica gel using a Chromatotron. The earlier fractions, R_f 0.75 appeared to contain the disubstituted derivative, N-(2-Phenylethyl)-N', N'' - bischloroacetyl-guanidine, as a mixture of δ , ω and ω, ω disubstituted compounds.

δ_H (CDCl₃) 2.85 (2H, t, PhCH₂), 2.93 (2H, t, PhCH₂), 3.57 2H, q, CH₂NH), 3.74 (2H, q, CH₂NH), 4.02, 4.06, 4.11, 4.16 (4H, 4 X s, CHCl₂), 6.60

(2H, b, NH) 7.23 (10H, m, Ar), 9.02 (2H, b, NH). m/z (NH₃) DCI (318 56% NH⁺_{35,37}), 316 (100, NH⁺_{35,35}), 198 (11).

Methyl difluoroacetate.

Following the procedure of Tolman¹³², difluoroacetic acid (4.29 g, 45 mmol) and dimethylphthalate (14.11 g, 73 mmol) were heated to 150 °C with stirring, together with a little sulphuric acid (0.3 ml). The temperature was then increased and all the volatile materials were distilled from the reaction mixture through a fractionating column. The collected fractions were assessed by g.l.c. and the appropriate ones were dried over P₂O₅ and redistilled in a rotary vacuum oven to give the required material as an oil (2.82 g, 53%). B.p. 85 °C δ_{H} (60MHz, CCl₃), 3.90(3H, s, CH₃), 5.00, 5.85, 6.75(1H, t, CH₂F₂).

N-(2-Phenylethyl)-N'-difluoroacetylguanidine.LXV

Methyldifluoroacetate (1.10 g, 10 mmol) was added to a solution of 2-phenylethylguanidine hemisulphate in freshly prepared methanolic sodium methoxide (40 ml; 280 mg, 12 mmol). The reaction mixture was heated under reflux with stirring for 3h. in a gentle stream of dry nitrogen, cooled and allowed to stand overnight. Evaporation of the solvent followed by acidification (dilute HCl) gave only oily droplets. The solution was extracted with ether, the ether layer was dried (HgSO₄) and evaporated, and the oily residue was quickly chromatographed on silica gel (MeOH/CHCl₃ 6%). The bulk of the material appeared to be a bis-difluoroacetyl derivative, but it decomposed quickly to an intractable oil. The most stable material (R_f 0.5) appeared to be the title compound (30 mg 3%) δ_{H} (C₂H₅Cl, 250 MHz) 2.86(2H, t, PhCH₂), 3.34(0.5H, m, NH), 3.60 (2H, q, NCH₂), 5.64, 5.87, 6.09(1H, t, CH₂F₂), 6.37(1H, m, NH), 7.33(6.5H, m,

Ar & NH). However this material was unstable in air, and a t.l.c. examination showed the starting material guanidine to be present.

2(2-Phenylethylamino)-4,6-dihydroxypyrimidine.LXVII

To a dilute solution of sodium ethoxide in ethanol (100 ml) prepared freshly from sodium (1.1 g, 50 mmol), was added 2-phenylethylguanidine hemisulphate (3.9 g, 15 mmol) followed quickly by excess diethyl malonate (11.2 g, 70 mmol). The solution was heated under reflux in a gentle stream of dry nitrogen for 4 h. On cooling and evaporation of solvent, water (30 ml) was added and the pH was adjusted to between 8 and 9 with CHCl_3 . The solution was extracted with chloroform, taken to pH 7 and the precipitated solid was collected and washed with chloroform and then water. The material was recrystallized from absolute ethanol to give the title compound (1.77 g, 53%) as a white solid $R_f(\text{E3})$ 0.40. The material became bright purple after several weeks storage. M.p. $248-9^\circ\text{C}$, ν_{max} 3480 cm^{-1} δ_{H} (250 MHz , D_6 DMSO) 2.83 (2H, t, PhCH_2), 3.38 (0.6H, m, NH), 3.52 (2H, t, NCH_2), 4.62 (1H, sharp m, pyrim 5), 6.70 (0.8H, m, NH), 7.3 (5H, m, Ar), 10.55 (1.6H, m, OH). δ_{C} (63 MHz , D_6 DMSO) 35(t dec \rightarrow s, PhCH_2), 41.5 (t dec \rightarrow s, NCH_2), 79.5 (d dec \rightarrow s, pyrim. 5), 127 (ddec \rightarrow s, Ar(4)), 129 (m dec \rightarrow d, Ar (2,3,5,6)), 139.5 (s, Ar (1)), 154.5 (s, pyrim 2), 167 (broad, C-OH), m/z (NH_3 DCI) 231 (M^+ , 9%), 140 (100), 104 (21), 91 (14). Found: C, 61.7; H, 5.6; N, 18.1. $\text{C}_{12}\text{H}_{13}\text{N}_3\text{O}_2$ requires C, 62.3; H, 5.6; N, 18.2%.

Arginine methyl ester hydrochloride.LXVIII

A solution of thionyl chloride (21.6 ml) in methanol (100 ml) was prepared cautiously, and cooled to -10°C . Arginine dihydrochloride

(42 g, 200 mmol), was added, and the solution was warmed to 45°C with stirring over 1.5 h, and subsequently left for a further 18 h. at R.T. Removal of the solvent and washing of the residue gave the crude material as a white solid. This was dissolved in 100 ml methanol, and upon addition of dry ether (600 ml) gave a crystalline solid (50.8 g, 98%). This was washed with ether and dried. The analytical data were consistent with the literature.^{133,147}

N^α-t-Butoxycarbonylarginine methyl ester hydrochloride. LXXIX

Arginine methyl ester dihydrochloride (26.1 g, 100 mmol), di-t-butylidicarbonate (24 g, 110 mmol) and potassium carbonate (27.6 g, 200 mmol) were dissolved in 50% aqueous dioxan (500 ml). The reaction was stirred for 12h. and during this period the pH remained stable at 7.5. A flocculent white solid which had formed was filtered off, pressed free of solvent and recrystallized from water to give, after drying under vacuum, the title compound (12 g, 37%). M.p. 121-3°C, $(\alpha)_D^{20} = -11.8^\circ$ (c=3.49, MeOH), $\delta_H(\text{CDCl}_3)$, 1.48 (9H, s, (CH₃)₃), 1.68, 1.36 (4H, 2Xm, β & γ CH₂), 3.18 (1H, m, δ CH), 3.41 (1H, m, δ CH), 3.75 (3H, s, CH₃), 4.33 (1H, m, α CH), 5.31 (1H, d, NH). Found C, 44.9; H, 7.6; N, 16.2; C₁₂H₂₄N₄O₄ · HCl requires C, 44.9; H, 7.7; N, 17.3%.

N^α-t-Butoxycarbonyl-N^δ-2-(3,5-dihydroxy)-pyrimidyl-ornithine methyl ester. LXX

N^α-t-Butoxycarbonylarginine methyl ester hydrochloride (3.25 g, 10 mmol) was dissolved in methanol (50 ml) containing sodium methoxide (Na; 0.71 g, 31 mmol). Dimethyl malonate (2.64 g, 20 mmol) was added and the reaction was heated under reflux for 0.5 h. and subsequently allowed to stand under nitrogen for a further 12 h. The solvent was removed, the residue taken up in water (20 ml) and the pH was quickly adjusted to 4

with 5M hydrochloric acid. The aqueous solution was shaken with 30 ml ether, and the volume of ether reduced by rotary evaporation without warming to yield a pink crystalline material which recrystallized from methanol containing a little ether to give a white solid (550 mg, 16%). $R_f(E2)$ 0.6. A trace impurity (R_f 0.7) could not be removed. M.p. 187-92^o C. $\delta_H(D_6 \text{ DMSO})$ 1.37 (9H, s, $(CH_3)_3$), 1.53 (2H, m, CH_2), 1.67 (2H, m, CH_2), 3.19 (2H, m, δCH_2), 3.64 (3H, s, OCH_3), 3.97 (1H, dist. t, αCH), 4.59 (1H, s, Pyrim. CH), 6.65 (1H, v.b, δNH), 7.29 (1H, d, αCH), 10.36 (2H, b, OH), m/z (FD 19mA) 356 (M^+), (FD, 21 mA) 357 (MH^+).

2-(2-Phenylethylamino)-5,5-dimethylpyrimidine-4,6-dione.LXXIII

To a solution of 2-phenylethylguanidine hemisulphate (3.18 g, 15 mmol) in ethanolic sodium ethoxide (100 ml, Na; 1.04 g, 45 mmol) was added 2,2-dimethyldiethylmalonate (3.76 g, 20 mmol), all at once. The solution was heated under refluxing conditions during 4 h. in a gentle stream of nitrogen. Following removal of the solvent the residue was taken up in 50 ml water, and the pH was rapidly adjusted to 7-8 with conc. HCl. A white solid crystallized out immediately and was washed liberally with water and ether. After drying in vacuo it was recrystallized from absolute alcohol and re-dried to give the title compound (2.64 g, 68%). $R_f(E3)$ 0.65, m.p. 199-200^o C, μ_{max} 3260, 3130, 1720, 1665, $\delta_H(D_6 \text{ DMSO})$ 1.26 (6H, s, CH_3), 2.87 (2H, t, Ph 3.37 (1H, b, ex, NH), 3.60 (2H, t, NCH_2), 7.27 (5H, m, Ar), 10.69 (1H, b, ex, OH), $\delta_C(D_6 \text{ DMSO})$ 24 (q dec+s, CH_3), 35 (t dec+s, $PhCH_2$), 42 (t dec+s NCH_2), 47 (s, pyrim 5), 127 (d dec+s, Ar (4)), 129 (m dec+d, Ar (2,3,5,6)), 139 (s, Ar (1)), 156 (s, pyrim 2), 177 & 182 (2Xs, CO & COH).

1,1-Cyclobutanedicarboxylic acid dimethyl ester.LXXI

1,1-Cyclobutanedicarboxylic acid (2.88 g, 20 mmol) was dissolved in

methanol (10 ml). An ethereal solution of diazomethane (alcohol free) was added until the yellow colour persisted. Excess diazomethane was destroyed with a drop of acetic acid. The resulting solution was evaporated to dryness to give the required compound as an oil (3.44 g, 100%). δ_{H} (CDCl_3), 2.10 (2H, m, CH_2), 2.65 (4H, t, $\text{C}_{(2,4)}\text{H}_2$), 3.85 (6H, s, OCH_3).

2-(2-Phenylethylamino)-5-spirocyclobutylpyrimidine 4,6-dione.LXXIV

The above dimethyl ester (3.27 g, 19 mmol) was dissolved in methanolic sodium methoxide (100 ml; Na; 0.92 g, 40 mmol). 2-Phenylethyl guanidine (5.16 g, 20 mmol) was added and the reaction was heated under reflux during 40 h under an atmosphere of nitrogen. After cooling, the solvent was removed and the residue partitioned between water (30 ml) and ether (15 ml). The aqueous layer was quickly adjusted to pH 5 with concentrated hydrochloric acid whereupon a white solid was precipitated. This was washed liberally with water and ether and dried in vacuo to give the title compound (3.75 g, 73%). λ_{f} (E6) 0.10. M.p. 190-193^o C, δ_{H} (D_6 DMSO), 2.00 (2H, p, CH_2), 2.37 (4H, dist. t, $2\times\text{CH}_2$), 2.83 (2H, t, PhCH_2), 3.34 (1H, b, NH), 3.53 (2H, t, NCH_2), 7.25 (5H, m, Ph), 7.44 (1H, b, OH), δ_{C} (D_6 DMSO), 16 (t dec+s, CH_2), 29 (t dec+s, $2\times\text{CCH}_2$), 35 (t dec+s, PhCH_2), 42 (t dec+s, NCH_2), 49 (s, spiro.C), 126 (d dec+s, Ph (4)), 128 (m dec+d, Ar (2,3,5,6)), 139 (s, Ar (1)), 158 (s, pyrim 2), 177 & 181 (2x s, CO, COH), m/z (NH_3 DCI), 272 ($[\text{MH}]^+$, 100%), 180 (31), 164 (17), Found C, 64.7; H, 6.5; N, 15.5 $\text{C}_{15}\text{H}_{17}\text{N}_3\text{O}_2$ requires C, 64.4; H, 6.3; N, 15.5%

1,1-Cyclopropanedicarboxylic acid dimethyl ester.LXXII

The method described for the preparation of the cyclobutyl

LXXI

compound λ was repeated on cyclopropanedicarboxylic acid (2.08 g, 16 mmol).

This yielded the required compound as another colourless oil (2.52 g;

100%). $\delta_{\text{H}}(\text{CDCl}_3)$ 1.50 (4H, s, CH_2), 3.75 (3H, s, OCH_3)¹⁴³.

2-(2-Phenylethylamino)-5-spirocyclopropylpyrimidine 4,6-dione.LXXV

2-Phenylethylguanidine hemisulphate (3.37 g, 16mmol) was dissolved in methanolic sodium methoxide (100 ml; Na; 0.74 g, 32 mmol) and the above ester (2.52 g, 16 mmol) was added, previously dissolved in a few ml of methanol. The reaction was heated under reflux during 20 h. under an atmosphere of nitrogen, and the solvent was then evaporated. The residue was taken up in 40 ml water and the pH was adjusted quickly to 5 with dilute HCl. The precipitated solid was collected and found to be impure, so it was purified by flash chromatography (E4) R_f 0.2 and recrystallization from methanol. Drying in vacuo gave a slightly pink solid (1.2 g, 30%).

M.p. 225-35^o (indistinct) ν_{max} 1710, 1660 cm^{-1} $\delta_{\text{H}}(\text{D}_6 \text{ DMSO})$, 1.56 (4H, s, propyl CH_2), 2.84 (2H, t, PhCH_2), 3.56 (2H, t, NCH_2), 7.00 (1H, b, NH), 7.28 (5H, m, Ar) $\delta_{\text{C}}(\text{D}_6 \text{ DMSO})$ 24 (t dec \rightarrow s, propyl CH_2), 28 (s, spiro C), 35 (t dec \rightarrow s, PhCH_2) 42 (t dec \rightarrow s, NCH_2), 127 (d dec \rightarrow s, Ph(4)), 129 (m dec \rightarrow d, Ph(2,3,5,6)), 139 (s, Ph(1)), 158 (s, pyrim. C(2)), 172, 178 (s, s, C=O, C-OH), m/z (NH_3 DCI), 258 (MH^+ , 100%), 257 (H^+ , 27), 166 (20). Found C, 64.8; H, 5.9; N, 15.7. $\text{C}_{14}\text{H}_{15}\text{N}_3\text{O}_2$ requires C, 65.3; H, 5.8; N, 16.3%.

2-(2-Phenylethylamino)-4,6-dihydroxy-5-phenylpyrimidine.LXXVI

2-Phenyldiethylmalonate (16.5 g, 70 mmol) and 2-phenylethylguanidine hemisulphate (3.9 g, 15 mmol) were dissolved in ethanolic

sodium ethoxide (100 ml; Na, 1.15 g, 50 mmol). The reaction was heated under reflux in an atmosphere of dry nitrogen for 12 h. Removal of the solvent and addition of water (50 ml) followed by an adjustment of the pH to 6 resulted in the formation of a white solid. This was recrystallized from ethanol to give the title compound (1.00 g, 22%)

R_f (E2) 0.65. M.p. 210-3°C.

δ_H (D_6 DMSO) 2.84 (2H, q, $PhCH_2$), 3.56 ($\frac{1}{2}$ H, m, CO-NH), 4.08 (2H, q, CH_2NH), 7.06-7.54 (10H, m, Ar), 7.41 (1.2/3 H, bs, OH), 10.50 (1H, v.b, NH), δ_C (D_6 DMSO) 33.1 (t dec \rightarrow s, $PhCH_2$), 41.7 (t dec \rightarrow s, NCH_2), 90.4 (s, pyrim. 5), 126.8, 128.4, 129.1, 130.4 (m, Ar), 134.6, 139.2 (ipso Ar), 151.6 (s, pyrim. 2), 160.2, 161.2 (2Xs, C-OH, C=O). m/z (+ve Ar FAB HCO_2H), 308 ($[M]^+$ 100%), 105 (78). Found C, 70.1; H, 5.6; N, 13.6. $C_{18}H_{17}N_3O_2$ requires C, 70.4; H, 5.5; N, 13.7%

2,2-Difluorodiethylmalonate.LXXXV

Diethylmalonate (20 g, 125 mmol) was added to an ethanolic solution of sodium ethoxide (Na, 5.75 g, 250 mmol; 150 ml). The solution was stirred vigorously whilst being cooled over an ice bath, and the apparatus was evacuated of air. Perchloryl fluoride was admitted above the liquid surface in 50 cm³ lots by means of a gas syringe and teflon tubing. (Fig.7.1) (EXTREME CAUTION:- RISK OF EXPLOSION). The temperature was maintained between 10°C and 15°C; the absorption of gas was initially very fast, but slowed considerably after one equivalent of base was consumed. The final take-up was 95 lots (approx 22 g, 0.21 mol). The resulting solution was poured into water (500 ml) and extracted with a large volume of ether. The ethereal solution was washed with water, dried ($HgSO_4$) and evaporated without heating to give a mobile liquid. This liquid was distilled under

reduced pressure, and the distillation fractions were examined by GLC (CH_2Cl_2 , 2m X 4mm, 3% OV-17, 100°C). This enabled the required compound to be identified; the appropriate fractions were combined and purified by flash chromatography in 4% ether in hexane to give the required material as a colourless liquid (8.6 g, 35%). B.p. $79-81^\circ\text{C}$ (13 mm Hg), n_D^{20} 1.3822 (lit. ¹³⁴ 1.3800), δ_H (no solvent) 1.37(3H, t, CH_3), 4.44 (2H, q, CH_2), $\delta_C(\text{CDCl}_3)$ 13.5 (q dec \rightarrow s, CH_3), 63.6 (t dec \rightarrow s, CH_2), 101.9, 106.0 110.2 (t, not dec \rightarrow , J = 31.2H_2 , CF_2), 160.1, 160.6, 161.1 (t, not dec \rightarrow , J = 260.8H_2 , CO). m/z (Extensive G.C.M.S. data recorded, numerous very minor products). 196 (M^+) 178 ($\text{CHF}(\text{CO}_2\text{CH}_2\text{CH}_3)_2$, trace), 160 (DEH, trace).

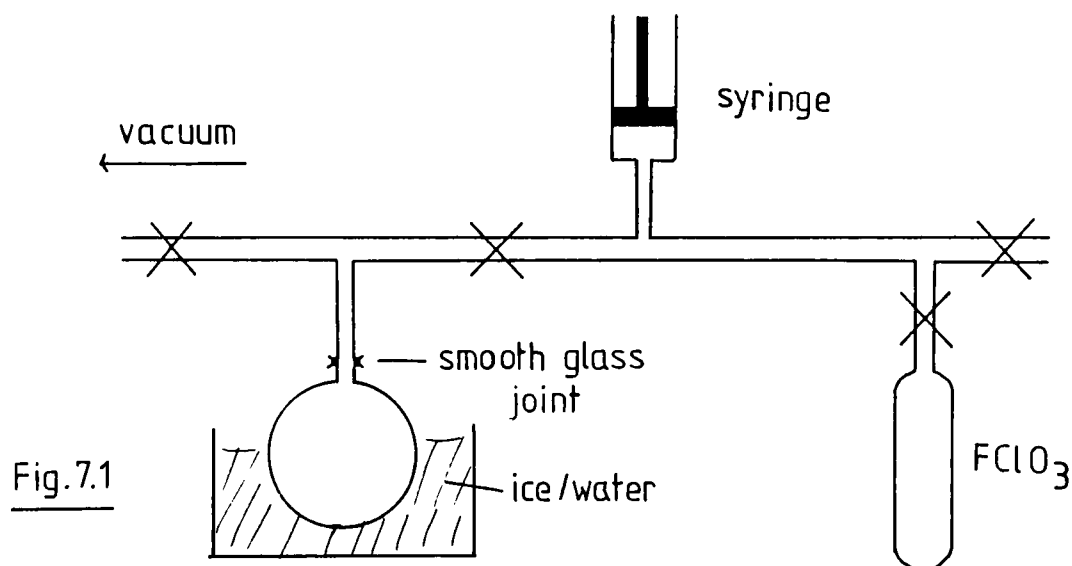

2-(2-Phenylethylamino)-5,5-difluoropyrimidine 4,6-dione.LXXXVIII

2-Phenylethylguanidine hemisulphate (1.06 g, 5 mmol) was dissolved in 40 ml of ethanolic sodium ethoxide (Na; 0.25 g, 11 mmol). 2,2-Difluorodiethylmalonate (1.31 g, 6.7 mmol) was quickly added, and the solution was heated under reflux in a slow stream of dry nitrogen during 6 h. The solution was cooled and evaporated to dryness, and the

resulting sticky solid was taken up in water (15 ml) and quickly adjusted to pH 7 with concentrated hydrochloric acid. Addition of ether (20 ml) and vigorous shaking, followed by removal of the bulk of the ether by rotary evaporation without heating gave a white solid suspended in the aqueous layer. This material was filtered off, washed copiously with ether and dried in vacuo to give the title compound (0.62 g, 46%). R_f (E3) 0.15, m.p. 140-2°C (amorphous material). δ_H (D_6 DMSO) 2.84 (2H, t, $PhCH_2$), 3.40 (2H, t, NCH_2), 7.30 (5H, m, Ph), 7.77 (0.75H, b, Ex.N/OH), 8.34 (0.75H, b, Ex.N/OH), 8.79 (0.5H b, Ex.N/OH). m/z (NH_3 DCI, decomp.) E.I 267.86 (M^+ , 0.07%) Found C; 50.7, H; 4.9, N; 14.7. $C_{12}H_{11}N_3O_2F_2 \cdot H_2O$ requires C; 50.5, H; 4.6, N; 14.7%.

An attempt was made to recrystallize this material from ethanol, but the only material recovered was an oil. This was also formed when a solution of the pyrimidine in ethanol was allowed to stand at R.T. for a few hours. The major component of this oil was a more lipophilic material R_f (E3) 0.35, but which could not be satisfactorily purified. It appeared to be N-(ethyl-2,2-difluoromalonyl)-N'-(2-phenylethyl)-guanidine. δ_H (CCl_4) 1.29 (3H, t, CH_3), 2.87 (2H, t, $PhCH_2$), 3.35 (2H, q, NCH_2), 4.26 (2H, q, OCH_2), 6.2-7.3 (2H, v.b. Exch. NH), 7.23 (5H, m, Ph), 7.67 (1H, m, NH) m/z (CI) 313.

2,2-Dichloromalonic acid, LXXVI

Initially an attempt was made to prepare diethyl-2,2-dichloromalonate by free-radical chlorination of DEM using N-chlorosuccinimide, according to the method of Büu-Hoi and Desmerseman¹³⁵. The major product is the mono-halogenated material which unfortunately could not be separated from the desired material by vacuum distillation.

A modification of the method given by Straus and Kühnel¹³⁶ was more

successful; Malonic acid (15 g, 145 mmol) was dissolved in a solution of sodium hydroxide, to neutrality, and was made up to 100 ml with ice. A cold solution of sodium hypochlorite (commercial 13%; 165 ml 280 mmol) was diluted to 500 ml and added in one portion. The reaction was allowed to warm to room temperature, with stirring, over 8h. After venting the apparatus (caution! failure to do so resulted in a fire) the solution was extracted with several 200 ml portions of ether. The ethereal solution was dried and evaporated to an oil. Taking up this oil in chloroform, followed by addition of petrol (B.p. 40-60°) gave the required compound as needle shaped crystals (2.61 g, 95%) m.p. 114-118°C. δ_{H} (D_6 DMSO 60MHz) 13.4 (b, s, OH)

Dimethyl-2,2-dichloromalonate. LXXXVII

To a solution of diazomethane in ether ^{from} (Diazald, 23 g) 3g, was added a solution of the above acid in methanol (40 mg ml⁻¹) until the colour was discharged. The solution was filtered and evaporated to an oil (2.19 g) which was purified by flash chromatography (E6) to give the required material (1.85 g, 85% on the above). δ_{H} (CDCl₃, 60 MHz) 4.0 (s, OCH₃).

Attempted preparation of 2-(2-Phenylethylamino)-5,5-dichloropyrimidine-4,6-dione. XC

2-Phenylethylguanidine hemisulphate (2.79 g, 10.8 mmol) was dissolved in methanolic sodium methoxide (Na, 0.5 g; 100ml) under nitrogen. The above ester was added, and the reaction was heated under reflux during 4h. The reaction was monitored by t.l.c. and stopped as one material (E6, R_f 0.50) began to predominate. Removal of the solvent and addition of

water (30 ml), followed quickly by adjustment of the pH to 3 with HCl resulted in the separation of an oil. Addition of a little ether and evaporation of this without heating gave a yellow crystalline solid, which was filtered off and dissolved in dichloromethane. Drying of the solution and partial evaporation gave a white crystalline solid (1.1 g). However this was not the title compound, but proved to be N-phenylethyl-N'-dichloroacetyl guanidine (37%) m.p. 179-81°C, δ_{H} ($\text{D}_2\text{O}/\text{MSO}$) 2.86 (2H, t, PhCH_2), 3.60 (2H, q, NCH_2), 6.80 (1H, s, CCl_2H), 7.29 (5H, m, Ar), 8.80 (1H, b, NH), 9.20 (2H, s, NH). δ_{C} 33.8 (t dec+s, PhCH_2), 43.0 (t dec+s, NCH_2) 66.4 (d dec+s, CCl_2H), 126.7 (d dec+s, p-Ph), 128.6 & 129.0 (d of d, dec+d o- & m-Ph), 138.0 (s, i-Ph), 153.0 (s, guan), 164.3 (s, CO). m/z (NH_3 HCl) 276 (68%, M^+_{37}), 274 (100 M^+_{35}) 240 (28) 222 (28). Found Cl 28%. $\text{C}_{11}\text{H}_{13}\text{N}_3\text{O Cl}_2$ requires Cl 26%.

Ethyl-2,2-diphenylacetate.LXXVIII

2,2-Diphenylacetic acid (21.2 g, 100 mmol) was dissolved in ethanol (200 ml) and a little benzene (15 ml) was added. 50 ml of the solvent was then distilled off and discarded (water present initially is removed in the ternary azeotrope). Dry hydrogen chloride was passed through the solution for a few minutes until it was saturated, and it was allowed to stand for a further 5 h. Following removal of the solvent the residue was dissolved in chloroform (100 ml), washed with sodium hydrogen carbonate solution and water, dried (HgSO_4) and evaporated to a small volume, whereupon it crystallized to give the required compound (23 g, 86%). Analytical data was consistent with the structure and with the literature.¹⁴⁴

2,2-diphenyldiethylmalonate.LXXIX

A dispersion of sodium hydride in oil (50%; 5 g) was washed with

hexane and suspended in dry THF. To this was added a solution of ethyl diphenylacetate (12 g, 50 mmol) in THF (50 ml) The mixture was warmed (40°C) with stirring under an atmosphere of dry nitrogen during 3 h. Ethyl chloroformate (70 ml; excess) was then added and the reaction heated under reflux during 2 h. After cooling and removal of the solvent the residue was taken up in chloroform and washed with aqueous sodium hydrogen carbonate and water. The solvent was again removed and the residual oil was distilled, the fraction b.p. 152-6°C (0.5 mbar) was the required material (2.16 g, 14%) as an oil which subsequently solidified. M.p. 54-6°C, $\delta_{\text{H}}(\text{CDCl}_3)$, 1.25 (6H, t, CH₃), 4.30 (4H, q, CH₂), 7.40 (10H, m, Ph).

Attempted preparation of 2-(2-phenylethylamino)-5,5-diphenylpyrimidine 4,6-dione.

The procedure described for the preparation of the 5,5-dimethyl compound was followed, except that initially the materials were only heated for a few moments until they dissolved. Very little solid material was obtained, and that was impure. It was purified by centrifugally accelerated chromatography using E6 as eluent. This gave a white solid which was not the title compound, but was found instead to be N-(diphenylacetyl)-N'-phenylethylguanidine $\delta_{\text{H}}(\text{CDCl}_3)$, 2.74 (2H, q, CH₂), 3.58 (2H, t, CH₂), 5.20 (1H, s, CH) 7.0-3 (15H, m, Ar). The material was not examined further.

9-Fluorenylcarboxylic acid ethyl ester.LXXXI

9-Fluorenylcarboxylic acid (4.2 g, 20 mmol) was dissolved in ethanol (100 ml) and a little benzene (15 ml). Approx. 50 ml of the solvent was

then distilled off and discarded. The apparatus was then rearranged and the remaining solution heated under refluxing conditions with gentle passage of dry hydrogen chloride into the flask. After 2 h. the volatile materials were removed under vacuum and the residue oil was dissolved in ethyl acetate (100 ml). The organic solution was washed with saturated sodium hydrogen carbonate solution (50 ml), water, dried and evaporated to an oil. Chromatographic and spectroscopic examination showed it to be the required compound (4.53 g, 95%), free from the acid.¹⁴⁵

9,9-Dimethoxycarbonylfluorene.LXXXII

Reaction of the preceding ester with sodium hydride and then ethyl chloroformate, following the same procedure as for the 2,2-diphenylmalonate above gave the required material which was recrystallised from ethanol as pale yellow crystals (2.93 g, 52%) m.p. 100-101°C (lit. 99.5°C δ_{H} (CCl₄) 1.10 (6H, t, CH₃), 4.05 (4H, q, OCH₂) 7.1-7.7 (8H, m, Ar).

Attempted preparation of 2-(2-Phenylethylamino)-5-spirofluorenylpyrimidine 4,6-dione.

The procedure described for the preparation of the 5,5-dimethyl compound was followed, except that initially the materials were only heated briefly until they dissolved. Following acidification no solid was obtained. The material was then chromatographed on silica gel (MeOH/CHCl₃ 20%) and obtained as an off-white solid, but it could not be obtained pure. It appeared from proton n.m.r. to be the product arising from loss of one of the ester groups; that is N-fluorenocarbonyl-N'-phenylethylguanidine, and that as a mixture of isomers. δ_{H} (D₆-DMSO). 2.64, 2.77 (2 s t, approx. 2:1, PhCH₂), 3.08, 3.32 (2:1, q and obscured, O₂O ex. to t and t, N(H)CH₂), 5.47 (Fluorenyl 9-H), 7.29-7.74 (Ar).

CHAPTER 8. Preparation of histidylphenylalanylarginine and modifications thereof.

N^G-Nitroarginine. XCII

To a cooled (-20°C) nitrating mixture of fuming nitric acid (40 ml) and oleum (25 ml) was added powdered arginine free base, slowly and with efficient stirring. The last portion was washed in with sulphuric acid (15 ml). The suspension was stirred for 1 h. and then poured onto ice. The pH was taken to between 8 and 9 with aqueous ammonia, and then returned to around pH 6 with glacial acetic acid. On cooling for 4 h. a white precipitate formed; this was filtered off and recrystallized from water, washed with ethanol and dried under vacuum to give the required compound (22 g, 60%). M.p. 263°C (lit.¹³⁷ 265°C). $[\alpha]_D^{20} + 19.3$ (c = 1.98, 6M HCl). (lit $[\alpha]_D + 24.1^\circ$ (c = 1.93, 2N HCl)).

N^G-Nitroarginine benzyl ester. 4-toluene sulphonate. XCIII

N^G-Nitroarginine (10 g, 45.7 mmol) and 4-toluenesulphonic acid (18 g 105 mmol) were suspended in chloroform (75 ml), and benzyl alcohol (20 ml) was added. The mixture was heated to boiling in an azeotroping apparatus designed for use with heavy entrainers, (H₂O : CHCl₃; 2:998 in lower, 992:8 in upper layer) and allowed to reach equilibrium under refluxing conditions during 8 h. The solution was cooled and the solvent evaporated to give a yellow oil which defied all attempts at immediate solidification. It was covered with ether and held at -30°C for 2 weeks. The ether was decanted and the solid broken up with a spatula under a mixture of petrol and ether. The compound was dried and obtained as the di-tosylate (21 g, 70%). The material is described in the literature as a mono-tosylate. M.p. 123-5°C. $[\alpha]_D^{20} + 11.7^\circ$ (c = 1.0, pyridine). Found: C, 48.4; H, 5.0; N 10.4. Calculated for C₂₇H₃₅O₁₀N₅S₂; C, 49.5; H, 5.3; N, 10.7%.
138

N[∞]-t-Butoxycarbonylphenylalanine. XCIV

This compound was prepared according to the method of Moroder et al.¹³⁹ Phenylalanine (33.0 g, 200 mmol) was dissolved in 0.5 M ice cold sodium hydroxide solution (400 ml), and a solution of di-t-butylidicarbonate (43.6 g, 200 mmol) in dioxan (400 ml) was added. The solution was stirred for 0.5 h. and the dioxan was removed by rotary evaporation. The aqueous solution was taken cautiously to pH3 with dilute potassium hydrogen sulphate solution and extracted with ethyl acetate (2 X 500 ml). The organic layer was washed with water, dried (Na₂SO₄) and evaporated to a white solid. This material was recrystallized from ether-40/60° petrol at -20° C, giving the required material (36.0 g, 68 %) which was identical with an authentic sample. R_f (E2) 0.70. [α]_D²⁰ - 4.17° (c = 5.44, Acetic acid). [α]₅₇₈²⁰ - 4.17° (c = 1.15, acetic acid).

N[∞]-t-Butoxycarbonylphenylalanine N-hydroxysuccinimide ester. XCV

N[∞]-t-Butoxycarbonylphenylalanine (1.327 g, 5 mmol) and N-hydroxysuccinimide (0.576 g, 5 mmol) were dissolved in dioxan (8 ml) and cooled in an ice bath. DCCI (1.031 g, 5 mmol) was dissolved in dioxan (2 ml) and added slowly. The reaction was maintained at 4° C during 12 h. After warming to RT the dicyclohexylurea was filtered off, washed with dioxan and discarded. The combined filtrate and washings were evaporated to a small volume; liberal addition of ether gave a flocculent white solid which was recrystallized from dichloromethane-30/40° petrol to give the required compound (0.72 g, 41 %). The reaction was subsequently repeated on the 40 mmol scale (11.9 g, 82 %). M.p. 150-2° C (lit. 153° C). [α]_D²⁰ -19.9° (c = 1, dioxan). (lit. -20.3° ± 1 (c = 0.76, dioxan)). δ_H (300 MHz, CDCl₃); 1.42 (9H, s, (CH₃)₃), 2.85 (4H, s, CH₂CH₂), 3.25 (2H, m, β CH₂), 4.90 (1H, m, ∞ CH), 7.32 (5H, m, Ph).

N[∞]-t-Butoxycarbonylphenylalanyl-N^G-nitroarginine benzyl ester. XCVI

A solution of N[∞]-t-butoxycarbonylphenylalanine N-hydroxysuccinimide ester (0.362 g, 1 mmol) and N^G-nitroarginine benzyl ester di-tosylate, (0.653 g, 1 mmol) dissolved in a minimum of dioxan (6 ml), was cooled in an ice bath. Triethylamine (0.28 ml, 1 mmol) was added slowly. The reaction was stirred for 48 h. and the dioxan was removed by rotary evaporation. The residue was taken up in chloroform (30 ml) and washed with equal portions of respectively; water, citric acid (0.5 M), sodium bicarbonate (0.5 M) and water. Drying (MgSO₄) and evaporation of the solvent gave a meringue which was triturated with 30/40^o petrol, ground to a fine powder and dried to give the title compound as a white powder (0.4 g, 73 %). Subsequent preparations were performed on a 10 mmol scale. The preparation was repeated successfully using the 2, 4, 5-trichlorophenyl ester, but this route offered no advantages. R_f (E4) 0.45, M.p. 143-6^o C, [α]_D²⁰ = -32.2^o (c = 1.97, CHCl₃), δ_H (CDCl₃) 1.66-1.92 (4H, m, Arg CH₂), 3.04 (4H, m, β CH₂), 3.21 (2H, b, CH₂), 4.18 (1H, t, Phe α CH), 4.37 (1H, bd, α NH), 4.60 (1H, m, α CH), 5.14 (2H, s, OCH₂), 5.27 (1H, bd, α CH), 6.93 (1H, b, NH), 7.25 (10H, m, Ar), 7.69 (2H, b, NH), 8.70 (1H, b, NH).

N[∞]-t-Butoxycarbonyl-N^π-benzyloxymethylhistidylphenylalanyl-N^G-nitroarginine benzyl ester. XCVII

The preceding Boc-protected dipeptide (1.112 g, 2 mmol) was dissolved in cold TFA (15 ml) and was allowed to stir on an ice bath during 0.5 h. The TFA was removed and the resulting material was triturated with ice-cold ether (80 ml) for 1 h. The ether was decanted and discarded, the residue washed with a further portion of ether, then dried briefly under vacuum and dissolved in DMF (5ml) to give solution A.

N[∞]-t-Butoxycarbonyl-N^π-benzyloxymethyl histidine (0.750 g, 2 mmol), HOBT

(0.297 g, 2 mmol) and DCCI (0.413 g, 2 mmol) were dissolved in DMF (4 ml). To this solution was added solution A above, previously adjusted to "pH" 9.5 by addition of triethylamine. After the reaction was complete (12 h) the crystalline precipitate of DCU was filtered off, washed and discarded. The filtrate and washings were applied to a 1.3 m column of Sephadex LH20 swollen and eluted with DMF, and chromatographed. The separation was not entirely satisfactory, so a portion of elutant containing all the required material and some impurities was re-concentrated and re-applied to the column. Appropriate fractions were evaporated to a small volume, and the title compound precipitated as a white solid by addition of ether. (841 mg, 52 %). R_F (X1) 0.80. M.p. 140-4° C. $[\alpha]_D^{20} -20.11^\circ$ (c = 0.87, CH₃OH). δ_H (D₇DMF); 1.31 (9H, s, (CH₃)₃), 1.67 (4H, m, Arg CH₂), 1.91 (2H, m, Arg CH₂), 3.30-2.95 (5H, m, α CH and 2X β CH₂), 4.40 (1H, m, α CH), 4.47 (2H, s, Bzl CH₂), 4.73 (1H, m, α CH), 5.17 (2H, s, PhCH₂OCH₂), 5.49 (2H, m, NCH₂), 6.78 (1H, s, Im 4), 6.88 (1H, d, NH), 7.25 (15H, m, Ar) 7.78 (1H, s, Im2), 8.04 (1H, d, NH), 8.17 (3H, b, guan NH), 8.55 (1H, d, NH). m/z (NH₃ DCI), 405 (5 %), 301 (8), 91 (100); (F.D.), 813 (M⁺). (Found C; 60.3, H; 6.2, N; 15.3, C₄₁H₅₁N₉O₉ requires C; 60.5, H; 6.3, N; 15.5 %).

N[∞]-t-Butoxycarbonylhistidylphenylalanylarginine. XCVIII

The preceding fully protected tripeptide (663 mg, 0.82 mmol) was dissolved in 80 % aqueous acetic acid (40 ml) in which 10% palladium on carbon catalyst (250 mg) had been suspended. Hydrogen was passed by means of a needle into the vigorously stirred solution, and vented from the apparatus. After 20 h. the passage of hydrogen was stopped and the suspension centrifuged to give a clear solution which was decanted and reduced to a small volume. This material was purified by chromatography on

a column (25 mm x 1 m) of Sephadex G10, swollen and eluted with 5 % aqueous acid. Appropriate fractions, whose u.v. absorption were monitored automatically, were pooled and freeze-dried to give a hygroscopic solid. The handling characteristics were markedly improved by slowly adding a solution of the material in DMF to a large excess of rapidly stirred ether; the white precipitate was filtered off and dried to give the title compound (431 mg, 79 %) R_f (X1) 0.55. M.p. 172-3° C. $[\alpha]_D^{20} -12.1^\circ$ (c = 0.60, methanol). δ_H (D₂O) (resolution poor); 1.14 (9H, s, (CH₃)₃), 1.36, 1.52, 1.64 (5H, 3X m, Arg CH₂), 1.77 (6H, s, CH₃CO₂⁻), 2.41 (1H, s, Arg δ CH), 2.81, 2.97 (4H, bd, β CH₂), 3.98 (1H, bm, α CH), 4.16 (1H, bm, α CH), 4.47 (1H, bm, α CH), 4.72 (1H, m, NH), 7.13 (6H, bm, Im4), 7.74 (1H, s, Im2). m/z (NH₃ DCI), 587 (7 %), 559 (MH⁺, 30), 110 (100). (Found C; 53.2, H; 7.0, N; 16.7, C₂₆H₃₈N₈O₆. 2CH₃CO₂H requires C; 53.1, H; 6.8, N; 16.5 %).

Histidylphenylalanylarginine.XCIX.

The preceding Boc-protected tripeptide diacetate (250 mg, 0.37 mmol) was dissolved in TFA and stirred for 0.5 h. The TFA was evaporated and the residue triturated with ether (X2). The ether was decanted and the residue dried briefly under vacuum, and then dissolved in a minimum of 25 % acetic acid. The material was applied to an Amberlite IRA45(OH) column (20 x 300 mm), which had been previously prepared in its acetate form, and eluted with 25 % acetic acid. Regeneration of the column to remove trifluoroacetate anion was done using 1M sodium hydroxide. Appropriate fractions (as judged by t.l.c. using the Pauli reagent) were pooled and freeze-dried to give a grey-white hygroscopic solid which was triturated with ether and dried under vacuum to give the title compound (228 mg, 97 %) as its triacetate. R_f (X1) 0.10 (Pauli and Sakaguchi), R_f 0.5 (X1, cellulose MN 300F) M.p. 108-10° C. $[\alpha]_D^{20} -4.76^\circ$ (c = 0.21, methanol). δ_H (D₂O); 1.35 (2H, m, Arg CH₂), 1.58 (3H, m, ArgCH₂), 1.77

(9H, s, CH_3CO_2^-), 2.43 (1H, s, Arg δ CH), 2.99 (4H, m, β CH_2), 3.97 (2H, m, α CH) 4.52 (1H, t, His α CH), 4.73 (1H, b, NH), 6.98 (1H, s, Im4), 7.15 (5H, m, Ar), 7.95 (1H, s, Im2). m/z, (+ve Ar FAB) 487 (v. small), 459 (MH^+ 92 %) 110 (100). (Found C, 47.4; H, 6.8; N, 18.5, $\text{C}_{21}\text{H}_{30}\text{N}_8\text{O}_4 \cdot 3\text{AcOH} \cdot 2\text{H}_2\text{O}$ requires C, 48.0; H, 6.8; N, 16.6 %).

N^{α} -t-Butoxycarbonyl- β -methylphenylalanine. C.

After several attempts the compound was prepared, using scrupulously dry apparatus, by the method of Benoiton. N^{α} -¹⁴⁰-t-butoxycarbonylphenylalanine (2.65 g, 10 mmol) was dried under vacuum at 60°C for 5h. It was dissolved along with dry methyl iodide (5 ml, excess) in THF (22 ml), and the solution was cooled over an ice bath and kept under nitrogen. Sodium hydride (0.72 g, 30 mmol) as a 50% dispersion in oil was washed with hexane, suspended in THF (8 ml), and added by means of a wide-bore syringe needle to the above solution. The reaction was stirred during 20h. After removal of the solvent the excess hydride was destroyed with water (100 ml), the aqueous solution was washed with ether (30 ml) to remove any methyl ester, then acidified with 1M citric acid solution and extracted into ethyl acetate (2 x 50 ml). The organic layer was washed with water (50 ml), sodium thiosulphate solution (5%; 2 x 50 ml), and again with water then dried (MgSO_4) and evaporated to a pale yellow oil. This was taken up in a little ether, and a slight excess of DCHA in ether was added. The precipitate which formed was collected, washed freely with ether, dissolved in a little hot methanol, and crystallised by addition of hot ether containing a little 40-60° petrol. This gave the required compound C (3.0 g, 65%) with analytical data consistent with the literature. Additionally $(\alpha)_{\text{D}}^{20} = 37.3^\circ$ (c = 0.845, CHCl_3).

N^α-t-Butoxycarbonyl-N^π-benzyloxymethylhistidyl-N^α-methylphenylalanyl-N^G-nitroarginine benzyl ester. CII.

The above DCMA salt C was released as its free acid (2 mmol) using citric acid and taken up in DMF (3 ml). Coupling to N^G-nitroarginine benzyl ester using the HOBt/DCCI method on a 2 mmol scale, followed by a routine work-up gave N^α-t-butoxycarbonyl-N^α-methylphenylalanyl-N^G-nitroarginine benzyl ester CI as a white solid (900 mg, 79%). This material was examined by N.M.R. before being taken on to the next stage

(δ_{H} (CDCl₃) 2.71, 3H, s, NCH₃). (60 MHz)

The above dipeptide (580 mg, 1.02 mmol) was deprotected in TFA (5 ml; 0.5h). The TFA was removed and the residue was triturated with ether (10 ml); the ether was decanted and the resulting white powder was washed again with ether, dried briefly and taken up in DMF (1 ml). A routine coupling by the DCCI/HOBt method with N^α-t-butoxycarbonyl-N^π-benzyloxymethylhistidine in DMF (210 mg, 1.02 mmol; 2 ml), followed after 24h. by removal of DCU by filtration gave the crude protected tripeptide. Chromatography on Sephadex LH20, eluting with DMF, followed by pooling and evaporation of appropriate fractions gave the title compound as a white meringue (450 mg, 53%) R_f (E3, cellulose) 0.55.

δ_{H} (CDCl₃), 1.42 (9H, s, (CH₃)₃), 1.69 (4H, m, Arg CH₂), 1.82 (2H, m Arg CH₂), 2.81 (3H, s, NCH₃), 3.14, 3.22 (2H, m, β CH₂), 4.50 (2H, s, OCH₂), 5.14 (2H, s, NCH₂), 5.37 (2H, q, CO₂CH₂), 6.52 (1H, b, NH), 6.78 (1H, s, Im 4), 7.31 (15H, m, Ar), 7.46 (1H, s, Im 2), m/z (F.D. 25 mA), 828 (MH⁺), 783, 766.

Histidyl-N^α-methylphenylalanylarginine. CIII.

The preceding fully protected tripeptide (200 mg, 0.24 mmol) was

dissolved in acetic acid (80% aq) and hydrogenolysed using 10% Pd/C (100 mg) during 24h. The solution was filtered through celite to remove catalyst, evaporated to a residue and re-dissolved in a little 20% acetic acid. This solution was chromatographed on a column of Sephadex G10 swollen and eluted with 5% acetic acid. Appropriate fractions, R_f (L2) 0.05, (K1) 0.60 were selected on the basis of their u.v. absorption and optical rotation profiles. These were pooled and evaporated to give the Boc-protected material (100 mg 75%). This material was treated with TFA (4 ml) at 0°C for 0.5h. Evaporation of the TFA and trituration with ether gave a pink material, which was dissolved in a minimum of 25% acetic acid and chromatographed on a column of Amberlite IRA 45 OH which had been previously equilibrated to its acetate form. Appropriate fractions were lyophilised, and the resulting solid was triturated with ether and dried in vacuo to give the title compound as a buff powder (140 mg, 71%). R_f (K1, cellulose) 0.40, m.p. 65-71°C, δ_H (D_6 DMSO) 1.40, 1.55 (4H, m, 2 x Arg CH₂), 1.81 (9H, bs, CH₃CO₂⁻), 2.37 (2H, b, Arg δ CH₂), 2.82 (2H, m, β CH₂), 2.92 (3H, s, NCH₃), 3.05 (2H, m, β CH₂), 3.85 (1H, q, α CH), 4.1 (no int., bs, α CH and HO), 4.21 (1H, t, α CH), 6.54 (1H, s, Im 4), 7.21 (5H, m, Ph), 7.54 (1H, s, Im 2), 8.0 (3H, v.b, NH), 9.1 (1H, v.b, OH). Found: C, 48.2; H, 7.2; N, 17.1%. m/z (F.D.) 473 (NH⁺).
 $C_{22}H_{32}N_8O_4 \cdot 3CH_3CO_2H \cdot 2.25 H_2O$ requires C, 48.5; H, 7.0; N, 16.2 %.

N ^{α} -t-Butoxycarbonylphenylalanylazinomethane.CIV.

N ^{α} -t-Butoxycarbonylphenylalanine (6.63 g, 25 mmol) and triethylamine (3.5 ml, 25 mmol) were dissolved in dry ether (50 ml). The solution was cooled to -5°C and ethyl chloroformate (2.4 ml, 25 mmol) was added. After 5 min. the solution was transferred by cannula to another flask, and the residue of triethylammonium chloride was washed

with a little ether and discarded. To the filtrate and washings was added a dry, alcohol-free ethereal solution of diazomethane (prepared from 22 g "Diazald" precursor) at 5°C. The solution was stirred during 20 h. at this temperature. Following removal of the solvent the residue was taken up in ethyl acetate and washed with a solution of sodium hydrogen carbonate and then water. Removal of the ethyl acetate gave a yellow oil. A small aliquot was purified by conventional silica chromatography on a pre-packed column, R_f (E3) 0.55. The fraction containing the purest material crystallised spontaneously, and was used to initiate crystallisation in the bulk sample. The resulting solid was separated from the mother-liquor and recrystallised from hexane to give the title compound as yellow needles (5.1 g, 70%), m.p. 97-9°C (lit. 69-70°C), $(\alpha)_D^{20} + 13.9^\circ$ ($c = 0.95$ CHCl₃), no lit. μ_{\max} (CHCl₃) 3415, 2110, 1710 (urethane), 1640 (keto), δ_{H} (CDCl₃); 1.42(9H, s, (CH₃)₃), 3.04(2H, d, β CH₂), 4.44 (1H, m, α CH), 5.13(1H, d, NH), 5.24(1H, bs, CH = N), 7.25 (5H, m, Ph), m/z (NH₃ BCI), 409 (28 % unknown), 290 (MH⁺ 100), 206 (30), Found: C, 62.6; H, 6.8; N, 14.8. Calc. for C₁₅H₁₉N₃O₃; C, 62.3; H, 6.6; N, 14.5%

N ^{α} -t-Butoxycarbonyl- β -homophenylalanine.CVI.

A small quantity of silver benzoate was prepared from benzoic acid and silver nitrate in accordance with the literature method.¹⁴¹

N ^{α} -t-Butoxycarbonylphenylalanylazinomethane (0.87 g, 3 mmol), was dissolved in "super-dry" methanol (4 ml) and a few drops of a solution¹⁴⁶ prepared from fresh silver benzoate (0.1 g) and triethylamine (1 ml) were added. Evolution of nitrogen began immediately, and the reaction was stirred at RT during 3h, A little activated charcoal was added, and the solution was filtered and evaporated to a residue which was taken up in

ethyl acetate (10 ml), washed several times with water, dried and evaporated to an oil. R_f (56) 0.65 (0.46g, 1.57 mmol; 52%). The methyl ester, CV, was dissolved in methanol (10 ml) and hydrolysed over a period of 4h, with sodium hydroxide solution (1M; 3 ml). The solution was adjusted to pH7 with dilute hydrochloric acid, reduced to a small volume and partitioned between ethyl acetate and saturated sodium hydrogen carbonate solution. The aqueous layer was separated, acidified to pH4 (HCl) and extracted into fresh ethyl acetate. This new organic layer was washed with water, dried and evaporated to a white residue which was recrystallised from hexane to give the required compound (0.32 g, 73%), m.p. 67-8°C, $(\alpha)_D^{20}$ -14.9° (c = 1.025, MeF), δ_H (CDCl₃), 1.60 (9H, s, (CH₃)₃), 2.65 (2H, m, α CH₂), 3.05 (2H, m, γ CH₂), 4.30 (1H, m, β CH), 5.30 (1H, b, NH), 7.35 (5H, m, Ph), 9.25 (1H, bs, OH), m/z 280 (MH⁺ 24%), 224 (79), 180 (100).

N ^{α} -t-Butoxycarbonyl- β -homophenylalanine-N-hydroxysuccinimide ester.CVII.

N ^{α} -t-Butoxycarbonyl- β -homophenylalanine (350 mg, 1.25 mmol) and N-hydroxysuccinimide (140 mg, 1.25 mmol) were dissolved in dioxan (3 ml), and a cooled solution of DCCl (260 mg, 1.25 mmol) in dioxan (2 ml) was added. The solution was stirred at 4°C for 12 h. The precipitated DCU was filtered off and washed with dioxan, and the combined solution and washings were evaporated to dryness. Addition of chloroform dissolved the bulk of the material; this solution was filtered, and upon addition of a little hexane the compound crystallised as needles. These were washed with ether and dried in vacuo to give the title compound (200 mg, 43%), m.p.

128-9°C, δ_H (CDCl₃), 1.42 (9H, s, (CH₃)₃), 2.27 (2H, d, CH₂), 2.80, 2.94 (2H, m, γ CH₂), 2.87 (4H, s, -COCH₂CH₂CO-), 3.74 (1H, d of d, β CH),

5.10 (1H, bd, NH), 7.29 (5H, m, Ph).

Histidyl- β -homophenylalanylarginine.CXI.

Having obtained the protected and activated amino-acid derivative described above, the synthesis from then on paralleled closely that of H HisPheArgOH already described. Hence it is presented in condensed form.

a). Coupling to H Arg(NO₂)OBzl (261.2 mg, 0.4 mmol)

This proceeded in good yield in dioxan. Following a conventional work up, t-butoxycarbonyl- β -homophenylalanyl-N^G-nitroarginine benzyl ester CVIII was obtained as a white solid. M.p. 154-6°C, (α)_D²⁰ -12.80° (c = 1.07, CHCl₃), δ_{H} (CDCl₃) 1.34 (9H, s, (CH₃)₃), 1.62 (4H, m, ArgCH₂) 1.88 (2H, m, ArgCH₂), 2.39 and 2.53 (2H, oct., γ CH₂) 2.82 (2H, m, α CH₂), 3.23 (1H, m, α CH), 3.43 (1H, bm, β CH), 4.14 (1H, b, NH), 4.66 (1H, b, NH), 5.17 (2H, s, OCH₂), 6.93 (1H, d, NH), 7.3 (10H, m, Ar), 7.73 (2H, b, guan. NH). (535.8 mg, 94%)

b). Coupling to Boc His (π Bom)OH. (0.2 mmol)

Deprotection of CVIII and coupling by the DCCI method proceeded in reasonable yield to give, after gel permeation chromatography on Sephadex LH20/THF, t-butoxycarbonyl-N ^{π} -benzyloxymethyl histidyl- β -homophenylalanyl-N^G-nitroarginine benzyl ester CIX. M.p. 65-70°C (non-crystalline) δ_{H} (CDCl₃), 1.40 (9H, s, (CH₃)₃), 1.56, 1.70, 1.85 (4H, m, Arg CH₂), 2.31 (2H, d, Arg δ CH₂), 2.68 (2H, m, α CH₂), 2.80 (2H, m, β CH₂ on His), 3.05 (4H, m, γ CH₂ and β CH), 4.53 (2H, s, CO₂CH₂-), 5.13 (2H, q, PhCH₂O), 5.38 (2H, s, NCH₂), 5.61 (1H, d, NH), 6.90 (1H, s, Im 5), 7.2 (15H, m, Ar), 7.74 (1H, s, Im 2), 7.91 (1H, bm, guan. NH). m/z (+ve Ar FAB). 828 (2%), 782 (3), 230 (2), 91 (100). (761 mg, 72%)

c). The fully protected tripeptide CIX was hydrogenolysed in 80% acetic

acid using 10% Pd on carbon as catalyst, and subsequently chromatographed on Sephadex G10 using 5% acetic acid as eluent. Pooling of appropriate fractions followed by evaporation gave t-butoxycarbonylhistidyl- β -homophenylalanylarginine CX. This was treated with trifluoroacetic acid to give the fully deprotected tripeptide as its trifluoroacetate. This material was chromatographed on an Amberlite ion-exchange column giving, after evaporation of appropriate fractions, the title compound Histidyl- β -homophenylalanylarginine CXI as its triacetate. M.p. 54-58° (v. hyg). R_f (X1, cellulose) 0.35 (Sak. and Pauli + ve). δ_H (D₂O) 1.47, 1.63 (4H, m, β and γ CH₂ on Arg), 1.78 (9H, s, CH₃CO₂⁻), 2.39 (2H, m, δ CH₂ Arg), 2.75 (4H, m, β CH₂ and α CH₂ on His), 3.00 (2H, t, γ CH₂), 3.90 (1H, m, β CH), 3.95 (1H, m, α CH), 4.03 (1H, d of d α CH), 4.32 (1H, b, NH), 7.05, 6.99 (1H, 2 X s, Im⁴ and Im⁺⁴), 7.13 (5H, m, Ar) 8.24, 8.38 (1H, 2X s, Im² and Im⁺²). Found C; 50.1, H; 7.2, N; 15.8, C₂₂H₃₂N₈O₄·3AcOH·1H₂O requires C; 50.2, H; 6.9, N; 16.7% (165 mg, 67%)

α -t-Butoxycarbonylcyclohexylalanine. CXII.

β -Cyclohexylalanine hydrochloride (2.08 g, 10 mmol), which had been prepared previously by exhaustive hydrogenation of phenylalanine, was dissolved in cooled sodium hydroxide solution (1M; 21 ml, 2 mmol). A solution of di-t-butyl dicarbonate (2.40 g, 11 mmol) in dioxan (30 ml) was added slowly, and the mixture was stirred at RT during 2h. Following evaporation of the solvents, the residue was taken up in ethyl acetate and washed with potassium hydrogen sulphate solution (2M) and water. Drying and evaporation of the organic layer gave the required product as an oil which could not be obtained as a solid, (2.37 g, 87%). R_f (R3) 0.65, (α) δ_D^{20} - 9.85° (c = 4.26, AcOH), δ_H (C₂Cl₂) 0.93 (2H, m, Cyclo (4)

CH₂), 1.23 (4H, m, Cyclo (3,5) CH₂), 1.47 (9H, s, (CH₃)₃), 1.68 (4H, m, Cyclo (2,6) CH₂), 1.31 (1H, d, Cyclo (1) CH), 4.34 (1H, q, α CH), 4.88 (1H, d, NH)

N^α-t-butoxycarbonyl-N^π-benzyloxymethylhistidylcyclohexylalanyl-N^G-nitroarginine benzyl ester.CXIV.

N^α-t-butoxycarbonylcyclohexylalanine was coupled to N^G-nitroarginine benzyl ester ditosylate by the HOBT/DCCI method (Et₃N; DMF; 15 mmol scale). Following a work-up involving successive washings with 100 ml portions of citric acid, saturated sodium hydrogen carbonate solution, and water, N^α-t-butoxycarbonylcyclohexylalanyl-N^G-nitroarginine benzyl ester CXIII was obtained. This material was sufficiently pure for use in the next step. (4.9 g, 60%), m.p. 78-80°C.

The above Boc-protected dipeptide (2.19 g, 4mmol), was dissolved in dichloromethane (5 ml) at 0°C, and treated with TFA (5 ml) for 0.5h. Evaporation of the solvent and trituration with ether gave the deprotected material which was taken up in DMF (5 ml) and adjusted to "pH" 9.5 with triethylamine. N^α-t-Butoxycarbonyl-N^π-benzyloxymethylhistidine (1.50 g, 4 mmol), HOBT (0.55 g, 4.1 mmol) and DCCI (0.83 g, 4.05 mmol) were dissolved in DMF (7 ml) and added to the above solution at 0°C. After 12h. the solution was filtered, and evaporated to a residue which was taken up in chloroform and washed with successive portions of citric acid solution, saturated sodium hydrogen carbonate and water. Evaporation of the solvent gave a solid which was trituated with ether and dried in vacuo to give the title compound CXIV as a buff powder (2.42 g, 74%), m.p. 144-7°C δ_H (CDCl₃) 0.87 (2H, m, Cyclo (4) CH₂), 1.16 (10H, b-m, Cyclo CH₂ and Arg CH₂), 1.93 (1H, m, Cyclo CH), 2.46 (2H, b,

NH), 3.10 and 3.33 (4H, m, 2 X β CH₂), 4.21 (1H, m, α CH), 4.45 (1H, m, α CH), 4.53 (1H, m, α CH), 4.61 (2H, s, Ph CH₂OCH₂), 5.17 (2H, q, CO₂CH₂-), 5.35 (2H, m, NCH₂), 5.57 (1H, d, NH), 6.82 (1H, s, Im 5), 7.34 (10H, m, Ar), 7.59 (1H, s, Im 2), 7.75 (1H, b, NH), 8.53 (1H, b, NH), m/z (F.D.) 820 (MH⁺) 776, 759.

Histidylcyclohexylalanylarginine.CXV.

The above fully protected tripeptide CXIV (1 mmol, 820 mg) was dissolved in 80% acetic acid (20 ml) and hydrogenolysed during 60h. The catalyst was then removed by filtration through celite, and the solution was evaporated to a residue which was taken up in dichloromethane (5 ml) and treated with TFA (5 ml) during 1h. The solution was evaporated and the residue was dissolved in a minimum of 5% acetic acid and chromatographed on a column of Sephadex G10, eluting with the same solvent. Appropriate fractions were pooled and lyophilised to give the title compound as a buff powder (110 mg, 42%) m.p. 120-130° (dec.).

$(\alpha)_D^{21} = -5.21^\circ$ (c = 0.49, H₂O), R_f(X1, cellulose) 0.25, $\delta_{\text{H}}^{\text{H}}(\text{D}_6\text{DMSO})$, 0.86 (2H, m, Cyclo CH₂), 1.12(4H, m, CycloCH₂), 1.49, 1.63, (1H, cyclo CH₂ and CH, Arg CH₂), 2.38 (small, s, trace of CH₃CO₂⁻), 3.08 (4H, m, β CH₂), 3.53(5H, v.b, NH), 4.05(1H, m, α CH), 4.17(1H, m, α CH), 4.33 (1H, q, α CH), 7.02(1H, s, Im4), 7.27(3H, v.b, guan NH), 7.66(1H, v.b. guan NH), 7.84(1H, s, Im2), 8.67(1H, d, NH), Found C; 40.9, H; 5.8, N; 15.1 C₂₁H₃₇N₈O₄.2CF₃CO₂H.2H₂O requires C; 41.2, H; 5.9, N; 15.4 %

D,L-H ^{α} -t-Butoxycarbonylphenylglycine.CXVI.

D,L-Phenylglycine (1.51 g, 10 mmol) was dissolved in sodium hydroxide solution (1M; 10 ml), and cooled over an ice bath. Di-t-butyl-dicarbonate (2.40 g, 11 mmol) was then added, and the solution was

allowed to stand for 12h. Following removal of the solvents, the residue was taken up in ethyl acetate and extracted into saturated sodium hydrogen carbonate solution. The acid was then liberated from its sodium salt by acidification (KHSO_4 , sat., to pH4) and extracted into ethyl acetate. Drying (MgSO_4) and evaporation of this solution gave an oil which crystallized upon standing to give the required compound, (2.5 g, 99%), m.p. $110-3^\circ\text{C}$, $\delta_{\text{H}}(\text{CDCl}_3)$, 1.21(9H, s, $(\text{CH}_3)_3$), 5.14(1H, d, α CH), 7.41(5H, m, Ph), 8.11(1H, d, NH), 9.78(1H, v.b. OH).

D,L,N ^{α} -t-Butoxycarbonylphenylglycyl-N^G-nitroarginine benzyl ester.CXVII.

N^G-nitroarginine benzyl ester ditosylate (3.26 g, 5 mmol) was dissolved in DMF (6 ml) and the "pH" was adjusted to between 9 and 9.5 with triethylamine, to give solution A. D,L-N ^{α} -t-butoxycarbonylphenylglycine (1.22 g, 5 mmol), HOBT (0.74 g, 5.5 mmol) and DCCI (1.04 g, 5.05 mmol) were dissolved in DMF (5 ml), and to this solution, cooled to 0°C , was added solution A. The reaction was stirred at R.T. during 12h. After removal of the solvent the residue was taken up in dichloromethane and washed successively with citric acid (1M) sat. sodium bicarbonate and water. Drying and evaporation of the solution gave a solid in which several materials were evident. Flash chromatography (hexane, ethyl acetate, 1:3) gave the mixture of diastereoisomers (0.88 g, 32%), as two closely running spots of apparently equal intensity R_f (as above) 0.10, 0.15. $\delta_{\text{H}}(\text{CDCl}_3, \text{mixture})$ 1.41(18H, bs, $2 \times (\text{CH}_3)_3$), 1.60(4H, m, $2 \times \gamma \text{CH}_2$), 1.72(2H, m, 1 of δCH_2 ?), 1.88(4H, m, $2 \times \beta \text{CH}_2$), 3.14(2H, m, 1 of δCH_2 ?), 3.30 and 3.46(2H, m, αCH), 4.62(4H, m, $2 \times \text{PhCH}_2$), 5.10(1H, d, 1 of Pgl αCH), 5.17(1H, d, 1 \times Pgl αCH), 5.66(2H, b, NH), 7.34(20H, m, Ar), 7.52(4H, vbm, guan. NH), 8.58(2H, b, guan. NH).

LDL,LLL-N^α-t-Butoxycarbonyl-N^π-benzyloxymethyl histidylphenylglycyl-N^G-nitroarginine benzyl ester.CXVIII.

The preceding pair of dipeptides (450 mg, 0.83 mmol), was dissolved in TFA (10 ml) and stirred at 0°C during 1h. Evaporation of the reagent and trituration with ether gave the deprotected material which was taken up in a little DMF (3 ml) and adjusted to "pH" 9 with triethylamine to give solution A. N^α-t-Butoxycarbonyl-N^π-benzyloxymethylhistidine (310 mg, 0.83 mmol), HOBt (115 mg, 0.85 mmol) and DCCl (175 mg, 0.85 mmol) were dissolved in DMF (3 ml), to which was added solution A, at 0°C. The reaction was stirred at RT during 2 days. The crystalline precipitate of DCU was removed by filtration and washed with a little DMF. The combined filtrate and washings were evaporated to a small volume and applied to a column of Sephadex LH20, swollen and eluted with DMF. Appropriate fractions were pooled and evaporated, and the residue was triturated with ether and dried in vacuo to give the title material as a yellow powder, (636 mg, 95%). m.p. 110-5°C, δ_H(CDCl₃), 1.40, 1.46(18H, 2 x s, (CH₃)₃), 1.53, 1.68, 1.99(12H, m, Arg CH₂'s), 3.06(4H, m, βCH₂), 4.43(4H, s, CO₂CH₂) 4.58(2H, m, αCH), 4.71(1H, m, αCH), 5.10(2H, m of d, Pgl αCH), 5.17(4H, m, PhCH₂O), 5.44(4H, m, NCH₂), 5.71(2H, bm; D₂O ex, NH), 6.78(1H, s, Im4), 6.86(1H, s, Im4), 7.28(30H, m, Ar), 7.58(1H, bs, 2 x Im2), m/z (+ve Ar FAB), 800(MH⁺, 100%), 754(50) 737(10).

LDL,LLL-Histidylphenylglycylarginine.CXX.

The preceding fully protected tripeptide (400 mg, 0.5 mmol) was dissolved in acetic acid (80%; 20 ml), and hydrogenolysed during 6h in the presence of 10% Pd on carbon (300 mg). The catalyst was removed by filtration through Celite, and following concentration of the solution

the residue was passed down a column of Sephadex G10, swollen and eluted with 5% acetic acid. Appropriate fractions were pooled and lyophilised, to give LDL, LLL-N^α-t-butoxycarbonylhistidylphenylglycyl-arginine, CXIX, as a white powder, (250 mg, 92%). δ_{H} (D₂O, mixture), 1.15 (18H, 2 X s, 2 X (CH₃)₃), 1.40 (4H, m, 2 X γ CH₂), 1.53 (2H, m, 2 X 1 of δ CH₂), 1.62 (4H, m, β CH₂), 1.78 (18H, s, CH₃CO₂⁻), 2.76 (2H, m, 2 X 1 of δ CH₂), 2.95 (4H, m, His β CH₂), 3.99 (2H, "q", 2 X α CH), 4.22 (2H, q, 2 X α CH), 5.27 (2H, bs, 2 X Pgl α CH), 6.97 (1H, s, Im4), 7.07 (1H, s, Im4), 7.13-7.23 (10H, m, Ph), 8.26 (1H, s, Im2), 8.39 (1H, s, Im2), m/z (+ve Ar FAB) 545 (MH⁺). This Boc-protected tripeptide (182 mg, 0.3 mmol), was treated as before with trifluoroacetic acid and then purified by chromatography on an Amberlite IRA 45 OAc column. The material was freeze dried twice to give the title compound, CXIX (129 mg, 76%). R_{f} (x1, cellulose); 0.80 (diastereoisomers not resolved) m.p. 164-8^oC, δ_{H} (D₆ DMSO), 1.31 (2H, m, Arg CH₂), 1.54 (4H, m, Arg CH₂), 1.67, 1.76 (2 X 2H, m, Arg β CH₂), 2.37 (2H, q - s with D₂O, δ CH₂), 3.11, 3.19 (4H, m, His β CH₂), 4.14 (1H, m, α CH), 4.27 (2H, m, α CH), 4.37 (1H, t, α CH), 5.54 (1H, d, Pgl α CH), 5.67 (1H, d, Pgl α CH), 7.32 (12H, m, 2 X Im4 and Ar), 7.68 (2H, b, guan NH), 7.76 (1H, t, NH), 7.89 (1H, t, NH), 8.48 (4H, vb, guan NH), 8.76 (1H, d, NH), 8.82 (1H, s, Im2), 8.87 (1H, d, NH), 8.90 (1H, s, Im2), 9.08 (1H, d, NH), 9.27 (1H, d, NH), all NH's exchanged by D₂O, m/z (+ve Ar FAB) 445 (MH⁺ 52%), 110 (100).

Urocanylphenylalanyl-N^G-nitroarginine benzyl ester. CXXI.

Urocanic acid, (4-imidazoleacrylic acid; 138 mg, 1 mmol), HOBT (135 mg, 1 mmol) and DCCI (206 mg, 1 mmol) were dissolved in DMF (3 ml) and cooled over an ice bath. To this solution was added H Phe Arg (NO₂)

OBzl (1 mmol) in DMF (2 ml), adjusted to pH 9-9.5 with triethylamine. This had been previously prepared from XCVI in the usual manner. The reaction was allowed to proceed at RT during 40h., the precipitated DCU was removed by filtration and the solution was evaporated to a small volume. This material was passed down a column of Sephadex LH20, swollen and eluted with DMF. Appropriate fractions were pooled and evaporated. The residue was triturated with ether, the ether was decanted and the residue was dissolved in methanol, filtered and evaporated to give the title compound as an amorphous solid, (468 mg, 80%). R_f (X1, cellulose) 0.7-0.9, m.p. 80-85°, δ_{H} (D_3COD), 1.63, 1.76, 1.92(6H, 3X m, Arg CH_2), 3.03(2H, oct, β CH_2), 4.50(1H, q, α CH), 4.74(1H, q, α CH_2), 5.15(2H, s, OCH_2), 6.50(1H, d; J = 15 Hz, CH =), 7.31(10/11H?, m, Ar + Im4?), 7.45(1H, d; J = 15 Hz, CH =), 7.74(1H, s, Im2), m/z (+ve Ar FAB) 663, 600, 577 (MH^+). Found C, 55.8; H, 6.0; N, 19.4. $\text{C}_{28}\text{H}_{32}\text{N}_8\text{O}_6$. MeOH requires C, 57.2; H, 5.9; N, 18.4%. (Urocanic acid, δ_{H} (D_2O) 6.40, 6.70 (d), 7.50, 7.75 (d), 7.95 (s, Im2 + Im4), 9.00 (s, OH).).

des-Amino-histidylphenylalanylarginine.CXXII.

The above protected compound CXXI, (108 mg, 1.8 mmol) was dissolved in acetic acid (80%; 10 ml) and hydrogenolysed/hydrogenated in a stream of hydrogen gas, in the presence of 10% Pd on carbon (100 mg) during 10h. The catalyst was removed by filtration, the filtrate was reduced to a small volume and chromatographed on a column of Sephadex G10, eluting with 5% acetic acid. Appropriate fractions were pooled and lyophilised to give the title compound as its diacetate (56 mg 48%).

R_f (X1) 0.70, $(\alpha)_{\text{D}}^{20} + 5.92^\circ$ (c = 0.355, acetic acid), δ_{H} (D_2O) 1.37, 1.53, 1.64(6H, 3X m, Arg CH_2), 1.74(6H, s, CH_3CO_2^-), 2.41, 2.71(4H,

2 X m, 1mCH₂CH₂CO), 3.00(2H, t, β CH₂ Phe) 3.99(1H, q, α CH), 4.43 (1H, m, α CH), 6.74(1H, s, Im4), 7.10(5H, m, Ph), 8.27(1H, s, Im2)
 m/z (+ve Ar FAB) 443 (MH⁺). Found C, 48.2; H, 6.7; N, 17.1.
 C₂₁H₂₉N₇O₄ · 2AcOH · 3H₂O requires C, 48.6; H, 7.0; N, 15.9%.

Attempted preparation of a protected β-homohistidine.

N^α-Benzyloxycarbonyl-N^π-t-butoxymethylhistidine NI (100 mg, 0.27 mmol) was suspended in dry dichloromethane (4 ml) and was dissolved on addition of triethylamine (38 μl, 0.27 mmol). Redistilled ethyl chloroformate (26 μl, 0.27 mmol) was then added slowly over 1 min., maintaining the temperature at -5 °C with an ice/salt bath. The triethylamine hydrochloride produced remained in solution, and could not therefore be filtered off as desired. Excess ethereal diazomethane solution (1.4 mmol), free from alcohols and water, was then added until the solution remained bright yellow. The reaction mixture was left stirring overnight, under nitrogen. The solution was then washed with sodium hydrogen carbonate solution, and water, dried and evaporated to a yellow oil. Examination by TLC (E4) showed one major spot R_f 0.8 and several minor ones. Flash chromatography (E6) gave 30 mg of this material, which could not be identified with certainty. m/z 438 (2%) and 404 (44%) indicated it might well be N^α-benzyloxycarbonyl-N^π-t-butoxymethylhistidine methoxymethyl ketone (m.w. 403) perhaps derived from the chloromethyl ketone. I.r. 3440, 2980, 1725, 1185 indicated none of the expected azinomethane was present.

N^α-Phthaloyl-N^π-benzyloxymethylhistidine (405 mg, 1 mmol) was dissolved in freshly dried dichloromethane, under nitrogen. Ethyl chloroformate (150 μl, 1.05 mmol) was added slowly, followed by

triethylamine (140 μ l, 1.00 mmol). The mixture was allowed to stand for a few minutes, and then a solution of diazomethane in dry ether was added to excess. The reaction was allowed to stand at RT during 12h. Triethylammonium chloride was removed by filtration; evaporation of the solvent gave a yellow oil. T.l.c. examination of this material showed numerous compounds to be present. Chromatography in 10% methanol in ether (3 principle spots, R_f 's 0.67, 0.56, 0.23), performed using a Chromatotron, showed that the only significant material was that of R_f 0.67, an oil which appeared to be N^α -phthaloyl- N^π -benzyloxymethyl-histidine ethyl ester XXIII, I.r. 1730 cm^{-1} δ_H (CDCl_3) 1.20(3H, t, CH_3), 3.59(2H, m, βCH_2), 4.20(2H, q of d, CH_2CH_3), 4.45(2H, d of d, 7.5 H_2 , Ph CH_2), 5.17(1H, q, αCH), 5.30(2H, q, N CH_2), 6.71(1H, s, Im4), 7.30(5H, m, Ar), 7.40(1H, s, Im2), 7.72(4H, d of m, Pth), m/z (EI) 434 (MH^+ , 57), 404 (58), 314 (18) 91 (100).

1. Pfizer- An Informal History. S. Mines, (1978).
2. C.R. Beddell, Chem. Soc. Rev., (1984), 13 (3), 279-319.
3. D.W. Cushman and M.A. Ondetti, Prog. Med. Chem., (1980), 17, 41-104.
4. Ibid. refs., 41-6.
5. D. Hodgkin, personal communication, Oxford, (1984).
6. M.A. Ondetti, B. Rubin and D.W. Cushman, Science, (1977), 196, 441.
7. C.H. Hassall, Computer graphics as an aid to drug design, Chem. Br., Jan 1985, 39-46.
8. G.J. Moore and J.M. Matsoukas, The Peptides (1984), 615-9, (Ed. U. Ragnarsson. Almqvist and Wiksell, Stockholm Swed.).
9. R.G. Almquist, w.-R. Chao and C. Jennings-White, J. Med. Chem., (1985), 28, 1067-71.
10. R.F. Meyer, E.D. Nicolaides, E.D. Tinney, F.J. Lunney, E.A. Holmes, H.L. Hoefle, R.D. Smith, A.D. Essenburgh, H.R. Kaplan, and R.G. Almquist, J. Med. Chem., (1981), 24, 964-9.
11. A.B. Atkinson and J.J.S. Robertson, Lancet, (1979), 2, 836.
12. D.W. Cushman, H.-S. Cheung, E.F. Sabo and M.A. Ondetti, Biochemistry, (1977), 16 (25), 5484-9.
13. C.H. Hassall, A. Krohn, C.J. Moody and W.A. Thomas, J. Chem. Soc. Perkin Trans. 1, (1984), 155-64.
14. M.R. Attwood, C.H. Hassall, A Kröhn, G. Lawton and S. Redshaw, J. Chem. Soc. Perkin Trans. 1, (1983), 1011-9.
15. F.J. McEvoy, F.M. Lai and J.D. Albright, J. Med. Chem., (1983), 26, 381-94.
16. A.A. Patchett, E. Harris, E.W. Tristram, M.J. Wyvratt, H.T. Wu,

- (16) D. Taub, E.R. Peterson, T.J. Ikeler, E.D. Thorsett, W.J. Greenlee, N.S. Lohr, R.D. Hoffsommer, H. Joshua, J. Ten-Broeke, L.G. Payne, D.L. Ondeyka, W.V. Ruyle, T.W. Rothrock, S.D. Aster, A.L. Maycock, F.M. Robinson, R. Hirschmann, C.S. Sweet, E.H. Ulm, D.M. Gross, T.C. Vassil, and C.A. Stone, Nature (London), (1980), 288 (5788), 280-3.
17. D.H. Kim, C.J. Guinosso, G.C. Buzby, D.R. Herbst, R.J. McCaully, T.C. Wicks and R.L. Wendt, J. Med. Chem., (1983), 26, 394-403.
18. M. Bodanszky, Principles of Peptide Synthesis, Springer-Verlag, (Berlin), (1984).
19. J.H. Jones, Peptides, (New York), (1979), 1, 65-104.
20. I. Galpin, Chem. Br., (1978), 14, 181-6, 193.
21. Specialist Periodical Reports, 1-18, The Royal Society of Chemistry, (London).
22. e.g. See, concerning hydrophobicity data; E.Q. Lawson, A.J. Sadler, D. Harmatz, D.T. Brandau, R Micanovic, R.D. MacElroy and C.R. Middaugh, J. Biol. Chem., (1984), 259 (5), 2910-2.
23. J.H. Jones and T. Brown, (1982), U.K. Pat. No.2,099,816 B.
24. J.C. Sheehan, K. Hasspacher and Y.L. Yeh, J. Am. Chem. Soc., (1959), 81, 6086.
25. H. Rink and B. Riniker, Helv. Chim. Acta, (1974), 57, 831-5.
26. F. Schneider, Z. Physiol. Chem., (1960), 320, 82-91.
27. R.H. Mazur and J.M. Schlatter, J. Org. Chem., (1963), 28, 1025-9.
28. T. Baba, H. Sugiyama and S. Seto, Chem. Pharm. Bull., (1973), 21 (1), 207-9.
29. H. Yajima, S. Futaki, N. Fujii, K. Akaji, S. Funakoshi, H. Sakurai, S. Katakura, K. Inoue, R. Hosotani, T. Tobe,

- (29) T. Segawa, A. Inoue, K. Tatemoto and V. Mutt, J. Chem. Soc. Chem. Commun., (1985), 877-8.
30. R. Geiger and W. Köenig, Peptides, (New-York), (1981), 3, 1-99.
31. V. du Vigneaud and O.K. Behrens, J. Biol. Chem., (1937), 117, 27-36.
32. G.C. Stelakatos, D.M. Theodoropoulos and L. Zervas, J. Am. Chem. Soc., (1959), 81, 2884-7.
33. S. Shaltiel, Biochem. Biophys. Res. Commun., (1967), 29 (2), 178-83.
34. G. Jager, R. Geiger and W. Siedel, Chem. Ber., (1968), 101, 3537-44.
35. S. Sakakibara and T. Fujii, Bull. Chem. Soc. Jpn., (1969), 42 (5), 1466.
36. A.R. Fletcher, J.H. Jones, W.I. Ramage and A.V. Stachulski, J. Chem. Soc. Perkin Trans. 1, (1979), 2261-7.
37. F. Weygand, W. Steglich and P. Pietta, Chem. Ber., (1967), 100 (3), 3841-9.
38. P.B. Wyatt, D. Phil. thesis, Oxford, (1987).
39. L. Birkhofer, P. Richter and A. Ritter, Chem. Ber., (1960), 93, 2804-9.
40. R. Ramage and O. Ogunjobi, Personal Communication, Edinburgh, (1986).
41. T. Brown, J.H. Jones and J.D. Richards, J. Chem. Soc. Perkin Trans. 1, (1982), 1533-61.
42. G.M. Bonora, C. Toniolo, J.H. Jones and K.N. Rajasekharan. Int. J. Peptide Protein Res., (1986), 27, 1-6.
43. H. Szelke, B. Leckie, A. Hallett, D.M. Jones, J. Sueiras, B. Atrash and A.F. Lever, Nature (London), (1982), 299, 555-7.

44. J.M. Bernard, H. Gras-Masse, H. Drobecq, A. Tartar, P. Lefrancier, A. Hosmalin, C. Carelli and L. Chedid, Int. J. Peptide Protein Res., (1987), 29, 455-63.
45. F. Colombo, R. Colombo and J.H. Jones, J. Chem. Soc. Chem. Commun., (1984), 292-3.
46. Our Milan collaborators, F. Colombo, R. Colombo and F. Fontana prepared and purified a number of compounds with this author's assistance, within this laboratory. It had been intended that the work be submitted for publication in J. Chem. Soc. Perkin Trans. 1, but this has not proved possible because contact with Dr Robert Colombo has been lost. Details of these compounds, being inextricably bound-up with the remainder of the present work and not due to be published elsewhere, are included in the appropriate experimental chapter.
47. H.W. Pinnick and N.H. Lajis, J. Org. Chem., (1978), 43, 3964-6.
48. T. Benneche, P. Strande, and K. Undheim, Synthesis, (1983), 762-3.
49. P.M. Pojer and S.J. Angyal, Aust. J. Chem., (1978), 31, 1031-40.
50. T.G. Levi, Gazz. Chim. Ital., (1932), 62, 775-80, Chem. Abs. (1933), 27, 268.
51. E.J. Corey and M.G. Bock, Tetrahedron Lett., (1975), 3269-70.
52. J.H. Jones, D.W. Thomas, R.M. Thomas and M.E. Wood, Synth. Commun., (1986), 16 (13), 1607-10.
53. D.L. Rathbone, Part II thesis, Oxford (1984).
54. R.G. Webb, M.W. Haskell and C.H. Stammer, J. Org. Chem., (1969), 34 (3), 576-80.
55. D. Clipston, Part II thesis, Oxford, (1981).
56. Separate work in this laboratory, using the method of

- (56) D.S. Connor, C.W. Klein and C.N. Taylor, Org. Synth., (1972), 52, 16.
57. J.K. Kochi, J. Org. Chem., (1965), 30, 3265-71.
58. N.I. Jones, Part II thesis, Oxford (1984).
59. C.J. Chivikas and J.C. Hodges, J. Org. Chem., (1987), 52, 3591-4.
60. M.K. Ellis, B.T. Golding and W.P. Watson, J. Chem. Soc. Perkin Trans. II, (1984), 1737-43.
61. IUPAC-IUB Joint Commission on Biochemical Nomenclature, Nomenclature and Symbolism for Amino Acids and Peptides, Eur. J. Biochem., (1984), 138, 9.
62. D.F. Veber, In "Peptides, Chemistry, Structure and biology", Proceedings of the 4th American Peptide Symposium, (Eds; R. Walter and J. Meienhofer. Ann Arbor. Sci. Pub. : Ann Arbor, MI 307-16).
63. J.H. Jones, W.I. Ramage and M.J. Witty, Int. J. Peptide Protein Res., (1980), 15, 301-3.
64. J. Kovacs, S Kim, E. Holleran and P. Gorycki, J. Org. Chem., (1985), 50, 1497-504.
65. J.B. Campbell, J. Chem. Soc. Perkin Trans. 1, (1983), 1213.
See also ref. 60.
66. C.J. Calleman and V. Poirier, Acta Chem. Scand. Ser. B., (1983), 37, 809.
67. D. Yamashiro, J. Blake and C.H. Li, J. Am. Chem. Soc., (1972), 94 (8), 2855-9.
68. E. Babad and D. Ben-Ishai, J. Heterocyclic Chem., (1969), 6, 235-7.
69. E. Bamberger and B. Berl e, Justus Liebig's Ann. Chem. (1893),

- (69) 273, 342.
70. H.R. Matthews and H. Rapoport, J. Am. Chem. Soc., (1973), 95, 2297.
71. T. Brown, J.H. Jones and J.D. Wallis, J. Chem. Soc. Perkin Trans. 1, (1982), 3045-8.
72. A number of other subsidiary compounds were examined which have no direct bearing on this work, for example Z Hisol (τ Trt) and Z Hisol (τ Bzl). See ref. 53.
73. Dr. N.L. Allan, I.C.I. New Science Group, kindly performed an M.N.D.O. calculation on compound XL and was able to demonstrate the torsion angle (C (α)-C (β)-C (Im)-C (Im)) could be easily optimised to two local minima; -12.9° (-89.8 Kcal), $+80.8^\circ$ (-95.9 Kcal).
74. E.J. Corey, J-L. Gras and P. Ulrich, Tetrahedron Lett., (1976), 11, 809-12.
75. L.A. Carpino and J.-H. Tsao, J. Chem. Soc. Chem. Commun., (1978), 358.
76. D.G. Mullen and G. Barany, Tetrahedron Lett., (1987), 28, 491-4.
77. R. Ramage, C.A. Barron, S. Bielecki and D.W. Thomas, Tetrahedron Lett., (1987), 28 (35), 4105-8.
78. J.C. Hodges, Synthesis, (1987), 20-4.
79. J.H. Jones, A.E. Derome, D.L. Rathbone, D.W. Thomas, R. Colombo, F. Colombo, F. Fontana, Proc. Amer. Peptide Symp. 9th, (1985), (Eds. V.J. Hruby, C.M. Deber and K.D. Kopple), Pierce Chemical Co.
80. R. Colombo, F. Colombo, A.E. Derome, J.H. Jones, D.L. Rathbone and D.W. Thomas, J. Chem. Soc. Perkin Trans. 1, (1985), 1811-5.
81. L. Michaelis and M. Mizutani, Z. Physik. Chem., (1925), 116, 135.

82. W. König and R. Geiger. In "Hypothalamic Hormones-Structure, Synthesis and Biological Activity", (Eds. D. Gupta and W. Voelter), (1975), 99-106. Verlag Chemie, Weinheim.
83. I. Photaki and A. Yiotakis, J. Chem. Soc. Perkin Trans. 1, (1976), 259-64.
84. L. Zervas and M. Bergmann, Ber., (1928), 61, 1195.
85. A.E. Miller and J.J. Bischoff, Synthesis, (1986), 777-9.
86. M. Bodanszky, C.A. Birkhimer, S. Lande, M.A. Ondetti, J.J. Sheehan and N.J. Williams, Peptides, Proc. European Sump. 6th, Athens, (1963), 3-10, (Pub. 1966).
87. D.W. Thomas, Part II thesis, Oxford, (1983).
88. E. Gazis, B. Bezas, G.C. Stelakatos and L. Zervas In Peptides 1962 (Ed. G.T. Young,) (1963), 17-21, Pergamon, Oxford.
89. S. Guttman and J. Pless, Acta Chim. Acad. Sci. Hung., (1965), 44, 23-30.
90. Z. Procházka, K. Jošt and K. Bláha, Chem. Listy, (1981), 75, 699-722.
91. M. Bodanszky and J.T. Sheehan, Chem. and Industry, (1960), 1268-9.
92. A. Turán, A. Patthy and S. Bajusz, Acta Chim. Acad. Sci. Hung., (1975), 85, 327-32.
93. E.E. Schallenberg and M. Calvin, J. Am. Chem. Soc., (1955), 77, 2779-83.
94. L. Zervas, M. Winitz and J.P. Greenstein, J. Org. Chem., (1957), 22, 1512-21.
95. L. Zervas, T.T. Otani, M. Winitz and J.P. Greenstein, J. Am. Chem. Soc., (1959), 81, 2878-84.
96. F.C. Grønvald, N.L. Johansen and B.F. Lundt, Peptides (1980). Proc. 16th Eur. Peptide Symp., Denmark, (Ed. K. Brunfeldt).

97. R. Colombo, Int. J. Peptide Protein Res., (1982), 19, 71.
98. H. Rink, P. Sieber and F. Raschdorf, Tetrahedron Lett., (1984), 25,(6), 621-4.
99. G. Losse and C. Rüger, Z. Chem., (1973), 13, 344-5.
100. H.B. Milne and C.H. Peng, J. Am. Chem. Soc., (1957), 79, 639-44.
101. R. Ramage and J. Green, Tetrahedron Lett., (1987), 28 (20), 2287-90.
102. C.W. Smith, G. Skala and J.R. Boal, J. Chem. Soc. Chem. Commun., (1981), 1243-4.
103. T.F. Spande, B. Witkop, Y. Degani and A. Patchornik, Adv. in Protein Chem., (1970), 24, 97-260.
104. L. Patthy and E.L. Smith, J. Biol. Chem., (1975), 250 (2), 557-69.
105. K. Morihara, T. Oka, H. Tsuzaki, K. Inouye and S. Sakakibara, In Peptides, Structure and Biological Function, (1979), 617-20, (Ed. E. Gross and J. Meienhofer), Pierce Chem. Co., Rockford. Illinois.
106. M. Sekine, J-I. Matsuzaki and T. Hata, Tetrahedron Lett., (1982), 23 (50), 5287-90.
107. V. Voorhees and G.S. Skinner, J. Am. Chem. Soc., (1925), 47, 1125.
108. W.R. Boon, J. Chem. Soc., (1957), 2146-58.
109. The Sakaguchi reagent as prepared by R. Acher and C. Crocker, Biochim. Biophys. Acta, (1952), 9, 704 was found to be satisfactory.
110. Y. Kondo and B. Witkop, J. Am. Chem. Soc., (1968), 90 (3), 764-7.
111. V. Grakauskas and A.M. Guest, J. Org. Chem., (1978), 43 (18), 3485-6.

112. P. de Meester, M.V. Jovanovic, S.S.C. Chu, and E.R. Biehl, J. Heterocyclic Chem., (1986), 23, 337-41.
113. H. Kappeler, Helv. Chim. Acta, (1961), 44 (59), 476-91.
114. Dept. of Medicinal Chemistry, Pfizer Central Research, Sandwich, Kent CT13 9NJ.
115. D.W. Cushman and H-S. Cheung, Biochem. Pharmacol., (1971), 20, 1637-48.
116. H-S. Cheung, F-L. Wang, M.A. Ondetti, E.F. Sabo, D.W. Cushman, J. Biol. Chem., (1980), 255 (2), 401-7.
117. G. Oshima, A. Gecse and E.G. Erdos, Biochim. Biophys. Acta, (1974), 350 (1), 26-37.
118. N.L. Benoiton and J.R. Coggins, Prog. Pept. Res., (Proc. Am. Pept. Symp.), 2nd, (1970), (Pub. 1972), 145-50, (Ed. S. Lande), New York.
119. B. Penke, J. Czobbas, L. Balásperi, J. Petres and K. Kovacs, Helv. Chim. Acta, (1970), 53, 1057-61.
120. K. Plucińska and B. Liberek, Tetrahedron, (1987), 43 (15), 3509-17.
121. M.A. Ondetti and S.L. Engel, J. Med. Chem., (1975), 18 (7), 761-3.
122. M.C. Khosla, R.A. Leese, W.L. Maloy, A.T. Ferreira, R.R. Smeby and F.M. Bumpus, J. Med. Chem., (1972), 15 (18), 792-5.
- (It may also be prepared by exhaustive hydrogenation of tyrosine.)
123. E. Waser and E. Brauchli, Helv. Chim. Acta, (1924), 7, 740-58.
124. H₂/ 10% Pd on C/ 10 days. e.g. see D.J. Schafer, G.T. Young, D.F. Elliott and R. Wade, J. Chem. Soc. (C), (1971), 46-9.
125. Chisso Corp. 27.06.80, JP 087564. Jap. Patent No. 57,014,556-A.
126. J. Kenny, N. Gee, R. Matsas, J. Stewart, H. Bowes and

126. A. Turner, Prog. Clin. Biol. Res., (1985), 180 (Intracell. Protein Catabolism), 175-84.
127. L. Horner and P. Kaiser, Ann., (1959), 626, 19-25.
128. G. Losse and U. Krychowski, J. Prakt. Chem., (1970), 312 (6), 1097-104.
129. W.I. Ramage, D. Phil. thesis, Oxford, (1978).
130. J.D. Richards, D. Phil. thesis, Oxford, (1981).
131. C.E. Braun, J. Am. Chem. Soc., (1933), 55, 1280-4.
132. V. Tolman, Collect. Czech. Chem. Commun., (1977), 42, 2537-9.
133. R.A. Boissonas, S. Guttman, R.L. Huguenin, P-A. Jaquenoud and E. Sandrin, Helv. Chim. Acta, (1958), 41 (2), 1867-82.
134. Dictionary of Organic Compounds, (Ed. J.B. Thomson, Eyre and Spottiswoode, London), 10th Supplement, 297.
135. N.-G. P.-H. Büu-Hoi and P. Desmerseman, J. Org. Chem., (1953), 18, 649.
136. F. Straus and R. Kühnel, Ber., (1933), 66, 1834-46.
137. M. Bergmann, L. Zervas and H. Rinke, Hoppe Seyler's Z. Physiol. Chem., (1934), 224, 40-4.
138. S. Sakakibara and N. Inukai, Bull. Chem. Soc. Jpn., (1966), 39, 1567.
139. L. Moroder, A. Hallett, E. Wünsch, O. Keller, and G. Wersin, Hoppe-Seyler's Z. Physiol. Chem., (1976), 357, 1651-3.
140. J.R. Coggins and N.L. Benoiton, Can. J. Chem., (1971), 49 (11), 1968-71.
141. J. Wilson, Org. React., (1957), 9, 332.

142. Prepared according to the method of G. Jager, R. Geiger and W. Siedel, Chem. Ber. (1968), 101, 3537.
143. C.A. reg N^o 6914-71-2. S. Danishefsky and R.K. Singh. J. Amer. Chem. Soc. (1975), 97, 3239.
144. See ref 134. D 07759 p. 2297.
145. P.M.G. Bavin, Anal. Chem (1960) 32 554.
146. A.J. Gordon and R.A. Ford. A Chemists Companion (Wiley, N.Y). p. 434.
147. B. Bak, C. Dambmann, F. Nicolaisen, E.J. Pedersen, N.S. Bhacca. J. Mol. Spectroscop., (1968), 26(1), 78-97.